



US 20160022224A1

(19) **United States**
(12) **Patent Application Publication**
Banet et al.

(10) **Pub. No.: US 2016/0022224 A1**
(43) **Pub. Date: Jan. 28, 2016**

(54) **SYSTEM FOR MEASURING VITAL SIGNS USING BILATERAL PULSE TRANSIT TIME**

A61B 5/04 (2006.01)
A61B 5/021 (2006.01)

(71) Applicant: **SOTERA WIRELESS, INC.**, San Diego, CA (US)

(52) **U.S. Cl.**
CPC *A61B 5/7278* (2013.01); *A61B 5/04* (2013.01); *A61B 5/6826* (2013.01); *A61B 5/02125* (2013.01); *A61B 5/02416* (2013.01); *A61B 5/0245* (2013.01); *A61B 5/742* (2013.01); *A61B 5/0004* (2013.01); *A61B 2562/16* (2013.01)

(72) Inventors: **Matthew John Banet**, San Diego, CA (US); **Michael James Thompson**, San Diego, CA (US); **Zhou Zhou**, La Jolla, CA (US); **Henk Visser, II**, San Diego, CA (US); **Robert Kenneth Hunt**, Vista, CA (US)

(21) Appl. No.: **14/875,487**

(22) Filed: **Oct. 5, 2015**

Related U.S. Application Data

(62) Division of application No. 11/420,652, filed on May 26, 2006, now Pat. No. 9,149,192.

Publication Classification

(51) **Int. Cl.**
A61B 5/00 (2006.01)
A61B 5/0245 (2006.01)
A61B 5/024 (2006.01)

(57) **ABSTRACT**
The invention provides a monitor for measuring blood pressure and other vital signs from a patient without using a cuff. The invention provides a hand-held device for measuring vital signs (e.g. blood pressure) from a patient that features: i) a housing that encloses a first sensor, that includes a first electrode and a first optical system configured to generate a first optical signal; ii) a second sensor that includes a second electrode and a second optical system configured to generate a second optical signal; iii) an amplifier system, in electrical contact with the first and second electrodes, configured to process electrical signals from the first and second electrodes to generate an electrical waveform; and iv) a microprocessor, in electrical communication with the amplifier system, first optical system, and second optical system, the microprocessor configured to process the electrical waveform and first and second optical signals with an algorithm to determine at least one of the patient's vital signs.

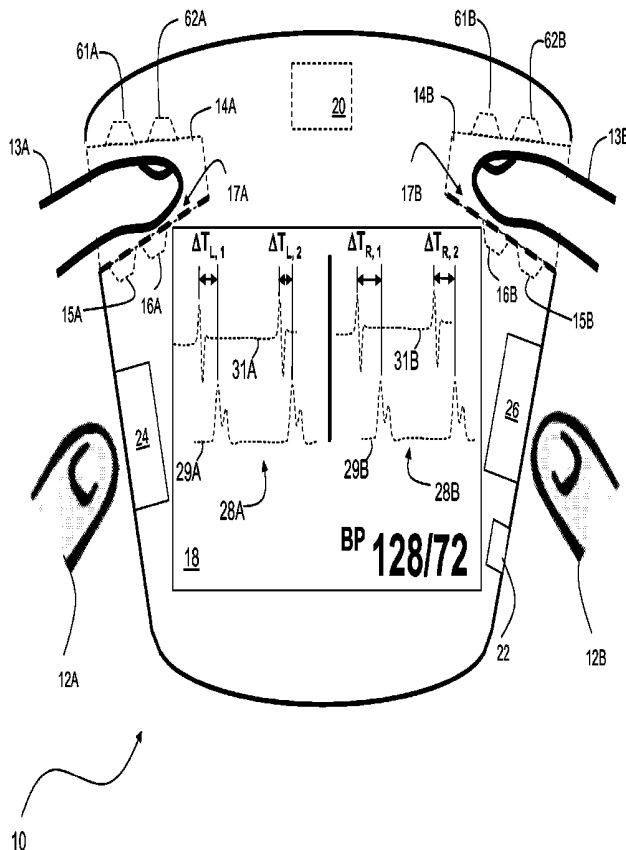

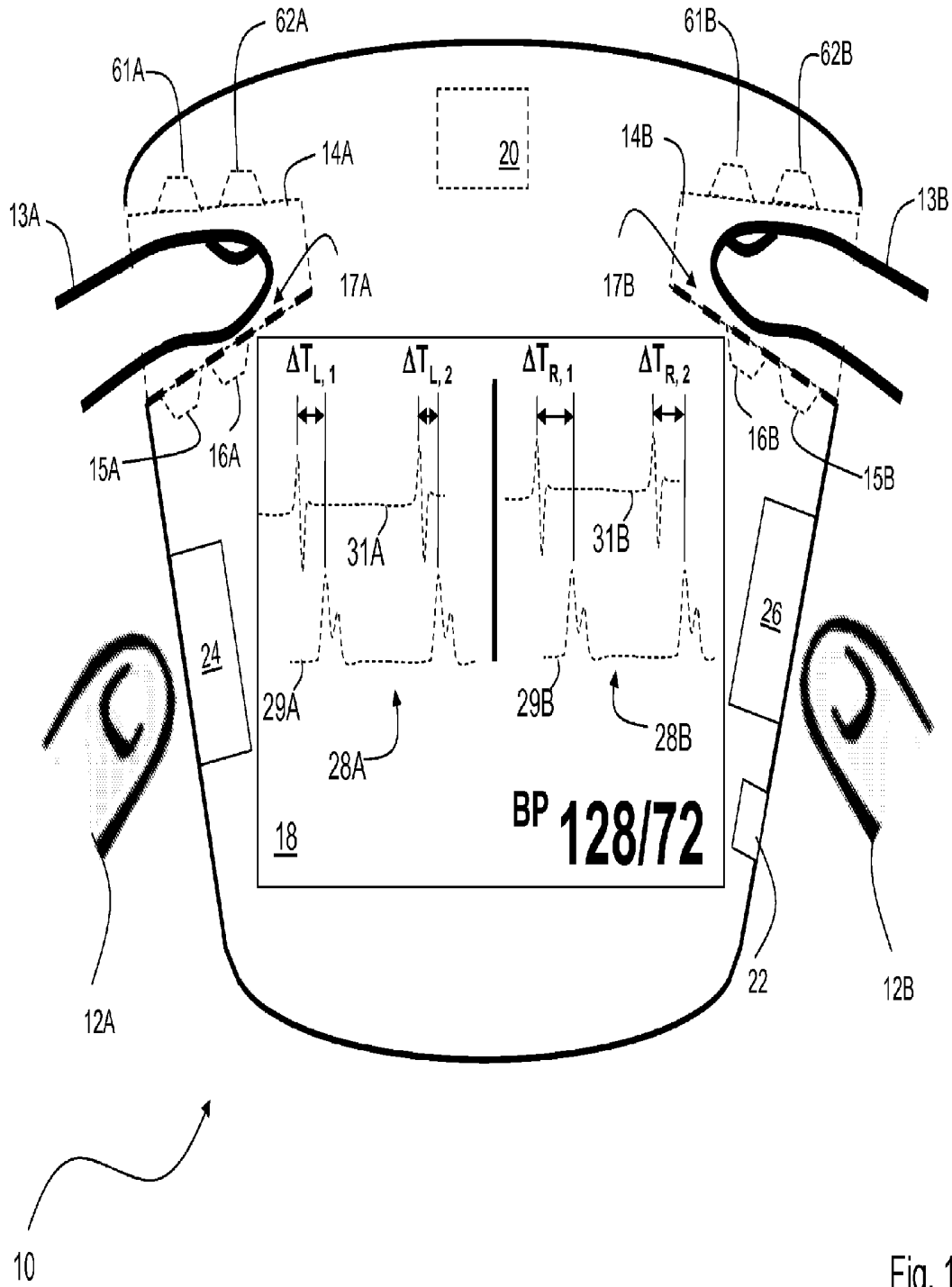

Fig. 1

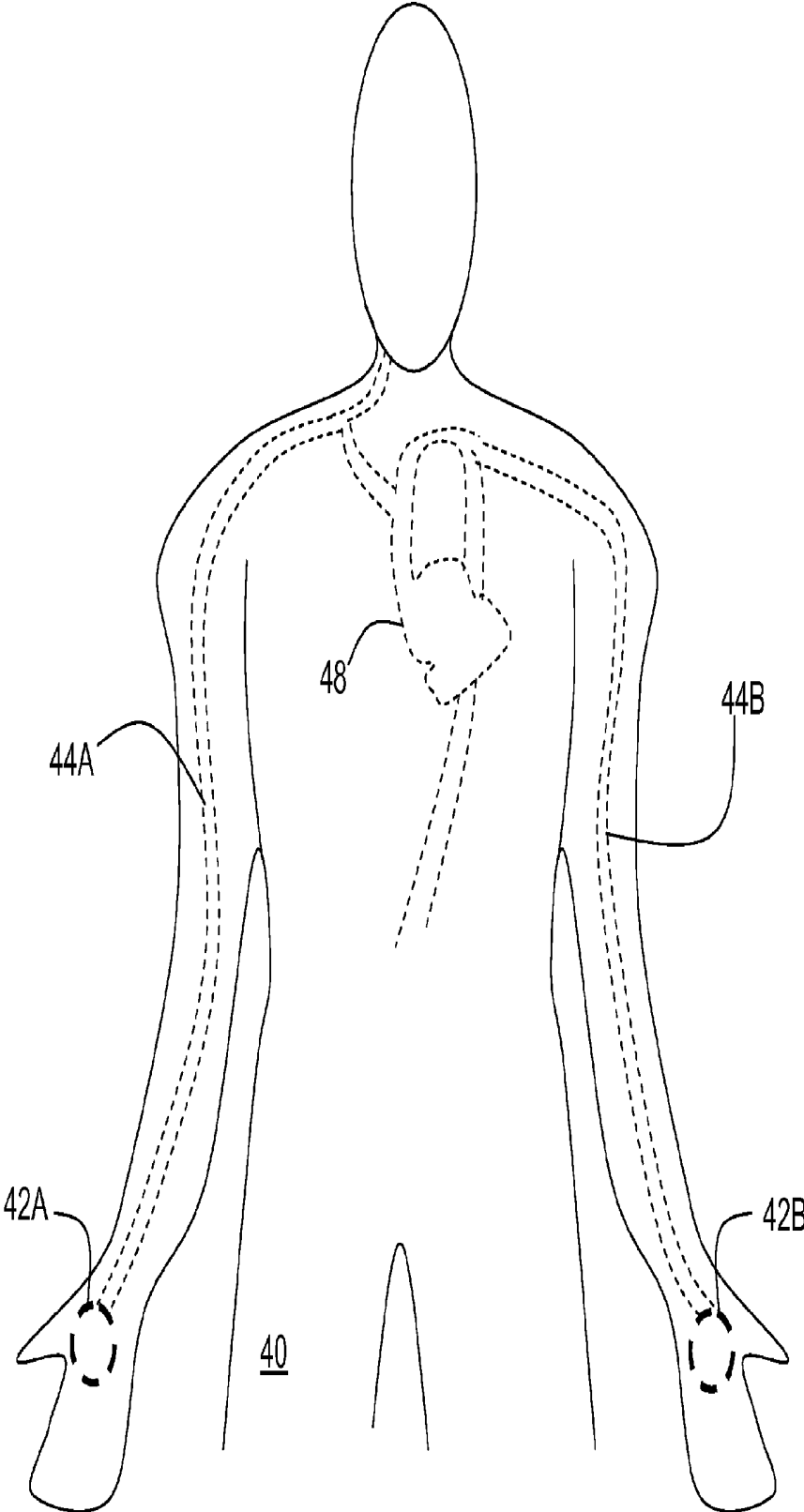

Fig. 2

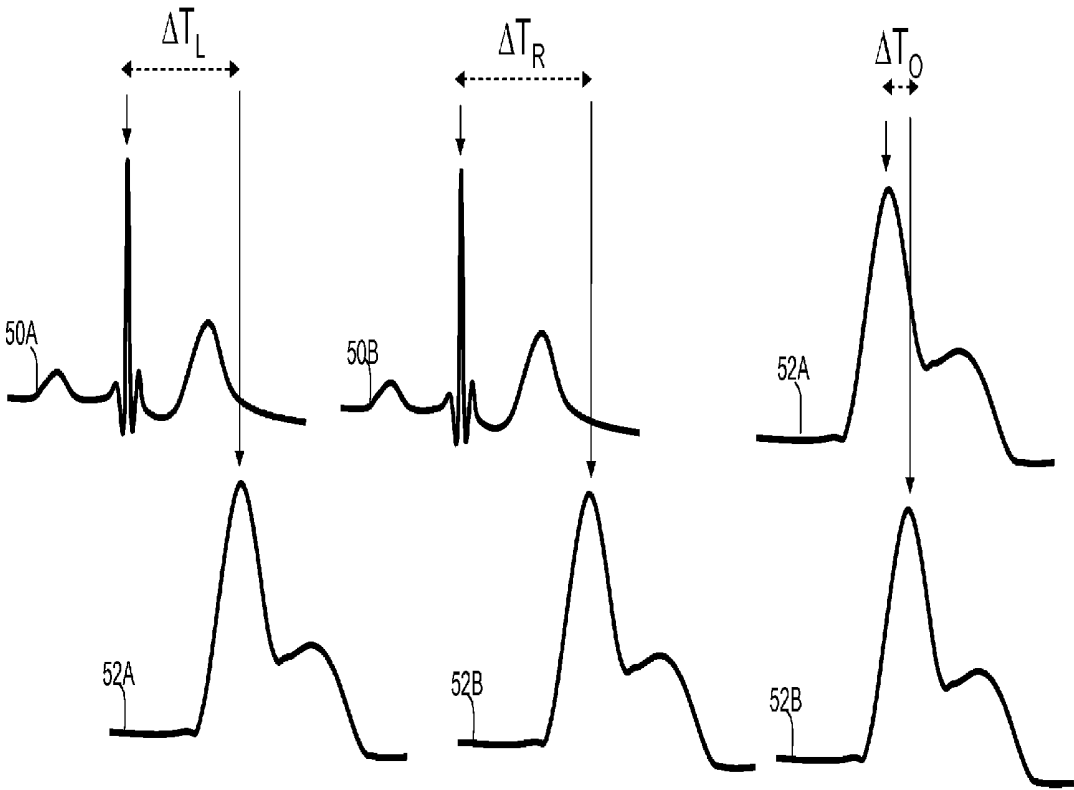

Fig. 3A

Fig. 3B

Fig. 3C

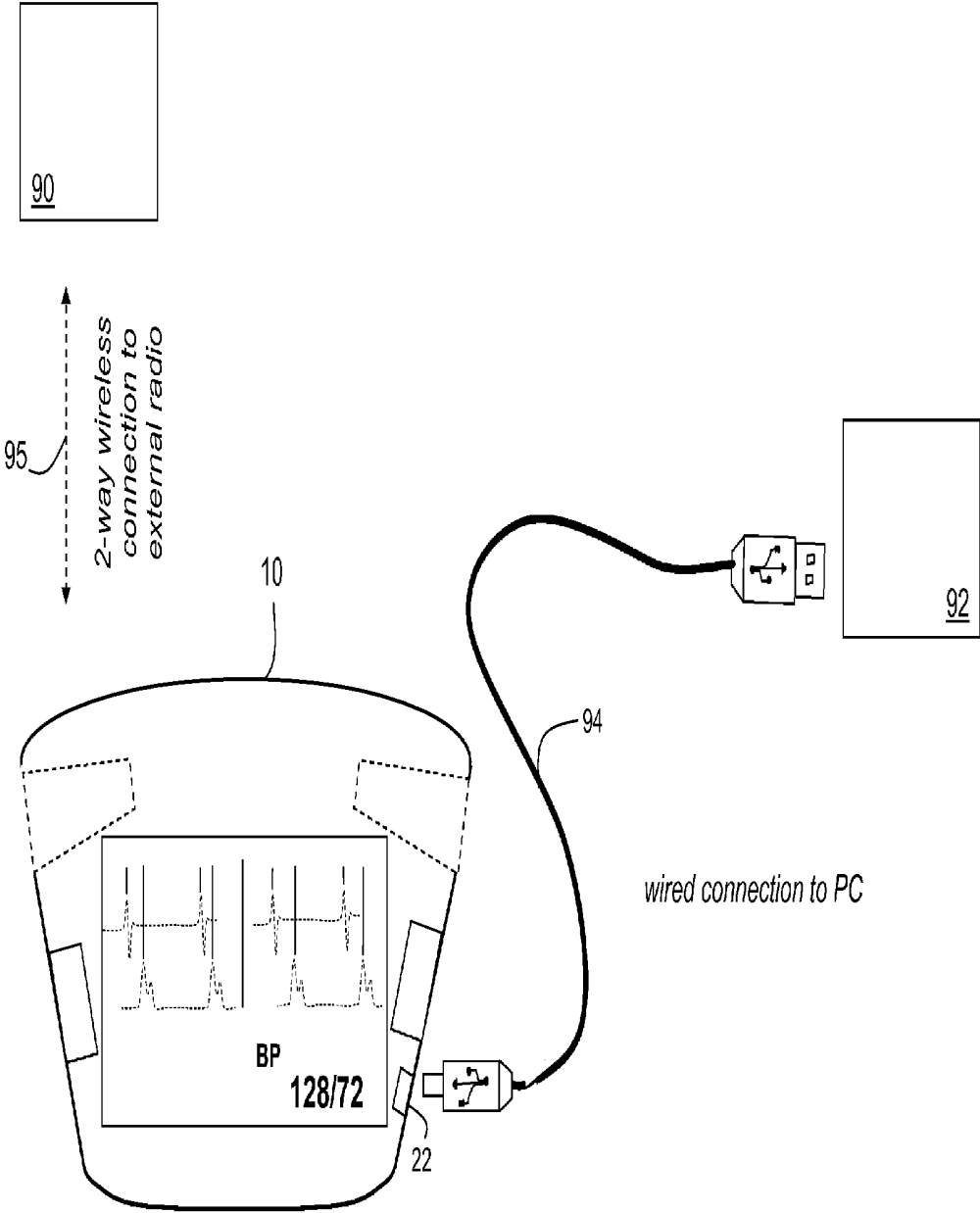

Fig. 4

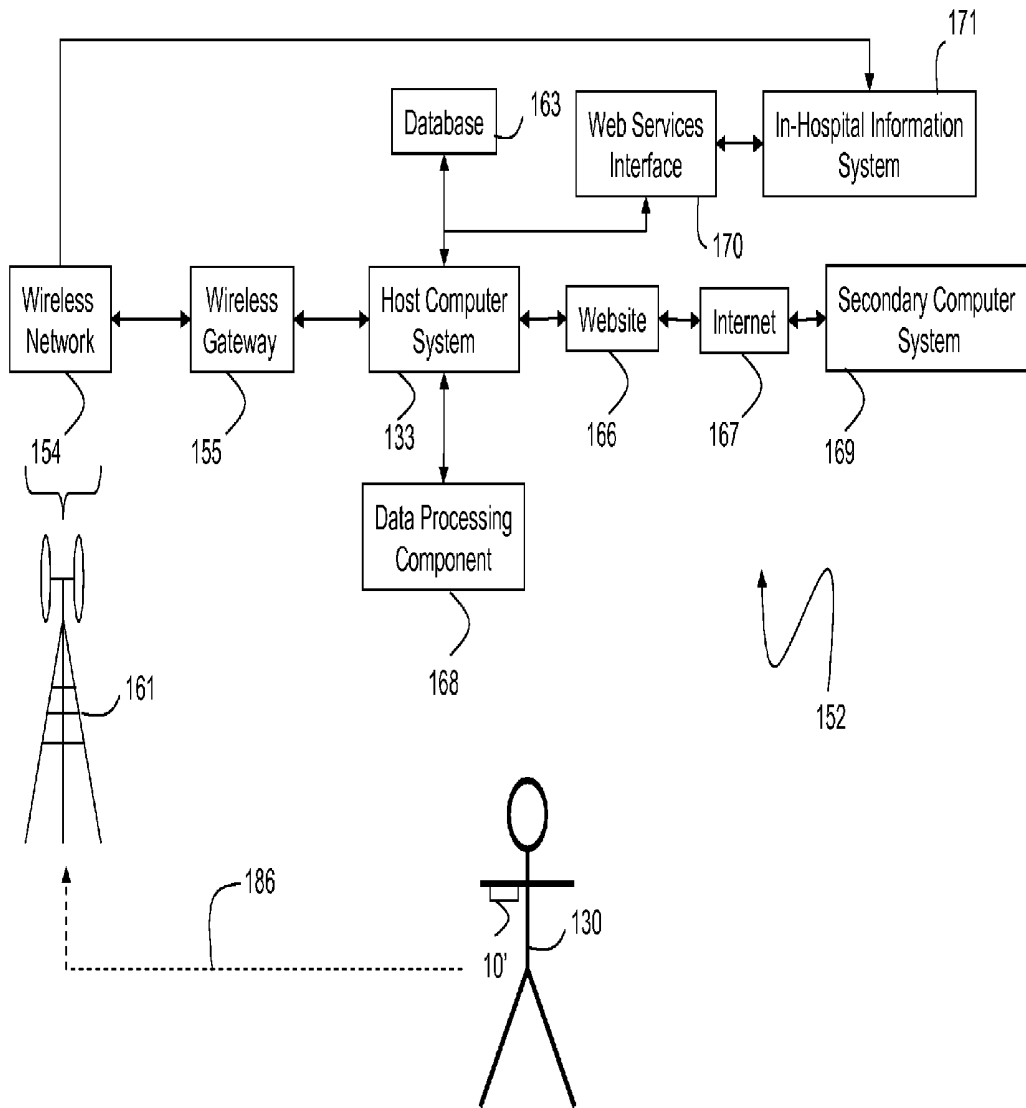

Fig. 5

SYSTEM FOR MEASURING VITAL SIGNS USING BILATERAL PULSE TRANSIT TIME

CROSS-REFERENCE TO RELATED APPLICATIONS

[0001] This application is a divisional of U.S. patent application Ser. No. 11/420,652, filed May 26, 2006, now U.S. Pat. No. 9,149,192, issued Oct. 6, 2015, which is hereby incorporated in its entirety including all tables, figures and claims.

BACKGROUND OF THE INVENTION

[0002] 1. Field of the Invention

[0003] The present invention relates to a system for measuring vital signs, particularly blood pressure, featuring a hand-held, cuffless vital sign monitor.

[0004] 2. Description of Related Art

[0005] Pulse oximeters are medical devices featuring an optical module, typically worn on a patient's finger or ear lobe, and a processing module that analyzes data generated by the optical module. The optical module typically includes first and second light sources (e.g., light-emitting diodes, or LEDs) that transmit optical radiation at, respectively, red ($\lambda \sim 600\text{-}700\text{ nm}$) and infrared ($\lambda \sim 800\text{-}1200\text{ nm}$) wavelengths. The optical module also features a photodetector that detects transmitted radiation that passes through an underlying artery within, e.g., the patient's finger or earlobe. Typically the red and infrared LEDs sequentially emit radiation that is partially absorbed by blood flowing in the artery. The photodetector is synchronized with the LEDs to detect the transmitted radiation. In response, the photodetector generates a separate radiation-induced signal corresponding to each wavelength. The signal, called a plethysmograph, varies in a time-dependent manner as each heartbeat varies the volume of arterial blood and hence the amount of radiation absorbed along the path of light between the LEDs and the photodetector. A microprocessor in the pulse oximeter digitizes and processes plethysmographs generated by the red and infrared radiation to determine the degree of oxygen saturation in the patient's blood using algorithms known in the art. A number between 94%-100% is considered normal, while a number below 85% typically indicates the patient requires hospitalization. In addition, the microprocessor analyzes time-dependent features in the plethysmograph to determine the patient's heart rate.

[0006] Another medical device called an electrocardiograph features conductive electrodes, placed at various locations on a patient's body, that measure electrical signals which pass into an amplification circuit. The circuit generates a waveform called an electrocardiogram, or ECG, that describes a time-dependent response of the patient's cardiovascular system.

[0007] Various methods have been disclosed for using both plethysmographs and ECGs, taken alone or in combination, to measure arterial blood pressure. One such method is disclosed in U.S. Pat. No. 5,140,990 to Jones et al. The '990 patent discloses using a pulse oximeter with a calibrated auxiliary blood pressure measurement to generate a constant that is specific to a patient's blood pressure.

[0008] Another method for using a pulse oximeter to measure blood pressure is disclosed in U.S. Pat. No. 6,616,613 to Goodman. The '613 patent discloses processing a pulse oximetry signal in combination with information from a calibrating device to determine a patient's blood pressure.

[0009] U.S. Pat. Nos. 5,857,795 and 5,865,755 to Golub each disclose a method and device for measuring blood pressure that processes a time difference between points on an optical plethysmograph and an ECG along with a calibration signal.

[0010] U.S. Pat. No. 6,511,436 to Asmar discloses a device for evaluating arterial wall stiffness by using pulse wave velocity measurements. The device estimates blood pressure using pulse wave velocity and a patient's biometric parameters.

[0011] Chen et al, U.S. Pat. No. 6,599,251, discloses a system and method for monitoring blood pressure by detecting plethysmographs at two different locations on a subject's body, preferably on the subject's finger and earlobe. The plethysmographs are detected using conventional pulse oximetry devices and then processed to determine blood pressure.

[0012] Inukai et al., U.S. Pat. No. 5,921,936, discloses a system that uses an electrocardiogram to detect the start of a heart beat and uses a cuff equipped with a pressure sensor to detect pulse waves in order to calculate a pulse transit time.

[0013] Suda et al., U.S. Pat. No. 5,788,634, describes a multi-purpose, clip-on sensor featuring a 'gripper' that includes an electrode pair and an optical system operating in a transmission mode. The electrode pair and optical system generate information that is processed outside of the sensor to make a blood pressure measurement.

[0014] Baruch et al., U.S. Pat. No. 6,723,054, describes an arm-worn system featuring two optical systems that measure two independent signals from a patient's arm. A processor calculates mathematical derivatives of the signals to derive a pulse transit time which can be used to calculate blood pressure.

[0015] Suga et al., U.S. Pat. No. 5,316,008, describes a wrist watch that features both optical and electrical sensors for measuring signals from a patient. During operation, the patient wears the wrist watch on one wrist, and places fingers from an opposing hand on the optical and electrical sensors. A pulse transit time is extracted from the signals and then used to calculate a blood pressure.

BRIEF SUMMARY OF THE INVENTION

[0016] In one aspect, the invention provides a hand-held monitoring device for measuring vital signs (e.g. blood pressure) from a patient that features: i) a housing that encloses a first sensor featuring a first electrode and a first optical system configured to generate a first optical signal; ii) a second sensor featuring a second electrode and a second optical system configured to generate a second optical signal; iii) an amplifier system, in electrical contact with the first and second electrodes, configured to process electrical signals from the first and second electrodes to generate an electrical waveform; and iv) a microprocessor, in electrical communication with the amplifier system, first optical system, and second optical system, the microprocessor configured to process the electrical waveform and first and second optical signals (or processed versions of these signals and waveforms) with an algorithm to determine at least one of the patient's vital signs.

[0017] In preferred embodiments, the light source is an LED or diode laser configured to emit green radiation between 510 and 590 nm. Optical systems which use light sources in this spectral region are referred to herein as 'green optical systems'. In other preferred embodiments, the optical system is configured to operate in a reflection-mode geom-

etry, e.g. both the light source and photodetector are disposed on a same side of the substrate (e.g., a printed circuit board). In this case the photodetector is aligned to detect radiation first emitted from the light source and then reflected from the patient's tissue to generate the optical waveform.

[0018] The optical system and electrodes are typically housed within a hand-held or body-worn device. In this configuration, the electrical and optical sensors are typically oriented to measure electrical and optical signals from at least one of the patient's fingers. In still other embodiments, the monitoring device additionally includes an amplifier system (e.g. a two-stage amplifier system) configured to process the first and second electrical signals to generate an electrical waveform. The device can also use this same amplifier system, or a different amplifier system, to process the optical signals to generate an optical waveform. Alternatively, the electrical and optical sensors may be housed in distinct units that are in electronic communication with the housing containing the amplifier system and the microprocessor.

[0019] Alternatively, the first and second optical systems may be replaced by other sensor systems capable of identifying a time-dependent arrival of a pulse. Examples of other sensor systems that are capable of measuring pulse waves include tonometric sensor systems, ultrasound sensor systems, magnetic field sensor systems and oscillometric cuffs. The use of one of these alternative pulse detection systems enables the identification of a first and second pulse signal that can be used in place of the first and second optical signal, and in combination with the electrical waveform and an algorithm, to calculate at least one of the patient's vital signs.

[0020] In other alternate embodiments, calibration parameters are based on biometric data, e.g., height, arm span, weight, body mass index, and age. The calibration parameters may not be specific to an individual patient, but rather determined for a general class of patients. For example, the calibration parameters are based on correlations between blood pressure and features in the optical or electrical waveforms observed in the analysis of clinical data sets. Conjunctively, the calibration parameters may be based on correlations between biometric parameters and features in the optical or electrical waveforms observed in the analysis of clinical data sets.

[0021] In embodiments, the microprocessor or microcontroller within the monitor runs computer code or 'firmware' that determines blood pressure by processing: 1) a first time-dependent feature of the optical waveform; 2) a second time-dependent feature of the electrical waveform; and 3) a calibration parameter. In this case the calibration parameter is determined by a conventional device for measuring blood pressure, such as a blood pressure cuff.

[0022] In other embodiments, the system features a first light source that emits green radiation to generate a first optical waveform, and a second light source that emits infrared radiation to generate a second optical waveform. In this case the device runs computer code or firmware that processes the first and second optical waveforms to generate a pulse oximetry value using techniques that are known in the art. In a related embodiment, the device can run computer code or firmware that processes the optical waveform to generate a heart rate value. In yet another embodiment, the device can run computer code or firmware that processes the first and second electrical signals to generate an ECG waveform, which can then be processed to calculate a heart rate.

[0023] In another aspect, the invention provides a hand-held device for measuring vital signs (e.g. blood pressure) from a patient that features: i) a housing; ii) a first optical system, enclosed by the housing, configured to generate a first optical signal; iii) a second optical system, also enclosed by the housing, configured to generate a second optical signal; and iv) a microprocessor, in electrical communication with the first optical system and second optical system, the microprocessor configured to process the first and second optical signals with an algorithm to determine at least one of the patient's vital signs.

[0024] In yet another aspect, the invention provides a hand-held device for measuring vital signs (e.g. blood pressure) from a patient that features: i) a first optical system at a first location on a subject and configured to generate a first optical signal; ii) a second optical system at a second location on a subject that is approximately mirror-symmetric about the patient's sagittal plane (i.e. a plane representing the median plane of the patient's body) to that of the first location and configured to generate a second optical signal; and iii) a microprocessor, in electrical communication with the first optical system and second optical system, the microprocessor configured to process the first and second optical signals with an algorithm to determine at least one of the patient's vital signs. Examples of locations of the first and second optical systems, respectively, include the left ear lobe and right ear lobe, the left radial artery at the subject's left wrist and the right radial artery at the subject's right wrist, any left-hand finger and any right-hand finger, any left-foot toe and any right-foot toe.

[0025] In another aspect, the invention describes a method of calculating a patient's blood pressure, comprising the steps of: i) detecting an electrical waveform corresponding to the potential difference between a first electrode at a first location on a subject and a second electrode at a second location on a subject; ii) detecting a first pulse signal on a subject and calculating a first time difference between the occurrence of a first feature on the electrical waveform and a second feature on the first pulse signal; iii) detecting a second pulse signal on a subject and calculating a second time difference between the second pulse signal and the first pulse signal; and iv) calculating the subject's blood pressure using the first time difference, the second time difference, and an algorithm relating those time differences to blood pressure. The second time difference may be calculated as a time difference between a first feature on the first pulse signal and a second pulse feature on the second pulse signal. Alternatively, the second time difference may be calculated as the time delay measured using the cross correlation between the first pulse signal and the second pulse signal. The first and second pulse signals may additionally be mathematically transformed (e.g., derivatized, averaged).

[0026] The invention has many advantages. In particular, through use of an optical system operating in a reflection-mode geometry and based on a green light source, the invention measures optical waveforms that are relatively insensitive to motion-related artifacts and have a high signal-to-noise ratio, particularly when compared to waveforms measured using red or infrared radiation in a similar geometry.

[0027] In a more general sense, the invention provides an easy-to-use, low-profile system that measures a variety of vital signs, including blood pressure, without using a cuff.

[0028] This and other information can be easily transferred to a central device through a wired or wireless connection to

better characterize a patient. Using the system of the invention, information describing the patient's blood pressure can be viewed using an Internet-based website, personal computer, or a mobile device. Blood-pressure information measured throughout the day provides a relatively comprehensive data set compared to that measured during isolated medical appointments. For example, this approach identifies trends in a patient's blood pressure, such as a gradual increase or decrease, which may indicate a medical condition that requires treatment.

[0029] Having briefly described the present invention, the above and further objects, features and advantages thereof will be recognized by those skilled in the pertinent art from the following detailed description of the invention when taken in conjunction with the accompanying drawings.

BRIEF DESCRIPTION OF THE DRAWINGS

[0030] FIG. 1 is a schematic view of the hand-held monitoring device for measuring vital signs according to the invention;

[0031] FIG. 2 is a schematic view of a patient's bilateral blood flow from the heart to the left and right sides of the body;

[0032] FIG. 3A shows graphs of optical and electrical waveforms generated with a first sensor;

[0033] FIG. 3B shows a second sensor;

[0034] FIG. 3C shows optical waveforms generated from both the first and second sensors included in the monitor of FIG. 1;

[0035] FIG. 4 is a semi-schematic view of the monitoring device of FIG. 1 connected to a personal computer through a USB port or to an external radio through a wireless connection; and,

[0036] FIG. 5 is a schematic view of an Internet-based system that receives information from the monitoring device of FIG. 1 through a wireless connection.

DETAILED DESCRIPTION OF THE INVENTION

[0037] FIG. 1 shows a hand-held vital signs monitoring device 10 according to the invention that measures blood pressure and other vital signs from a patient's fingers 13A, 13B (e.g., the index finger, thumb finger, etc.) using a technique referred to herein as 'bilateral pulse transit time', or BPTT. Blood pressure measured using BPTT may be more accurate than blood pressure measured using a technique based on conventional pulse transit time. To make a BPTT measurement, the patient holds the device 10 with both hands, gently inserting and pressing their left index finger 13A inside a left sensor enclosure 14A, and their right index finger 13B inside a right sensor enclosure 14B. Both the left 14A and right 14B sensor enclosures feature an LED system 15A, 15B, 61A, 61B, 62A, 62B that generates optical radiation at one or more wavelengths, and a photodetector 16A, 16B that detects radiation either reflected or transmitted from an artery in the inserted finger 13A, 13B. Each LED system 15A, 15B typically includes a green LED operating in reflection mode and red 61A, 61B and infrared 62A, 62B LEDs operating in transmission modes. An electrical system within the device detects and amplifies radiation from each index finger, as described in detail below. This generates time-resolved optical waveforms 29A, 29B, specific to each index finger, which are shown respectively on left 28A and right 28B portions of a display 18. The optical waveforms, called an 'optical

plethysmograph', are described in more detail below with reference to FIGS. 3A, 3B, and 3C. Each sensor enclosure 14A, 14B also includes a conductive electrode pad 17A, 17B that measures an electrical signal when in contact with the inserted finger 13A, 13B. The electrode pad 17A, 17B, for example, can be made of metal (e.g., brass), conductive rubber, or a conventional electrode material such as silver/silver chloride. Once generated, the electrical signals are processed with an amplifier circuit and then digitized to generate an electrical waveform 31A, 31B, similar to a conventional ECG, which is also shown on the left 28A and right 28B portions of the display 18. Unlike the optical waveforms 29A, 29B, which specifically correspond to blood flowing in each index finger, a single electrical waveform 29A, 29B is determined by jointly processing electrical signals measured from each index finger using the amplifier circuit.

[0038] The device 10 measures blood pressure using BPTT by processing optical waveforms 29A, 29B and electrical waveforms 31A, 31B measured from each finger 13A, 13B or thumb 12A, 12B. Each waveform features a 'pulse' that corresponds to each of the patient's heartbeats. In the electrical waveforms 31A, 31B, this pulse represents electrical signals generated by the beating heart, and features a sharply varying feature within a conventional QRS complex of the ECG waveform. In contrast, for the optical waveforms 29A, 29B, the pulse varies more gradually and represents a time-dependent volumetric change in an underlying artery. A microprocessor in the device 10 calculates a pulse transit time ('PTT'), described in more detail with reference to FIGS. 3A, 3B, 3C, by analyzing a time difference ΔT between a point on the optical 29A, 29B and electrical 31A, 31B waveforms (e.g., the peaks of these waveforms), along with other properties described in more detail below. ΔT measured from the optical waveform 29A from the left index finger 13A and the electrical waveform 31A for two heartbeats are shown in the left-hand portion 28A of the display, and are labeled ' $\Delta T_{L,1}$ ' and ' $\Delta T_{L,2}$ '. Similarly, time differences measured from the optical waveform 29B from the right index finger 13B and the electrical waveform 31B for two heartbeats are shown in the right-hand portion 28B of the display, and are labeled ' $\Delta T_{R,1}$ ' and ' $\Delta T_{R,2}$ '.

[0039] Referring to FIGS. 2 and 3A, 3B, 3C, the hand-held device 10 measures blood pressure using BPTT by processing optical waveforms 52A, 52B and electrical waveforms 50A, 50B measured simultaneously from each side of the patient's body. Each waveform includes a 'pulse' that corresponds to each of the patient's heartbeats. In the electrical waveforms 50A, 50B, this pulse represents electrical signals generated by the beating heart, and includes a sharply varying 'peak' within a conventional QRS complex of the ECG. In contrast, for the optical waveforms 52A, 52B, the pulse varies more gradually and represents a time-dependent volumetric change in an underlying artery. A microprocessor in the device 10 calculates a pulse transit time ('PTT'), described in more detail below, by analyzing a time difference ΔT between a point on the optical 52A, 52B and electrical 50A, 50B waveforms (e.g., ΔT between the peaks of these waveforms). Specific points on the waveforms, such as their maxima or minima, can be determined by taking a first or second derivative of the waveform. ΔT measured from the optical waveform 52A from the patient's left index finger and the electrical waveform 50A is shown in FIG. 3A (labeled ΔT_L). Similarly,

ΔT measured from the optical waveform **52B** from the right index finger and the electrical waveform **50B** is shown in FIG. 3B (labeled ΔT_R).

[0040] The BPTT measurement processes PTTs measured with the finger clip sensors from the patient's left finger (ΔT_L) and right finger (ΔT_R) to make an accurate measurement of blood pressure. Specifically, PTT depends on several factors, including blood pressure, distance between the heart and the portion of the body where the optical waveform is measured (e.g., the patient's finger), and properties of the patient's vasculature (e.g., arterial compliance, size, and stiffness).

[0041] BPTT as described herein can potentially improve the accuracy of a normal PTT measurement. For example, as shown in FIG. 2, a patient's heart **48** is typically located in a relatively well-defined position on the left-hand side of their chest cavity. With each heartbeat, blood simultaneously flows along a right-hand vascular pathlength **44A** to reach a point **42A** on the patient's right hand, and along a left-hand vascular pathlength **44B** to reach a point **42B** on the patient's left hand. The right-hand vascular pathlength **44A** typically differs from the left-hand vascular pathlength **44B**. The difference in pathlengths can correlate with the patient's biometric parameters (e.g., height, arm span). The difference in pathlengths and corresponding difference in PTTs can be used in the calculation of the patient's vital signs (e.g., blood pressure), as is described in more detail below.

[0042] Following a heartbeat, electrical impulses travel essentially instantaneously from the patient's heart to electrodes within each sensor enclosure (e.g., the left **14A** and right **14B** sensor enclosures in FIG. 1), which detect it to generate an electrical waveform. At a later time, a pressure wave induced by the same heartbeat simultaneously propagates through the patient's right-hand **44A** and left-hand **44B** vascular pathlengths. At points **42A**, **42B** on the patient's left and right hands, elastic arteries within these vascular pathlengths increase in volume due to the pressure wave. Ultimately the pressure wave arrives at a portion of the artery underneath the LED and photodetector within each sensor enclosure. These optics combine to form an optical system that detects the pressure wave by measuring a time-dependent change in optical absorption. The propagation time of the electrical impulse is independent of blood pressure, whereas the propagation time of the pressure wave depends strongly on pressure, as well as properties of the patient's arteries.

[0043] Referring again to FIGS. 3A, 3B, and 3C, during a BPTT measurement, optical sensors within the right and left sensor enclosures simultaneously measure optical waveforms **52A**, **52B**, while electrodes in the sensors measure electrical waveforms **50A**, **50B**. The optical waveforms **52A**, **52B** are unique to each area enclosed by the sensor enclosure, while the electrical waveforms **50A**, **50B** are identical, and are determined by combining electrical signals from the left and right-hand sensor enclosures. A microprocessor within the device runs an algorithm that analyzes the time difference $\Delta T_{L,R}$ between the arrivals of these signals, i.e. the relative occurrence of the optical **52A**, **52B** and electrical **50A**, **50B** waveforms for both the right-hand **44A** and left-hand **44B** vascular system. The microprocessor additionally analyzes the time difference ΔT_O between the arrival of the two optical signals **52A**, **52B**.

[0044] In a BPTT measurement, the asymmetric position of the heart, coupled with the assumption that blood pressure is equivalent along the left-hand **44B** and right-hand **44A** vascular pathlengths, means the PTT for the right-hand path-

length **44A** will typically be slightly longer than the PTT for the left-hand pathlength **44B**. This time difference, ΔPTT , is the difference between ΔT_L and ΔT_R (i.e. $\Delta PTT = \Delta T_R - \Delta T_L$) and can be used to estimate the patient's arm length if a speed of the propagating pressure pulse, called a pulse wave velocity ('PWV') is assumed. Inclusion of arm length in a PTT-based measurement typically improves accuracy for both systolic and diastolic blood pressure. Use of BPTT to determine ΔPTT means arm length can be estimated without having to enter it through a software user interface. Alternatively, the arm length can be entered into a user interface associated with the monitor, and then processed along with ΔPTT to calculate a PWV. This is done by using the above-described assumptions describing the asymmetrical position of the heart. Blood pressure is known to depend strongly on PWV (typically an increase in PWV indicates an increase in blood pressure), and thus a measured PWV value can be compared to a look-up table stored in memory to calculate blood pressure. Alternatively, a mathematical algorithm, such as a predetermined relationship (e.g., a linear relationship) between PWV and blood pressure, may be used to calculate subsequent blood pressure values.

[0045] Referring to FIG. 3C, in another embodiment the time difference ΔT_O between points (e.g., peaks) on two optical signals measured from the patient's left and right hands can be processed to determine a PWV. For example, ΔT_O can be correlated to PWV and blood pressure using a predetermined relationship (e.g. a linear relationship) before making a measurement, and this correlation can be stored in a look-up table in memory on the device. The device may use an algorithm to convert ΔT_O to blood pressure for subsequent measurements.

[0046] In addition, with the BPTT measurement, optical waveforms measured from the patient's left and right hands or ΔPTT can be compared to determine slight differences in waveform shape. These slight differences can then be processed to achieve a more accurate calculation of the patient's blood pressure. For example, the differences in left and right waveform shapes or arrival times measured as described above can be used to determine a particular mathematical model for calculating blood pressure from a patient, or alternatively properties other than blood pressure. An abnormally high or negative ΔPTT , for example, may indicate a profound difference between a patient's right-hand **44A** and left-hand **44B** vascular pathlength. Such a difference, for example, may indicate the presence of an occlusion (e.g., a blood clot) or stenosis in either vascular pathlength. In related embodiments, the ΔPTT or waveform shape differences may be used to estimate a patient's arterial compliance.

[0047] For example, the differences in the patient's right-hand **44A** and left-hand **44B** vascular pathlengths will result in corresponding differences in the diffusion of light-absorbing blood cells in the two pathlengths. These differences in cellular diffusion are observed as differences in the shapes of the optical waveforms **52A** and **52B**. The waveform shape differences will depend on the arterial compliance along the right-hand **44A** and left-hand **44B** vascular pathlengths. For example, the optical signals **52A**, **52B** shown in FIGS. 3A, 3B, 3C typically feature a main peak and a secondary peak, where the secondary peak is typically classified as a 'dichrotic notch'. Studies published in the literature describe how the dichrotic notch, particularly when analyzed by taking a second derivative of the plethysmogram, relates to vascular compliance (see, e.g., 'Assessment of Vasoactive Agents and

Vascular Aging by the Second Derivative of Photoplethysmogram Waveform', Takazawa et. al, Hypertension 32: 365-370, 1998; the contents of which are incorporated herein by reference). Arterial compliance determined using this or another method can then be used to group patients having similar arterial properties. An algorithm can then process ΔPTT or PWV values for patients in a particular group, or compare these values to predetermined look-up tables, to make a blood pressure measurement. For example, the algorithm may use a predetermined relationship (e.g. a linear relationship) between PWV or ΔPTT and blood pressure to calculate subsequent blood pressure values.

[0048] Referring again to FIGS. 3A, 3B, and 3C, in yet another embodiment, processing the electrical waveform 50A, 50B and optical waveforms 52A, 52B can be used to estimate a property called pre-ejection period (' ΔT_{PEP} '), which is the time delay between the beginning of a patient's heart beat and the beginning of the patient's cardiac stroke. Specifically, both ΔT_R and ΔT_L depend on ΔT_{PEP} and the time it takes the pressure pulse to leave the heart and arrive at the optical system underneath a corresponding sensor. As shown in FIG. 3C, this time difference, referred to as ΔT_O , can be measured directly from sensors located near the patient's heart and finger. If the sensor is located on the patient's right hand, $\Delta T_R - \Delta T_O = \Delta T_{PEP}$, while if the sensor is located on the patient's left hand $\Delta T_L - \Delta T_O = \Delta T_{PEP}$ correlates with the patient's systolic function, with a shorter ΔT_{PEP} typically indicating a relatively healthy systolic function. A measured ΔT_{PEP} can be used in conjunction with the time difference between a feature on the electrical waveform and one or more features on one or more optical waveforms to improve the accuracy of the calculated PTT and corresponding blood pressure. In particular, it has been shown in previous studies that systolic blood pressure can correlate better to a ΔPTT value, whereas diastolic blood pressure and mean arterial blood pressure can correlate better to a ΔPTT value corrected for ΔT_{PEP} , i.e. $\Delta PTT - \Delta T_{PEP}$ (see, e.g., 'Pulse transit time measured from the ECG: an unreliable marker of beat-to-beat blood pressure', Payne et. al, J. Appl. Physiol 100: 136-141, 2006; the contents of which are incorporated herein by reference). ΔT_{PEP} values may also vary with respiration and inspiration, thereby affecting the measured blood pressure. For this reason, in embodiments, computer code operating in the monitor described above can first process two optical waveforms to estimate ΔT_{PEP} . Once this is done, the computer code can determine ΔPTT and $\Delta PTT - \Delta T_{PEP}$, which are then used to calculate, respectively, systolic and diastolic blood pressure.

[0049] Referring to FIG. 4, to transfer information to Internet-accessible devices, the device 10 includes a mini USB port 22 that connects to a personal computer 92 through a conventional USB connector terminating a first cable 94. Alternatively, the device 10 connects to an external radio 90 through a 2-way radio connection. The external radio 90, for example, could be within the personal computer 92 or another device, such as a scale, chest strap, or additional monitor.

[0050] FIG. 5 shows a preferred embodiment of an Internet-based system 152 that operates in concert with the device 10 and to send information from a patient 130 to an in-hospital information system 171 (e.g., a system for electronic medical records). During operation, the device 10 collects vital sign information from the patient 130 and, using an internal radio as described above, transmits information through a wireless interface 186 to a wireless network 154

(e.g., either a nation-wide or local wireless network), and from there to a web site 166 hosted on an Internet-based host computer system 133. A secondary computer system 169 accesses the website 166 through the Internet 167. A wireless gateway 155 connects to the host computer system 133 and ultimately to the wireless network 154, and receives data from one or more monitors, as discussed below. The host computer system 133 includes a database 163 and a data-processing component 168 for, respectively, storing and analyzing data sent from the monitor. The host computer system 133, for example, may include multiple computers, software systems, and other signal-processing and switching equipment, such as routers and digital signal processors. The wireless gateway 155 preferably connects to the wireless network 154 using a TCP/IP-based connection, or with a dedicated, digital leased line (e.g., a VPN, frame-relay circuit or digital line running an X.25 or other protocols). The host computer system 133 also hosts the web site 166 using conventional computer hardware (e.g. computer servers for both a database and the web site) and software (e.g., web server and database software). To connect to the in-hospital information system 171, the host computer system 133 typically includes a web services interface 170 that sends information using an XML-based web services link to a computer associated with the in-hospital information system 171. Alternatively, the wireless network 154 may be an in-hospital wireless network (e.g., a network operating Bluetooth™, 802.11a, 802.11b, 802.1g, 802.15.4, or 'mesh network' wireless protocols) that connects directly to the in-hospital information system 171. In this embodiment, a nurse working at a central nursing station can quickly view the vital signs of the patient using a simple computer interface.

[0051] To view information remotely, the patient or medical professional can access a user interface hosted on the web site 166 through the Internet 167 from a secondary computer system 169, such as an Internet-accessible home computer. The system may also include a call center, typically staffed with medical professionals such as doctors, nurses, or nurse practitioners, whom access a care-provider interface hosted on the same website 166.

[0052] The device 10 can optionally be used to determine the patient's location using embedded position-location technology (e.g., GPS, network-assisted GPS, or Bluetooth™ 802.11-based location system). In situations requiring immediate medical assistance, the patient's location, along with relevant vital sign information, can be relayed to emergency response personnel.

We claim as our invention:

1. A device for measuring a patient's vital signs, comprising:
 - a housing;
 - a first sensor, attached to the housing, comprising a first electrode and a first optical system configured to generate a first optical signal;
 - a second sensor, attached to the housing, comprising a second electrode;
 - an amplifier system, in electrical contact with the first and second electrodes, configured to process electrical signals from the first and second electrodes to generate an electrical waveform; and,
 - a microprocessor, in electrical communication with the amplifier system and first optical system, the microprocessor configured to process the electrical waveform and

- first optical signal, or at least one derivative thereof, with an algorithm to determine at least one of the patient's vital signs.
2. The device of claim 1, wherein the second sensor further comprises a second optical system configured to generate a second optical signal.
3. The device of claim 1, wherein the first sensor further comprises an electrically conductive electrode proximal to the first optical system.
4. The device of claim 3, wherein the first optical system further comprises a first light source and a first photodetector.
5. The device of claim 4, wherein the first light source and the first photodetector are attached to a common substrate.
6. The device of claim 5, wherein the first photodetector is further configured to receive radiation from the light source after it reflects off one of the patient's fingers.
7. The device of claim 2, wherein the second sensor further comprises an electrically conductive electrode proximal to the second optical system.
8. The device of claim 7, wherein the second optical system further comprises a second light source and a second photodetector.
9. The device of claim 8, wherein the second light source and the second photodetector are attached to a common substrate.
10. The device of claim 9, wherein the second photodetector is further configured to receive radiation from the light source after it reflects off one of the patient's fingers.
11. The device of claim 2, wherein the first sensor attaches to a left-hand side of the housing, and the second sensor attaches to a right-hand side of the housing.
12. The device of claim 11, wherein the housing further comprising a first opening that comprises first sensor, and a second opening that comprises the second sensor.
13. The device of claim 11, further comprising a hand-held housing configured so that, when held by the patient, the patient's left hand contacts the first sensor, and the patient's right hand contacts the second sensor.
14. The device of claim 1, wherein the first optical signal is an optical waveform, and further comprising a microprocessor configured to process the optical waveform and the electrical waveform, or derivatives thereof, to determine a time difference.
15. The device of claim 14, further comprising a microprocessor configured to further process the time difference to determine a blood pressure.
16. The device of claim 1, further comprising a microprocessor configured to process at least one of the electrical waveform and first optical signal, or at least one derivative thereof, to determine a heart rate.
17. The device of claim 1, further comprising a display.
18. The device of claim 17, wherein the microprocessor is further configured to render at least one of the electrical waveform and first optical signal on the display.
19. The device of claim 1, further comprising a wireless system configured to wirelessly transmit at least one of the patient's vital signs to an external receiver.

* * * * *

专利名称(译)	使用双侧脉冲传输时间测量生命体征的系统		
公开(公告)号	US20160022224A1	公开(公告)日	2016-01-28
申请号	US14/875487	申请日	2015-10-05
[标]申请(专利权)人(译)	索泰拉无线公司		
申请(专利权)人(译)	SOTERA WIRELESS, INC.		
当前申请(专利权)人(译)	SOTERA WIRELESS, INC.		
[标]发明人	BANET MATTHEW JOHN THOMPSON MICHAEL JAMES ZHOU ZHOU VISSER II HENK HUNT ROBERT KENNETH		
发明人	BANET, MATTHEW JOHN THOMPSON, MICHAEL JAMES ZHOU, ZHOU VISSER, II, HENK HUNT, ROBERT KENNETH		
IPC分类号	A61B5/00 A61B5/021 A61B5/024 A61B5/0245 A61B5/04		
CPC分类号	A61B5/7278 A61B5/04 A61B5/6826 A61B5/02125 A61B2562/16 A61B5/0245 A61B5/742 A61B5/0004 A61B5/02416 A61B5/021 A61B5/02438 A61B5/1455 A61B5/6838 A61B5/7239 A61B2560/0462 A61B2560/0468		
其他公开文献	US9622710		
外部链接	Espacenet USPTO		

摘要(译)

本发明提供了一种用于在不使用袖带的情况下测量患者的血压和其他生命体征的监视器。本发明提供一种用于测量来自患者的生命体征(例如血压)的手持装置,其特征在于:i)包围第一传感器的壳体,所述第一传感器包括第一电极和配置成产生第一光学信号的第一光学系统;ii)第二传感器,其包括第二电极和第二光学系统,第二光学系统被配置为产生第二光学信号;iii)放大器系统,与第一和第二电极电接触,配置成处理来自第一和第二电极的电信号以产生电波形;iv)微处理器,与放大器系统,第一光学系统和第二光学系统电连通,微处理器配置成用算法处理电波形和第一和第二光信号,以确定患者的至少一个生命体征。

