



US 20150257674A1

(19) **United States**
(12) **Patent Application Publication**
Jordan et al.

(10) **Pub. No.: US 2015/0257674 A1**
(43) **Pub. Date: Sep. 17, 2015**

(54) **WIRELESS EEG UNIT**

Publication Classification

(71) Applicant: **JORDAN NEUROSCIENCE, INC.**,
Redlands, CA (US)
(72) Inventors: **Kenneth George Jordan**, Irvine, CA
(US); **Gary Loubert**, Kanata (CA);
David Bakkom, Cedar Grove, WI (US)

(51) **Int. Cl.**
A61B 5/0478 (2006.01)
A61B 5/00 (2006.01)
A61B 5/04 (2006.01)
A61B 6/03 (2006.01)
(52) **U.S. Cl.**
CPC *A61B 5/0478* (2013.01); *A61B 6/032*
(2013.01); *A61B 5/0006* (2013.01); *A61B*
5/04012 (2013.01)

(21) Appl. No.: **14/435,728**

(22) PCT Filed: **Oct. 15, 2013**

(86) PCT No.: **PCT/US13/65138**

§ 371 (c)(1),

(2) Date: **Apr. 14, 2015**

(57) **ABSTRACT**

A device for performing EEG which consists of an elastic head strap, electrodes, and a wireless transmitter. The wireless transmitter, which displays indicators of electrode impedance, is secured to a patient using a docking station attached to the head strap at the crown of a subject's head and is placed into electrical communication with the electrodes using conductive thread sewn into the head strap. A simplified user interface comprising graphical elements improves the detection of brain wave patterns.

Related U.S. Application Data

(60) Provisional application No. 61/713,754, filed on Oct. 15, 2012.

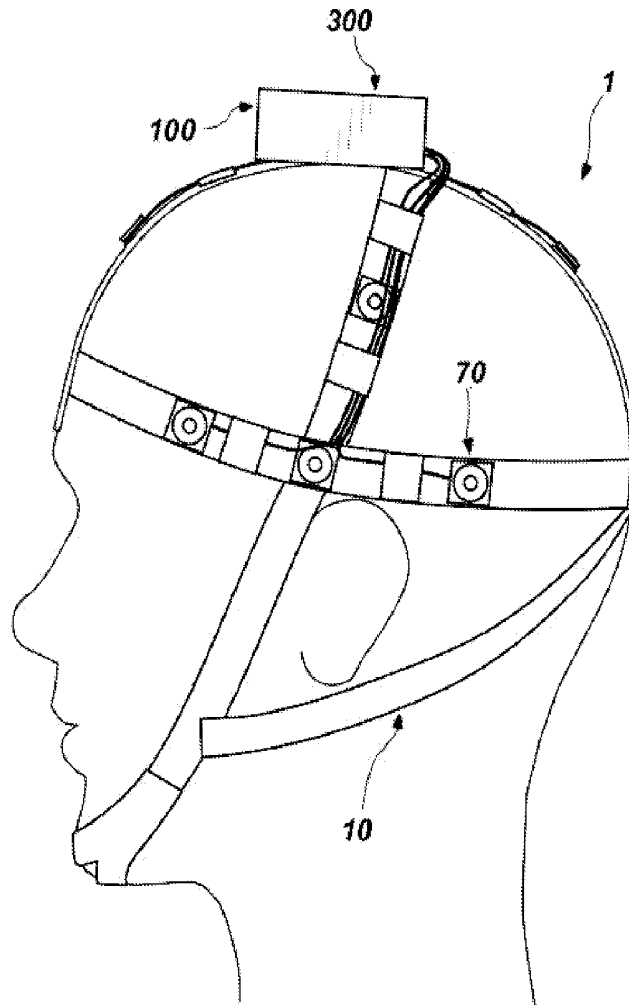

Figure 1

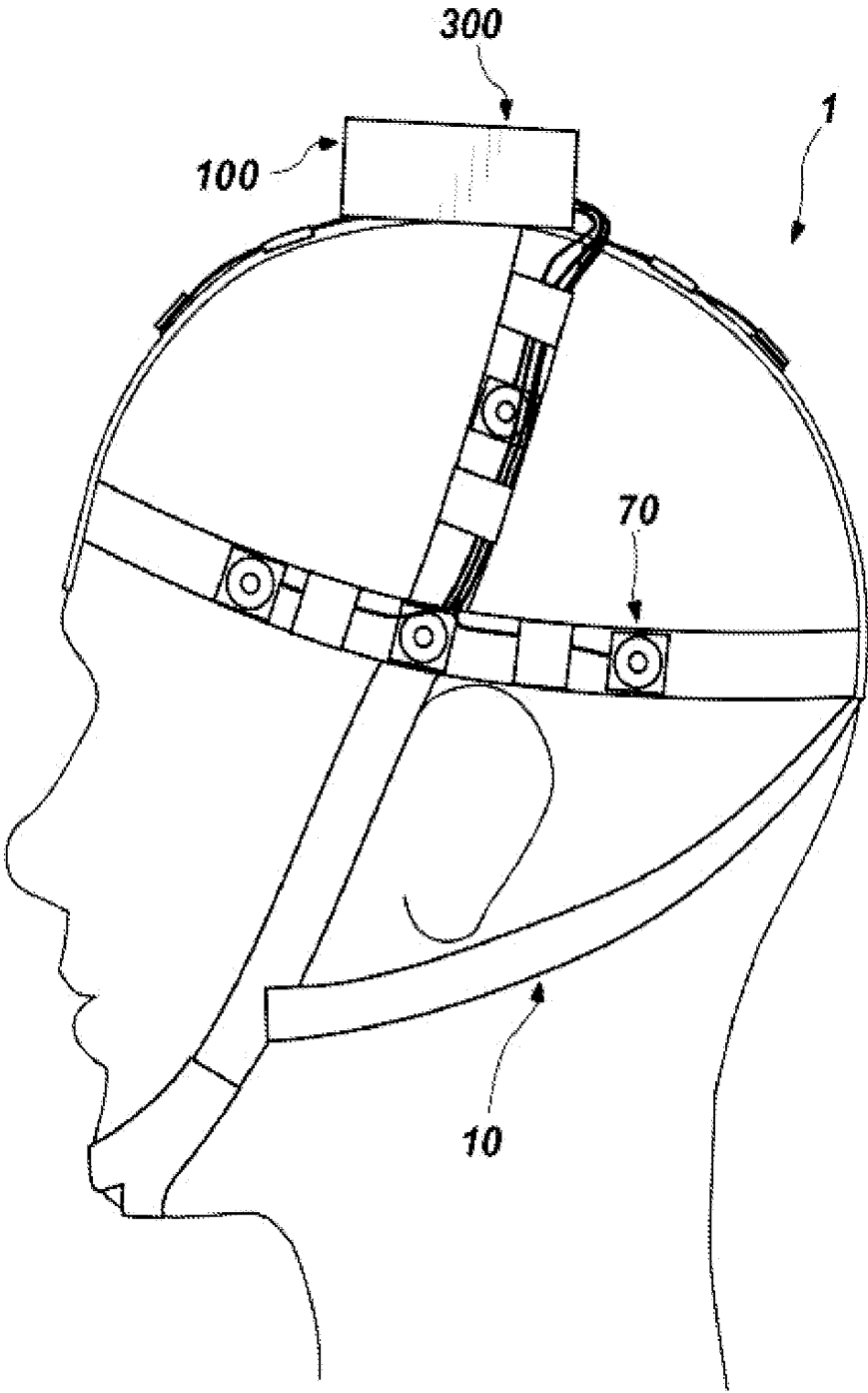

Figure 2

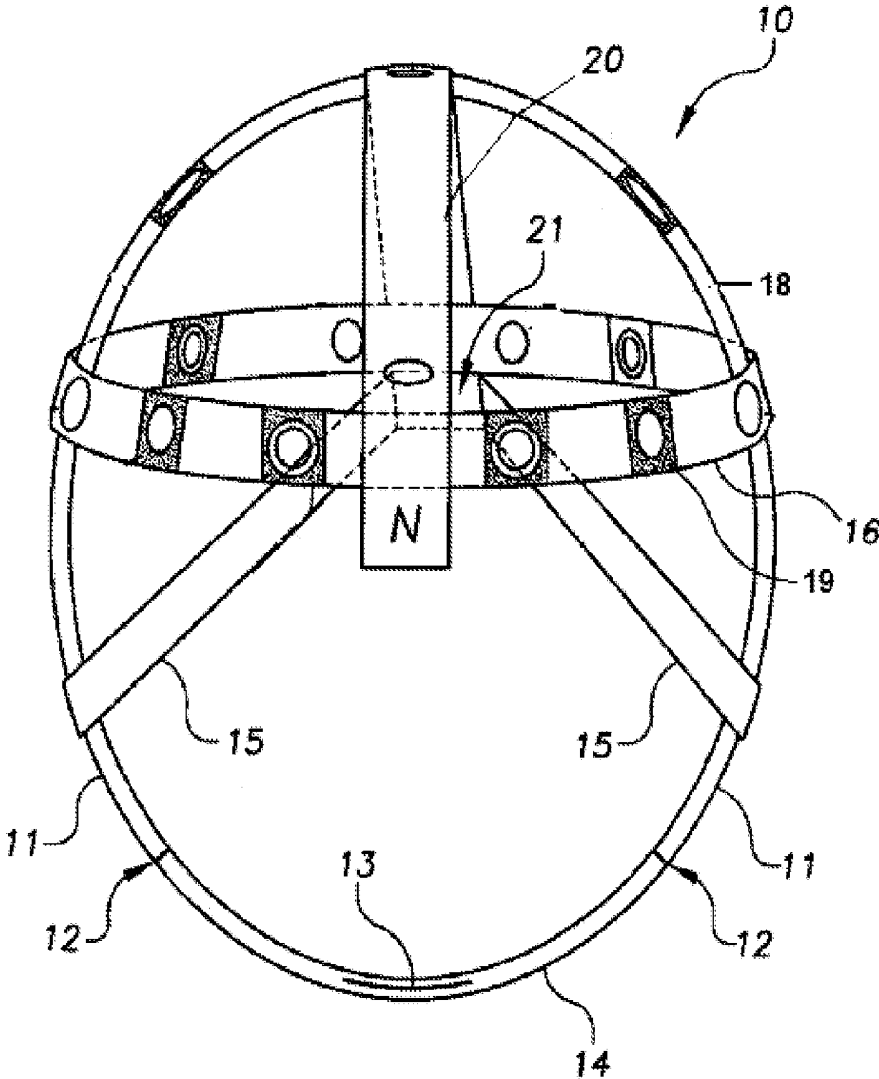

Figure 3

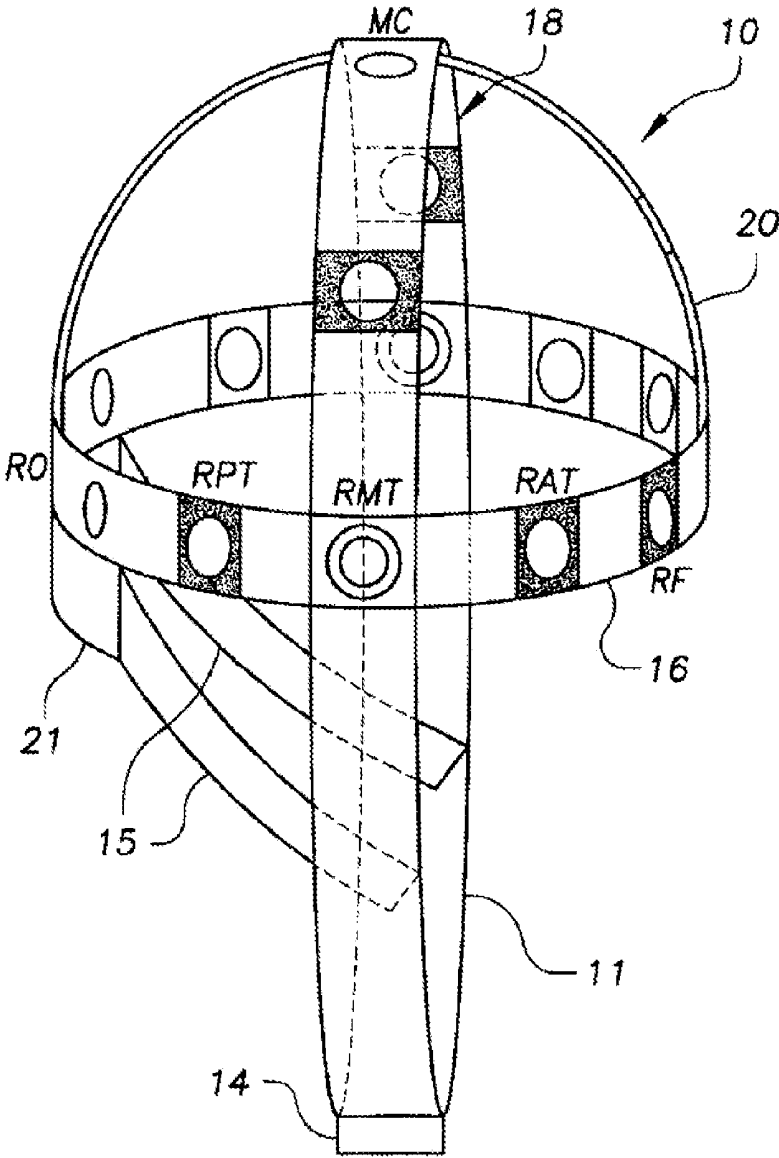

Figure 4

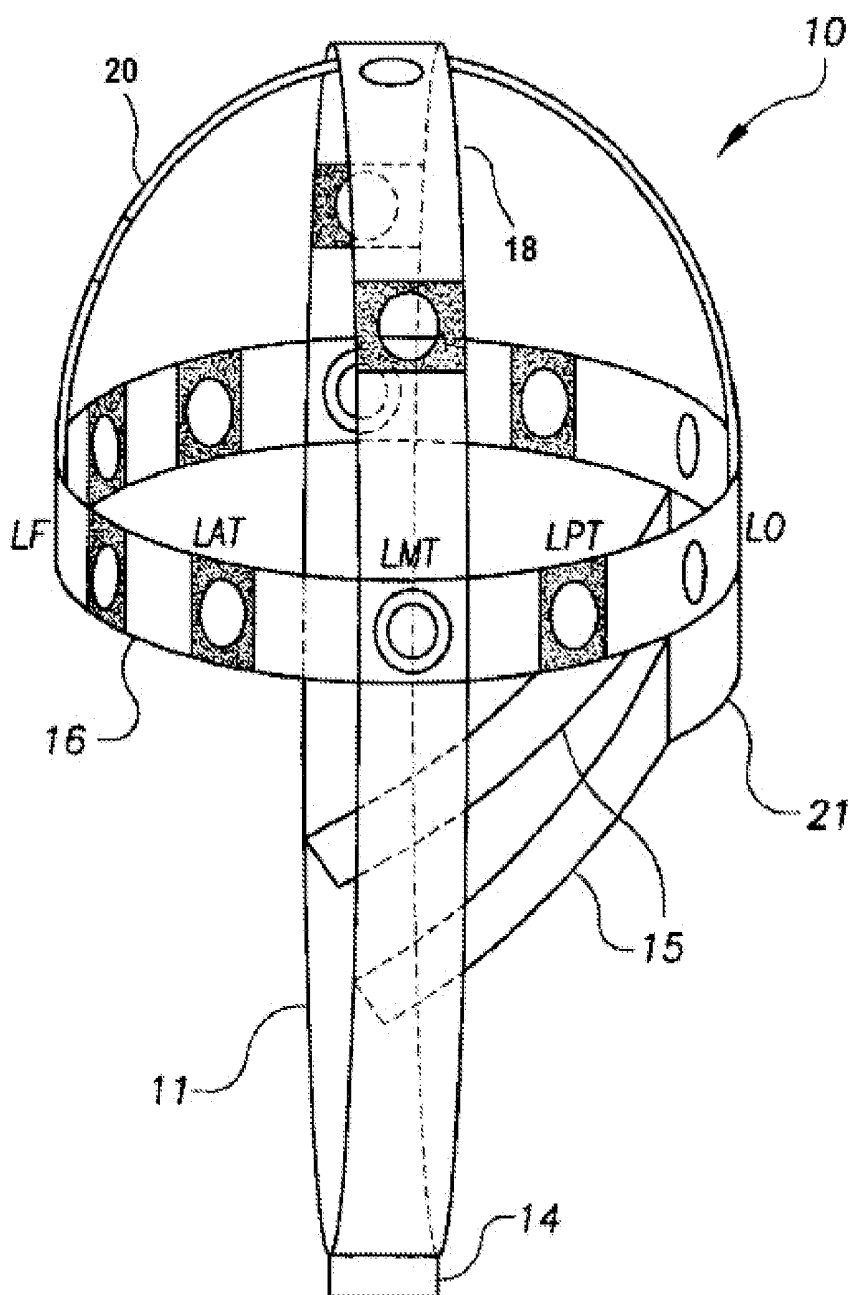

Figure 5

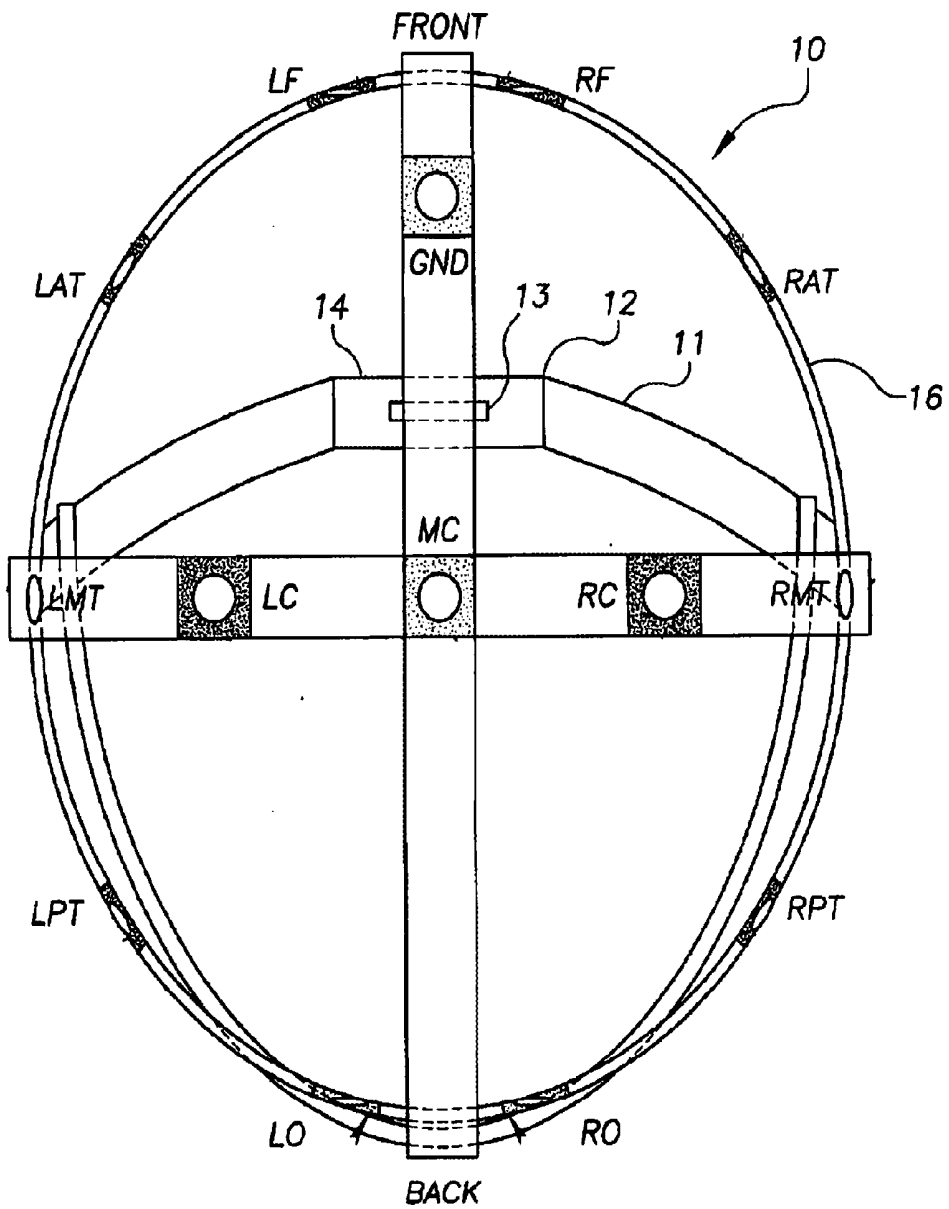

Figure 6

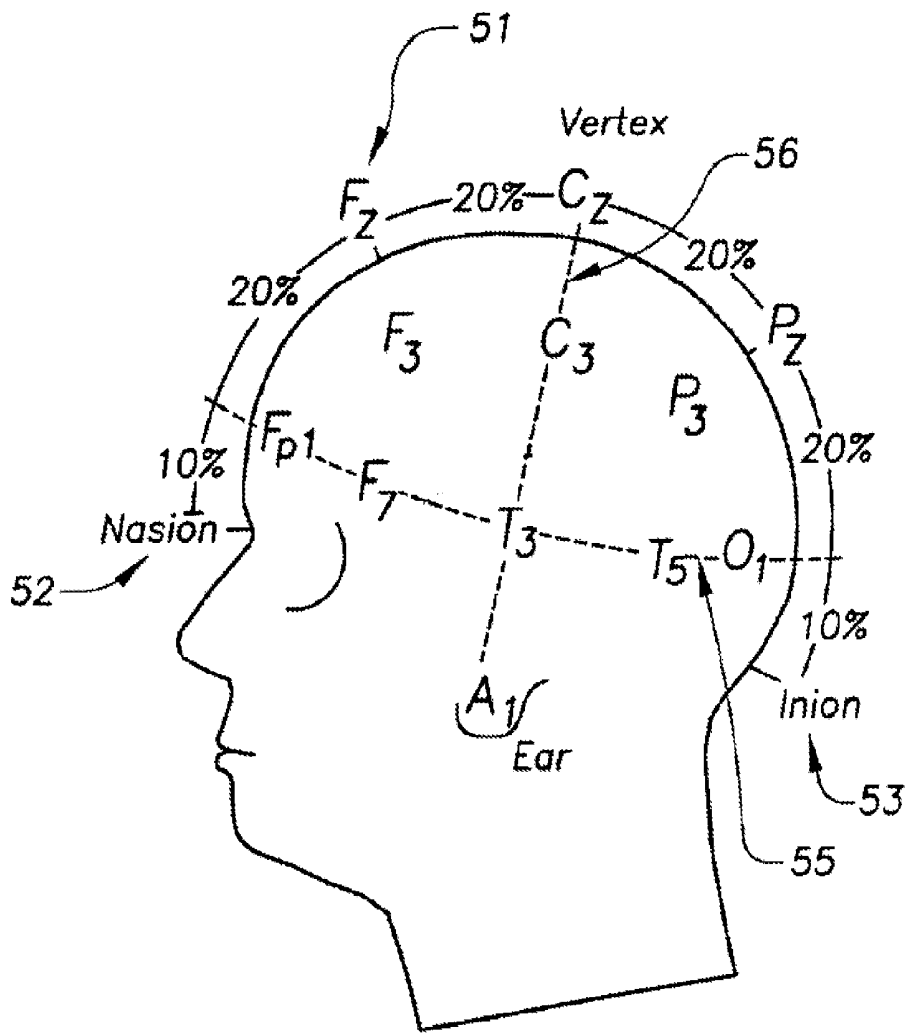

Figure 7

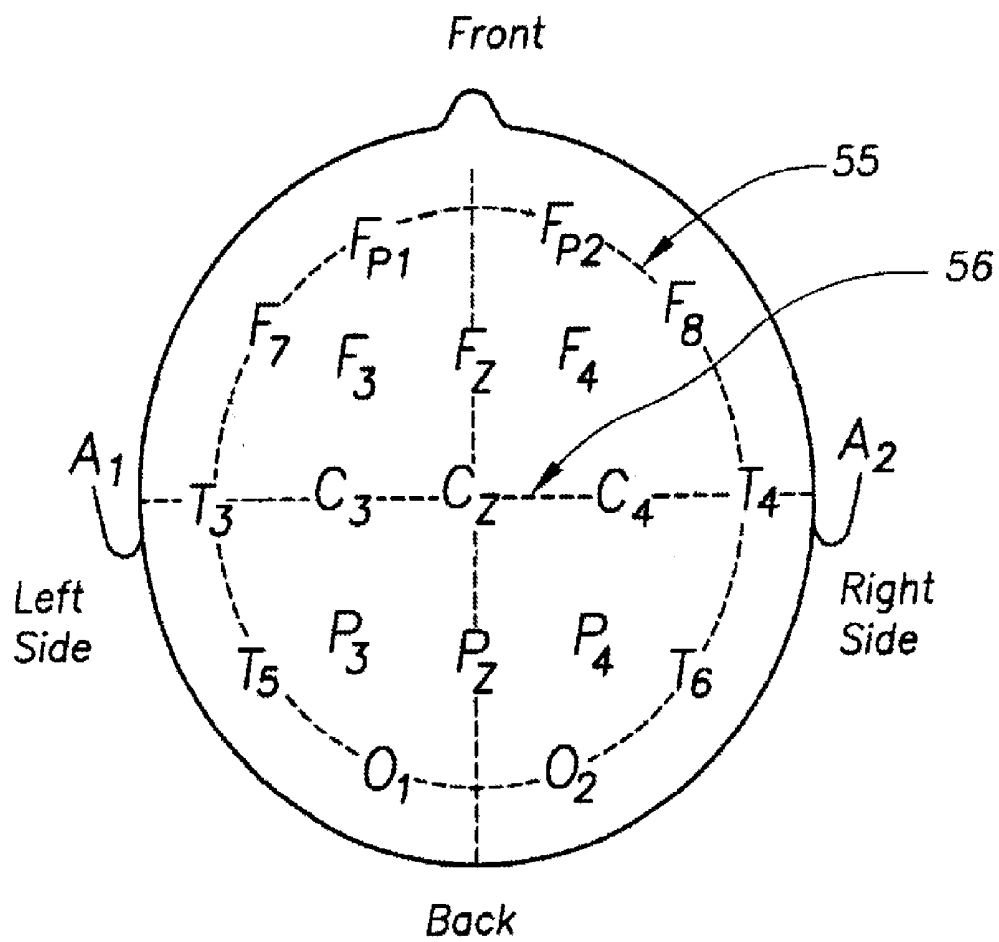

Figure 8

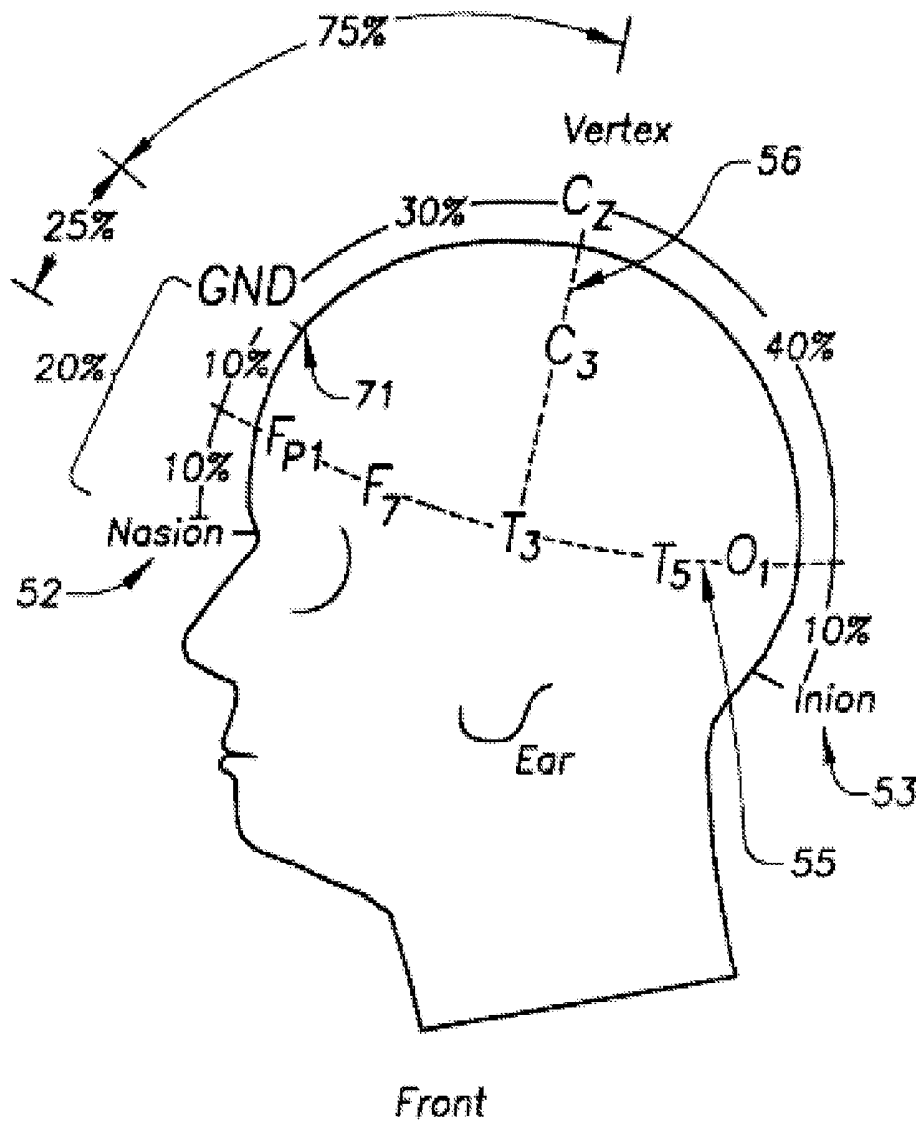

Figure 9

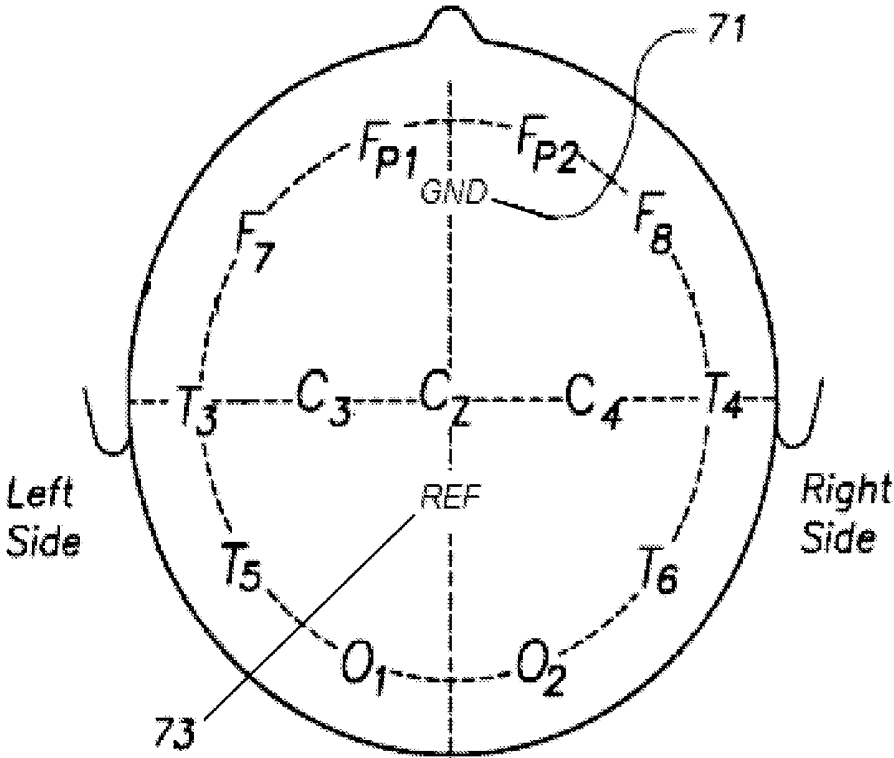

Figure 10

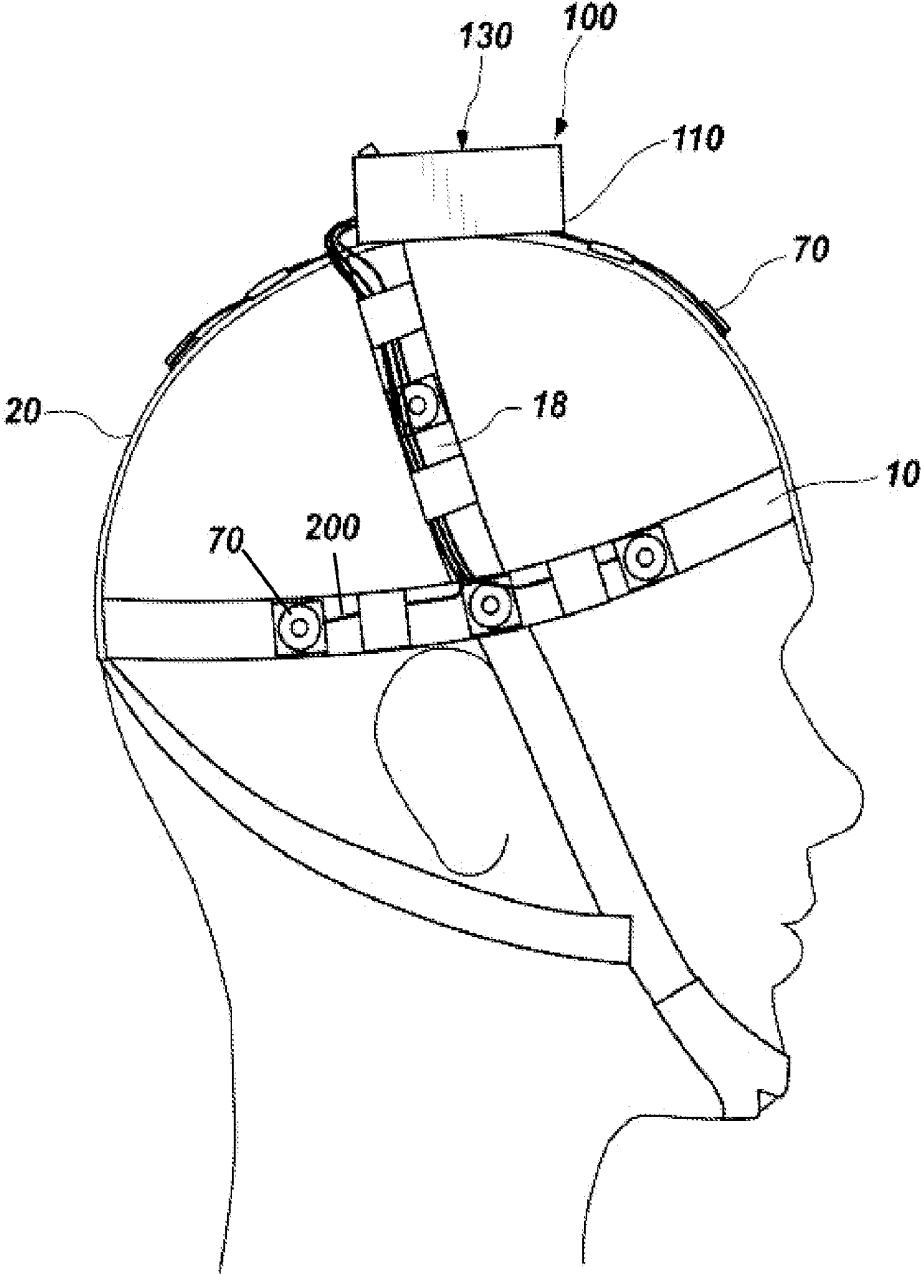

Figure 11

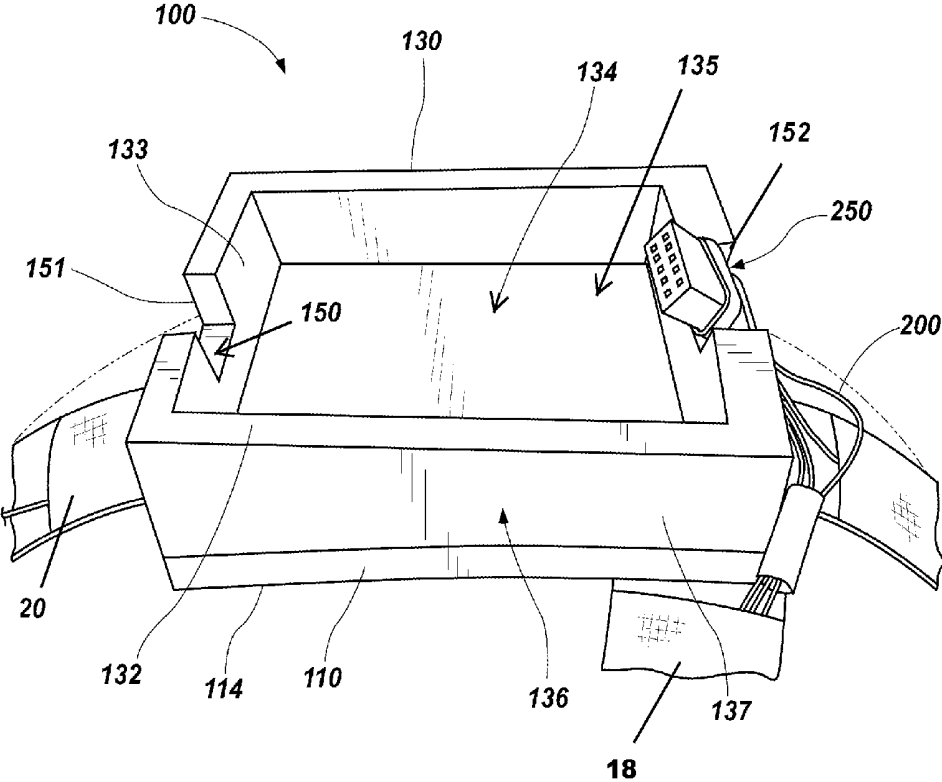

Figure 12

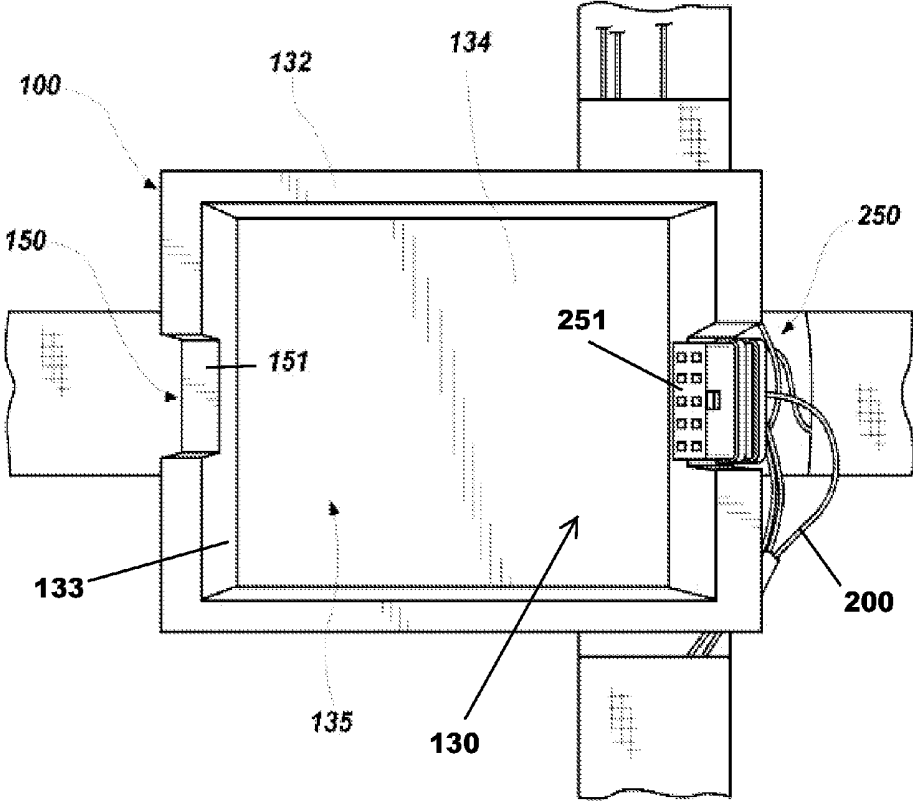

Figure 13

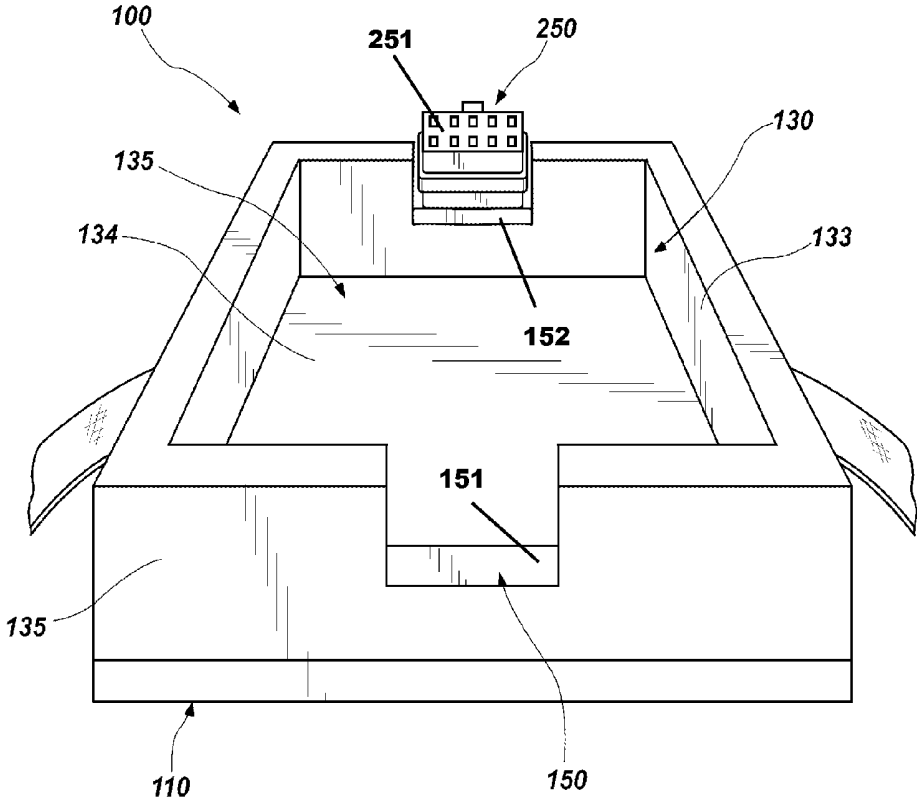

Figure 14

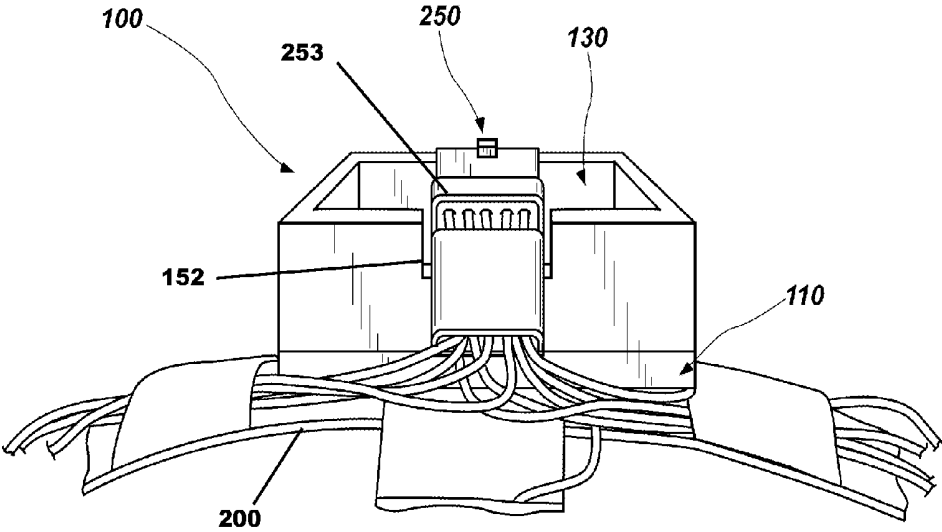

Figure 15

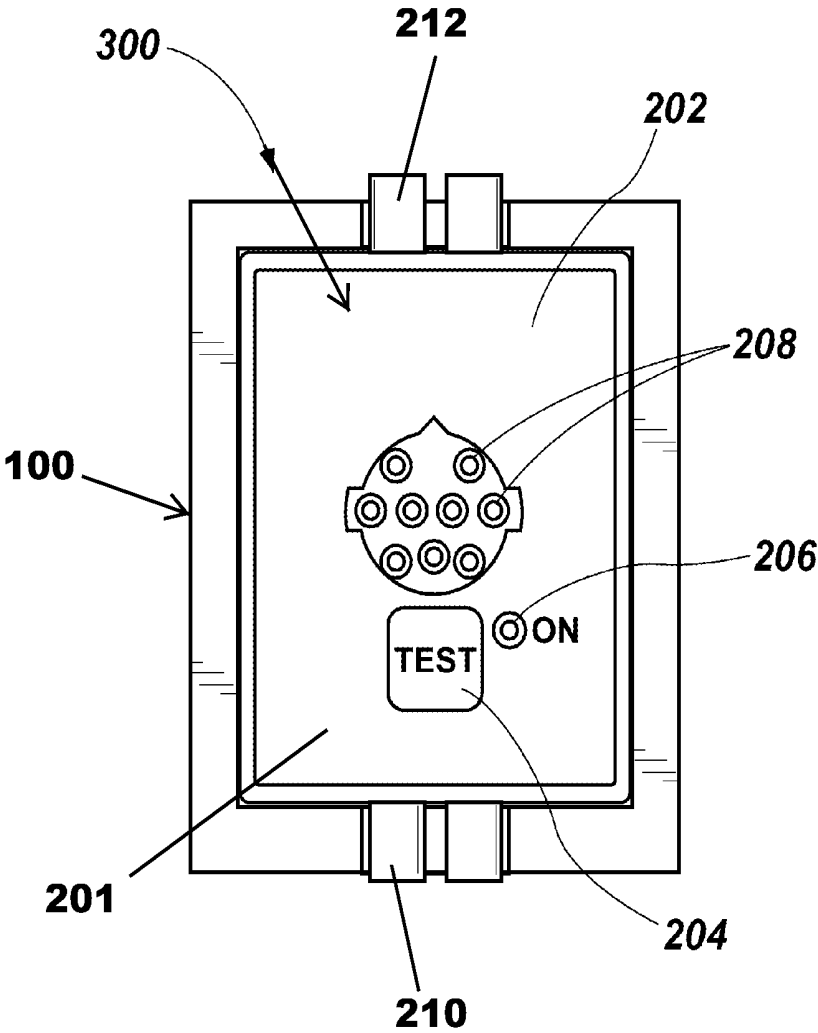

Figure 16

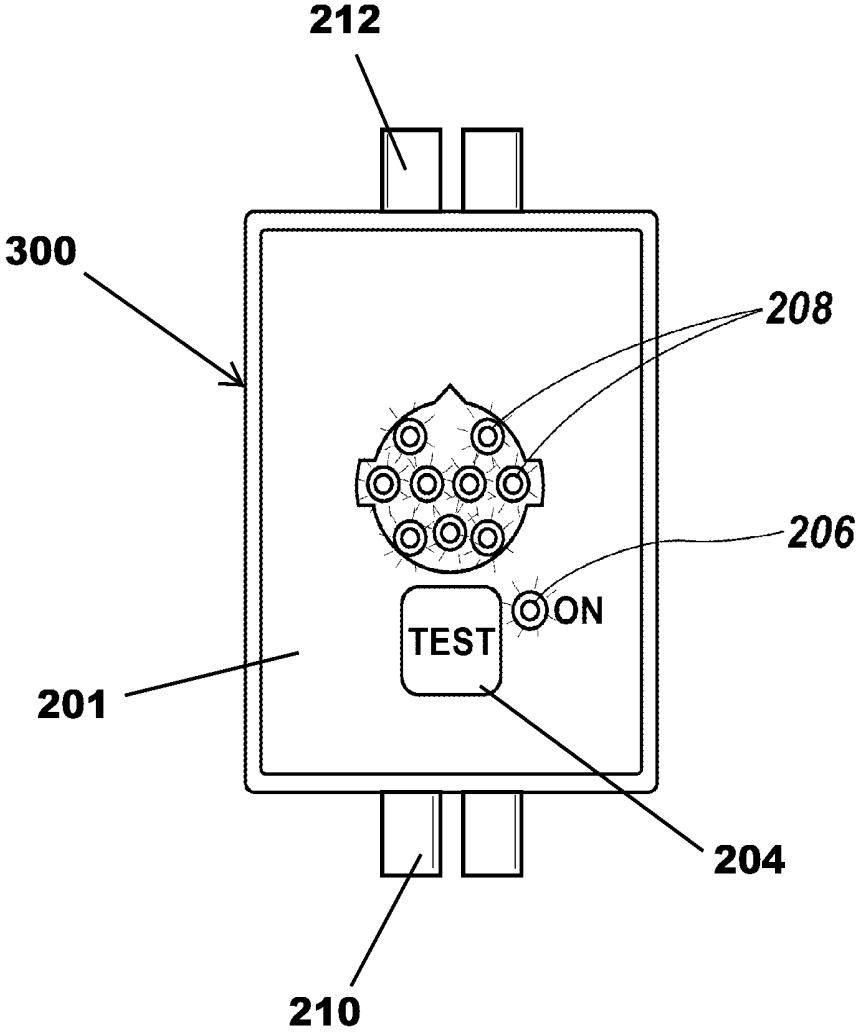

Figure 17

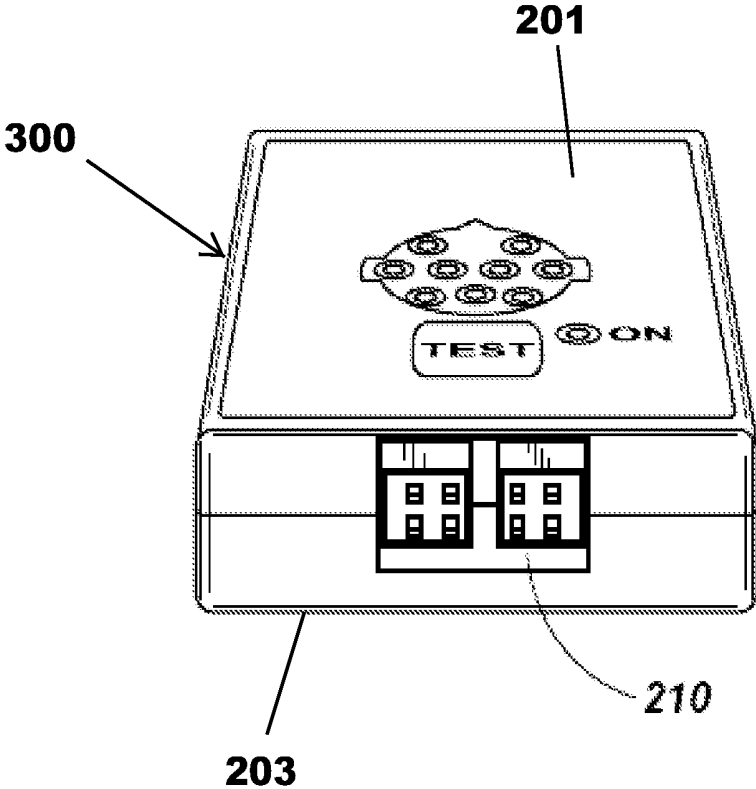

Figure 18

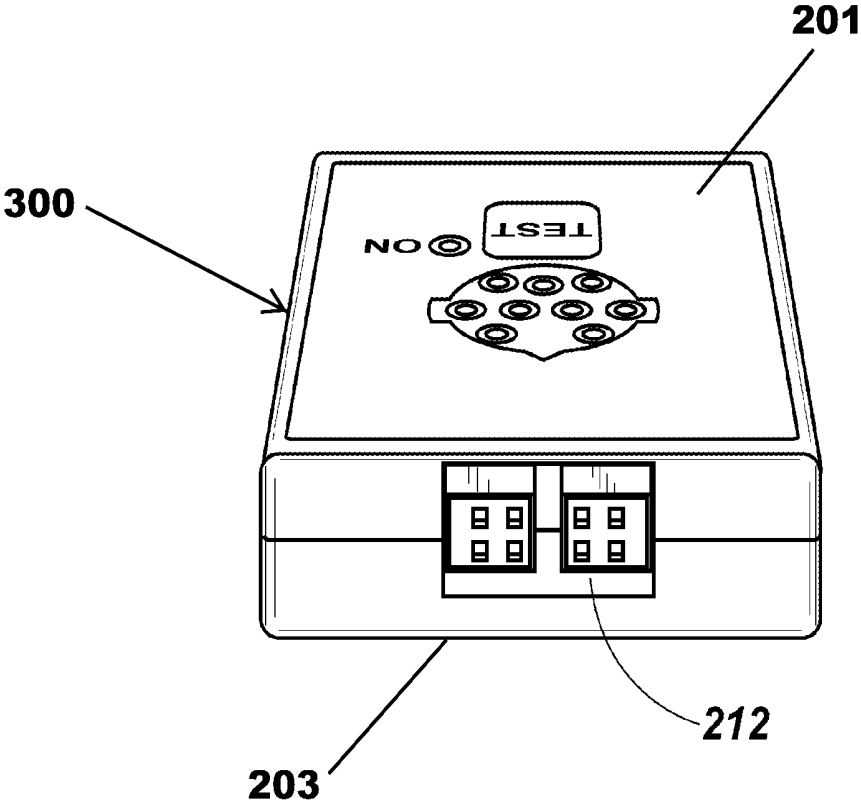

Figure 19

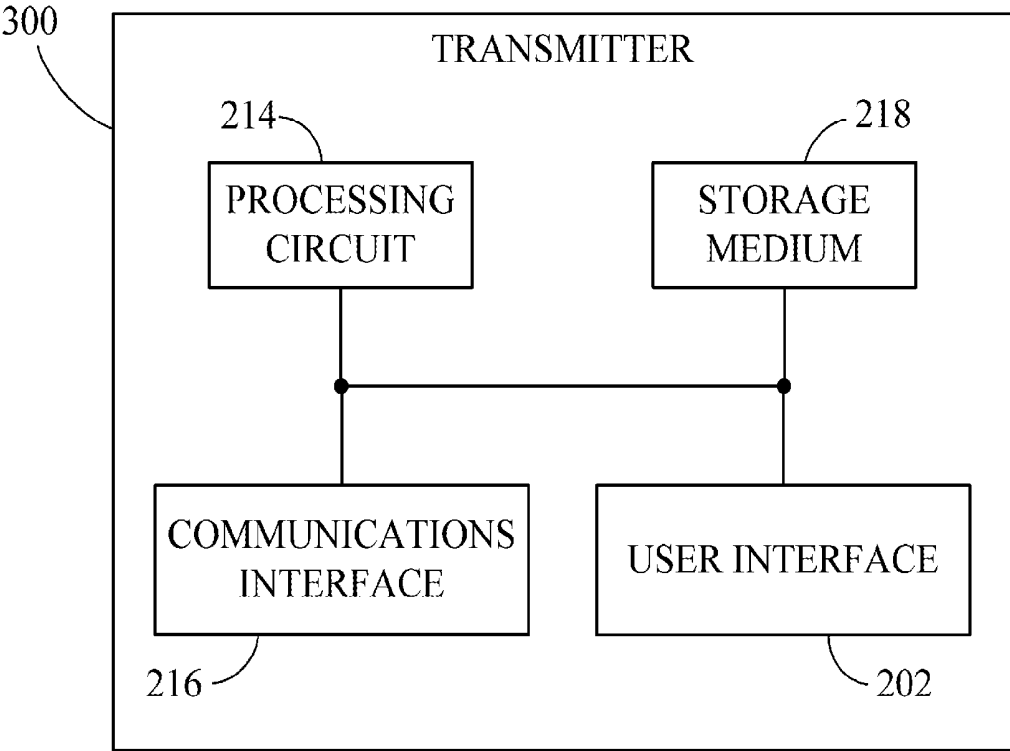

Figure 20

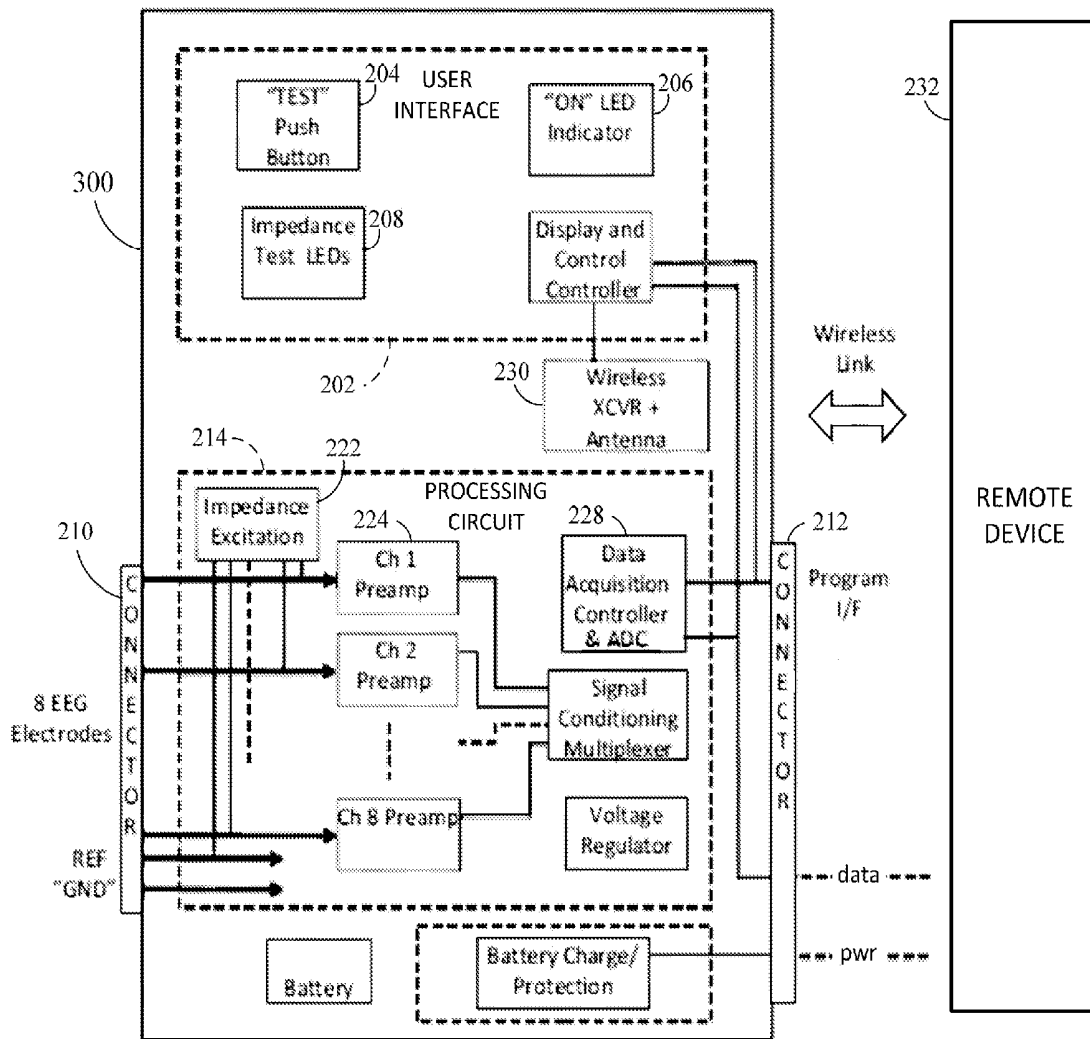

Figure 21

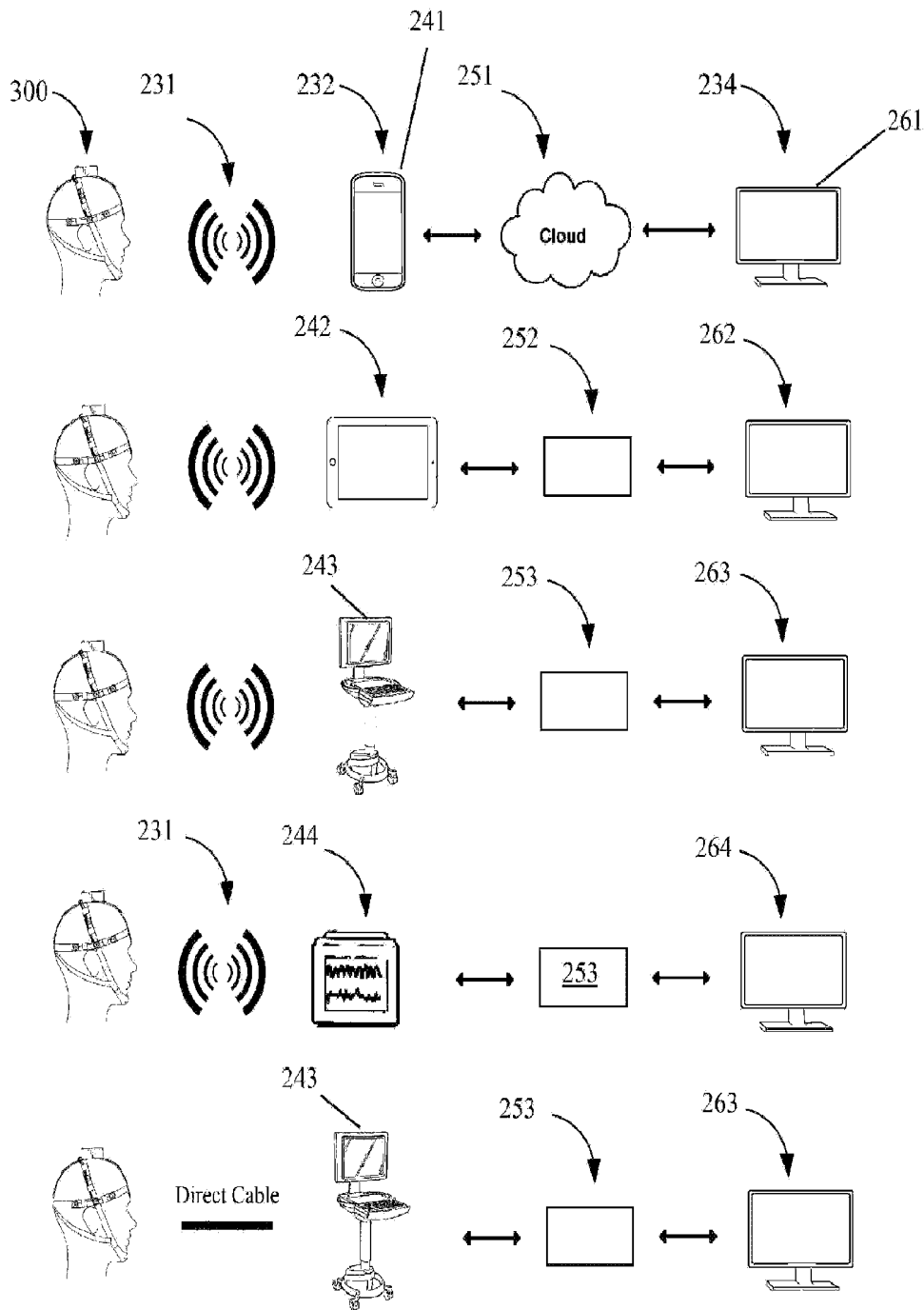

Figure 22

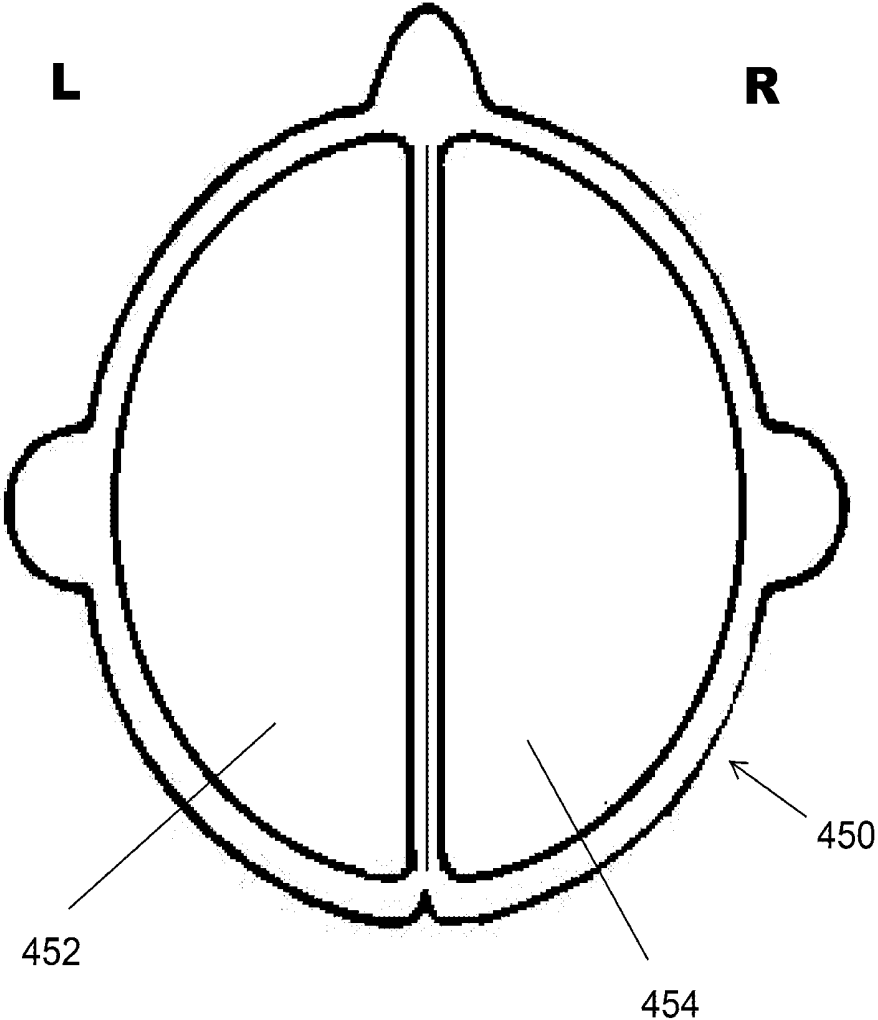

Figure 23

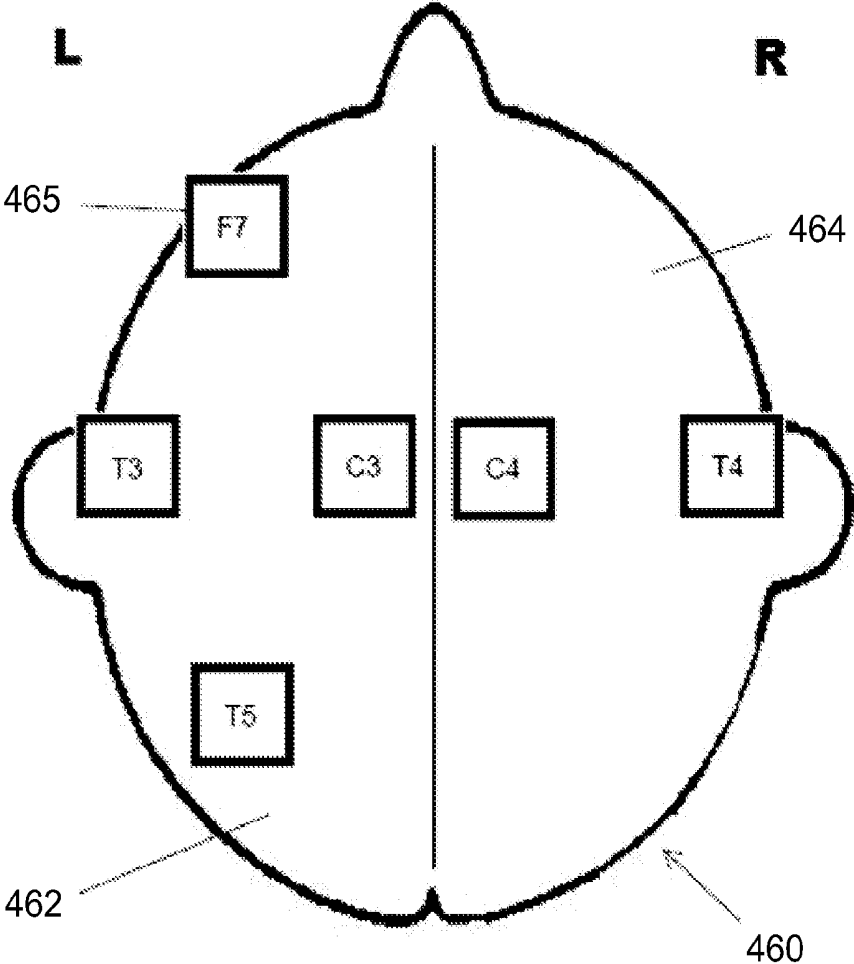

Figure 25

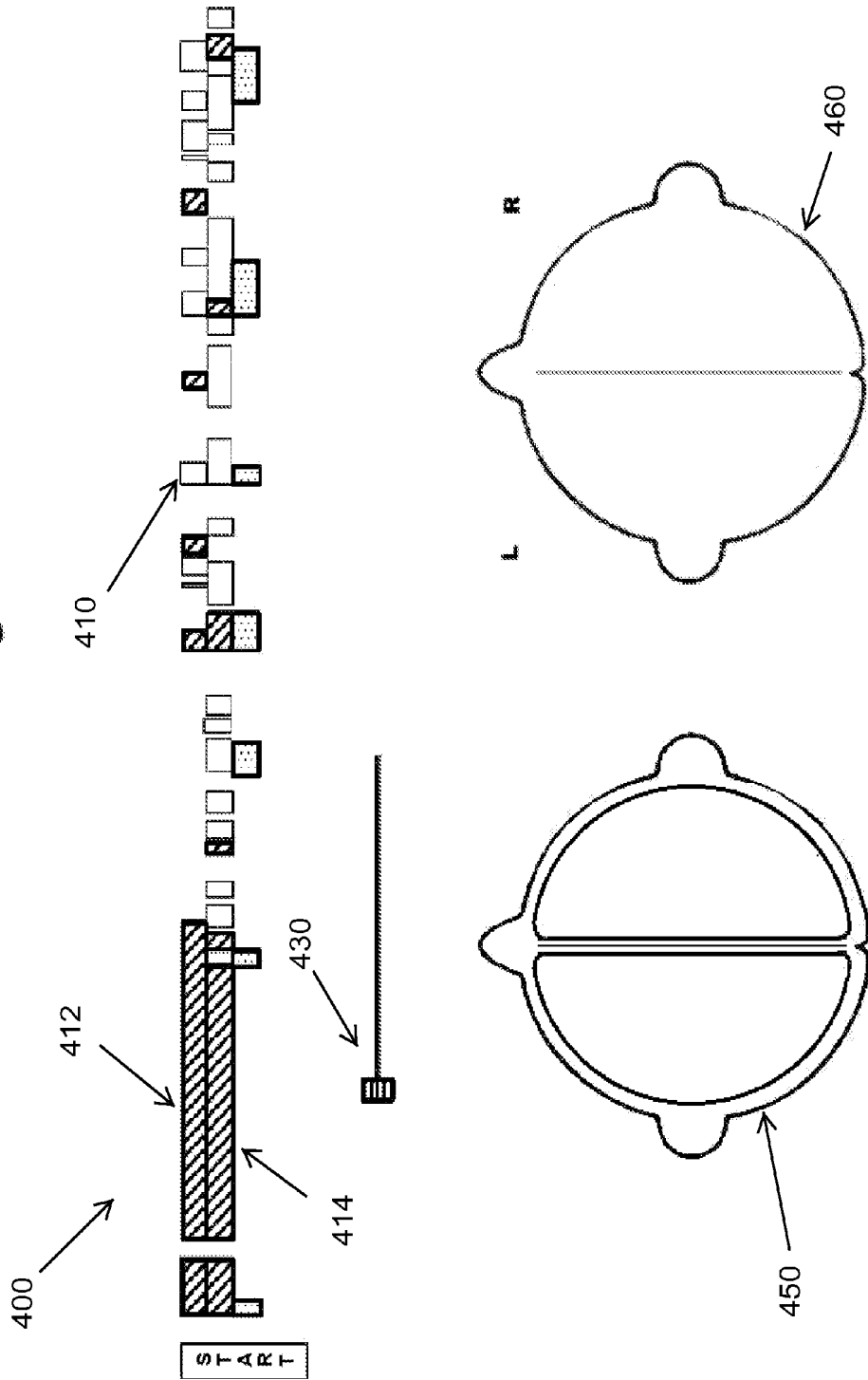
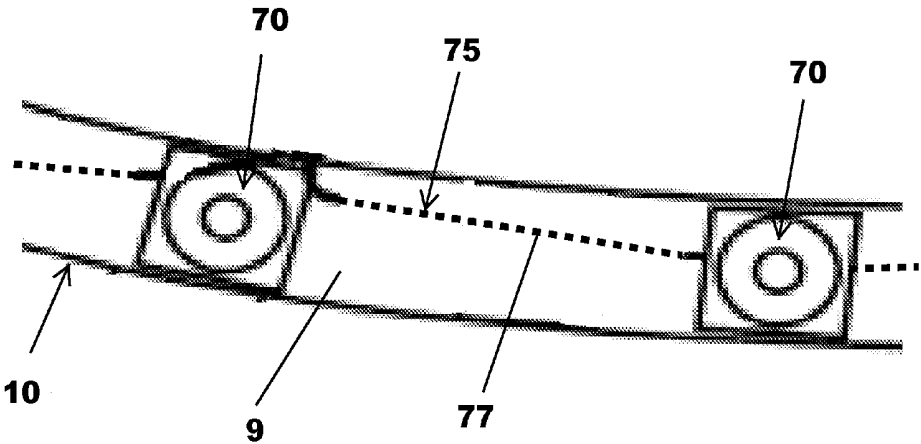

Figure 26



WIRELESS EEG UNIT

BACKGROUND

[0001] Electrical potentials are generated by ionic current flows within the neurons of the brain. Such current flows can be detected by electroencephalography (EEG). EEG devices record the brain's electrical activity and display it in the form of an electroencephalogram (EEG), which generally depicts waveforms of varying frequency and amplitude as measured in voltage. EEG waveforms are generally classified according to their frequency (standard frequency ranges termed alpha, beta, theta, and delta), amplitude, and shape, as well as by the sites on the scalp at which they are recorded.

[0002] An irregular brain wave pattern can be indicative of a particular brain pathology. Distinctive EEG patterns are seen, for example, in acquired brain injury (ABI), accelerated cerebral edema, expanding intracranial masses, and severe cerebral ischemia. Such patterns include encephalographic seizures, markedly slow frequencies, amplitude suppression, "burst suppression," and periodic epileptiform discharges (PEDS) (Jordan 2004, Khan et al 2005, Schneider 2005). While not specific for particular diagnoses, these patterns provide an early, sensitive and reliable warning of severe or worsening brain damage.

[0003] The use of EEG when brain injury is suspected is of particular importance because EEG can detect injuries at an early stage, before they progress to more serious conditions. For example, in moderate to severe traumatic ABI, such as from the blast of an explosion or a concussive impact, or in non-traumatic ABI from a stroke or hemorrhage, death or irreversible brain injury are most closely associated with "secondary progression" events that can be detected with EEG, including brain edema, enlarging hemorrhages, seizures, torn or occluded blood vessels, and brain herniation. In the context of acute traumatic brain injury (ATBI), EEG can provide an early warning of worsening brain damage and provide clues about the underlying disease process.

[0004] Conventional continuous EEG (CEEG) methods have changed little in decades, and are both inefficient and labor intensive. EEG is oftentimes not readily available, even in hospitals, and delays of hours may occur before an EEG procedure is performed and the results interpreted. Such delays can result in a patient not receiving appropriate treatment, resulting in preventable and sometimes irreversible harm to the patient. The complexity and time involved in applying electrodes to a patient's scalp using traditional EEG can contribute to such delays, as can the absence of a physician or a technician trained to interpret EEG results in a hospital.

[0005] There remains a need, therefore, for real-time, functional brain state assessment technology which can be performed in a variety of settings where it may be needed, for example in sports venues, emergency response situations, and battlefield settings.

SUMMARY

[0006] The present invention comprises a wireless EEG device that includes:

[0007] (a) a head strap for retaining a plurality of electrodes on the head of a subject, the head strap comprising at least a sagittal strap portion;

[0008] (b) a docking station attached to the sagittal strap portion at the crown of the subject's head, the docking station comprising:

[0009] a base formed from a material which is transparent to X-rays,

[0010] a receptacle supported by the base, and, optionally

[0011] a cover placed over the wireless transmitter; and

[0012] (c) a wireless transmitter in electrical communication with the plurality of electrodes for transmitting an electrical signal received by the electrodes from the subject's brain which is securely retained within the receptacle.

[0013] The base of the docking station is preferably formed from a foam material having a thickness of at least 1.3 centimeters, more preferably of between 2.5 and 6 centimeters. The base and receptacle can be integrally formed, preferably from a material that absorbs, scatters and/or reflects less than 20% of X-ray radiation received by the base and the receptacle, more preferably less than 10%, and even more preferably less than 1%. The plurality of electrodes, which can be needle electrodes, disc electrodes, and/or cup electrodes, are preferably placed in electrical communication with the wireless transmitter using non-ferromagnetic electrically conductive thread. The wireless EEG device can be used to perform EEG, and a CT scan or X-ray image can be further obtained without removing the strap and docking station from a subject's head.

[0014] In another embodiment, the present invention comprises an EEG device that includes:

[0015] (a) a head strap formed from an elastic material, the head strap comprising a plurality of head strap portions which extend across a plurality of EEG electrode positions on the head of a subject, the electrode positions being selected from the group consisting of Fp1, Fp2, F7, F3, Fz, F4, F8, A1, T3, Cz, C3, C4, T4, A2, T5, P3, Pz, P4, T6, O1, and O2;

[0016] (b) a plurality of electrodes attached to the head strap at the plurality of EEG electrode positions;

[0017] (c) a plurality of non-ferromagnetic electrically conductive threads, which can comprise copper or silver, each conductive thread being in electrical communication at a first end with one of the plurality of electrodes and at a second end with an electrical connector that can be further connected to a transmitter.

[0018] The conductive thread is preferably secured to the head strap by passing the conductive thread from an upper surface of the head strap to a lower surface and then from the lower surface to the upper surface in a repetitive manner along a longitudinal extent, thereby disposing the conductive thread in a sinusously curved manner along the extent of the head strap, in the manner of sewing. Each of the conductive threads preferably have a diameter of between 0.5 millimeters (mm) and 5 mm, and more preferably between 2 mm and 4 mm. At least a portion of one or more of the conductive threads are also preferably disposed in stitches having a length of between 0.5 mm and 10 mm, more preferably between 1 mm and 5 mm, and even more preferably between 2.5 mm and 3.5 mm. In addition, the conductive threads are each preferably surrounded by an electrically insulating material.

[0019] The transmitters used in the present invention are adapted for use with an EEG device and can include:

[0020] (a) a communications interface comprising an electrode interface communicatively coupled to a plurality of electrodes;

[0021] (b) a user interface including at least one electrode impedance indicator; and

[0022] (c) a processing circuit coupled with the communications interface and the user interface, the processing circuit adapted to:

[0023] receive a respective electrical signal from each of the plurality of electrodes;

[0024] measure an impedance associated with each electrode of the plurality of electrodes; and

[0025] visually display via the at least one electrode impedance indicator whether the impedance associated with each electrode is above or below a predetermined threshold.

[0026] In these transmitters, the communications interface can further comprise a wireless transceiver, and the processing circuit can be adapted to simultaneously transmit via the wireless transceiver the impedance associated with each electrode and an electrical signal received by each electrode from a subject's brain.

[0027] In an alternative embodiment, the transmitters used in the present invention can include:

[0028] (a) a communications interface comprising:

[0029] a wireless transceiver; and

[0030] an electrode interface communicatively coupled to a plurality of electrodes; and

[0031] (b) a processing circuit coupled with the communications interface and the user interface, the processing circuit adapted to:

[0032] measure an impedance associated with each electrode of the plurality of electrodes;

[0033] receive via the electrode interface a respective electrical signal by each electrode from a subject's brain; and

[0034] simultaneously transmit via the wireless transceiver the measured impedance associated with each electrode and the respective electrical signal by each electrode from a subject's brain.

[0035] The present invention also includes a method of evaluating the brain activity of a subject using an EEG. In this method, an EEG comprising waveforms generated by electrical activity within each of the two hemispheres of the brain of the subject is obtained. Such waveforms occur in predetermined patterns, and can be displayed as visually distinguishable indicia, such as indicia in different colors, in temporal order and in a linear fashion, thereby forming a temporal waveform record in graphical form. EEG data from the EEG is preferably processed in predetermined time segments, the time segments preferably being between 5 seconds and 20 seconds in length, and advantageously being 10 seconds in length. The waveform patterns for each hemisphere of the subject's brain are also preferably displayed separately. The predetermined indicia indicates a predetermined waveform pattern, such as suppression, slowing, burst-suppression, inter-hemisphere asymmetry, periodic epileptiform discharge, or seizure.

[0036] The method further includes playing a time indicator in the temporal waveform record, the time indicator designating a time point in the temporal waveform record. Preferably, waveform patterns of both hemispheres of the

subject's brain are displayed together in parallel. A graphical image having two adjacent predetermined display areas is then displayed. The indicia displayed in each display area correspond to the indicia in the temporal waveform record for a respective hemisphere of the subject's brain at the point in the temporal waveform record where the time indicator is displayed.

FIGURES

[0037] FIG. 1 is a left side elevation view of the present EEG device being worn by a subject.

[0038] FIG. 2 is a front elevation view of a head strap for use with the present EEG device.

[0039] FIG. 3 is the right side elevation view of the head strap of FIG. 2.

[0040] FIG. 4 is the left side elevation view of the head strap of FIG. 2.

[0041] FIG. 5 is a top plan view of the head strap of FIG. 2.

[0042] FIG. 6 is a left side elevation view of the positions of electrodes according to the International 10-20 System.

[0043] FIG. 7 is a top plan view of the positions of electrodes according to the International 10-20 System.

[0044] FIG. 8 is a left side elevation view of the positions of electrodes in an alternative embodiment of the present EEG device.

[0045] FIG. 9 is a top plan view of the positions of electrodes in the embodiment of FIG. 8.

[0046] FIG. 10 is a right side elevation view of the docking station of the present EEG device being worn by a subject.

[0047] FIG. 11 is a perspective view of the docking station of FIG. 10.

[0048] FIG. 12 is a top plan view of the docking station of FIG. 10.

[0049] FIG. 13 is front perspective view of the docking station of FIG. 10.

[0050] FIG. 14 is a rear elevation view of the docking station of FIG. 10.

[0051] FIG. 15 is a top plan view of the transmitter of the present EEG device.

[0052] FIG. 16 is a top plan view of the transmitter of FIG. 15 showing a power indicator and impedance indicators powered on.

[0053] FIG. 17 is a rear perspective view of the transmitter of FIG. 15.

[0054] FIG. 18 is a front perspective view of the transmitter of FIG. 15.

[0055] FIG. 19 is a block diagram of the transmitter of FIG. 15 in communication with a receiver.

[0056] FIG. 20 is a block diagram of at least some components of the transmitter of FIG. 19 in one embodiment.

[0057] FIG. 21 is a block diagram of some examples of network environments in which the transmitter of FIG. 15 can operate.

[0058] FIG. 22 is an illustration of a simplified user interface for reviewing EEG data.

[0059] FIG. 23 is an illustration of a user interface showing impedance data of the electrodes of an EEG device.

[0060] FIG. 24 is an illustration of another user interface for reviewing EEG data.

[0061] FIG. 25 is an illustration of a preferred user interface for reviewing EEG data.

[0062] FIG. 26 is a top plan view of a head strap having electrodes electrically connected with conductive thread.

DESCRIPTION

[0063] Definitions

[0064] As used herein, the following terms and variations thereof have the meanings given below, unless a different meaning is clearly intended by the context in which such term is used.

[0065] “Base” refers to the bottom support of a component or device.

[0066] “Cloth” refers to a flexible material formed by weaving, knitting, pressing, or felting natural or synthetic fibers, and includes similar materials formed by polymerization or casting.

[0067] “Cloud” refers to a network in which computing resources (hardware and/or software) are delivered as a service over a network such as the internet.

[0068] “Coronal” refers to an orientation that is within or parallel to a subject’s coronal plane, which is a hypothetical vertical plane that divides a subject’s body (or a portion thereof) into ventral (front) and dorsal (back) sections, preferably of approximately equal sizes (by width or volume).

[0069] “Crown” refers to the top portion of a subject’s head when the subject is standing upright, approximately where the sagittal and coronal planes of the subject intersect.

[0070] “CT scan” and “CAT scan” refer to X-ray computed tomography, which is a medical imaging procedure that utilizes computer-processed X-rays to produce tomographic images (generally cross-sectional images) of specific areas of a subject’s body.

[0071] “Docking station” refers to a hardware frame which provides support and also provides one or more electrical connections.

[0072] “EEG” refers to electroencephalography, i.e. the recording of electrical activity at a subject’s scalp, in order to measure voltage fluctuations resulting from ionic current flows within the neurons of the subject’s brain.

[0073] “EEG device” refers to a device for performing EEG.

[0074] “Elastic limit,” also called the yield point, refers to the stress at which an elastic material ceases to deform elastically and will no longer return to its original shape when the applied stress is removed.

[0075] “Ferromagnetic” refers to a characteristic of substances such as iron, nickel, or cobalt and various alloys that are able to form permanent magnets (i.e., they remain magnetized after an external field is removed) under the conditions in which the present invention is used. “Non-ferromagnetic” refers to materials which are not ferromagnetic.

[0076] “Impedance” refers to the opposition to flow of alternating current through a circuit.

[0077] “Jack” refers to an electrical connector comprising a “female” electrical contact or socket, i.e. which receives another electrical connector, and is generally the more “fixed” connector of a connector pair comprising a jack and a plug.

[0078] “Nonconductive” refers to a material which does not conduct electricity under the conditions in which the present device is used.

[0079] “Pedestal” refers to a base or supporting structure which supports another component of the present device.

[0080] “Plug” refers to an electrical connector comprising a “male” electrical contact or pin, i.e. which is inserted into or onto another electrical connector, and is generally the more movable (less fixed) connector of a connector pair comprising a jack and a plug.

[0081] “Programming” refers to instructions, instruction sets, data, code, code segments, program code, programs, subprograms, software modules, applications, software applications, software packages, routines, subroutines, objects, executables, threads of execution, procedures, functions, and similar technology, whether referred to as software, firmware, middleware, microcode, hardware description language, or otherwise.

[0082] “Receptacle” refers to a component of the present device having a space of sufficient size and volume to receive some or all of another component or device and thereby retain the other component or device in the receptacle.

[0083] “Sagittal” refers to an orientation that is within or parallel to a subject’s sagittal plane, i.e. a hypothetical vertical plane which passes from ventral (front) to dorsal (back) of a subject’s body, dividing the body into approximately equally sized right and left halves.

[0084] “Scalp” refers to the skin covering the head.

[0085] “Sew” refers to the attachment of a thread or other length of material to a cloth by passing the thread through one side of the cloth and then back through the other side a plurality of times.

[0086] “Strap” refers to a length of flexible material used to secure another component to a particular location.

[0087] “Thread” refers to a strand or length of material with a diameter or thickness significantly less than its length, and generally less than 5 millimeters in diameter.

[0088] “Transparent” refers to a material which allows a predetermined frequency of electromagnetic radiation to pass through it while absorbing, scattering and/or reflecting less than 20% of the radiation, more preferably less than 10% of such radiation, and even more preferably less than 1%.

[0089] “Transverse” refers to an orientation that is within or parallel to a hypothetical horizontal plane that divides a subject’s body into superior (upper) and inferior (lower) parts, and is generally perpendicular with respect to the sagittal and/or coronal planes of the subject.

[0090] “Visually coded” refers to the use of a predetermined set of visually distinguishable indicia or signals (i.e., two or more visually distinguishable colors, patterns, shadings, and/or other visual referents). Visually coded displays allow a user to distinguish between a first visual signal and a second visual signal on the display, such as one or more areas on a display having a first color and one or more areas having a second color on the display.

[0091] “X-ray” refers to a form of electromagnetic radiation having a wavelength in the range of 0.01 to 10 nanometers.

[0092] The term “comprise” and variations of the term, such as “comprising” and “comprises,” are not intended to exclude other additives, components, integers or steps. The terms “a,” “an,” and “the” and similar referents used herein are to be construed to cover both the singular and the plural unless their usage in context indicates otherwise.

EEG Device

[0093] As shown in FIG. 1, the present EEG device **1** generally comprises a head strap **10** for retaining electrodes **70**, a docking station **100**, and a wireless EEG transmitter **300**. Electrodes **70** are disposed on the head strap **10**, and are used to receive electrical signals from the brain of a subject.

[0094] Head Strap

[0095] As shown in FIGS. 1-9, the head strap **10** can be formed from a plurality of head strap portions. These gener-

ally include a transverse strap portion 16, a coronal strap portion 18, and a sagittal strap portion 20. The sagittal strap portion 20 is adapted to be placed approximately within the sagittal plane of the subject's head from a front end on the subject's forehead to a rear end at the back of the subject's head. The coronal strap portion 18 is placed on the subject's head in an orientation that is generally parallel to the coronal plane of the subject's body, although the coronal strap portion 18 or parts of it may deviate from a parallel orientation in order to appropriately place electrodes carried by the coronal strap portion 18, conform to the contours of the subject's head, and better secure the head strap 10. The transverse strap portion 16 is placed on the subject's head in an orientation that is generally parallel to a transverse plane, though deviations to such an orientation likewise occur in order to appropriately place electrodes carried by the coronal strap portion 18 and conform to the contours of the subject's head, as described below. Deviations in the orientation of the strap portion may range from 10°-20° to up to 45°.

[0096] The head strap 10 can be secured to a subject in various ways known to the art, such as with fasteners attached to one or both lower ends of jaw straps 11, which can be opposite ends of a strap forming the coronal strap portion 18. In the embodiment shown in FIG. 2, a fastener strap portion 14 of one of the jaw straps 11 attaches to a fastener strap portion 14 of the other jaw strap 11 using a pair of mated connectors, in particular hook and loop fasteners (such as VELCRO brand fastener strips). The fastener strap portion 14 includes a slit 13 through the length of the chin strap 14, in order to better anchor the strap to the patient's chin.

[0097] Bias straps 15 can also be added to the head strap 10 to further secure it in place. A preferred construction for the bias straps 15 connects a left bias strap and a right bias strap to a tab 21 of the head strap 10 which extends beyond the transverse strap portion 16. The bias straps 15 are each preferably removably connected to a respective jaw strap 11 with a fastener such as a hook and loop fastener.

[0098] The electrodes 70 of the head strap can be placed according to the standard 10-20 electrode placement system for locating EEG electrodes. In the standard 10-20 system, 21 electrodes are placed on a subject's head. These positions are commonly labeled Fp1, Fp2, F7, F3, Fz, F4, F8, A1, T3, Cz, C3, C4, T4, A2, T5, P3, Pz, P4, T6, O1, and O2, and are shown in FIGS. 6 and 7. In an alternative embodiment of the head strap 10 shown in FIGS. 8 and 9, the strap contains no openings for the F3/F4 pair of electrodes or the P3/P4 pair of electrodes, and the openings for the Fz and Pz electrodes are eliminated (electrode locations A1 and A2 frequently generate artifacts and so can also be eliminated when not doing referential recordings). In this embodiment, the head strap 10 has an opening geometry consisting essentially of thirteen openings 19 located according to the International 10-20 System specification for positioning electrodes at points Fp1, Fp2, F7, F8, T3, T4, Cz, C3, C4, T5, T6, O1, and O2, and a fourteenth opening for the ground 71. As shown in FIG. 8, the ground 71 is positioned 25% of the distance from the line 55 which circumscribes the subject's head (approximately in a transverse plane) toward the line 56 which the vertically traverses the subject's head (approximately in a coronal plane), or if measured with reference to the standard skull points of the nasion 52 and inion 53, this location for the ground is approximately 20% of the distance from the nasion 52 to the inion 53. This position of the ground can be varied by approximately half a centimeter in any direction and still

achieve the desired result. In addition to the ground 71, which provides grounding of the electrodes to minimize the 60 cycle ambient current interference, a reference electrode (REF) 73 is also preferably provided as a common input for a differential amplifier. In a further alternative, the Fz and Pz electrodes can be included in the head strap 10 in the positions dictated by the standard International 10-20 System.

[0099] The head strap 10 can be positioned on a subject in any position including supine, sitting, or erect. In a preferred embodiment, the head strap 10 is provided with indicia proximate to the electrode openings 19 in the strap portions in order to guide the placement of the electrodes 70 on the subject's scalp. FIGS. 3-5 include the electrode indicia MC, RC, LC, LO, RO, LPT, RPT, LMT, RMT, LAT, RAT, LF, RF and Gnd, with an "L" prefix being used for left positions and "R" for right positions.

[0100] The head strap 10 is preferably made from an elastic material, in particular an elastic cloth, in order to secure the head strap 10 to the head of a subject as well as to secure the electrodes 70 in the proper position. In this case the head strap 10 is preferably sized such that the sagittal strap portion 20 and the transverse strap portion 16, prior to being stretched, have a diameter which is less than the diameter of the head of a subject to be fitted with the head strap 10. The diameter of the subject's head should be within the elastic limit of the material forming the sagittal strap portion 20 and the transverse strap portion 16, so that the head strap 10 can be stretched to fit comfortably over the subject's head and then to contract so as to hold the head strap 10 in a predetermined position by a friction fit.

[0101] Electrodes

[0102] Any of a variety of electrodes known for use with EEG can be used with the present device 1. For example, the electrodes can be needle electrodes or disc (cup) electrodes. Needle electrodes comprise a needle made of metal or other conductive material, preferably having an impedance of less than 5 ohms. The needle has a pointed end for insertion into the scalp of a subject undergoing EEG and a second end for attachment to a conductive wire, conductive thread, or other electrical connection. Needle electrodes can be attached to a wire or conductive thread directly by soldering, or can be connected by other means, such as to a pin connector which then places the needle into electrical communication with the wire or conductive thread. Exemplative embodiments of needle electrodes can be 7 mm or 13 mm in length, for example. Preferably, a cover is provided for the sharp (pointed) distal end of a needle electrode in order to avoid needle stick injuries.

[0103] Needle electrodes have been used in EEG because of their relatively low impedance compared to some other electrode types. They have the disadvantage however of requiring that the subject's skin be pierced by the electrode. Disc electrodes avoid such issues, as they do not require skin abrasion. If the present device is to be used together with MRI imaging, local heating of the needle electrodes may also occur, in which case disc electrodes are preferred.

[0104] Disc and cup electrodes can be made from tin, silver, gold, surgical steel, or other electrically conductive materials. They typically have a diameter in the range of 4-10 mm. Disc and cup electrodes can be classified as being either dry electrodes or wet electrodes, depending on the presence of an electrolyte on the surface attached to the skin. Dry electrodes are generally attached to a skin surface mechanically, such as by means of pressure applied by an elastic cloth, as used in the

present head strap **10**. A wet electrode can be attached to the skin using a conductive liquid, hydrogel or solid gel, e.g. electrolyte gel, to improve the electrical conductivity between the recording (skin) surface and the electrode sensing element. Typical components of a conductive liquid or gel include electrolytes or salts, such as sodium chloride (NaCl) or potassium chloride (KCl), which provide the ionic conductivity.

[0105] In one embodiment, a disc electrode for use with the present device **1** can comprise a planar substrate made from a non-conducting material, such as a plastic film, a conductive electrode layer, and an adhesive layer surrounding the conductive electrode layer. The conductive layer can be, for example, silver (Ag), silver/silver chloride (Ag/AgCl), copper (Cu), or carbon (C). An example of a disc electrode for use with the present EEG headgear is a disposable conductive plastic electrode made by Ives EEG Solutions, Inc. (Newburyport, Mass., USA). One advantage of this electrode is that it is compatible with CT scanning. Another exemplary disc electrode is a RINGTRODE electrode (available from Multi Bio Sensors Inc., El Paso, Tex.), comprising a hard plastic disc with a silver/silver chloride (Ag/AgCl) sensor. Disc and cup electrodes can be attached to the head strap **10** by being embedded or sewn into the fabric or other substrate of the head strap, or by other means.

[0106] Conductive Thread

[0107] Signals from an electrode are typically transmitted to an EEG device using standard metal wires, and such wires can be used with the present device **1**. External wires, however, can become tangled, or can snag a protruding feature of something near the present device **1** and become disconnected, which can be a particular problem in less-controlled settings outside of a hospital. Therefore, in a preferred embodiment, an electrical connection between the electrodes **70** of the present device **1** and the wireless transmitter **300** is preferably accomplished with a conductive thread **75** integrated directly into the head strap **10**.

[0108] Conductive thread is a thin, electrically conductive strand of material, typically having a diameter in the range of between about 0.5 millimeters (mm) and 5 mm, preferably from 2 mm to 4 mm in diameter. In some embodiments, the thread can comprise a non-conductive or less conductive substrate which is either coated or embedded with electrically conductive elements, often carbon, nickel, copper, gold, silver, or titanium. Substrates typically include cotton, polyester, or nylon. Preferably, conductive threads used with the present device **1** are sterilizable, such as with ethylene oxide.

[0109] The conductive threads **75** used in the present EEG headgear preferably comprise a non-ferromagnetic material, such as copper, silver, or tungsten. In this way, a patient wearing the EEG headgear can undergo testing with an MRI or CT scan device without needing to remove the present headgear. This is a particular advantage when the electrodes used with the present headgear are needle electrodes, since removal of the electrodes from the patient's skin in order to undergo an MRI or CT scan procedure would be both inconvenient and uncomfortable. The conductive thread is also preferably surrounded (wrapped) by an electrically insulating material, so that adjacent threads **75** or threads that cross each other on the head strap **10** do not electrically interfere with one another.

[0110] In one embodiment, a conductive thread comprising silver as the conductive material (i.e., silver conductive thread) can be used with the present device **1**. The silver

thread can comprise a nylon substrate coated or plated with silver, such as SHIELDEX thread (Statex Produktions+ and Vertriebs GmbH, Germany). Silver threads such as this are highly conductive, can be woven like thread, and have reasonably good tensile strength, having an elasticity up to 10 times greater than stainless steel wire of a similar diameter.

[0111] To attach conductive thread **75** to the head strap **10**, the conductive thread is preferably sewn into the elastic substrate of the head strap **10**, as shown in FIG. **26**. An electrode end of the thread is placed into electrical communication with one of the electrodes **70**, such as by soldering the thread **75** to the electrode, and an adjacent portion is placed through the head strap **10** in order to secure it to the head strap **10**. A remainder of the conductive thread **75** can then be sewn into the cloth or other substrate of the head strap **10** until it reaches electrical connector **250** by looping the conductive thread from one surface of the head strap **10** to the other and back, i.e. from an outer surface **9** to an inner surface and back, thereby forming stitches **77** in the manner of sewing. Specifically, the conductive thread **75** can be passed from an outer (upper) surface **9** of the head strap **10** to an inner (lower) surface and then from the inner surface back to the outer surface **9** in a repetitive manner along a longitudinal extent, thereby forming stitches **77** and disposing the conductive thread in a sinuously curved manner along the extent of the head strap. A portion of the conductive thread between the point at which the thread exits a surface of the head strap and the point at which it next enters the head strap (in order to pass through to the other side of the strap) is a stitch **77**, and the length of such stitches can be for example between 0.1 mm and 20 mm, preferably between 0.5 mm and 10 mm, more preferably between 1 mm and 5 mm, and even more preferably 2.5 mm to 3.5 mm.

[0112] In addition to maintaining the conductive thread in contact with or in close proximity to the surfaces of the head strap **10**, thereby preventing the conductive thread from becoming snagged or tangled with other objects and/or from becoming disconnected from electrodes, the elasticity of the head strap is also maintained, because the conductive thread is disposed in sinuously curved, serpentine paths, i.e. in the typical waveform manner imbued by sewing when the thread is conducted from one side of the head strap to the other side and back again. With this sinuous arrangement, the slack formed by transversely disposed portions of the conductive thread allows the longitudinal spacing between peaks and valleys of the sinuously curved thread to increase (up until the point at which the conductive thread becomes essentially linear), i.e. by flattening the height of the thread's waveform, thereby allowing a portion of the head strap **10** to be lengthened without elastically deforming the conductive thread in a significant way, and thus allowing the elastic head strap **10** to be stretched to accommodate the head of a subject. Another way to put this is that the "wavelength" of the sinuously curved conductive thread increases when the head strap **10** is stretched and then decreases when the material in the head strap relaxes.

[0113] In an alternative embodiment, conductive threads can be sewn or otherwise disposed on another substrate, such as on a ribbon of material, which is itself then sewn or otherwise attached to the head strap **10**. The conductive threads would in this case diverge (exit) from the ribbon of material when their respective designated connection point (an electrode or the wireless transmitter **300**) is reached. Alternatively, a conductive thread that comprises a nonconductive

substrate with sufficient elasticity to accommodate stretching of the head strap **10** can be used in the present device, either with or without being sewn onto the head strap **10**.

[0114] Docking Station

[0115] As shown in FIGS. **10-14**, the present EEG device **1** preferably includes a docking station **100** for retaining a wireless transmitter **300**. The outer surface **137** of the docking station **100** is attached at a lower or bottom end **114** to the sagittal strap portion **20** and/or to the coronal strap portion **18** of the head strap **10**. The docking station **100** is preferably attached to the head strap **10** at or near the point at which the head strap **10** contacts the crown of a subject's head, for reasons described further below.

[0116] The docking station **100** generally comprises a base or pedestal **110**, a receptacle **130** for the wireless transmitter **300**, and an electrical connector **250** for providing electrical communication between the wireless transmitter **300** and wires which connect to the electrodes **70** of the head strap **10**. The receptacle **130** and its interior portion **135** can comprise any of a number of configurations capable of retaining the wireless transmitter **300** when it is placed in the interior portion **135** of the receptacle **130**. In the embodiment shown in FIGS. **10-14**, the receptacle comprises a generally rectangular interior space formed by a lower surface **134** of the receptacle **130** and the inner surface **133** of the side walls **136** of the receptacle **130**, and is thus configured to retain a generally rectangular transmitter **300**. In this embodiment, the wireless transmitter can be retained by a friction fit with the inner surface **133** of the side walls **136** of the receptacle **130**, but other retaining means such as clips, straps, ties, or other fasteners known to the art can also be used. A cover (not shown) placed over the wireless transmitter **300** and/or over the upper surface **132** of the receptacle **130** can also optionally be provided in order to protect and/or to help retain the wireless transmitter **300** within the receptacle **130**. The cover could be secured to or integrally molded with the side walls **136**, or could be reversibly secured to the receptacle **130**, such as with hook and loop fasteners.

[0117] The docking station **100** further includes one or more openings **150** for receiving wired connections. In the embodiment shown in FIGS. **11-14**, the electrical connector **250** and a plurality of wires **200** in electrical communication with the plurality of electrodes **70** of the present device **1** are placed in communication with the interior **135** of the receptacle **135** through an opening **152** in the rear face of the docking station **100**. When the present device is in use, the wireless transmitter **300** is connected to the electrodes **70** by means of a reversible connection with the electrical connector **250**. The electrical connector can be, for example, a jack such as a 10 pin connector having a distal receiving end **251** in communication with the interior of the receptacle **130**. The transmitter **300** is provided with a mating electrical connector, for example a plug (**210**, shown in FIG. **17**).

[0118] Each of the wires **200** (which can be conductive threads) connected to respective electrodes **70** connect at the proximal end **253** of the electrical connector **250**. Preferably, the wires or conductive threads are protected by a covering, such as a wrapped or molded plastic layer when they extend away from the head strap **10** to the electrical connector **250**.

[0119] A second opening **151** is also preferably provided at the front end of the docking station **100** to allow wired access to a second connector (**212**, FIG. **18**) on the wireless transmitter **300** while it is retained within the receptacle **130**. The second connector **212** is preferably an 8 pin port to allow

charging of the transmitter **300** while it is retained in the docking station **100**. Alternatively or in addition, the second connector can be used to communicate with the transmitter **300** and program the transmitter's firmware, for example.

[0120] For hygienic purposes, the portions of the present system with which a subject might come into contact, namely the docking station **100** and head strap **10**, are preferably made from relatively low-cost materials that can be disposed of after use. The docking station **100**, for example, can be formed from an expanded, rubberized polymer foam material such as ethylene-vinyl acetate (EVA), expanded polyethylene foam, or expanded polypropylene foam. The use of a foam material also provides the advantages of being light as well as being soft and therefore more comfortable when worn by a patient. Foam materials also provide shock resistance and thus better protect the transmitter **300**.

[0121] In addition, the material used to form at least the base **110** of the device, and preferably also the receptacle **130**, is preferably transparent to X-rays such that the material absorbs, scatters and/or reflects less than 20% of the X-ray radiation it receives, more preferably less than 10% of such radiation, and even more preferably less than 1%. When the base **110** of the docking station **100** is placed at the crown of a subject's head and is formed from a material which is substantially transparent to X-rays, a subject wearing the head strap **10** and docking station **100** of the present EEG device **1** can be placed within a CT scanner and receive a CT scan without needing to remove the present EEG device. This is advantageous because an EEG may provide an indication that further imaging (such as a CT scan) is needed, and in this case a subject can receive the scan without having to remove the EEG device from the patient, so that the patient's brain activity can continue to be monitored with the present device following the CT scan. Alternatively, an X-ray image can be obtained while a subject is wearing the head strap **10** and docking station **100** of the present device **1**.

[0122] In a particularly preferred embodiment, the base **110** is a pedestal having a thickness greater than the walls of the receptacle **130** of the docking station **100**. By providing such a pedestal for the docking station **100**, the wireless transmitter **300** is retained further from the top of a subject's head, thereby reducing the possibility of interference between the wireless transmitter **300** and a CT scanner during a CT scan of the subject. The pedestal can for example be between 6 millimeters and 3 centimeters in thickness, but is preferably between 1.3 centimeters and 2.5 centimeters thick. In some embodiments, the base **110** and receptacle **130** can be integrally formed, such as by molding.

[0123] Wireless Transmitter

[0124] The wireless transmitter **300** that is retained by the docking station **100** is adapted to facilitate both wireless and wired transmissions to a processing system. As shown in FIG. **15**, the transmitter **300** has a top surface **201** with a user interface **202**. In the depicted embodiment, the user interface **202** includes a test input **204**, a power indicator **206** and one or more electrode impedance indicators **208**. The power indicator **206** is adapted to indicate whether the transmitter is powered ON or OFF. In the depicted example, the power indicator **206** is implemented as a light, as shown in FIG. **16**. In this example, the light turns on when the transmitter **300** is powered ON.

[0125] As shown in FIGS. **15** and **16**, the electrode impedance indicators **208** are adapted to indicate to a user whether the impedance of a particular electrode **70** is above some

threshold level. Each indicator **208** is associated with a specific electrode **70** so the user can identify which, if any, electrodes **70** are experiencing poor impedance. In the depicted example, the electrode impedance indicators **208** are LED lights located relative to one another so as to correlates to the relative position of the respective electrode **70** on the subject's head, and are disposed within a graphic image depicting a top plan view of a subject's head. These lights can glow one color (e.g., green) when impedance levels for a respective electrode **70** is below a predefined threshold, and can glow a different color (e.g., red) when the impedance level is above the predefined threshold. In some embodiments, the predefined threshold is about 15 kilohms, so that an impedance level below 15 kilohms will cause the indicator **208** to indicate the impedance is acceptable, while an impedance above 15 kilohms will cause the indicator **208** to indicate the impedance is not acceptable.

[0126] The transmitter **300** includes an electrode interface **210** shown in FIG. **17** for facilitating electrical communication with each of the electrodes **70**. In this manner signals can be conveyed between (e.g., from) each electrode **70** and the transmitter **300**.

[0127] The transmitter **300** can also include a remote device interface **212** shown in FIG. **18** and adapted to couple the transmitter **300** with a remote device through a wired connection. In this manner, the transmitter **300** can be communicatively coupled via a wired connection with one or more remote devices.

[0128] FIG. **19** shows a block diagram of the transmitter **300** according to at least one embodiment. The transmitter **300** includes a processing circuit **214** coupled to or placed in electrical communication with a communications interface **216**, a storage medium **218**, and a user interface **220**.

[0129] The processing circuit **214** is adapted for processing, including the execution of programming, which may be stored on the storage medium **218**. Accordingly, the processing circuit **214** is arranged to obtain, process and/or send data, control data access and storage, issue commands, and control other desired operations. The processing circuit **214** may include circuitry configured to implement desired programming provided by appropriate media in at least one example. For example, the processing circuit **214** may be implemented as one or more processors, one or more controllers, and/or other structure configured to execute executable programming. Examples of the processing circuit **214** may include a general purpose processor, a digital signal processor (DSP), an application specific integrated circuit (ASIC), a field programmable gate array (FPGA) or other programmable logic component, discrete gate or transistor logic, discrete hardware components, or any combination thereof designed to perform the functions described herein. A general purpose processor may include a microprocessor, as well as any conventional processor, controller, microcontroller, or state machine. The processing circuit **214** may also be implemented as a combination of computing components, such as a combination of a DSP and a microprocessor, a number of microprocessors, one or more microprocessors in conjunction with a DSP core, an ASIC and a microprocessor, or any other number of varying configurations. These examples of the processing circuit **214** are for illustration and other suitable configurations within the scope of the present disclosure are also contemplated.

[0130] According to one or more aspects of the present disclosure, the processing circuit **214** may be adapted to

perform (in conjunction with the storage medium **218**) any or all of the processes, functions, steps and/or routines described herein for the transmitter **300**.

[0131] The communications interface **216** is configured to implement wireless and/or wired communications of the transmitter **300**. For example, in some embodiments, the communications interface **216** can be configured to communicate information bi-directionally with respect to one or more other devices (e.g., another processing system). The communications interface **216** can be coupled with an antenna (not shown) and can include wireless transceiver circuitry for wireless communications with wireless devices. In some embodiments, the wireless transceiver circuitry is configured to facilitate Bluetooth communications. In other embodiments, the wireless transceiver circuitry can be configured to facilitate other wireless communications, such as WiFi, Zigbee, Wireless USB, or other wireless wide area network (WWAN) standards, wireless local area network (WLAN) standards, and/or wireless personal area network (WPAN) standards. The communications interface **216** can also include a network interface (e.g., a network interface card (NIC)) for the electrode interface **210** shown in FIG. **17** and the remote device interface **212** shown in FIG. **18**. The network interface may be implemented as a serial or parallel connection, a USB port, a Firewire interface, a flash memory interface, a floppy disk drive, or any other suitable arrangement for communicating with respect to public (e.g., Internet) and/or private networks or other wired arrangements.

[0132] The storage medium **218** may represent one or more computer-readable, machine-readable, and/or processor-readable devices for storing programming, such as processor executable code or instructions (e.g., software, firmware), electronic data, databases, or other digital information. The storage medium **218** may also be used for storing data that is manipulated by the processing circuit **214** when executing programming. The storage medium **218** may be any available media that can be accessed by a general purpose or special purpose processor, including portable or fixed storage devices, optical storage devices, and various other mediums capable of storing, containing or carrying programming. By way of example and not limitation, the storage medium **218** may include a computer-readable, machine-readable, and/or processor-readable storage medium such as a magnetic storage device (e.g., hard disk, floppy disk, magnetic strip), an optical storage medium (e.g., compact disk (CD), digital versatile disk (DVD)), a smart card, a flash memory device (e.g., card, stick, key drive), random access memory (RAM), read only memory (ROM), programmable ROM (PROM), erasable PROM (EPROM), electrically erasable PROM (EEPROM), a register, a removable disk, and/or other mediums for storing programming, as well as any combination thereof.

[0133] The storage medium **218** may be coupled to the processing circuit **214** such that the processing circuit **214** can read information from, and write information to, the storage medium **218**. That is, the storage medium **218** can be coupled to the processing circuit **214** so that the storage medium **218** is at least accessible by the processing circuit **214**, including examples where the storage medium **218** is integral to the processing circuit **214** and/or examples where the storage medium **218** is separate from the processing circuit **214** (e.g., resident in the transmitter **300**, external to the transmitter **300**, distributed across multiple entities).

[0134] As noted above, the user interface **202** includes the test input **204**, the power indicator **206** and one or more

electrode impedance indicators **208** shown in FIG. **15**. Although the embodiment in FIG. **15** employs LEDs for the power indicator **206** and the electrode impedance indicators **208**, other indicators may be employed. For example, the electrode impedance indicators **208** may include any display capable of visually indicating to a user that an impedance value is above some predetermined threshold, such as a spectrum display showing relative impedance values, an LED or LCD screen, etc.

[0135] In some embodiments, the user interface **202** may include an audio impedance indicator adapted to provide an audio indication (e.g., a buzzing sound, a beeping sound, etc.) when an impedance value for one or more electrodes is above the predetermined threshold. For example, the user interface **202** may include an audio transducer coupled with the processing circuit **214**. The processing circuit **214** can cause the audio transducer to generate an audible noise when an impedance value of one or more electrodes is above the predetermined threshold. The audible noise can aid in drawing a user's attention to the occurrence of unacceptably high impedance in one or more electrodes, and the electrode impedance indicators **208** can identify to the user which electrode(s) are exhibiting the high impedance.

[0136] Turning to FIG. **20**, a more detailed block diagram is shown according to at least one embodiment of the transmitter **300**. As shown, the processing circuit **214** may include an impedance excitation module **222**, a plurality of preamps **224**, a signal conditioning multiplexer **226**, and a data acquisition controller and analog-to-digital converter (ADC) **228**. In at least one embodiment, the processing circuit **214** can be implemented with an integrated circuit chip, such as one of the integrated circuits sold under the names ADS **1294R**, ADS **1296R**, or ADS **1298R** by TEXAS INSTRUMENTS. These integrated circuits include multichannel, simultaneous sampling, 24-bit delta-sigma analog-to-digital converters (ADCs) with built-in programmable gain amplifiers (PGAs), internal reference, and an onboard oscillator commonly employed in medical electrocardiogram (ECG) and electroencephalogram (EEG) applications. In other embodiments, one or more of the forgoing modules and elements may be implemented as separate and individual circuits and/or modules.

[0137] In operation, the transmitter **300** receives respective electrical signals from a plurality of electrodes **70** (e.g., eight in FIG. **20**) via the electrode interface **210** of the communications interface **216**. These received signals represent the electrical signals each electrode **70** received from the subject's brain, and may be referred to as brain signals. These signals are amplified at a preamp **224**, and the amplified signals can be converted from analog to digital signals in the analog-to-digital converter **228**.

[0138] The digital signals for each electrode signal can be transmitted to a remote device **232** through the wireless transceiver **230**. In some embodiments, the digital signals are transmitted by means of a Bluetooth transmission. In other embodiments, the digital signals are transmitted by means of a wired connection, such as a cable coupled to the remote device interface **212** and also coupled to the remote device **232**.

[0139] The transmitter **300** also measures an impedance for each electrode **70**. The impedance measurements can be used to determine whether the electrodes **70** are properly coupled to the subject's head and/or are functioning properly. A high impedance may indicate that the electrode **70** is not suffi-

ciently coupled to the subject's head, that the electrode **70** is not functioning well or properly, or that the electrode **70** is defective for some reason. For instance, a needle, disc or cup electrode that has come loose from the subject's scalp will exhibit relatively high impedance. Similarly, if the conductive liquid, hydrogel or solid gel of a wet electrode has dried out, the electrode will typically exhibit relatively high impedance. Furthermore, an electrode that is coupled to a broken or otherwise defective conductive thread may exhibit relatively high impedance.

[0140] To obtain the impedance measurements, the impedance excitation module **222** can inject a DC or AC current into each of the electrodes **70**. The processing circuit **214** can then measure the voltage generated for each electrode **70** from the injected current to determine an impedance value with respect to the reference signal. The processing circuit **214** can then determine whether each respective impedance value is above or below a predefined threshold. In at least some embodiments, the impedance measurements can be obtained at least substantially simultaneously with receiving the electrical signals each electrode **70** receives from the subject's brain.

[0141] According to at least one aspect, the transmitter **300** can visually display via an electrode impedance indicator **208** whether the impedance associated with each electrode is above or below a predetermined threshold. For instance, the processing circuit **214** can cause a respective impedance test LED in the user interface **202** to indicate that the impedance for the particular electrode **70** is within an allowable range (e.g., below 15 kilohms) or outside of an allowable range (e.g., above 15 kilohms).

[0142] According to at least one aspect, the transmitter **300** can wirelessly transmit the measured impedance values associated with each electrode **70** via the wireless transceiver **230**. These measured impedance values can be sent at least substantially simultaneously with the signals from each electrode **70** obtained from the subject's brain. For Bluetooth transmissions, the wireless signals are transmitted in a 2.4 gigahertz frequency (e.g., 2.4-2.48 gigahertz). When the wireless transceiver **230** transmits the brain signals from each electrode **70** using Bluetooth transmissions (e.g., over various channels in the range of 2.4 gigahertz to 2.48 gigahertz), the measured impedance values for each electrode **70** can be transmitted at least substantially simultaneously as a 62.5 hertz waveform on top of the Bluetooth signal. In at least some instances, the amplitude of the 62.5 hertz waveform can be roughly inversely proportional to the impedance value. In some embodiments, the wireless transmission of the measured impedance values can be turned on or off at the transmitter by a user.

[0143] The remote device **232** can receive the transmission including the two data streams and can filter out the measured impedance values from the brain signals for processing each of the signals independently.

[0144] As a result of the transmitter **300** measuring the impedance at least substantially continuously, the transmitter **300** and/or the remote device **232** can employ the impedance measurements for conditioning the signals before the signals are processed. For example, the transmitter **300** and/or the remote device **232** can employ the impedance values associated with a respective electrode to boost (e.g., amplify) the electrical signals received from the respective electrode.

[0145] As shown in FIG. **21**, the transmitter **300** can be employed in a variety of different network environments. Generally speaking, the transmitter **300** can convey the elec-

trical brain signals and respective impedance values from each electrode to a remote device. In various examples, the transmitter 300 can convey such information wirelessly via a wireless wide area network (WWAN), a wireless local area network (WLAN), and/or a wireless personal area network (WPAN). In at least some embodiments, the transmitter 300 communicates with the remote device 232 via a WPAN employing Bluetooth communication standards. In other embodiments, the transmitter 300 communicates with the remote device 232 via a wired network, such as a direct cable coupled between the transmitter 300 and the remote device 232.

[0146] As illustrated in FIG. 21, the transmitter 300 can, for example, transmit signals via a Bluetooth signal 231 or other short-range communication standard to a remote device 232 such as a smartphone 241, a tablet computer 242, a laptop computer, an existing EEG acquisition device 243, or a vital-sign monitor 244. The remote device 232 can be configured to process the received signals and generate one or more visual outputs for a user to evaluate. Alternatively, the transmitter 300 can be connected by a wired (cable) connection to another device.

[0147] In some instances, the remote device 232 can further convey the received information and/or additional information determined from the received information to one or more other devices and/or displays 234. The remote device 232 may convey the received and/or additional information via a wide area network (WAN), a local area network (LAN), a personal area network (PAN), including one or more combinations thereof. Such networks may include wireless and/or wired networks. FIG. 21 shows some non-limiting examples including via a cloud network 251, a dedicated network 252, a hospital network 253 and/or a monitoring system network 254.

[0148] The one or more other devices and/or displays 234 can include additional processing systems similar to the remote devices 232, as well as displays. Some non-limiting examples include a computer 261 (e.g., laptop, desktop, tablet, etc.), a nurses station ICU monitoring system 262, an EEG review station 263, and a generic display 264. Although specific combinations are depicted in FIG. 21, it will be apparent that other combinations of the depicted examples, as well as combinations including different networks and/or devices are also possible.

[0149] Although the various examples refer to transmissions sent by the transmitter 300, the transmitter 300 can also be adapted to receive communications via a wireless or wired network. For example, the transmitter 300 may receive communications from a remote device 232 via a WPAN employing Bluetooth communication standards and/or via a wired network. Such communications can, for example, enable the transmitter 300 to be remotely controlled. For instance, a remote device 232 may enable or disable the impedance measurement operations of the transmitter 300 and/or modify one or more operating parameters including gain, initiation of a memory dump, or powering down.

Simplified EEG Interface

[0150] In order to detect medical conditions with an EEG, waveforms which have relatively uniform morphology and duration are detected, and the interval between consecutive waveforms is determined. In particular, waveforms which occur at regular intervals can be indicative of a condition in need of treatment. Waveforms being detected are preferably

consistent and of greater amplitude than other waves, with the amplitude being relatively consistent. A range of the ratio of the amplitude of the wave to the amplitude of the interval (Amp W/Amp I) can be used to define particular waveforms of interest, with a relative standard deviation measure of this ratio being used to determine the consistency of the waveform.

[0151] EEG's are typically displayed as a graph comprising a series of lines showing waves of varying amplitude and wavelength in linear form, with each line corresponding to a signal received from an electrode of an EEG device. In order to interpret whether such waveform patterns present an indication of a brain injury or other medical condition, they must be evaluated by a trained technician or expert.

[0152] The present system preferably comprises a simplified user interface 400 for evaluating EEG readings. This interface provides rapid, accurate and more easily interpreted information to a medic or other user of the present system regarding the nature and severity of any EEG abnormalities measured by the present system, thereby reducing the need to analyze more complex waveform patterns displayed in typical EEG readings and increasing medical response times. In addition, the present interface 400 can display brain wave pattern information in a dynamic format, providing continuous EEG monitoring data during transport of a subject and during therapeutic interventions.

[0153] In order to create such a simplified interface, EEG data from electrodes measuring data from each hemisphere of a subject's brain is first analyzed separately, such as by a microprocessor, in predetermined time segments, in order to determine whether predetermined waveform patterns are present in each time segment. Such predetermined segments preferably range between 5 seconds and 20 seconds, and are advantageously 10 seconds in length. Waveform patterns are preferably analyzed to determine whether they correspond to patterns associated with clinically significant, moderate to severe, acute or progressive brain damage. These patterns, which are known to those skilled in the art, include suppression, slowing, burst-suppression, inter-hemisphere asymmetry, periodic epileptiform discharges (PEDS), and seizure. Algorithms for determining these waveform patterns are likewise known [see, e.g., Claasen, J, et al., "Quantitative Continuous EEG for detecting delayed cerebral ischemia in patients with poor grade subarachnoid hemorrhage," *Clinical Neurophysiology*, 2004, 115:2699-2710; Steward C P, et al., "Seizure identification in the ICU using quantitative EEG displays," *Neurology*, 2010, 75:1501-1506; Zandi A S, et al., "Automated real-time epileptic seizure detection in scalp EEG recordings using an algorithm based on wavelet packet transform," *IEEE Trans Biomed Eng.*, 2010, 57(7):1639-1651; White, A M, et al., "Efficient unsupervised algorithms for the detection of seizures in continuous EEG recordings from rats after brain injury," *Journal of Neuroscience Methods*, 2006, 152:255-266].

[0154] When data from a particular time segment is found to match the pattern for one of the predetermined waveform patterns, it is displayed using an indicator from a predetermined set of visually distinguishable indicia, for example visually distinguishable colors, patterns, shadings, and/or other visual referents. In one embodiment, the simplified interface displays a predetermined color to indicate a waveform pattern. For example, a waveform pattern indicative of a seizure might be displayed with the color red (as indicated with white bars 402 in FIG. 24), while waveform patterns in

a normal range might be displayed in blue (indicated in FIG. 24 with bars 404 having parallel lines). The graphical form of the indicia associated with such displayed color can take any of a number of forms. In the form shown in FIGS. 24 and 25, the colored indicia are displayed as vertical bars 410 which are set out horizontally in temporal order to form indicia sets 401. As can be seen in FIG. 24, the indicator is displayed as a single bar when a single time segment corresponds to the predetermined wave pattern, as shown by the blue bar 405 in FIG. 24. When multiple time segments correspond to the same wave pattern, they can be indicated as a series of separate indicia, but in a preferred embodiment are indicated as a continuous band of colored indicia having a length equal to the sum of the number of indicia that correspond to the wave pattern, as with the plurality of indicia indicated by the horizontal band 405 in FIG. 24, made up of a plurality of vertical bars 410. Separate indicia sets 401 are displayed for the right and left hemispheres of a subject's brain, shown as left hemisphere indicia set 412 and right hemisphere indicia set 414 in FIG. 24.

[0155] The present interface 400 preferably shows a moving display of brain wave patterns over time as in the display of FIG. 24. A vertical time bar 420 preferably tracks the time point (in real time or recorded time) at which a brain wave pattern has been detected. The time bar preferably tracks both hemispheres of a subject's brain together in parallel, i.e. with the time bar 420 intersecting the indicia for a predetermined point of time for the subject's right hemisphere and also intersecting the indicia for the same point of time for the subject's left hemisphere. An indicator of actual or elapsed testing time 416 can be included in parallel with the indicia sets 400. In order to review the progress of an EEG, the portion of the analyzed EEG indicia sets 401 viewable in the interface window can be manipulated, such as with scrolling bar 430. Scrolling through the indicia sets in this way can assist a technician or other expert viewing the EEG to identify trends quickly.

[0156] As shown in FIG. 22, the present interface further preferably comprises a simplified user interface comprising a graphic 450 having two distinct, predetermined portions or display areas, preferably a right half 454 and left half 452. In FIG. 22 the graphic 450 is in the form of a top plan view of a head and the right and left hemispheres of a brain in stylized form. The display areas 455 display the color of the indicia corresponding to a particular time segment of the EEG, such as the segment represented by the "blue" bar 410 in FIG. 24. As shown in FIG. 24, during the time segment corresponding to the bar 410, the subject's left hemisphere is experiencing a wave pattern indicated by the color blue, while the subject's right hemisphere is experiencing a pattern indicated with the color red (bar 402). When the graphic 450 is used with the indicia sets 401, when the time bar 420 is at the time segment of bar 410, the graphic 450 is likewise colored to indicate that the subject's left hemisphere is experiencing a brain wave pattern indicated by the color blue while the subject's right hemisphere is experiencing a pattern indicated by the color red. It has been found that displaying wave pattern information with both the temporally displayed indicia sets 401 and the graphical representation 450 facilitates a more rapid and accurate determination of the status of a subject's brain.

[0157] In a preferred embodiment, as shown in FIG. 23, the interface 400 can also include an electrode status display with a continuous or periodically updated indicator of the integrity of each electrode. Like the graphic 450, the electrode status

display 460 preferably has two distinct portions or display areas, such as a right half 464 and left half 462, which are also likewise in the form of the outline of the top of a human head. The appearance of a graphic or other indicia 465 corresponding to a particular electrode of the associated EEG device can indicate a rising impedance or disconnection of that electrode, and thereby inform a technician obtaining the EEG that the electrode needs to be reattached or replaced.

[0158] A preferred embodiment of the present interface is shown in FIG. 25. In this embodiment the interface includes a real-time, continuously running, and color-coded landscape view of the EEG analysis in the form of the indicia sets 401 at the top of the screen. Below the landscape view are two schematized head views 450 and 460 (as seen from the vertex divided into left and right hemispheres), with the hemispheres of the graphic 450 filled in with colors corresponding to the specific abnormal patterns detected over time and the graphic 460 displaying no indicia (indicating that all electrodes of the EEG device are functioning). The right head view 460 displays the presence of excessive 60 Hz or baseline sway artifacts from recording electrodes.

Methods of Use

[0159] The present device has applications in any of a number of emergency situations, but particularly those that are currently underserved due to the difficulty of setting up EEG electrodes on a subject's scalp and the lack of availability of equipment adapted for emergency environments. One such environment is the battlefield, where head trauma and resulting brain injury are all too common. Traumatic brain injury may not be easily detected early on, as mental status testing can be subjective and depend on the examiner and the subject. Symptoms of brain injury can also resemble psychological reactions, so signs of such injury may not be immediately detectable in the absence of EEG. If undetected and left untreated, such injuries may progress to secondary brain injuries such as traumatic cerebral contusions (TCC), intra-parenchymal hemorrhages (IPH), epidural hematomas, acute subdural hematomas (SDH), secondary ischemic stroke, or seizures. In non-military situations, the present EEG device has particular use in view of its ease of set-up and use for evaluating hypothermia for post-cardiac arrest comatose survivors; managing acute traumatic brain injury in hospital emergency departments; diagnosing coma and seizures in emergency departments; treating status epilepticus in the field; diagnosing acute sport concussions; monitoring hospital stroke and stroke-at-risk patients; and neonatal ICU EEG monitoring.

Examples

EEG with Copper Thread

[0160] Two individuals were fitted with the present device, one with a plastic disc electrodes and the other with a subdermal needle electrodes. The electrodes of both devices were connected to a wireless transmitter as described above with copper thread. The devices produced high quality and stable EEG data from all electrodes without artifacts. Impedances for both models were excellent, below 5-10 ohms, and were well-balanced. Each device was tested for 10 continuous minutes of recording. The subjects experienced no adverse effects.

[0161] Although the present invention has been described in considerable detail with reference to certain preferred embodiments, other embodiments are possible. The steps disclosed for the present methods, for example, are not intended to be limiting nor are they intended to indicate that each step is necessarily essential to the method, but instead are exemplary steps only. Therefore, the scope of the appended claims should not be limited to the description of preferred embodiments contained in this disclosure.

[0162] Recitation of value ranges herein is merely intended to serve as a shorthand method for referring individually to each separate value falling within the range. Unless otherwise indicated herein, each individual value is incorporated into the specification as if it were individually recited herein. All references cited herein are incorporated by reference in their entirety.

1. A wireless EEG device, comprising:
 - (a) a head strap for retaining a plurality of electrodes on the head of a subject, the head strap comprising at least a sagittal strap portion;
 - (b) a docking station attached to the sagittal strap portion at the crown of the subject's head, the docking station comprising:
 - a base formed from a material which is transparent to X-rays; and
 - a receptacle supported by the base; and
 - (c) a wireless transmitter in electrical communication with the plurality of electrodes for transmitting an electrical signal received by the electrodes from the subject's brain, wherein the wireless transmitter is securely retained within the receptacle of the docking station.
2. The wireless EEG device of claim 1, wherein the base is formed from a foam material having a thickness of at least 1.3 centimeters, preferably of between 2.5 and 6 centimeters.
3. The wireless EEG device of claim 1, wherein the base and the receptacle are integrally formed.
4. The wireless EEG device of claim 1, wherein the base and the receptacle are formed from a material that absorbs, scatters and/or reflects less than 20% of X-ray radiation received by the base and the receptacle, more preferably less than 10%, and even more preferably less than 1%.
5. The wireless EEG device of claim 1, wherein non-ferromagnetic electrically conductive thread is used to place the plurality of electrodes in electrical communication with the wireless transmitter.
6. The wireless EEG device of claim 1, wherein the electrodes are selected from the group consisting of a needle electrode, a disc electrode, and a cup electrode.
7. The wireless EEG device of claim 1, further comprising a cover placed over the wireless transmitter.
8. A method of testing a subject for a brain injury, comprising the steps of:
 - placing the wireless EEG device of claim 1 on a subject's head;
 - performing a CT scan or obtaining an X-ray image of the subject's head; and
 - performing electroencephalography (EEG) with the device.
9. (canceled)
10. An EEG device, comprising:
 - (a) a head strap formed from an elastic material, the head strap comprising a plurality of head strap portions which extend across a plurality of EEG electrode positions on the head of a subject, the electrode positions being

selected from the group consisting of Fp1, Fp2, F7, F3, Fz, F4, F8, A1, T3, Cz, C3, C4, T4, A2, T5, P3, Pz, P4, T6, O1, and O2;

- (b) a plurality of electrodes attached to the head strap at the plurality of EEG electrode positions;
 - (c) a plurality of non-ferromagnetic electrically conductive threads, each conductive thread being in electrical communication at a first end with one of the plurality of electrodes and at a second end with an electrical connector, wherein the conductive thread is secured to the head strap by passing the conductive thread from an upper surface of the head strap to a lower surface and then from the lower surface to the upper surface in a repetitive manner along a longitudinal extent, thereby disposing the conductive thread in a sinuously curved manner along the extent of the head strap.
11. The EEG device of claim 10, wherein the conductive threads comprise copper or silver.
 12. The EEG device of claim 10, wherein the conductive threads each have a diameter of between 0.5 millimeters (mm) and 5 mm, preferably between 2 mm and 4 mm.
 13. The EEG device of claim 10, wherein at least a portion of one or more of the conductive threads is disposed in stitches having a length of between 0.5 mm and 10 mm, more preferably between 1 mm and 5 mm, and even more preferably between 2.5 mm and 3.5 mm.
 14. The EEG device of claim 10, wherein the conductive threads each are surrounded by an electrically insulating material.
 15. The EEG device of claim 10, wherein the electrical connector is in electrical communication with a transmitter.
 16. (canceled)
 17. A transmitter adapted for use with an EEG device, comprising:
 - (a) a communications interface comprising an electrode interface communicatively coupled to a plurality of electrodes;
 - (b) a user interface including at least one electrode impedance indicator; and
 - (c) a processing circuit coupled with the communications interface and the user interface, the processing circuit adapted to:
 - receive a respective electrical signal from each of the plurality of electrodes;
 - measure an impedance associated with each electrode of the plurality of electrodes; and
 - visually display via the at least one electrode impedance indicator whether the impedance associated with each electrode is above or below a predetermined threshold.
 18. The transmitter of claim 17, wherein the communications interface further comprises a wireless transceiver, and wherein the processing circuit is further adapted to simultaneously transmit via the wireless transceiver the impedance associated with each electrode and an electrical signal received by each electrode from a subject's brain.
 19. (canceled)
 20. A method of evaluating brain activity of a subject with an EEG, comprising:
 - obtaining an EEG from the subject, the EEG comprising waveforms generated by electrical activity within each of the two hemispheres of the brain of the subject, wherein the waveforms occur in predetermined patterns;

displaying the waveform patterns of the subject's brain as visually distinguishable indicia in temporal order and in a linear fashion, thereby forming a temporal waveform record in graphical form, the waveform patterns for each hemisphere of the subject's brain being displayed separately, wherein a predetermined indicia indicates a predetermined waveform pattern;

displaying a time indicator in the temporal waveform record, the time indicator designating a time point in the temporal waveform record; and

displaying a graphical image having two adjacent predetermined display areas, wherein the indicia displayed in each display area corresponds to the indicia in the temporal waveform record for a respective hemisphere of the subject's brain at the point in the temporal waveform record where the time indicator is displayed.

21. (canceled)

22. The method of claim **20**, wherein EEG data from the EEG is processed in predetermined time segments, the time segments preferably being between 5 seconds and 20 seconds in length, and advantageously being 10 seconds in length.

23. The method of claim **20**, wherein the waveform patterns include patterns selected from the group consisting of suppression, slowing, burst-suppression, inter-hemisphere asymmetry, periodic epileptiform discharge, and seizure.

24. The method of claim **20**, wherein waveform patterns of both hemispheres of the subject's brain are displayed together.

* * * * *

专利名称(译)	无线脑电图		
公开(公告)号	US20150257674A1	公开(公告)日	2015-09-17
申请号	US14/435728	申请日	2013-10-15
[标]申请(专利权)人(译)	JORDAN NEUROSCI		
申请(专利权)人(译)	JORDAN神经科学, INC.		
当前申请(专利权)人(译)	JORDAN神经科学, INC.		
[标]发明人	JORDAN KENNETH GEORGE LOUBERT GARY BAKKOM DAVID		
发明人	JORDAN, KENNETH GEORGE LOUBERT, GARY BAKKOM, DAVID		
IPC分类号	A61B5/0478 A61B5/00 A61B5/04 A61B6/03		
CPC分类号	A61B5/0478 A61B5/04012 A61B5/0006 A61B6/032 A61B5/6803 A61B5/6843 A61B5/6844 A61B6/4417 A61B6/501 A61B2562/17		
优先权	61/713754 2012-10-15 US		
其他公开文献	US10130278		
外部链接	Espacenet USPTO		

摘要(译)

一种用于执行EEG的装置，包括弹性头带，电极和无线发射器。显示电极阻抗指示器的无线发射器使用连接到受试者头部冠部的头带的对接站固定到患者，并使用缝合到头带中的导电线与电极进行电连通。包括图形元素的简化用户界面改进了脑波模式的检测。

