



(19) **United States**
(12) **Patent Application Publication**
GELBART et al.

(10) **Pub. No.: US 2015/0126993 A1**
(43) **Pub. Date: May 7, 2015**

(54) **APPARATUS AND METHOD FOR INTRA-CARDIAC MAPPING AND ABLATION**

A61B 5/029 (2006.01)
A61B 5/00 (2006.01)
A61B 18/10 (2006.01)
A61B 5/028 (2006.01)

(71) Applicant: **KARDIUM INC.**, Burnaby (CA)

(72) Inventors: **Daniel GELBART**, Vancouver (CA);
Samuel Victor LICHTENSTEIN,
Vancouver (CA)

(52) **U.S. Cl.**
CPC *A61B 18/1492* (2013.01); *A61B 18/10*
(2013.01); *A61B 5/028* (2013.01); *A61B 5/029*
(2013.01); *A61B 5/6853* (2013.01); *A61B*
19/56 (2013.01); *A61B 18/18* (2013.01)

(21) Appl. No.: **14/546,542**

(22) Filed: **Nov. 18, 2014**

(57) **ABSTRACT**

Related U.S. Application Data

(63) Continuation of application No. 11/475,950, filed on Jun. 28, 2006, now Pat. No. 8,920,411.

An intra-cardiac mapping system is based on locating the ports through which blood flows in or out of the heart chambers. For many procedures, such as ablation to cure atrial fibrillation, locating the pulmonary veins and the mitral valve accurately allows to perform a Maze procedure. The location of the ports and valves is based on using the convective cooling effect of the blood flow. The mapping can be performed by a catheter-deployed expandable net or a scanning catheter. The same net or catheter can also perform the ablation procedure.

Publication Classification

(51) **Int. Cl.**
A61B 18/14 (2006.01)
A61B 19/00 (2006.01)

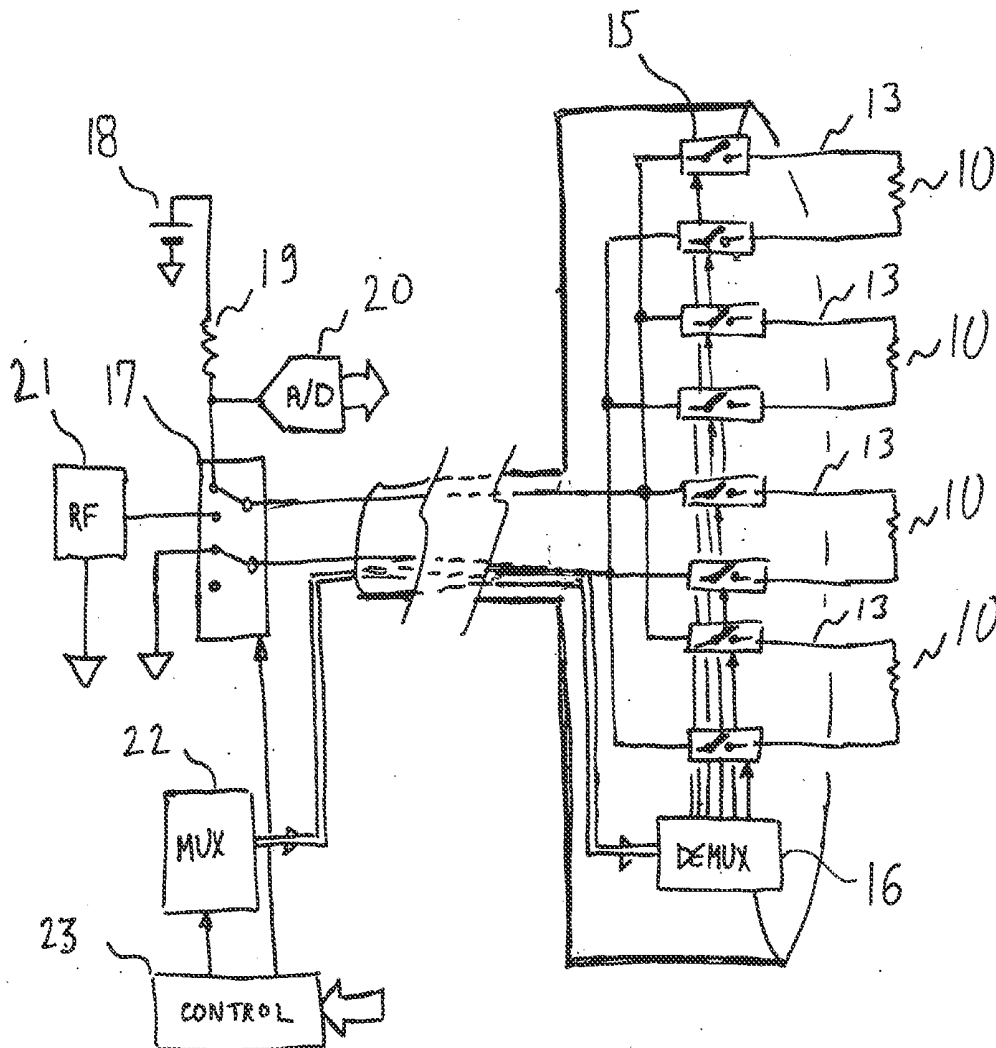

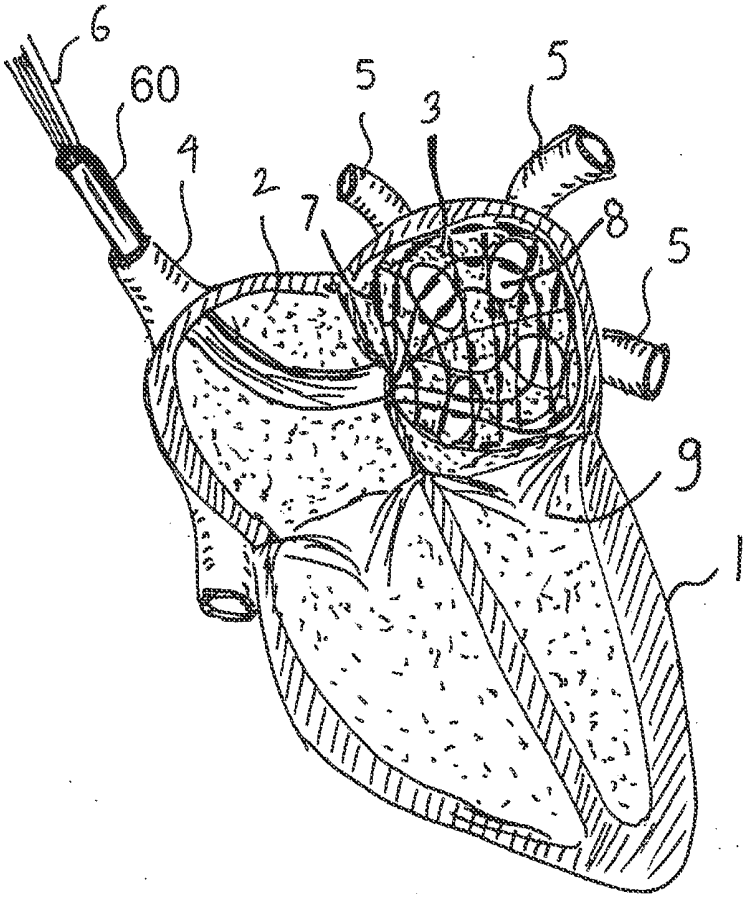

Fig 1

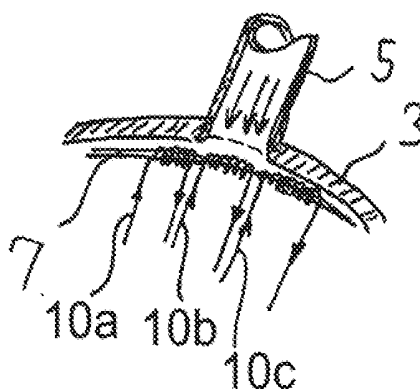

FIG. 2

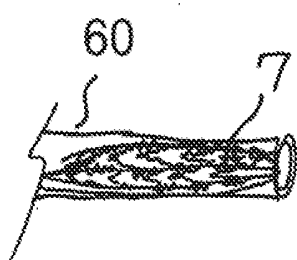

FIG. 3A

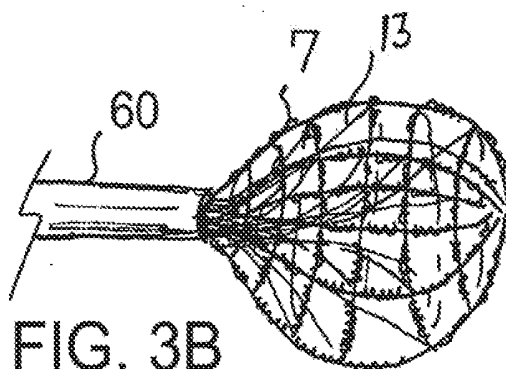

FIG. 3B

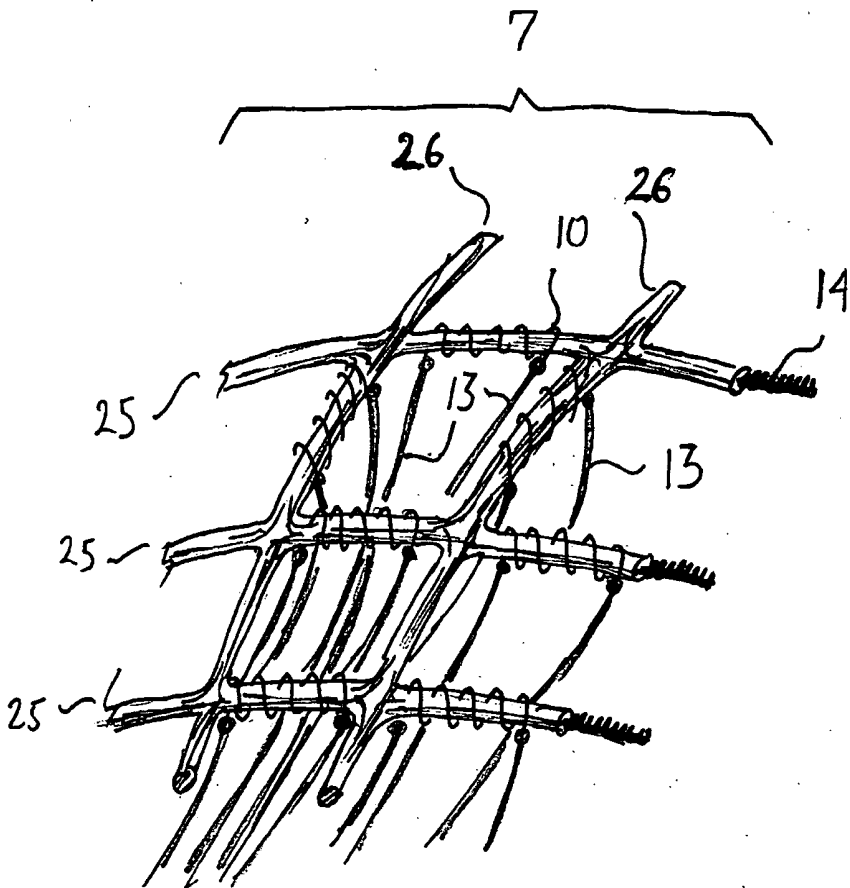

Fig 4

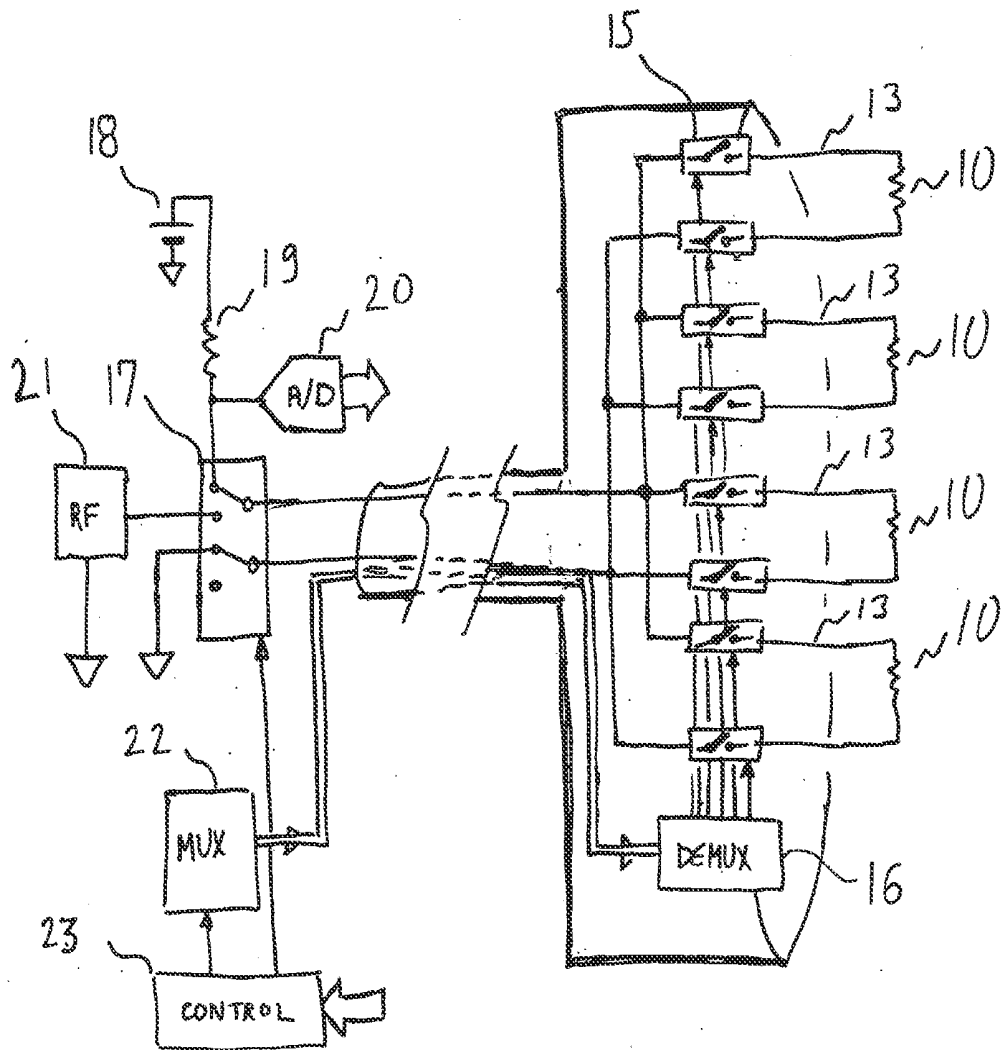

Fig 5

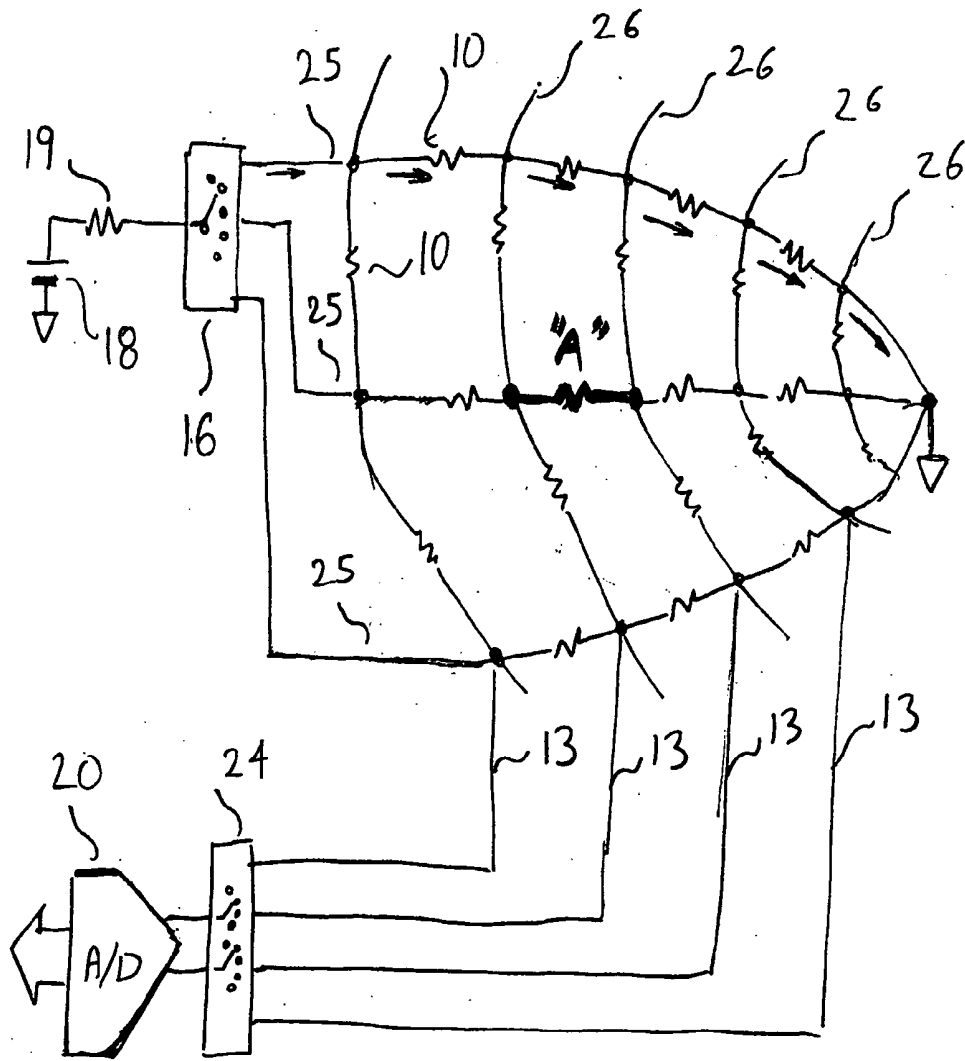

Fig 6

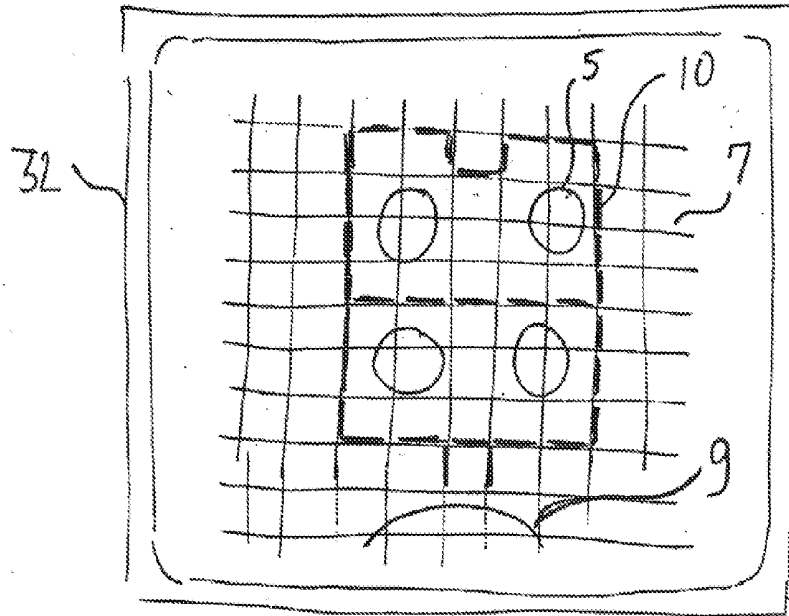

FIG. 7

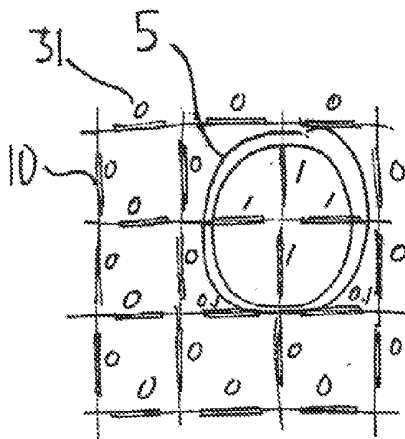

FIG. 8A

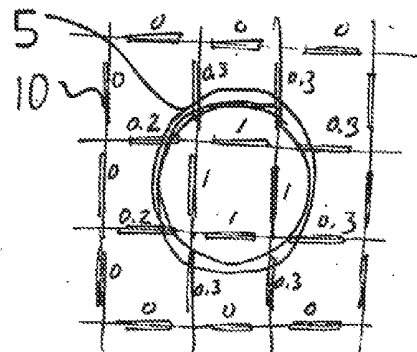

FIG. 8B

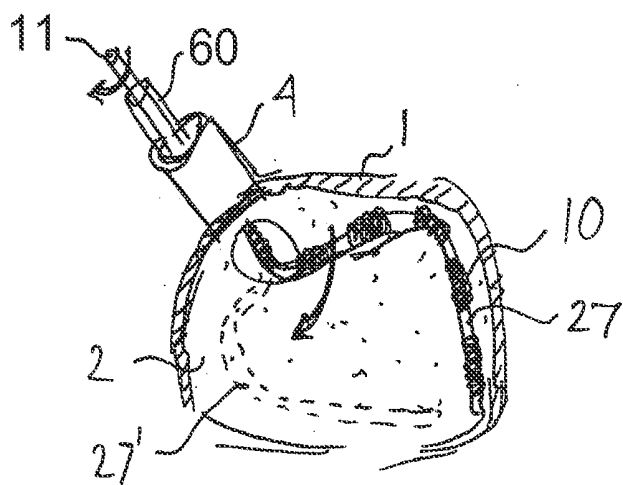

Fig 9

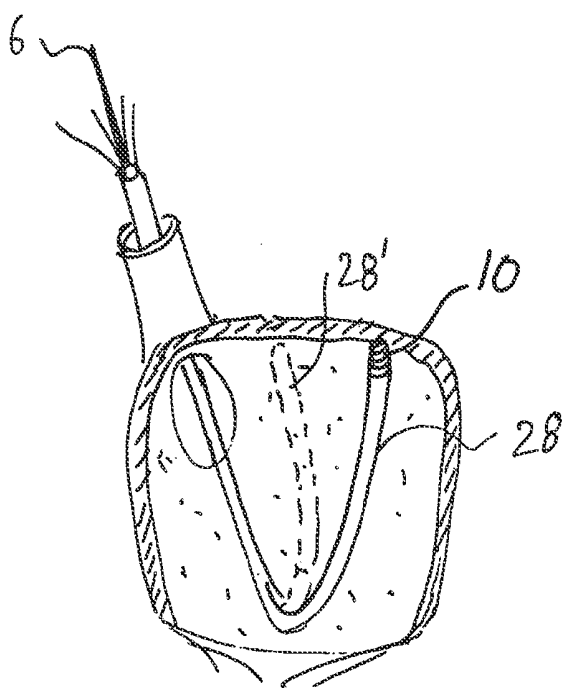

Fig 10

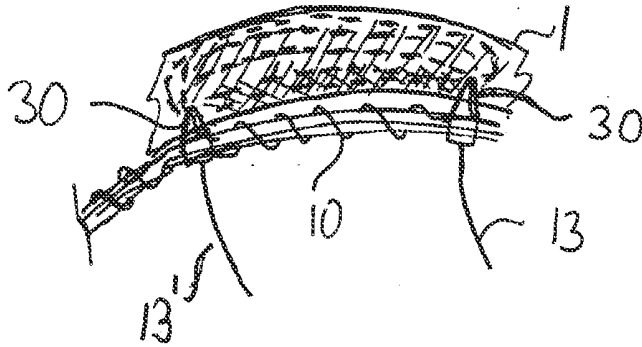

Fig 11

APPARATUS AND METHOD FOR INTRA-CARDIAC MAPPING AND ABLATION

BACKGROUND

[0001] 1. Technical Field

[0002] This disclosure generally relates to minimally invasive heart surgery, also known as percutaneous cardiac surgery and particularly relates to percutaneous mapping and ablation.

[0003] 2. Description of the Related Art

[0004] Atrial fibrillation is a well known disorder in which spurious electrical signals cause an irregular heart beat. The disorder has a well known cure known as the Maze procedure, in which a border is ablated around the sources of the spurious signals, typically in the left atrium but sometimes in the right atrium. The procedure is very commonly performed under direct vision, but difficult to perform percutaneously via a catheter because of the associated risk. Any error in navigation inside the heart can cause fatal damage. The key to a percutaneous procedure is mapping of the inside of the right and left atrium. Access to the right atrium is simple via the superior vena cava; the left atrium can be reached by i) perforating the transatrial septum, ii) via the aorta and the left ventricle or iii) via the pulmonary veins.

[0005] Prior approaches to map the inside of the atrium relied on electrical activity picked up from the atrium wall. These approaches require intimate electrical contact, not always possible because of scar tissue and deposits. These approaches may fail to accurately map the edges of the openings where the veins enter the atrium; information that is useful for correct placement of the ablation pattern. Other mapping methods, such as using an array of ultrasonic transducers, are not practical since such arrays typically will not fit through a catheter of a reasonable size (8-10 mm diameter). A superior mapping apparatus and method, that enables safe execution of the Maze and other intra-cardiac procedures is desirable.

[0006] A good survey article on the subject is: "Ablation of Atrial Fibrillation: Energy Sources and Navigation Tools: A survey" by Ruediger Becker and Wolfgang Schoels (J. of Electrocardiology, Vol 37, 2004, pp 55-61). The article includes an extensive bibliography.

BRIEF SUMMARY

[0007] Embodiments of an intra-cardiac mapping system are based on locating openings or ports and values through which blood flows in or out of the heart chambers. For many procedures, such as ablation to cure atrial fibrillation, accurately locating the pulmonary veins and the mitral valve allows performance of a Maze procedure. The openings, ports and valves may be located based on the convective cooling effect of the blood flow. The mapping can be performed by a catheter-deployed expandable net or a scanning catheter. The same net or catheter can also perform the ablation procedure.

[0008] In one embodiment, a method for intra-cardiac mapping comprises: introducing a plurality of flow sensors into an intra-cardiac cavity; locating points in a wall forming said cavity based on sensing blood flow; and mapping said walls of said cavity based on said points. The method for intra-cardiac mapping may include said blood flow being sensed by its convective cooling effect on a heated sensor. The method for intra-cardiac mapping may include said sensing being done by a steerable linear array. The method for intra-cardiac map-

ping may include said mapping being used for treating atrial fibrillation by RF ablation. The method for intra-cardiac mapping may include being used for treating atrial fibrillation by microwave ablation. The method for intra-cardiac mapping may include said mapping being used for treating atrial fibrillation by cryogenic ablation. The method for intra-cardiac mapping may include said mapping being used for treating atrial fibrillation by laser ablation. The method for intra-cardiac mapping may include said blood flow being sensed by the resistance change of a heated resistive wire.

[0009] In another embodiment, a method for intra-cardiac mapping comprises: introducing an expandable sensing mesh into said cavity via a catheter; using said mesh to locate openings in walls forming said cavity based on the convective heat transfer of blood flowing through said holes; and mapping inside of said cavity based on location of said openings. The method for intra-cardiac mapping may include said blood flow being sensed by its convective cooling effect on a heated sensor. The method for intra-cardiac mapping may include said sensing being done by a steerable linear array. The method for intra-cardiac mapping may include said mapping being used for treating atrial fibrillation by RF ablation. The method for intra-cardiac mapping may include said mapping being used for treating atrial fibrillation by microwave ablation. The method for intra-cardiac mapping may include said mapping being used for treating atrial fibrillation by laser ablation. The method for intra-cardiac mapping may include said blood flow being sensed by the resistance change of a heated resistive wire. The method for intra-cardiac mapping may include said mesh comprising small coils of nickel wire wound on a mesh of a flexible insulator. The method for intra-cardiac mapping may include an electronic switch used to minimize the number of electrical wires passing through said catheter.

[0010] In yet another embodiment, a method for treating atrial fibrillation comprises: introducing at least one flow sensor into an intra-cardiac cavity; locating points in a wall forming said cavity based on sensing blood flow; mapping walls of said cavity based on said points; and ablating a pattern into walls of said cavity based on said mapping. The method for treating atrial fibrillation may include said blood flow being sensed by its convective cooling effect on a heated sensor. The method for treating atrial fibrillation may include said sensing being done by a steerable linear array. The method for treating atrial fibrillation may include said mapping being used for treating atrial fibrillation by RF ablation. The method for treating atrial fibrillation may include said mapping being used for treating atrial fibrillation by microwave ablation. The method for treating atrial fibrillation may include said mapping being used for treating atrial fibrillation by cryogenic ablation. The method for treating atrial fibrillation may include said mapping being used for treating atrial fibrillation by laser ablation. The method for treating atrial fibrillation may include said blood flow being sensed by the resistance change of a heated resistive wire. The method for treating atrial fibrillation may include said flow sensors also acting as electrodes for said ablation. The method for treating atrial fibrillation may include said flow sensor being based on temperature sensing and a same sensor being used to monitor temperature during said ablation. The method for treating atrial fibrillation may include said ablation being unipolar. The method for treating atrial fibrillation may include said

ablation being bipolar. The method for treating atrial fibrillation may include said ablated pattern being a Maze procedure.

BRIEF DESCRIPTION OF THE DRAWINGS

[0011] In the drawings, identical reference numbers identify similar elements or acts. The sizes and relative positions of elements in the drawings are not necessarily drawn to scale. For example, the shapes of various elements and angles are not drawn to scale, and some of these elements are arbitrarily enlarged and positioned to improve drawing legibility. Further, the particular shapes of the elements as drawn, are not intended to convey any information regarding the actual shape of the particular elements, and have been solely selected for ease of recognition in the drawings.

[0012] FIG. 1 is a cross sectional view of the heart showing the mapping mesh deployed in the left atrium.

[0013] FIG. 2 is a cross sectional view of the sensing device.

[0014] FIGS. 3A and 3B are isometric views of the mesh in both folded and expanded positions.

[0015] FIG. 4 is an isometric enlarged view of a portion of the mesh.

[0016] FIG. 5 is an electrical schematic of a mapping and ablation system.

[0017] FIG. 6 is an electrical schematic of a simplified mapping system.

[0018] FIG. 7 is a schematic view of the display console of the system.

[0019] FIGS. 8A and 8B are graphical views of a mapping that illustrate an interpolation principle.

[0020] FIG. 9 is a cross sectional view of an alternate embodiment, using mechanical or manual scanning in one axis.

[0021] FIG. 10 is a cross sectional view of an alternate embodiment, using mechanical scanning in two dimensions.

[0022] FIG. 11 shows the use of the invention for bipolar ablation.

DETAILED DESCRIPTION

[0023] FIG. 1 shows a sensing and ablation mesh 7 inserted into a left atrium 3 of a heart 1 according to one illustrated embodiment.

[0024] By way of example, the mesh 7 may be delivered via a catheter 60 inserted via a superior vena cava 4 and penetrating a transatrial septum from a right atrium 2 of the heart 1. The mesh 7 is communicatively coupled to the rest of the system, for example, by electrical wires 6.

[0025] Before any ablation takes place, the inside of the left atrium 3 is mapped in order to locate the openings or ports 8 leading to the pulmonary veins 5, as well as the mitral valve 9. A typical Maze procedure ablates a “fence” around openings or ports 8 to stop propagation of spurious electrical signals which cause the heart 1 to contract at the wrong times.

[0026] The mapping may locate some or all of the openings or ports 8 through which blood flows in and out of the left atrium 3, as the Maze procedure is mainly concerned with the location of these openings or ports 8. By the way of example, in the left atrium 3, the four openings or ports 8 leading to the pulmonary veins 5 as well as the mitral valve 9 may be located. The location of these openings or ports 8 may be based on the fact that the convective cooling effect of the blood is significant, and a slightly heated mesh 7 pressed

against the walls of the left and/or right atrium 3, 2 will be cooler at the areas which are spanning the openings or ports 8 carrying blood.

[0027] FIG. 2 shows the ablation mesh 7 covered by miniature heating and/or temperature sensing elements 10a-10c flow (collectively 10, only three illustrated in the figure). Each one of these elements 10a-10c comprises a few turns of a resistive wire, for example nickel wire, wound on an electrically insulated mesh. A low current is passed through each element 10, raising a temperature of the element 10 by about 1 degree C. above normal blood temperature. A first element 10b, which lies across an opening or port 8 of one of the pulmonary veins 5, will be cooled by blood flow. The other elements are against a wall 3 and hence do not lie across any of the openings or ports 8.

[0028] By identifying the relatively cooler elements 10a, 10c on the mesh 7, the location of the openings or ports 8 may be found.

[0029] This method does not require intimate contact with the wall 3, as the cooling effect is significant even a few millimeters away from the opening.

[0030] The same elements 10 can be used as ablation electrodes during an ablation stage. It was found that the power required to raise the temperature of the mesh 7 by a small but easily detectable amount is very small, on the order of 10-50 mW per element 10. If the elements 10 are made of a material that has a significant change in resistance with temperature, the temperature drop can be sensed by measuring a voltage across the element 10 when driven by a constant current. A good choice for element material is nickel wire, which is inert, highly resistive and has a significant temperature coefficient of resistance (about 0.6% per deg C). Since the resistance of the elements 10 is low (typically 0.1-1 ohm), the electrical noise is very low and temperature changes as low as 0.1 deg can be easily detected. For even higher detection sensitivity, the voltage waveform can be sampled in synchronization with the heart rate or the average voltage removed and only the change amplified. Such methods are referred to as “AC coupling”. A further refinement to reduce the electrical noise is to pass the signal through a digital band pass filter having a center frequency tracking the heart rate. To avoid any potential tissue damage, the temperature of the elements 10 of the mesh 7 is only slightly above the blood temperature, typically 0.1-3 degrees C. above blood temperature.

[0031] FIG. 3A shows the mesh 7 in a compressed configuration “A” and FIG. 3B shows the mesh 7 in an expanded configuration “B”. Since the mesh 7 has to fit into a catheter 60, the mesh 7 should be very flexible. Besides elements 10 discussed earlier, there is also a large number of leads 13 coming out of the mesh 7. Leads 13 can be loose, as shown in FIG. 3B, or may be bonded to the mesh 7. To avoid feeding a large number of wires all the way to an operating console, an electronic selector switch may be employed, which may, for example, be mounted in the catheter 60. This reduces the number of electrical wires from over 100 to about 10. The mesh 7 can be self-expanding (elastic) or balloon-expandable. Self expanding allows normal blood flow during the procedure. For balloon expandable devices, the expansion balloon should be removed before the mapping, to avoid blocking the flow of blood.

[0032] FIG. 4 shows the mesh 7 in more detail. Insulated longitudinal (i.e., parallel to catheter) wires 25 are crossed by cross wires 26. Each section of the mesh 7 is covered by a few turns of thin (0.05-0.2 mm) nickel wire 10 having leads 13.

The leads **13** can be regular thin copper wire. The longitudinal wires **25** can be stiffer than the cross wires **26**, therefore can be made self-expanding by incorporating a core **14** made of coiled flexible metal wire such as Nitinol. A metallic core may interfere with the ablation process at higher frequencies and can be replaced by simply making the longitudinal wires **25** of a polymeric material thicker than the cross wires **26**. The cross wires **26**, which may form rings around wires **25**, should be very flexible to compress into the catheter **60**. The cross wires **26** could incorporate a very thin wire or coiled up wire. Use of a flexible mesh **7** not only allows percutaneous delivery, but also permits the mesh **7** to follow the atrial volume change each heartbeat. The mesh **7** should stay in contact with or close to the atrial wall during the cardiac cycle, otherwise the measurement and the ablation may only be performed during parts of the cardiac cycle. The diameter of the longitudinal wires **25** and cross wires **26** are typically 0.2-1 mm. The mesh **7** may include about 10-20 longitudinal wires **25** and about 10-20 cross wires **26**. The insulation can be any polymeric material such as thin enamel or polymer coating. Practically any polymer can be used, as the maximum temperature it will be subject to, including during the ablation phase, is around 100 degrees C.

[0033] FIG. 5 shows an electrical system, according to one illustrated embodiment. The elements **10** may be resistive heaters wound on the mesh **7**. Each of the elements **10** is connected by electronic element switches **15** (typically FET or MOS-FET type) to a single pair of wires leading out of the body to a mode selection switch **17**. Element switches **15** are selected by de-multiplexer or selector **16**. The de-multiplexer or selector **16** is controlled by a small number of wires or even a single wire if data is sent in serial form, by a multiplexer **22**. Element switches **15** and de-multiplexer or selector **16** may be built into the catheter **60**, which may, for example, be located near the point of deployment of the mesh **7**. The element switches **15** have to carry significant power during the ablation phase.

[0034] The mode selection **17** selects between a mapping mode (position shown in the drawing) and an ablation mode (second position of switch). In the mapping mode, a current is created by a voltage source **18** and resistor **19** (e.g., forming a constant current source) and routed into a selected element **10** by the element switches **15**. For each measurement, the two element switches **15** that are connected to the scanned element **10** are in an enabled state (ON), the rest of the element switches being in a disabled state (OFF). The voltage drop across an element **10** is measured by an analog to digital (A/D) converter **20** and fed to a control computer **23**. For greater accuracy, four terminal sensing can be employed. In a preferred embodiment, the detection is AC coupled, therefore the DC voltage drops along the wires are of no consequence, and no four-terminal sensing is needed. For AC coupling, the control computer **23** includes a 0.5 Hz low pass filter implemented in software. The slight disadvantage of the AC coupled method approach is speed, as the low signal frequency (e.g., about 1 Hz), requires a few seconds per measurement. Other temperature sensors and/or approaches, such as thermistors or thermocouples, can be used in conjunction with the elements **10**. Mapping is achieved by turning on all of the elements **10** sequentially and measuring the temperature of each. A map is formed in the control computer **23** and the lower temperature spots on the mesh correspond to the openings or ports **8** leading to the veins or valves.

[0035] When the mode selection switch **17** is in the ablation mode, a generator **21** (e.g., Radio Frequency (RF)) is connected (e.g., sequentially) to selected elements **10** by the control computer **23** addressing the multiplexer **22** which controls the element switches **15** via the de-multiplexer selector **16**. The complete operation, including scanning and ablation, can be completed in less than 5 minutes. The configuration illustrated in FIG. 5 implies unipolar ablation; however bipolar ablation can be used as well and is discussed below. Clearly other sources of ablation can be used besides RF. Frequencies from DC to microwaves can be used, as well as delivery of laser power via optical fibers or cryogenics via thin tubes. For laser ablation element switches **15** are optical switches, while for cryogenic ablation the element switches **15** are valves.

[0036] During ablation it is desirable to monitor the temperature of the mode selection switch **17** to the mapping position several times during the ablation procedure. The measured temperatures can be displayed on a display **32** (FIG. 7). RF ablation is typically performed at frequencies of 100 KHz-1 MHz and power levels which depend on the size of the elements **10**, but can be as high as 100 W. Various RF ablation techniques and equipment are well known in the art.

[0037] FIG. 6 shows an embodiment in which the mapping system is separate from the ablation system. In this system, the mesh **7** has very few connecting wires. As illustrated, each longitudinal wire **25** has a single output wire and each cross wire **26** has a single output wire **13**. For a 10x10 mesh **7** with 100 nodes, only twenty-one wires are needed (ten plus ten plus ground wire), instead of two hundred wires. This allows all wires to be brought directly out of the catheter **60**. This also allows placement of selector switches **16** and **24** together with the control system. For example, if the element marked as "A" is selected; a current is selected to run through the longitudinal wire **25** which includes element A. The voltage drop is sensed by the two circumferential wires **13** that connect directly to A. Since no current flows in the other elements at the time of measurement, the voltage drop is only caused by element A. It is sensed by A/D converter **20** via double pole selector **24**.

[0038] After a map is established, it is displayed on a display screen **32** as shown in FIG. 7. The surgeon can select which elements **10** will cause tissue ablation in the atrium. The pattern formed is along the line of the standard Maze procedure. The location of the pulmonary veins **5** and the mitral valve **9** is inferred from the temperature data and drawn on the display screen.

[0039] FIGS. 8A and 8B demonstrate the principle of accurate location of the veins and valves even if the grid is relatively coarse. The exact location can be interpolated based on the fact that when only part of the element **10** is exposed to the blood flow. By the way of example, if the temperature of the mesh **7** is 1 degree C. above blood temperature and equals the blood temperature under normal blood flow (this was experimentally verified), the temperatures of a group of elements **10** will be as shown in FIG. 8A when aligned with the opening or port **8** of vein **5**. The number near each element **10** is the temperature drop. When moved, some of the elements **10** will only be partially positioned in the flow path under vein **5**, as shown by FIG. 8B. The temperatures of those elements **10** will be between 0 and 1 degree above blood temperature. The exact temperature drop between 0 to 1 corresponds with the exact shift. This allows accurate determination of the location and size of each opening or port **8**, data used by the control

computer 23 to draw the map shown in FIG. 7. A grid spacing of 10 mm allows about 1 mm accuracy.

[0040] An alternative to a full mesh is a partial mesh, or even a single sensor, that is mechanically scanned across the area to be mapped. FIG. 9 shows a linear sensor array 27 pushed into the atrium 2 via vein 4 by the catheter 60. The linear sensor array 27 has a linear array of elements 10 similar to those used in the full mesh 7. After a linear mapping is performed the linear sensor array 27 is rotated (as shown by broken line 27') a small amount (10-20 degrees) by stem 11 (similar to electrical wires 6) and a new scan is performed. The same procedures previously described may be used for ablation.

[0041] FIG. 10 shows the use of a single steerable catheter 28 as a mapping and ablation tool. Steerable catheters are controlled remotely by mechanical, magnetic, hydraulic or other means. A steerable catheter 28 can be used to scan the inside of the atrium 3 by bending, as shown in broken line 28'. The location is monitored by external or internal sensors. A position of a tip of the steerable catheter 28 can also be monitored by fluoroscopy. The catheter tip contains a heating and/or ablation element 10. Steerable catheters 28 may advantageously carry a wide range of ablation systems, since only one connection and one point are needed.

[0042] A full mesh trades a higher complexity for better speed and accuracy when compared to linear arrays or single point scanning.

[0043] The previous examples were of unipolar ablation, with the ablation current returning to ground via the patient's body. The disclosed system can also be used for bipolar ablation as shown in FIG. 11. In unipolar ablation the same voltage is connected to both leads 13 and 13' of an element 10. In bipolar ablation the voltage is connected to lead 13 while the other end, 13', is grounded. It is important that the element 10 will be of sufficient resistance to cause most of the ablation current to flow through heart tissue 1. Electrodes 30 make contact with tissue 1 while the wire used in the element 10 is covered by an insulator. The advantage of bipolar ablation is better control of ablation depth. Typical ablation temperatures are 60-80 degrees C. At a higher temperature the tissue 1 becomes less conductive, forcing the ablation current to seek a new path. This promotes full ablation of the tissue 1. The element 10 can also be designed to assist ablation by creating heat when ablation voltage is applied across it.

[0044] One possible advantage of at least some of the presently disclosed embodiments over electrical potential mapping methods is that the presently disclosed embodiments do not require perfect contact between the mesh 7 and the tissue 1. The presently disclosed embodiments may also advantageously be less sensitive to the surface properties of the tissue, such as scar tissue or plaque.

[0045] If the mesh is separated from the tissue by a thin layer of blood, both the temperature sensing and the ablation functions of the presently disclosed embodiments will still function properly.

[0046] The word "element" in this disclosure has to be interpreted in a broad sense as any element capable of sensing blood flow. Clearly the elements do not need to be heaters, as cooling elements will work equally well. If a material is injected into the blood flow, any sensor capable of detecting this material can be used to detect blood flow. By the way of example, if the blood is cooled or warmed slightly before returning to the heart only temperatures sensors are needed. Since temperature differences as low as 0.1 degree C. can be

detected reliably, it is fairly simple to heat or cool the blood slightly before it returns to the heart (even by a simple external pad).

[0047] The above description of illustrated embodiments, including what is described in the Abstract, is not intended to be exhaustive or to limit the embodiments to the precise forms disclosed. Although specific embodiments of and examples are described herein for illustrative purposes, various equivalent modifications can be made without departing from the spirit and scope of the disclosure, as will be recognized by those skilled in the relevant art.

[0048] The various embodiments described above can be combined to provide further embodiments. Aspects of the embodiments can be modified, if necessary, to employ systems, circuits and concepts of the various patents, applications and publications to provide yet further embodiments.

[0049] These and other changes can be made to the embodiments in light of the above-detailed description. In general, in the following claims, the terms used should not be construed to limit the claims to the specific embodiments disclosed in the specification and the claims, but should be construed to include all possible embodiments along with the full scope of equivalents to which such claims are entitled. Accordingly, the claims are not limited by the disclosure.

1. (canceled)

2. A method executed by a control computer of a system, the system including an array of elements configured to be introduced into an intra-cardiac cavity, at least one of the elements configured at least to sense temperature, the control computer coupled to the array of elements, and the method comprising:

- locating points on a wall of the intra-cardiac cavity based on sensing blood flow with the elements;
- mapping the wall of the intra-cardiac cavity based on the located points to form a map presented by a display;
- updating the map while ablating a pattern into the wall of the intra-cardiac cavity with at least some of the elements; and
- monitoring, with at least one of the at least one of the elements, temperature during each of the locating and the ablating.

3. The method of claim 2, wherein the sensing blood flow with the elements comprises a sensing of temperature with the elements.

4. The method of claim 2, wherein each of the elements is responsive to convective heat transfer by the blood flow, and wherein the method further comprises providing a visual representation of one or more regions of the wall of the intra-cardiac cavity concurrently with each of one or more ports in a surface of the wall of the intra-cardiac cavity with respect to the one or more regions based at least on the sensed blood flow.

5. The method of claim 2, further comprising switching between a mapping mode, in which the mapping is performed, and an ablation mode in which the ablating is performed.

6. The method of claim 5, further comprising repeatedly switching between the mapping mode and the ablation mode during the ablating.

7. The method of claim 4, further comprising including the visual representation in the map presented by the display.

8. The method of claim 7, further comprising updating the map based on a repositioning of the array of elements in the intra-cardiac cavity.

9. The method of claim 2, wherein the sensing blood flow includes receiving signals that are indicative of convective heat transfer by the blood flow.

10. The method of claim 4, wherein the ablating includes providing current to at least one electrode of the at least some of the elements that is proximate to one of the one or more ports in the surface of the wall of the intra-cardiac cavity, wherein the one of the one or more ports is provided by a port of a pulmonary vein in the surface of the wall of the intra-cardiac cavity.

11. The method of claim 2, wherein the elements are arranged on a structure of the system, and the structure is expandable between a compressed configuration and an expanded configuration, and wherein the method further comprises percutaneously delivering the elements to the intra-cardiac cavity in the compressed configuration.

12. The method of claim 11, further comprising expanding the structure into the expanded configuration within the intra-cardiac cavity.

13. The method of claim 2, wherein the pattern is in accordance with a Maze procedure surrounding a port in a surface of the wall of the intra-cardiac cavity.

14. The method of claim 4, further comprising causing selected ones of the elements to ablate the surface of the wall of the intra-cardiac cavity at a location determined based at least on the visual representation, the determined location

located on the surface away from a respective location on the surface of the tissue wall interrupted by each of the one or more ports.

15. The method of claim 4, wherein the visual representation specifies a size of each port of the one or more ports, and the method further comprises causing selected ones of the elements to ablate the surface of the wall of the intra-cardiac cavity at a location determined based at least in part on the size of each port of the one or more ports specified by the visual representation, the determined location located on the surface away from each of the one or more ports.

16. The method of claim 4, further comprising causing selected ones of the elements to ablate the surface of the wall of the intra-cardiac cavity at a location other than a location of each of the one or more ports in the surface of the wall of the intra-cardiac cavity.

17. The method of claim 2, wherein the ablating includes bipolar ablation.

18. The method of claim 2, further comprising determining a size of a port in the wall of the intra-cardiac cavity based at least in part on temperature sensed by one or more of the elements.

19. The method of claim 2, further comprising determining a location of a port in the wall of the intra-cardiac cavity based at least in part on temperature sensed by one or more of the elements.

* * * * *

专利名称(译)	用于心脏内映射和消融的装置和方法		
公开(公告)号	US20150126993A1	公开(公告)日	2015-05-07
申请号	US14/546542	申请日	2014-11-18
[标]申请(专利权)人(译)	卡尔蒂姆公司		
申请(专利权)人(译)	KARDIUM INC.		
当前申请(专利权)人(译)	KARDIUM INC.		
[标]发明人	GELBART DANIEL LICHTENSTEIN SAMUEL VICTOR		
发明人	GELBART, DANIEL LICHTENSTEIN, SAMUEL VICTOR		
IPC分类号	A61B18/14 A61B19/00 A61B5/029 A61B5/00 A61B18/10 A61B5/028		
CPC分类号	A61B18/1492 A61B19/50 A61B5/028 A61B5/029 A61B5/6853 A61B19/56 A61B18/18 A61B18/20 A61B2018/0022 A61B2018/00577 A61B2018/00642 A61B2018/00714 A61B2018/00791 A61B2018/ /0212 A61B2018/0237 A61B2018/1407 A61B2018/00351 A61B2019/564 A61B18/10 A61B34/10 A61B34/25 A61B2034/254 A61B2562/046		
其他公开文献	US9119634		
外部链接	Espacenet USPTO		

摘要(译)

心内标测系统基于定位血液流入或流出心腔的端口。对于许多手术，例如消融治疗心房颤动，准确定位肺静脉和二尖瓣允许执行迷宫手术。端口和阀门的位置基于使用血流的对流冷却效果。可以通过导管部署的可扩展网或扫描导管来执行映射。相同的网或导管也可以执行消融手术。

