



(19) **United States**

(12) **Patent Application Publication**
Kehr et al.

(10) **Pub. No.: US 2013/0218588 A1**

(43) **Pub. Date: Aug. 22, 2013**

(54) **METHOD, APPARATUS, AND OPERATING SYSTEM FOR REAL-TIME MONITORING AND MANAGEMENT OF PATIENTS' HEALTH STATUS AND MEDICAL TREATMENT REGIMENS**

(71) Applicant: **Madrigal Health, LLC, (US)**

(72) Inventors: **Bruce A. Kehr, Potomac, MD (US); Robert H. Benson, Bethesda, MD (US); Evan Sohn, New York, NY (US); James E. Starnes, Crownsville, MD (US); David Maurer, Randolph, NJ (US); Davin Stowell, New York, NY (US); Dean Chapman, Brooklym, NY (US); David Farrage, Weehawken, NJ (US); Irwin D. Baumel, Delray Beach, FL (US); David S. Stempler, Potomac, MD (US)**

(73) Assignee: **Madrigal Health, LLC, Ft. Lauderdale, FL (US)**

(21) Appl. No.: **13/841,285**

(22) Filed: **Mar. 15, 2013**

Related U.S. Application Data

(63) Continuation of application No. 10/492,710, filed on Aug. 5, 2005, filed as application No. PCT/US98/03933 on Mar. 6, 1998.

(30) Foreign Application Priority Data

Mar. 7, 1997	(US)	60/040128
Apr. 18, 1997	(US)	60/044472
Jul. 1, 1997	(US)	60/051389
Sep. 8, 1997	(US)	08/924917
Oct. 22, 1997	(US)	08/955952
Dec. 22, 1997	(US)	60/068473

Publication Classification

(51) Int. Cl.	
G06F 19/00	(2006.01)
(52) U.S. Cl.	
CPC	G06F 19/3406 (2013.01)
USPC	705/2

(57) ABSTRACT

A medical monitoring device, operating system, and method are provided for managing administration of medical treatment regimens for treating a patient's medical conditions. The device stores information relating to administered medical treatment regimens, including medication schedule data, treatment data, patient query data, patient response data, and interactively provides information to the patient and health care providers. A method and apparatus for performing real-time monitoring of a patient's health status using the medical monitoring device are also provided. Various aspects of the patient's treatment regimens are modified accordingly. The medical monitoring device further analyzes monitored data in view of predefined criteria, and may promptly communicate information concerning the patient's health status and treatment progress to remote devices that notify health care providers, and may modify the patient's treatment regimens based on results of the analysis.

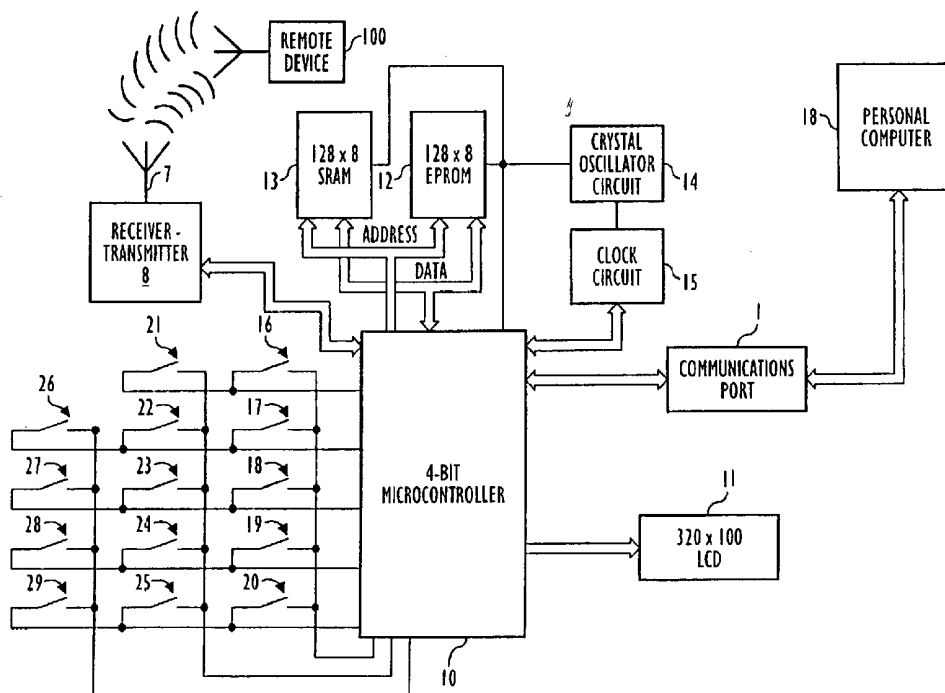

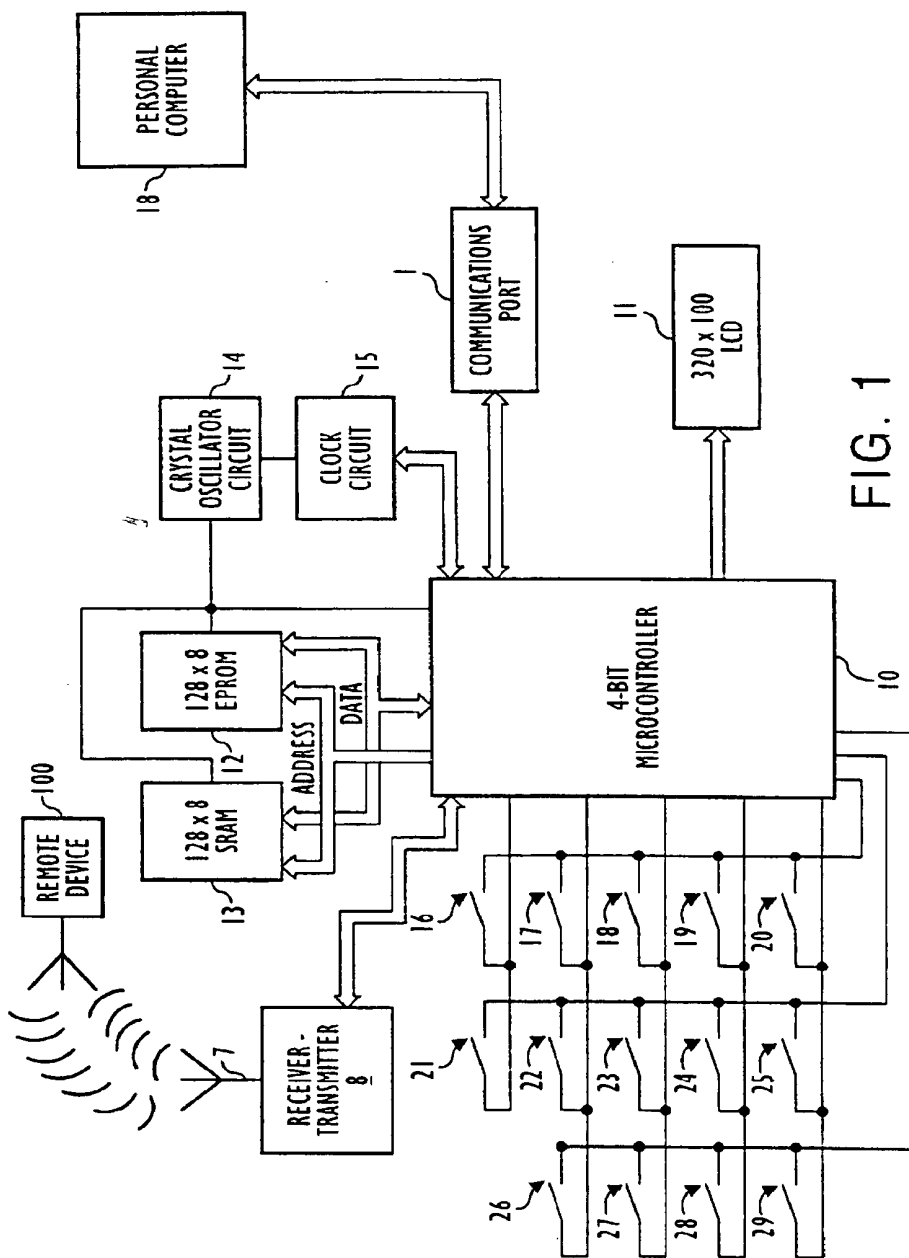

FIG. 1

FIG. 2(a)

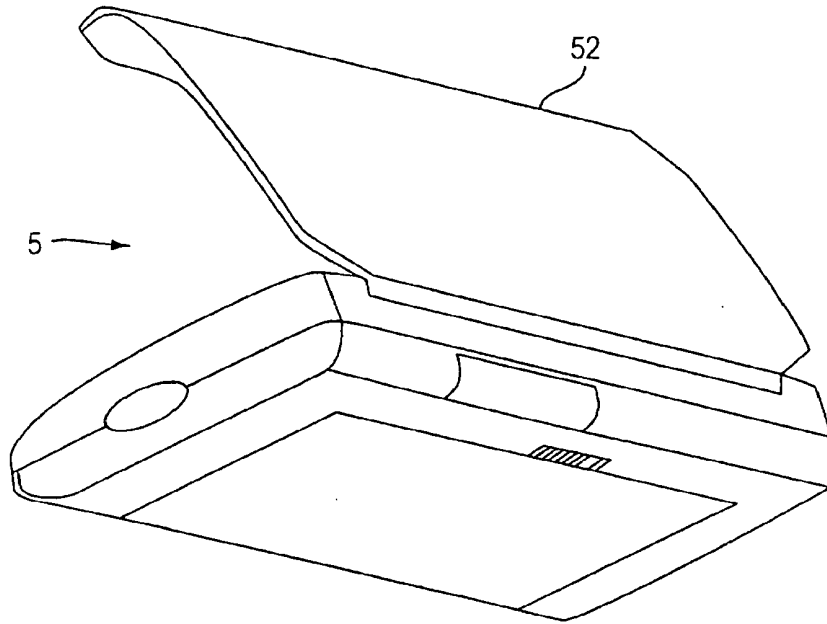

FIG. 2(b)

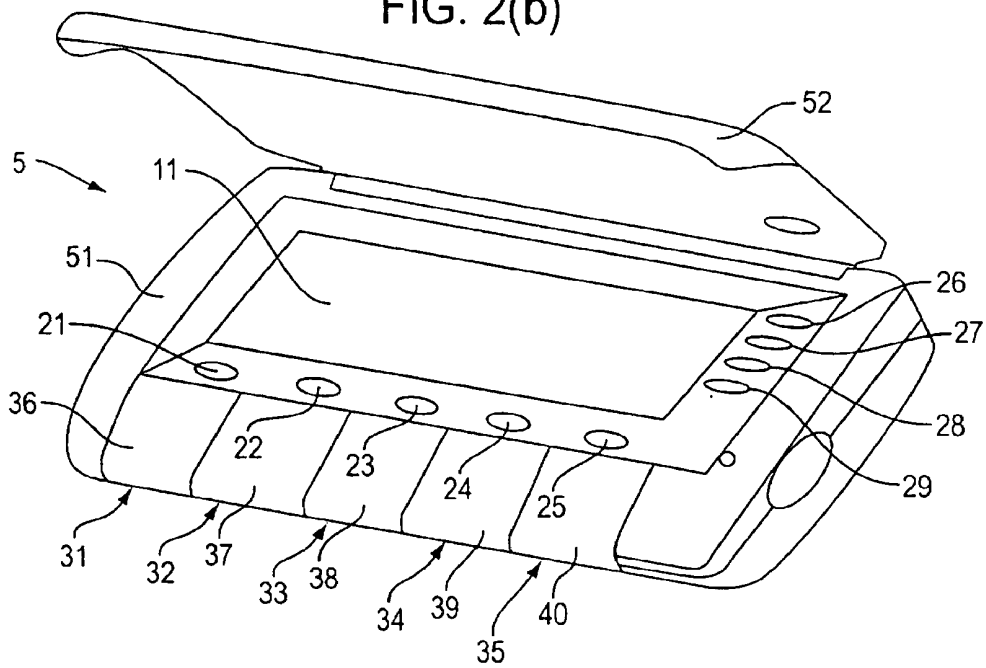
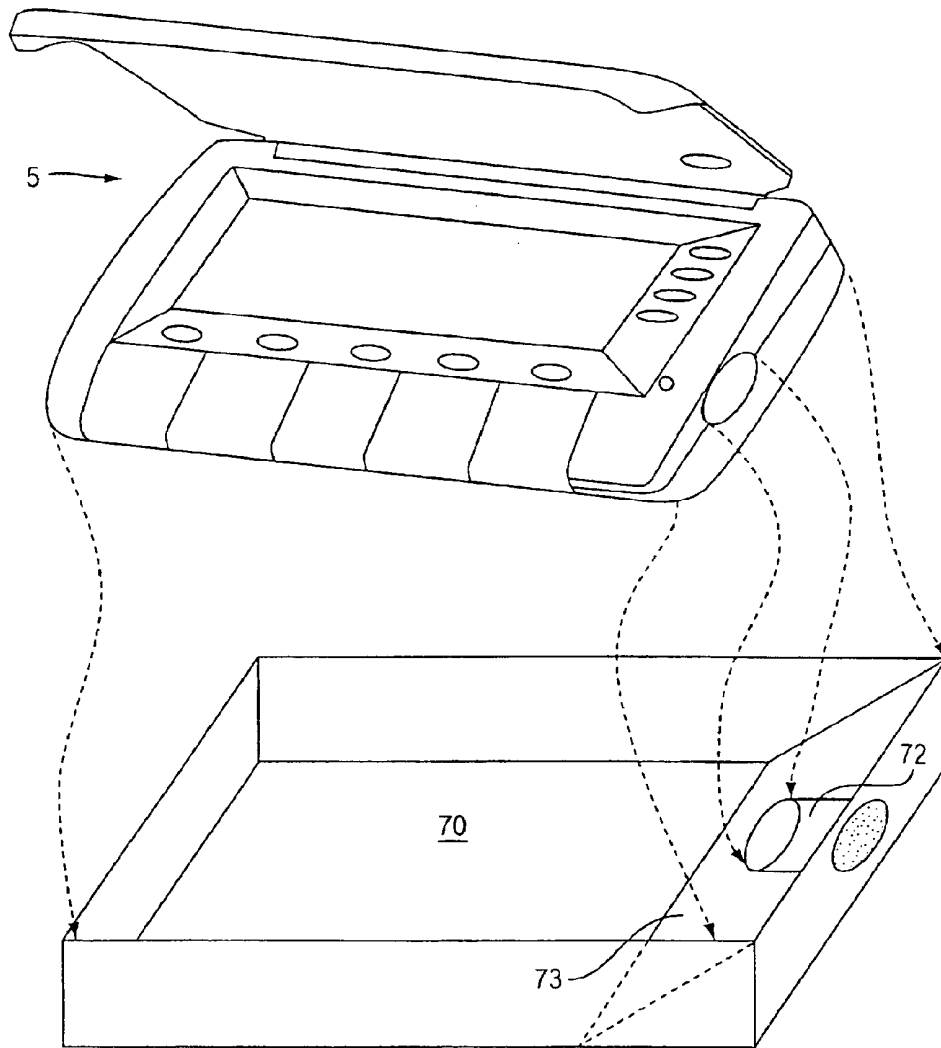

FIG. 3



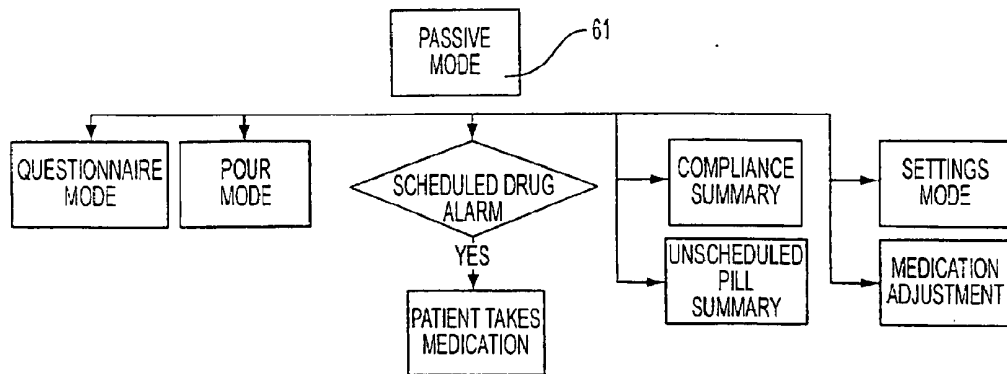

FIG. 4

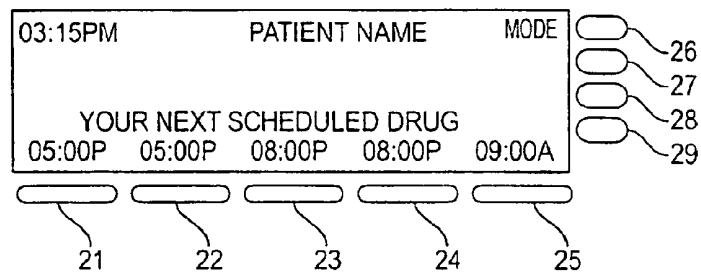

FIG. 5

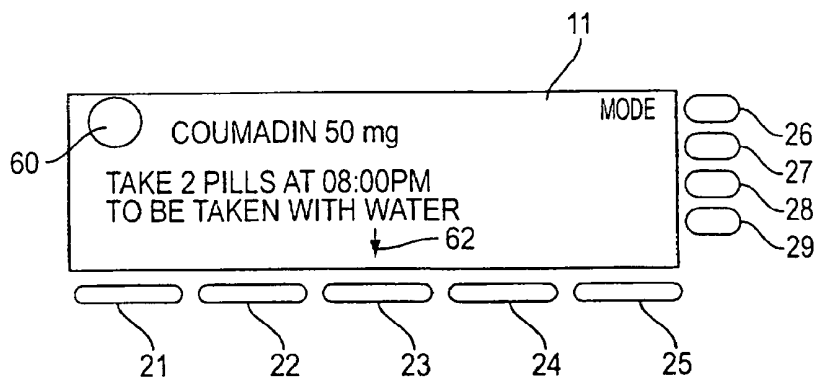

FIG. 6(a)

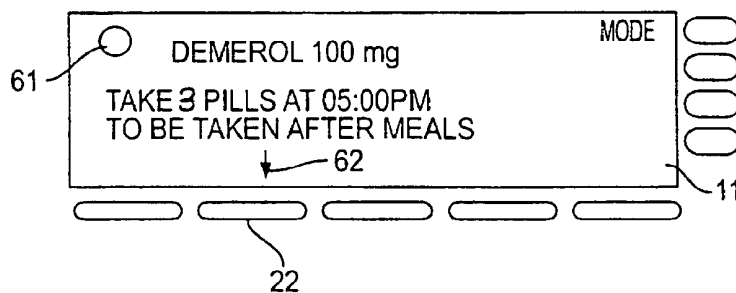

FIG. 6(b)

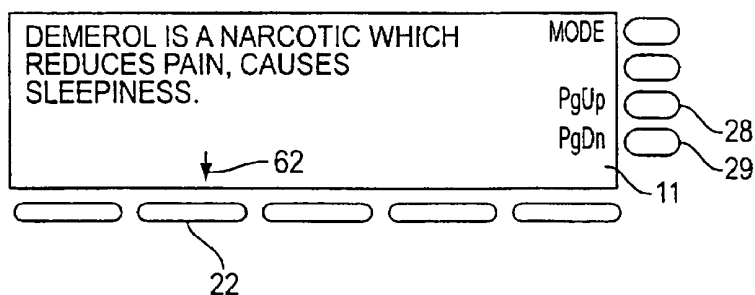

FIG. 6(c)

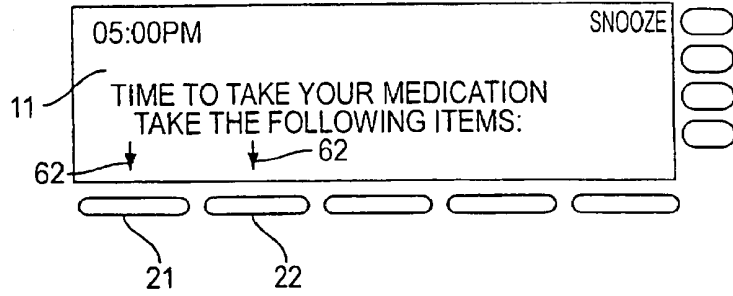

FIG. 7(a)

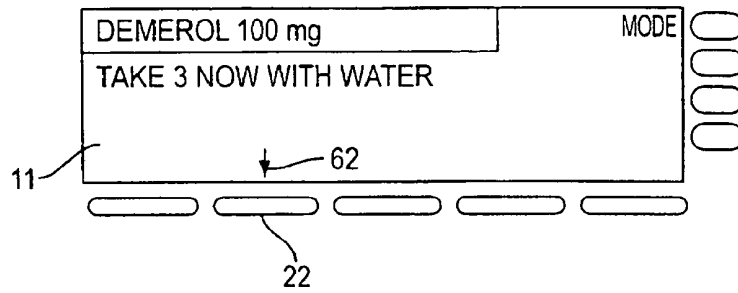

FIG. 7(b)

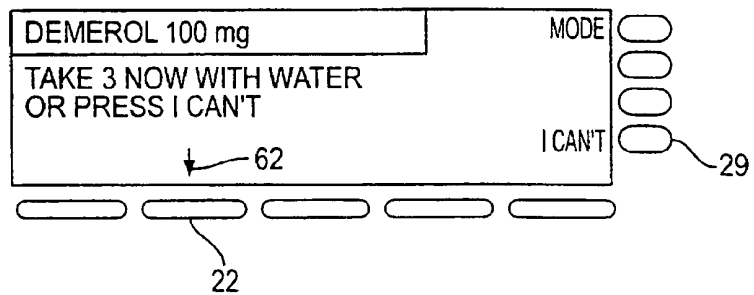

FIG. 7(c)

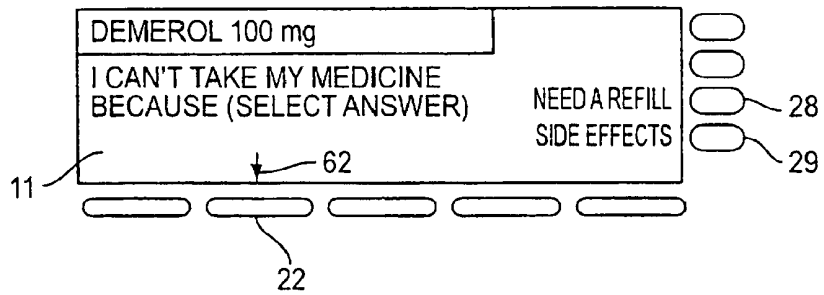

FIG. 7(d)

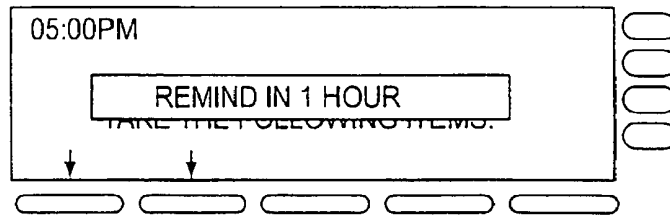

FIG. 7(e)

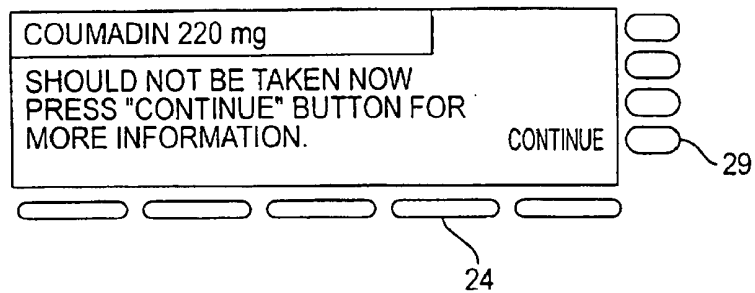

FIG. 8(a)

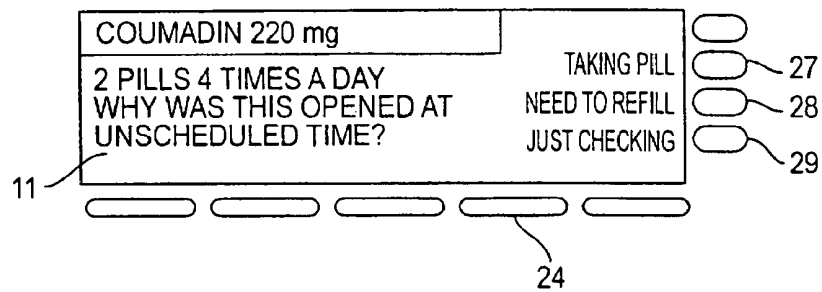

FIG. 8(b)

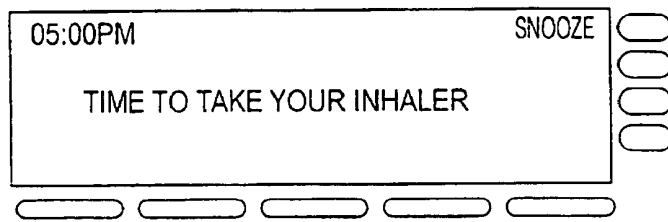

FIG. 9(a)

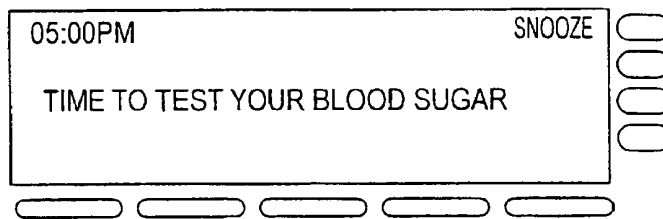

FIG. 9(b)

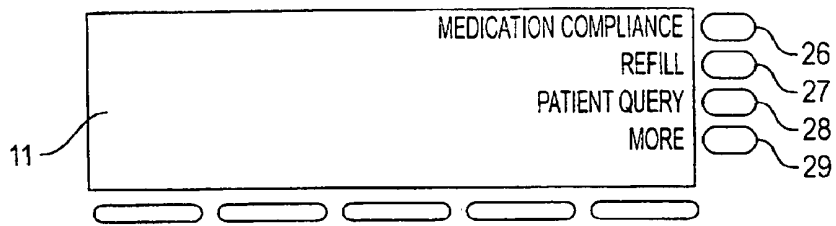

FIG. 10(a)

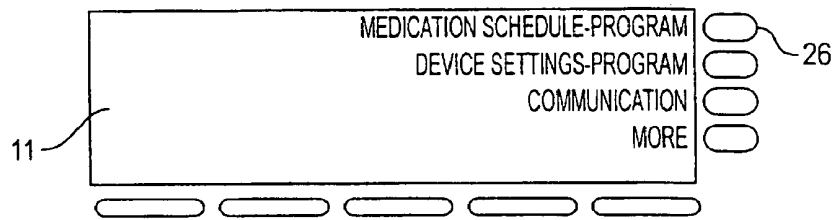

FIG. 10(b)

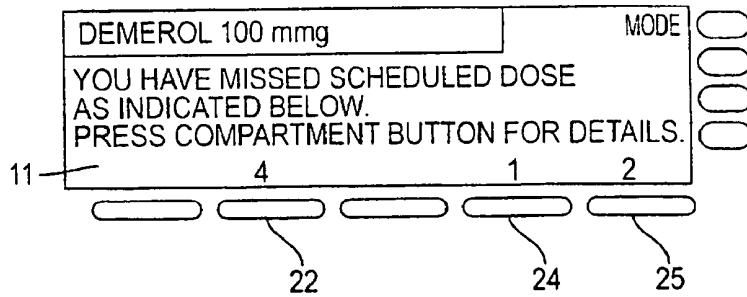

FIG. 11(a)

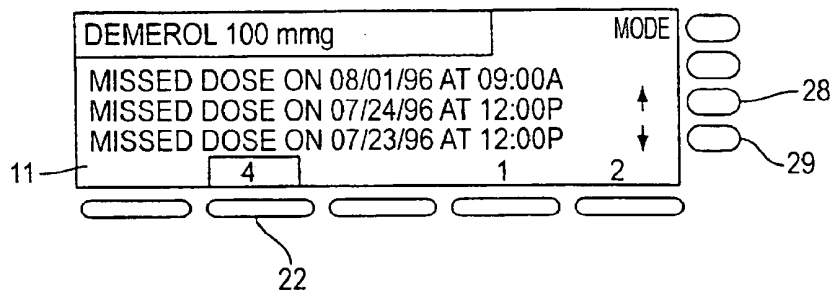

FIG. 11(b)

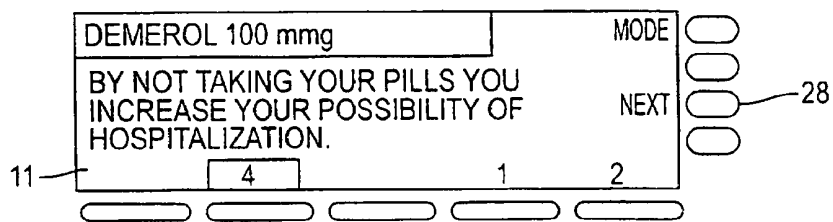

FIG. 11(c)

11

QUESTIONNAIRE	YES	<input type="radio"/>
ARE YOU READY TO ANSWER SOME QUESTIONS	NO	<input type="radio"/>

FIG. 12(a)

11

WAKING UP WITH SHORTNESS OF BREATH?	MILD	<input type="radio"/>
	MODERATE	<input type="radio"/>
	SEVERE	<input type="radio"/>
	NONE	<input type="radio"/>

FIG. 12(b)

11

QUESTIONNAIRE-GENERAL HEALTH	BETTER	<input type="radio"/>
ARE YOU FEELING...	WORSE	<input type="radio"/>
	SAME	<input type="radio"/>
	DON'T KNOW	<input type="radio"/>

FIG. 12(c)

11

QUESTIONNAIRE-GENERAL HEALTH	NONE	<input type="radio"/>
WEAKNESS,FATIGUE...	MILD	<input type="radio"/>
	MODERATE	<input type="radio"/>
	SEVERE	<input type="radio"/>

FIG. 12(d)

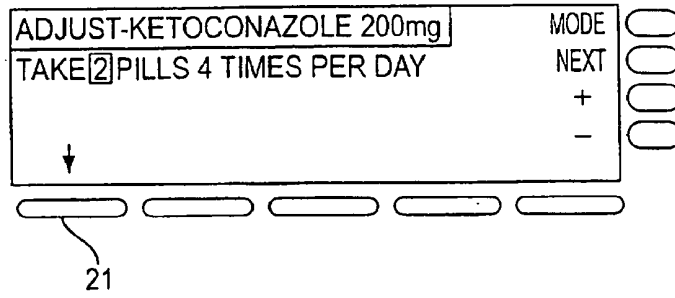

FIG. 13(a)

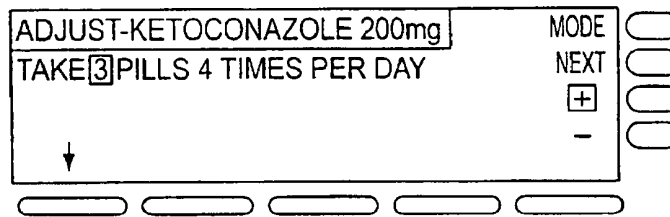

FIG. 13(b)

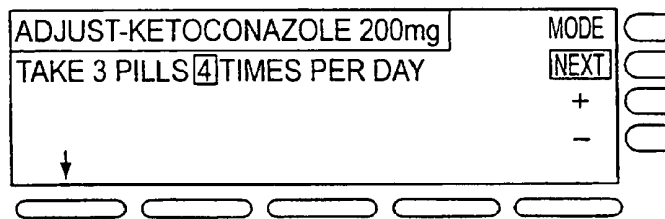

FIG. 13(c)

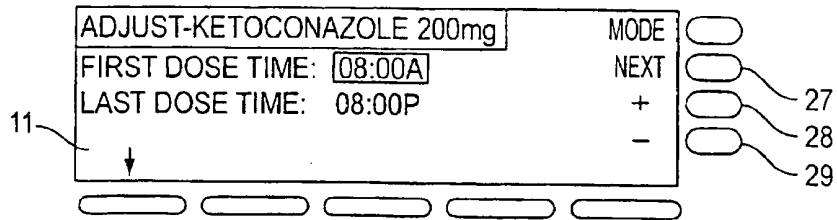

FIG. 13(d)

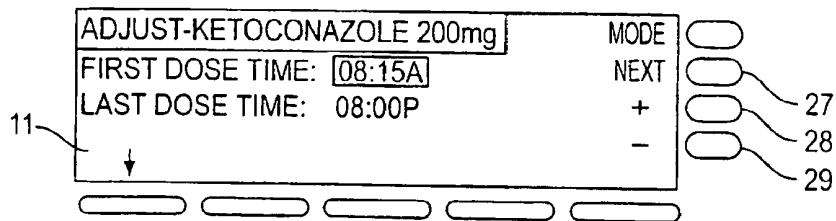

FIG. 13(e)

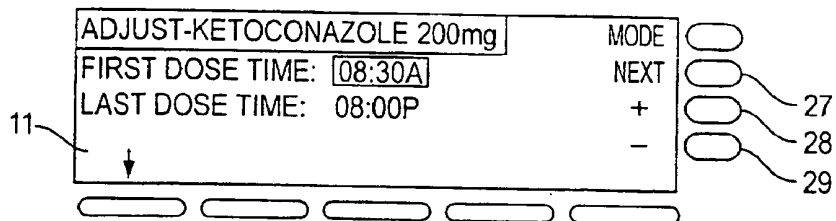

FIG. 13(f)

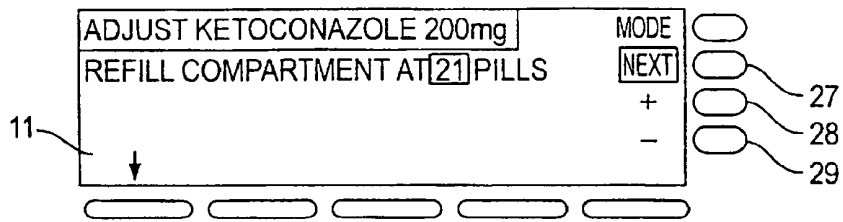

FIG. 13(g)

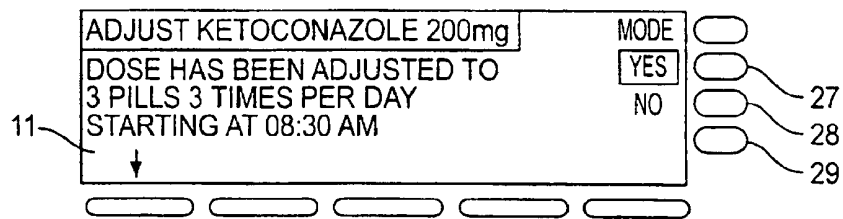

FIG. 13(h)

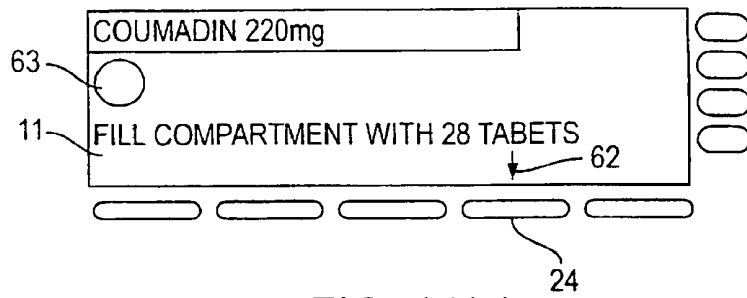

FIG. 14(a)

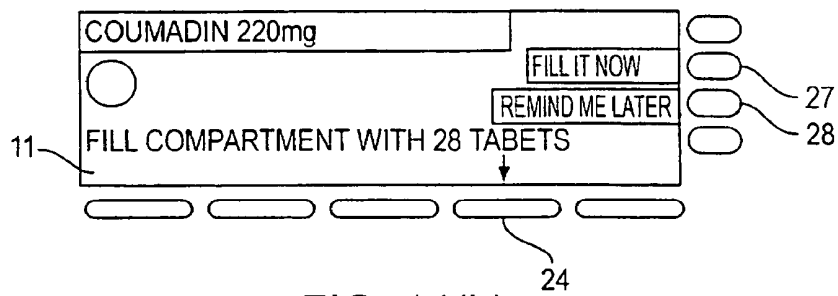

FIG. 14(b)

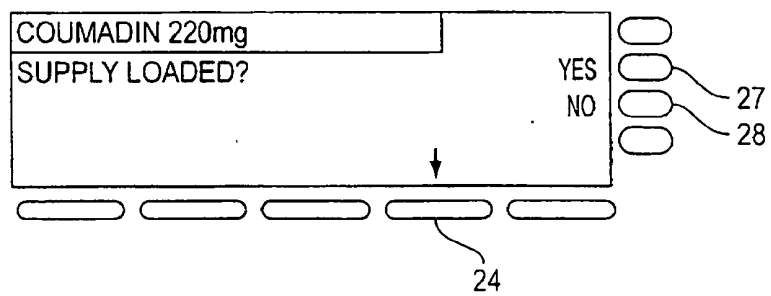

FIG. 14(c)

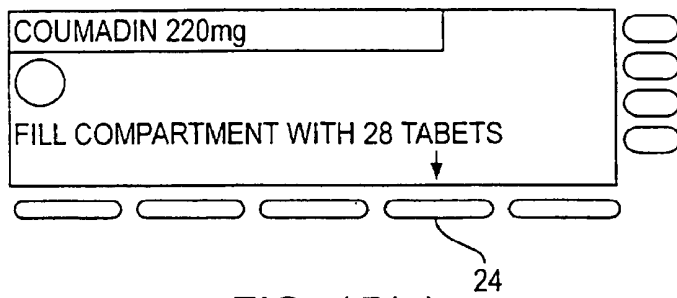

FIG. 15(a)

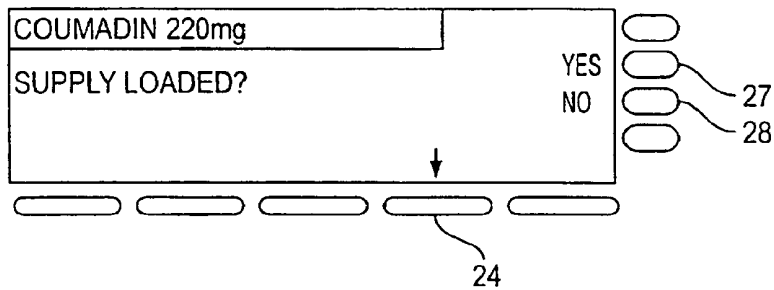

FIG. 15(b)

FIG. 16

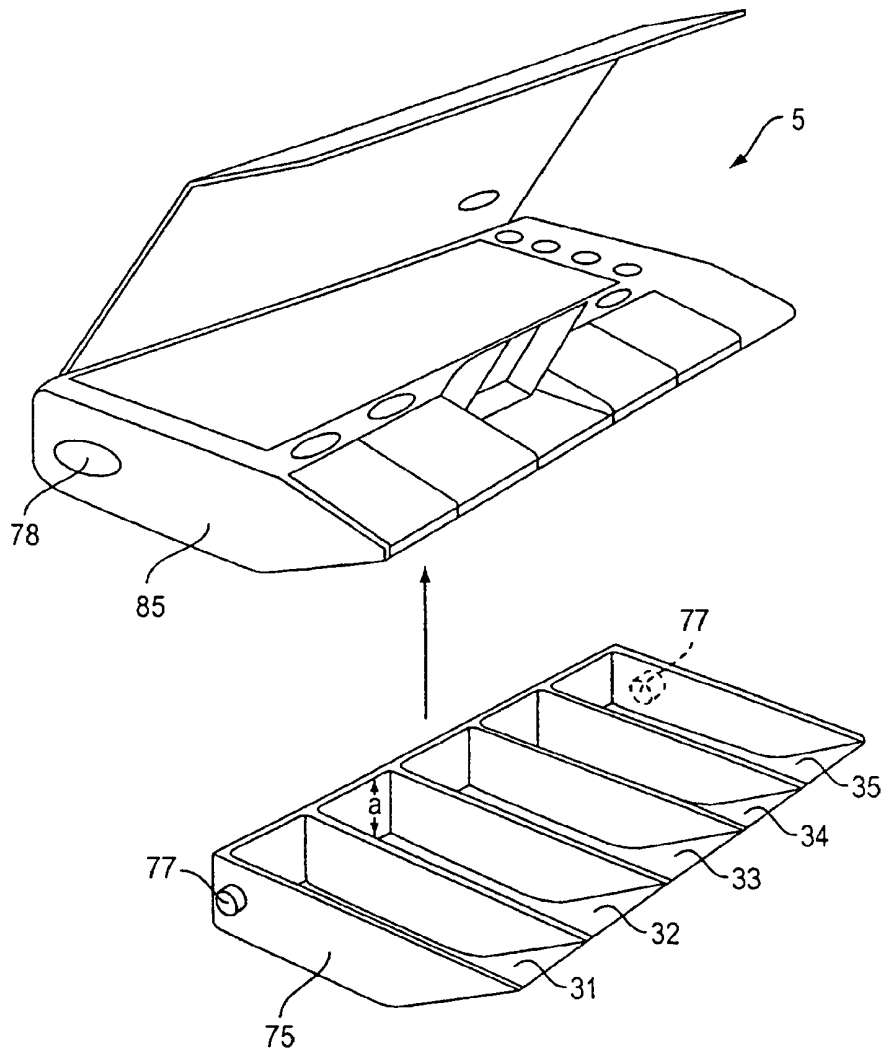

FIG. 17

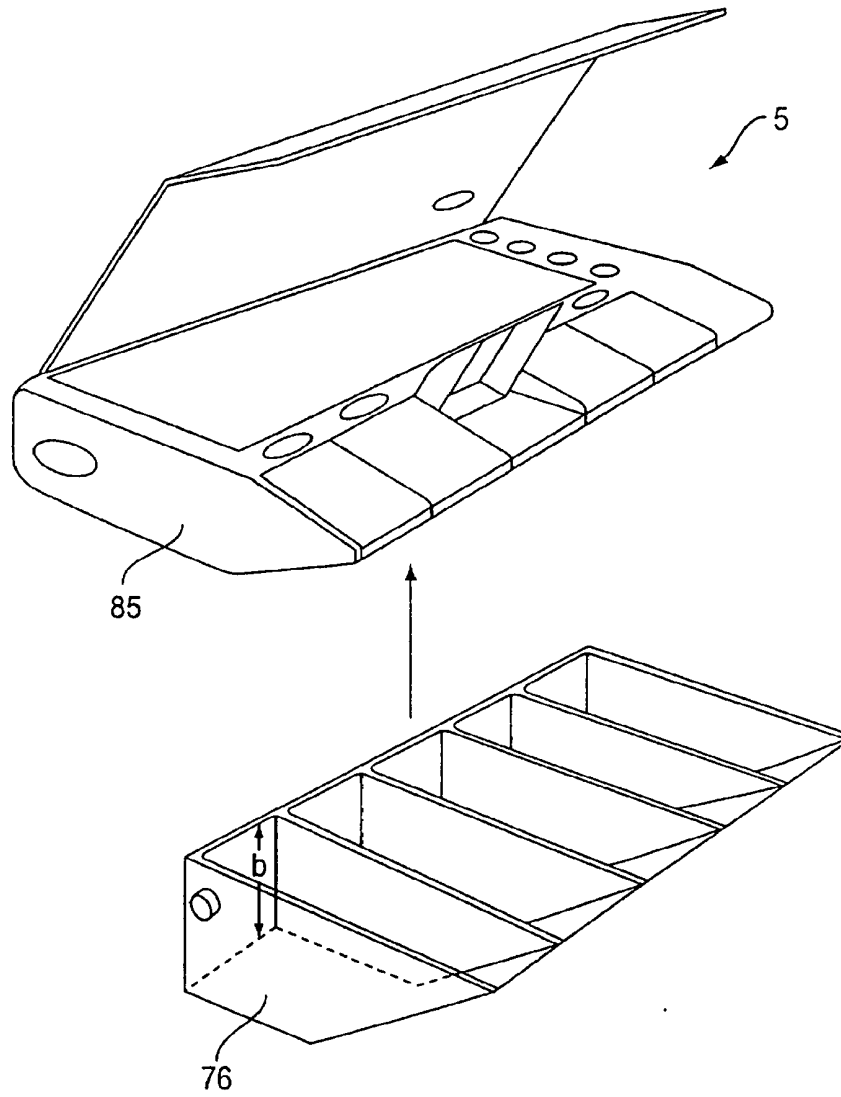

FIG. 18

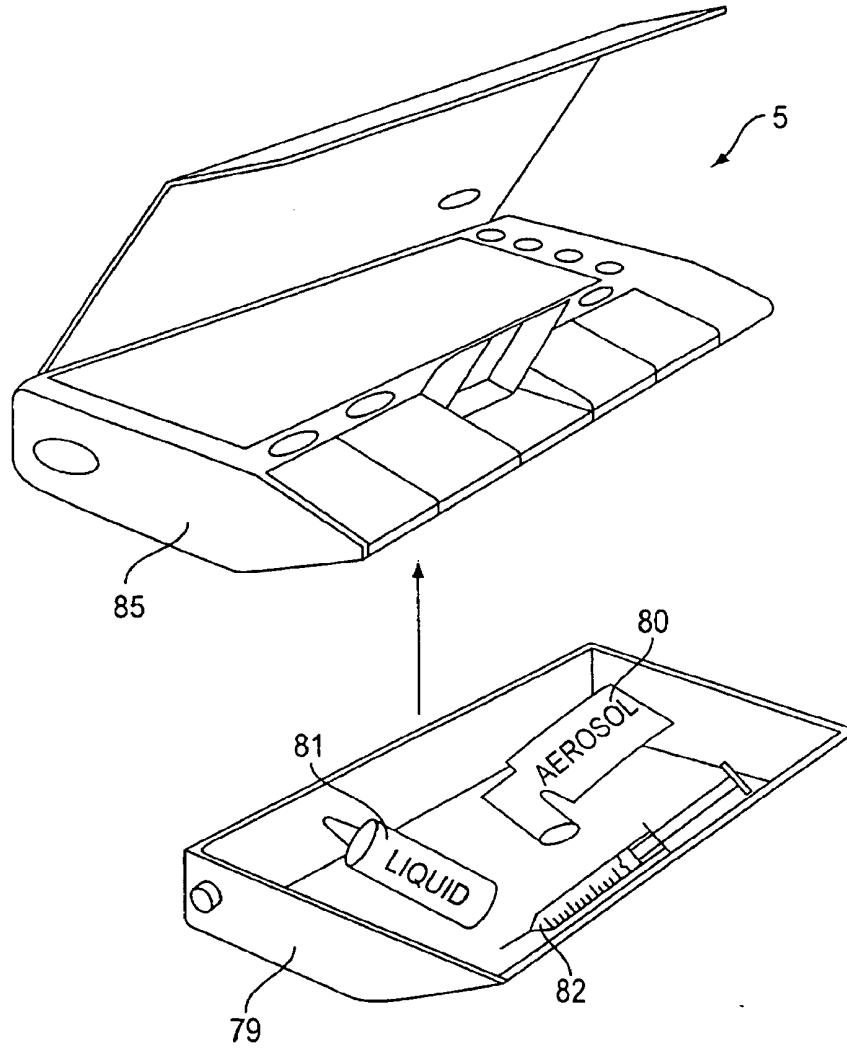

FIG. 19

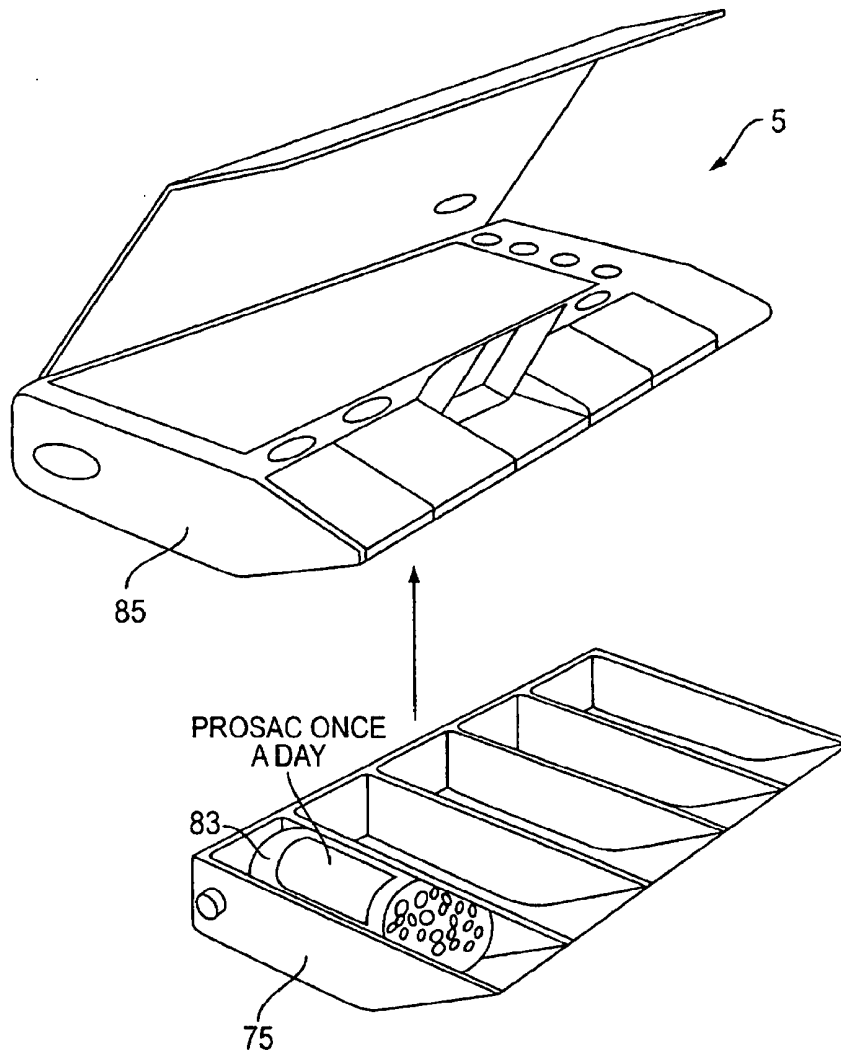

FIG. 20

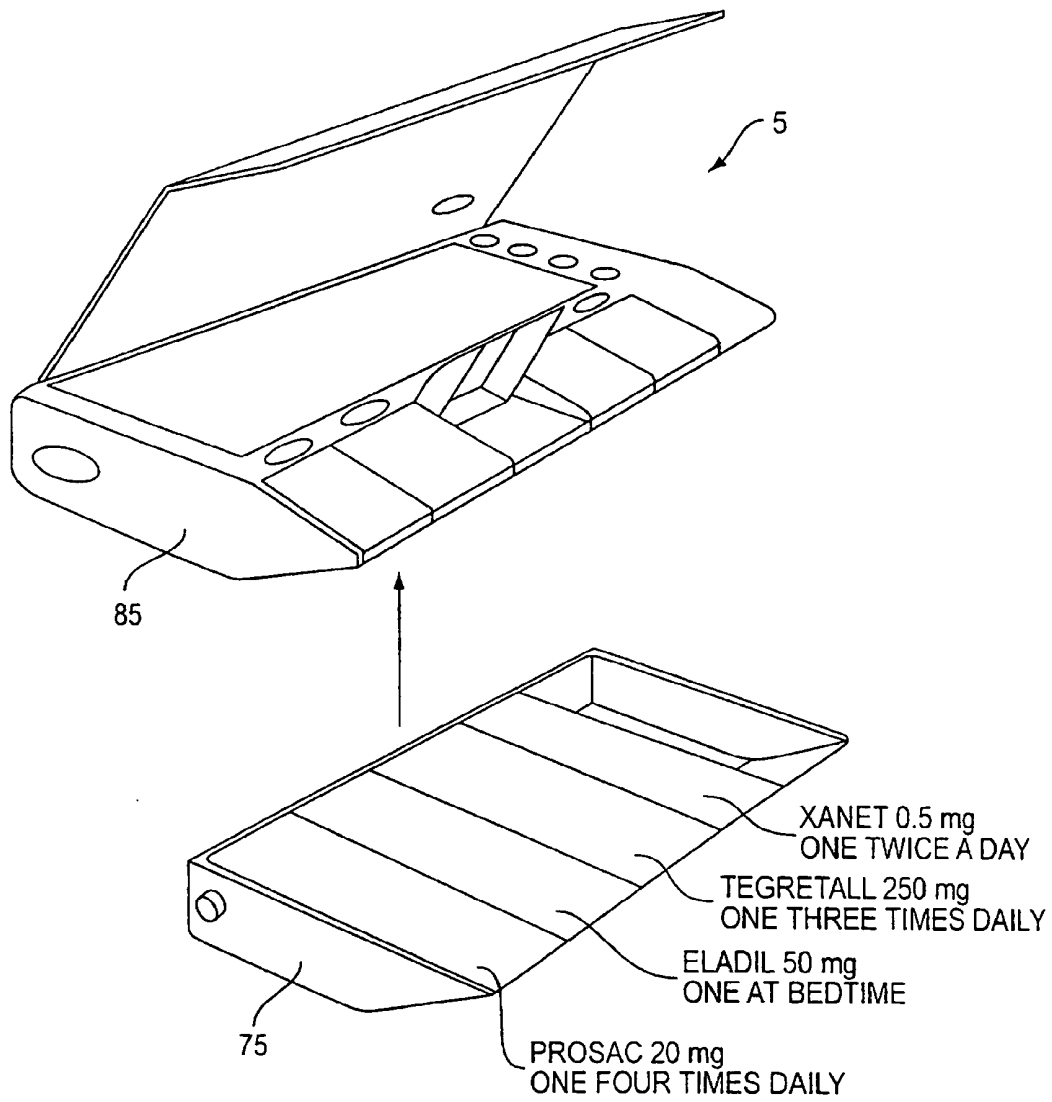

FIG. 21(a)

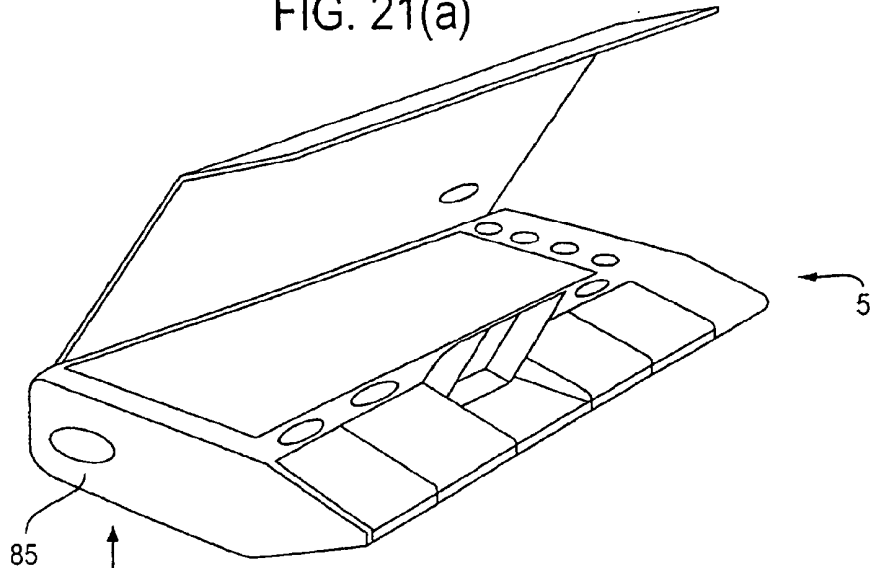

FIG. 21(b)

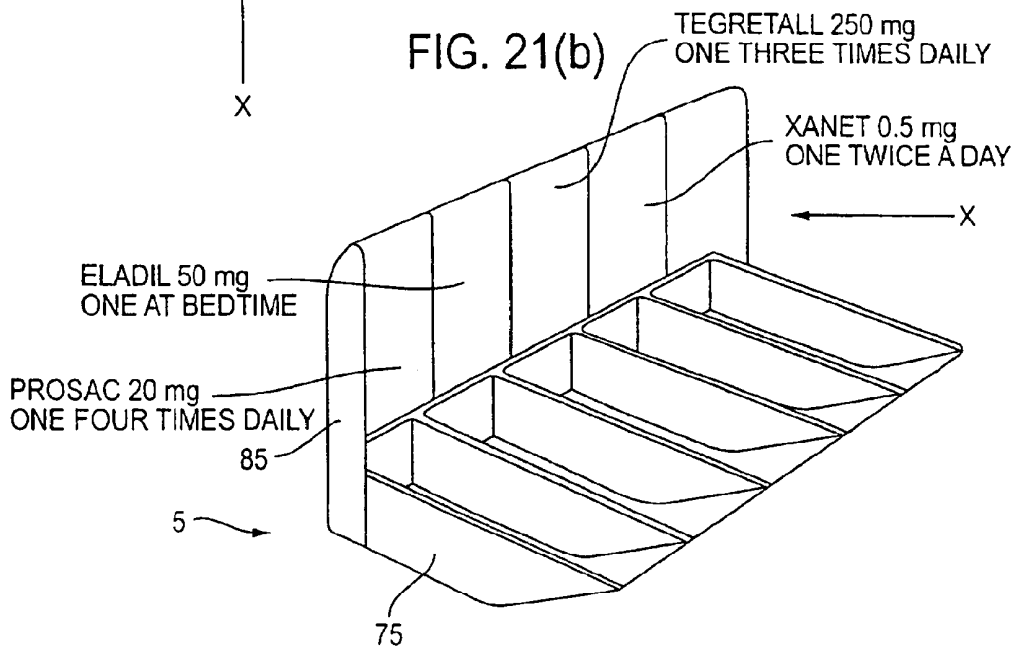

FIG. 22

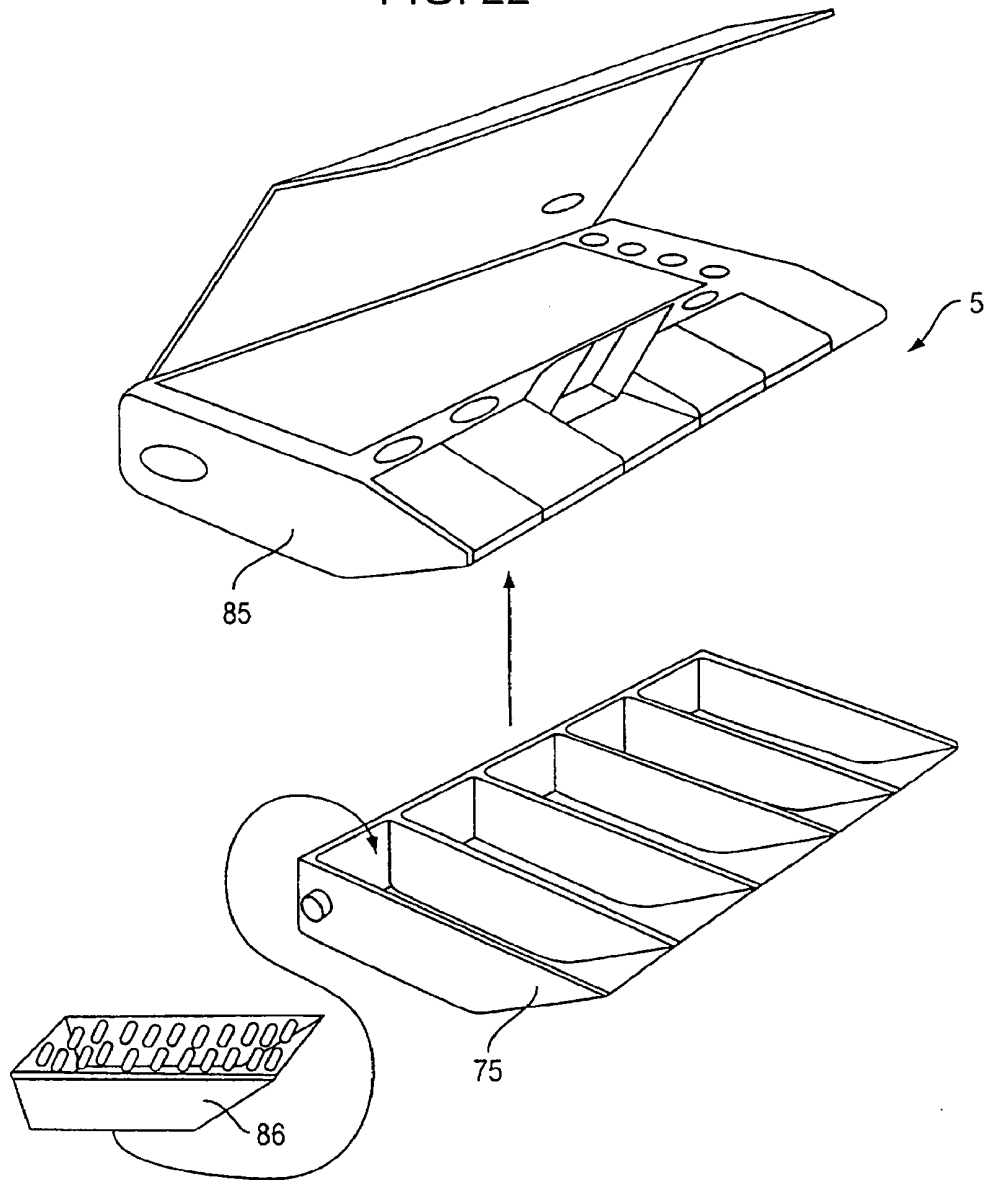
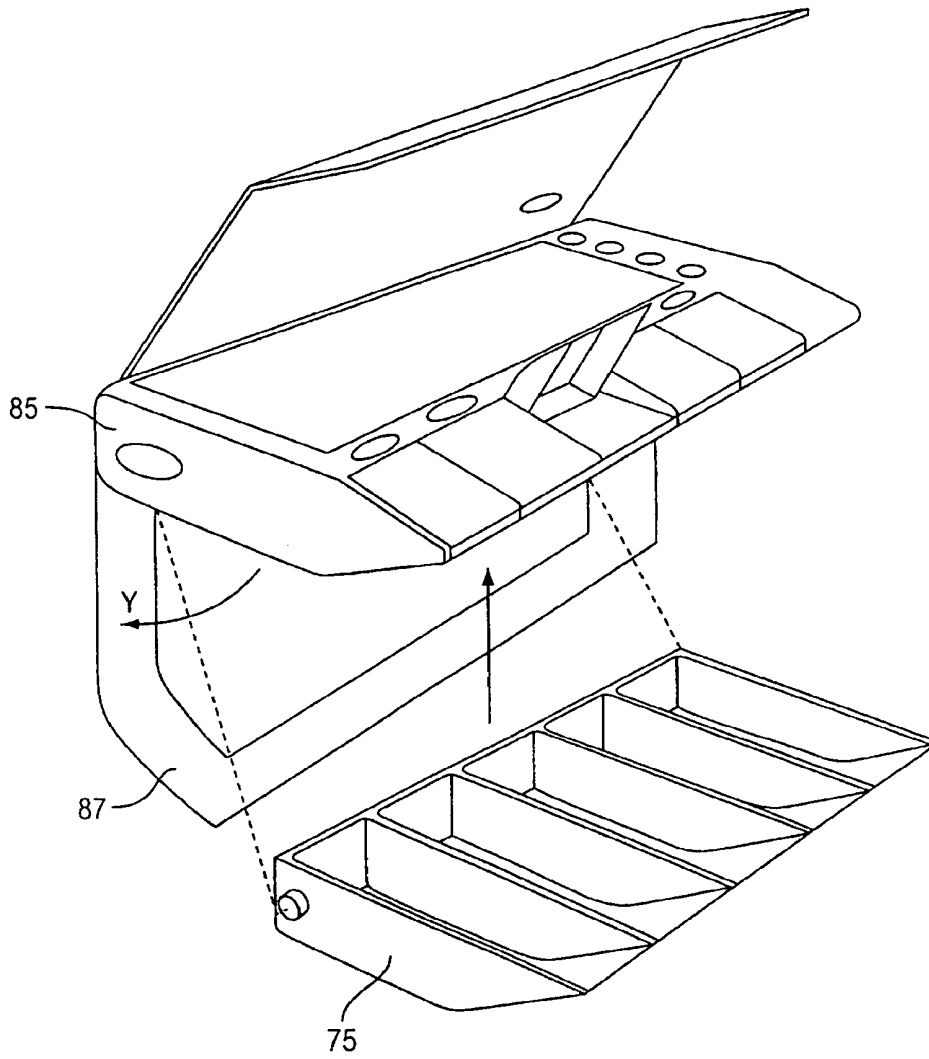

FIG. 23



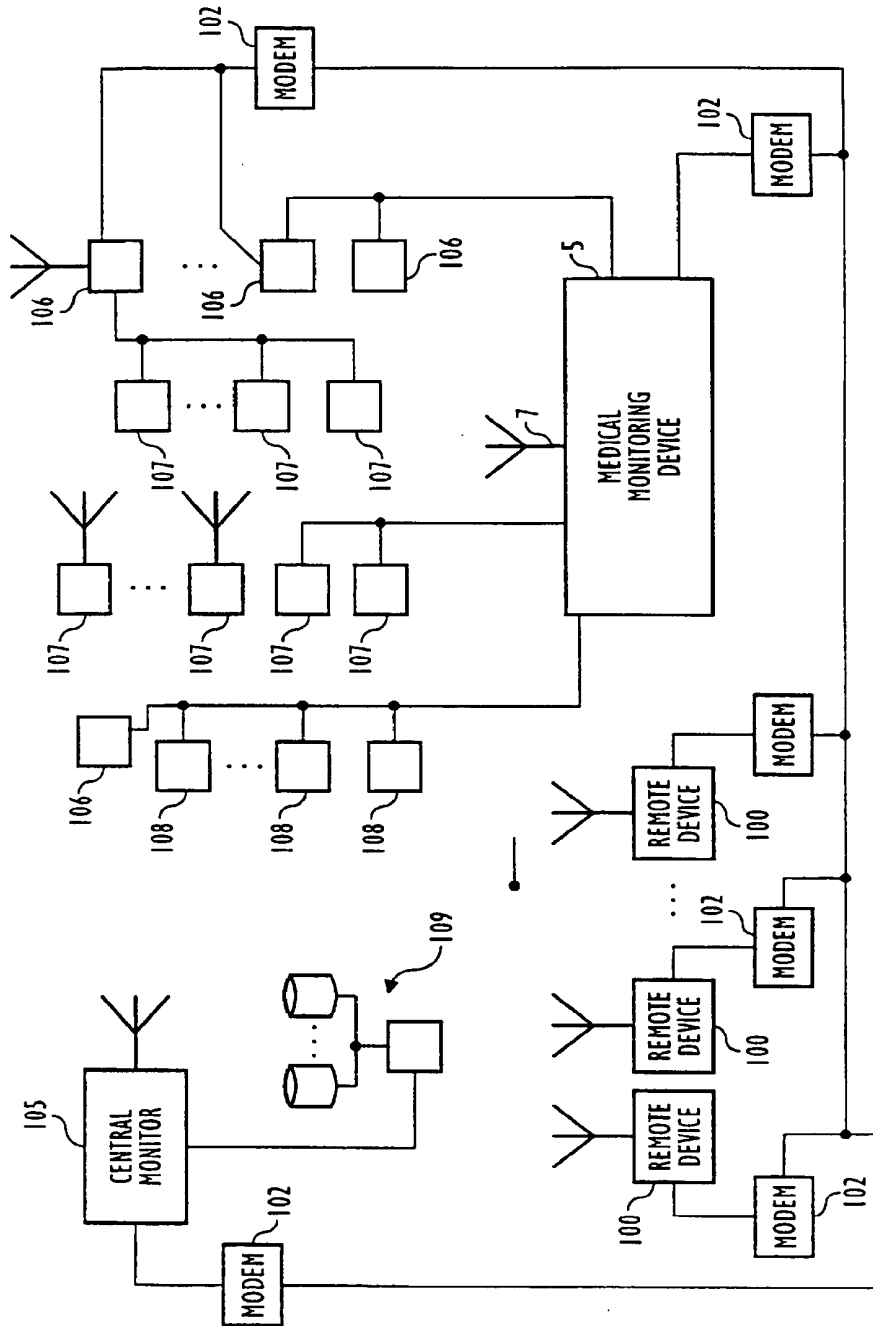

FIG. 24

**METHOD, APPARATUS, AND OPERATING
SYSTEM FOR REAL-TIME MONITORING
AND MANAGEMENT OF PATIENTS'
HEALTH STATUS AND MEDICAL
TREATMENT REGIMENS**

[0001] Priority for the present application is based on the following: (1) U.S. Provisional Application Ser. No. 60/040,128, filed Mar. 7, 1997; (2) U.S. Provisional Application Ser. No. 60/044,472, filed Apr. 18, 1997; (3) U.S. patent application Ser. No. 08/924,917, filed Sep. 8, 1997; (4) U.S. patent application Ser. No. 08/955,952, filed Oct. 22, 1997; (5) U.S. Provisional Application Ser. No. 60/068,473, filed Dec. 22, 1997; and (6) U.S. Provisional Application Ser. No. 60/051,389, filed Jul. 1, 1997.

FIELD OF THE INVENTION

[0002] The present invention relates to the field of medical devices for assisting with the administration of prescribed medical treatment regimens, and monitoring medical treatment progress.

BACKGROUND OF THE INVENTION

[0003] The prior art discloses a number of electronic devices that assist with the administration of prescribed medication and monitor the medical treatment progress. Medication monitoring devices such as those disclosed in U.S. Pat. Nos. 5,200,891 and 5,642,731 provide a number of functions for facilitating patient adherence to prescribed therapies, and for facilitating cross-correlation of compliance data and clinical information about the patient.

[0004] Such devices have a plurality of medication compartments, a microprocessor with associated circuitry for providing timing signals, signals and display messages and for reading inputs from buttons that convey programming and operating information. They rely on programmed schedules for providing audible and/or visual alert signals at the scheduled times for taking certain medications and indicate the specific compartment from which the particular medication is to be taken, and quantity to be taken. The device of U.S. Pat. No. 5,642,731 is also capable of collecting contemporaneous data concerning the patient's adherence to the medication schedule, the progression of the medical condition(s) being treated, symptoms and side effects the patient is experiencing and other information pertinent to monitoring and treating the patient's medical condition(s).

[0005] However, the prior art suffers from a number of inherent disadvantages that have been solved by the present invention. The prior art devices contain complex operating systems rendering them difficult to understand how to operate and extract medical and educational information, and lack the functionality for easily presenting patient queries and obtaining patient responses, and easily communicating with remote devices. The operating systems of the prior art devices are also inadequate in their ability to provide for differentiation of operating sequences pertinent to specific medications and treatment progress, further complicating their operation and monitoring of treatment regimens.

[0006] Further, the prior art devices lack the ability to gather contemporaneous data reflecting treatment progress, medical treatment regimen compliance, and patient health status through either a simple patient query interface, or monitors physically attached to the patient that monitor physiologic, cellular, molecular, endocrine and/or metabolic

events. The prior art devices also lack the ability to automatically adjust a treatment regimen based on an algorithm within the device that analyzes the contemporaneous data collected, and automatically adjusts a treatment regimen accordingly. The prior art devices also lack the ability to provide positive and negative feedback, and warnings to the patient, based upon the contemporaneous data collected. The prior art devices also suffer from a difficulty in giving repetitive reinforcing information on a per-medication basis, to encourage better compliance with the entire medical treatment regimen.

[0007] Further, the prior art devices fail to provide for automatic communication and transfer of data and information between the device and remote devices. In this regard, the prior art devices also lack the ability to provide for immediate transmission of the contemporaneous data reflecting the patient's treatment progress. Immediate transmission would enable a healthcare provider to perform a real-time evaluation of the contemporaneous data and adjust the patient's treatment regimen accordingly (the adjustment may range from simply revising medication schedules to requesting that the patient schedule an appointment with a physician, or even requiring that the patient proceed to a hospital emergency room).

[0008] The prior art devices further lack functionality for intensive, real-time monitoring of outpatients, which would provide the ability to monitor outpatients at an intensity relatively equal to that of monitoring patient's in a hospital.

[0009] With regard to the identification of the medications stored in the device, the prior art lacks the ability to provide for easy identification of the medication contained in each compartment. Additionally, the prior art devices include fixed volume medication storage capacities that limit the device's flexibility and portability, and are unable to easily provide the patient with reminders as to when to reload specific medication(s), which medication compartments to reload, how many to reload, and what the medication looks like.

[0010] In view of the foregoing disadvantages in the prior art, it is an object of the present invention to provide a medical monitoring device, operating system and communication system that largely automates the administration of medical treatment regimens, and that is simple to use. It is also an object of the present invention to provide various methods and algorithms that automate the administration of medical treatment regimens. Accordingly, the present invention provides advantages over the prior art devices by facilitating easy access to medication-specific, disease-specific and treatment-specific information. The present invention provides further advantages by including functionality for easily presenting patient queries and obtaining contemporaneous, meaningful patient responses providing various types of treatment information, including compliance information, information regarding side effects and health status, and information concerning the patient's general quality of life.

[0011] The operating system of the present invention provides further advantages over the prior art devices by clearly differentiating between operating sequences associated with each specific medication, further simplifying the device's operation and management of treatment regimens. Also, the present invention easily provides the patient with reminders as to when to reload specific medication(s), which medication compartments to reload, how much medication to reload, and what the medication looks like, even further simplifying the device's operation and management of treatment regimens.

[0012] It is a further object of the present invention to provide a medical monitoring device, operating system and method for managing the administration of medical treatment regimens capable of performing real-time gathering, storing and/or communicating of contemporaneous treatment data, facilitating real-time analysis of treatment progress. Accordingly, the present invention provides advantages over the prior art devices by enabling the medical monitoring device to gather contemporaneous patient data (data reflecting treatment progress, medical treatment regimen compliance, and patient health status) through either a simple patient query interface, or monitors physically attached to the patient (monitors that monitor physiologic, cellular, molecular, endocrine and/or metabolic events).

[0013] It is a further object of the present invention to provide a function whereby the medical monitoring device automatically adjust a treatment regimen based on an algorithm within the device that analyzes the contemporaneous data, and automatically adjusts a treatment regimen accordingly.

[0014] It is a further object of the present invention to provide for automatic communication and transfer of data and information between the device and remote devices. In this regard, the present invention provides advantages over the prior art by enabling immediate transmission of the contemporaneous data, which allows a healthcare provider to perform a real-time evaluation of the contemporaneous data and adjust the patient's treatment regimen accordingly (the adjustment may range from simply revising medication schedules to requesting that the patient schedule an appointment with a physician, or even requiring that the patient proceed to a hospital emergency room).

[0015] It is a further object of the present invention to provide functionality for intensive, real-time monitoring of outpatients. Accordingly, the present invention provides advantages over the prior art devices by enabling the ability to monitor outpatients at an intensity relatively equal to that of monitoring patient's in a hospital.

[0016] It is a further object of the present invention to provide the patient with positive and negative feedback and warnings, based upon the contemporaneous data, and to provide repetitive, reinforcing information on a per-medication basis, to encourage better compliance with the entire medical treatment regimen.

[0017] It is a further object of the present invention to provide a feature that, based upon the contemporaneous data, presents the patient or caregiver with positive and negative feedback concerning the patient's treatment regimen and progress, and provides repetitive reinforcing information on a per-medication basis. Accordingly, the present invention provides advantages over the prior art devices by encouraging better compliance with the entire medical treatment regimen managed by the device.

[0018] It is a further object of the present invention to provide a medical monitoring device, operating system and method for managing the administration of prescribed medical treatment regimens that provide identifying characteristics of the medication contained in each device compartment facilitating easy identification of the proper medications.

[0019] It is a further object of the present invention to provide for variability in the volume capacities of the medication compartments, expanding the device's flexibility and portability over the device's of the prior art.

[0020] Additional objects and attendant advantages of the present invention will be set forth, in part, in the description that follows, or may be learned from practicing or using the present invention. The objects and advantages may be realized and attained by means of the instrumentalities and combinations particularly pointed out in the appended claims. It is to be understood that the following general and detailed descriptions are exemplary and explanatory only and are not to be viewed as being restrictive of the invention, as claimed.

SUMMARY OF THE INVENTION

[0021] The present invention provides an electronic medical monitoring device, operating system, and method for managing and monitoring the administration of medical treatment regimens. The present invention provides for real-time access to important treatment information, real-time adjustment of treatment regimens and monitoring devices and sequences, and real-time patient/healthcare provider interaction, facilitating efficient and improved monitoring and management of medical treatment regimens. The present invention also provides for the collection of information concerning the treatment of the patient's medical condition(s) to assist the health care professional in monitoring the progression of the patient's medical condition(s) and treatment results. The invention collects contemporaneous information concerning the patient's compliance with the treatment regimen, the progression of the patient's medical condition(s), symptoms and side effects experienced by the patient, physiologic information (i.e., blood pressure or glucose levels), endocrine or cellular functioning (i.e., presence and quantity of circulating or serum polypeptide or steroid hormone levels, hepatic enzymes or other cellular metabolites detectable by a specific assay device containing receptors or antibodies, etc.), and the patient's general health status and quality of life. This information facilitates prompt, accurate, real-time analysis of the patient's progress, resulting in more efficient management of the patient's medical condition(s), health, and improved treatment results. The present invention provides a medical monitoring device that interfaces with a communications cradle or base unit for transferring data to and from remote devices. The present invention also provides for a medical monitoring device that is capable of direct communication to and from remote devices via wireless communication methods commonly known to those of ordinary skill in the art of electronic communication. The information is either immediately communicated to a remote device, or stored in the medical monitoring device for subsequent communication.

[0022] In one embodiment, the present invention provides a dedicated key, button, or touch point on a screen associated with each medication being administered or disease being treated. Each of the dedicated keys facilitates accessing information related to the associated medication or disease (i.e. electronic prescription labeling, pictures and color of the medication, description of the medication's function, conditions or diseases that the medication treats, side effects associated with the medication, drugs with which the medication interacts, etc.). An additional set of soft keys, buttons or touch points facilitates additional functionality (i.e. flexible applications, programming, switching between modes of operation, response to patient queries, patient entry of physiologic values, accessing additional information regarding unscheduled and missed doses, communicating with remote devices, scrolling through additional messages, etc.).

[0023] In a further embodiment, the present invention tracks timing and provides scheduled medication alarms indicating specific prescribed medication doses to be taken at particular times. The alarms comprise an audible signal and visual prompts or messages displayed on a display. The invention further provides medication compartments for storing the prescribed medications, and during a scheduled medication alarm, the invention provides signals indicating the particular compartments from which the medications are to be taken, and/or amounts of liquid, injectable, or aerosolized medications to be taken.

[0024] In a further embodiment, the present invention provides a selectable sound and/or light alarm means that presents audible and/or visible signals indicating messages or instructions to the patient. The audible signals may comprise music, a melody, a series of tones, or other sounds conveying a message, and the visible signals may comprise lights, also conveying a message. The healthcare provider selects audible and/or visible signals during the programming of the device, and the user can change the signal settings during execution of the device's programming mode. The medical monitoring device of the present invention thereby provides a means whereby a patient suffering from an incapacitating condition (i.e., senility, Alzheimer's, organic brain disease, etc.) can operate the medical monitoring device and understand messages and/or instructions conveyed during device operation.

[0025] In a further embodiment, the present invention provides a method whereby a medical monitoring device provides access to refrigerated or frozen medications. The device provides scheduled medication alarms, as specified above, and dispenses tokens or keys that unlock or provide access to a refrigerator or freezer device storing prescribed medication (s) to be taken. Alternatively, the device electronically provides access to the refrigerated or frozen prescribed medications when a particular medication compartment is opened.

[0026] In a further embodiment, the present invention further provides for a variable capacity compartment tray and storage system that affords complete flexibility in the quantities and volumes of solid, liquid or aerosolized doses contained within the unit. The variable capacity compartment tray also provides for pre-loading, and pre-labeling of medications. Accordingly, when the patient exhausts a supply of medication in one tray, a second pre-loaded and pre-labeled tray can quickly and easily replace the exhausted tray.

[0027] In a further embodiment, the present invention provides a graphic display, allowing for the display of graphic images or text in any language, and allowing for a symbolic or pictorial set of instructions for illiterate patients. The graphic display can display graphic images that indicate the patient's progress. For example, if the patient is adhering to the treatment regimen, the graphic image may comprise a representation of the patient's body showing improved health and wellness, or a smiling face, or other symbols of improving health, wellness or achievement. Likewise, if the patient is not adhering to the treatment regimen, the graphic image may comprise a representation of declining health and wellness, or a frowning face, or other symbols of declining health, wellness or achievement. An algorithm in the device itself automatically and periodically updates or changes the graphic images, based upon the record of the patient's behavioral adherence to the treatment regimen collected and stored in the device.

[0028] In a further embodiment, the present invention also tracks the patient's consumption of each medication, and

provides the patient with "Refill" reminders. The "Refill" reminders tell the patient when to reload medication, which medication to reload, the quantity to reload; when to call the health care provider or pharmacy for refills, etc. The device either automatically presents the "Refill" messages, or presents the "Refill" messages when the patient presses a dedicated key for a particular medication. Additionally, a software algorithm automatically adjusts "Refill" reminders, future dosing regimens, and instructions, based upon the patient taking previous doses too early, too late, or not at all; and additionally based upon the pharmacokinetic properties aspects of a particular drug contained within a particular compartment.

[0029] In a further embodiment, the present invention provides a method and means for wireless communication with and polling of the medical monitoring device. The wireless communication may be by a cellular telephone link, satellite link, or other radio communication means, commonly known to those of ordinary skill in the art of electronic communications. The wireless communication feature allows the transmission of patient query data to the medical monitoring device, for conducting a health status assessment, and monitoring adverse effects or side effects experienced by the patient, treatment progress, and the patient's general quality of life. The wireless communication feature also facilitates polling of the medical monitoring device or other monitoring devices to retrieve patient response data, physiologic data, hormones, enzymes or other metabolite concentrations, and any other physical, chemical, molecular, endocrine, or metabolic data related to the patient for real-time analysis of the patient's health status and treatment progress.

[0030] The wireless communication feature provides improvements over the prior art in that a medical monitoring device with such a feature does not necessarily require a long-term memory storage function (i.e., week or month). The wireless communication feature also facilitates periodic, spontaneous, and or random, data transmission or polling of data, related to the patient's treatment regimen and health status. In addition, the device is capable of transmitting data concerning the patient's condition promptly after a particular data element, sequence of data elements, or combination of data elements is entered by the user. The wireless transmission feature thereby enables an increase in the frequency and intensity of monitoring, up to the capacity for real-time monitoring of outpatients. Further, the wireless communication feature provides for prompt data transfer where the patient's condition warrants prompt attention. The wireless communication feature thereby allows for outpatient treatment of seriously ill patients, to keep them out of hospitals and nursing homes, with more independence, and less health care expense.

BRIEF DESCRIPTION OF THE DRAWINGS

[0031] FIG. 1 illustrates a block diagram of the electronic circuitry of the medical monitoring device of the present invention.

[0032] FIGS. 2(a) and 2(b) illustrate a top/side view and a bottom/rear/side view of the medical monitoring device of the present invention, including the dedicated and soft function keys, display, and infrared communications port.

[0033] FIG. 3 illustrates the cradle of the present invention, and the interface between the cradle and medical monitoring device.

[0034] FIG. 4 illustrates a flow chart of the general operation of the medical monitoring device, operating system and method of the present invention.

[0035] FIG. 5 illustrates the liquid crystal display, dedicated keys and soft function keys in the passive mode of the medical monitoring device, operating system and method of the present invention.

[0036] FIGS. 6(a)-(c) illustrate the liquid crystal display, dedicated keys and soft function keys during a dedicated key operating sequence of the medical monitoring device, operating system and method of the present invention.

[0037] FIGS. 7(a)-(e) illustrate the liquid crystal display, dedicated keys and soft function keys during an operating sequence of a scheduled medication alarm operating sequence of the medical monitoring device, operating system and method of the present invention.

[0038] FIGS. 8(a)-(b) illustrate the liquid crystal display, dedicated keys and soft function keys during an unscheduled medication alarm operating sequence of the medical monitoring device, operating system and method of the present invention.

[0039] FIGS. 9(a)-(b) illustrate the liquid crystal display, dedicated keys and soft function keys during different general signals of the medical monitoring device, operating system and method of the present invention.

[0040] FIGS. 10(a)-(b) illustrate the liquid crystal display, dedicated keys and soft function keys during a mode-select function of the medical monitoring device, operating system and method of the present invention.

[0041] FIGS. 11(a)-(c) illustrate the liquid crystal display, dedicated keys and soft function keys during a "Medication Compliance" mode operating sequence of the medical monitoring device, operating system and method of the present invention.

[0042] FIGS. 12(a)-(d) illustrate the liquid crystal display, dedicated keys and soft function keys during a "Patient Query" mode operating sequence of the medical monitoring device, operating system and method of the present invention.

[0043] FIGS. 13(a)-(h) illustrate the liquid crystal display, dedicated keys and soft function keys during a "Medication Schedule—Program" mode operating sequence of the medical monitoring device, operating system and method of the present invention.

[0044] FIGS. 14(a)-(c) illustrate the liquid crystal display, dedicated keys and soft function keys during a "Refill" alarm operating sequence of the medical monitoring device, operating system and method of the present invention.

[0045] FIGS. 15(a)-(b) illustrate the liquid crystal display, dedicated keys and soft function keys during a "Refill" mode operating sequence of the medical monitoring device, operating system and method of the present invention.

[0046] FIG. 16 illustrates a removable tray of one embodiment for use with the medical monitoring device, operating system and method of the present invention.

[0047] FIG. 17 illustrates a removable tray of a further embodiment for use with the medical monitoring device, operating system and method of the present invention.

[0048] FIG. 18 illustrates a removable tray of a further embodiment for use with the medical monitoring device, operating system and method of the present invention.

[0049] FIG. 19 illustrates a removable tray storing a pill bottle for use with the medical monitoring device, operating system and method of the present invention.

[0050] FIG. 20 illustrates a removable tray with sealed, labeled medication compartments for use with the medical monitoring device, operating system and method of the present invention.

[0051] FIGS. 21(a) and 21(b) illustrate two views of the medical monitoring device and removable tray with labels on the underside of the device.

[0052] FIG. 22 illustrates a removable tray and compartment insert for use with the medical monitoring device, operating system and method of the present invention.

[0053] FIG. 23 illustrates the removable tray and frame or support cover for use with the medical monitoring device, operating system and method of the present invention.

[0054] FIG. 24 illustrates a block diagram of a medical monitoring system of monitors, sensors, delivery devices, and remote devices pursuant to the present invention.

DETAILED DESCRIPTION OF EXEMPLARY EMBODIMENTS

[0055] All patents, patent applications and literatures cited in this description are incorporated herein by reference in their entirety. In the case of inconsistencies, it is intended that the present disclosure, including definitions, prevail.

[0056] The present invention provides an electronic device, operating system and method that assists a patient user with the administration of medical treatment regimens, and assists health care providers with providing the most efficient and effective treatment for medical conditions. Similar devices are disclosed in U.S. Pat. Nos. 5,200,891 and 5,642,731 incorporated herein by reference in their entireties.

[0057] In one exemplary embodiment, as illustrated in FIG. 1, the medical monitoring device of the present invention utilizes a 4-bit microcontroller chip 10 interfaced with a 320×100 pixel liquid crystal display 11 ("LCD") with graphics capabilities. The device operating system is stored in a 128×8 bit external EPROM 12 and the variable data (i.e. medication scheduling data, treatment information, patient query data, and response data) is stored in an external 128×8 bit SRAM 13. The crystal oscillator circuit 14 provides a clock signal to the microcontroller 10, the clock circuit 15 tracks the date and time of day. Five compartment switches 16-20, five dedicated keys 21-25 and four soft function keys 26-29 are connected to inputs of the microcontroller 10 for supplying status signals, function commands and patient query responses to the microcontroller 10 for processing.

[0058] The device enables interaction with health care providers through a communication port 17. Communication port 17 comprises an infrared input/output port capable of communicating directly with a personal computer 18. Alternatively, the communication port may comprise a serial port capable of communicating with a modem or directly with a PC.

[0059] The health care provider can download information to the device, such as programming data concerning the prescribed medication schedules, programming data concerning the selection and control of audible and/or visible signals (i.e., sounds, music, melodies, tones, colored lights, etc. for communication with impaired patients), information concerning the prescribed medication and medical condition(s) being treated, and patient queries associated with the medical condition being treated. The health care provider can also upload information from the device, such as data concerning the

patient's adherence to the prescribed medication schedules and information representing the patient's responses to patient queries.

[0060] The device itself, as illustrated in FIGS. 2(a) and 2(b), has a top face 51. The top face 51 includes openings for the LCD 11, dedicated keys 21-25, soft function keys 26-29 and medication compartments 31-35. The medication compartments 31-35 have respective compartment doors 36-40 covering them. The device also has a hinged top cover 52 for opening and closing the device. The medication compartments 31-35 are housed in a tray that inserts into the bottom of the device. The tray may be of various sizes, and may even be large enough to maintain a pill bottle, a medication inhaler, syringe, or other large medication container. Further, the medication compartments may directly accommodate liquid, injectable, or aerosolized medications.

[0061] Compartment switches 16-20 signal the microcontroller 10, indicating when compartment doors are opened and closed. Each of the medication compartments 31-35 and its respective compartment door is associated with a compartment switch that senses the opening and closing of the compartment door. When a particular compartment door is opened, the associated compartment switch signals the microcontroller 10, and the microcontroller processes the signal according to the specific status of the device at that time. For example, as described in detail below, if a compartment door is opened during a scheduled medication alarm, the microcontroller 10 interprets this as an indication that the patient has complied with the prescribed schedule for the particular medication contained in that compartment. The compartment switches thereby facilitate the device's tracking of the patient's adherence to prescribed medication schedules.

[0062] The device provides a means for interacting with the patient through a series of operations controlled by the dedicated keys 21-25 and soft function keys 26-29. The dedicated keys 21-25 enable the patient to retrieve information concerning specific medications contained in the device's medication compartments or concerning specific diseases. The soft function keys 26-29 enable the patient to respond to patient queries concerning medication side effects, adherence to medication schedules, treatment progress, health status assessment and patient's quality of life. The soft function keys 26-29 further facilitate other operations, such as a programming mode for modifying device settings and adjusting medication schedules and treatment data, and other types of information capture. Alternatively, the present invention may employ points on a touch screen that function in the same manner as the dedicated keys 21-25 and soft function keys 26-29.

[0063] Each of the dedicated keys is associated with the particular medication compartment located adjacent to it. Specifically, dedicated key 21 is associated with medication compartment 31, dedicated key 22 is associated with medication compartment 32, dedicated key 23 is associated with medication compartment 33, dedicated key 24 is associated with medication compartment 34, and dedicated key 25 is associated with medication compartment 35. Each dedicated key controls the display or entry of information related to the specific medication stored in its associated medication compartment or related to the medical condition for which that medication is prescribed.

[0064] Referring to FIGS. 4 and 5, once programmed, the device remains in a passive mode 61 from which one of a

plurality of events can occur. In the passive mode 61, the device displays the current time of day, the patient's name and the patient's upcoming medication schedule. Alternatively, the device may also display the date. The display of the patient's drug schedule comprises a display, located directly above each dedicated key, of the next prescribed time that the patient should take the medication contained in the medication compartment associated with that key. For example, as illustrated in FIG. 5, the time of day is 3:15 p.m., and the patient's drug schedule entails taking the medication contained in compartments 21 and 22 at 5:00 p.m., compartments 23 and 24 at 8:00 p.m. and compartment 25 at 9:00 am the following morning.

[0065] From the passive mode 61, the patient can readily obtain information concerning any of the medications contained in the medication compartments by actuating or pressing the dedicated key associated with the medication regarding which the information is sought. When the patient actuates or presses a dedicated key one time, the device displays a prescription label message concerning the medication contained in the medication compartment associated with the actuated key. For example, as illustrated in FIG. 6(a), if the patient actuates dedicated key 23, the device displays the name of the medication contained in the associated medication compartment 33 ("Coumadin 50 mg"), the prescribed schedule for that particular medication ("take 2 pills at 08:00 pm"), a graphic representation and indication of the color of the medication 60, information concerning the optimum conditions for taking the medication ("to be taken with water"), and an arrow 62 pointing to the dedicated key actuated and associated medication compartment. If the patient does not actuate any other keys for a predetermined wait period (preferably approximately from 5-30 seconds), then the device returns to passive mode 61.

[0066] If the patient then actuates a different dedicated key, either within the predetermined wait period or after that period of time, the device displays the label message concerning the medication contained in the medication compartment associated with that key. For example, as illustrated in FIG. 6(b), if the patient actuates dedicated key 22, the device displays the name of the medication contained in the associated medication compartment 32 ("Demerol 100 mg"), the prescribed schedule for that particular medication ("take 3 pills at 05:00 pm"), a graphic representation and indication of the color of the medication 61, information concerning the optimum conditions for taking the medication ("to be taken after meals"), and an arrow 62 pointing to the actuated dedicated key and associated medication compartment. Then, as specified above, if the patient does not actuate any other keys for a predetermined wait period, the device returns to passive mode.

[0067] If the patient actuates the same dedicated key 22, within the predetermined wait period relative to the first actuation, then the device displays additional information concerning the medication contained in the associated medication compartment. For example, as illustrated in FIG. 6(c), if the patient actuates dedicated key 22 within the predetermined wait period relative to the first actuation, the device displays descriptive information concerning the medication contained in the associated medication compartment (Demerol). Also, the controller assigns page up and page down functions to the soft function keys 28 and 29, respectively. Actuation of the page up and page down soft function keys 28 and 29 causes the microcontroller 10 to scroll through screen

displays containing additional information concerning the associated medication. Then, as specified above, if the patient does not actuate any other keys for the predetermined wait period, the device returns to passive mode.

[0068] Further successive actuations of a same dedicated key will access additional information concerning the medication contained in the medication compartment associated with the actuated key. The additional information may include information about the particular medical condition that the medication treats (i.e. general information about the medical condition, information about how the medication impacts the condition, and information about the patient's prognosis based on adherence to the prescribed medication schedule). Further information may concern potential side effects and adverse reactions associated with the particular medication, the Process of diagnosing or treating the medical condition, harmful or adverse interaction with other medications, and laboratory procedures or other diagnostic tests involved in diagnosing and treating the medical condition.

[0069] Also from the passive mode 61, an alarm may activate signaling the patient through visual and/or audible alert signals. The alarm may either be a scheduled medication alarm, or a general alarm. The scheduled medication alarm alerts the patient and indicates that certain scheduled medication doses are due to be taken. The general alarm alerts the patient and indicates that some other action is required. The other action may be one of several possibilities, including response to certain patient queries, performance of a particular test, placing the device within the cradle for communication with a remote device, phoning or making an appointment with the health care provider, giving an injection, inhaling an aerosolized medication, etc.

[0070] Referring to FIG. 7(a), when a scheduled medication alarm occurs, the device continues to display the current time, and displays a message indicating that scheduled medication(s) are due to be taken. The device designates the particular scheduled medications with arrows 62 pointing to the appropriate medication compartments. The patient can access specific information concerning the medications that are the subject of a scheduled medication alarm by actuating the dedicated key associated with one of those medications. Further, during a scheduled medication alarm, the microcontroller 10 assigns a snooze function to the soft function key 26, and actuation of the snooze key suspends the alarm for a predetermined period of time, previously programmed into the device (i.e. 1 hour), as illustrated in FIG. 7(e). The snooze function defaults to 15 minutes if not overridden during device programming. As illustrated in FIG. 7(b), upon actuating dedicated key 22, the device displays the name and strength of the medication in the upper left corner of the LCD 11 in reverse video, the prescription requirements for the associated medication, a request that the patient take the prescribed quantity at that time and any special instructions ("Take 3 now with water").

[0071] When the patient opens the appropriate medication compartments during a scheduled medication alarm, the compartment switch associated with each compartment signals the microcontroller 10. The microcontroller 10 then displays a message on the LCD 11, designating the prescribed quantity for the medication in the opened compartment and the conditions for taking the medication, as illustrated in FIG. 7(c). The message requests that the patient either take the designated quantity prescribed for the medication or alterna-

tively actuate the soft function key 29 to indicate that the medication cannot be taken, as illustrated in FIG. 7(c).

[0072] Then, actuating the "I Can't" soft function key 29, signals the microcontroller 10, which displays an appropriate message. For example, as illustrated in FIG. 7(d), the message queries the patient as to why the scheduled medication cannot be taken, with the potential responses of "Need a refill" and "Side Effects" assigned to soft function keys 28 and 29, respectively. Actuating the soft function key assigned to a particular response signals the microcontroller 10 and indicates the patient's response, and the microcontroller 10 records the response along with other associated information (i.e. the particular medication to which the response relates and the time of day when the response was given). Actuating the soft function key 29 indicating that the patient is experiencing adverse reactions or side effects may then prompt the microcontroller 10 to query the patient as to the particular reactions or effects experienced, as illustrated in FIGS. 12(a)-12(d). The microcontroller 10 will again record the patient's response along with other associated data.

[0073] Opening and closing a designated compartment, during a scheduled medication alarm, signals the microcontroller 10, indicating that the patient adhered to the prescribed schedule for the medication contained in the compartment. The microcontroller 10 then records the patient's adherence accordingly. If the patient fails to obey a scheduled medication alarm and does not open and close each of the designated medication compartments, within a predetermined period of time or until the next scheduled medication alarm, then the alarm will continue at periodic intervals (i.e. 15 minutes). The alarm will also provide a visual signal (i.e. "MISSED MEDICATION"), informing the patient that a scheduled medication was not taken, and designating the appropriate compartment and necessary quantity. The device may display other messages on the LCD 11, warning the patient of the adverse consequences associated with the failure to adhere to the particular medication schedule. The scheduled medication alarm will deactivate once the patient accesses all of the designated medication compartments associated with the particular alarm.

[0074] In a further embodiment, the present invention provides an operating system, method and apparatus that automatically adjusts the patient's treatment regimen (i.e., the patient's scheduled medication times and doses) based on patient compliance data, or other monitored aspects of the patient's treatment progress. With patients taking medication for chronic and/or acute illnesses, where a healthcare provider prescribes medication at fixed intervals or specific times, while it is preferable that patients take the medications at the prescribed intervals, patients may fail to adhere to the prescribed schedules. At other times, it is more convergent for patients to take a dose earlier than prescribed. For example, at a prescribed dosing time, the patient may be unable to take a dose because of a scheduling conflict, or for some other reason, the patient may need to take the medication earlier than prescribed.

[0075] In certain instances, is critical, however, for patients to take all of the prescribed doses for a given time period. Taking all of the doses of certain drugs in a given time period optimizes the efficacy of drug therapy in treating the underlying illness or illnesses. Further, There should not be too short or too long of an interval between doses. Too short an interval can cause unacceptable, even lethal side effects or adverse drug reactions, and too long an interval between

doses can cause unacceptable break-through symptoms, a worsening of the illness, re-hospitalization, or even death.

[0076] The present invention, therefore, provides for an algorithm or algorithms that automatically adjust subsequent dosing intervals when the medical monitoring device determines a need for such adjustments to safely, properly, and optimally administer the remaining doses. For example, the medical monitoring device of the present embodiment would include an algorithm for calculating the next scheduled dose time based on the timing of a current dose. If the patient opens a compartment outside of a specified window of time for a scheduled dose, or while the device is in the passive mode as described above, the device provides audible and visual signals indicating that the patient is accessing an unscheduled dose, referring to FIGS. 8(a) and 8(b). If the patient then actuates the "Continue" soft function key 29, and then the "Taking Pill" soft function key 27, the device would record information concerning the unscheduled dose.

[0077] Additionally, the device would execute an algorithm that analyzes the timing of the unscheduled dose with regard to the previous and next scheduled doses for that medication, and calculate a modified next scheduled dose accordingly. The medical monitoring of the present embodiment could further include algorithms that analyze monitored data, as described in detail above, and adjust subsequent dosing schedules based on actual patient progress and/or reactions to previous doses, or based on any other monitored aspects of the patient's physical health and symptoms. The device of the present embodiment will optimize the patient's dosing intervals; thereby, reducing side effects, adverse reactions, and illness symptom break-through; resulting in optimized medical treatment and quality of life.

[0078] In a further embodiment, the present invention provides a method whereby a medical monitoring device provides access to refrigerated or frozen medications. In at least one of the medication compartments, the device stores tokens or keys that provide access to a refrigerated container storing prescribed medication(s) to be taken. When a scheduled medication alarm occurs, the device indicates that a token or key should be removed from a particular compartment, and that token or key in turn provides access to the appropriate refrigerated container storing the medication to be taken. Alternatively, the device electronically provides access to the refrigerated container. In such a case, when a scheduled medication alarm occurs, the device indicates a particular compartment to open. Upon opening that compartment, the device transmits, through a wireless means, a signal that unlocks the appropriate refrigerated container providing access to a prescribed medication that is the subject of the alarm. The wireless means can comprise any electronic transmission method known to those skilled in the art, i.e., infrared or a radio frequency transmission.

[0079] In a further embodiment of the present invention, the audible scheduled medication alarm signal includes the use of a transducer or voice generation chip and speaker that emits speech for giving audible instructions concerning the prescribed medications. In this embodiment, a number of common messages and/or words generally associated with prescription instructions are stored in the SRAM 13 or EPROM 12 (i.e. "Take", "Pill", "A", "Pills", "Water", "Juice", "Times", "One", "Two", "Day", etc.). The messages and/or words are stored in a table look-up format. And the device plays audible messages by sequencing through specific combinations (i.e. "Take Two Pills With Milk Two Times A Day").

Also, additional messages specific to particular medications could be programmed into the SRAM 13 or EPROM 12 for alerting the patient under certain predefined circumstances.

[0080] When the patient opens a medication compartment while the device is in the passive mode and no scheduled medication alarm is occurring, an unscheduled pill alarm occurs. During an unscheduled pill alarm, the device provides audible and visual signals. Referring to FIG. 8(a), the visual signals comprise a displayed message, with the medication label and strength in reverse video at the upper left corner of the LCD 11, along with a message that the medication should not be taken at that time. The device also displays a message indicating that the patient should actuate the "Continue" soft function key 29 for more information. Actuating the "Continue" soft function key initiates the display of the medication label and strength in reverse video at the upper left corner of the LCD 11, along with the prescribed medication schedule for the medication contained in the opened compartment. The device also displays a query as to why the compartment was opened, with potential responses assigned to particular soft function keys.

[0081] Other alarms occurring from the passive mode alert the patient concerning other medical related activities. For example, as illustrated in FIG. 9(a), an alarm can alert the patient that a dose of an inhaler is due to be taken. As illustrated in FIG. 9(b), additional alarms can remind the patient to perform certain tests, such as a blood sugar test.

[0082] In a further embodiment, the present invention provides a selectable sound and/or light alarm means that presents audible and/or visible signals indicating messages or instructions to the patient. For example, during a medication alarm, the medical monitoring device provides audible and/or visible signals. The audible signals may comprise music, a melody or a series of tones whereby, if the patient opens a wrong compartment during a medication alarm, then the device would play a sad or disturbing piece of music, melody or series of tones. If the patient opens the proper compartment (s) during a medication alarm, then the device would play a happy or pleasing piece of music, melody or series of tones. Further, the visible signals may comprise lights, whereby, if the patient opens a wrong compartment during a medication alarm, then the device would illuminate or display a red light indicating "stop", or a yellow light indicating "caution." If the patient opens the proper compartment(s) during a medication alarm, then the device would illuminate or display a green light indicating "go." The audible and/or visible signals would be selected during the programming of the device by a healthcare provider, or by a user during execution of the programming mode of the medical monitoring device. The medical monitoring device of the present invention thereby provides a means whereby a patient suffering from an incapacitating condition (i.e., senility, Alzheimer's, organic brain disease, etc.) could operate the medical monitoring device and understand messages or instructions conveyed by the device. Further, many other possible means may be employed for communicating with an impaired patient, including vibration.

[0083] Further, while in the passive mode 61, soft function key 26 controls a mode-select function that initiates an active mode of operation whereby the patient initiates different operating modes of the device. Referring to FIG. 10(a), actuating the mode-select soft function key 26 from the passive mode displays a mode-select screen, wherein each soft function key is assigned a different mode-select function. Soft

function key **26** initiates a “Medication Compliance” mode, soft function key **27** initiates a “Pour” mode (for refilling medication compartments), soft function key **28** initiates a “Patient Query” mode, and soft function key **29** is assigned a “More” function. Actuation of the “More” soft function key **29** scrolls the display for accessing additional modes of operation, as illustrated in FIG. **10(b)**. The additional modes of FIG. **10(b)** are a “Medication Schedule—Program” mode, a “Device Settings—Program” mode, and a “Communication” mode.

[0084] Referring to FIG. **11(a)**, in the “Medication Compliance” mode, the device displays a summary screen with the title “Compliance Summary” displayed in reverse video in the upper left corner, and a synopsis of the patient’s medication schedule adherence. Specifically, above each medication compartment containing a medication for which the patient missed scheduled doses, the device displays the number of missed doses for the medication contained in the associated compartment. For example, as illustrated in FIG. **11(a)**, the patient missed **4** doses of the medication in compartment **32** (the compartment associated with dedicated key **22**), **1** dose of the medication in compartment **34** (the compartment associated with dedicated key **24**) and **2** doses of the medication in compartment **35** (the compartment associated with dedicated key **25**).

[0085] The patient then actuates a particular dedicated key to obtain the details concerning the missed schedules for the medication contained in the associated compartment. For example, as illustrated in FIG. **11(b)**, when dedicated key **22** is actuated, the device displays the name and strength of the associated medication in reverse video in the upper left corner of LCD **11**, and displays messages indicating that the patient missed certain doses at specified dates and times. In this instance, since only three missed doses fit on the LCD screen, soft function keys **28** and **29** serve as scroll keys for scrolling up and down to review additional entries of missed medication doses. Further actuation of the dedicated key provides the patient information concerning the potential or likely consequences of missing the medication dose, as illustrated in FIG. **11(c)**. Additionally, soft function key **28** serves a “NEXT” function for accessing additional information concerning the missed doses of the particular medication, and for accessing information concerning unscheduled medication doses taken by the patient. The device thereby provides educational information for motivating the patient to comply with the medication schedules.

[0086] Referring to FIGS. **12(a)-12(d)**, in the “Patient Query” mode, the device displays a series of questions concerning health status assessment, adverse effects or side effects experienced by the patient, treatment progress and the patient’s general quality of life. Other questions that require responses from the health care provider may be posed. The questions are framed in either true/false (yes/no) format, scaling format or multiple choice format, and the soft function keys **26-29** are assigned particular responses according to the question format. Actuating a soft function key signals the microcontroller **10** and indicates the particular response chosen, and the microcontroller **10** records the patient’s or health care provider’s responses along with associated data (i.e. date and time of questioning). Questions may also be framed in decision tree format depending on the extent and complexity of the details necessary for the most efficient administration

of medication, or administration of other components of the medical treatment plan, for treating a particular medical condition.

[0087] The “Communication” mode facilitates the transfer of data between the medical monitoring device and a remote device. During the communication mode the health care provider can download specific programming data associated with a particular patient’s prescribed medication schedule and medical treatment regimens, and upload patient response data or other information, through the communications port **17**.

[0088] Further, referring to FIGS. **13(a)-13(f)**, in the “Medication Schedule—Program” mode, the device allows the patient or health care provider to modify prescribed medication schedules for a particular medication. Actuating the dedicated key **21**, while in the “Medication Schedule—Program” mode, facilitates the modification of the prescribed schedule for the medication contained in the associated medication compartment. The device displays an adjust message, with the name and strength of the medication being adjusted, in reverse video in the upper left corner of the LCD **11**, and displays the current prescribed frequency (“Take **2** pills **4** times per day”), as illustrated in FIG. **13(a)**. The number of pills per dose “**2**” is highlighted, and actuating the “+” soft function key **28** or the “-” soft function key **29** raises or lowers the highlighted number by one for each actuation, accordingly. FIG. **13(b)** illustrates the display after actuating the “+” soft function key **28** one time; the number of pills per dose is now “**3**” instead of “**2**” (“Take **3** pills **4** times per day”). Actuating the “Next” soft function key highlights the next setting (the frequency or doses per day) for modification, as illustrated in FIG. **13(c)**, and that setting is modified in the same manner.

[0089] The user can then set the dose times, by actuating the “Next” soft function key **27**, as illustrated in FIGS. **13(d)-13(f)**. Referring to FIG. **13(d)**, the first dose time and last dose time are displayed on the LCD **11**, with the first dose time highlighted. The first dose time is changed in 15 minute increments by actuating the “+” and “-” soft function keys **28** and **29**. The device automatically calculates the last dose time by adding 12 hours to the first dose time, and sets the intermediate dose times by dividing the 12 hour period by the scheduled number of doses per day. As illustrated in FIG. **13(e)**, actuating the “+” soft function key **28** one time increases the first dose time 15 minutes to “08:15 A”, and, as illustrated in FIG. **13(f)**, actuating the “+” soft function key **28** another time increases the first dose time another 15 minutes to “08:30 A”.

[0090] After setting the dose times, actuating the “Next” soft function key **27** allows for the modification of the refill amount, as illustrated in FIG. **13(g)**. The refill amount is highlighted on the LCD **11**, and the “+” and “-” soft function keys **28** and **29** increase and decrease the refill amount, accordingly.

[0091] Referring to FIG. **13(h)**, after completion of the “Medication Schedule—Program” mode, the device displays the new settings, and requests that the user verify them by actuating the “Yes” soft function key **27**. If the settings are incorrect, the user actuates the “No” soft function key **28**, and the device returns to the beginning of the “Medication Schedule—Program” mode.

[0092] Further, the mode soft function key 26 enables the user to modify certain device settings or program information (i.e. date and time of day settings, alarm volume, snooze interval, etc.).

[0093] The device tracks the number of pills in each compartment as the patient complies with scheduled medication alarms. From the passive mode, when the device figures that a medication compartment is empty, the device provides a "Refill" alarm to alert the patient that it is time to refill a medication compartment, as illustrated in FIGS. 14(a)-14(c). Referring to FIG. 16(a), upon the occurrence of a "Refill" alarm, the device displays the name and strength of the medication to be refilled in reverse video in the upper left corner of the LCD 11, along with a graphic representation of the medication 63. The device also indicates the number of pills to be refilled and displays an arrow pointing to the appropriate medication compartment (the medication compartment 34 associated with dedicated key 24).

[0094] The alarm continues until the user actuates the associated dedicated key 24. The device then allows the user to actuate the "Fill it now" soft function key 27, or the "Remind me later" soft function key 28, as illustrated in FIG. 14(b). If the user actuates the "Remind me later" soft function key 28, then the "Refill" alarm will occur at a pre-programmed future amount of time (the default is 2 hours). The "Refill" alarm will continue periodically until the user actuates the "Fill it now" soft function key 27, or unless the associated medication compartment is programmed to be empty. Actuating the "Fill it now" soft function key 27 redisplay the previous screen, and the associated medication compartment must be opened and closed to deactivate the "Refill" alarm. Once the associated medication compartment is opened and closed, the device prompts the user to verify the supply load, as illustrated in FIG. 14(c). If the user verifies the supply load by indicating "Yes", then the device will continue tracking the inventory of the associated medication compartment. Otherwise, if the user verifies the supply load by indicating "No", then the device disables the inventory tracking function for the associated medication compartment.

[0095] Referring to FIG. 10(a), the "Refill" mode can be selected by actuating the "Refill" mode soft function key 27, when the device is in the active mode (after actuation of the mode-select soft function key 26, from the passive mode). After user initiation of the "Refill" mode, the user must actuate the dedicated key associated with the medication compartment to be refilled, and may be prompted to do so by a message on the display. As illustrated in FIG. 15(a), the device then displays the name and strength of the medication to be refilled in reverse video in the upper left corner of the LCD 11, along with a graphic representation of the medication 63. The device also indicates the number of pills to be refilled and displays an arrow pointing to the appropriate medication compartment (the medication compartment 34 associated with dedicated key 24). Once the associated medication compartment is opened and closed, the device prompts the user to verify the supply load, as illustrated in FIG. 15(b). If the user verifies the supply load by indicating "Yes", then the device will continue tracking the inventory of the associated medication compartment. Otherwise, if the user verifies the supply load by indicating "No", then the device disables the inventory tracking function for the associated medication compartment.

[0096] In a further embodiment of the present invention, the medical monitoring device 5 provides for the use of a variable

capacity compartment tray and storage system that affords complete flexibility in the quantities and volumes of solid, liquid or aerosolized doses contained within the unit. The variable capacity compartment tray also provides for pre-loading, and pre-labeling of medications. Accordingly, when the patient exhausts a supply of medication in one tray, a second pre-loaded and pre-labeled tray can quickly and easily replace the exhausted tray.

[0097] As illustrated in FIG. 16, the medical monitoring device 5 includes a removable tray 75 that can easily be inserted and removed. The tray 75 contains the medication compartments 31-35. The tray 75 has extensions 77 protruding from each side that insert into corresponding slots 78 in the top portion 85 of the device 5. The tray 75 is a predetermined depth (a). A tray 76, as shown in FIG. 17, can be of a different predetermined depth (b). The differing depths provide for variable quantities, volumes and types of medications necessary for a given treatment regimen.

[0098] The predetermined depth is based on functionality. The compartments of a particular tray must be capable of storing doses of different types of medication covering a certain time period. For instance, each compartment of one size tray may be designed to store 84 tablets of a medication provided in a tablet size of 1 centimeter in diameter by 0.5 centimeters thick. The tray could store a week's supply of such a medication, where three pills are prescribed to be taken four times a day. In addition to the one medication, another compartment of the same tray could store a larger supply of another medication provided in a smaller tablet size. Various size trays can be provided, each capable of storing a number of different combinations of different medications subject to different prescription schedules and covering various time periods. Further, a tray 79 can contain compartments capable of storing a canister 80 for a medication in the form of an inhalant, a container 81 for a medication in the form of a liquid, or pre-loaded syringes 82 for medication taken by injection, as illustrated in FIG. 18. Additionally, as illustrated in FIG. 19, the tray 75 can be of a depth that accommodates a medication bottle 83 as dispensed by a pharmacist. Additionally, trays or compartments can provide direct storage of liquid, injectable, or aerosolized medications.

[0099] The trays of varying sizes are provided to accommodate various volumes of multiple solid dose medications. For example, at one time the user might wish to have a compact design for maintaining a one to three day supply of medication. At another time the user might be traveling for an extended period of time, and thus would require a larger volume tray for accommodating a week's supply or longer of various medications. The user could then replace the compact tray with a larger volume tray containing a larger supply of medication. The device of the present embodiment thereby provides flexibility to meet the particular requirements of the user at any given time.

[0100] Each tray includes a mechanism for attaching to the top portion 85 of the device 5, which houses the electronics and user interface. The attaching mechanism can be any mechanical device suitable for easy insertion of the trays into, and removal of the trays from, the medical monitoring device. Such mechanisms are within the purview of ones reasonably skilled in the art

[0101] Each tray can be independently labeled by the pharmacist, with labels being placed on a top lid for each compartment within the tray, as shown in FIG. 20. Additionally, or alternatively, labels could be placed on the underside of the

top portion **85** of the device, as shown in FIG. **21(b)**, which is a view in the direction X of the device **5** as depicted in FIG. **21(a)**.

[0102] In a further embodiment, as illustrated in FIG. **22**, the tray **75** accommodates a series of liners **86** that fit into each compartment. Each liner holds a prepackaged unit dosage of medications. This embodiment enables the pharmacist to fill, seal and label the liners, so that the user then need only insert a full liner in its respective compartment in the tray **75**. Additionally, the label can be reused by peeling it off the liner **86** and placing it on the lid for the respective compartment (as shown in FIG. **20**) or placing it on the underside of the top portion **85** of the device (as in FIG. **21(b)**).

[0103] The tray and labeling mechanism provides for increased accuracy and efficiency, and reduces errors occurring when patients reload the medical monitoring device.

[0104] In a further embodiment, as illustrated in FIG. **23**, the top portion **85** of the device includes a frame or support cover **87** that is connected by a hinge mechanism. The frame or support cover **87** unlatches from the top portion **85** and rotates in the direction of the arrow Y, allowing for insertion of the tray **75**. The frame or support cover **87** then rotates back and latches into the top portion **85**, holding the tray **75** within the device.

[0105] In a further embodiment of the present invention, as illustrated in FIG. **3**, an electronic cradle **70** is provided for mounting the device **5** to facilitate automatic communications, programming and uploading. The cradle includes an interface **72** capable of transmitting data to, and receiving data from, the communications port **17**. The cradle further includes a modem device **73**. The cradle's modem device **73** can be programmed to automatically dial certain numbers at certain times and connect to remote devices, or be instructed to do so by the medical monitoring device. Once connected to a remote device, the cradle then provides patient identification information to the remote device, and either downloads programming data from the remote device, or uploads user response data to the remote device, or performs both downloading and uploading, automatically. The present invention thereby provides health care providers with the ability to automatically download a program to the patient's device, and upload information concerning the patient's treatment progress, including data reflecting compliance with prescribed treatment, from a remote location.

[0106] In a further embodiment, the present invention provides a method and means for wireless communication with and polling of the medical monitoring device. Referring to FIG. **1**, the medical monitoring device includes a receiver-transmitter **8** connected to the microcontroller **10**, and an antenna **7** connected to the receiver-transmitter **8** for receipt and transmission of wireless communication signals. The wireless communication may be by a cellular telephone link, satellite link, or other radio communication means, commonly known to those of ordinary skill in the art of electronic communications.

[0107] The wireless method and means of the present embodiment provides for the transmission of treatment data from a remote device **100** to the medical monitoring device, real-time monitoring of the progress of a treatment regimen being administered, and real-time monitoring of elements of a patient's health and physical status, as illustrated in FIGS. **1** and **24**. The real-time monitoring facilitates various tasks including, conducting a health status assessment, monitoring adverse effects or side effects experienced by the patient,

monitoring treatment progress, monitoring physiologic data from serum or urine, monitoring events at the cellular, molecular and endocrine levels, and assessing the patient's general quality of life. The device is capable of receiving treatment information continuously, periodically, and upon demand by a health care provider.

[0108] Once the treatment information is received by the medical monitoring device, the device executes an interaction with the patient. The interaction may comprise any one or combination of the following: (1) educational information concerning the patient's health status, treatment progress, or other information relating to the disease(s) being treated and the treatment regimen being administered; (2) instructions to the patient (i.e., instructing the patient to modify medication dosage or schedule, instructing the patient to schedule a visit, or instructing the patient to go to the emergency room); or (3) patient, monitoring, and query data. The treatment information may further comprise any other data relating to any aspect of the patient's health or general quality of life.

[0109] In the case where the treatment information comprises patient query data, once the patient query data is transmitted to the medical monitoring device, the device either promptly executes the Patient Query mode, or stores the patient query data for subsequent execution of the Patient Query mode, depending on the status of an execution command. The execution command is either transmitted with the patient query data or stored in the medical monitoring device. The execution command is set or established by a healthcare provider, or by the device itself through artificial intelligence means, and depends upon the urgency of receiving responses to the particular queries transmitted to the device. The timing associated with the execution command is based on the disease being treated and the treatment regimen being administered. For example, if patient query data relates to a congestive heart failure condition, or if the device receives data from sensors monitoring blood pressure, EKG, cellular, molecular, and/or endocrine events related to heart function; with examples including heart rate, blood pressure, sugar level, pO₂, pH, ketones, anemia, blood, serum, urine, Ca⁺⁺, K⁺, Na⁺, etc; then the healthcare provider might set the execution command for immediate transmission of the response data. On the other hand, the patient query data may have been previously stored in the medical monitoring device (i.e., during initial programming of the device for a particular treatment regimen). After the medical monitoring device executes the Patient Query mode, the resulting response data is either stored in the medical monitoring device for subsequent transmission, or promptly transmitted to the remote device **100** for storage and analysis. The timing of the transmission of the response data depends on an execution command, as described above.

[0110] Alternatively, the medical monitoring device analyzes the response data by comparing it to target data transmitted with the query data, or target data previously stored in the medical monitoring device. Then, if the device determines that the response data meets certain predefined criteria, the device promptly transmits the response data to the remote device **100** for storage and analysis by the healthcare provider. The predefined criteria are set or established by a healthcare provider, and depend upon the treatment being administered and the particular response data being analyzed.

[0111] For example, if the disease being treated is a congestive heart failure condition, and a single response data point indicates that the patient is suffering moderate or severe

chest pain, then the device will immediately transmit the response data to the healthcare provider. As another example, if a combination of response data points indicate that the patient is suffering from moderate shortness of breath in combination with mild leg swelling, then the device will immediately transmit the response data to the healthcare provider. As a further example, if a sequence of response data points indicates that the patient has been suffering from moderate shortness of breath, and subsequently experiences a rise in blood pressure to a systolic level of over 160 mm mercury, then the device will immediately transmit the response data to the healthcare provider based upon the sequence of events experienced by the patient and entered into the device. The same example applies to data points indicating heart rate, blood pressure, sugar level, pO₂, pH, ketones, anemia, blood, serum, urine, Ca⁺⁺, K⁺, Na⁺, etc., as specified above.

[0112] The criteria may comprise target data from which the response data should not deviate, a template with which the response data is compared, or any other method for analyzing the response data in view of some predefined base-line or range of values. Further, the response data that triggers a prompt or immediate transmission may comprise a single data element, a particular sequence of data elements, or a particular combination of data elements, as described in the examples above. The timing of the transmission depends on the disease being treated and the treatment regimen being administered, and is set or established by the healthcare provider accordingly, also as described above. Therefore, a particular health outcome, or health outcomes, will determine the timing and informational content of the transmissions. In this fashion, the outcome of medical treatment can be monitored and analyzed, compared to normative, targeted, or desired goals of treatment, and deviations from the norms or targets can trigger a modification of the monitoring of the patient as well as the treatment regimen itself.

[0113] Additionally, when the data is transmitted to the remote device **100** for analysis, a healthcare provider may not be available to respond to the data. The response data, however, potentially represents an aspect of the patient's condition that would mandate critical and prompt or immediate review, so that prompt action could be taken to examine the patient, further query the patient, change the patient's treatment regimen, or instruct the patient to go to the emergency room. In such a situation, the remote device **100** executes an algorithm that analyzes the response data alone or in combination with previously transmitted data, and promptly transmits a message to a device carried by the healthcare provider or to the healthcare provider's answering service. Again, the algorithm is developed by a healthcare provider and depends upon the particular disease(s) being treated and treatment regimen being administered. The patient and healthcare provider are thereby linked, via a wireless means, through a series of two or more devices, each of which contains algorithms that analyze information and determine the appropriate timing and content of information communicated to the healthcare provider concerning the patient's health status.

[0114] The remote device **100** is also capable of performing a polling feature whereby it polls the medical monitoring device and retrieves desired information. The desired information retrieved by the remote device may include: (1) response data; (2) physiologic data; (3) data related to cellular, molecular, and endocrine or metabolic mechanisms, as specified above; (4) data concerning the patient's adherence to a medical treatment regimen; and/or (5) any other data

relating to any aspect of the patient's health or general quality of life. The remote device **100** polls the medical monitoring device by communicating via a wireless means, and retrieves the desired information from the medical monitoring device's memory. In cases where a patient requires specialized attention or treatment, the polling feature provides for continuous, periodic, spontaneous, and/or random monitoring of treatment progress by the health care provider. An algorithm analyzes previous data captured by the medical monitoring device and determines whether the polling will be by continuous, periodic, spontaneous, and/or random monitoring. Through the polling feature, health care providers can monitor seriously ill patients outside the hospital, almost as if they were receiving bedside monitoring in the hospital. Moreover, in cases where the patient's treatment regimen includes an "unforgiving" medication that must be taken according to precise schedules and quantities to avoid dire clinical problems, the polling feature provides the health care provider with the ability to remotely, yet closely, monitor health status data and compliance with treatment regimens.

[0115] In appropriate cases (based on the particular requirements of the treatment regimen being administered), physiologic, cellular, molecular, endocrine and/or metabolic events can be assessed and monitored, and resulting data is transferred to the medical monitoring device from remote monitors **106** and/or sensors **107**, as illustrated in FIG. 24; or the medical monitoring device itself assesses and monitors such events. The remote monitors **106** and sensors **107** can be linked to the medical monitoring device directly or by a wireless means, as illustrated in FIG. 24. The resulting data is either stored in the medical monitoring device for subsequent transmission (i.e., during a subsequent polling operation), or promptly transmitted to the remote device **100** for storage and analysis. As described above, the timing and content of the transmission of the resulting data depends on the events or data monitored, or information generated therefrom, the disease being treated and the treatment regimen being administered, and is set or established by a healthcare provider accordingly.

[0116] Alternatively, the medical monitoring device analyzes the resulting data by comparing it to target data. Then, if the device determines that the resulting data meets certain predefined criteria, the device promptly transmits the resulting data to the remote device **100** for storage and analysis by the healthcare provider. The predefined criteria are set or established by a healthcare provider, and depend upon the treatment being administered and the particular data being analyzed, as described above. The criteria may comprise target data from which the resulting data should not deviate in a given manner, a template with which the resulting data is compared, or any other method for analyzing the resulting data. Further, the resulting data that triggers a prompt transmission may comprise a single data element, a particular sequence of data elements, or a particular combination of data elements. The timing or immediacy of the transmission also depends on the disease being treated and the treatment regimen being administered, and is set by the healthcare provider accordingly. The events being assessed and monitored may include, but are not limited to, EEG, EKG, blood pressure, pulse, temperature, blood glucose level, and/or cellular, molecular, and endocrine or metabolic events, as specified above. The end result is the ability to analyze and correlate physiologic and physical data, medication compliance data, and health status assessment data, and develop a complete

picture of the patient's health and treatment progress. Following the analysis, prompt transmission of new information, patient queries, sensor or monitoring device queries, or instructions then alter the treatment regimen in real-time with respect to monitored events.

[0117] The wireless communication feature provides improvements over the prior art in that a medical monitoring device with such a feature does not necessarily require a memory storage function. The wireless communication feature also facilitates continuous, periodic, spontaneous, and/or random data transmission or polling of data related to the patient's treatment regimen and health status. The wireless communication feature thereby enables a varying degree of frequency and intensity in monitoring a patient's health status and treatment progress, including variation in the types of data transmitted and monitored, and enables monitoring at a level that provides real-time interaction with outpatients. Further, the wireless communication feature provides for prompt data transfer where the patient's condition warrants prompt attention. The wireless communication feature thereby allows for outpatient treatment of seriously ill patients, to keep them out of hospitals and nursing homes, with more independence, and less health care expense.

[0118] Further, with the present invention, seriously ill outpatients can be treated by a team of professionals that may include one or more physicians, a case manager, a visiting nurse, a physical therapist, a personal emergency response center, psychiatrist, etc. This team is analogous to a "code blue" team, a surgical team, or other type of healthcare team for inpatient care. While the device of the present invention monitors different aspects of the patient's condition, it may become necessary that one or more of the team members be promptly notified about emerging aspects of the patient's physical state. Then, according to the results of algorithms that analyze monitored information concerning the patient's physical state, the medical monitoring device determines which team members to notify, the timing of such notification, and the appropriate data to convey; and transmits the data accordingly. The notification consists of the transmission of information concerning the patient's condition, and occurs either by a wireless communication or through a network of modems **102**, or other appropriate transmission method, as illustrated in FIG. 24.

[0119] For example, with regard to an outpatient with a congestive heart failure condition, when the device detects an increase in the patient's blood pressure of at least 30 mm mercury, an algorithm could provide that the device notify the patient's case manager of the developing circumstances. Further, if the increase in blood pressure is accompanied by chest pain, then the algorithm could provide that the device notify the patient's case manager and visiting nurse. Going one step further, if certain cardiac enzyme elevations, muscle receptor alterations, or other molecular changes are occurring, the algorithm could provide that the device notify the case manager, visiting nurse, and cardiologist. Finally, if the patient also increases nitroglycerin tablet intake, the algorithm could provide that the device notify a nearby emergency response center and request the dispatch of an ambulance, in addition to notifying the above mentioned healthcare providers.

[0120] As part of the process of moving patient care from the hospital and doctor's office, into the home and ambulatory setting, we have previously described a patient monitoring system that includes a medication monitor that monitors medical treatment, medication use, patient health status, and

quality of life; monitors that are external, or implanted, that monitor physiologic functions including but not limited to temperature, pulse, EKG, and PO₂; and external or implanted monitors that monitor hormone levels, ions, cellular mechanisms and molecular events. Algorithms developed by healthcare professionals were described that would determine how, when, where, and with what degree of urgency the data from the monitors would be transmitted to the health caregivers.

[0121] The present invention further provides algorithms that function like a physician conducting a clinical examination. Algorithms within the device determine when events should be monitored, which events to monitor, how those events should be monitored, and the particular monitors and monitoring sequence employed. As illustrated in FIG. 24, the monitoring is accomplished through a system of monitors **106** and sensors **107** interfaced with the medical monitoring device either by a direct connection, or by a wireless means. The algorithms then analyze the data collected, and determine the urgency of communicating the results of the analysis and coordinate such communications, as described above.

[0122] For example, in monitoring and treating the patient with congestive heart failure condition, a medication use monitor, clinical health status monitor, blood pressure monitor, pulse oximetry monitor, EKG monitor, implanted or external blood and serum monitors (to monitor physiologic and cellular events), and other external or implanted monitors, are applied to the patient. The various monitors interface with the medical monitoring device, which contains a series of algorithms for analyzing data collected from the monitors and coordinating the appropriate treatment and communication procedures. The monitored data, for example, may indicate an increased use of nitroglycerin tablets and increased blood pressure. An algorithm analyzes the data and activates the pulse oximetry monitor, which shows reduced oxygen in the blood. The analysis triggers another algorithm that activates the EKG monitor, and activates serum monitors to monitor for cardiac enzyme elevations indicative of heart muscle damage. A further algorithm analyzes the data from all the monitors and determines a heart attack is underway. The medical monitoring device then activates a medication discharge device that administers a drug to block the heart attack, and facilitates notification of all the pertinent healthcare providers and ambulance service. While waiting for the ambulance, the medical monitoring device continues to monitor the data from the monitors, transmit data to the healthcare providers, and continues the administration of additional drugs, and titrate the dosing of the drugs based upon monitored events that relate to blood levels of the drug, degree of heart muscle damage, degree of chest pain experienced by the patient, etc.

[0123] In addition to activating monitors singly, in sequence, or in combination based upon the analyzed data, the medical monitoring device may contain additional algorithms that regulate other functions. For example the algorithms could regulate the duration of monitoring the patient by one or more monitors. One such algorithm could determine and control the specific tests administered by a particular monitor.

[0124] In a further embodiment of the present invention, the medical monitoring device itself, in addition to storing and executing the algorithms, contains the monitors for performing the necessary monitoring and testing for analyzing the

patient's medication use, health status, quality of life, physiologic status, cellular function, hormone levels, receptor levels, ions, cell counts, etc.

[0125] Accordingly, the medical monitoring device continuously analyzes data coming in from certain monitors, and continuously alters the selection, combination, timing, duration, sequencing, and activation of monitors to most effectively monitor and treat the patient's condition in real-time. The medical monitoring device further controls the communication of information to the healthcare treatment team, to create a seamless and integrated monitoring and communication system. Through a series of patient monitors, software-driven algorithms, and communications linkages to healthcare professionals, the present invention provides a real-time patient event-monitoring system that automatically conducts clinical examinations that are continuously modified and refined based upon the patient's real-time clinical needs.

[0126] In a further embodiment, the present invention provides a medical monitoring method and apparatus that carries out real-time monitoring of a patient's health status and automatic modification of a treatment regimen. The medical monitoring device monitors patient data relating to one or more physical attributes of the patient, and analyzes that data in accordance with an algorithm stored in the medical monitoring device. The medical monitoring device then provides instructions to the patient, or modifies the patient's treatment regimen, when the analysis reveals that the physical attributes meet certain predefined criteria. As described above, the predefined criteria are set or established by a healthcare provider, and depend on the disease(s) being treated and treatment regimen being administered.

[0127] For example, if the medical monitoring device monitors certain conditions or events, or receives response data, indicative of a congestive heart failure condition, then the device would instruct the patient to take certain medications, go to the emergency room, or modify the patient's treatment regimen (i.e., medication schedule), accordingly. The algorithm is developed by a healthcare provider, and executes an analysis (i.e., decision tree analysis) that results in different actions depending on the monitored conditions or events.

[0128] Other anticipated medical conditions include diabetes, renal or kidney disease, liver disease, hypertension, endocrine imbalance, cancer, and lung and heart disease. Also included are viral, bacterial and fungal diseases, and antigens associated with specific human pathogens (i.e., if the patient is on antibiotics, a healthcare provider will monitor whether the organism becomes resistant and increases in number).

[0129] In a further embodiment the present invention provides functionality like that of a nervous system or neuroregulatory system, paralleling, for example, the neuroendocrine system. In the human neuroendocrine system, sensors in the brain monitor a variety of physiologic and hormonal processes, and then activate glands to release varying levels and types of hormones and peptides to maintain homeostasis in the body. The system is linked together via neural pathways, and a feedback loop system. Common to many disease-states is a disruption of physiologic processes that serve to cause or worsen the underlying disease-state, whereby the effects of the disruption require correction as part of the disease treatment. A classic example is the hypothalamic-pituitary-thyroid axis, wherein the brain normally senses the amount of circulating thyroid hormone and, based upon the levels of thyroid sensed by the hypothalamus in the brain, increases or

decreases the output of thyroid hormone by the thyroid gland. With a thyroid disease, however, the thyroid gland does not properly respond to the brain's regulatory signals, and outputs too much or too little hormone independent of the brain's commands.

[0130] Accordingly, as illustrated in FIG. 24, the present embodiment provides a single medical monitoring device 5, or a system of monitoring devices 106, that interfaces with systems of sensors 107 that may be external to or implanted within the patient. Different sensors are responsible for monitoring different processes in the body, and are designed to communicate with one another via wireless means, or by a direct connection. For example, one sensor might be responsible for monitoring circulating peptide, molecular, ionic, and hormone levels in the blood, and additional levels, such as glucose, potassium, and oxygen (pO₂) levels. A second sensor might be responsible for monitoring heart function. A third sensor would monitor pulmonary (lung) function. A fourth sensor would monitor blood pressure. Additional sensors would monitor additional processes.

[0131] In addition, a variety of pharmaceutical, hormone, nutraceutical, and other supplementation delivery devices 108, linked with the system of sensors and the monitoring device(s), deliver appropriate types and quantities of pharmaceuticals, hormones, nutraceuticals, and other supplements based upon processes and levels monitored by the sensors. The medical monitoring devices include algorithms that control the release of the supplementary and pharmaceutical substances from the delivery devices, based on an analysis of the data collected by the system of sensors.

[0132] The algorithms determine and control the activation of particular sensors at particular times or during particular time intervals, and the communication between particular sensors, including the timing of such communications, the nature and type of communication, and the type of information communicated. The overall system is integrated and coordinated to monitor physiologic processes related to the patient's disease state(s). The monitors function like a "brain", controlling the monitoring processes and the delivery of supplements. They compare the monitored processes and levels to normative physiologic values, determined and pre-programmed into the monitors by healthcare professionals, and then effectuate a series of treatments to restore homeostasis. The algorithms are designed to function like the neuroregulatory systems of the brain, analyzing monitored data, comparing the monitored data to predetermined norms, and effectuating outputs in the form of treatments delivered to the patient, further diagnostic tests, alerts issued to healthcare professionals, and other remedial functions.

[0133] A central medical monitoring device 105 implanted within the patient, or remote from the patient, performs a polling function as described in detail above, whereby it periodically polls the system of sensors and monitors via a wireless means to obtain the monitored data. The central monitor 105 functions as command and control center, governing and regulating all of the above processes. The central monitor 105 also performs diagnostics on the other monitors 5 and 106, sensors 107, and delivery devices 108, and, if a malfunction is detected, the central monitor 105 analyzes the malfunction and either corrects it and/or notifies the appropriate healthcare professional. The present embodiment enables the replacement of defective systems of the body by a system of sensors and monitoring devices linked to a central medical monitoring device.

[0134] For example, a patient may be attached to a glucose monitor that monitors glucose levels in the blood and reports them to the central medical monitoring device via wireless transmission, or when the central device polls the glucose monitor's memory for stored levels of glucose. Upon receiving the data representing glucose levels, the central device executes an algorithm that compares the levels to normative values. When the glucose levels are within the range of normative values, the central monitor determines that no treatment is necessary. When the reported glucose levels are outside the range of normative values, the central device instructs the patient to administer an injection with additional insulin, or eat a piece of fruit or candy bar, depending upon whether the glucose levels are too high or too low, respectively. Alternatively, the central device activates an implanted insulin pump to release insulin into the patient's bloodstream, and/or contacts a healthcare professional that the patient is in danger.

[0135] Through this wireless system that maintains homeostasis, the patient's defective systems are replaced or supplemented by a wireless monitoring and therapeutic system, that establishes appropriate feedback loops and algorithms, to optimize health outcomes outside of a hospital setting.

[0136] In a further embodiment of the present invention, the central monitor links up with one or more databases **109** for: (1) better analyzing the inputted data from the peripheral sensors and monitors; (2) downloading appropriate information from the databases and communicating that information to the patient; (3) applying database information to deploy and control other monitors; and (4) applying database information to deliver medical treatment and medication.

[0137] For example, a glucose monitor attached to a patient transmits data indicating the patient's glucose level to the central monitor, at selected time intervals and via a wireless means. The central monitor also periodically polls an insulin administration monitor to receive data indicating the date, time, and dosing amount of the patient's insulin medication. The central monitor then polls a diabetes disease management database to access and/or download algorithms that, when applied to analyze the glucose data levels and insulin dosing levels, provide new instructions for the patient about insulin dosing and glucose monitoring. Further, the central monitor accesses a nutrition database, downloads new dietary instructions, and communicates the new insulin instructions and dietary instructions to the patient.

[0138] When further monitoring reveals a glucose level that is dangerously high, posing a risk for the development of a hyperglycemic coma, the central monitor again polls the diabetes disease management database, and accesses algorithms that determine the need for cardiovascular monitoring. The central monitor then initiates blood pressure and cardiac status monitoring. The central monitor receives data concerning the patient's cardiac status, and again accesses the diabetes disease management database algorithms which determine that the next insulin dose should be increased by 50%. The central monitor communicates the new dosing instructions to the patient.

[0139] Alternatively, the peripheral system of monitors, sensors, and delivery devices are preferably equipped with the ability to access the databases themselves and directly communicate between one another, thereby bypassing the central monitor. This provides a backup system, should the central monitor fail, or should such an alternative be more desirable based on cost, portability, efficiency, or other factors.

[0140] The present invention, by linking a variety of patient monitors and sensors with one another, and with various databases; and by providing a series of algorithms that analyze monitored data, combined with information from the databases; and by initiating various treatment functions (i.e., communicating treatment information to the patient or administering doses through attached medication delivery systems) based on the results of algorithm-based data analysis; provides for real-time patient monitoring and management of health status, independent of or in conjunction with the healthcare professional. The system also takes advantage of continuously updated databases and knowledge systems, that can be used to guide treatment of the patient's condition in real-time, to optimize the monitoring and management of disease.

[0141] Of course, it should be understood that a wide range of modifications can be made to the exemplary embodiments described above. A multitude of different algorithms may be developed that provide for prompt transmission of patient data should a single data element, sequence of data elements, or combination of data elements concerning the patient's health status be entered into or monitored by the medical monitoring device. It is therefore intended that the foregoing detailed description be regarded as illustrative rather than limiting, and that it be understood that the following claims, including all equivalents, are intended to define the scope of the present invention.

1-58. (canceled)

59. A method for performing real-time monitoring of health status using a medical monitoring device capable of transmission of data to a remote device either wirelessly or via a wire, wherein the method comprises the steps of:

- (a) operating the medical monitoring device in a query mode to obtain query data, wherein the query data comprises first data pertaining to treatment progress, or tracking compliance with a medication schedule, or operating the medical monitoring device in the query mode to obtain query data, wherein the query data comprises first data pertaining to treatment progress and tracking compliance with the medication schedule; and
- (b) providing one or more instructions or messages, or instructions and messages, using audible signals, or visible signals, or audible signals and visible signals.

60. The method of claim **59**, wherein the one or more instructions or messages comprise one or more types of signals selected from the group consisting of music, melody, sounds conveying a message, speech, symbols, and pictures.

61. The method of claim **59**, wherein the query mode obtains query data using one or more types of signals selected from the group consisting of sounds conveying a message, speech, symbols, and pictures.

62. The method of claim **59**, wherein the query mode, or the one or more instructions or messages are presented as a graphic image.

63. The method of claim **62**, wherein the graphic images change by an algorithm within the medical monitoring device based upon adherence to a treatment regimen.

64. The method of claim **59**, wherein the remote device downloads programming data into the medical monitoring device.

65. The method of claim **59**, whereby the remote device transmits treatment data into the medical monitoring device either wirelessly or via wire transmission.

66. The method of claim **59**, whereby the query mode may present additional queries, based upon the type of first data entered.

67. A method for performing real-time monitoring and treatment of health status using a medical monitoring device comprising:

- (a) one or more networked external sensors or monitors, networked implanted sensors or monitors, or networked external and implanted sensors or monitors, to monitor health status thereby creating monitoring data,

wherein a medical monitoring device provides one or more input devices that monitor at least one physical attribute and transfers either wirelessly or via wire first data related to the monitored physical attributes to a local device medical monitoring device, or to a remote medical monitoring device, or to a local medical monitoring device and to a remote medical monitoring device.

68. The method of claim **67**, wherein the medical monitoring device further comprises:

- (b) an external medication delivery device, implanted medication delivery device, or external and implanted medication delivery device, to treat the health status by delivering a treatment into a body in response to monitoring data from one or more monitors.

69. The method of claim **67**, wherein the treatment delivered comprises one or more types of treatments from a group consisting of pharmaceuticals, hormones, nutraceuticals, and supplements.

70. The method of claim **67**, wherein the monitoring data is compared to normative data to determine whether the treatment should be delivered.

71. The method of claim **64**, wherein said programming data or treatment data is transmitted from a database into the medical monitoring device either wirelessly or via wire transmission.

72. The method of claim **65**, wherein said programming data or treatment data is transmitted from a database into the medical monitoring device either wirelessly or via wire transmission.

73. A method for performing real-time monitoring of health status using a medical monitoring device capable of transmission of data to a remote device either wirelessly or via wire transmission, wherein the method comprises the steps of:

- (a) operating the medical monitoring device in a query mode to obtain query data, wherein the query data is inputted into the medical monitoring device during the patient query mode, and wherein the query data comprises first data pertaining to treatment progress, or tracking the compliance with a medication schedule, or operating the medical monitoring device in the query mode to obtain query data, wherein the query data is inputted into the medical monitoring device during the query mode, and wherein the query data comprises first data pertaining to treatment progress and tracking the patient's compliance with the medication schedule;
- (b) promptly executing a command that requires immediate execution, wherein the command is executed by the medical monitoring device based on the query data obtained during the query mode; and
- (c) storing the query data in the medical monitoring device for subsequent execution of the command when the execution command does not require immediate execution.

74. The method of claim **73**, further comprising the step of: (d) using the medical monitoring device to execute an interaction based on the first data pertaining to treatment progress, wherein the interaction generates resulting data, wherein the resulting data comprises one or more types of data selected from the group consisting of response data provided during the query mode of the medical monitoring device, data concerning the adherence to a medical treatment regimen, data concerning physical health, data concerning physiological status, data concerning cellular functions, data concerning molecular events, and data concerning endocrine and metabolic events.

75. The method of claim **74**, further comprising the step of: (e) promptly transmitting either wirelessly or via wire transmission at least a portion of the resulting data from the medical monitoring device to a remote device via transmission means when the execution command requires immediate transmission, and storing the response data in the medical monitoring device when the execution command does not require immediate transmission.

76. The method of claim **74**, further comprising the step of: (e) comparing the resulting data with target data, and, when the resulting data meets certain predefined criteria, promptly transmitting either wirelessly or via wire transmission at least a portion of the resulting data from the medical monitoring device to a remote device via the transmission means.

77. A method for performing real-time monitoring of health status using a medical monitoring device capable of transmission of data to a remote device either wirelessly or via wire transmission, wherein the method comprises the steps of:

- (a) operating the medical monitoring device in a query mode to obtain query data, wherein the query data is inputted into the medical monitoring device during the query mode, and wherein the query data comprises first data pertaining to treatment progress, or tracking the compliance with a medication schedule, or operating the medical monitoring device in the query mode to obtain query data, wherein the query data is inputted into the medical monitoring device during the query mode, and wherein the query data comprises first data pertaining to treatment progress and tracking the compliance with the medication schedule;
- (b) using the medical monitoring device to execute an interaction based on the first data pertaining to treatment progress, wherein the interaction generates resulting data, and the resulting data comprises one or more types of data selected from the group consisting of response data provided during the query mode of the medical monitoring device, data concerning the adherence to a medical treatment regimen, data concerning physical health, data concerning physiological status, data concerning cellular functions, data concerning molecular events, and data concerning endocrine and metabolic events;
- (c) promptly transmitting either wirelessly or via wire transmission at least a portion of the resulting data from the medical monitoring device to a remote device via a transmission means when an execution command requires immediate transmission, wherein the execution

command is executed by the medical monitoring device based on the query data obtained during the query mode; and

- (d) storing the resulting data in the medical monitoring device when the execution command does not require immediate transmission.

78. The method of claim **77**, further comprising the step of:

- (e) comparing the response data with target data, and, when the response data meets certain predefined criteria, promptly transmitting either wirelessly or via wire transmission at least a portion of the response data from the medical monitoring device to the remote device via the transmission means.

79. The method of claim **78**, wherein the information retrieved from the medical monitoring device comprises one or more types of data selected from a group consisting of response data provided during a query mode of the medical monitoring device, data concerning the adherence to a medical treatment regimen, data concerning physical health, data concerning physiological status, data concerning cellular functions, data concerning molecular events, and data concerning endocrine and metabolic events.

80. A method for performing real-time monitoring of health status, using a medical monitoring device capable of communication with a remote device either wirelessly or via a wire, wherein the method comprises the steps of:

- (a) operating the medical monitoring device in a query mode to obtain query data, wherein the query data is inputted into the medical monitoring device during the query mode, and wherein the query data comprises first data pertaining to treatment progress, or tracking the compliance with a medication schedule, and operating the medical monitoring device in the query mode to obtain query data, wherein the query data is inputted into the medical monitoring device during the patient query mode, and wherein the query data comprises first data pertaining to treatment progress and tracking the compliance with the medication schedule;
- (b) monitoring second data relating to one or more physical attributes;
- (c) analyzing the first data and the second data in accordance with a first algorithm stored in the medical monitoring device; and
- (d) promptly transmitting information related to the second data, or the first data pertaining to treatment progress, or the second data and the first data, via a transmission means to the remote device either wirelessly or via wire transmission when the results of the analysis indicate that the analyzed data meets certain predefined criteria, wherein the transmitted information includes at least a portion of the first data or the second data.

81. The method of claim **67**, wherein the monitoring data comprises one or more types of data selected from the group consisting of response data provided during the query mode of the medical monitoring device, data concerning the adherence to a medical treatment regimen, data concerning physical health, data concerning physiological status, data concerning cellular functions, data concerning molecular events, and data concerning endocrine and metabolic.

82. The method of claim **67**, wherein the monitoring data comprises one or more types of data selected from the group consisting of temperature data, blood pressure data, heart rate data, heart rhythm data, electrocardiographic data, breathing rate data, and intracranial pressure.

83. The method of claim **67**, wherein the monitoring data is determined by assaying a bodily fluid selected from the group consisting of blood, blood serum, urine, saliva, and cerebrospinal fluid.

84. The method of claim **83**, wherein the assay of the bodily fluid determines a concentration of an indicator selected from the group consisting of a steroid hormone, a polypeptide hormone, a liver enzyme, a heart protein, a muscle protein, glucose, calcium, potassium, sodium, pH, pO₂, pCO₂, ketones, an antibody, a bacterial antigen, a viral antigen, a fungal antigen, a tumor antigen, Ca⁺⁺, K⁺, and Na⁺.

85. The method of claim **67**, wherein a remote device analyzes the monitoring data, transmitted either wirelessly or via wire transmission to the remote device, in accordance with an algorithm stored in the remote device, and promptly transmits either wirelessly or via wire transmission information relating to the first data or the second data to a second device via a transmission means.

86. The method of claim **80**, wherein the medical monitoring device provides one or more input devices that monitor at least one of the physical attribute and transfer the second data related to the monitored physical attributes to the medical monitoring device.

87. A method for performing real-time monitoring of health status and modification of a treatment regimen, using a medical monitoring device, wherein the method comprises the steps of:

- (a) operating the medical monitoring device in a query mode to obtain query data, wherein the query data is inputted into the medical monitoring device during the query mode, and wherein the query data comprises first data pertaining to treatment progress, or tracking the compliance with a medication schedule, or operating the medical monitoring device in the query mode to obtain query data, wherein the query data is inputted into the medical monitoring device during the patient query mode, and wherein the query data comprises first data pertaining to treatment progress and tracking the compliance with the medication schedule;
- (b) monitoring second data relating to one or more physical attributes;
- (c) analyzing the first data, or second data, or the first data and the second data, in accordance with an algorithm stored in the medical monitoring device;
- (d) modifying the treatment regimen when the results of the analysis indicate that the analyzed data meets certain predefined criteria; and
- (e) modifying the treatment regimen based on the first data pertaining to treatment progress.

88. A medical monitoring device capable of transmission of data either wirelessly or via wire transmission to a remote device for performing real-time monitoring of health status and administering a medical treatment regimen, wherein the medical monitoring device comprises:

- (a) a memory;
- (b) a display;
- (c) a controller, wherein the controller operates to control access of the memory and to control display of treatment messages on the display;
- (d) a receiver that receives data either wirelessly or via wire transmission from a remote device via a transmission means, wherein the receiver receives data relating to the health status and the medical treatment regimen, and the

data relating to the health status and the medical treatment regimen are stored in the memory; and

- (e) a plurality of keys operably connected to the controller, wherein the plurality of keys are operable to enable a query mode, wherein query data is inputted into the medical monitoring device via at least one key during the query mode, and wherein the query data comprises first data pertaining to treatment progress, wherein the medical monitoring device is operable using at least one key from the plurality of keys to track the compliance with a medication schedule and to record compliance data, wherein,

after receiving the data relating to the health status and the medical treatment regimen, the medical monitoring device promptly executes an interaction involving the medical monitoring device when an execution command requires immediate execution, wherein the execution command is executed by the medical monitoring device based on the query data obtained during the query mode, and the medical monitoring device stores the query data in the memory of the medical monitoring device for subsequent execution when the execution command does not require immediate execution.

89. The medical monitoring device of claim **88**, wherein the interaction generates resulting data relating to at least one physical attribute; and the medical monitoring device further comprises:

- (f) a transmitter that transmits the resulting data either wirelessly or via wire transmission to a remote device via the transmission means, and

the medical monitoring device promptly transmits at least a portion of the resulting data either wirelessly or via wire transmission to a remote device via the transmission means when the execution command requires immediate transmission, and stores the resulting data in the memory of the medical monitoring device when the execution command does not require immediate transmission.

90. The medical monitoring device of claim **89**, wherein the resulting data comprises one or more types of data selected from the group consisting of response data provided during the query mode of the medical monitoring device, data concerning the adherence to a medical treatment regimen, data concerning physical health, data concerning physiological status, data concerning cellular functions, data concerning molecular events, and data concerning endocrine and metabolic events.

91. The medical monitoring device of claim **89**, wherein the resulting data comprises one or more types of data selected from the group consisting of temperature data, blood pressure data, heart rate data, heart rhythm data, electrocardiographic data, and breathing rate data.

92. The medical monitoring device of claim **89**, wherein the resulting data is determined by assaying a bodily fluid selected from the group consisting of blood, blood serum, urine, and saliva.

93. The medical monitoring device of claim **92**, wherein the assay of the bodily fluid determines a concentration of an indicator selected from the group consisting of a steroid hormone, a polypeptide hormone, a liver enzyme, a heart protein, a muscle protein, glucose, calcium, potassium, sodium, pH, pO₂, pCO₂, ketones, an antibody, a bacterial antigen, a viral antigen, a fungal antigen, a tumor antigen, Ca⁺⁺, K⁺, and Na⁺.

94. The medical monitoring device of claim **89**, wherein the medical monitoring device compares the resulting data with target data, and, when the resulting data meets certain predefined criteria, the medical monitoring device promptly transmits at least a portion of the resulting data either wirelessly or via wire transmission to the remote device via the transmission means.

95. The medical monitoring device of claim **89**, wherein the medical monitoring device analyzes the resulting data in accordance with an algorithm stored in the memory, and promptly transmits information related to the resulting data either wirelessly or via wire transmission to a remote device via the transmission means when the results of the analysis indicate that the resulting data meets certain predefined criteria, wherein the transmitted information includes at least a portion of the resulting data.

96. The medical monitoring device of claim **89**, wherein the medical monitoring device interfaces with one or more input devices that monitor at least one physical attribute and transfers the resulting data to the medical monitoring device.

97. A medical monitoring device for performing real-time monitoring of health status and modification of a treatment regimen, wherein the medical monitoring device comprises:

- (a) a memory;
- (b) a display;
- (c) a controller, wherein the controller operates to control access of the memory and to control display of treatment messages on the display; and

(d) a plurality of keys operably connected to the controller, wherein the plurality of keys are operable to enable a query mode to obtain query data, wherein the query data is inputted into the medical monitoring device via at least one key during the query mode, and wherein the query data comprises first data pertaining to treatment progress, wherein the medical monitoring device is operable using at least one of the plurality of keys to track the compliance with a medication schedule and to record compliance data, wherein the medical monitoring device operates to monitor second data relating to one or more physical attributes, and to analyze the first data, or second data, or first data and second data, in accordance with an algorithm stored in the memory of the medical monitoring device, and to modify the treatment regimen when the results of the analysis indicate that the first data, or the second data, or the first data and the second data, meets certain predefined criteria, and to modify the treatment regimen based on the first data pertaining to treatment progress.

98. A medical monitoring device capable of transmission of data either wirelessly or via wire transmission to a remote device for performing real-time monitoring of health status and administering a medical treatment regimen, wherein the medical monitoring device comprises:

- (a) a memory;
- (b) a display;
- (c) a controller, wherein the controller operates to control access of the memory and to control display of treatment messages on the display; and

(d) a transmitter that transmits first data either wirelessly or via a wire to a remote device via a transmission means; and

(e) a plurality of keys operably connected to the controller, wherein the plurality of keys are operable to enable a query mode to obtain query data, wherein the query data

is inputted into the medical monitoring device via at least one of the plurality of keys during the query mode, and wherein the query data comprises data pertaining to treatment progress, wherein the medical monitoring device is operable using at least one of the plurality of keys to track the compliance with a medication schedule and to record compliance data,

wherein the remote device receives first information relating to the health status and second information relating to the adherence to the medical treatment regimen by polling the medical monitoring device and receiving the first information and the second information either wirelessly or via the wire via the transmission means.

99. The method of claim **73**, further comprising the step of:

(d) transmitting first data, or second data, or first data and second data, from the medical monitoring device either wirelessly or via wire transmission to a remote device via a transmission means.

100. The method of claim **73**, wherein the medical monitoring device is operable in a medication compliance mode to display information relating to the compliance with the medication schedule, and the method further comprises the step of:

(d) displaying information relating to the compliance with the medication schedule on a display of the medical monitoring device.

101. The method of claim **73**, further comprising the step of:

(d) employing a plurality of sensors to obtain second data, and transferring the second data from the plurality of sensors to the medical monitoring device.

102. The method of claim **73**, further comprising the step of:

(d) comparing the resulting data with target data, and, when the resulting data meets certain predefined criteria, promptly transmitting at least a portion of the resulting data from the medical monitoring device either wirelessly or via wire transmission to a remote device via the transmission means.

103. A method for performing real-time monitoring of a health status using a medical monitoring device capable of transmission of data to a remote device either wirelessly or via a wire, wherein the method comprises the steps of:

(a) monitoring health via one or more external sensors or monitors, implanted sensors or monitors, or external and implanted sensors or monitors, so as to create monitoring data;

(b) operating the medical monitoring device in a query mode to obtain query data, wherein the query data is inputted into the medical monitoring device during the query mode, and wherein the query data comprises first data pertaining to treatment progress, or tracking the compliance with a medication schedule, or operating the medical monitoring device in the query mode to obtain query data, wherein the query data is inputted into the medical monitoring device during the query mode, and wherein the query data comprises first data pertaining to treatment progress and tracking the compliance with the medication schedule;

(c) analyzing the first data, or the monitoring data, or the first data and the monitoring data, in accordance with an algorithm stored in the medical monitoring device or in a second device; and

(d) modifying the treatment regimen when the results of the analysis indicate that the first data, the monitoring data, or the first data and the monitoring data, meet certain predefined criteria.

104. The method of claim **103**, wherein the one or more external sensors or monitors, implanted sensors or monitors, or external and implanted sensors or monitors comprise a plurality of sensors that obtain second data, and the plurality of sensors transfer the second data to the medical monitoring device either wirelessly or via wire transmission, the monitoring data is created from the second data.

105. The method of claim **104**, wherein the plurality of sensors persistently monitor health or are actively polled for the second data so as to create the monitoring data.

106. The method of claim **104**, wherein the second data is selected from the group consisting of one or more of physiological data, cellular data, molecular data, endocrine data, and metabolic data.

107. The method of claim **103**, wherein the query data is configured as a survey.

108. The method according to claim **103**, further comprising the step(s) of:

(e) analyzing the first data, or the monitoring data, or the first data and the monitoring data, in accordance with another algorithm stored in the second device, wherein the second device communicates with the medical monitoring device, and wherein the second device analyzes the first data, or the monitoring data, or the first data and the monitoring data, and downloads a modified treatment regimen to the medical monitoring device.

109. The method according to claim **103**, further comprising the step(s) of:

(e) analyzing the first data, or the monitoring data, or the first data and the monitoring data, in accordance with another algorithm stored in a local medical monitoring device, or in a remote medical monitoring device, or in the local medical monitoring device and in the remote medical monitoring device, to triage the severity of an event detected by sensors of the medical monitoring device and thereby direct an appropriate level and type of medical care.

110. The method according to claim **103**, further comprising the step(s) of:

(e) analyzing the first data, or the monitoring data, or the first data and the monitoring data, in accordance with another algorithm stored in a local medical monitoring device, or in a remote medical monitoring device, or in the local medical monitoring device and in the remote medical monitoring device, to triage the severity of an event detected by sensors of the medical monitoring device and thereby direct an appropriate level and type of medical care.

111. The method according to claim **103**, further comprising the step(s) of:

(e) analyzing the first data, or the monitoring data, or the first data and the monitoring data, in accordance with another algorithm stored in a local medical monitoring device, or in a remote medical monitoring device, or in the local medical monitoring device and in the remote medical monitoring device, to triage the severity of an event detected by sensors of the medical monitoring device and thereby notify one or more appropriate medical care providers.

112. The method according to claim **103**, further comprising the step(s) of:

- (e) analyzing the first data, or the monitoring data, or the first data and the monitoring data, in accordance with the algorithm stored in the second device, wherein the second device comprises a local medical monitoring device, or a remote medical monitoring device, or both the local medical monitoring device and the remote medical monitoring device, to triage and to select data detected by the sensors of the medical monitor and to transmit data along with instructions specific to a medical provider's tasks, or to a medical care support provider's tasks, or to both the medical care support provider's tasks and to the medical care support provider's tasks.

113. The method according to claim **103**, further comprising the step(s) of:

- (e) analyzing the first data, or the monitoring data, or the first data and the monitoring data, in accordance with another algorithm stored in a local medical monitoring device, or in a remote medical monitoring device, or in the local medical monitoring device and in the remote medical monitoring device, to calculate patient health risk associated with the event detected by the sensors of the medical monitoring device and, thereby, direct modulation of a medical treatment regimen, or actuation of a medical delivery device, or both the modulation of the medical treatment regimen and the actuation of the medical delivery device.

114. The method of claim **103**, wherein during the query mode, activation of an "I Can't" response signals a microcontroller to display an appropriate message.

115. The method of claim **103**, wherein the query data is inputted into the medical monitoring device during the query mode via a query interface.

116. The method of claim **115**, wherein the query interface comprises one or more soft keys or one or more touch points or a combination of at least one soft key and at least one touch point.

117. The method of claim **103**, wherein the steps (c) and (d) occur contemporaneously with steps (a) and (b) so that modification of the treatment regimen occurs in real time and contemporaneously with the creation of monitoring data and with the input of query data into the medical monitoring device during the query mode.

118. The medical monitoring device of claim **103**, wherein the resulting data comprises one or more types of data selected from the group consisting of response data provided during the query mode of the medical monitoring device, data concerning the adherence to a medical treatment regimen, data concerning physical health, data concerning physiological status, data concerning cellular functions, data concerning molecular events, and data concerning endocrine and metabolic events.

119. The medical monitoring device of claim **103**, wherein the resulting data comprises one or more types of data selected from the group consisting of temperature data, blood pressure data, heart rate data, heart rhythm data, electrocardiographic data, breathing rate data, and intracranial pressure data.

120. The medical monitoring device of claim **103**, wherein the resulting data is determined by assaying a bodily fluid

selected from the group consisting of blood, blood serum, urine, saliva, and cerebrospinal fluid.

121. The medical monitoring device of claim **103**, wherein the assay of the bodily fluid determines a concentration of an indicator selected from the group consisting of a steroid hormone, a polypeptide hormone, a liver enzyme, a heart protein, a muscle protein, glucose, calcium, potassium, sodium, pH, pO₂, pCO₂, ketones, an antibody, a bacterial antigen, a viral antigen, a fungal antigen, a tumor antigen, Ca⁺⁺, K⁺, and Na⁺.

122. The method of claim **103**, further comprising the step of:

- (e) analyzing the first data, or the monitoring data, or the first data and the monitoring data, in accordance with another algorithm stored in a local medical monitoring device, or in a remote medical monitoring device, or in the local medical monitoring device and in the remote medical monitoring device, to triage the severity of an event detected by sensors of the medical monitoring device and thereby notify one or more persons in the proximity of the patient.

123. A medical monitoring device capable of transmission of data either wirelessly or via wire transmission to a remote device for performing real-time monitoring of health status and administering a medical treatment regimen, wherein the medical monitoring device comprises:

- (a) a memory;
- (b) a display;
- (c) a controller, wherein the controller operates to control access of the memory and to control display of treatment messages on the display;
- (d) a receiver that receives data either wirelessly or via wire transmission from a remote device via a transmission means, wherein the receiver receives data relating to the health status and the medical treatment regimen, and the data relating to the health status and the medical treatment regimen are stored in the memory; and
- (e) a plurality of keys operably connected to the controller, wherein one or more of the plurality of keys are operable to obtain information related to one or medications, or one or more diseases, or one or medications and one or more diseases.

124. A medical monitoring device capable of transmission of data either wirelessly or via wire transmission to a remote device for performing real-time monitoring of health status and administering a medical treatment regimen, wherein the medical monitoring device comprises:

- (a) a memory;
- (b) a display;
- (c) a controller, wherein the controller operates to control access of the memory and to control display of treatment messages on the display;
- (d) a receiver that receives data either wirelessly or via wire transmission from a remote device via a transmission means, wherein the receiver receives data relating to the health status and the medical treatment regimen, and the data relating to the health status and the medical treatment regimen are stored in the memory; and
- (e) a plurality of keys operably connected to the controller, wherein one or more of the plurality of keys are operable to obtain information related to why the patient is not taking his or her medication.

* * * * *

专利名称(译)	用于实时监测和管理患者健康状况和医疗方案的方法，装置和操作系统		
公开(公告)号	US20130218588A1	公开(公告)日	2013-08-22
申请号	US13/841285	申请日	2013-03-15
[标]申请(专利权)人(译)	MADRIGAL 健康		
当前申请(专利权)人(译)	MADRIGAL 健康，LLC		
[标]发明人	KEHR BRUCE A BENSON ROBERT H SOHN EVAN STARNES JAMES E MAURER DAVID STOWELL DAVIN CHAPMAN DEAN FARRAGE DAVID BAUMEL IRWIN D STEMPLER DAVID S		
发明人	KEHR, BRUCE A. BENSON, ROBERT H. SOHN, EVAN STARNES, JAMES E. MAURER, DAVID STOWELL, DAVIN CHAPMAN, DEAN FARRAGE, DAVID BAUMEL, IRWIN D. STEMPLER, DAVID S.		
IPC分类号	G06F19/00 A61B5/00 A61J7/04 G06Q50/00		
CPC分类号	A61B5/4839 A61J7/0481 A61J2007/0418 G06F19/3418 G06F19/3431 G06F19/3462 A61B5/0022 G06F19/3406 A61J2200/30 A61J2205/20 A61J2205/30 A61J2205/50 A61J2205/70 A61B5/743 A61J7 /0418 G16H20/13 G16H40/67 G16H50/30 G16H40/63		
优先权	60/040128 1997-03-07 US 60/044472 1997-04-18 US 60/051389 1997-07-01 US 08/924917 1997-09-08 US 08/955952 1997-10-22 US 60/068473 1997-12-22 US 10/492710 2005-08-05 US PCT/US1998/003933 1998-03-06 WO		
外部链接	Espacenet USPTO		

摘要(译)

提供了一种医学监测设备，操作系统和方法，用于管理用于治疗患者的医疗状况的医疗方案的管理。该设备存储与所管理的医疗方案有关的信息，包括药物计划数据，治疗数据，患者查询数据，患者响应数据，并且交互地向患者和医疗保健提供者提供信息。还提供了一种使用医疗监测设备执行患者健康状态的实时监测的方法和设备。相应地修改患者治疗方案的各个方面。医学监测设备还根据预定标准分析监测数据，并且可以将关于患者健康状态和治疗进展的信息迅速传达给通知医疗服务提供者的远程设备，并且可以基于分析结果修改患者的治疗方案。

