



US 20160045169A1

(19) **United States**

(12) **Patent Application Publication**  
**MAZAR et al.**

(10) **Pub. No.: US 2016/0045169 A1**

(43) **Pub. Date: Feb. 18, 2016**

(54) **INJECTABLE PHYSIOLOGICAL MONITORING SYSTEM**

**Publication Classification**

(71) Applicant: **MEDTRONIC MONITORING, INC.**,  
San Jose, CA (US)

(51) **Int. Cl.**  
*A61B 5/00* (2006.01)  
*A61B 5/0205* (2006.01)  
*A61B 5/042* (2006.01)

(72) Inventors: **Scott T. MAZAR**, Woodbury, MN (US);  
**Mark J. BLY**, Falcon Heights, MN (US)

(52) **U.S. Cl.**  
CPC ..... *A61B 5/7282* (2013.01); *A61B 5/0422*  
(2013.01); *A61B 5/4875* (2013.01); *A61B*  
*5/0205* (2013.01); *A61B 5/686* (2013.01); *A61B*  
*2562/04* (2013.01); *A61B 2562/0219* (2013.01);  
*A61B 2562/16* (2013.01); *A61B 2562/06*  
(2013.01); *A61B 5/1118* (2013.01)

(73) Assignee: **MEDTRONIC MONITORING, INC.**,  
San Jose, CA (US)

(21) Appl. No.: **14/921,827**

(57) **ABSTRACT**

(22) Filed: **Oct. 23, 2015**

An injectable device for use in a subcutaneous physiological monitoring of a patient includes a body, a plurality of sensors, and a monitoring unit. The plurality of sensors provide an indication of at least one physiological event of a patient, wherein the plurality of sensors includes two or more electrodes in contact with tissue of the patient. The monitoring unit is located within the body and is coupled to the plurality of sensors and configured to monitor a physiologic signal of the patient using the electrodes, wherein the physiologic signal includes an impedance signal related to hydration of tissue of the patient and wherein the monitoring unit is further configured to, based at least in part on the impedance signal measured from the patient, detect an impending cardiac decompensation of the patient.

**Related U.S. Application Data**

(63) Continuation of application No. 12/209,479, filed on Sep. 12, 2008, now Pat. No. 9,186,089.

(60) Provisional application No. 61/055,666, filed on May 23, 2008, provisional application No. 60/972,336, filed on Sep. 14, 2007, provisional application No. 60/972,537, filed on Sep. 14, 2007, provisional application No. 60/972,329, filed on Sep. 14, 2007, provisional application No. 60/972,354, filed on Sep. 14, 2007.

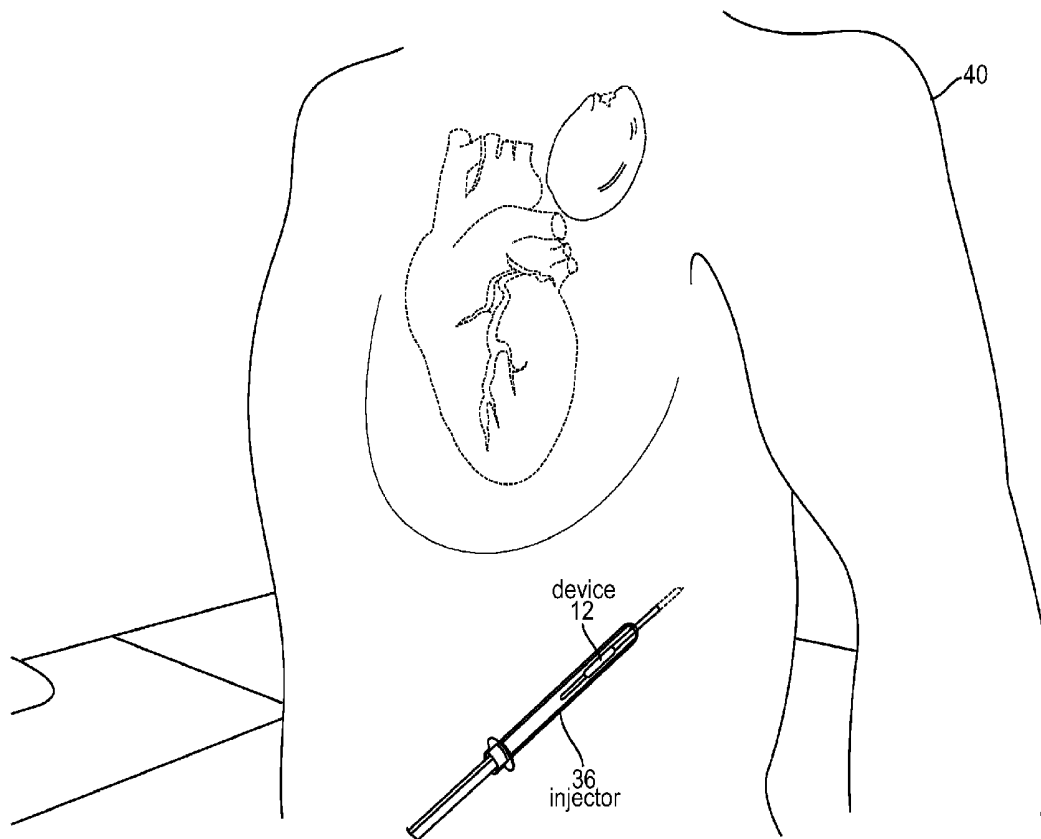

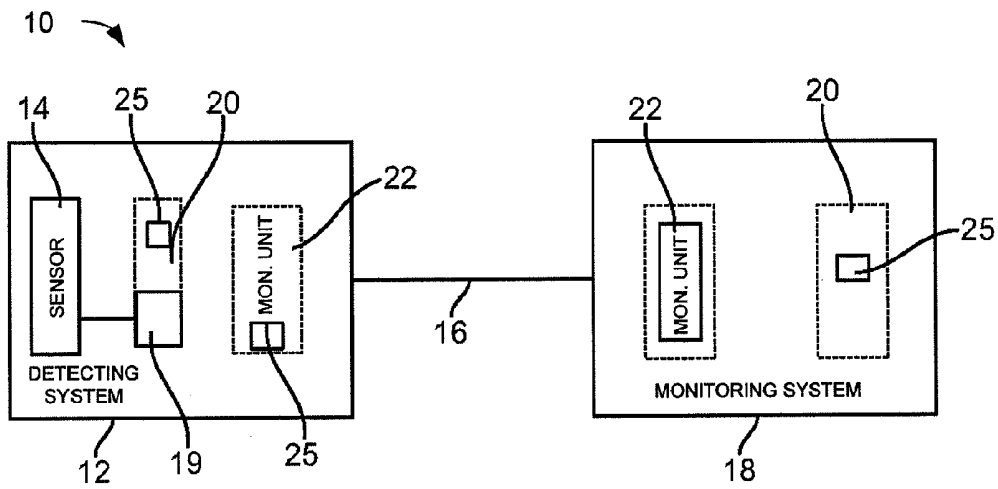

FIG. 1

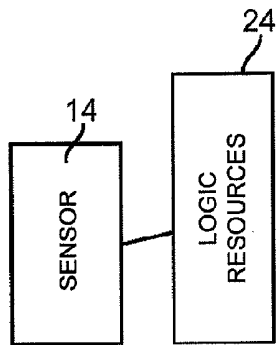

FIG. 4

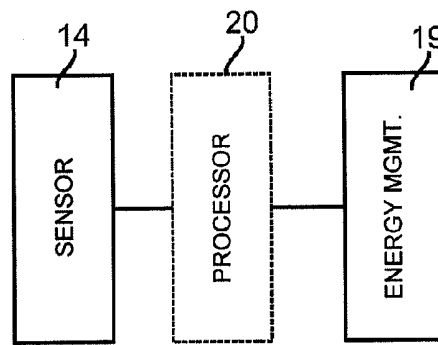

FIG. 3

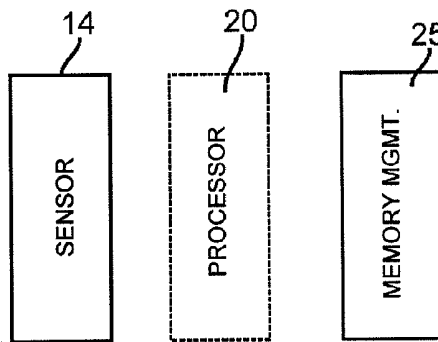

FIG. 5

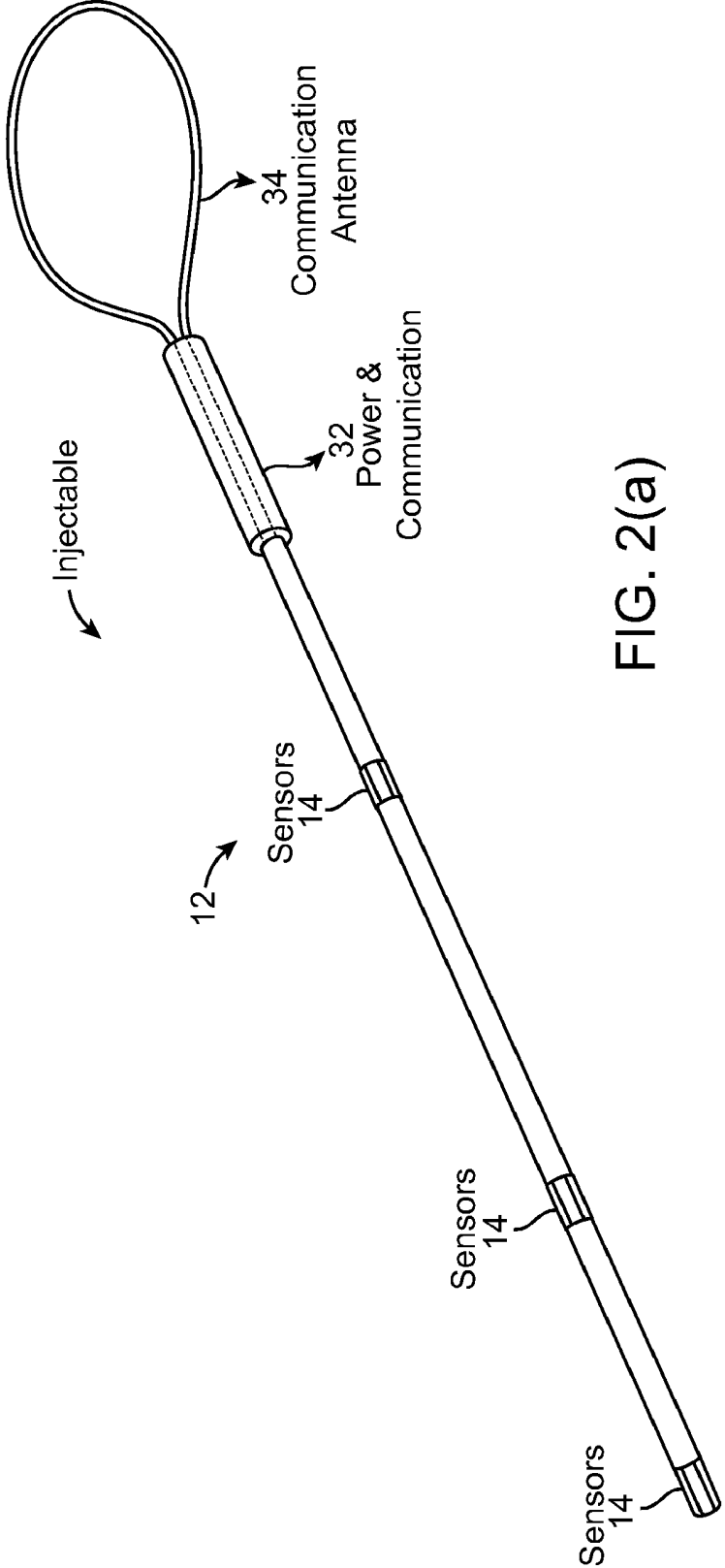

FIG. 2(a)

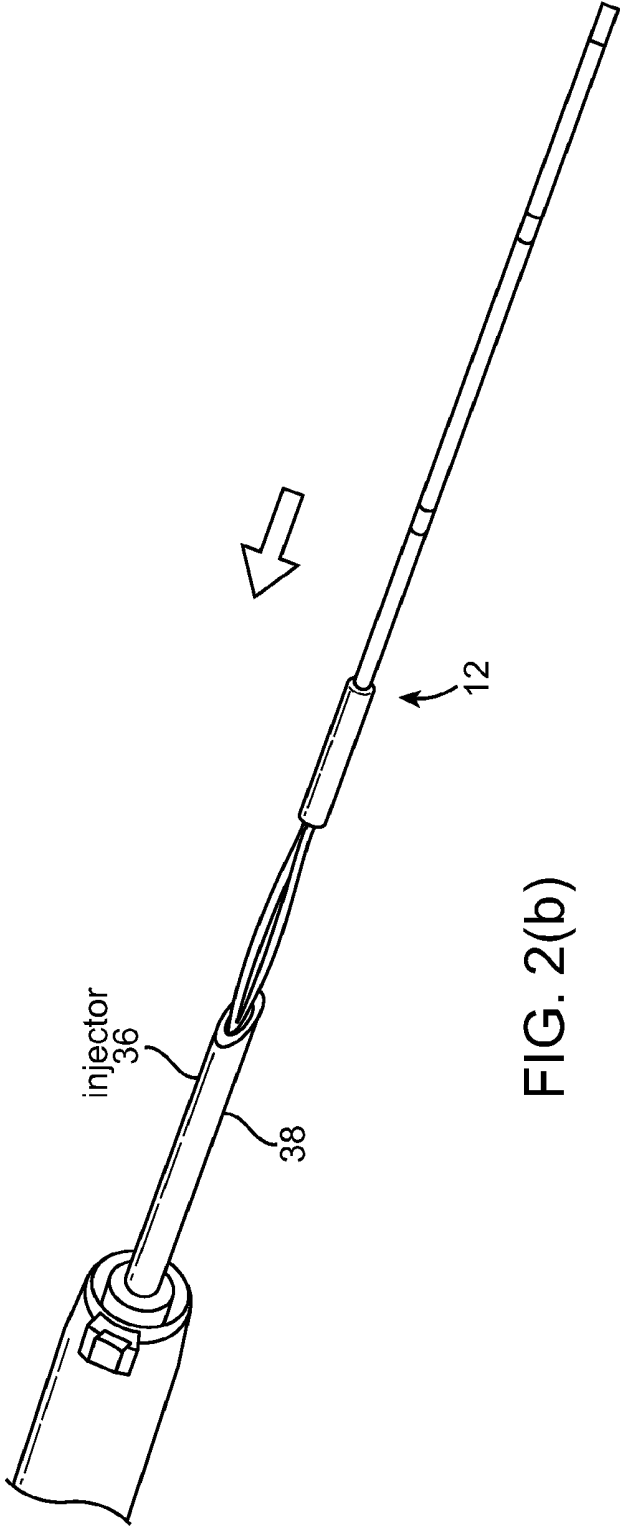

FIG. 2(b)

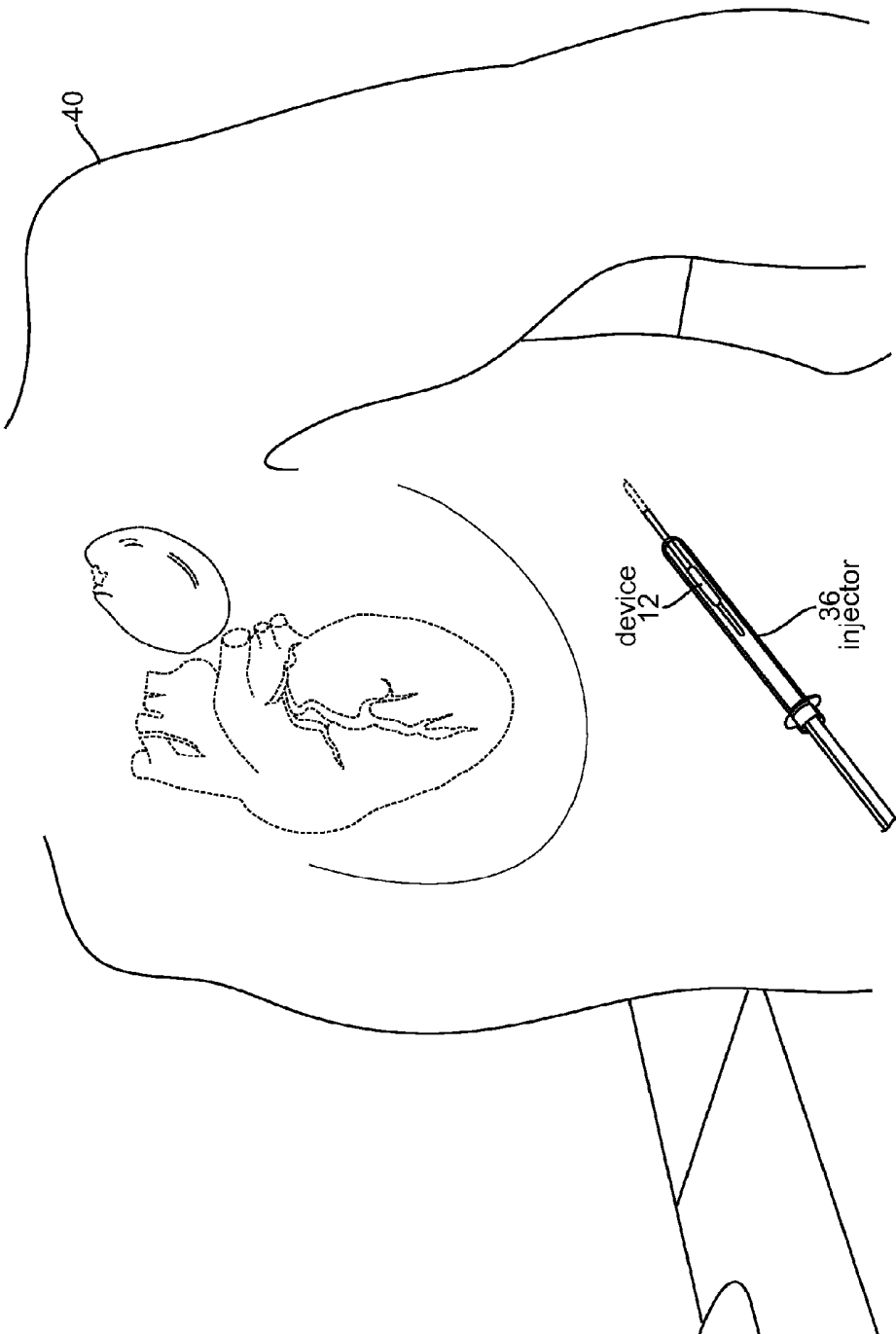

FIG. 2(c)

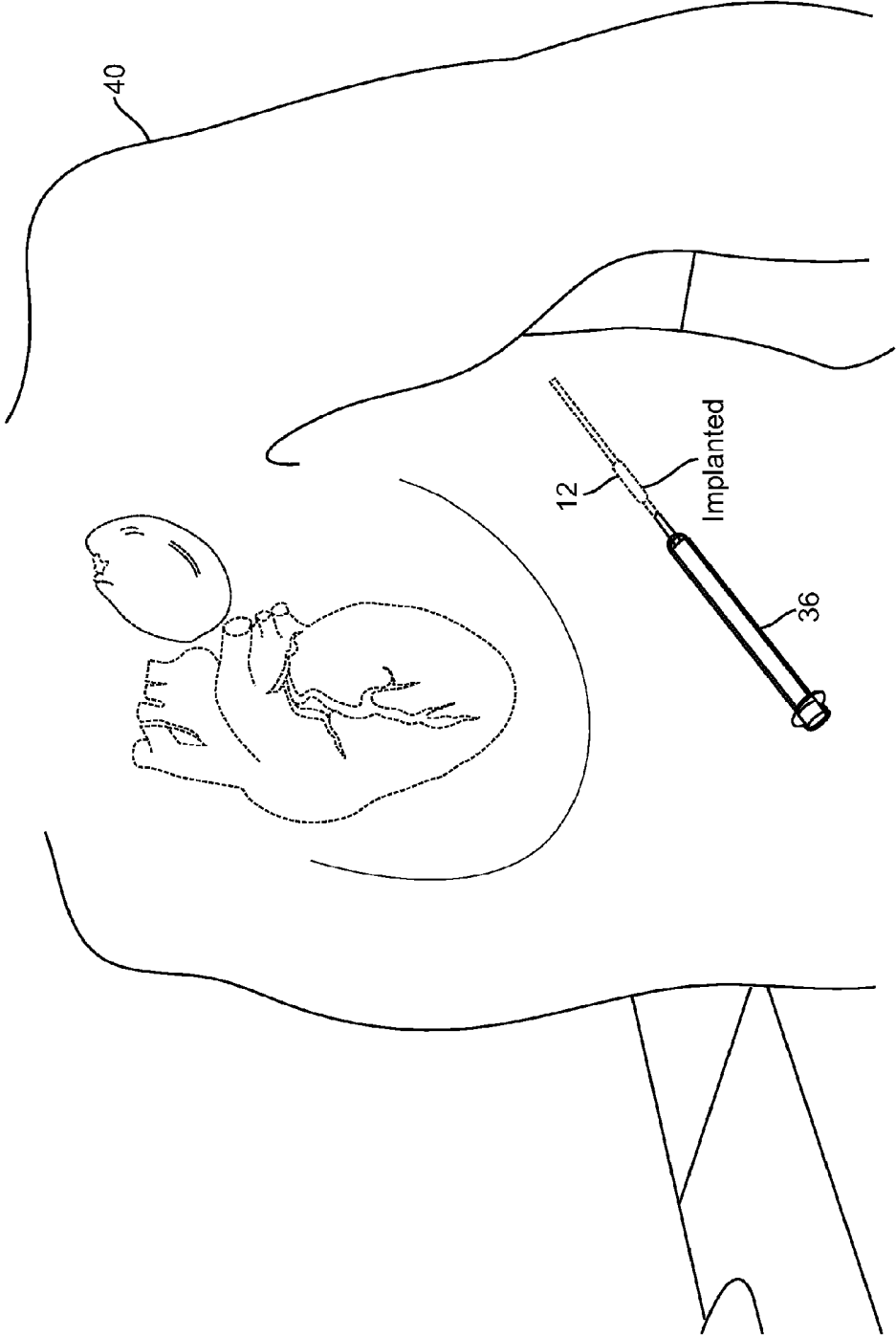

FIG. 2(d)

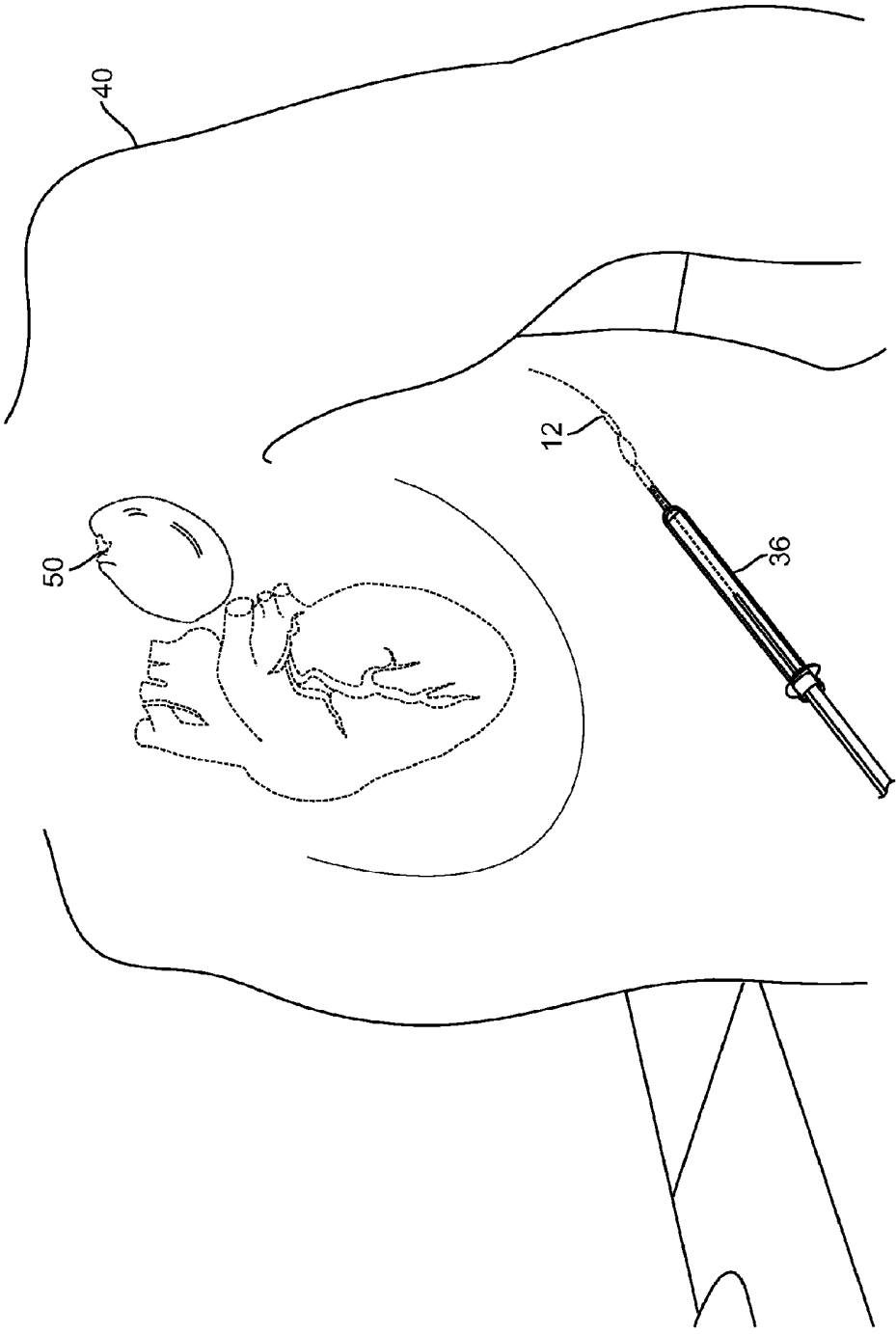

FIG. 2(e)

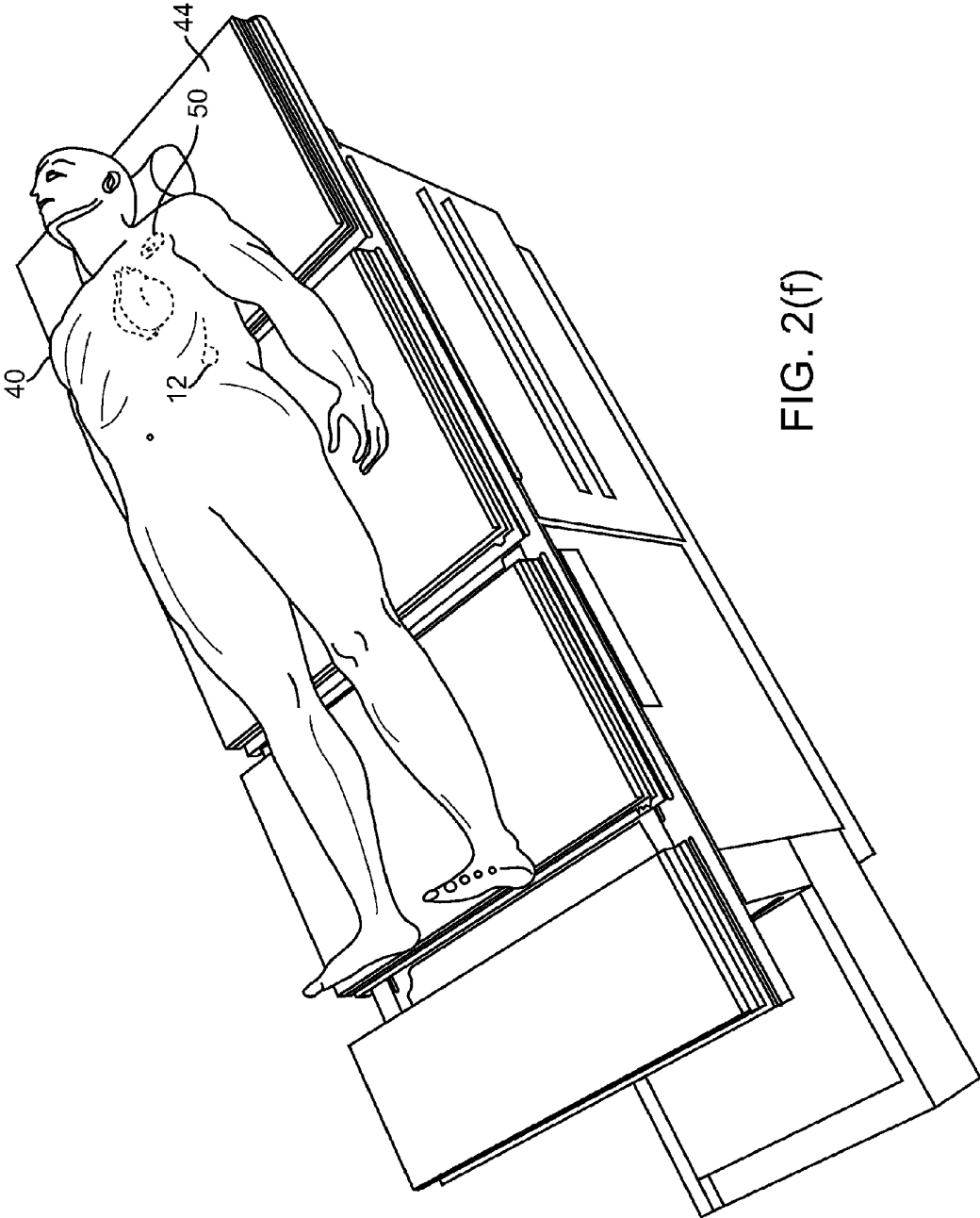

FIG. 2(f)

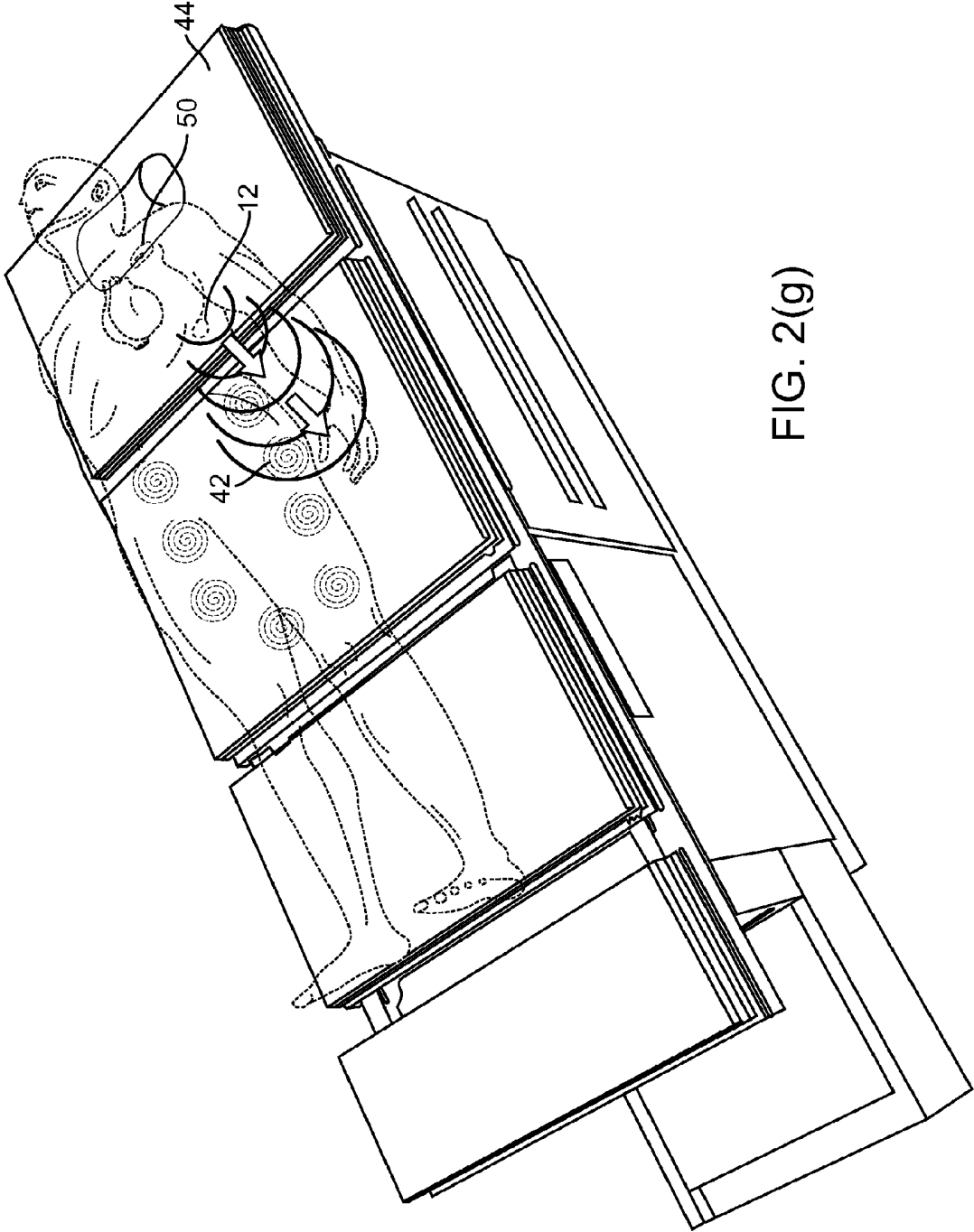

FIG. 2(g)

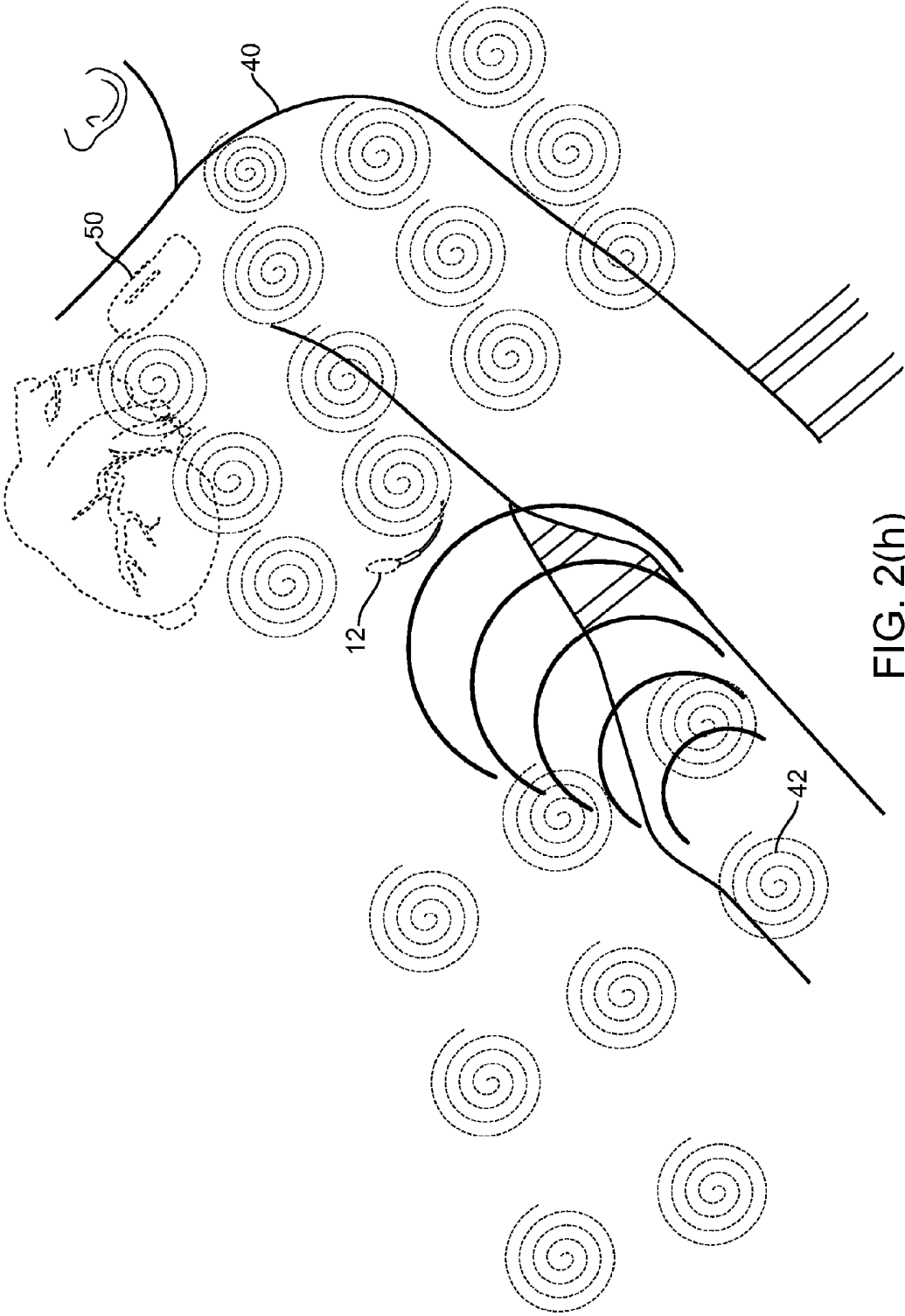

FIG. 2(h)

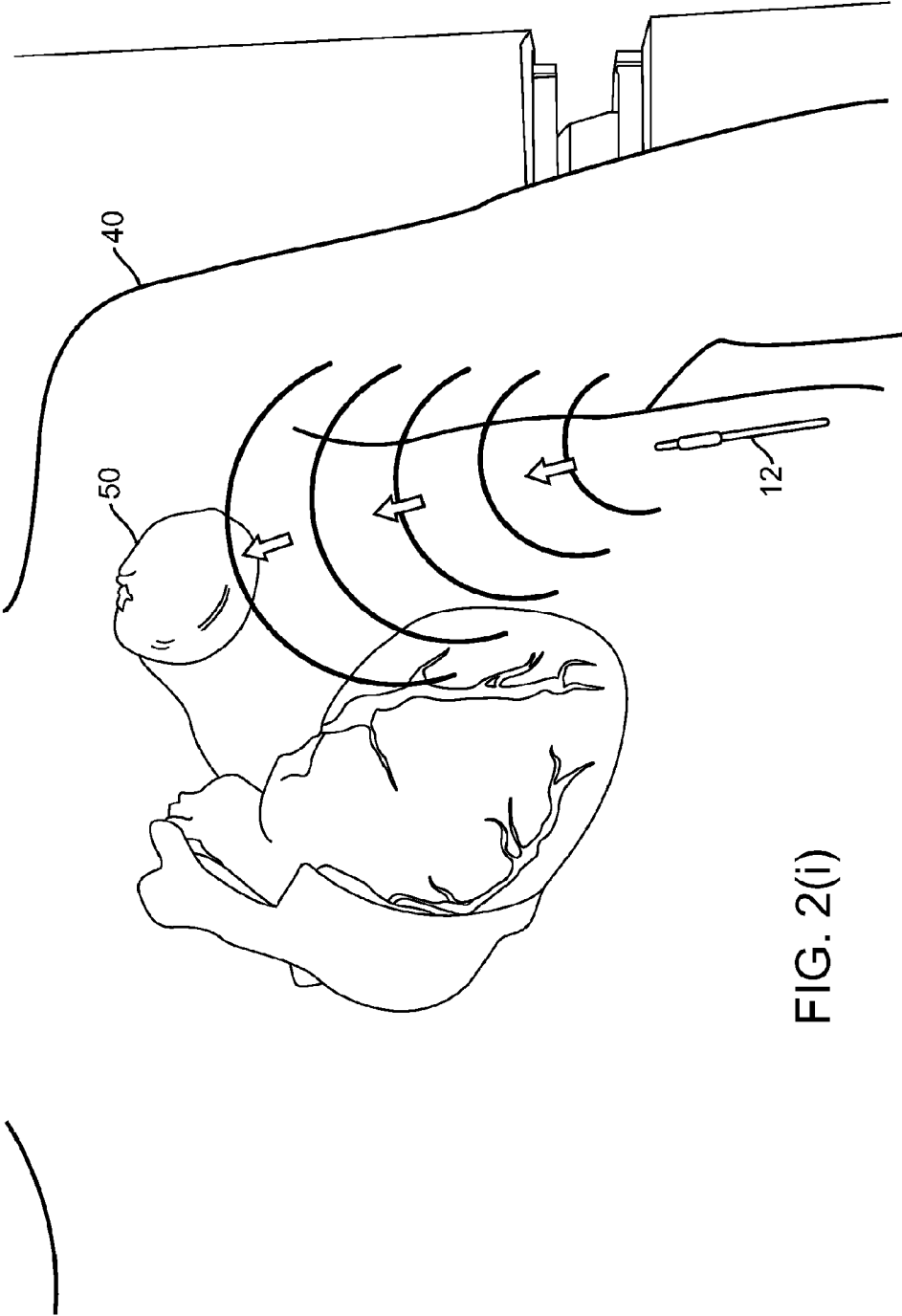

FIG. 2(i)

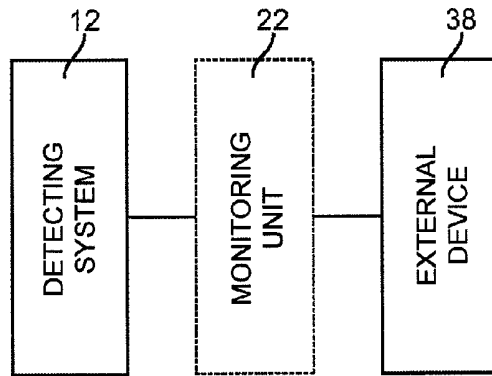

FIG. 6

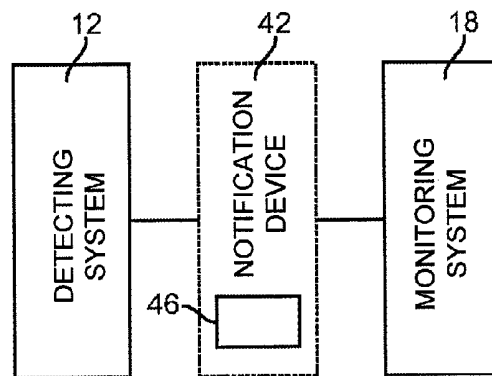

FIG. 7

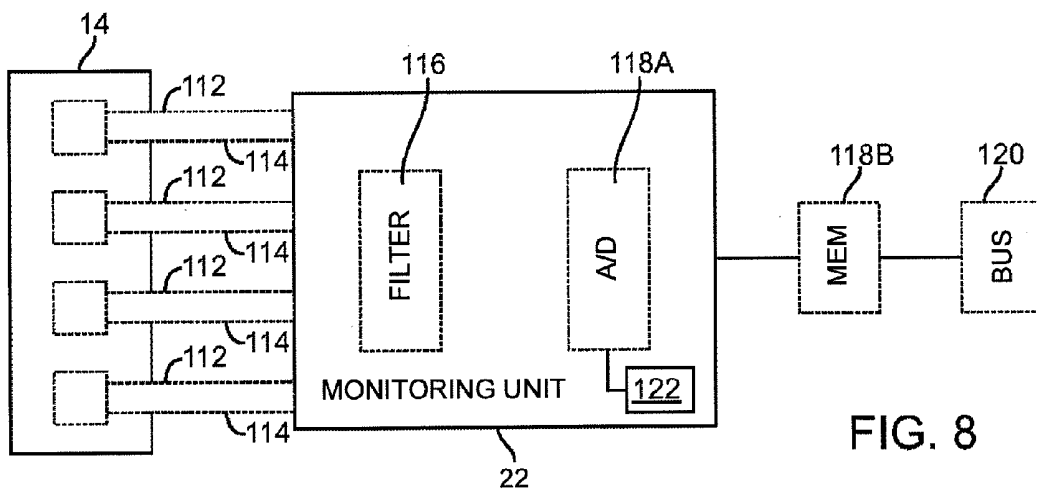

FIG. 8

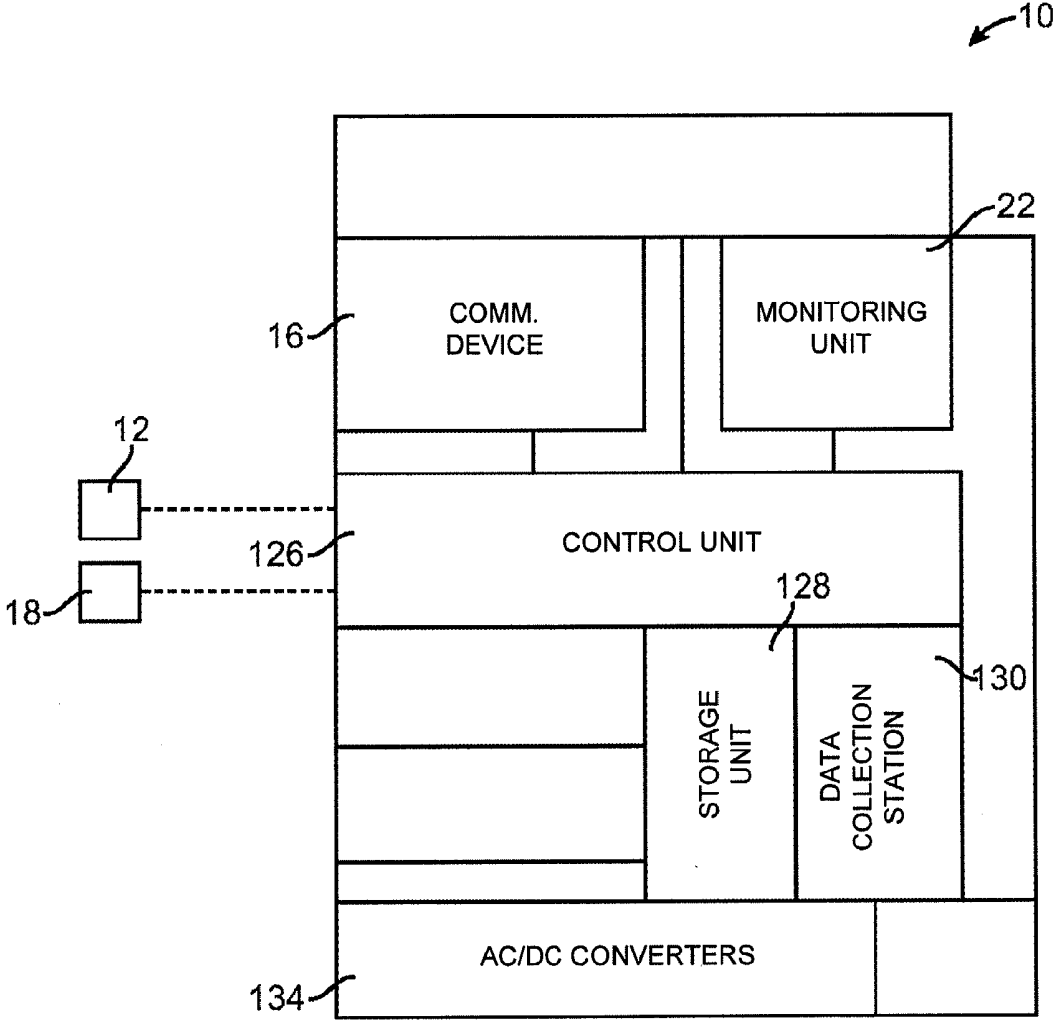

FIG. 9

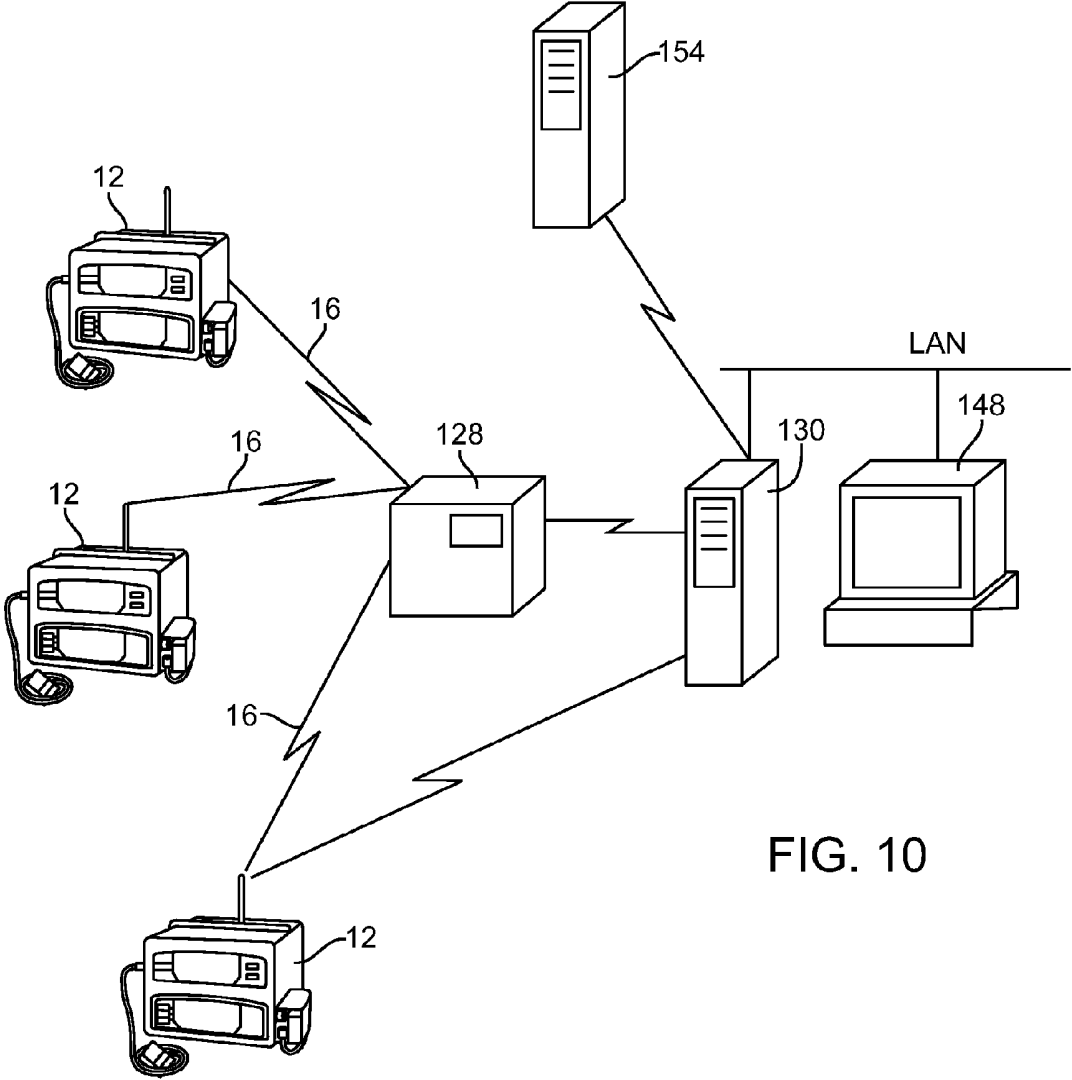

FIG. 10

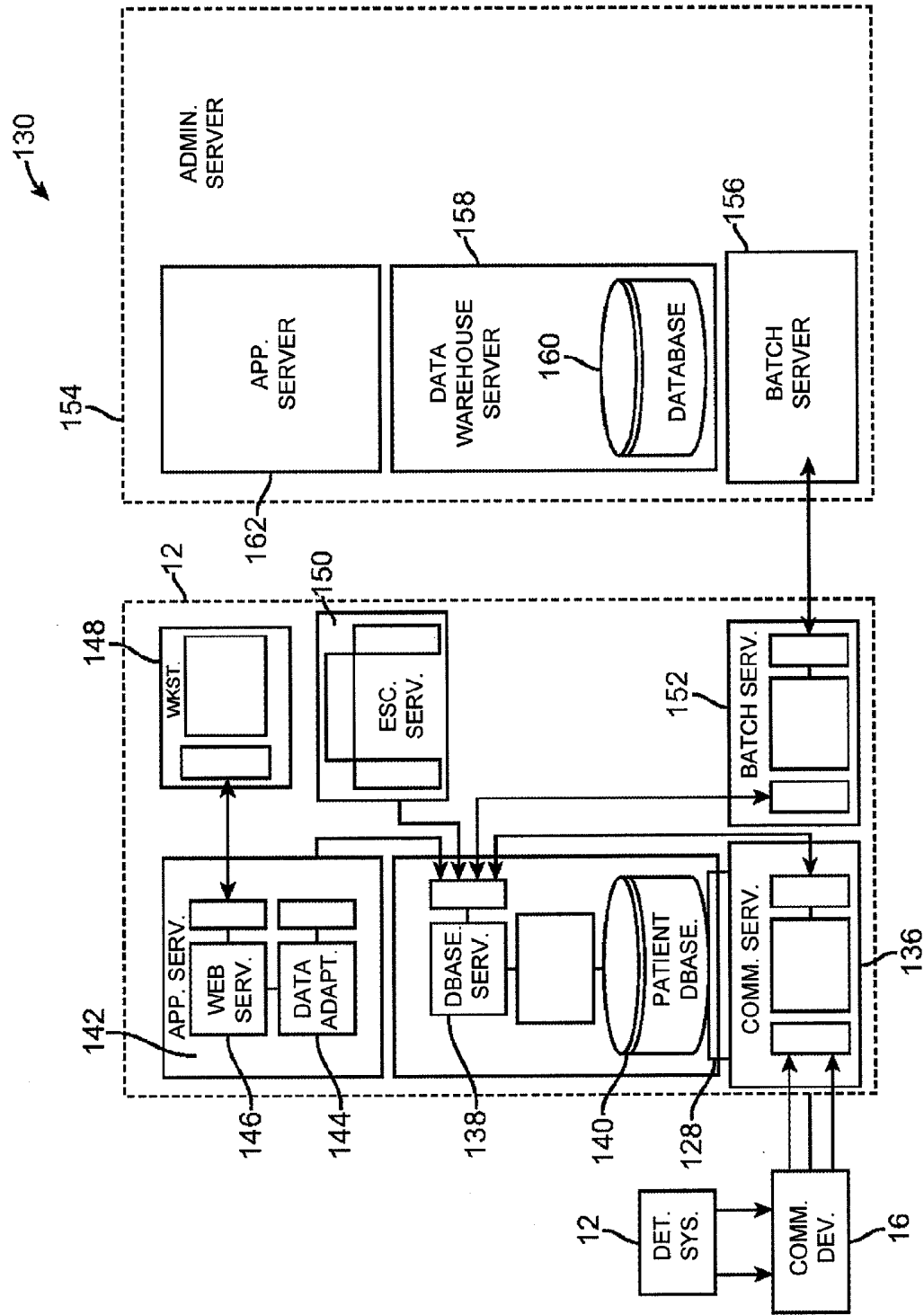

FIG. 11

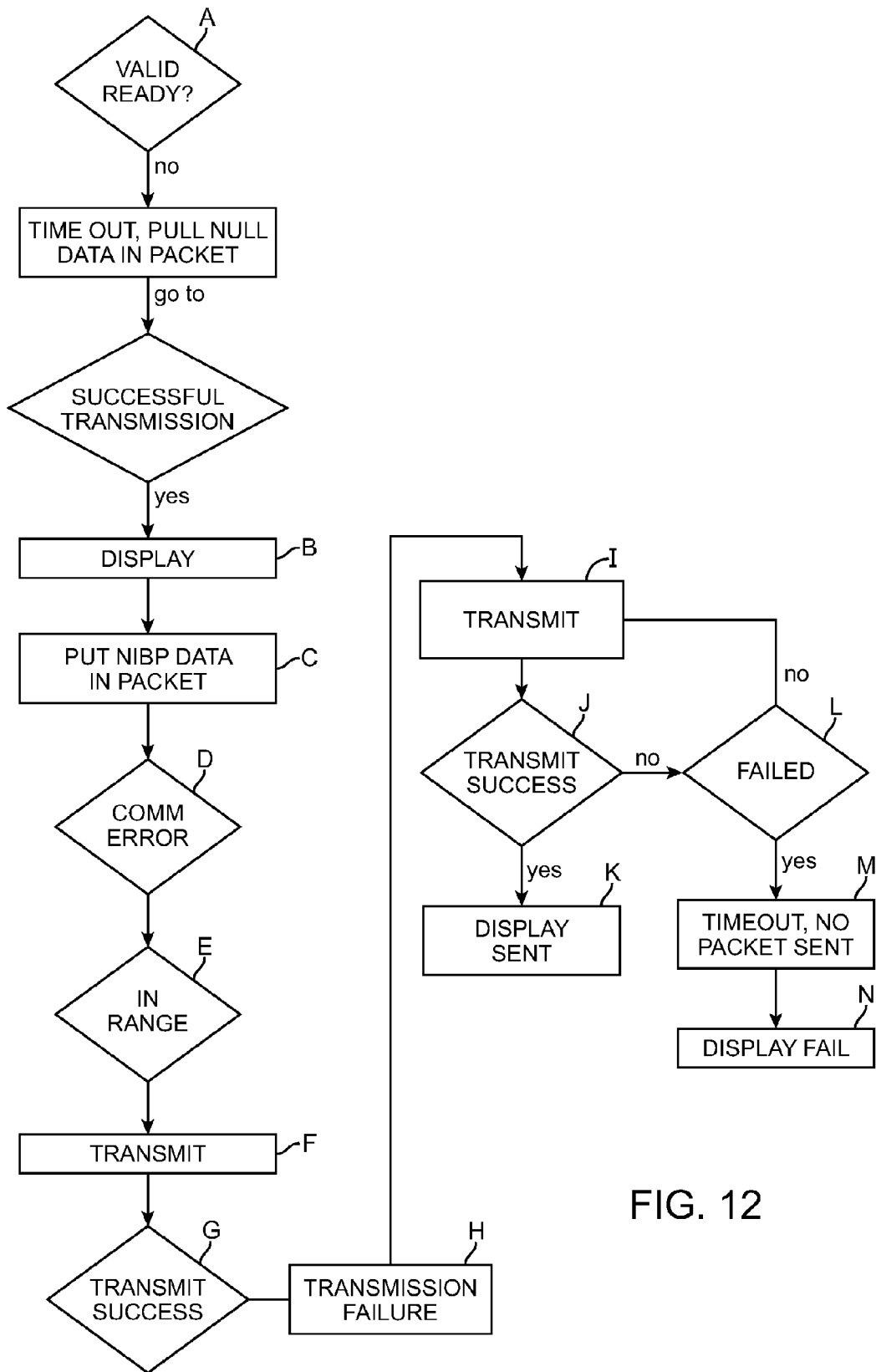

FIG. 12

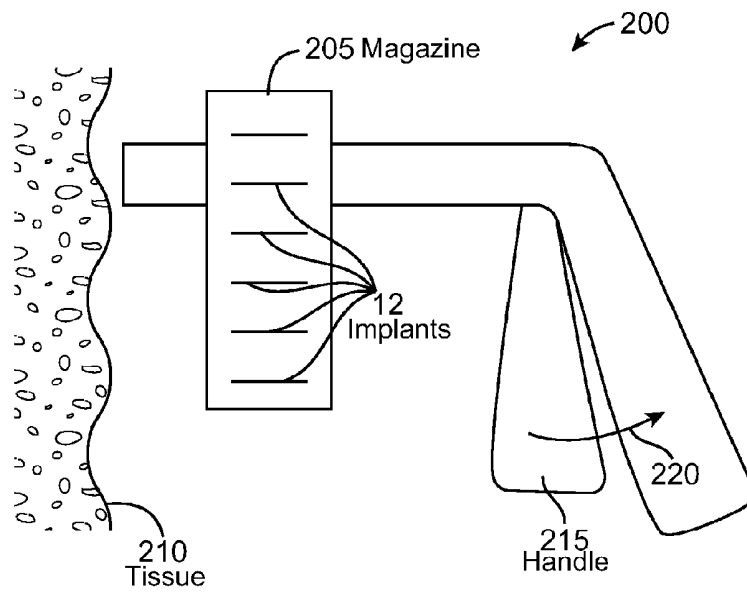

FIG. 13

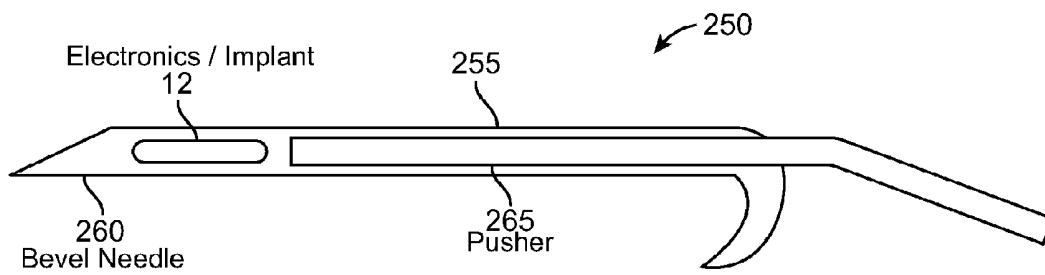

FIG. 14

## INJECTABLE PHYSIOLOGICAL MONITORING SYSTEM

### CROSS-REFERENCES TO RELATED APPLICATIONS

**[0001]** The present application claims the benefit under 35 USC 119(e) of U.S. Provisional Application Nos. 60/972,329, 60/972,336, 60/972,354 and 60/972,537, all filed Sep. 14, 2007, and 61/055,666 filed May 23, 2008; the full disclosures of which are incorporated herein by reference in their entirety.

**[0002]** The subject matter of the present application is related to the following applications: 60/972,512; 60/972,616; 60/972,363; 60/972,343; 60/972,581; 60/972,629; 60/972,316; 60/972,333; 60/972,359; 60/972,336; 60/972,340 all of which were filed on Sep. 14, 2007; 61/046,196 filed Apr. 18, 2008; 61/047,875 filed Apr. 25, 2008; 61/055,645, 61/055,656, 61/055,662, all filed May 23, 2008; and 61/079,746 filed Jul. 10, 2008.

**[0003]** The following applications are being filed concurrently with the present application, on Sep. 12, 2008: Attorney Docket Nos. 026843-000110US entitled "Multi-Sensor Patient Monitor to Detect Impending Cardiac Decompensation Prediction"; 026843-000220US entitled "Adherent Device with Multiple Physiological Sensors"; 026843-000410US entitled "Injectable Device for Physiological Monitoring"; 026843-000620US entitled "Adherent Device for Cardiac Rhythm Management"; 026843-000710US entitled "Adherent Device for Respiratory Monitoring"; 026843-000810US entitled "Adherent Athletic Monitor"; 026843-000910US entitled "Adherent Emergency Monitor"; 026843-001320US entitled "Adherent Device with Physiological Sensors"; 026843-001410US entitled "Medical Device Automatic Start-up upon Contact to Patient Tissue"; 026843-001900US entitled "System and Methods for Wireless Body Fluid Monitoring"; 026843-002010US entitled "Adherent Cardiac Monitor with Advanced Sensing Capabilities"; 026843-002410US entitled "Adherent Device for Sleep Disordered Breathing"; 026843-002710US entitled "Dynamic Pairing of Patients to Data Collection Gateways"; 026843-003010US entitled "Adherent Multi-Sensor Device with Implantable Device Communications Capabilities"; 026843-003110US entitled "Data Collection in a Multi-Sensor Patient Monitor"; 026843-003210US entitled "Adherent Multi-Sensor Device with Empathic Monitoring"; 026843-003310US entitled "Energy Management for Adherent Patient Monitor"; and 026843-003410US entitled "Tracking and Security for Adherent Patient Monitor."

### BACKGROUND OF THE INVENTION

**[0004]** 1. Field of the Invention

**[0005]** This invention relates generally to systems and methods for remote patient monitoring, and more particularly to an injectable physiological monitoring system for decompensation prediction of a heart failure patient.

**[0006]** Frequent monitoring of patients permits the patients' physician to detect worsening symptoms as they begin to occur, rather than waiting until a critical condition has been reached. As such, home monitoring of patients with chronic conditions is becoming increasingly popular in the health care industry for the array of benefits it has the potential to provide. Potential benefits of home monitoring are numerous and include: better tracking and management of

chronic disease conditions, earlier detection of changes in the patient condition, and reduction of overall health care expenses associated with long term disease management. The home monitoring of a number of diverse "chronic diseases" is of interest, where such diseases include diabetes, dietary disorders such as anorexia and obesity, anxiety, depression, epilepsy respiratory diseases, AIDS and other chronic viral conditions, conditions associated with the long term use of immunosuppressant's, e.g. in transplant patients, asthma, chronic hypertension, chronic use of anticoagulants, and the like.

**[0007]** Of particular interest in the home monitoring sector of the health care industry is the remote monitoring of patients with heart failure (HF), also known as congestive heart failure. HF is a syndrome in which the heart is unable to efficiently pump blood to the vital organs. Most instances of HF occur because of a decreased myocardial capacity to contract (systolic dysfunction). However, HF can also result when an increased pressure-stroke-volume load is imposed on the heart, such as when the heart is unable to expand sufficiently during diastole to accommodate the ventricular volume, causing an increased pressure load (diastolic dysfunction).

**[0008]** In either case, HF is characterized by diminished cardiac output and/or damming back of blood in the venous system. In HF, there is a shift in the cardiac function curve and an increase in blood volume caused in part by fluid retention by the kidneys. Indeed, many of the significant morphologic changes encountered in HF are distant from the heart and are produced by the hypoxic and congestive effects of the failing circulation upon other organs and tissues. One of the major symptoms of HF is edema, which has been defined as the excessive accumulation of interstitial fluid, either localized or generalized.

**[0009]** HF is the most common indication for hospitalization among adults over 65 years of age, and the rate of admission for this condition has increased progressively over the past two decades. It has been estimated that HF affects more than 3 million patients in the U.S. (O'Connell, J. B. et al., *J. Heart Lung Transpl.*, 13(4):S107-112 (1993)).

**[0010]** In the conventional management of HF patients, where help is sought only in crisis, a cycle occurs where patients fail to recognize early symptoms and do not seek timely help from their care-givers, leading to emergency department admissions (Miller, P. Z., *Home monitoring for congestive heart failure patients*, Caring Magazine, 53-54 (August 1995)).

**[0011]** Recently, a prospective, randomized trial of 282 patients was conducted to assess the effect of the intervention on the rate of admission, quality of life, and cost of medical care. In this study, a nurse-directed, multi-disciplinary intervention (which consisted of comprehensive education of the patient and family, diet, social-service consultation and planning, review of medications, and intensive assessment of patient condition and follow-up) resulted in fewer readmissions than the conventional treatment group and a concomitant overall decrease in the cost of care (Rich, M. W. et al., *New Engl. J. Med.*, 333:1190-95 (1995)).

**[0012]** Similarly, comprehensive discharge planning and a home follow-up program was shown to decrease the number of readmissions and total hospital charges in an elderly population (Naylor, M. et al., *Amer. College Physicians*, 120:999-1006 (1994)). Therefore, home monitoring is of particular interest in the HF management segment of the health care industry.

**[0013]** Another area in which home-monitoring is of particular interest is in the remote monitoring of a patient parameter that provides information on the titration of a drug, particularly with drugs that have a consequential effect following administration, such as insulin, anticoagulants, ACE inhibitors, beta-blockers, diuretics and the like.

**[0014]** Although a number of different home monitoring systems have been developed, there is continued interest in the development of new monitoring systems. Of particular interest would be the development of a system that provides for improved patient compliance, ease of use, etc. Of more particular interest would be the development of such a system that is particularly suited for use in the remote monitoring of patients suffering from HF.

**[0015]** Subcutaneous implantation of sensors has been achieved with an insertion and tunneling tool. The tunneling tool includes a stylet and a peel-away sheath. The tunneling tool is inserted into an incision and the stylet is withdrawn once the tunneling tool reaches a desired position. An electrode segment is inserted into the subcutaneous tunnel and the peel-away sheath is removed. In another delivery device, a pointed tip is inserted through the skin and a plunger is actuated to drive the sensor to its desired location.

**[0016]** In other delivery systems, an implant trocar includes a cannula for puncturing the skin and an obturator for delivering the implant. A spring element received within the cannula prevents the sensor from falling out during the implant process. Another sensor delivery device includes an injector that has a tubular body divided into two adjacent segments with a hollow interior bore. A pair of laterally adjacent tines extend longitudinally from the first segment to the distal end of the tubular body. A plunger rod has an exterior diameter just slightly larger than the interior diameter of the tubular body. With the second segment inserted beneath the skin, the push rod is advanced longitudinally through the tubular body, thereby pushing the sensor through the bore. As the implant and rod pass through the second segment, the tines are forced radially away from each other, thereby dilating or expanding the incision, and facilitating implant. The instrument is removed from the incision following implantation.

**[0017]** For the above and other reasons, it would be desirable to provide a non-surgical instrument and method for subcutaneous implantation of sensors and solid materials that preferably does not require an incision preparatory to instrument insertion. It would also be desirable to provide an improved home monitoring of patients with chronic conditions and improved percutaneous sensor delivery devices.

#### BRIEF SUMMARY OF THE INVENTION

**[0018]** In a first aspect, embodiments of the present invention provide a system for decompensation prediction of a heart failure patient. The system comprises one or more injectable detecting systems having a plurality of sensors that provide an indication of at least one physiological event of a patient, a wireless communication device coupled to the one or more injectable detecting systems and configured to transfer patient data directly or indirectly from the one or more injectable detecting systems to a remote monitoring system, and a remote monitoring system coupled to the wireless communication device, the remote monitoring system using processed data to determine heart failure status and predict impending decompensation of the patient.

**[0019]** In another aspect, embodiments of the present invention provide a system for decompensation prediction of

a heart failure patient. The system comprises one or more injectable detecting systems having a plurality of sensors that provide an indication of at least one physiological event of a patient, the one or more injectable detecting systems being inserted below the skin of the patient, the one or more injectable detecting systems being injected below the skin of the patient by gun or syringe injection, a wireless communication device coupled to the one or more injectable detecting systems and configured to transfer patient data directly or indirectly from the one or more injectable detecting systems to a remote monitoring system, and a remote monitoring system coupled to the wireless communication device, the remote monitoring system using processed data to determine heart failure status and predict impending decompensation of the patient.

**[0020]** In another aspect, embodiments of the present invention provide a method for decompensation prediction of a heart failure patient. The method comprising injecting subcutaneously one or more injectable detecting systems having a plurality of sensors that provide an indication of at least one physiological event of a patient, wirelessly transferring patient data directly or indirectly from the one or more injectable detecting systems to a remote monitoring system via a wireless communication device coupled to the one or more injectable detecting systems, and processing the data using the remote monitoring system to determine heart failure status and predict impending decompensation of the patient.

**[0021]** In many embodiments, the one or more injectable detecting systems are inserted below the skin of the patient by at least one of, catheter delivery, blunt tunneling and needle insertion.

**[0022]** In many embodiments, the systems and methods further comprise an imaging system to assist in guiding the injectable detecting system to a desired location.

**[0023]** In many embodiments, each of a sensor is selected from at least one of, bioimpedance, heart rate, heart rhythm, HRV, HRT, heart sounds, respiratory sounds, respiratory rate and respiratory rate variability, blood pressure, activity, posture, wake/sleep, orthopnea, temperature, heat flux and an accelerometer.

**[0024]** In many embodiments, each of a sensor is an activity sensors selected from at least one of, ball switch, accelerometer, minute ventilation, HR, bioimpedance noise, skin temperature/heat flux, BP, muscle noise and posture.

**[0025]** In many embodiments, the injectable detecting systems include a power source, a memory, logic resources and an antenna. In many embodiments the power source is a rechargeable battery transcutaneously with an external unit.

**[0026]** In many embodiments, at least a portion of the injectable detecting systems have a drug eluting coating.

**[0027]** In many embodiments, the one or more injectable detecting systems are anchored in the patient by at least one of, barbs, anchors, tissue adhesion pads, suture loops, shape of device, self-expanding metal structure, wherein self-expanding metal structure is made of Nitinol.

**[0028]** In another aspect, embodiments of the present invention provide an injection system for injecting one or more injectable physiological monitoring systems for use in physiological monitoring of a patient. The system includes a body capable of holding one or more injectable physiological monitoring systems, the body having a proximal end and distal end, wherein the distal end is shaped to penetrate tissue, a pusher configured to engage the one or more injectable physiological monitoring systems within the body and a mov-

able handle coupled to a pusher configured to distally advance the one or more injectable physiological monitoring systems through the body.

#### BRIEF DESCRIPTION OF THE DRAWINGS

[0029] FIG. 1 is a block diagram illustrating one embodiment of a patient monitoring system of the present invention.

[0030] FIG. 2(a) illustrates one embodiment of an injectable detecting system of the present invention that is injectable and includes multiple sensors, power and communication and a communication antenna.

[0031] FIG. 2(b) illustrates the insertion of the device of FIG. 2(a) into an injector.

[0032] FIG. 2(c) illustrates the device of FIG. 2(a) in the injector and ready to be introduced into the patient.

[0033] FIG. 2(d) illustrates the implanted sensor device of FIG. 2(a).

[0034] FIG. 2(e) illustrates the implanted sensor device of FIG. 2(a) as it flexes from a rigid state in the body.

[0035] FIG. 2(f) illustrates a patient laying on top of a matt that has coils, where downloading of patient data and recharging can occur via the matt or also through an adherent patch or wearable device by the patient.

[0036] FIG. 2(g) illustrates the patient laying on top of the matt from FIG. 2(f) and the downloading of data from the sensors to the matt.

[0037] FIG. 2(h) is a close up view of FIG. 2(g) showing the downloading of data from the sensors to the matt, and then transfer of the data from the matt to a modem.

[0038] FIG. 2(i) illustrates a patient with an implanted device, such as a pacing device, and the implanted device of FIG. 2(a) in communication with the implanted device.

[0039] FIG. 3 illustrates one embodiment of an energy management device that is coupled to the plurality of sensors of FIG. 1.

[0040] FIG. 4 illustrates one embodiment of present invention illustrating logic resources configured to receive data from the sensors and/or the processed patient for monitoring purposes, analysis and/or prediction purposes.

[0041] FIG. 5 illustrates an embodiment of the patient monitoring system of the present invention with a memory management device.

[0042] FIG. 6 illustrates an embodiment of the patient monitoring system of the present invention with an external device coupled to the sensors.

[0043] FIG. 7 illustrates an embodiment of the patient monitoring system of the present invention with a notification device.

[0044] FIG. 8 is a block diagram illustrating an embodiment of the present invention with sensor leads that convey signals from the sensors to a monitoring unit at the detecting system, or through a wireless communication device to a remote monitoring system.

[0045] FIG. 9 is a block diagram illustrating an embodiment of the present invention with a control unit at the detecting system and/or the remote monitoring system.

[0046] FIG. 10 is a block diagram illustrating an embodiment of the present invention where a control unit encodes patient data and transmits it to a wireless network storage unit at the remote monitoring system.

[0047] FIG. 11 is a block diagram illustrating one embodiment of an internal structure of a main data collection station at the remote monitoring system of the present invention.

[0048] FIG. 12 is a flow chart illustrating an embodiment of the present invention with operation steps performed by the system of the present invention in transmitting information to the main data collection station.

[0049] FIG. 13 shows one embodiment of an injection system for use with multiple injectable detecting systems.

[0050] FIG. 14 shows one embodiment of an injection system that includes a bevel needle shaped to receive the injectable detecting system.

#### DETAILED DESCRIPTION OF THE INVENTION

[0051] The present invention is directed to a heart failure patient management system consisting of one or more subcutaneously injectable physiological monitoring systems inserted below the patient's skin. The system continuously monitors physiological parameters, communicates wirelessly with a remote center, and provides alerts when necessary. A variety of delivery devices and methods are also disclosed.

[0052] The system monitors physiological parameters and uses a proprietary algorithm to determine heart failure status and predict impending decompensation. The injectable system communicates with a remote center, preferably via an intermediate device in the patient's home. In some embodiments, the remote center receives the data and applies the prediction algorithm. When a flag is raised, the center may communicate with the patient, hospital, nurse, and/or physician to allow for therapeutic intervention to prevent decompensation.

[0053] The injectable system may be inserted with one of the following techniques: catheter delivery, blunt tunneling (with either a separate tunneling tool or a wire-stiffened lead), and insertion with a needle. The injectable system may be injected with a gun or syringe-like device. The injectable system may be flexible, and may be implanted with a stiffening wire or stylet.

[0054] The injectable system may be implanted in a non-sterile, non-surgical setting. Implantation may occur with or without local anesthesia, and with or without imaging assistance.

[0055] The system may consist of an implantable component and an external component. In such an embodiment, the injected component, with or without physiological sensing electrodes, would be used to anchor an external electronics unit. The anchoring mechanism may be magnetic or mechanical.

[0056] The injectable system may contain one of the following features to facilitate subsequent extraction: an isodiametric profile, a breakaway anchor, a bioabsorbable material, coatings to limit tissue in-growth, and an electrically activated or fusible anchor. The injectable system may be modular, containing multiple connected components, a subset of which is easily extractable.

[0057] While the present invention is intended for heart failure patient monitoring, the system may be applicable to any human application in which wireless physiological monitoring and prediction is required.

[0058] In one embodiment, illustrated in FIG. 1, the present invention is a system that delivers a percutaneous sensing device for remote patient monitoring. The remote monitoring tracks the patient's physiological status, detects and predicts negative physiological events. In one embodiment, the implanted sensing device includes a plurality of sensors that

are used in combination to enhance detection and prediction capabilities as more fully explained below.

[0059] Referring again to FIG. 1, in one embodiment, the system 10 includes an injectable detecting system 12 that includes a plurality of sensors 14 and/or electrodes, that provide an indication of at least one physiological event of a patient. The injectable detecting system 12 is inserted subcutaneously. In one embodiment the injectable detecting system 12 is inserted in the patient's thorax. The system 10 also includes a wireless communication device 16, coupled to the plurality of sensors 14. The wireless communication device transfers patient data directly or indirectly from the plurality of sensors 14 to a remote monitoring system 18. The remote monitoring system 18 uses data from the sensors to determine the patient's status. The system 10 can continuously, or non-continuously, monitor the patient, alerts are provided as necessary and medical intervention is provided when required. In one embodiment, the wireless communication device 16 is a wireless local area network for receiving data from the plurality of sensors.

[0060] The sensors 14 are subcutaneously inserted with the injectable detecting system 12 that is catheter based, blunt tunneling (with either a separate tunneling tool or a wire-stiffened lead), needle insertion gun or syringe-like injection. The injectable detecting system 12 can be flexible, and be used with a stiffening wire, stylet, catheter or guidewire. The injectable detecting system 12 can include any of the following to assist in subsequent extraction: (i) an isodiametric profile, (ii) a breakaway anchor, (iii) a bioabsorbable material, (iv) coatings to limit tissue in-growth, (v) an electrically activated or fusible anchor, and the like. The injectable detecting system 12 can be modular, containing multiple connected components, a subset of which is easily extractable.

[0061] The injectable detecting system 12 can be inserted in the patient in a non-sterile or sterile setting, non-surgical setting or surgical setting, implanted with or without anesthesia and implanted with or without imaging assistance from an imaging system. The injectable detecting system 12 can be anchored in the patient by a variety of means including but not limited to, barbs, anchors, tissue adhesion pads, suture loops, with sensor shapes that conform to adjacent tissue anatomy or provide pressure against the adjacent tissue, with the use of self-expanding materials such as a nitinol anchor and the like.

[0062] FIG. 2(a) shows one embodiment of the injectable detecting system 12 with sensors 14 that is introduced below the skin surface. The device includes power and communication elements 32, and a communication antenna 34. The antenna may be a self expanding antenna expandable from a first compressed shape to a second expanded shape, such as disclosed in U.S. Provisional Application No. 61/084,567, filed Jul. 29, 2008 entitled "Communication-Anchor Loop For Injectable Device", the full disclosure of which is incorporated herein by reference. FIG. 2(b) illustrates the injectable detecting system 12 being loaded into an injector 36 having a needle end 38. FIG. 2(c) shows the injectable detecting system 12 being introduced subcutaneously into a patient 40. FIG. 2(d) shows the injectable detecting system 12 being implanted subcutaneously from the injector 36. In FIG. 2(e), the injector 36 is removed and the injectable detecting system 12 flexes from a rigid configuration.

[0063] In one embodiment, illustrated in FIGS. 2(f) and 2(g), recharging coils 42 are placed in a mat 44 on the patient's bed, such as under a mattress pad. Recharging of the

sensors/battery and data transfer can occur during sleep of the patient. The rechargeable batteries can be transcutaneously charged with an external unit other than the mat. FIG. 2(g) shows downloading from the sensors and data transfer during sleep of the patient. In FIG. 2(h), the injectable detecting system 12 downloads data to the mat and a modem is used from data transfer. In FIG. 2(i), an implantable device 50, such as a pacing device communicates with the injectable detecting system 12 of FIG. 2(a).

[0064] In one embodiment, the wireless communication device 16 is configured to receive instructional data from the remote monitoring system and communicate instructions to the injectable detecting system.

[0065] As illustrated in FIG. 3, an energy management device 19 is coupled to the plurality of sensors. In one embodiment, the energy management device 19 is part of the detecting system. In various embodiments, the energy management device 19 performs one or more of, modulate drive levels per sensed signal of a sensor 14, modulate a clock speed to optimize energy, watch cell voltage drop - unload cell, coulomb-meter or other battery monitor, sensor droppoff at an end of life of a battery coupled to a sensor, battery end of life droppoff to transfer data, elective replacement indicator, call center notification, sensing windows by the sensors 14 based on a monitored physiological parameter and sensing rate control.

[0066] In one embodiment, the energy management device 19 is configured to manage energy by at least one of, a thermo-electric unit, kinetics, fuel cell, nuclear power, a micro-battery and with a rechargeable device.

[0067] The system 10 is configured to automatically detect events. The system 10 automatically detects events by at least one of, high noise states, physiological quietness, sensor continuity and compliance. In response to a detected physiological event, patient states are identified when data collection is inappropriate. In response to a detected physiological event, patient states are identified when data collection is desirable. Patient states include, physiological quietness, rest, relaxation, agitation, movement, lack of movement and a patient's higher level of patient activity.

[0068] The system uses an intelligent combination of sensors to enhance detection and prediction capabilities, as more fully disclosed in U.S. patent application Ser. Nos. 60/972,537 filed Sep. 14, 2008 and 61/055,666 filed May 23, 2008, both titled "Adherent Device with Multiple Physiological Sensors", incorporated herein by reference, and as more fully explained below.

[0069] In one embodiment, the injectable detecting system 12 communicates with the remote monitoring system 18 periodically or in response to a trigger event. The trigger event can include but is not limited to at least one of, time of day, if a memory is full, if an action is patient initiated, if an action is initiated from the remote monitoring system, a diagnostic event of the monitoring system, an alarm trigger, a mechanical trigger, and the like.

[0070] The injectable detecting system 12 can continuously, or non-continuously, monitor the patient, alerts are provided as necessary and medical intervention is provided when required. In one embodiment, the wireless communication device 16 is a wireless local area network for receiving data from the plurality of sensors in the injectable detecting system.

[0071] A processor 20 is coupled to the plurality of sensors 14 in the injectable detecting system 12. The processor 20

receives data from the plurality of sensors **14** and creates processed patient data. In one embodiment, the processor **20** is at the remote monitoring system **18**. In another embodiment, the processor **20** is at the detecting system **12**. The processor **20** can be integral with a monitoring unit **22** that is part of the injectable detecting system **12** or part of the remote monitoring system **18**.

[0072] The processor **20** has program instructions for evaluating values received from the sensors **14** with respect to acceptable physiological ranges for each value received by the processor **20** and determine variances. The processor **20** can receive and store a sensed measured parameter from the sensors **14**, compare the sensed measured value with a predetermined target value, determine a variance, accept and store a new predetermined target value and also store a series of questions from the remote monitoring system **18**.

[0073] As illustrated in FIG. 4, logic resources **24** are provided that take the data from the sensors **14**, and/or the processed patient data from the processor **20**, to predict an impending decompensation. The logic resources **24** can be at the remote monitoring system **18** or at the detecting system **12**, such as in the monitoring unit **22**.

[0074] In one embodiment, a memory management device **25** is provided as illustrated in FIG. 5. In various embodiments, the memory management device **25** performs one or more of data compression, prioritizing of sensing by a sensor **14**, monitoring all or some of sensor data by all or a portion of the sensors **14**, sensing by the sensors **14** in real time, noise blanking to provide that sensor data is not stored if a selected noise level is determined, low-power of battery caching and decimation of old sensor data.

[0075] The injectable detecting system **12** can provide a variety of different functions, including but not limited to, initiation, programming, measuring, storing, analyzing, communicating, predicting, and displaying of a physiological event of the patient. The injectable detecting system **12** can be sealed, such as housed in a hermetically sealed package. In one embodiment, at least a portion of the sealed packages include a power source, a memory, logic resources and a wireless communication device. In one embodiment, an antenna is included that is exterior to the sealed package of the injectable detecting system **12**. In one embodiment, the sensors **14** include, flex circuits, thin film resistors, organic transistors and the like. The sensors **14** can include ceramics, titanium PEEK, along with a silicon, PU or other insulative adherent sealant, to enclose the electronics. Additionally, the injectable detecting system **12** can include drug eluting coatings, including but not limited to, an antibiotic, anti-inflammatory agent and the like.

[0076] A wide variety of different sensors **14** can be utilized, including but not limited to, bioimpedance, heart rate, heart rhythm, HRV, HRT, heart sounds, respiration rate, respiration rate variability, respiratory sounds, SpO<sub>2</sub>, blood pressure, activity, posture, wake/sleep, orthopnea, temperature, heat flux, an accelerometer, glucose sensor, other chemical sensors associated with cardiac conditions, and the like. A variety of activity sensors can be utilized, including but not limited to a, ball switch, accelerometer, minute ventilation, HR, bioimpedance noise, skin temperature/heat flux, BP, muscle noise, posture and the like.

[0077] The output of the sensors **14** can have multiple features to enhance physiological sensing performance. These multiple features have multiple sensing vectors that can include redundant vectors. The sensors **14** can include current

delivery electrodes and sensing electrodes. Size and shape of current delivery electrodes, and the sensing electrodes, can be optimized to maximize sensing performance. The system **10** can be configured to determine an optimal sensing configuration and electronically reposition at least a portion of a sensing vector of a sensing electrode. The multiple features enhance the system's **10** ability to determine an optimal sensing configuration and electronically reposition sensing vectors. In one embodiment, the sensors **14** can be partially masked to minimize contamination of parameters sensed by the sensors **14**.

[0078] The size and shape of current delivery electrodes, for bioimpedance, and sensing electrodes can be optimized to maximize sensing performance. Additionally, the outputs of the sensors **14** can be used to calculate and monitor blended indices. Examples of the blended indices include but are not limited to, heart rate (HR) or respiratory rate (RR) response to activity, HR/RR response to posture change, HR+RR, HR/RR+bioimpedance, and/or minute ventilation/accelerometer and the like.

[0079] The sensors **14** can be cycled in order to manage energy, and different sensors **14** can sample at different times. By way of illustration, and without limitation, instead of each sensor **14** being sampled at a physiologically relevant interval, e.g. every 30 seconds, one sensor **14** can be sampled at each interval, and sampling cycles between available sensors.

[0080] By way of illustration, and without limitation, the sensors **14** can sample 5 seconds for every minute for ECG, once a second for an accelerometer sensor, and 10 seconds for every 5 minutes for impedance.

[0081] In one embodiment, a first sensor **14** is a core sensor **14** that continuously monitors and detects, and a second sensor **14** verifies a physiological status in response to the core sensor **14** raising a flag. Additionally, some sensors **14** can be used for short term tracking, and other sensors **14** used for long term tracking.

[0082] The injectable detecting system **12** is inserted into the patient by a variety of means, including but not limited to, catheter delivery, blunt tunneling, insertion with a needle, by injection, with a gun or syringe device with a stiffening wire and stylet and the like. The sensors **14** can be inserted in the patient in a non-sterile or sterile setting, non-surgical setting or surgical setting, injected with or without anesthesia and injected with or without imaging assistance. The injectable detecting system **12** can be anchored in the patient by a variety of means including but not limited to, barbs, anchors, tissue adhesion pads, suture loops.

[0083] The injectable detecting system **12** can come in a variety of different form factors including but not limited to, cylinder, dog-bone, half dog-bone, trapezoidal cross-section, semicircular cross-section, star-shaped cross-section, v-shaped cross-section, L-shaped, canted, W shaped, or in other shapes that assist in their percutaneous delivery, S-shaped, sine-wave shaped, J-shaped, any polygonal shape, helical/spiral, fin electrodes, and linear device with a radius of curvature to match a radius of the injection site and the like. Further, the injectable detecting system **12** can have flexible body configurations. Additionally, the injectable detecting system **12** can be configured to deactivate selected sensors **14** to reduce redundancy.

[0084] The sensors **14** can be made of a variety of materials, including but not limited to, silicone, polyurethane, Nitinol, a biocompatible material, a bioabsorbable material and the like. Electrode sensors **14** can have a variety of different

conductors, including but not limited to, platinum, MP35N which is a nickel-cobalt-chromium-molybdenum alloy, MP35N/Ag core, platinum/tantalum core, stainless steel, titanium and the like. The sensors 14 can have insulative materials, including but not limited to, polyetheretherketone (PEEK), ethylene-tetrafluoroethylene (ETFE), polytetrafluoroethylene (PTFE), polyimide, silicon, polyurethane, and the like. Further, the sensors 14 can have openings, or an absorbent material, configured to sample a hydration level or electrolyte level in a surrounding tissue site at the location of the sensor 14. The sensor 14 electrodes can be made of a variety of materials, including but not limited to platinum, iridium, titanium, and the like. Electrode coatings can be included, such as iridium oxide, platinum black, TiN, and the like.

[0085] The injectable detecting system 12 can include one or more rechargeable batteries 36 that can be transcutaneously chargeable with an external unit.

[0086] Referring to FIG. 6, in one embodiment, an external device 38, including a medical treatment device, is coupled to the injectable detecting system 12. The external device 38 can be coupled to a monitoring unit 22 that is part of the injectable detecting system 12, or in direct communication with the sensors 14. A variety of different external devices 38 can be used, including but not limited to, a weight scale, blood pressure cuff, cardiac rhythm management device, a medical treatment device, medicament dispenser, glucose monitor, insulin pump, drug delivery pumps, drug delivery patches, and the like. Suitable cardiac rhythm management devices include but are not limited to, Boston Scientific's Latitude system, Medtronic's CareLink system, St. Jude Medical's HouseCall system and the like. Such communication may occur directly or via an external translator unit.

[0087] The external device 38 can be coupled to an auxiliary input of the monitoring unit 22 at the injectable detecting system 12 or to the monitoring system 22 at the remote monitoring system 18. Additionally, an automated reader can be coupled to an auxiliary input in order to allow a single monitoring unit 22 to be used by multiple patients. As previously mentioned above, the monitoring unit 22 can be at the remote monitoring system 18 and each patient can have a patient identifier (ID) including a distinct patient identifier. In addition, the ID identifier can also contain patient specific configuration parameters. The automated reader can scan the patient identifier ID and transmit the patient ID number with a patient data packet such that the main data collection station can identify the patient.

[0088] It will be appreciated that other medical treatment devices can also be used. The injectable detecting system 12 can communicate wirelessly with the external devices 38 in a variety of ways including but not limited to, a public or proprietary communication standard and the like. The injectable detecting system 12 can be configured to serve as a communication hub for multiple medical devices, coordinating sensor data and therapy delivery while transmitting and receiving data from the remote monitoring system 18.

[0089] In one embodiment, the injectable detecting system 12 coordinate data sharing between the external systems 38 allowing for sensor integration across devices. The coordination of the injectable detecting system 12 provides for new pacing, sensing, defibrillation vectors, and the like.

[0090] In one embodiment, the processor 20 is included in the monitoring unit 22 and the external device 38 is in direct communication with the monitoring unit 22.

[0091] In another embodiment, illustrated in FIG. 7, a notification device 42 is coupled to the injectable detecting system 12 and the remote monitoring system 18. The notification device 42 is configured to provide notification when values received from the sensors 14 are not within acceptable physiological ranges. The notification device 42 can be at the remote monitoring system 18 or at the monitoring unit 22 that is part of the injectable detecting system 12. A variety of notification devices 42 can be utilized, including but not limited to, a visible patient indicator, an audible alarm, an emergency medical service notification, a call center alert, direct medical provider notification and the like. The notification device 42 provides notification to a variety of different entities, including but not limited to, the patient, a caregiver, the remote monitoring system, a spouse, a family member, a medical provider, from one device to another device such as the external device 38, and the like.

[0092] Notification can be according to a preset hierarchy. By way of illustration, and without limitation, the preset hierarchy can be, patient notification first and medical provider second, patient notification second and medical provider first, and the like. Upon receipt of a notification, a medical provider, the remote monitoring system 18, or a medical treatment device can trigger a high-rate sampling of physiological parameters for alert verification.

[0093] The system 10 can also include an alarm 46, that can be coupled to the notification device 42, for generating a human perceptible signal when values received from the sensors 14 are not within acceptable physiological ranges. The alarm 46 can trigger an event to render medical assistance to the patient, provide notification as set forth above, continue to monitor, wait and see, and the like.

[0094] When the values received from the sensors 14 are not within acceptable physiological ranges the notification is with the at least one of, the patient, a spouse, a family member, a caregiver, a medical provider and from one device to another device, to allow for therapeutic intervention to prevent decompensation.

[0095] In another embodiment, the injectable detecting system 12 can switch between different modes, wherein the modes are selected from at least one of, a stand alone mode with communication directly with the remote monitoring system 18, communication with an implanted device, communication with a single implanted device, coordination between different devices (external systems) coupled to the plurality of sensors and different device communication protocols.

[0096] By way of illustration, and without limitation, the patient can be a congestive heart failure patient. Heart failure status is determined by a weighted combination change in sensor outputs and be determined by a number of different means, including but not limited to, (i) when a rate of change of at least two sensor outputs is an abrupt change in the sensor outputs as compared to a change in the sensor outputs over a longer period of time, (ii) by a tiered combination of at least a first and a second sensor output, with the first sensor output indicating a problem that is then verified by at least a second sensor output, (iii) by a variance from a baseline value of sensor outputs, and the like. The baseline values can be defined in a look up table.

[0097] In another embodiment, heart failure status is determined using three or more sensors by at least one of, (i) when the first sensor output is at a value that is sufficiently different from a baseline value, and at least one of the second and third

sensor outputs is at a value also sufficiently different from a baseline value to indicate heart failure status, (ii) by time weighting the outputs of the first, second and third sensors, and the time weighting indicates a recent event that is indicative of the heart failure status and the like.

[0098] In one embodiment, the wireless communication device 16 can include a modem, a controller to control data supplied by the injectable detecting system 12, serial interface, LAN or equivalent network connection and a wireless transmitter. Additionally, the wireless communication device 16 can include a receiver and a transmitter for receiving data indicating the values of the physiological event detected by the plurality of sensors, and for communicating the data to the remote monitoring system 18. Further, the wireless communication device 16 can have data storage for recording the data received from the injectable detecting system 12 and an access device for enabling access to information recording in the data storage from the remote monitoring system 18.

[0099] In various embodiments, the remote monitoring system 18 can include a receiver, a transmitter and a display for displaying data representative of values of the one physiological event detected by the injectable detecting system 12. The remote monitoring system can also include a data storage mechanism that has acceptable ranges for physiological values stored therein, a comparator for comparing the data received from the injectable detecting system 12 with the acceptable ranges stored in the data storage device and a portable computer. The remote monitoring system 18 can be a portable unit with a display screen and a data entry device for communicating with the wireless communication device 16.

[0100] Referring now to FIG. 8, for each sensor 14, a sensor lead 112 and 114 conveys signals from the sensor 14 to the monitoring unit 22 at the injectable detecting system 12, or through the wireless communication device 16 to the remote monitoring system 18.

[0101] In one embodiment, each signal from a sensor 14 is first passed through a low-pass filter 116, at the injectable detecting system 12 or at the remote monitoring system 18, to smooth the signal and reduce noise. The signal is then transmitted to an analog-to-digital converter 118A, which transforms the signals into a stream of digital data values that can be stored in a digital memory 118B. From the digital memory 118B, data values are transmitted to a data bus 120, along which they are transmitted to other components of the circuitry to be processed and archived. From the data bus 120, the digital data can be stored in a non-volatile data archive memory. The digital data can be transferred via the data bus 120 to the processor 20, which processes the data based in part on algorithms and other data stored in a non-volatile program memory.

[0102] The injectable detecting system 12 can also include a power management module 122 configured to power down certain components of the system, including but not limited to, the analog-to-digital converters 118A and 124, digital memories 118B and the non-volatile data archive memory and the like, between times when these components are in use. This helps to conserve battery power and thereby extend the useful life. Other circuitry and signaling modes may be devised by one skilled in the art.

[0103] As can be seen in FIG. 9, a control unit 126 is included at the detecting system 12, the remote monitoring system 18, or at both locations.

[0104] In one embodiment, the control unit 126 can be a microprocessor, for example, a Pentium or 486 processor. The control unit 126 can be coupled to the sensors 14 directly at the injectable detecting system 12, indirectly at the injectable detecting system 12 or indirectly at the remote monitoring system 18. Additionally the control unit 126 can be coupled to one or more devices, for example, a blood pressure monitor, cardiac rhythm management device, scale, a device that dispenses medication, a device that can indicate the medication has been dispensed, and the like.

[0105] The control unit 126 can be powered by AC inputs which are coupled to internal AC/DC converters 134 that generate multiple DC voltage levels. After the control unit 126 has collected the patient data from the sensors 14, the control unit 126 encodes the recorded patient data and transmits the patient data through the wireless communication device 16 to transmit the encoded patient data to a wireless network storage unit 128 at the remote monitoring system 18, as shown in FIG. 10. In another embodiment, wireless communication device 16 transmits the patient data from the injectable detecting system 12 to the control unit 126 when it is at the remote monitoring system 18.

[0106] Every time the control unit 126 plans to transmit patient data to a main data collection station 130, located at the remote monitoring system 18, the control unit 126 attempts to establish a communication link. The communication link can be wireless, wired, or a combination of wireless and wired for redundancy, e.g., the wired link checks to see if a wireless communication can be established. If the wireless communication link 16 is available, the control unit 126 transmits the encoded patient data through the wireless communication device 16. However, if the wireless communication device 16 is not available for any reason, the control unit 126 waits and tries again until a link is established.

[0107] Referring now to FIG. 11, one embodiment of an internal structure of a main data collection station 130, at the remote monitoring system 18, is illustrated. The patient data can be transmitted by the remote monitoring system 18 by either the wireless communication device 16 or conventional modem to the wireless network storage unit 128. After receiving the patient data, the wireless network storage unit 128 can be accessed by the main data collection station 130. The main data collection station 130 allows the remote monitoring system 18 to monitor the patient data of numerous patients from a centralized location without requiring the patient or a medical provider to physically interact with each other.

[0108] The main data collection station 130 can include a communications server 136 that communicates with the wireless network storage unit 128. The wireless network storage unit 128 can be a centralized computer server that includes a unique, password protected mailbox assigned to and accessible by the main data collection station 130. The main data collection station 130 contacts the wireless network storage unit 128 and downloads the patient data stored in a mailbox assigned to the main data collection station 130.

[0109] Once the communications server 136 has formed a link with the wireless network storage unit 128, and has downloaded the patient data, the patient data can be transferred to a database server 138. The database server 138 includes a patient database 140 that records and stores the patient data of the patients based upon identification included in the data packets sent by each of the monitoring units 22. For example, each data packet can include an identifier.

[0110] Each data packet transferred from the remote monitoring system 18 to the main data collection station 130 does not have to include any patient identifiable information. Instead, the data packet can include the serial number assigned to the specific injectable detecting system 12. The serial number associated with the detecting system 12 can then be correlated to a specific patient by using information stored on the patient database 138. In this manner, the data packets transferred through the wireless network storage unit 128 do not include any patient-specific identification. Therefore, if the data packets are intercepted or improperly routed, patient confidentiality can not be breached.

[0111] The database server 138 can be accessible by an application server 142. The application server 142 can include a data adapter 144 that formats the patient data information into a form that can be viewed over a conventional web-based connection. The transformed data from the data adapter 144 can be accessible by propriety application software through a web server 146 such that the data can be viewed by a workstation 148. The workstation 148 can be a conventional personal computer that can access the patient data using proprietary software applications through, for example, HTTP protocol, and the like.

[0112] The main data collection station further can include an escalation server 150 that communicates with the database server 138. The escalation server 150 monitors the patient data packets that are received by the database server 138 from the monitoring unit 22. Specifically, the escalation server 150 can periodically poll the database server 138 for unacknowledged patient data packets. The patient data packets are sent to the remote monitoring system 18 where the processing of patient data occurs. The remote monitoring system 18 communicates with a medical provider in the event that an alert is required. If data packets are not acknowledged by the remote monitoring system 18. The escalation server 150 can be programmed to automatically deliver alerts to a specific medical provider if an alarm message has not been acknowledged within a selected time period after receipt of the data packet.

[0113] The escalation server 150 can be configured to generate the notification message to different people by different modes of communication after different delay periods and during different time periods.

[0114] The main data collection station 130 can include a batch server 152 connected to the database server 138. The batch server 152 allows an administration server 154 to have access to the patient data stored in the patient database 140. The administration server 154 allows for centralized management of patient information and patient classifications.

[0115] The administration server 154 can include a batch server 156 that communicates with the batch server 152 and provides the downloaded data to a data warehouse server 158. The data warehouse server 158 can include a large database 160 that records and stores the patient data.

[0116] The administration server 154 can further include an application server 162 and a maintenance workstation 164 that allow personnel from an administrator to access and monitor the data stored in the database 160.

[0117] The data packet utilized in the transmission of the patient data can be a variable length ASCII character packet, or any generic data formats, in which the various patient data measurements are placed in a specific sequence with the specific readings separated by commas. The control unit 126 can convert the readings from each sensor 14 into a standardized sequence that forms part of the patient data packet. In this

manner, the control unit 126 can be programmed to convert the patient data readings from the sensors 14 into a standardized data packet that can be interpreted and displayed by the main data collection station 130 at the remote monitoring system 18.

[0118] Referring now to the flow chart of FIG. 12, if an external device 38 fails to generate a valid reading, as illustrated in step A, the control unit 126 fills the portion of the patient data packet associated with the external device 38 with a null indicator. The null indicator can be the lack of any characters between commas in the patient data packet. The lack of characters in the patient data packet can indicate that the patient was not available for the patient data recording. The null indicator in the patient data packet can be interpreted by the main data collection station 130 at the remote monitoring system 18 as a failed attempt to record the patient data due to the unavailability of the patient, a malfunction in one or more of the sensors 14, or a malfunction in one of the external devices 38. The null indicator received by the main data collection station 130 can indicate that the transmission from the injectable detecting system 12 to the remote monitoring system 18 was successful. In one embodiment, the integrity of the data packet received by the main data collection station 130 can be determined using a cyclic redundancy code, CRC-16, check sum algorithm. The check sum algorithm can be applied to the data when the message can be sent and then again to the received message.

[0119] After the patient data measurements are complete, the control unit 126 displays the sensor data, including but not limited to blood pressure cuff data and the like, as illustrated by step B. In addition to displaying this data, the patient data can be placed in the patient data packet, as illustrated in step C.

[0120] As previously described, the system 10 can take additional measurements utilizing one or more auxiliary or external devices 38 such as those mentioned previously. Since the patient data packet has a variable length, the auxiliary device patient information can be added to the patient data packet being compiled by the remote monitoring unit 22 during patient data acquisition period being described. Data from the external devices 38 is transmitted by the wireless communication device 16 to the remote monitoring system 18 and can be included in the patient data packet.

[0121] If the remote monitoring system 18 can be set in either the auto mode or the wireless only mode, the remote monitoring unit 22 can first determine if there can be an internal communication error, as illustrated in step D.

[0122] A no communication error can be noted as illustrated in step E. If a communication error is noted the control unit 126 can proceed to wireless communication device 16 or to a conventional modem transmission sequence, as will be described below. However, if the communication device is working, the control unit 126 can transmit the patient data information over the wireless network 16, as illustrated in step F. After the communication device has transmitted the data packet, the control unit 126 determines whether the transmission was successful, as illustrated in step G. If the transmission has been unsuccessful only once, the control unit 126 retries the transmission. However, if the communication device has failed twice, as illustrated in step H, the control unit 126 proceeds to the conventional modem process if the remote monitoring unit 22 was configured in an auto mode.

**[0123]** When the control unit **126** is at the injectable detecting system **12**, and the control unit **126** transmits the patient data over the wireless communication device **16**, as illustrated in step I, if the transmission has been successful, the display of the remote monitoring unit **22** can display a successful message, as illustrated in step J. However, if the control unit **126** determines in step K that the communication of patient data has failed, the control unit **126** repeats the transmission until the control unit **126** either successfully completes the transmission or determines that the transmission has failed a selected number of times, as illustrated in step L. The control unit **126** can time out the and a failure message can be displayed, as illustrated in steps M and N. Once the transmission sequence has either failed or successfully transmitted the data to the main data collection station, the control unit **126** returns to a start program step O.

**[0124]** As discussed previously, the patient data packets are first sent and stored in the wireless network storage unit **128**. From there, the patient data packets are downloaded into the main data collection station **130**. The main data collection station **130** decodes the encoded patient data packets and records the patient data in the patient database **140**. The patient database **140** can be divided into individual storage locations for each patient such that the main data collection station **130** can store and compile patient data information from a plurality of individual patients.

**[0125]** A report on the patient's status can be accessed by a medical provider through a medical provider workstation that is coupled to the remote monitoring system **18**. Unauthorized access to the patient database can be prevented by individual medical provider usernames and passwords to provide additional security for the patient's recorded patient data.

**[0126]** The main data collection station **130** and the series of work stations **148** allow the remote monitoring system **18** to monitor the daily patient data measurements taken by a plurality of patients reporting patient data to the single main data collection station **130**. The main data collection station **130** can be configured to display multiple patients on the display of the workstations **148**. The internal programming for the main data collection station **130** can operate such that the patients are placed in a sequential top-to-bottom order based upon whether or not the patient can be generating an alarm signal for one of the patient data being monitored. For example, if one of the patients monitored by monitoring system **130** has a blood pressure exceeding a predetermined maximum amount, this patient can be moved toward the top of the list of patients and the patient's name and/or patient data can be highlighted such that the medical personnel can quickly identify those patients who may be in need of medical assistance. By way of illustration, and without limitation, the following paragraphs is a representative order ranking method for determining the order which the monitored patients are displayed:

**[0127]** Alarm Display Order Patient Status Patients are then sorted 1 Medical Alarm Most alarms violated to least alarms violated, then oldest to newest 2 Missing Data Alarm Oldest to newest 3 Late Oldest to newest 4 Reviewed Medical Alarms Oldest to newest 5 Reviewed Missing Data Oldest to newest 6 Reviewed Null Oldest to newest 7 NDR Oldest to newest 8 Reviewed NDR Oldest to newest

**[0128]** As listed in the above, the order of patients listed on the display can be ranked based upon the seriousness and number of alarms that are registered based upon the latest patient data information. For example, if the blood pressure of

a single patient exceeds the tolerance level and the patient's heart rate also exceeds the maximum level, this patient will be placed above a patient who only has one alarm condition. In this manner, the medical provider can quickly determine which patient most urgently needs medical attention by simply identifying the patient's name at the top of the patient list. The order which the patients are displayed can be configurable by the remote monitoring system **18** depending on various preferences.

**[0129]** As discussed previously, the escalation server **150** automatically generates a notification message to a specified medical provider for unacknowledged data packets based on user specified parameters.

**[0130]** In addition to displaying the current patient data for the numerous patients being monitored, the software of the main data collection station **130** allows the medical provider to trend the patient data over a number of prior measurements in order to monitor the progress of a particular patient. In addition, the software allows the medical provider to determine whether or not a patient has been successful in recording their patient data as well as monitor the questions being asked by the remote monitoring unit **22**.

**[0131]** As previously mentioned, the system **10** uses an intelligent combination of sensors to enhance detection and prediction capabilities. Electrocardiogram circuitry can be coupled to the sensors **14**, or electrodes, to measure an electrocardiogram signal of the patient. An accelerometer can be mechanically coupled, for example adhered or affixed, to the sensors **14**, adherent patch and the like, to generate an accelerometer signal in response to at least one of an activity or a position of the patient. The accelerometer signals improve patient diagnosis, and can be especially useful when used with other signals, such as electrocardiogram signals and impedance signals, including but not limited to, hydration respiration, and the like. Mechanically coupling the accelerometer to the sensors **14**, electrodes, for measuring impedance, hydration and the like can improve the quality and/or usefulness of the impedance and/or electrocardiogram signals. By way of illustration, and without limitation, mechanical coupling of the accelerometer to the sensors **14**, electrodes, and to the skin of the patient can improve the reliability, quality and/or accuracy of the accelerometer measurements, as the sensor **14**, electrode, signals can indicate the quality of mechanical coupling of the patch to the patient so as to indicate that the device is connected to the patient and that the accelerometer signals are valid. Other examples of sensor interaction include but are not limited to, (i) orthopnea measurement where the breathing rate is correlated with posture during sleep, and detection of orthopnea, (ii) a blended activity sensor using the respiratory rate to exclude high activity levels caused by vibration (e.g. driving on a bumpy road) rather than exercise or extreme physical activity, (iii) sharing common power, logic and memory for sensors, electrodes, and the like.

**[0132]** FIG. **13** shows one embodiment of an injection system **200** for use with multiple injectable detecting systems **12** that includes a body having a magazine **205** with several injectable detecting systems **12** loaded therein. A needle portion of the injection system **200** can be placed against the tissue **210**, as shown. A handle **215** can be pulled proximally **220** and a pusher is advanced to inject one of the injectable detecting systems **12** out of the needle end into the patient **40**, and injectable detecting systems **12** in the magazine **205** are

advanced such that the next injectable detecting system 12 is ready for injection at a subsequent location.

[0133] FIG. 14 shows one embodiment of an injection system 250 that includes a body with a needle 255 configured to hold one or more injectable detecting systems 12. The needle 255 includes a bevel needle shaped tip 265, that is inserted into the tissue with the injectable detecting system 12 loaded into the needle 255. A pusher 265 is advanced distally in the body to advance the injectable detecting system 12 into the tissue after the needle tip has penetrated the tissue

[0134] While the invention is susceptible to various modifications and alternative constructions, certain illustrated embodiments thereof are shown in the drawings and have been described above in detail. It should be understood, however, that there is no intention to limit the invention to the specific form or forms disclosed, but on the contrary, the intention is to cover all modifications, alternative constructions, and equivalents falling within the spirit and scope of the invention.

1. An injectable device for use in subcutaneous physiological monitoring of a patient, the injectable device comprising:

a body;

a plurality of sensors that provide an indication of at least one physiological event of a patient, wherein the plurality of sensors includes two or more electrodes in contact with tissue of the patient; and

a monitoring unit located within the body and coupled to the plurality of sensors and configured to monitor a physiologic signal of the patient using the electrodes, wherein the physiologic signal includes an impedance signal related to hydration of tissue of the patient and wherein the monitoring unit is further configured to, based at least in part on the impedance signal measured from the patient, detect an impending cardiac decompensation of the patient.

2. The injectable device of claim 1, further including electrocardiogram circuitry coupled to the two or more electrodes to measure an electrocardiogram signal of the patient.

3. The injectable device of claim 2, wherein the monitoring unit utilizes the measured impedance signal to monitor a respiration signal associated with the patient.

4. The injectable device of claim 3, wherein the monitoring unit compares the monitored hydration, the respiration signal and the electrocardiogram signal to baseline values established for each, wherein the monitoring unit sets a flag indicating cardiac decompensation based on a combination of the compared values.

5. The injectable device of claim 1, further including an accelerometer located within the body that generates an activity signal in response to at least one of a activity or a position of the patient.

6. The injectable device of claim 5, wherein the accelerometer is a three-axis accelerometer configured to measure at least one inclination, a position, an orientation, and an acceleration of the patient in three dimensions.

7. The injectable device of claim 5, wherein the accelerometer is comprised of at least one of a piezoelectric accelerometer, a capacitive accelerometer, or an electromechanical accelerometer.

8. The injectable device of claim 5, wherein the monitoring unit utilizes activity data received from the accelerometer to detect physiological events and identify patient states when data collection is desirable

9. The injectable device of claim 8, wherein patient states in which data collection is desirable include rest states.

10. The injectable device of claim 1, wherein the body has a proximal end and a distal end, wherein the distal end is shaped to penetrate tissue.

11. An injectable device for use in subcutaneous physiological monitoring of a patient, the injectable device comprising:

a hermetically sealed body;

a plurality of sensors that provide an indication of at least one physiological event of a patient, wherein the plurality of sensors includes an accelerometer located within the body that generates an activity signal in response to at least one of a activity or a position of the patient and at least two electrodes in contact with tissue of the patient for monitoring a physiological signal associated with the patient; and

a monitoring unit located within the body and coupled to the accelerometer and the at least two electrodes, wherein the physiologic signal includes an impedance signal related to hydration of tissue of the patient and wherein the monitoring unit is further configured to, based at least in part on the impedance signal measured from the patient and the activity level of the patient, detect an impending cardiac decompensation of the patient.

12. The injectable device of claim 11, wherein the accelerometer is a three-axis accelerometer configured to measure at least one inclination, a position, an orientation, and an acceleration of the patient in three dimensions.

13. The injectable device of claim 11, wherein the monitoring unit utilizes the monitored activity level of the patient to identify patient states when data collection is appropriate.

14. The injectable device of claim 13, wherein patient states in which data collection is appropriate includes rest states.

15. The injectable device of claim 11, further including electrocardiogram circuitry coupled to the two or more electrodes to measure an electrocardiogram signal of the patient.

16. The injectable device of claim 15, wherein the monitoring unit utilizes the measured impedance signal to monitor a respiration signal associated with the patient.

17. The injectable device of claim 15, wherein the monitoring unit compares the monitored hydration, the respiration signal and the electrocardiogram signal to baseline values established for each, wherein the monitoring unit sets a flag indicating cardiac decompensation based on a combination of the compared values.

\* \* \* \* \*

专利名称(译)	可注射的生理监测系统		
公开(公告)号	<a href="#">US20160045169A1</a>	公开(公告)日	2016-02-18
申请号	US14/921827	申请日	2015-10-23
[标]申请(专利权)人(译)	美敦力监控公司		
申请(专利权)人(译)	美敦力公司监测, INC.		
当前申请(专利权)人(译)	美敦力公司监测, INC.		
[标]发明人	MAZAR SCOTT T BLY MARK J		
发明人	MAZAR, SCOTT T. BLY, MARK J.		
IPC分类号	A61B5/00 A61B5/0205 A61B5/042		
CPC分类号	A61B5/7282 A61B5/0422 A61B5/4875 A61B5/0205 A61B5/1118 A61B2562/04 A61B2562/0219 A61B2562/16 A61B2562/06 A61B5/686		
优先权	61/055666 2008-05-23 US 60/972336 2007-09-14 US 60/972537 2007-09-14 US 60/972329 2007-09-14 US 60/972354 2007-09-14 US		
其他公开文献	US9538960		
外部链接	<a href="#">Espacenet</a> <a href="#">USPTO</a>		

摘要(译)

一种用于患者的皮下生理监测的可注射装置包括主体, 多个传感器和监测单元。多个传感器提供患者的至少一个生理事件的指示, 其中多个传感器包括与患者的组织接触的两个或更多个电极。监测单元位于体内并且耦合到多个传感器并且被配置为使用电极监测患者的生理信号, 其中生理信号包括与患者组织的水合相关的阻抗信号并且其中监测该单元还被配置为至少部分地基于从患者测量的阻抗信号来检测患者即将发生的心脏代偿失调。

