



US 20140081166A1

(19) **United States**  
(12) **Patent Application Publication**  
**LANG et al.**

(10) **Pub. No.: US 2014/0081166 A1**  
(43) **Pub. Date: Mar. 20, 2014**

(54) **RESPIRATION DETECTING  
ARRANGEMENT**

**Publication Classification**

(71) Applicant: **ResMed R&D Germany GmbH,**  
Martinsried (DE)

(51) **Int. Cl.**  
*A61B 5/113* (2006.01)  
*A61B 5/11* (2006.01)  
*A61B 5/00* (2006.01)

(72) Inventors: **Bernd Christoph LANG,** Graefelfing  
(DE); **Stefan SCHATZL,** Weilheim  
(DE)

(52) **U.S. Cl.**  
CPC ..... *A61B 5/1135* (2013.01); *A61B 5/6823*  
(2013.01); *A61B 5/6831* (2013.01); *A61B*  
*5/1118* (2013.01)  
USPC ..... **600/534**

(73) Assignee: **ResMed R&D Germany GmbH,**  
Martinsried (DE)

(57) **ABSTRACT**

(21) Appl. No.: **14/082,532**

The present application is directed to a detector to detect or generate measuring signals that are indicative of the respiration of a person, wherein said detector can be used advantageously in view of hygiene and stands out due to a simple and robust configuration. According to a first aspect, the detector detects a signal that is indicative of the activity of the respiratory muscles of a person to be examined, the detector comprising a band which, in the application position, is passed around a torso region which widens and narrows when the person to be examined breathes, as well as a structure that is included in the band and loaded in accordance with the narrowing or widening of the torso region. The structure is configured such that it causes a change in the volume of a measuring space device depending on a tensile force. It is thus advantageously possible to detect or measure the forces acting on the band in a non-electric manner and, on the basis of this detection or measurement, draw conclusions relating to the widening or narrowing of the torso.

(22) Filed: **Nov. 18, 2013**

**Related U.S. Application Data**

(63) Continuation of application No. 13/112,681, filed on May 20, 2011, now Pat. No. 8,628,481, which is a continuation of application No. 11/919,496, filed on Jan. 17, 2008, now Pat. No. 7,967,760, filed as application No. PCT/EP2006/003754 on Apr. 24, 2006.

**Foreign Application Priority Data**

(30) Apr. 29, 2005 (DE) ..... 102005020162.8

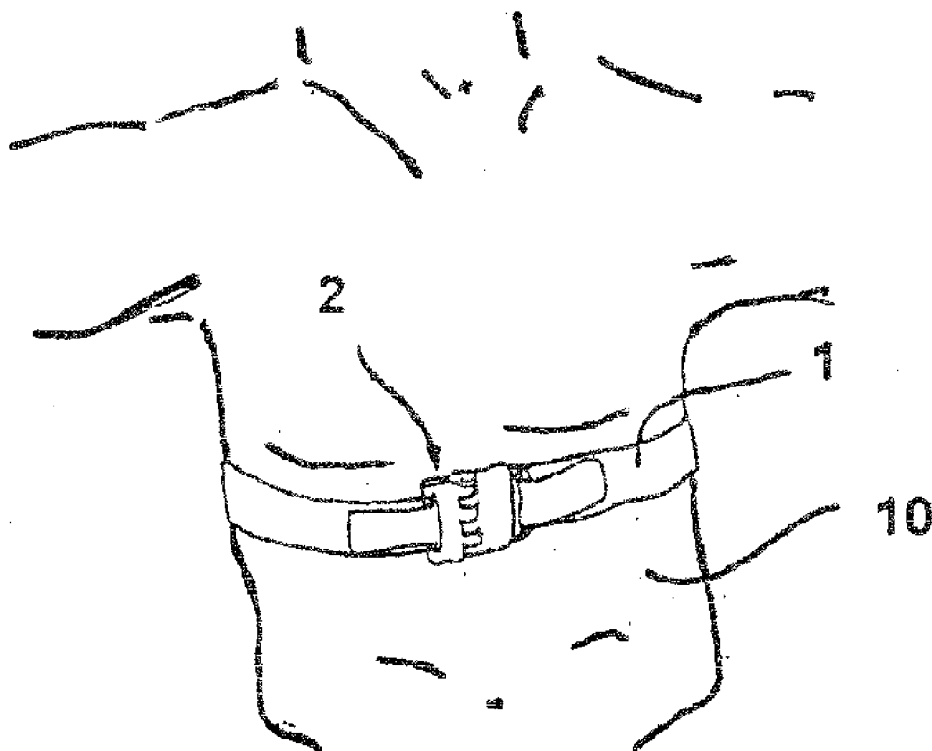

Fig.1

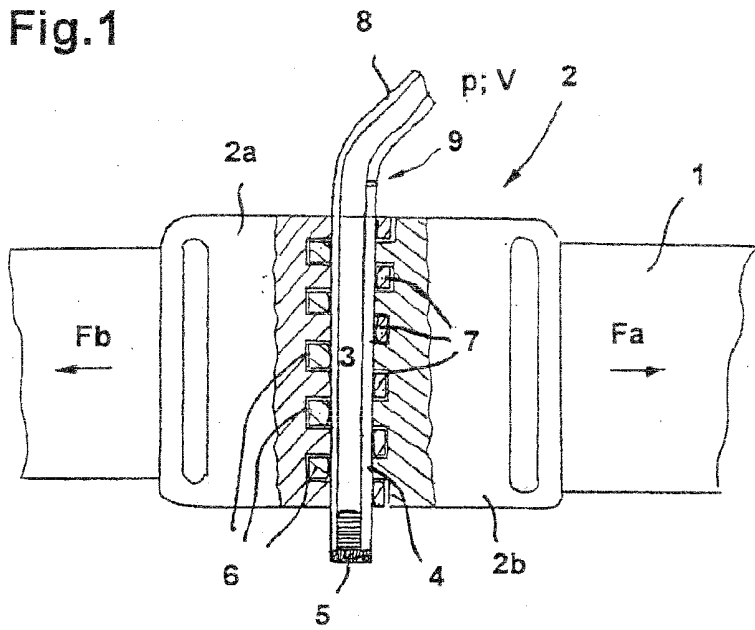
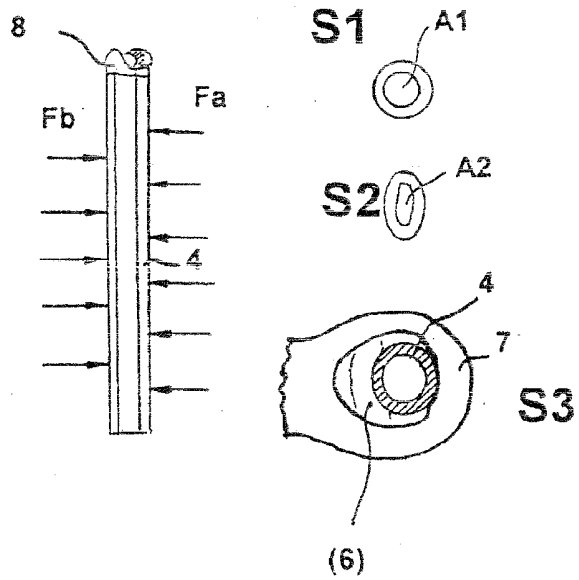

Fig.2



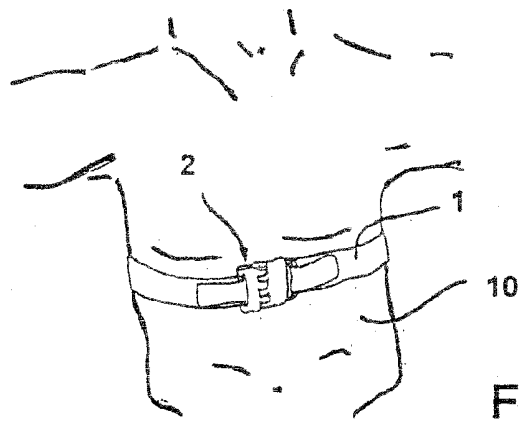

Fig.3

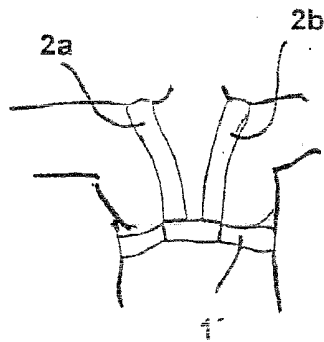

Fig.4

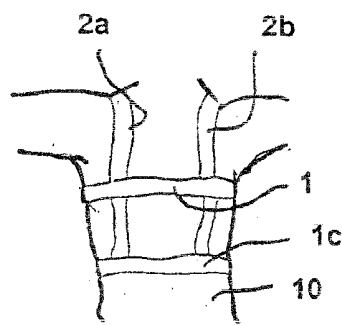

Fig.5

Fig.6

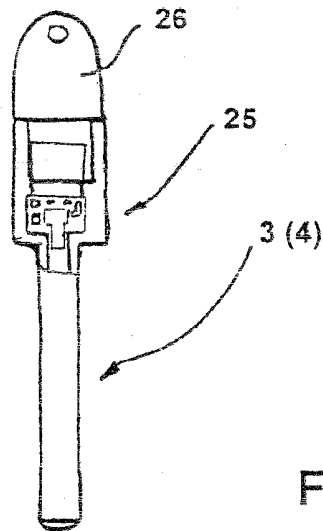
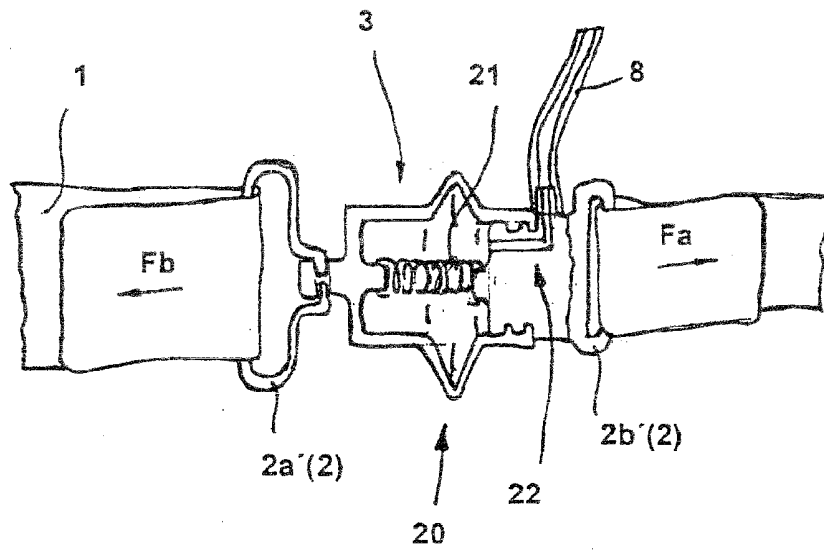

Fig.7

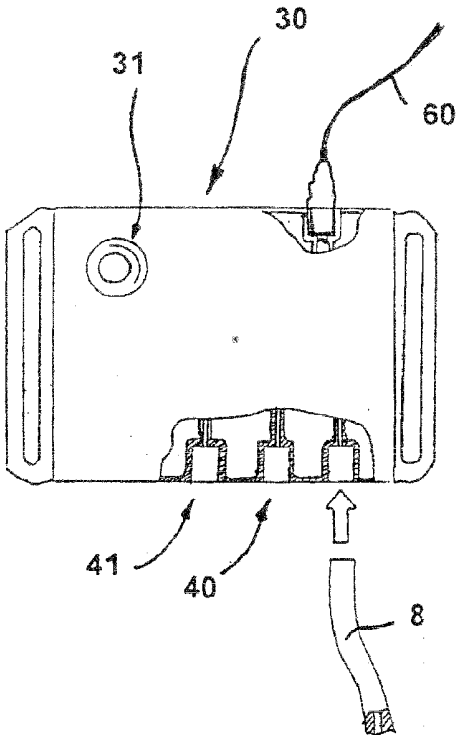

Fig.8

## RESPIRATION DETECTING ARRANGEMENT

[0001] This application is a continuation of application Ser. No. 13/112,681, filed on May 20, 2011, now allowed, which is continuation of application Ser. No. 11/919,496 filed Jan. 17, 2008, now U.S. Pat. No. 7,967,760, issued on Jun. 28, 2011, which is a National Phase of International Application No. PCT/EP2006/003754 filed Apr. 24, 2006, and claims foreign priority to German Application No. 102005020162.8 filed Apr. 29, 2005, the entire contents of each of which are hereby incorporated by reference.

[0002] The present invention is directed to a detecting means for detecting or generating measuring signals that are indicative of the respiration of a person.

[0003] It is the object of the present invention to provide a detecting means for detecting or generating signals that are indicative of the respiration of a person, wherein said detecting means can be used advantageously in view of hygiene and stands out due to a simple and robust configuration.

[0004] According to a first aspect of the present invention, this object is achieved by a detecting means for detecting a signal that is indicative of the activity of the respiratory muscles of a person to be examined, said means comprising a band means which, in the application position, is passed around a torso region which widens and narrows in response to the respiration of the person to be examined, as well as a structure that is included in the band means and loaded in accordance with the narrowing or widening of the torso region, wherein said structure is configured such that it causes a change in the volume of a measuring space means depending on a tensile force.

[0005] It is thus advantageously possible to detect or measure the forces acting on the band means in a non-electric manner and, on the basis of this detection or measurement, draw conclusions relating to the widening or narrowing of the torso.

[0006] In accordance with a particularly preferable embodiment of the present invention, the structure is configured as a buckle means. Said buckle means can be realized like a belt buckle and comprise bracket portions through which the respective end portions of the band means are passed. The buckle means can comprise adjusting means, e.g., clamping means or adjusting eyelets which allow a respective fixing, in particular clamping of the end portions of the band means.

[0007] In accordance with a particularly preferable embodiment of the present invention, the detecting means is configured such that the change in the volume of the measuring space means is caused by squeezing or compressing an elastically deformable chamber means. Particularly advantageously, said chamber means can be realized by a tube portion.

[0008] It is possible to pass the tube portion in such a manner through the buckle means that the tube portion is squeezed in accordance with the respiration-synchronously changing tensile loading of the belt means. In response to said squeezing, the interior of the tube portion is changed. The resulting displacement of the air in the tube portion can be detected by means of pressure measuring means or small volume flow sensors and used for generating the signals that are indicative of the tensile loading.

[0009] In accordance with a particularly preferable embodiment of the present invention, the buckle means is divided in two segments. These two segments can be config-

ured such that they alternately surround the tube portion and squeeze it under the influence of respective tensile forces acting on the individual segments.

[0010] It is possible to configure the walls which alternately surround the tube portion in such a manner with respect to their geometry that a favorable squeezing or relaxation of the tube portion is obtained under the influence of said tensile forces.

[0011] The change in the volume which is caused by loading the measuring space means in accordance with the present invention can advantageously be transferred via a measuring tube arrangement to a measuring means. In the area of this measuring means there is preferably a pressure-sensitive structure which converts the respiration-synchronously changing pressure in the measuring tube into suitable analog or digital signals.

[0012] Said measuring means can be configured such that a plurality of measuring tube means can be coupled thereto for realizing a corresponding multi-channel recording.

[0013] The above detecting means for detecting respiration-synchronously changing tensile forces in a belt system being passed around the torso region of the person to be examined can be configured such that particularly relevant respiration-motor or respiration-mechanic properties can be detected in an advantageous manner.

[0014] The present invention is further directed to a measuring arrangement which comprises a detecting means of the kind described above, wherein said measuring arrangement further comprises a measuring tube and a measuring means which is coupled via said measuring tube with the detecting means for recording the tensile force detection of the band means caused by the detecting means.

[0015] This measuring arrangement allows a potential-free signal measurement from the patient, thereby avoiding electrically conducting structures.

[0016] This measuring means is advantageously configured such that its signal recording capacity extends over a pressure signal range including also any pressure signals measured by nasal cannula means.

[0017] The measuring arrangement can comprise a storage medium, in particular an exchangeable storage medium, e.g., in the form of a memory card or in particular a USB flash stick. The measuring means preferably further comprises a receiving means for receiving a battery means for operating the measuring means independent from the network and/or in a wireless manner. The measuring means can be configured as an ambulant, compact module or recording means which can be carried by the patient and comprises a housing means having a flat configuration.

[0018] The detecting means of the present invention cannot only be used for diagnosing the respiratory behavior in a user, but it can also be integrated in a respiratory system if required, wherein the measuring signals generated by the detecting means can be taken into consideration in the further control of the respiratory gas supply. The detecting means of the present invention is particularly suitable for detecting the sleep respiration of a person to be examined. However, the field of application of said detecting means is not limited to the medical field. In particular, it can also be used in different applications for monitoring the respiratory motoricity, in particular for optimizing respiration.

[0019] The band means can be configured as a disposable band means so that for each patient to be examined a new band means can be used and coupled to the buckle means. It

is also possible to provide a tube-like disposable attachment or other hygiene cover, e.g., from a hygiene paper, by means of which the above detecting means or at least its band and buckle means can be covered. It is possible to configure the detecting means, in particular the buckle means, the band means and optionally also the measuring tube as a disposable unit which can be disposed of after the measurement.

[0020] It is possible to provide spring-type or other calibration possibilities which guarantee, on the one hand, a sufficient pre-stressing of the belt placed around the patient and, on the other hand, a sufficient ability to widen the thus formed loop. It is possible to realize the band material intended for forming the belt in a relatively tension-proof manner and to generate the required flexibility by structures, e.g., spring or rubber mechanisms, provided in the region of the buckle means. However, it proves to be particularly advantageous to select the band material such that it has a sufficient elasticity and the buckle means essentially only functions as a force measuring means.

[0021] Further details and features of the present invention can be taken from the following description in combination with the drawings in which

[0022] FIG. 1 is a principle view for explaining the structure of a preferred variant of the detecting means of the present invention,

[0023] FIG. 2 is a sketch for explaining the load and the resulting change in the volume of a tube portion,

[0024] FIG. 3 is a torso sketch showing the application of a detecting means of the present invention,

[0025] FIG. 4 is a further torso sketch illustrating a further way of guiding the band, optionally for a plurality of measuring channels, for an extended examination of the respiratory activity,

[0026] FIG. 5 is a further torso sketch further illustrating a further way of guiding the band for detecting the respiratory activity,

[0027] FIG. 6 is a simplified illustration for explaining a further variant of a measuring transducer of the present invention,

[0028] FIG. 7 is a sketch for explaining a plug-in sensor variant of the detecting means of the present invention,

[0029] FIG. 8 is a simplified illustration for explaining the structure of a measuring means for converting the recording of the respiration-synchronously alternating pressure signals generated by means of the detecting means of the present invention.

[0030] The detecting means shown in FIG. 1 serves for detecting a signal that is indicative of the activity of the respiratory muscles of a person to be examined. Said detecting means comprises a band means 1 which—in the application position (cf. FIG. 3)—is passed around a torso region which widens upon inspiration of the person to be examined and narrows accordingly upon expiration. The band means includes a structure being configured as a buckle means 2 and being loaded upon widening of the torso region by the tensile forces  $F_a$ ,  $F_b$  accordingly acting in the band means 1. Said structure is configured such that it causes a change in the volume of a measuring space means 3.

[0031] In the shown embodiment the structure is a buckle means 2, as already mentioned. The change in the volume of the measuring space means 3 is caused by squeezing elastically deformable walls of the measuring space means 3. In the shown embodiment, the elastically deformable walls form an elastic chamber means which as such is realized by a tube

portion 4. The ends of the tube portion 4 are closed by an insert 5. The tube portion 4 is surrounded by eyelet portions 6, 7 alternately belonging to a left segment 2a and a right segment 2b.

[0032] The shown mechanism allows a squeezing of the tube portion 4 in accordance with the tensile forces  $F_a$ ,  $F_b$  acting on the belt means 1. By squeezing the tube portions 4, the volume of the measuring space means 3 formed by the tube portion 4 changes. Due to the change in the volume, the included air is displaced, in particular moved out. This air displacement can be detected in particular if the measuring tube 8 is closed to a large extent by a measuring means which will be explained in detail below. It is possible to provide a bypass throttle bore 9 in the measuring tube 8 or in particular in the plug or connector 5 or also in the region of the measuring means. By means of this throttle bore it is possible to realize a high-pass filter which guarantees that the average pressure in the measuring tube means 8 corresponds for a long time to the ambient pressure and no deviation takes place.

[0033] FIG. 2 is a sketch showing how the tube portion 4 of the measuring tube 8 is loaded by the forces  $F_A$ ,  $F_B$  coupled in via the segments 2a, 2b. Due to the shown loads, the tube portion 4 of the measuring tube 8 deforms from the initial state having an inner cross-section A1 as shown in sketch S1 into the squeezed deformed state shown in sketch S2. In this deformed state the tube portion 4 has an inner cross-section A2 being smaller than the inner cross-section A1 shown in sketch S1.

[0034] It is possible to configure the eyelets or squeezing structures surrounding the tube portion 4 in such a manner as regards their geometry that they favor or at least do not considerably hinder the deformation of the tube portion 4. To this end, the eyelet portions preferably have an opening cross-section which is larger than the outer cross-section of the measuring tube portion 4.

[0035] As shown in FIG. 3, the detecting means of the present invention is particularly suitable for detecting the widening and narrowing of the torso 10 of a person to be examined. The band means 1 is passed around the torso 10. The band means 1 includes the structure which, in the present case, is configured as a buckle means 2. The tensile forces acting on the band means 1 as the torso 10 widens are detected by the squeezing of a measuring space means 3 caused by the buckle means 2 (cf. FIG. 1).

[0036] FIG. 4 shows a further way of guiding the band. On the basis of the tensile force measuring principle of the detecting means of the present invention it is possible to realize a multi-channel measuring system by means of which respiration-motor properties of the respiration of the patient to be examined can be recorded in a multi-channel manner. For example, it is possible to detect, in addition to an elongation of the lower band means 1', also an elongation or widening of the upper band means 2a, 2b shown in FIG. 4.

[0037] FIG. 5 shows a further way of guiding the band. In accordance with this variant it is possible to detect, in addition to a widening of the upper portion of the torso 10 by the upper band means 1', also movements of the respiration muscles in the area of the diaphragm by means of a band means 1c that is arranged further below and extends over the lower lung area. In this variant, too, it is possible to additionally record tensile forces in the band regions 2a and 2b in a multi-channel manner by accordingly coupling them in a detecting means of the present invention.

**[0038]** FIG. 6 shows a further variant of a pneumatic measuring transducer of the present invention. In this variant, the respiration-synchronously alternating tensile forces  $F_a$ ,  $F_b$  prevailing in the band means **1** cause a change in the volume of the measuring space means **3**. In this embodiment, too, the measuring space means **3** is included in a bracket means **2** comprising left and right bracket portions  $2a'$ ,  $2b'$ . In this embodiment, the measuring space means is also configured as an elastically deformable structure and comprises a portion which can be accordingly widened in response to the tensile forces acting on the band means **1**. In this embodiment, this portion is realized as a corrugated sheathing portion **20**. A spring means **21**, by means of which a specific pre-loading of the detecting means is achieved, is embedded in the corrugated sheathing portion **20**. It is possible to realize said spring means **21** as part of a calibration system. Via a measuring tube means **8**, the change in the pressure and/or volume in the area of the measuring space means **3** can be detected via corresponding connection channels **22** and supplied to a corresponding measuring means. Different from the squeezing variant, in this mechanism the measuring chamber volume is increased as the band widens (inspiration) and thus a measuring signal is obtained which is reversed relative to the measuring signal of the squeezing variant.

**[0039]** FIG. 7 shows a variant of the measuring space means **3** which as such comprises an elastically deformable tube portion **4**, similar to the above description relating to FIG. 1. Deformation of this tube portion **4** directly leads to pressure changes in the interior of the measuring space means **3**. Said pressure changes can be detected by a miniaturized measuring transducer means **25** and transmitted to a detachably coupled storage means **26**, in the present case a USB flash stick. The shown means can comprise an energy storage means, e.g., in the form of a button cell battery. It is also possible to realize the measuring transducer circuit such that the energy required for generating and recording signals is provided directly by the pressure sensor.

**[0040]** FIG. 8 shows a measuring means provided for converting and recording signals generated by means of the detecting means described above. Said measuring means **30** is configured as a multi-channel measuring means. An end portion of the measuring tube **8** can be coupled (e.g. inserted into a receiving bore or put on a measuring connection) to said measuring means **30**. The pressure changes coupled in the measuring tube **8** during the respiration-synchronous squeezing of the tube portion **4** (cf. FIG. 1) can be recorded by the shown measuring means and preferably stored in digital form.

**[0041]** The measuring means **30** is configured such that it can be activated by a switch means **31**. The pressure fluctuations passed by the measuring tube **8** to the measuring means **30** can be recorded in accordance with different recording concepts which are preferably stored in the measuring means **30** in a program-based manner. Recording can preferably take place in such a manner that the course of the individual breaths of the person to be examined can be determined with a relatively high resolution (high-resolution raw data recording). It is possible to use the shown measuring means **30** in addition to the conventional recording of the respiration of the patient for diagnosis purposes also for further controlling the respiration of the patient by pressure.

**[0042]** It is possible to configure the measuring means **30** such that it is also possible to record signals that are indicative of the nasal or oral respiratory gas flow of a person to be

examined. In the shown variant, the measuring means **30** comprises further connection portions **40**, **41** via which also pressure signals can be coupled for the purpose of further recording which can be measured, e.g., by a nasal cannula means or other detecting means for detecting the respiratory gas flow from the patient to be examined.

**[0043]** In accordance with a further aspect of the present invention, the detecting means also comprises a measuring channel for generating a recording signal that is indicative of the oxygen saturation of the blood. To this end, the detecting means **30** can be configured such that it can be connected to a light guide means **60** for introducing light measured at the patient, e.g., in the area of the nose wings or the extremities, in particular fingers. The light guide can have a plurality of conductors so that the light directed to the patient for the purpose of examination can be generated in the area of the measuring means and guided to the patient via the additional light guide, if required. The reflected light measured at the patient can be returned via the second light guide. Tissue portions with good blood supply, in particular finger tips, the area surrounding the ear and nasal areas, are particularly suitable as measuring positions. The light guides can be attached to these portions by means of suitable application structures. It is possible to provide the light guides with a relatively small coupling head which can otherwise be fixed to the patient by means of an adhesive tape or any other adhesive bandage material.

**[0044]** In the shown measuring means it is possible to measure numerous polysomnographic measuring parameters of a patient in a completely non-electric manner and without use of electrically conductive structures. It is possible to integrate the light guide means **60** in the measuring tube **8** and/or manufacture the measuring tube **8** from a material which is directly suitable as a light guide. The measuring means can also comprise further recording systems and channels, in particular for ECG, EEG or other body-electric potential signals.

What is claimed is:

1. A detecting arrangement for detecting a signal that is indicative of activity of the respiratory muscles of a person to be examined, the detecting arrangement comprising:

a band that is configured to be passed around a torso region that widens and narrows in response to the respiration of the person to be examined;

a structure that is included in the band and that is loaded by the band in accordance with the narrowing and widening of the torso region; and

a measuring space device including a bypass throttle bore, wherein the structure is configured such that the measuring space decreases the volume of the measuring space device when the person inhales.

2. The detecting arrangement according to claim 1, wherein the measuring space device comprises an elastically deformable chamber.

3. The detecting arrangement according to claim 2, wherein the elastic chamber includes a tube portion.

4. The detecting arrangement according to claim 3, wherein the bypass throttle bore is in the tube portion.

5. The detecting arrangement according to claim 4, wherein the tube portion is squeezed in accordance with tensile loading of the band.

6. The detecting arrangement according to claim 4, wherein the structure is divided into two segments, and the

two segments surround the tube portion for squeezing it depending on the tensile force.

7. The detecting arrangement according to claim 4, wherein walls surrounding the tube portion have a geometry such that deformation conditions are obtained depending on the tensile force created by squeezing of the tube portion.

8. The detecting arrangement according to claim 1, wherein the detecting arrangement forms part of a multi-channel measuring system.

9. The detecting arrangement according to claim 1, wherein a change in the volume depending on the tensile force applied to the band is passed on to a measuring device via a measuring tube arrangement.

10. The detecting arrangement according to claim 9, wherein the bypass throttle bore is proximate to the measuring device.

11. The detecting arrangement according to claim 9, wherein the measuring device comprises a signal recorder.

12. The detecting arrangement according to claim 9, wherein the bypass throttle bore is configured to maintain a substantially constant average pressure in the measuring tube arrangement.

13. A measuring arrangement comprising a detecting arrangement according to claim 1, the measuring arrangement further comprising a measuring tube and a measuring device coupled to the detecting arrangement via the measuring tube for recording tensile force measuring signals measured by the detecting arrangement.

14. The measuring arrangement according to claim 13, wherein the measuring device is configured such that a signal recording capacity thereof extends over a pressure signal range that also comprises the dynamic pressure signals that can be measured via a nasal cannula detecting the respiratory gas flow from the patient.

15. The detecting arrangement according to claim 1, wherein the structure at least partially surrounds the measuring space device.

16. The detecting arrangement according to claim 1, wherein the bypass throttle bore is located adjacent to the structure.

\* \* \* \* \*

专利名称(译)	呼吸检测装置		
公开(公告)号	<a href="#">US20140081166A1</a>	公开(公告)日	2014-03-20
申请号	US14/082532	申请日	2013-11-18
[标]申请(专利权)人(译)	瑞思迈研究与开发德国有限公司		
申请(专利权)人(译)	瑞思迈研发德国公司		
当前申请(专利权)人(译)	瑞思迈研发德国公司		
[标]发明人	LANG BERND CHRISTOPH SCHATZL STEFAN		
发明人	LANG, BERND CHRISTOPH SCHATZL, STEFAN		
IPC分类号	A61B5/113 A61B5/11 A61B5/00		
CPC分类号	A61B5/1135 A61B5/1118 A61B5/6831 A61B5/6823 A61B2562/168		
优先权	PCT/EP2006/003754 2006-04-24 WO 102005020162 2005-04-29 DE		
其他公开文献	US9066684		
外部链接	<a href="#">Espacenet</a> <a href="#">USPTO</a>		

摘要(译)

本申请涉及一种检测器，用于检测或产生指示人的呼吸的测量信号，其中所述检测器可有利地用于卫生并且由于简单且坚固的配置而突出。根据第一方面，检测器检测指示待检查人的呼吸肌活动的信号，该检测器包括在应用位置绕过躯干区域的带，该躯干区域变宽和变窄。当待检查的人呼吸时，以及包括在带中并根据躯干区域的变窄或变宽加载的结构。该结构被配置成使得其根据张力引起测量空间装置的体积变化。因此有利地可以以非电方式检测或测量作用在带上的力，并且基于该检测或测量，得出与躯干的加宽或变窄有关的结论。

