



US010368765B2

(12) **United States Patent**  
**Huang et al.**

(10) **Patent No.:** **US 10,368,765 B2**  
(45) **Date of Patent:** **Aug. 6, 2019**

(54) **WEARABLE APPARATUS FOR ECG SIGNAL ACQUISITION**

(71) Applicants: **Anhui Huami Information Technology Co., Ltd.**, Hefei, Anhui (CN); **Huami Inc.**, Mountain View, CA (US)

(72) Inventors: **Wang Huang**, Hefei (CN); **Jixiang Su**, Hefei (CN); **Yajun Zhao**, Anhui (CN); **Fei Wang**, Mountain View, CA (US); **Yuanxiang Wang**, Mountain View, CA (US)

(73) Assignees: **Anhui Huami Information Technology Co., Ltd.**, Hefei (CN); **Huami Inc.**, Mountain View, CA (US)

(\* ) Notice: Subject to any disclaimer, the term of this patent is extended or adjusted under 35 U.S.C. 154(b) by 95 days.

(21) Appl. No.: **15/613,755**

(22) Filed: **Jun. 5, 2017**

(65) **Prior Publication Data**  
US 2017/0273584 A1 Sep. 28, 2017

**Related U.S. Application Data**

(63) Continuation-in-part of application No. 15/233,103, filed on Aug. 10, 2016, and a continuation-in-part of (Continued)

(30) **Foreign Application Priority Data**

Feb. 2, 2016 (CN) ..... 2016 1 0079901

(51) **Int. Cl.**  
**A61B 5/0404** (2006.01)  
**A61B 5/0416** (2006.01)  
(Continued)

(52) **U.S. Cl.**  
CPC ..... **A61B 5/0404** (2013.01); **A61B 5/0416** (2013.01); **A61B 5/0452** (2013.01);  
(Continued)

(58) **Field of Classification Search**  
CPC ..... **A61B 5/04**; **A61B 5/0402**; **A61B 5/0404**; **A61B 5/04085**; **A61B 5/0416**;  
(Continued)

(56) **References Cited**

**U.S. PATENT DOCUMENTS**

5,226,425 A 7/1993 Righter  
5,738,104 A 4/1998 Lo et al.  
(Continued)

**FOREIGN PATENT DOCUMENTS**

CN 101547635 A 9/2009  
CN 101969840 A 2/2011  
(Continued)

*Primary Examiner* — Christopher A Flory

(74) *Attorney, Agent, or Firm* — Young Basile Hanlon & MacFarlane, P.C.

(57) **ABSTRACT**

Methods, apparatuses and wearable devices for measuring an ECG signal for a user wearing a wearable device includes when the ECG signal is measured in a first mode, receiving the ECG signal by an ECG sensor from a closed circuit formed by a first ECG sensor electrode and a second ECG sensor electrode, in which the wearable device includes a main body detachable to the wearable device, a connecting portion, and electrode patches, and the main body includes the ECG sensor, the first ECG sensor electrode, and the second ECG sensor electrode, and when the ECG signal is measured in a second mode, receiving the ECG signal by the ECG sensor from a closed circuit formed by electrodes of the electrode patches, in which the ECG sensor is in the main body and the main body is connected to the electrode patches.

**17 Claims, 12 Drawing Sheets**

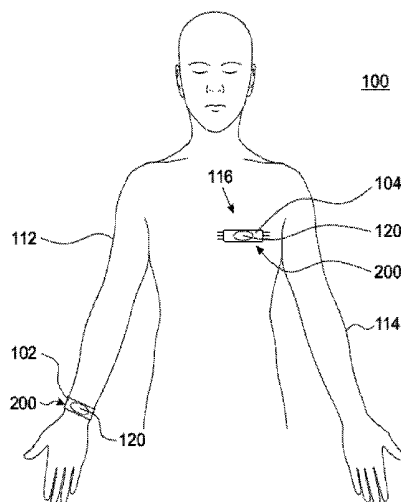

**Related U.S. Application Data**

application No. PCT/CN2017/071478, filed on Jan. 18, 2017.

(51) **Int. Cl.**

- A61B 5/0408* (2006.01)
- A61B 5/0432* (2006.01)
- A61B 5/0468* (2006.01)
- A61B 5/0452* (2006.01)
- A61B 5/00* (2006.01)
- A61B 5/0402* (2006.01)
- A61B 5/11* (2006.01)

(52) **U.S. Cl.**

- CPC ..... *A61B 5/0468* (2013.01); *A61B 5/04085* (2013.01); *A61B 5/04087* (2013.01); *A61B 5/04325* (2013.01); *A61B 5/7267* (2013.01); *A61B 5/0402* (2013.01); *A61B 5/1123* (2013.01); *A61B 5/6824* (2013.01); *A61B 5/6831* (2013.01); *A61B 5/6833* (2013.01)

(58) **Field of Classification Search**

- CPC . *A61B 5/04325*; *A61B 5/0452*; *A61B 5/0468*; *A61B 5/1123*; *A61B 5/4267*; *A61B 5/6824*; *A61B 5/6831*; *A61B 5/6833*
- USPC ..... 600/509
- See application file for complete search history.

(56) **References Cited**

U.S. PATENT DOCUMENTS

8,688,189	B2	4/2014	Shennib	
8,738,118	B2*	5/2014	Moon	A61B 5/0002 600/513
10,055,549	B2*	8/2018	Chung	G16H 50/30
2006/0264767	A1	11/2006	Shennib	
2007/0032733	A1*	2/2007	Burton	A61B 5/02405 600/509
2007/0276261	A1*	11/2007	Banet	A61B 5/02255 600/481
2007/0276262	A1*	11/2007	Banet	A61B 5/02255 600/485
2007/0279217	A1	12/2007	Venkatraman et al.	
2008/0021336	A1	1/2008	Dobak	
2009/0270747	A1	10/2009	van Dam et al.	
2009/0292194	A1*	11/2009	Libbus	A61B 5/0002 600/391
2010/0063365	A1	3/2010	Pisani et al.	
2010/0113950	A1	5/2010	Lin et al.	
2010/0174205	A1	7/2010	Wegerif	
2010/0268056	A1*	10/2010	Picard	A61B 5/0531 600/388
2012/0029314	A1*	2/2012	Paquet	A61B 5/02055 600/301
2013/0053674	A1*	2/2013	Volker	A61B 5/04085 600/389
2013/0069780	A1*	3/2013	Tran	A61B 5/0024 340/539.12
2013/0072807	A1*	3/2013	Tran	A61B 5/02405 600/485
2013/0151699	A1*	6/2013	Vock	A43B 3/0005 709/224
2013/0171599	A1	7/2013	Bleich et al.	

2013/0178718	A1*	7/2013	Tran	A61B 5/0024 600/301
2013/0178728	A1	7/2013	Vandermeiden et al.	
2013/0231947	A1*	9/2013	Shusterman	G06F 19/3418 705/2
2013/0237772	A1	9/2013	Pisani et al.	
2013/0281795	A1	10/2013	Varadan	
2014/0125618	A1*	5/2014	Panther	A61B 5/6838 345/173
2014/0135636	A1	5/2014	Kang et al.	
2014/0187974	A1*	7/2014	Banet	A61B 5/6822 600/483
2014/0188257	A1	7/2014	Ura et al.	
2014/0228665	A1	8/2014	Albert	
2014/0275852	A1	9/2014	Hong et al.	
2014/0288392	A1	9/2014	Hong et al.	
2014/0288449	A1	9/2014	Wegerif	
2015/0018660	A1*	1/2015	Thomson	A61B 5/0404 600/393
2015/0073285	A1	3/2015	Albert et al.	
2015/0250396	A1*	9/2015	Ahmed	A61B 5/02405 600/508
2015/0265214	A1	9/2015	De Kok et al.	
2015/0265217	A1	9/2015	Penders et al.	
2015/0272515	A1*	10/2015	Paquet	A61B 5/02055 600/301
2015/0279187	A1	10/2015	Kranz	
2015/0282767	A1*	10/2015	Stivoric	A61B 5/01 600/301
2015/0287338	A1*	10/2015	Wells	G09B 19/0038 702/19
2015/0289814	A1*	10/2015	Magar	A61B 5/0205 600/301
2015/0297134	A1*	10/2015	Albert	A61B 5/681 600/384
2015/0302150	A1*	10/2015	Mazar	G08B 21/0211 705/2
2015/0302538	A1*	10/2015	Mazar	G08B 21/0211 705/2
2015/0302539	A1*	10/2015	Mazar	G08B 21/0211 705/3
2015/0313476	A1	11/2015	Pisani et al.	
2015/0370320	A1*	12/2015	Connor	A61B 5/6831 345/173
2016/0021535	A1	1/2016	Tali et al.	
2016/0157779	A1	6/2016	Baxi et al.	
2016/0183869	A1*	6/2016	Oh	A61B 5/7475 600/595
2016/0192856	A1	7/2016	Lee	
2016/0192857	A1	7/2016	Lee	
2016/0287166	A1*	10/2016	Tran	H04B 1/3827
2016/0331234	A1	11/2016	Kang et al.	
2016/0331257	A1*	11/2016	Baumann	A61B 5/6833
2016/0338640	A1	11/2016	Chan et al.	
2016/0352727	A1	12/2016	Day et al.	
2017/0049336	A1	2/2017	Hatch	
2017/0049338	A1	2/2017	Pisani et al.	
2017/0055905	A1*	3/2017	Cohrs	A61B 5/6831
2017/0087371	A1*	3/2017	Freeman	A61N 1/3987
2018/0020980	A1	1/2018	Marcus et al.	

FOREIGN PATENT DOCUMENTS

CN	104055499	A	9/2014
CN	104665823	A	6/2015
CN	105615870	A	6/2016

\* cited by examiner

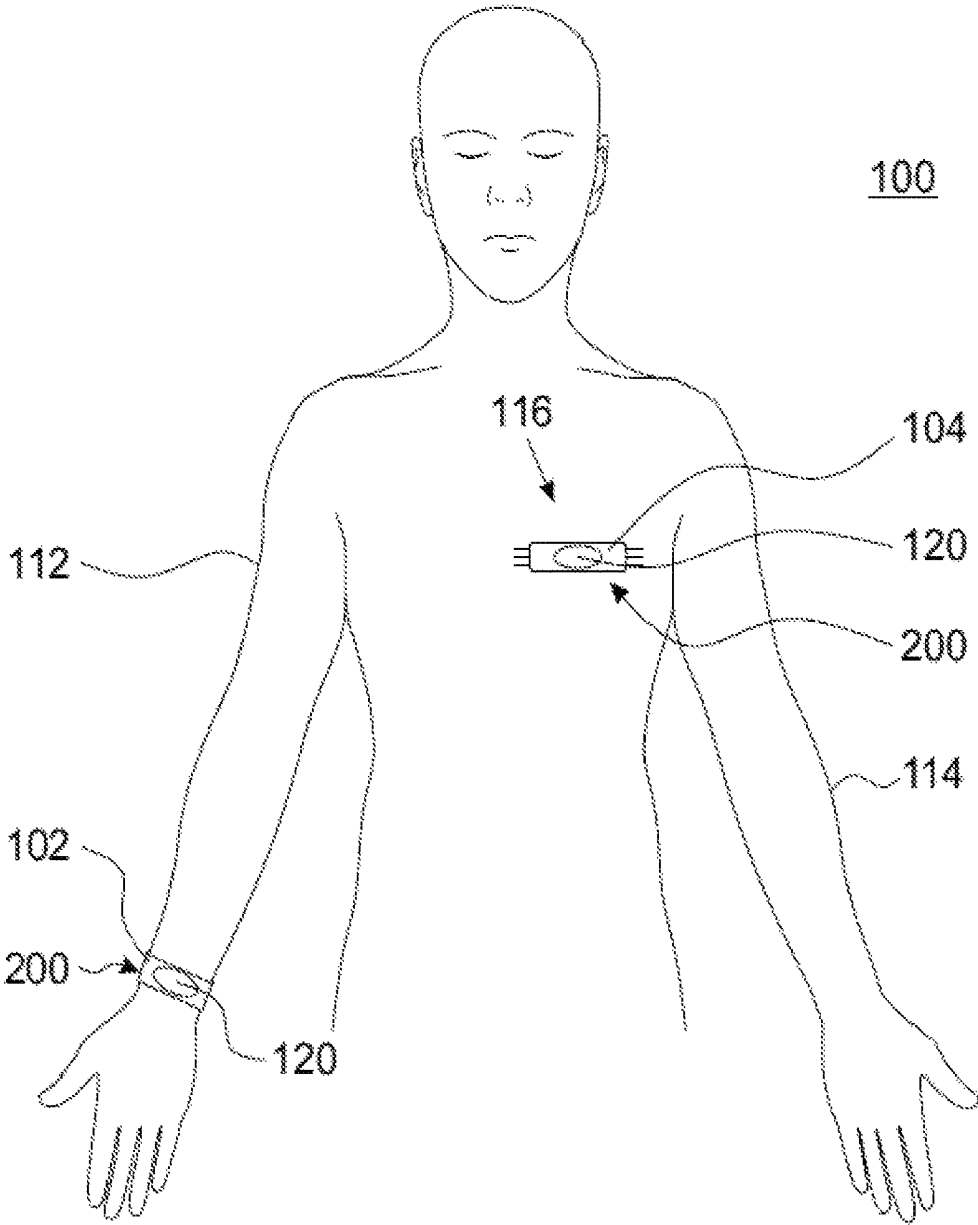

FIG. 1A

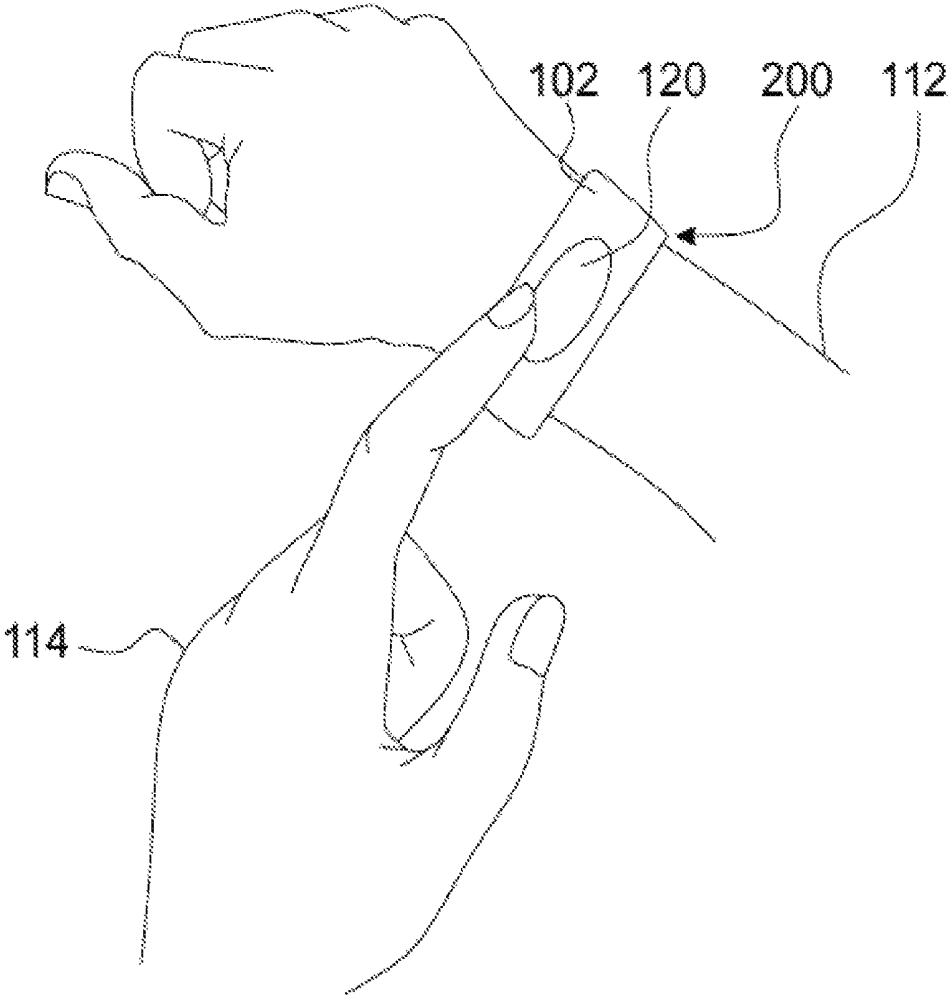

FIG. 1B

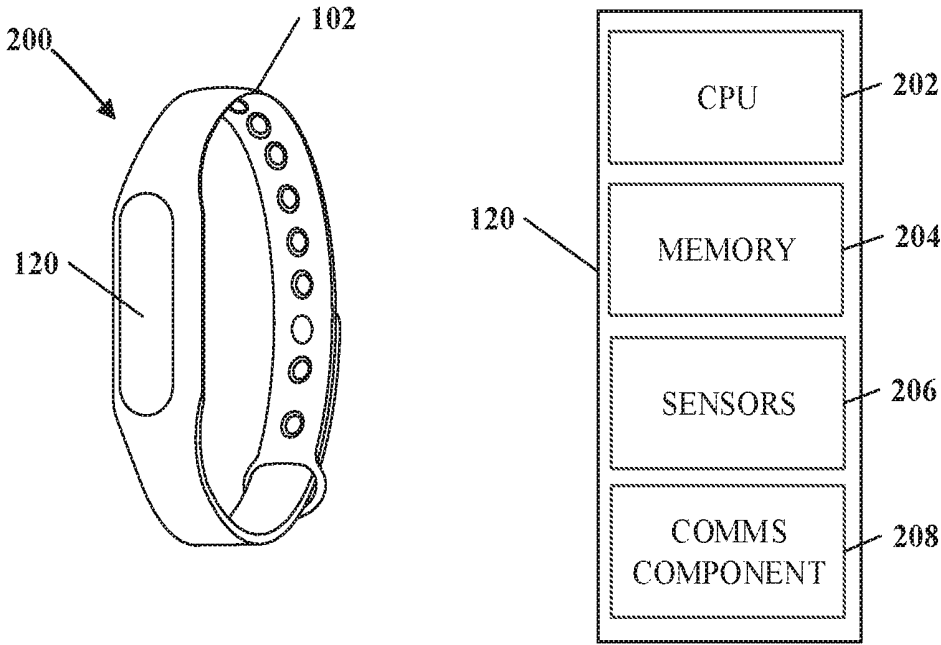

FIG. 2

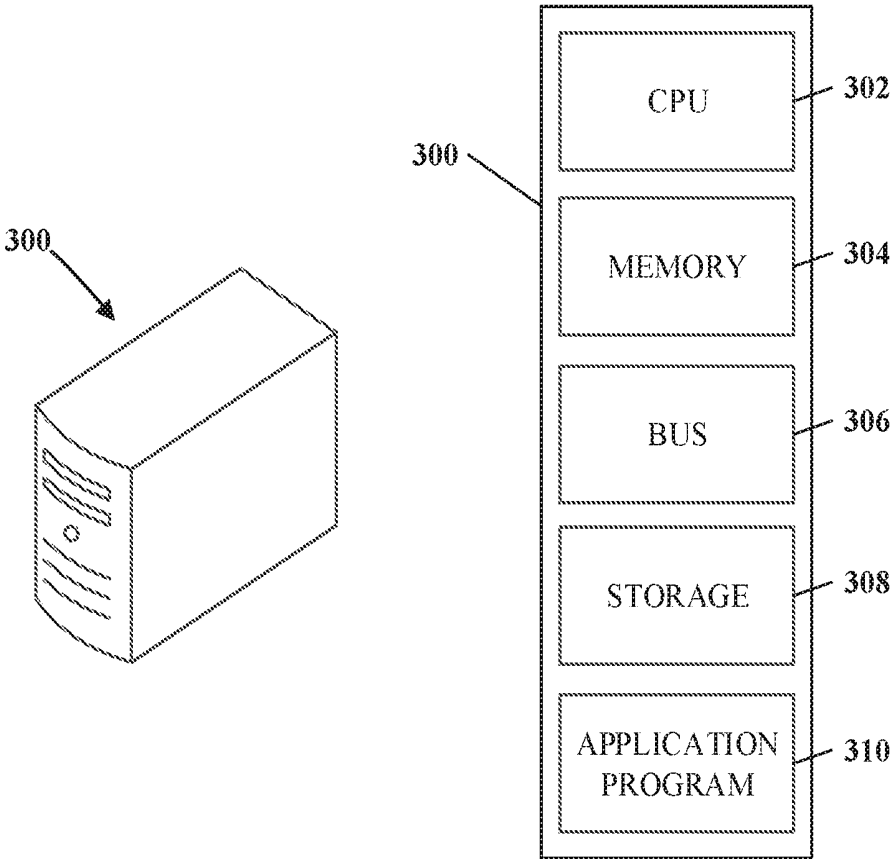

FIG. 3

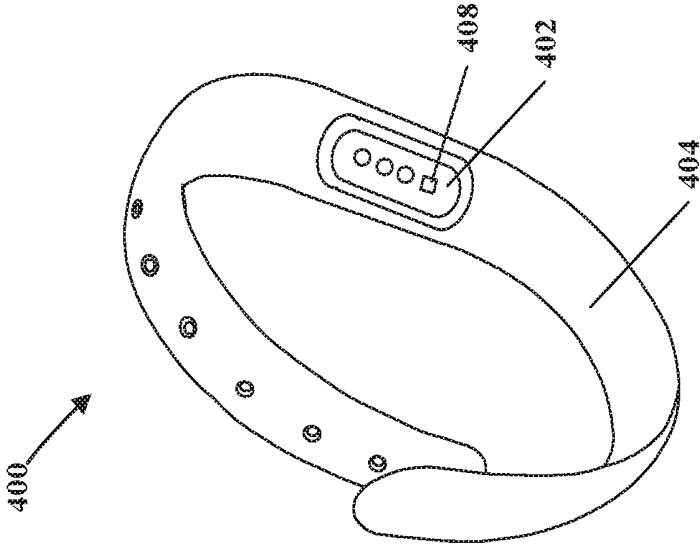

FIG. 4B

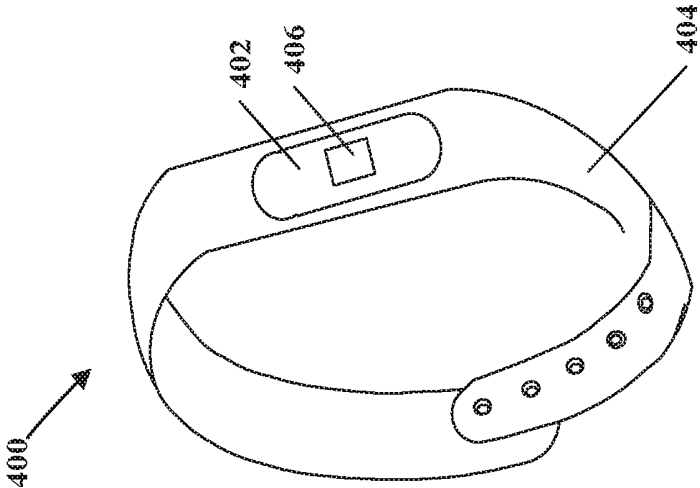

FIG. 4A

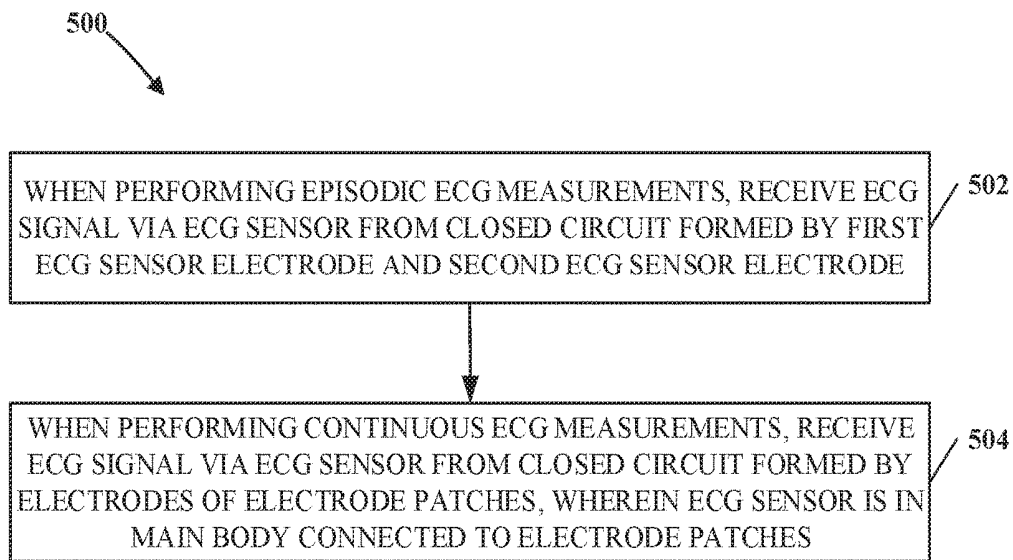

FIG. 5

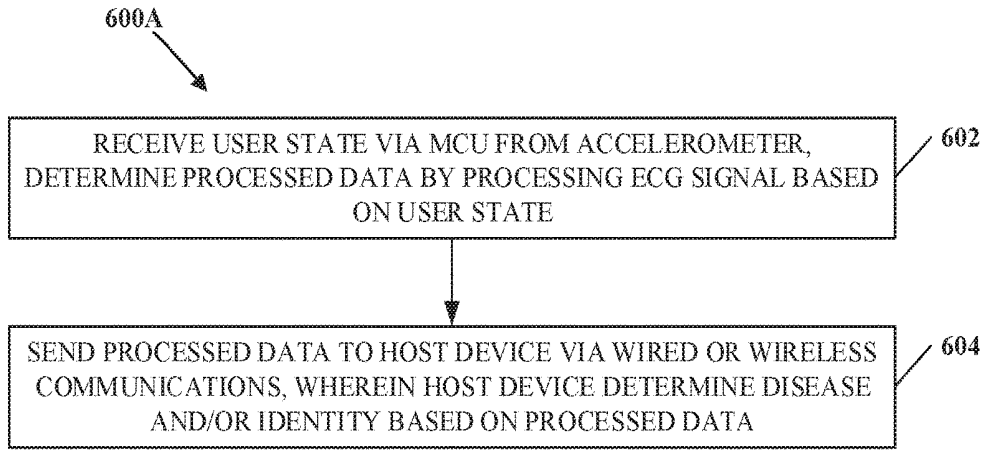

FIG. 6A

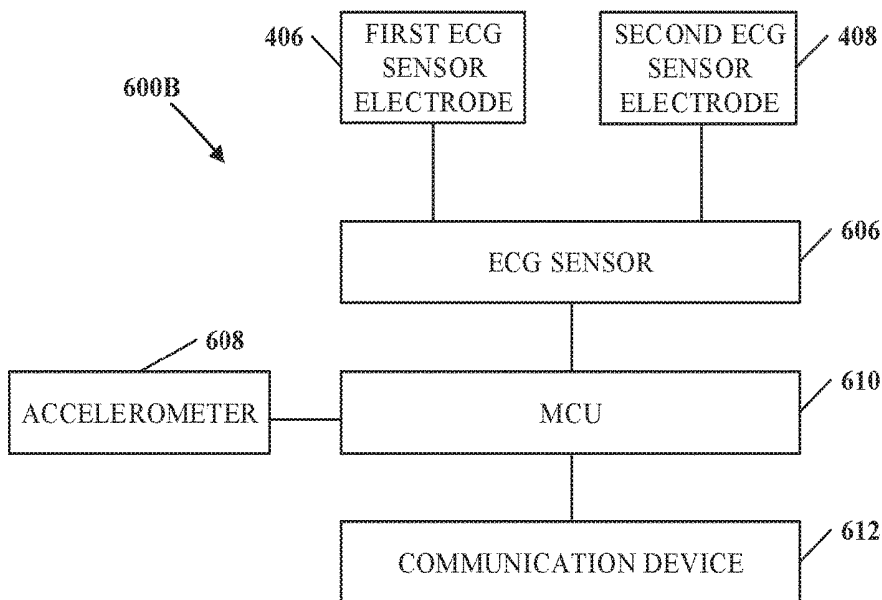

FIG. 6B

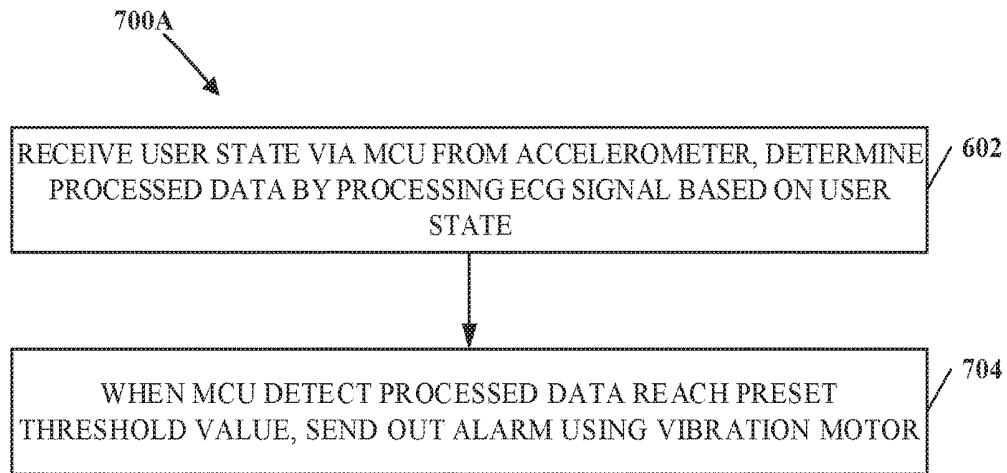

FIG. 7A

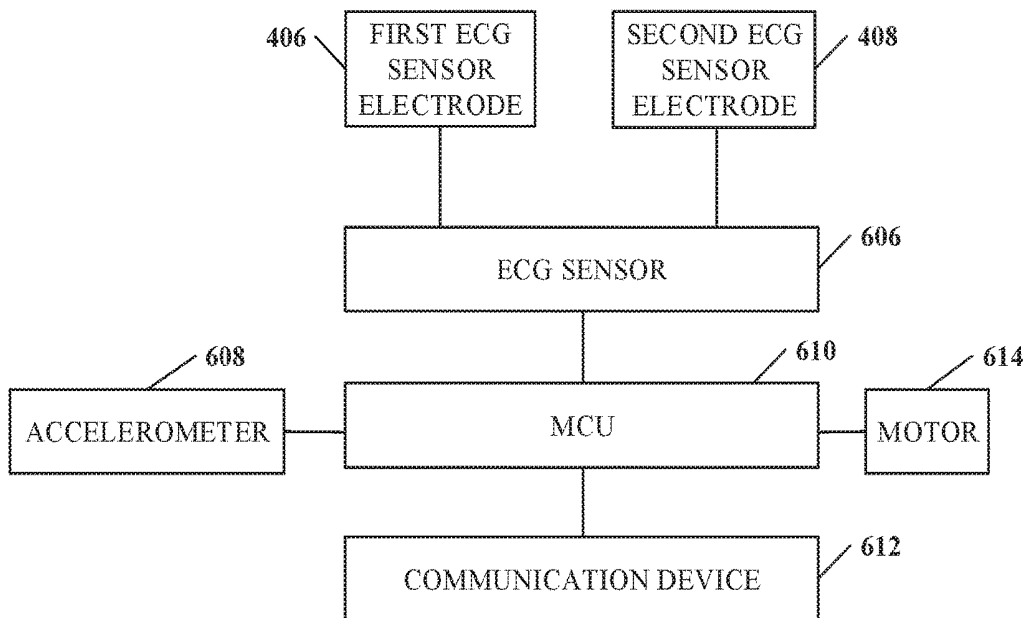

FIG. 7B

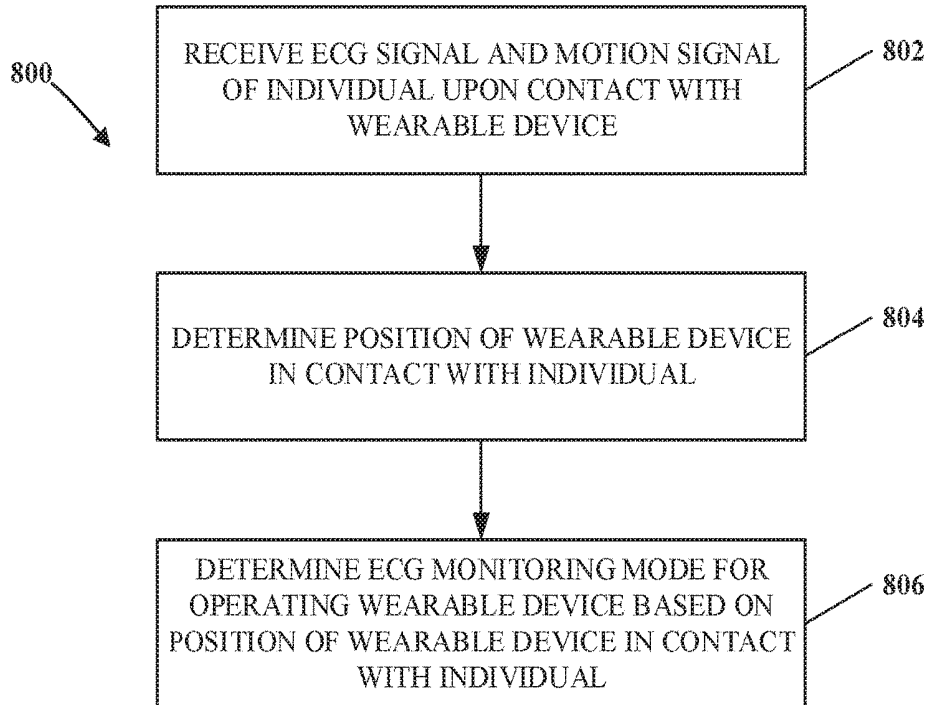

FIG. 8

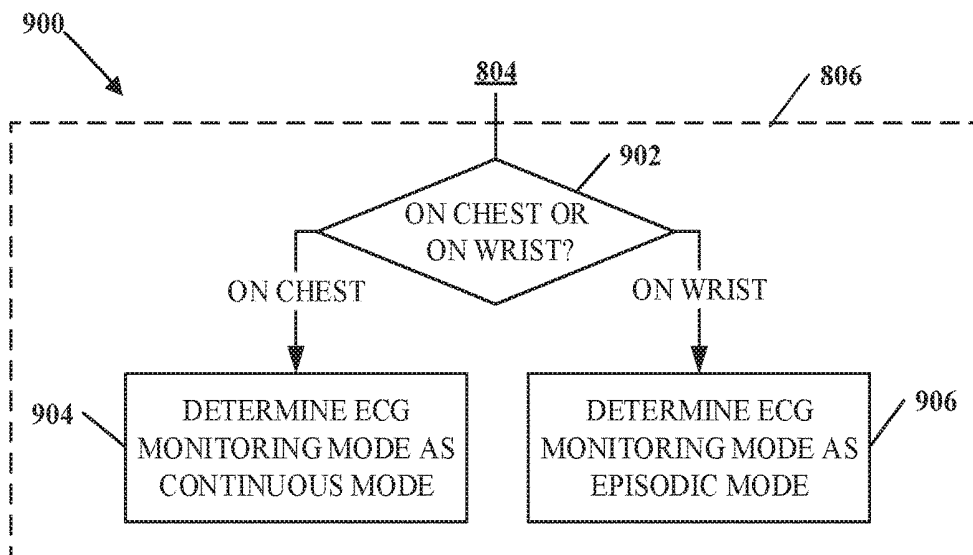

FIG. 9

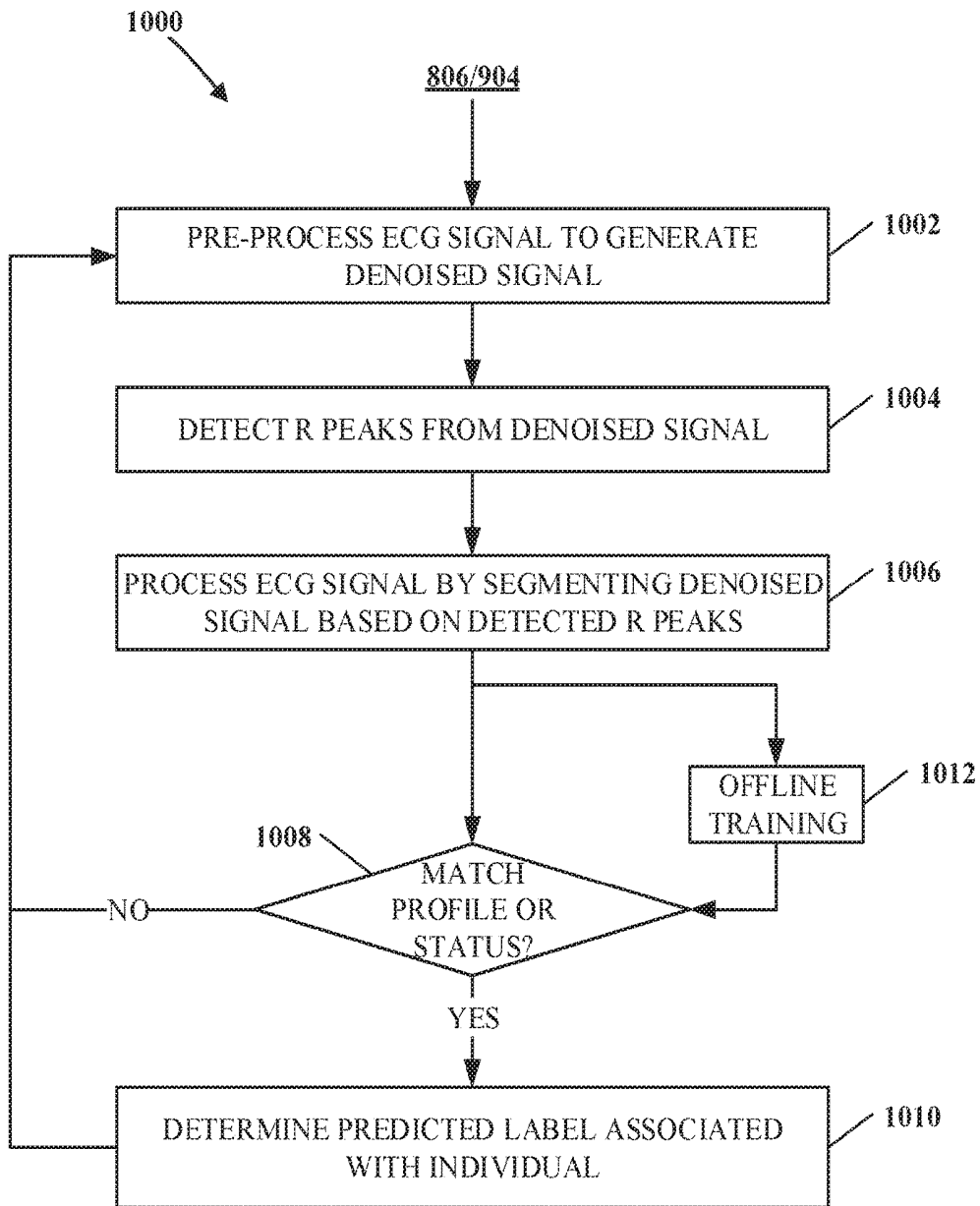

FIG. 10

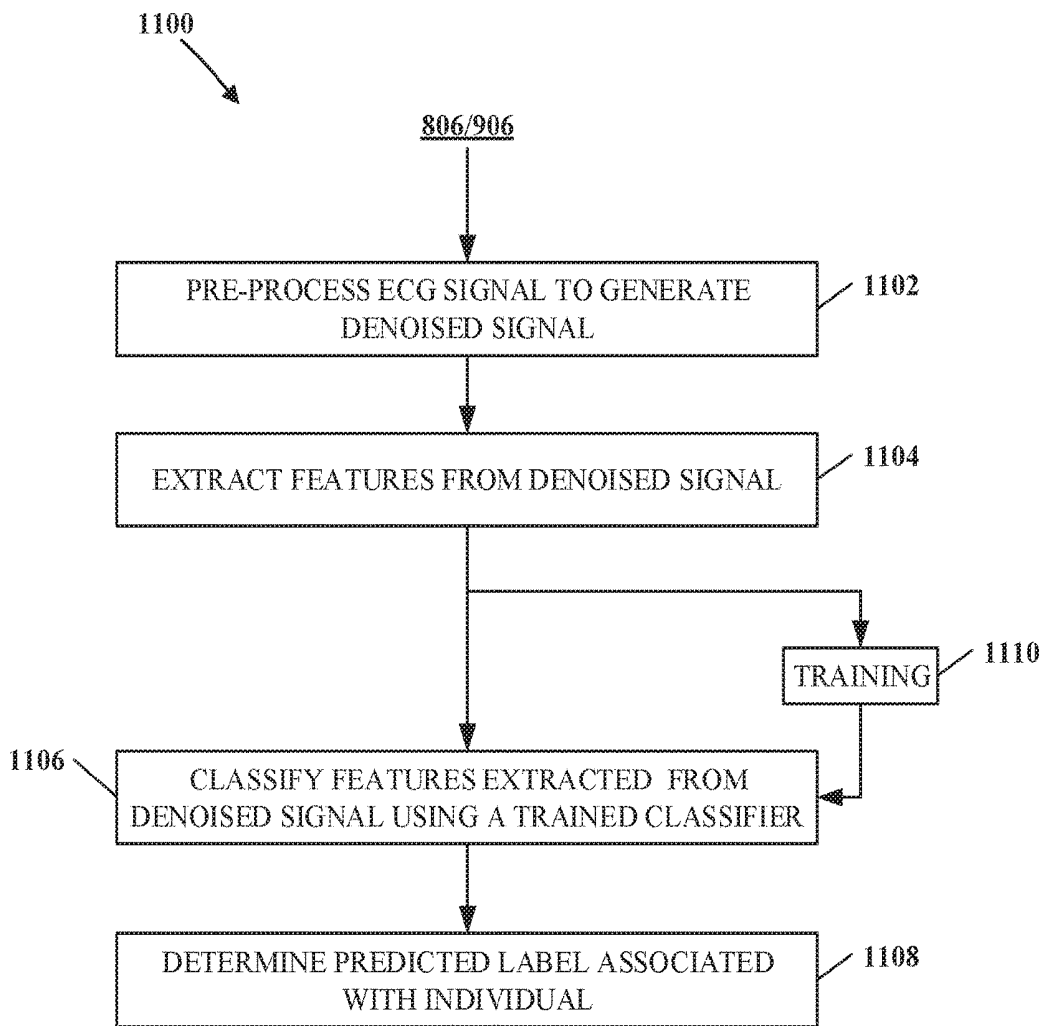

FIG. 11

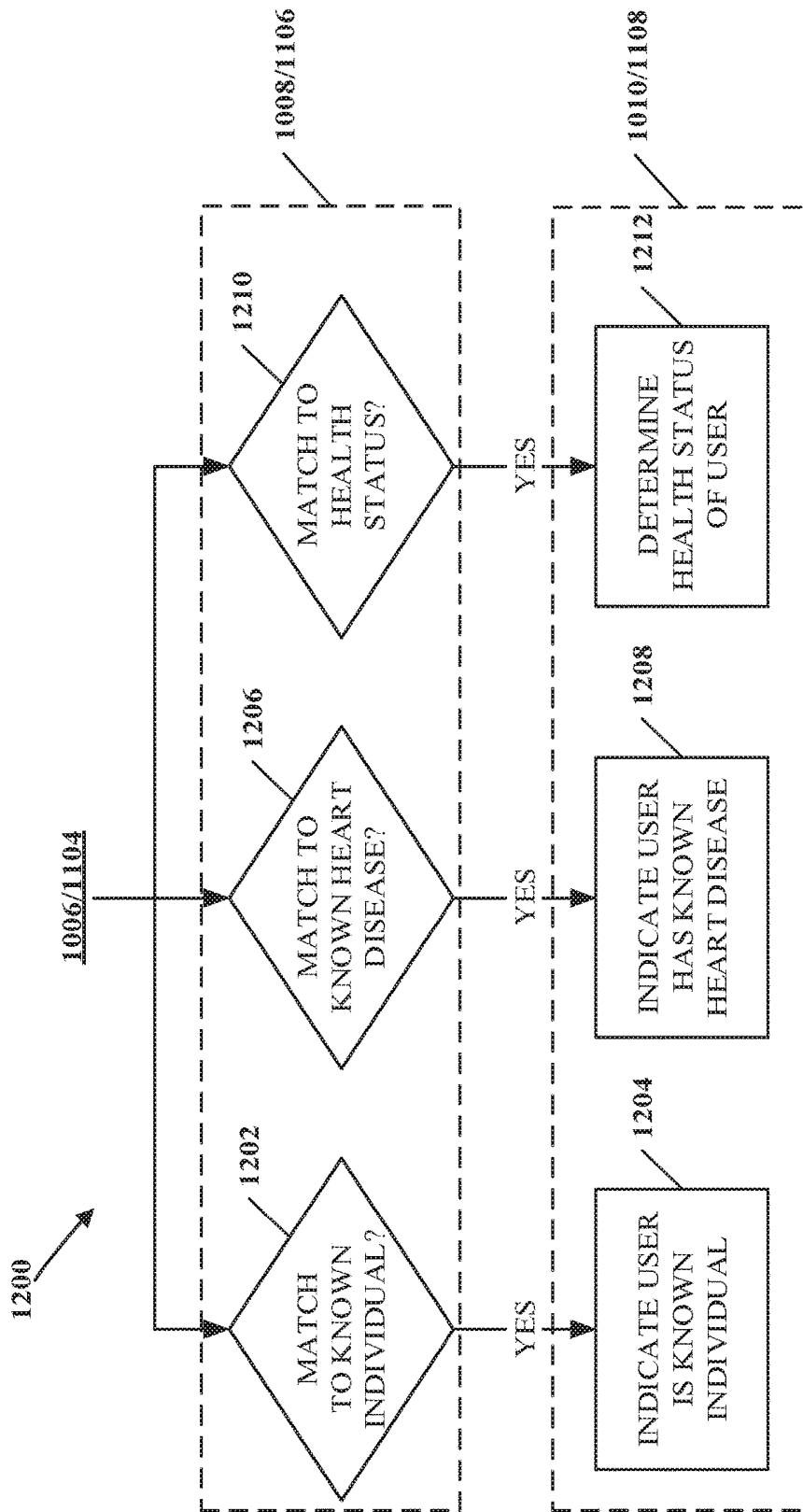

FIG. 12

## WEARABLE APPARATUS FOR ECG SIGNAL ACQUISITION

### CROSS-REFERENCE TO RELATED APPLICATION(S)

This application is a continuation-in-part of U.S. application patent Ser. No. 15/233,103, filed Aug. 10, 2016, and a continuation-in-part of International Patent Application PCT No. PCT/CN2017/071478, filed on Jan. 18, 2017, which claims priority to Chinese Application No. 201610079901.3, filed Feb. 2, 2016, the entire disclosure of all of which are hereby incorporated by reference in their entireties.

### TECHNICAL FIELD

This disclosure relates in general to heart activity monitoring, and in particular, Electrocardiography (ECG) monitoring.

### BACKGROUND

Wearable devices are becoming increasingly commonplace. They may be used in a variety of contexts, such as to monitor the health of a user by measuring vital signals, track a user's exercise and fitness progress, check a user's emails or social media accounts, etc. In certain applications, wearable devices may be configured to measure and monitor signals indicative of electrical activities of the user's heart, such as ECG signals, for detection of certain heart related diseases.

### SUMMARY

The present disclosure provides implementations of methods, apparatuses and wearable devices for measuring an electrocardiograph (ECG) signal for a user wearing a wearable device.

According to one aspect of the disclosure, the method includes when the ECG signal is measured in a first mode, receiving the ECG signal by an ECG sensor from a closed circuit formed by a first ECG sensor electrode and a second ECG sensor electrode, wherein the wearable device comprises a main body detachable to the wearable device, a connecting portion, and electrode patches, and the main body comprises the ECG sensor, the first ECG sensor electrode, and the second ECG sensor electrode, and when the ECG signal is measured in a second mode, receiving the ECG signal by the ECG sensor from a closed circuit formed by electrodes of the electrode patches, wherein the ECG sensor is in the main body and the main body is connected to the electrode patches.

In another aspect, the apparatus includes a processor and a memory. The memory is configured to store instructions which when executed by the processor become operational with the processor to, when the ECG signal is measured in a first mode, receive the ECG signal by an ECG sensor from a closed circuit formed by a first ECG sensor electrode and a second ECG sensor electrode, wherein the wearable device comprises a main body detachable to the wearable device, a connecting portion, and electrode patches, and the main body comprises the ECG sensor, the first ECG sensor electrode, and the second ECG sensor electrode, and when the ECG signal is measured in a second mode, receive the ECG signal by the ECG sensor from a closed circuit formed

by electrodes of the electrode patches, wherein the ECG sensor is in the main body and the main body is connected to the electrode patches.

In another aspect, the wearable device includes a main body detachable from the wearable device, comprising a first ECG sensor electrode provided on an inner surface of the main body, a second ECG sensor electrode provided on an outer surface of the main body, and an ECG sensor, a securing portion comprising a wrist band, and at least two electrode patches, detached from the main body and the securing portion, wherein the ECG sensor is configured to: when the ECG signal is measured in a first mode, receive the ECG signal from a closed circuit formed by the first ECG sensor electrode and the second ECG sensor electrode, and when the ECG signal is measured in a second mode, receive the ECG signal from a closed circuit formed by electrodes of the at least two electrode patches.

These and other aspects of the present disclosure are disclosed in the following detailed description of the embodiments, the appended claims and the accompanying figures.

### BRIEF DESCRIPTION OF THE DRAWINGS

The disclosure is best understood from the following detailed description when read in conjunction with the accompanying drawings. It is emphasized that, according to common practice, the various features of the drawings are not to scale. On the contrary, the dimensions of the various features are arbitrarily expanded or reduced for clarity.

The description herein makes reference to the accompanying drawings, where like reference numerals refer to like parts throughout the several views.

FIG. 1A is a diagram of two example positions of a wearable device worn by an individual according to implementations of this disclosure.

FIG. 1B is a diagram of an example configuration when an electrocardiogram (ECG) signal can be received by the wearable device of FIG. 1A.

FIG. 2 is a diagram of an implementation of a wearable device usable within implementations of the disclosure.

FIG. 3 is diagram of an example computing device and an example hardware configuration of the computing device according to implementations of this disclosure.

FIG. 4A is a diagram of an example wearable device according to an implementation of this disclosure.

FIG. 4B is another diagram of an example wearable device according to an implementation of this disclosure.

FIG. 5 is a flowchart of an example process for acquiring an ECG signal according to implementations of this disclosure.

FIG. 6A is a flowchart of another example process for acquiring an ECG signal according to implementations of this disclosure.

FIG. 6B is a diagram of structures of an example main body of a wearable device according to implementations of this disclosure.

FIG. 7A is a flowchart of another example process for acquiring an ECG signal according to implementations of this disclosure.

FIG. 7B is a diagram of structures of another example main body of a wearable device according to implementations of this disclosure.

FIG. 8 is a diagram of an example process of heart activity monitoring using a wearable device according to implementations of this disclosure.

FIG. 9 is an example process of determining a heart activity monitoring mode according to implementations of this disclosure.

FIG. 10 is a flow diagram showing an example process for continuous ECG monitoring according to implementations of this disclosure.

FIG. 11 is a flow diagram showing an example process for episodic ECG monitoring according to implementations of this disclosure.

FIG. 12 is an example process of using multiple profiles to determine predicted labels according to implementations of this disclosure.

### DETAILED DESCRIPTION

Example implementations of the present disclosure will be described below with reference to the accompanying drawings. The same numbers across the drawings set forth in the following description represent the same or similar elements, unless differently expressed. The implementations set forth in the following description do not represent all implementations or embodiments consistent with the present disclosure; on the contrary, they are only examples of apparatuses and methods in accordance with some aspects of this disclosure as detailed in the claims.

As mobile health care market size keeps growing, devices and systems using wearable technologies to aid fitness or health assessments become more widely used. Among those technologies, mobile or wearable cardiac care devices and systems gain various applications, such as heart disease monitoring and engagement, biometric identification, and fitness tracking.

A wearable device can use various signals measured by various heart rate sensors as input, such as, for example, an electrocardiogram (ECG) signal and/or a photoplethysmogram (PPG) signal. Other sensors can also be used during the operation for additional input, such as a motion sensor. To place the heart rate sensors on a surface of a human body, the wearable devices can use various accessories as secure mechanisms, to which heart rate sensors of the wearable device can be attached.

According to implementations of this disclosure, a wearable device for heart activity monitoring can operate in episodic and continuous operation modes. The position of the wearable device, such as where the wearable device is attached to on the body of an individual can be determined prior to determining an operation mode to be used by the wearable device. The wearable device can work in either an episodic mode or a continuous mode for monitoring heart activities, depending on which body part it attaches to.

The wearable device can operate in at least two operation modes for heart activities monitoring: an episodic mode in which monitoring of heart-related activities is episodic or intermittent; and a continuous mode in which monitoring of heart-related activities is continuous or uninterrupted. Operating in the continuous mode can provide continuous measurement and processing of heart-related data, and further can provide real-time feedback to an individual for a change of cardiac status, such as, for example, recognition of a heart disease or its premonition. Meanwhile, operating in the episodic mode can provide measurements and processing for heart-related data when triggered (e.g., on demand), usually consuming less power and memory compared to the continuous mode, and further can use more sophisticated techniques to process measured data for a wide range of applications such as, for example, disease recognition, biometric

identification and determination of fitness or health status (e.g., stress level, fatigue level, or cardiac age).

In some implementations, the wearable device can monitor an ECG signal using one or more electrodes of an ECG sensor. The ECG signal can be either a unipolar ECG signal or a bipolar ECG signal. For example, in a 12-lead ECG, electrical heart activity of an individual can be recorded from electrodes placed on one or more body surfaces. The 12-lead ECG can provide spatial information about the electrical heart activity, each of the 12 leads representing a particular orientation in space in which the heart's electrical activity is measured. Among the 12 leads, Lead I (right arm to left arm), Lead II (right arm to left leg) and Lead III (left arm to left leg) are bipolar limb leads, and Leads V1, V2, V3, V4, V5 and V6 are unipolar chest leads. To form a bipolar limb lead for measurement, two electrodes need to be in contact with two skin surfaces of two limbs (e.g., right arm and left arm), respectively. To form a unipolar chest lead for measurement, one electrode needs to be in contact with the skin surface of the chest. The wearable device disclosed herein, for example, can have one or more electrodes, in which a bipolar limb lead can be formed when a different electrode of at least two electrodes get in contact with a surface of a different limb, or a unipolar chest lead can be formed when one of the electrodes get in contact with a surface on the chest. The term "contact" herein can refer to an electrode having a direct contact with bare skin, or the electrode having an indirect contact with bare skin with conductive material in between (e.g., a conductive patch or a conductive suit).

FIGS. 1A and 1B are diagrams showing some example positions of a wearable device worn by an individual according to implementations of this disclosure. As used throughout this disclosure, a wearable device can be implemented as any suitable wearable device, such as a device core, brace, wristband, limb band, leg band, ring, headband, or the like. In some implementations, the wearable device can include a portable component configured to travel with but not be worn by an individual, such as a key fob.

FIG. 1A is a diagram of two example positions of a wearable device **200** worn by an individual according to implementations of this disclosure. Wearable device **200** can include, for example, a device core **120** and one or more accessory components as housing, such as a wrist band **102** or a chest patch **104**, as shown in FIG. 1A. Wearable device **200** can include an electrocardiogram (ECG) component (e.g., an ECG sensor) comprising a first electrode and a second electrode (not shown) configured to measure various aspects of the individual's heart function and related biometrics. The ECG component, e.g., ECG sensor, can be included in or otherwise become part of device core **120**. The ECG component can also be implemented as a separate component attachable to the main body of the wearable device **200**.

In one example, the accessory component can include a wrist band **102**, and device core **120** can be removably attached to the wrist band **102**. In this setting (also referred to as the "wrist position"), the wearable device **200** can be attached to a wrist of the individual (on either limb, e.g., right limb **112** in FIG. 1A). The first electrode of the ECG sensor is coupled to an interior surface of the wearable device **200** facing skin of the individual that is wearing the wearable device **200**, in this case the individual's wrist. The second electrode is coupled to an exterior surface of the wearable device **200** and is not in direct contact with the individual that is wearing the wearable device **200**. The first electrode may or may not be in contact with the wrist at all

times when the wearable device **200** is worn. The first electrode and the second electrode are configured to identify electrical heart activity and transmitting the measurement data for subsequent processing. That is, upon the individual contacting second electrode, for example with a finger, the first electrode, if not already in contact with the individual's skin, contacts the skin to form a single lead ECG sensor, which permits the wearable device **200** to measure the individual's heart activity. A bipolar ECG signal (e.g., Lead I) can be received by the wearable device **200**, for example.

In another example, the accessory component can include a chest patch **104**, which can be attached to the chest **116** of the individual, and device core **120** can be removably attached to chest patch **104**. Chest patch **104** can be, for example, an adhesive patch, a sticker, or the like. When attached to the chest of the individual, the first electrode of the ECG sensor on the interior surface facing the skin of the individual can be in contact with the skin of chest **116**, which can form the lead to generate the electronic signals for heart activity measurements. A unipolar ECG signal (e.g., Lead V1, V2, V3, V4, V5 or V6) can be received by the wearable device **200**, for example.

FIG. 1B shows an example configuration when a bipolar ECG signal (e.g., Lead I) can be received by the wearable device **200**. In this example, the wearable device **200** is worn on the wrist of the right limb **112** of the individual. The first electrode on the interior surface of the wearable device **200** may or may not already be in contact with the individual's skin. When the individual contacts the second electrode on the exterior surface of the wearable device **200** using, for example, a fingertip of the left limb **114**, the first electrode, if not already in contact with the individual's skin, contacts the skin to form a bipolar ECG lead, which permits a measurement component of the wearable device **200** to receive a bipolar ECG signal (e.g., Lead I).

Depending on where (e.g., which part of the individual's body) the wearable device **200** is being attached to the body of the individual, the wearable device can operate in different modes, as will be described in detail below. In the examples, the wearable device **200** operate in a continuous mode for measuring unipolar heart activity signals when attached to the chest ("chest position"), and operate in an episodic mode for measuring bipolar heart activity signals when attached to the wrist ("wrist position"). Variations, modifications, and other arrangements are possible and not limited to the examples herein. For example, each of the operating modes (e.g., episodic or continuous) can be used to measure either unipolar or bipolar heart rate signals, in other configurations.

FIG. 2 is a diagram of an implementation of a wearable device **200** usable within implementations of the disclosure. Wearable device **200** can be the wearable device discussed above with respect to FIGS. 1A and 1B. For example, wearable device **200** can include a device core **120** and one or more accessory components as housing, such as the wrist band **102** or a chest patch (not shown).

In an implementation, device core **120** comprises CPU **202**, memory **204**, sensors **206**, and communications component **208**. One example of CPU **202** is a conventional central processing unit. CPU **202** may include single or multiple processors each having single or multiple processing cores. Alternatively, CPU **202** may include another type of device, or multiple devices, capable of manipulating or processing information now-existing or hereafter developed. Although implementations of wearable device **200** can be practiced with a single CPU as shown, advantages in speed and efficiency may be achieved using more than one CPU.

Memory **204** can comprise a random access memory device (RAM), a volatile memory, a non-volatile memory (e.g., a ROM), a flash drive, or any other similar storage medium, or any combination thereof. Memory **204** may include executable instructions and data for immediate access by CPU **202**, such as data generated and/or processed in connection with sensors **206**. Memory **204** may include one or more DRAM modules such as DDR SDRAM. Alternatively, memory **204** may include another type of device, or multiple devices, capable of storing data for processing by CPU **202** now-existing or hereafter developed. CPU **202** may access and manipulate data in memory **204** by a bus.

Sensors **206** can be one or more sensors disposed within or otherwise coupled to wearable device **200**, for example, for identifying, detecting, determining, or otherwise generating signal data indicative of measurements associated with the wearable device **200** and/or an individual wearing the wearable device **200**. In an implementation, sensors **206** can comprise one or more electromyography sensors, accelerometers, cameras, light emitters, touch sensors, or the like. The accelerometers can be three-axis, six-axis, nine-axis or any other suitable accelerometers. The cameras can be RGB cameras, infrared cameras, monochromatic infrared cameras, or any other suitable cameras. The light emitters can be infrared light emitting diodes (LED), infrared lasers, or any other suitable lights. Sensors **206** can comprise one or more sensors that can generate heart activity signals such as an electroencephalogram (EEG) sensor, a PPG sensor, an electromyogram (EMG) sensor, or the like. For example, the ECG sensor can comprise a first electrode arranged in an interior surface of device core **120**, which can be in contact with the skin of an individual when worn, and a second electrode arranged in an exterior surface of device core **120**. Sensors that can be included in the wearable device **200** can also include sensors capable of generating biometric signals, such as ECG signals, through non-invasive techniques such as without contacting the skin of the individual.

Sensors **206** can also comprise one or more bioimpedance sensors, microphones, temperature sensors, touch screens, finger readers, iris scanners, a combination of the above, or the like. Implementations of sensors **206** can include a single sensor, one of each of the foregoing sensors, or any combination of the foregoing sensors. In an implementation, the signal data can be identified, detected, determined, or otherwise generated based on any single sensor or combination of sensors included in wearable device **200**.

Communications component **208** can be a hardware or software component configured to communicate data (e.g., measurements, etc.) from sensors **206** to one or more external devices, such as another wearable device or a computing device, for example. In an implementation, communications component **208** comprises an active communication interface, for example, a modem, transceiver, transmitter-receiver, or the like. In an implementation, communications component **208** comprises a passive communication interface, for example, a quick response (QR) code, Bluetooth identifier, radio-frequency identification (RFID) tag, a near-field communication (NFC) tag, or the like. Communication component **208** can operate over wired or wireless communication connections, such as, for example, a wireless network connection, a Bluetooth connection, an infrared connection, an NFC connection, a cellular network connection, a radio frequency connection, or any combination thereof. In some implementations, communication component **208** can use sound signals as input and output, such as, for example, an ultrasonic signal or a

sound signal by an audio jack. Implementations of communications component 208 can include a single component, one of each of the foregoing types of components, or any combination of the foregoing components.

Wearable device 200 can also include other components not shown in FIG. 2. For example, wearable device 200 can include one or more input/output devices, such as a display. In an implementation, the display can be coupled to CPU 202 by a bus. In an implementation, other output devices may be included in addition to or as an alternative to the display. When the output device is or includes a display, the display may be implemented in various ways, including by a LCD, CRT, LED, OLED, etc. In an implementation, the display can be a touch screen display configured to receive touch-based input, for example, in manipulating data output to the display.

FIG. 3 shows a computing device 300 as an example and a block diagram of a hardware configuration of computing device 300 according to implementations of this disclosure. Computing device 300 can be a part of the system for heart activity monitoring disclosed herein. In some implementations, computing device 300 and wearable device 200 (or any device having measurement capabilities) can be the same device. Computing device 300 can be shown as an example type of computer in FIG. 3, but it is not limited to any specific type or any specific quantity in the system disclosed herein. Computing device 300 can be implemented by any configuration of one or more computers, such as a microcomputer, a mainframe computer, a super computer, a general-purpose computer, a special-purpose/dedicated computer, an integrated computer, a database computer, a remote server computer, a personal computer, a laptop computer, a tablet computer, a cell phone, a personal data assistant (PDA), a wearable computing device, e.g., a smart watch, or a computing service provided by a computing service provider, e.g., a website, or a cloud service provider. In some implementations, computing device 300 can be a smart phone device that can be used to display and analyze ECG signals. In some implementations, certain operations described herein can be performed by a computer (e.g., a server computer) in the form of multiple groups of computers that are at different geographic locations and can or cannot communicate with one another by way of, such as, a network. While certain operations can be shared by multiple computers, in some implementations, different computers can be assigned with different operations.

The computing device 300 can include at least one processor such as CPU 302. CPU 302 as well as CPU 202 can be any type of device, or multiple devices, capable of manipulating or processing information. Although the examples herein can be practiced with a single processor as shown, advantages in speed and efficiency can be achieved using more than one processor. CPU 302 can be distributed across multiple machines or devices (each machine or device having one or more of processors) that can be coupled directly or across a local area or other network. Although the examples herein can be practiced with a single processor as shown, advantages in speed and efficiency can be achieved using more than one processor.

Memory 304 as well as memory 204 can be, for example, a random access memory device (RAM), a read-only memory device (ROM), an optical disc, a magnetic disc, or any other suitable type of storage device, and can store code and data that can be accessed by CPU 302 using a bus 306. Although a single bus is depicted in FIG. 3, multiple buses can be utilized. Memory 304 can be distributed across multiple machines or devices such as network-based

memory or memory in multiple machines performing operations that can be described herein as being performed using a single computing device for ease of explanation. The code can include an operating system and one or more application program 310 processing and/or outputting the data. As will be discussed in detail below, application program 310 can include software components in the form of computer executable program instructions that can cause CPU 302 to perform some or all of the operations and methods described herein. In some implementations, the computing device 300 is used to implement computing device 300 or at least an analysis component of computing device 300, in which application program 310 stored by memory 304 can implement some or all of the processes as described in more detail below.

The computing device 300 can optionally include a storage device 308 in the form of any suitable non-transitory computer readable medium, such as a hard disc drive, a memory device, a flash drive or an optical drive. Storage device 308, when present, can provide additional memory when high processing requirements exist. Storage device 308 can also store any form of data, relating or not relating to cardiac information. Further, storage device can be a component of the computing device 300 or can be a shared device that is accessed by a network.

The computing device 300 can include more devices or components. For example, computing device can further include one or more input devices, output devices, communication devices, or any other device that can be used to transmit, store, process, and present data.

Although FIG. 3 depicts a hardware configuration of the computing device 300 that can implement computing device 300, other configurations can be utilized. The hardware configuration of a computing system as depicted in an example in FIG. 3 thus can be implemented in a wide variety of configurations.

FIG. 4A shows a diagram of an example wearable device 400 according to an implementation of this disclosure. FIG. 4B shows another diagram of the example wearable device 400 according to an implementation of this disclosure. The wearable device 400 can be implemented as, for example, the wearable device 200 in FIG. 2. As shown in FIGS. 4A and 4B, the wearable device 400 can include a detachable main body 402, a connecting portion (e.g., a wristband) 404, and multiple (e.g., two) electrode patches (not shown). The electrode patches can be provided separately from the wristband 404. The electrode patches can also be provided separately from the main body 402. The main body 402 can include an ECG sensor (not shown), a first ECG sensor electrode 406, and a second ECG sensor electrode 408. The first ECG sensor electrode 406 can be placed on a part of the main body 402 away from the worn position (e.g., a wrist), and the second ECG sensor electrode 408 can be placed on a part of the main body 402 near the worn position. The ECG sensor can electrically connect to the first ECG sensor electrode 406 and the second ECG sensor electrode 408 to collect an ECG signal from a closed circuit formed by the first ECG sensor electrode 406 and the second ECG sensor electrode 408. The electrode patches can be provided in a structure. By removing the main body 402 from the wearable device and fixing the removed main body 402 in the structure, the ECG sensor electrodes 406 and 408 in the main body 402 can be connected to electrodes of the electrode patches. The ECG sensor in the main body 402 can collect an ECG signal from a closed circuit formed by the first ECG sensor electrode 406, the second ECG sensor electrode 408, and the electrodes of the electrode patches.

The structure of the wearable device and the method of obtaining the ECG signal are described in examples as follows.

In some implementations, the ECG sensor can realize a simple or episodic ECG measurement mode by collecting the ECG signal from the closed circuit formed by the first ECG sensor electrode and the second ECG sensor electrode. By removing the main body from the wearable device, the ECG sensor electrodes in the removed main body can be connected to the electrode patches, and the ECG sensor can realize a continuous ECG measurement mode by collecting the ECG signal from the closed circuit formed by the first ECG sensor electrode, the second ECG sensor electrode, and the electrodes of the electrode patches. Implementations of this disclosure can provide a solution for both episodic ECG measurements and continuous ECG measurements.

FIG. 5 is a flowchart showing an example process 500 for acquiring an ECG signal according to implementations of this disclosure. As shown in FIGS. 4A, 4B, and 5, the process 500 can include operations 502 and 504 as follows.

At the operation 502, when the main body is connected to the connecting portion, the ECG sensor receives an ECG signal from a closed circuit formed by the first ECG sensor electrode and the second ECG sensor electrode.

At the operation 504, when the main body is connected to the electrode patches, the ECG sensor receives an ECG signal from a closed circuit formed by the first ECG sensor electrode, the second ECG sensor electrode, and electrodes of the electrode patches.

In an implementation, the wearable device can include a wristband. The ECG measurement at the operation 502 can be the episodic ECG measurement, such as, for example, an ECG measurement on a wrist performed by the ECG sensor electrodes of the wearable device. The ECG measurement at the operation 504 can be in the continuous ECG measurement mode, such as, for example, an ECG measurement on chest performed by two or more electrode patches associated with the wearable device.

For example, at the operation 502, as shown in FIGS. 4A and 4B, the user can wear the wearable device on the left wrist. The second ECG sensor electrode 408 can touch skin of the left wrist. When the user touches the first ECG sensor electrode 406 using the right hand, the first ECG sensor electrode 406 and the second ECG sensor electrode 408 can form a closed circuit through the user body, and the ECG sensor can collect the ECG signal from the closed circuit.

At the operation 504, for the user wearing the wearable device, the main body 402 can be removed or detached from the wearable device for the continuous ECG measurement mode. The removed main body 402 can be connected to the electrode patches in various ways (e.g., by clipping, snapping, or adhesion). For example, two electrode patches can be provided in the structure, and the removed main body 402 can be fixed (e.g., clipped or adhered) to the structure and connected to the two electrode patches. When removed, the main body 402 can be separated from the wristband 404. For example, the two electrode patches can be adhered to the chest of the user. The electrodes of the two electrode patches can be connected to the first ECG sensor electrode 406 and the second ECG sensor electrode 408, respectively. The ECG sensor can collect the ECG signal from the closed circuit formed by the first ECG sensor electrode, the second ECG sensor electrode, and the electrodes of the two electrode patches. Although two electrode patches are used as examples for ease of explanation, it should be noted that the number of the electrode patches can be any number greater than or equal to two.

In some implementations, the electrode patches can include a battery, or can include no battery. When the electrode patches include the battery, the battery can be used as a secondary power source to power the wearable device for effectively performing the continuous ECG measurements.

FIG. 6A is a flowchart of an example process 600A for acquiring an ECG signal according to implementations of this disclosure. FIG. 6B is a diagram of structures of an example main body 600B of a wearable device for ECG measurements. The main body 600B can implement the process 600A. As shown in FIGS. 4A, 4B, and 6A, after the operation 504, the method for acquiring the ECG signal can further include operations 602 and 604 as follows.

At the operation 602, a user state of a user of the wearable device can be determined using a microcontroller unit (MCU) from an accelerometer. Based on the user state, the received ECG signal can be processed, and a process result can be obtained.

In an implementation, as shown in FIG. 6B, in addition to a first ECG sensor electrode 406, a second ECG sensor electrode 408, and an ECG sensor 606, the main body 600B of the wearable device can further include an accelerometer 608 and an MCU 610 (e.g., a microprocessor). The accelerometer 608 can be used to determine the user state for the user wearing the wearable device. For example, the user state can include a static state and a moving state. Based on the user state determined using the accelerometer 608, the MCU 610 can process the received ECG signal and obtain a process result. For example, the MCU 610 can filter the received ECG signals in accordance with different user states.

For example, the MCU 610 can determine accuracy for the received ECG signals based on the user state. The MCU 610 can also process the ECG signals received under different user states according to actual needs. For example, when the user wearing the wearable device is exercising, the received ECG signals may have lower quality (e.g., with a large drift), and the MCU 610 can perform more filtering operations to the received ECG signals.

It should be noted that, in some implementations, the accelerometer 608 can be omitted in the main body of the wearable device. In those implementations, the ECG signals received by the ECG sensor can be directly processed by the MCU 610 to obtain the process result. For example, when the main body of the wearable device does not include the accelerometer 608, the MCU 610 can process the ECG signals received by the ECG sensor using similar or the same techniques. When the user wearing the wearable device is in the static state, the process result can be the same as the process result obtained by the wearable device with the accelerometer 608 included.

At the operation 604, the process result is sent to a host device by the MCU by a communication device. Based on the process result, the host device can detect a disease or identify an identity.

As shown in FIG. 6B, the main body of the wearable device can further include a communication device 612. By the communication device 612, the MCU can send the process result obtained at the operation 602 to the host device for disease detection or identity identification. When the process result includes indicative information, the accuracy for the disease detection and identity identification can be increased. For example, the indicative information can include the user states of the user wearing the wearable device.

In some implementations, the host device can include a server or a terminal device (e.g., a cell phone).

In this implementation, the MCU 610 can obtain the user state using the accelerometer 608, based on which the MCU can process the received ECG signals and send the process result to the host device by the communication device. Based on the process result, the host device can detect a disease or identify an identity, in which the accuracy of the disease detection and the identity identification can be increased.

FIG. 7A is a flowchart showing an example process 700A for acquiring an ECG signal according to implementations of this disclosure. As shown in FIG. 7A, after the operation 602, the method for acquiring the ECG signal can further include operation 704 as follows.

At the operation 704, when the MCU detects the process results reaches or meets a preset threshold, an emergent notification or an alarm can be performed.

For example, as shown in FIG. 7B, based on FIG. 6B, the main body of the wearable device can further include a motor 614. In addition, the main body can further include a battery (not shown), which can provide power for the wearable device.

For example, when the MCU 610 detects that a heart rate reaches a predetermined threshold, a notification or an alarm can be performed by the motor 614 to indicate to a relative or a friend of the user that the user wearing the wearable device is sick or in emergency. The predetermined threshold can be set according to actual needs. Based on the warning, the relative or the friend of the user can take action for the health status of the user in time, by which the user's safety can be secured.

Corresponding to the above-described methods and processes, a control logic for acquiring an ECG signal is also provided in this disclosure. The control logic for acquiring the ECG signal can be applied to a wearable device, which can include a main body, a securing portion, and multiple (e.g., two) electrode patches. The main body can include a processor (e.g., a CPU or a MCU), an ECG sensor, a first ECG sensor electrode, a second ECG sensor electrode, and a machine-readable storage medium (e.g., a RAM or a ROM). The processor and the machine-readable storage medium can be connected by an internal bus. In some implementations, the main body can further include a communication interface, by which the wearable device can communicate with other devices or components.

FIG. 8 is a flowchart of an example process 800 of monitoring heart activity using a wearable device according to implementations of this disclosure. The process 800 can be performed on a wearable device (e.g., wearable device 200 or 400) on which the sensor data is collected or generated, or on another wearable device and/or a computing device (e.g., computing device 300) in communication with one or more wearable devices. For example, the sensor data processing aspects of the process 800 can be performed by instructions executable on the computing device. In some implementations, portions of the process 800 can be performed by instructions executable on the computing device and/or one or more other devices, such as a wearable device. In some implementations, the computing device 300 can be a cell phone or a wearable device such as a smart watch, which can receive and display signals. In some implementations, the computing device 300 can be a cloud server. The heart activity being monitored can include, for example, prediction data or events associated with certain heart diseases ("disease prediction"). In addition, the wearable device 200 or 400 can be used for prediction data or events

associated with fitness activities ("fitness prediction"), or biometric identification. The fitness activities can include, for example, emotion, stress, or heart age prediction.

At operation 802, an electrocardiograph (ECG) signal and a motion signal associated with an individual are received. The ECG signal and the motion signal can be generated by the wearable device 200 or 400 upon detecting a contact by the individual with the wearable device 200 or 400. The ECG signal and the motion signal can be received by the wearable device 200, 400 and/or the computing device 300.

Sensor signals, such as the ECG signal and the motion signal, can be generated and outputted by, for example, one or more sensors in the wearable device 200 or 400. Examples of generating the ECG signal have been described in FIGS. 1A and 1B when, such as, for example, at least one of the electrodes of an ECG sensor gets in contact with the skin of the individual. The wearable device 200 or 400 can be in contact with the individual by one or more electrodes of the ECG sensor(s) included in the wearable device. For example, the individual can get in contact with the wearable device by one of tapping, pressing, holding, wearing or otherwise touching one or more electrodes of the wearable device 200 or 400. For example, in FIG. 1A, once the wearable device 200 or 400 is worn on the individual's chest or wrist, the individual is in contact with the wearable device 200 or 400, upon which the ECG signal and the motion signal can be generated.

The motion signal can be generated by a motion sensor in the wearable device 200 or 400, which can be used to determine linear or angular motion characteristics of the wearable device 200 or 400, such as, for example, velocity, acceleration, speed, direction, or inertia. In some implementations, the motion sensor can be an accelerometer, a gyroscope, a magnetometer, an Inertial Measurement Unit (IMU), or any combination of any sensor for detecting motion characteristics of the wearable device. When the individual is wearing the wearable device 200 or 400 on a body part (e.g., wrist or chest), the motion signal can be used to indicate the motion characteristics of that body part of the individual.

In some implementations, the ECG signal and the motion signal can be received by the wearable device. In some other implementations, the ECG signal and the motion signal can be received by the wearable device and transmitted to another computing device, such as the computing device 300. The "receiving" used herein can refer to receiving, inputting, acquiring, retrieving, obtaining, reading, accessing, determining, or in any manner inputting data. The ECG signal and the motion signal can be received concurrently, or at different times. As used herein, information, signals, or data are received by transmission or accessing the information, signals, or data in any form, such as receiving by transmission over a network, receiving by accessing from a storage device, or receiving by individual operation of an input device.

At operation 804, in response to receiving the ECG signal and the motion signal associated with the individual, a position of the wearable device in contact with the individual is determined. The position of the wearable device in contact with the individual can be a position of the individual body where the wearable device is worn, such as the positions shown in FIGS. 1A-1B. The position can be on, for example, a limb end (e.g., a wrist, an ankle), an arm, a leg, chest, torso, etc. The position of the wearable device in contact with the individual can be determined based on the received signals, for example, at least one of the motion signal and the ECG signal received at the operation 802. In

some implementations, the position can be determined based on the motion signal without using the ECG signal. In some other implementations, the position can be determined based on both the motion signal and the ECG signal. For example, to determine the position of the wearable device **200** or **400**, the motion signal data (e.g., accelerator signal data) can be input to rule-based or statistical models, which can be generated by offline training based on labeled data (e.g., data associated with known body positions). By analyzing the motion characteristics of the wearable device **200** or **400** upon receiving the ECG signal, the position of the wearable device **200** or **400** can be determined automatically, which can be used to select a heart activity monitoring mode for operating the wearable device **200** or **400**. Details of determining the position of the wearable device are set forth in the following description of FIG. **9**.

At operation **806**, a heart activity monitoring mode for operating the wearable device is determined based on the position of the wearable device in contact with the individual. The heart activity being monitored can include, for example, prediction events associated with certain heart diseases (“disease prediction”). For example, the heart activity monitoring mode can be a heart disease monitoring mode that is capable of detecting cardiac disease in real time. Different heart activity monitoring modes can be used to monitor heart activities episodically or continuously. The modes can be triggered or activated based on the position of the wearable device **200** or **400** in contact with the individual. In each heart activity monitoring mode (e.g., episodic mode and continuous mode), a different operations can be performed accordingly by the wearable device **200** or **400**, examples of which are shown and described in FIGS. **9-11**.

FIG. **9** is an example process **900** of determining a heart activity monitoring mode according to implementations of this disclosure. The process **900** can be implemented by or incorporated into the operation **806** of FIG. **8**, for example.

At operation **902**, it can be determined whether the position of the wearable device in contact with the individual is a chest position or a wrist position. The position of the wearable device in contact with the individual can be determined at, for example, the operation **804**, based on the motion signal and/or ECG signal. The motion characteristics extracted from the measured motion signal can have different patterns for one or more body parts in motion (e.g., the wrist position or the chest position), which can be compared with predetermined characteristics associated with the one or more body parts. If a match between the extracted motion characteristics and a predetermined characteristics associated with a specific body part is found as a result of the comparison, the position of the wearable device can be determined as that body part. The predetermined characteristics can be, for example, profile data determined from a training process, which can be based on labelled data associated with known positions.

At operation **904**, when the wearable device is determined to be on the chest, the heart activity monitoring mode for operating the wearable device is determined as a mode indicative of continuous monitoring of ECG signals received by the wearable device. This mode is also referred to as the “continuous mode.” In some implementations, the continuous mode can be the second mode as described above. When operating in the continuous mode, the wearable device can monitor the ECG signals continuously for the individual (“continuous monitoring”). For example, monitoring of the ECG signals can be continuous until wearable device **200** or **400** exits the second mode, such as, for example, the

individual takes the wearable device **200** or **400** off the chest position. An example process of continuous monitoring in the second mode is described below in FIG. **10**.

At operation **906**, when the wearable device is determined to be on the wrist, the heart activity monitoring mode for operating the wearable device is determined as a mode indicative of episodic monitoring of ECG signals received by the wearable device. This mode is also referred to as the “episodic mode.” In some implementations, the episodic mode can be the first mode as described above. When operating in the episodic mode, the wearable device can monitor the ECG signals episodically for the individual (“episodic monitoring”). The monitoring of the ECG signals in the episodic mode can be triggered by, for example, a further action of the individual. For example, when wearable device **200** or **400** is worn on and therefore in contact with the wrist of the individual by a first electrode on a first surface (e.g., an interior surface of the wrist band), a triggering action can be when the individual touches a second electrode on a second surface (e.g., an exterior surface) with another hand (e.g., a fingertip of the other hand). The episodic mode can be triggered and performed for a certain period of time, such as, for example, for several seconds or minutes. An example process of episodic monitoring in the first mode is described below in FIG. **11**.

In some implementations, the position of the wearable device can be determined based on the motion signal without using the ECG signal. In other implementations, the position of the wearable device can be determined based on both the motion signal and the ECG signal. For example, when the ECG signal is received from two electrodes, the ECG signal can be determined as a bipolar limb lead (e.g., Lead I, II, or III). Based on the motion characteristics determined from the motion signal, the position of the wearable device being worn can be determined as on a limb position (e.g., a wrist). In another example, when the ECG signal is received from only one electrode, the ECG signal can be determined as a unipolar lead (e.g., Lead V1, V2, V3, V4, V5, or V6), which is commonly used as a chest lead. Based on the results of the motion characteristics comparison and the lead type, the position of the wearable device can be determined, such as on chest or another position. Other than the examples disclosed herein, the methods and processes to determine the position of the wearable device or the measurement component can use any combination of any sensor data as input. In addition, the “wrist position” and the “chest position” are just two examples of body positions. Other positions that can be used include, for example, a limb position (e.g., on arm, leg, knee, or ankle), a shoulder position, a torso position (e.g., on chest or abdomen), or any other body position of an individual that can be used to measure an ECG signal. Details of operating in different heart activity monitoring modes (e.g., continuous mode or episodic mode) will be described below in FIGS. **10** and **11**.

FIG. **10** is a flowchart showing an example process **1000** for continuous monitoring of heart activity (“continuous mode”). The process **1000** can be carried out following the process **800** or **900**, for example, upon determining that continuous mode is to be used for monitoring the ECG signals at the operation **806** or **904**. For example, the process **1000** can be triggered when it is determined that continuous mode is to be used for operating the wearable device at the operation **904**. The process **1000** can also be activated by the individual by manually setting the operating mode as the continuous mode by software or hardware, such as by the application program **310**. The continuous mode can monitor heart activity of the individual in real-time and further

provide feedback data to the individual. The feedback data can include data indicative of, for example, a heart disease or a health status.

At operation **1002**, the received ECG signals are pre-processed to generate a denoised signal. The term “noise” of a signal can herein refer to any artifact or background that obscures or reduces the clarity of the signal (e.g., disturbance, distortion, or deviation). Sources of noise of the ECG signal can include, for example, EMG background, baseline wandering, powerline interference, and motion artifacts. The pre-processing can perform operations to reduce or remove the noise from the ECG signal.

At operation **1004**, R peaks are detected from the denoised ECG signal. The ECG signal can include PQRST cycles. A PQRST cycle of an ECG signal is defined as a portion of the ECG signal that represents one complete heartbeat, which consists of a P wave, a QRS complex and a T wave connected in temporal order. The peak of a QRS complex is defined as an R peak, and a time interval between two adjacent R peaks (“RR interval”) represents the length of a heartbeat.

At operation **1006**, the ECG signal is processed by segmenting the denoised signal based on the detected R peaks. For example, after detecting R peaks, ECG periodic fragments (e.g., QRS complexes) can be extracted from the denoised signal by directly taking signal data around the R peaks, or by any other technique that can be used to extract ECG periodic segments.

At operation **1008**, it is determined whether the processed ECG signal matches a predefined profile. The profile can include template data that can be extracted from a training process such as an offline training operation **1012**. The profile can be associated with, for example, a known disease (“disease profile”) or a known individual (“individual profile”). For example, a disease profile can be associated with, for example, a premature ventricular contraction (PVC) event, a premature atrial contraction (PAC) event, a ventricular tachycardia event, an atrial fibrillation event, a first or second or third degree heart block event, and so forth. Predefined profiles such as disease profiles can be generated from offline training using labelled data, such as data associated with known diseases described above. The offline training can be based on, for example, labeled data from segmented denoised ECG signal data based on the R peaks at operation **1006**. The profile can also be associated with a status indicative of a health status or a fitness status of the individual, such as, for example, stress level or heart age. The status profile can include characteristic data that can be extracted from the training process, such as the offline training operation **1012**. Alternatively, the status can also be determined by regression or by a classification model, using the processed ECG signal data.

In some implementations, the template data or the characteristic data can be graphical data. In some other implementations, the template data and the characteristic data can include data indicative of graphical characteristics of the profile or the status. More than one predetermined profile or status can be used to find match. The processed ECG signal can be determined as matching to one of the one or more predetermined profiles. Several example profiles that can be used at operation **1008** are shown in FIG. **12**. As shown in FIG. **12**, the profile can be, for example, a predefined profile of a known individual at **1202**, a predefined profile of a known heart disease at **1206** or a profile associated with health status at **1210**.

Back to operation **1008**, in some implementations, the match can be determined based on similarity between the

processed ECG signal and each profile. For example, for a profile, a quantity or value (“similarity score”) can be calculated between the graphical characteristics (e.g., shape) of the processed ECG signal and the graphical characteristics of the template data. In this example, the highest similarity score can be used to indicate a match between the processed ECG signal and the profile or the status associated with the highest similarity score. In another example, for each profile or status, a similarity score can also be similarly calculated, and when the similarity score exceeds a predetermined threshold, it can be indicated a match between the processed ECG signal and the current profile or status under consideration. In still another example, the characteristic data of the processed ECG signal can be compared with the characteristic data of a status. Besides the above examples, various criteria can be used to determine the match between the processed ECG signal and the profiles. In addition, criteria based on other factors (e.g., trend, curve or cue) can also be used to determine the match between the processed ECG signal and the profiles.

If a match is found between the processed ECG and a profile or a status, the process **1000** proceeds to operation **1010**. Otherwise, the process **1000** goes back to operation **1002**, using a new ECG signal as input. At the operation **1010**, a predicted label, e.g., a predicted event, associated with the individual is determined. The predicted label can include any data that is indicative of the matched profile or status at the operation **1008**. Several examples of predicted labels are described in FIG. **12**. For example, it can be indicated that the individual is the known individual when there is a match at operation **1204** (“biometric identification”). It can be indicated that the individual is associated with a known heart disease at the operation **1208** (“disease identification”), or that a certain health status is associated with the individual at operation **1212** (“status indicator”).

After the operation **1010**, the process **1000** can go back to the operation **1002**, using a new ECG signal as input. The process **1000** can be repeated continuously or periodically, until the wearable device exits the continuous mode, such as by being removed from the chest position or by being manually set by the individual.

FIG. **11** is a flowchart showing an example process **1100** for episodic monitoring of heart activity (“episodic mode”). The process **1100** can be carried out following the process **800** or **900**, for example, upon determining that episodic mode is to be used for monitoring the ECG signals at the operation **806** or **906**. For example, the process **1100** can be triggered when it is determined that episodic mode is to be used for operating the wearable device at the operation **906**. The process **1100** can also be activated by the individual by manually setting the operating mode as the episodic mode by software or hardware, such as by the application program **310**. The episodic mode can monitor heart activity of the individual on-demand, allowing more complex processing and analysis on the signals, and further provide feedback data to the individual. The feedback data can include data indicative of, for example, a heart disease or a health status. Where operations are substantially similar to those in the process **1000**, reference will be made to the description above. There are some differences, however, that are pointed out in the following description of the process **1100**.

At operation **1102**, similar to operation **1002**, the received ECG signals are pre-processed to generate a denoised signal. Sources of noise of the ECG signal can include, for example, EMG background, baseline wandering, powerline interfer-

ence, and motion artifacts. The pre-processing can perform operations to reduce or remove the noise from the ECG signal.

At operation **1104**, one or more features are extracted from the denoised signal. The extracted features can include, for example, time domain features and frequency domain feature. The time domain features are features in a time domain representation of the signal, such as fiducial points of a graphical ECG signal, RR intervals, or wave fragments. The frequency domain features are features in a frequency domain representation of the signal, such as parameters and outputs from a Fast Fourier Transform (FFT), a wavelet transform, or the combination of an autocorrelation and a discrete cosine transform (AC-DCT).

At operation **1106**, the one or more features extracted from the denoised signal are classified using a trained classifier. The trained classifier can be one or more previously trained models that can be used for classification (“classification model”), e.g., a statistical model. The classifier can be trained using, for example, a learning technique such as various machine learning techniques. The classifier can be trained by, for example, offline or online training using labelled data, such as data with known diseases described above in the process **1000**. For example, the predicted label can be determined using the classifier.

In a setup process, such as prior to its use for prediction or testing, the classifier can be trained at the operation **1110**. The classifier can also be updated during the prediction process or testing by updating the parameters in the classification model. Labelled data associated with a known disease, a known individual, or a known health status can be used for training the classifier at the operation **1110**. For example, the labelled data associated with a known disease can include, for example, data indicative of a premature ventricular contraction (PVC) event, data indicative of a premature atrial contraction (PAC) event, data indicative of a ventricular tachycardia event, an atrial fibrillation event, first, second or third degree heart block event, and so forth. The training can be based on, for example, labeled data from features extracted at the operation **1106**. Data with different labels can be used to train the classifier to predict different labels, e.g., different disease labels or fitness statuses. Machine learning based techniques can be used for training at the operation **1110**, which can include, for example, a support vector machine (SVM) technique, metric learning, deep learning etc. For example, the techniques can result in a weight that reflects the relative importance of an extracted feature as compared to all features, which can be used for determination at the operation **1106** or **1108**. In addition, the operation **1110** may be performed by a cloud server or elsewhere and may include data for extracted features collected from a relatively large population of individuals as training data.

At operation **1108**, one or more predicted labels associated with the individual are determined. The predicted labels can be determined by the classifier described at the operation **1106**. The predicted label can be used, for example, to identify a predicted event (e.g., identification of a disease, a person or a fitness status), which can be indicated to the individual on a display of the wearable device or the computing device. The predicted label can be generated by the classifier based on the extracted one or more features. In some implementations, some or all of the features extracted at the operation **1106** can be provided to the operation **1110** to combine with other data for offline training.

After the operation **1108**, the process **1100** can go back to the operation **1102**, waiting for a new ECG signal as input.

The new ECG signal can be generated, for example, when the individual performs an action by using a hand to touch the second electrode (on exterior surface) of the wearable device worn on the other hand again. The process **1100** can be repeated once the new ECG signal is received, until the wearable device exits the episodic mode, such as by being removed from the wrist position or by being manually set by the individual.

FIG. **12** is an example process **1200** of using multiple profiles to determine predicted labels according to implementations of this disclosure. The process **1200** can be carried out following the operation **1006** or **1104**, for example.

At operation **1202**, it is determined whether the processed ECG signal matches a predefined profile of a known individual. If it does, a first predicted label indicating the individual is the known individual is determined at the operation **1204**. The operations **1202-1204** can be used, for example, for biometric identification.

At operation **1206**, it is determined whether the processed ECG signal matches a predefined profile of a known heart disease. If it does, a second predicted label indicating the individual is associated with the known heart disease is determined at operation **1208**. The operations **1206-1208** can be used, for example, for real-time heart disease monitoring. For example, the second predicted label can include an indicator for a heart disease event. The heart disease event can include, for example, a premature ventricular contraction (PVC) event, a premature atrial contraction (PAC) event, a ventricular tachycardia event, an atrial fibrillation event, a first or second or third degree heart block event, and so forth.

At operation **1210**, it is determined whether the processed ECG signal matches a health or fitness status. If it does, the health or fitness status is determined as associated with the individual at the operation **1212**. The health or fitness status can relate to one or more of weight, heart rate, fatigue level, stress level, heart age, heart rate variability (HRV), and a heart condition. For example, the health status can be numerical or non-numerical data indicative of a stress level or fatigue level of the individual. For another example, the health status can be a numerical heart age or cardiac age of the individual.

The representation of predicted labels, such as the disease or biometric identification, the health or fitness status, which is often used as feedback to the individual can be, for example, a number, a text, a color, a sound, an icon, a vibration, or any combination of any visual, acoustic, and tactile output.

In some implementations, such as when a classifier is used to predict multiple labels, the operations **1202**, **1206**, and **1210** can be combined into a single classification operation, e.g., the operation **1106**. Multiple labels generated at the operation **1106** can then be used to provide feedback data to the individual at, for example, the operations **1204**, **1208**, and **1212**.

In some implementations, the operations **1002-1010**, **1104-1106**, **1202-1212** and can be performed by an analysis component, either included in the wearable device (e.g., a smart watch) or another computing device (e.g., a smart phone or a server computer). When the analysis component is not included in the wearable device, the measurement component can communicate data with the analysis component by the communication component **208** of the wearable device. For example, the communication can be estab-

lished by a wireless connection (e.g., Bluetooth, infrared, Wi-Fi, NFC, ultrasound) or a wired connection (e.g., USB, audio jack).

The measurement component and the analysis component that perform the various operations described herein can be a same component, different components at a same device or at different devices. The wearable device and the computing device that performs the various operations described herein can be a same device or different devices. In some implementations, the measurement component and the accessory component can be a same component or different components.

The aspects herein can be described in terms of functional block components and various processing operations. Such functional blocks can be realized by any number of hardware and/or software components that perform the specified functions. For example, the described aspects can employ various integrated circuit components, e.g., memory elements, processing elements, logic elements, look-up tables, and the like, which can carry out a variety of functions under the control of one or more microprocessors or other control devices. Similarly, where the elements of the described aspects are implemented using software programming or software elements the disclosure can be implemented with any programming or scripting language such as C, C++, Java, assembler, or the like, with the various algorithms being implemented with any combination of data structures, objects, processes, routines or other programming elements. Functional aspects can be implemented in algorithms that execute on one or more processors. Furthermore, the aspects of the disclosure could employ any number of conventional techniques for electronics configuration, signal processing and/or control, data processing and the like. The words “mechanism” and “element” are used broadly and are not limited to mechanical or physical embodiments or aspects, but can include software routines in conjunction with processors, etc.

Implementations or portions of implementations of the above disclosure can take the form of a computer program product accessible from, for example, a computer-usable or computer-readable medium. A computer-usable or computer-readable medium can be any device that can, for example, tangibly contain, store, communicate, or transport a program or data structure for use by or in connection with any processor. The medium can be, for example, an electronic, magnetic, optical, electromagnetic, or a semiconductor device. Other suitable mediums are also available. Such computer-usable or computer-readable media can be referred to as non-transitory memory or media, and can include RAM or other volatile memory or storage devices that can change over time. A memory of an apparatus described herein, unless otherwise specified, does not have to be physically contained by the apparatus, but is one that can be accessed remotely by the apparatus, and does not have to be contiguous with other memory that might be physically contained by the apparatus.

Any of the individual or combined functions described herein as being performed as examples of the disclosure can be implemented using machine readable instructions in the form of code for operation of any or any combination of the aforementioned computational hardware. Computational code can be implemented in the form of one or more modules by which individual or combined functions can be performed as a computational tool, the input and output data of each module being passed to/from one or more further module during operation of the methods and systems described herein.

Information, data, and signals can be represented using a variety of different technologies and techniques. For example, any data, instructions, commands, information, signals, bits, symbols, and chips referenced herein can be represented by voltages, currents, electromagnetic waves, magnetic fields or particles, optical fields or particles, other items, or a combination of the foregoing.

While the disclosure has been described in connection with certain embodiments and implementations, it is to be understood that the invention is not to be limited to the disclosed embodiments but, on the contrary, is intended to cover various modifications and equivalent arrangements included within the scope of the appended claims, which scope is to be accorded the broadest interpretation so as to encompass all such modifications and equivalent structures as is permitted under the law.

All references, including publications, patent applications, and patents, cited herein are hereby incorporated by reference to the same extent as if each reference were individually and specifically indicated as incorporated by reference and were set forth in its entirety herein.

What is claimed is:

1. A method for measuring an electrocardiograph (ECG) signal for a user wearing a wearable device, comprising:
  - receiving motion information of the wearable device;
  - determining, using the motion information, whether to measure the ECG signal using a first mode or a second mode, wherein the first mode comprises an episodic mode and the second mode comprises a continuous mode;
  - when the ECG signal is measured in the first mode, receiving the ECG signal by an ECG sensor from a closed circuit formed by a first ECG sensor electrode and a second ECG sensor electrode, wherein the wearable device comprises a main body detachable to the wearable device, a connecting portion, and electrode patches, and the main body comprises the ECG sensor, the first ECG sensor electrode, and the second ECG sensor electrode; and
  - when the ECG signal is measured in the second mode, receiving the ECG signal by the ECG sensor from a closed circuit formed by electrodes of the electrode patches, wherein the ECG sensor is in the main body and the main body is connected to the electrode patches, wherein when the ECG measurement is performed in the second mode, the main body is detached from the wearable device and connected to the electrode patches by snap-fit or adhesive, and a securing portion is detached from the main body and the electrode patches.
2. The method of claim 1, wherein the main body further comprises an accelerometer and a microcontroller unit (MCU), and the method further comprises:
  - receiving, by the MCU from the accelerometer, a status for the user, and determining processed data by processing the ECG signal based on the status; and
  - sending the processed data to a host device by wired or wireless communications, wherein the host device determines at least one of a disease and an identity based on the processed data.
3. The method of claim 1, wherein the main body further comprises a microcontroller unit (MCU), and the method further comprises:
  - determining processed data by processing the ECG signal using the MCU; and

sending the processed data to a host device by wired or wireless communications, wherein the host device determines at least one of a disease and an identity based on the processed data.

4. The method of claim 3, wherein the main body further comprises a motor, and the method further comprises:

when the MCU determines that the processed data reaches a preset threshold value, performing a vibration notification using the motor.

5. The method of claim 1, wherein the electrode patches comprise a battery, the battery used as a secondary power source to the wearable device when the ECG signal is measured in the second mode.

6. An apparatus for measuring an electrocardiograph (ECG) signal for a user wearing a wearable device, comprising:

an ECG sensor;

a first ECG sensor electrode;

a second ECG sensor electrode;

sensors including an accelerometer;

a microcontroller unit (MCU);

a processor; and

a memory configured to store instructions which when executed by the processor become operational with the processor to:

receive, by the MCU from the accelerometer, a status for the user;

receive, from a sensor of the sensors, motion information of the wearable device;

determine, using the motion information, whether to measure the ECG signal using a first mode or a second mode;

when the ECG signal is measured in the first mode, receive the ECG signal by the ECG sensor from a closed circuit formed by the first ECG sensor electrode and the second ECG sensor electrode, wherein the wearable device comprises a main body detachable to the wearable device, a connecting portion, and electrode patches, and the main body comprises the ECG sensor, the first ECG sensor electrode, and the second ECG sensor electrode; and

when the ECG signal is measured in the second mode, receive the ECG signal by the ECG sensor from a closed circuit formed by electrodes of the electrode patches, wherein the ECG sensor is in the main body and the main body is connected to the electrode patches.

7. The apparatus of claim 6, wherein when the ECG measurement is performed in the second mode, the main body is detached from the wearable device and connected to the electrode patches by snap-fit or adhesive, and a securing portion is detached from the main body and the electrode patches.

8. The apparatus of claim 6, wherein the memory further comprises instructions which when executed by the processor become operational with the processor to:

determine processed data by processing the ECG signal using the MCU; and

send the processed data to a host device by wired or wireless communications, wherein the host device is for determining at least one of a disease and an identity based on the processed data.

9. The apparatus of claim 8, the main body further comprises a motor, and the memory further comprises instructions which when executed by the processor become operational with the processor to:

when the MCU determines that the processed data reaches a preset threshold value, perform a vibration notification using the motor.

10. The apparatus of claim 6, wherein the electrode patches comprise a battery, the battery used as a secondary power source to the wearable device when the ECG signal is measured in the second mode.

11. The apparatus of claim 6, wherein the first mode comprises an episodic mode and the second mode comprises a continuous mode.

12. A wearable device for measuring an electrocardiograph (ECG) signal for a user, comprising:

a main body detachable from the wearable device, comprising a first ECG sensor electrode provided on an inner surface of the main body, a second ECG sensor electrode provided on an outer surface of the main body, and an ECG sensor;

a securing portion comprising a wrist band; and

at least two electrode patches, detached from the main body and the securing portion, wherein the ECG sensor is configured to:

receive, from a sensor of the wearable device, motion information of the wearable device;

determine, using the motion information, whether to measure the ECG signal using a first mode or a second mode;

when the ECG signal is measured in the first mode, receive the ECG signal from a closed circuit formed by the first ECG sensor electrode and the second ECG sensor electrode; and

when the ECG signal is measured in the second mode, receive the ECG signal from a closed circuit formed by electrodes of the at least two electrode patches.

13. The wearable device of claim 12, wherein when the ECG measurement is performed in the second mode, the main body is detached from the wearable device and connected to the at least two electrode patches by snap-fit or adhesive, and the securing portion is detached from the main body and the electrode patches.

14. The wearable device of claim 12, wherein the main body further comprises:

an accelerometer, configured to receive a status for the user;

a microcontroller unit (MCU), configured to receive the status from the accelerometer and determine processed data by processing the ECG signal received from the ECG sensor based on the status; and

a communication device, configured to send the processed data to a host device by wired or wireless communications, wherein the host device is for determining at least one of a disease and an identity based on the processed data.

15. The wearable device of claim 12, wherein the main body further comprises:

a microcontroller unit (MCU), configured to determine processed data by processing the ECG signal received from the ECG sensor; and

a communication device, configured to send the processed data to a host device by wired or wireless communications, wherein the host device is for determining at least one of a disease and an identity based on the processed data.

16. The wearable device of claim 15, wherein the main body further comprises a motor, and the MCU is configured to perform a vibration notification using the motor when determining that the processed data reaches a preset threshold value.

**23**

**24**

17. The wearable device of claim 12, wherein the at least two electrode patches comprise a battery, the battery used as a secondary power source to the wearable device when the ECG signal is measured in the second mode.

\* \* \* \* \*

专利名称(译)	用于ECG信号采集的可穿戴设备		
公开(公告)号	<a href="#">US10368765</a>	公开(公告)日	2019-08-06
申请号	US15/613755	申请日	2017-01-18
[标]申请(专利权)人(译)	安徽华米信息科技有限公司 华米公司		
申请(专利权)人(译)	安徽HUAMI信息技术有限公司. HUAMI INC.		
当前申请(专利权)人(译)	安徽HUAMI信息技术有限公司. HUAMI INC.		
[标]发明人	HUANG WANG SU JIXIANG ZHAO YAJUN WANG FEI WANG YUANXIANG		
发明人	HUANG, WANG SU, JIXIANG ZHAO, YAJUN WANG, FEI WANG, YUANXIANG		
IPC分类号	A61B5/0404 A61B5/0402 A61B5/0416 A61B5/0408 A61B5/0432 A61B5/0468 A61B5/0452 A61B5/00 A61B5/11		
CPC分类号	A61B5/0404 A61B5/0416 A61B5/0452 A61B5/0468 A61B5/04085 A61B5/04087 A61B5/7267 A61B5 /04325 A61B5/6833 A61B5/0402 A61B5/1123 A61B5/6824 A61B5/6831 G16H50/70		
优先权	201610079901.3 2016-02-02 CN		
其他公开文献	US20170273584A1		
外部链接	<a href="#">Espacenet</a>		

摘要(译)

用于测量佩戴可穿戴设备的用户的ECG信号的方法，装置和可穿戴设备包括当以第一模式测量ECG信号时，通过ECG传感器从由第一ECG传感器电极形成的闭合电路接收ECG信号，第二ECG传感器电极，其中可穿戴设备包括可拆卸可穿戴设备的主体，连接部分和电极贴片，主体包括ECG传感器，第一ECG传感器电极和第二ECG传感器电极并且当以第二模式测量ECG信号时，ECG传感器从由电极贴片的电极形成的闭合电路接收ECG信号，其中ECG传感器在主体中并且主体连接到电极贴片。

