



(19) **United States**

(12) **Patent Application Publication**
Bleich et al.

(10) **Pub. No.: US 2018/0296157 A1**
(43) **Pub. Date: Oct. 18, 2018**

(54) **SYSTEMS AND METHODS FOR COORDINATING MUSCULOSKELETAL AND CARDIOVASCULAR HEMODYNAMICS**

A61B 5/0488 (2006.01)
A63B 22/02 (2006.01)
A63B 22/06 (2006.01)
A63B 24/00 (2006.01)

(71) Applicant: **Pulson, Inc.**, Palo Alto, CA (US)

(52) **U.S. Cl.**
CPC *A61B 5/486* (2013.01); *A61B 5/0205* (2013.01); *A61B 5/0295* (2013.01); *A61B 5/0261* (2013.01); *A61B 5/029* (2013.01); *A61B 5/0476* (2013.01); *A61B 5/021* (2013.01); *A61B 7/04* (2013.01); *A61B 5/0488* (2013.01); *A63B 22/02* (2013.01); *A63B 22/0605* (2013.01); *A63B 24/0062* (2013.01); *A61B 5/6803* (2013.01); *A61B 5/7246* (2013.01)

(72) Inventors: **Jeffery Lee Bleich**, Palo Alto, CA (US); **Paul David Mannheimer**, Los Altos, CA (US)

(21) Appl. No.: **16/015,636**

(22) Filed: **Jun. 22, 2018**

Related U.S. Application Data

(63) Continuation-in-part of application No. 15/515,118, filed on Mar. 28, 2017, filed as application No. PCT/US15/52326 on Sep. 25, 2015, Continuation-in-part of application No. 14/553,735, filed on Nov. 25, 2014, now abandoned.

(60) Provisional application No. 62/056,730, filed on Sep. 29, 2014.

Publication Classification

(51) **Int. Cl.**
A61B 5/00 (2006.01)
A61B 5/0205 (2006.01)
A61B 5/0295 (2006.01)
A61B 5/026 (2006.01)
A61B 5/029 (2006.01)
A61B 5/0476 (2006.01)
A61B 7/04 (2006.01)

(57) **ABSTRACT**

Described herein are systems and methods for favorably coordinating a timing relationship between a musculoskeletal activity cycle and a cardiac cycle of a user. A method may include repetitively detecting a signal that correlates to a blood volume in the user; determining an actual value of the signal that varies with the timing relationship; computing a trend of the actual value of the signal; and adjusting the movement guidance based on the trend of the actual value. A system may include a prompt device configured to provide recurrently a movement guidance to the user for guiding performance of the rhythmic musculoskeletal activity; a sensor configured to provide a signal that correlates to a blood volume in the user; and a processor configured to determine an actual value of the signal that varies with the timing relationship and to adjust the movement guidance based on the trend of the actual value.

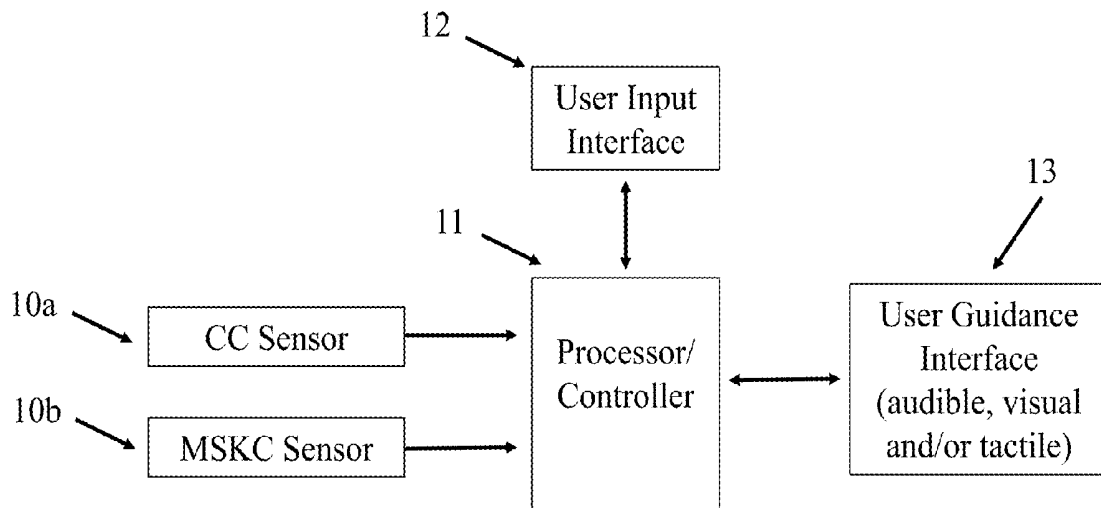

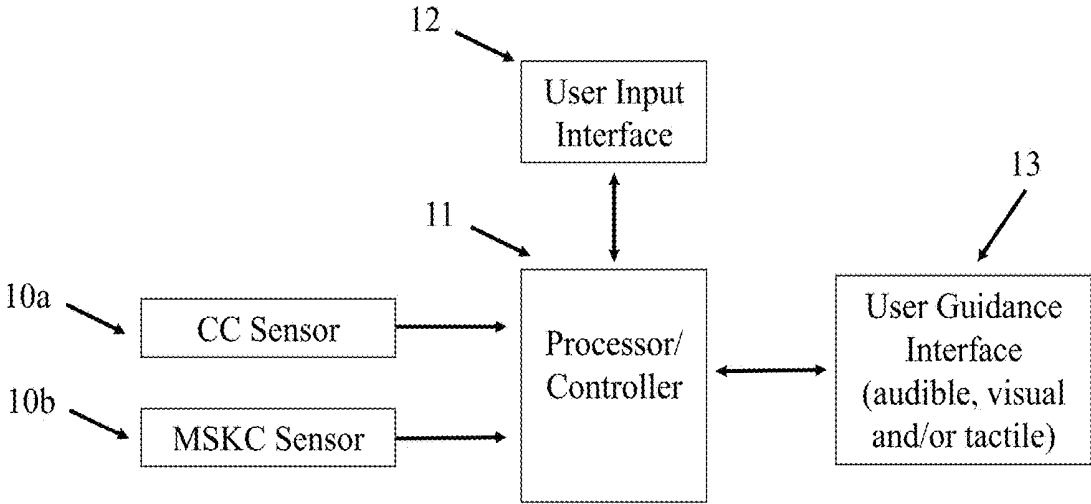

FIG. 1

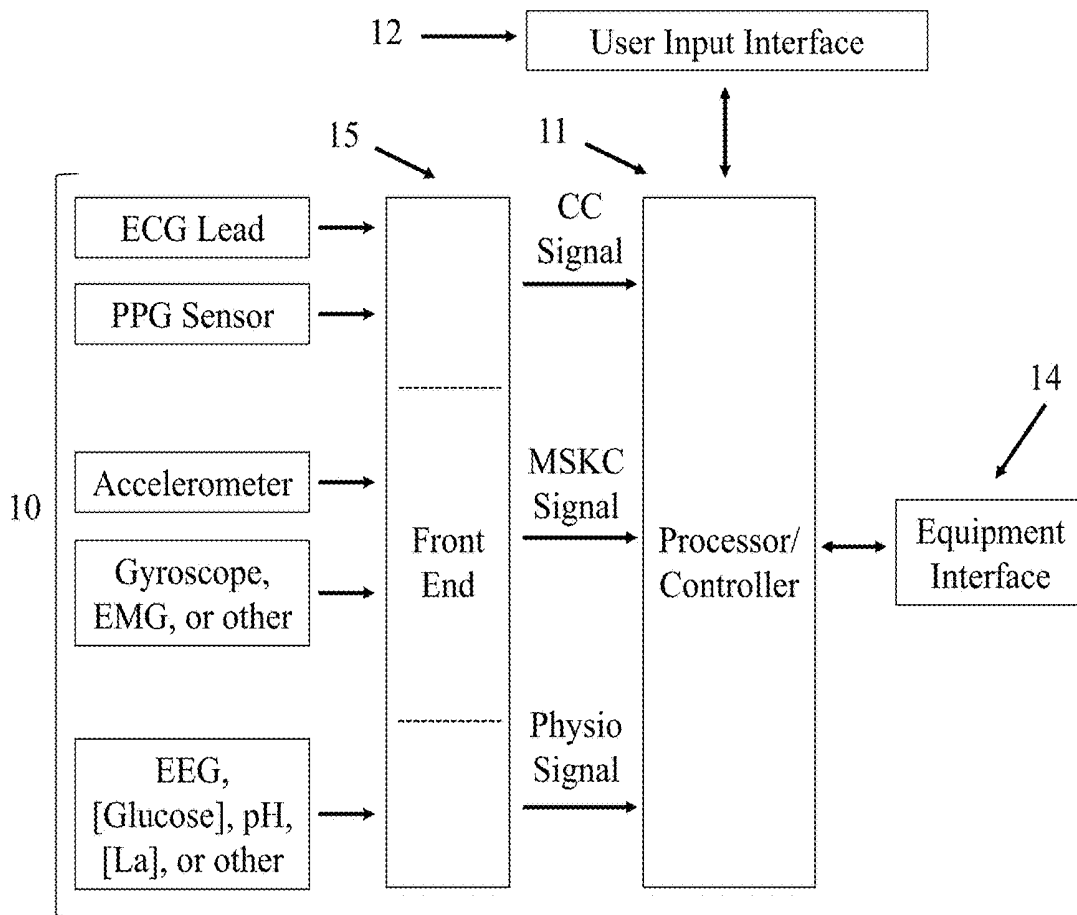

FIG. 2

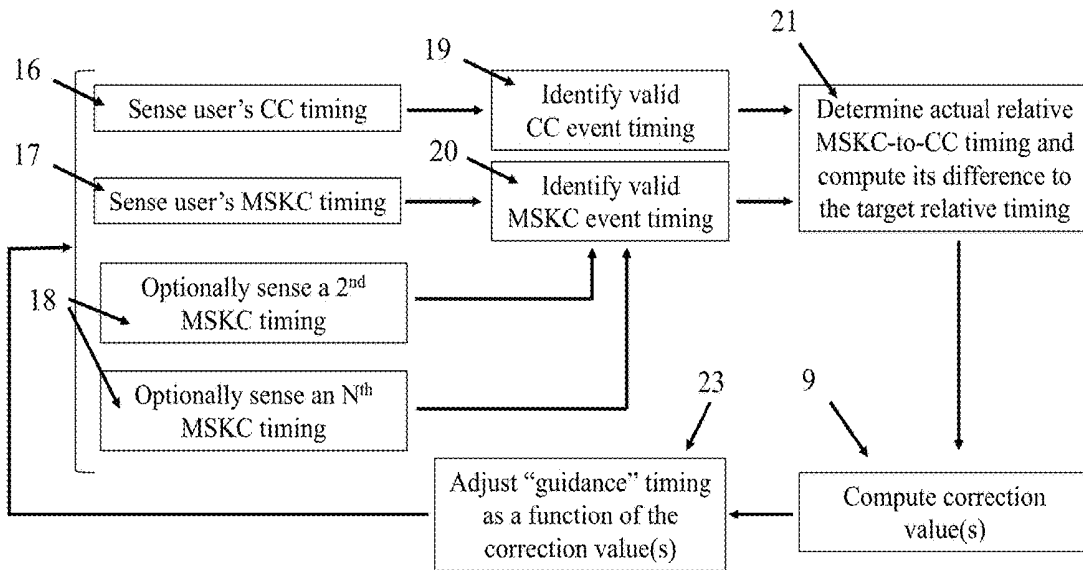

FIG. 3A

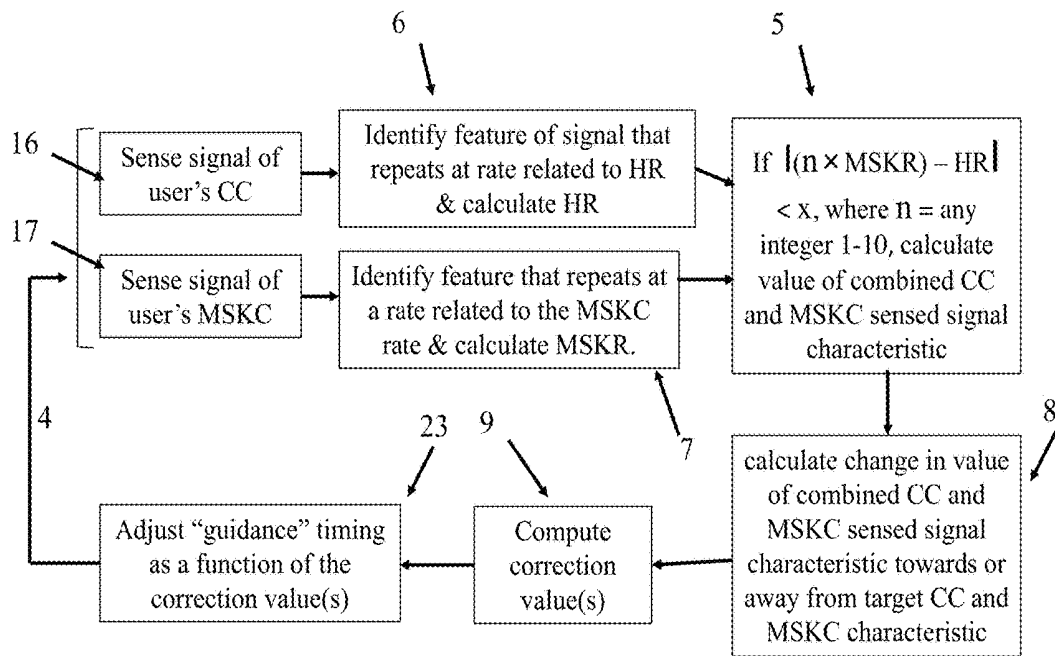

FIG. 3B

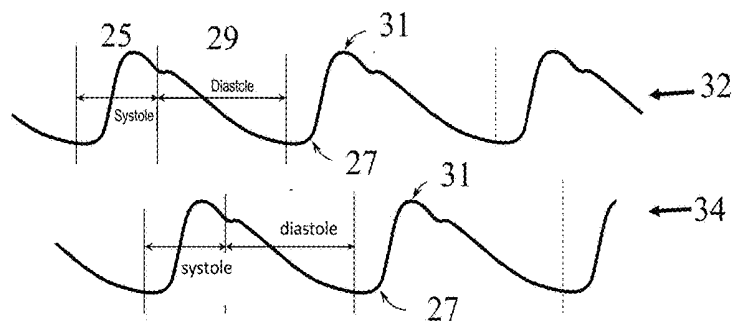

FIG. 4A

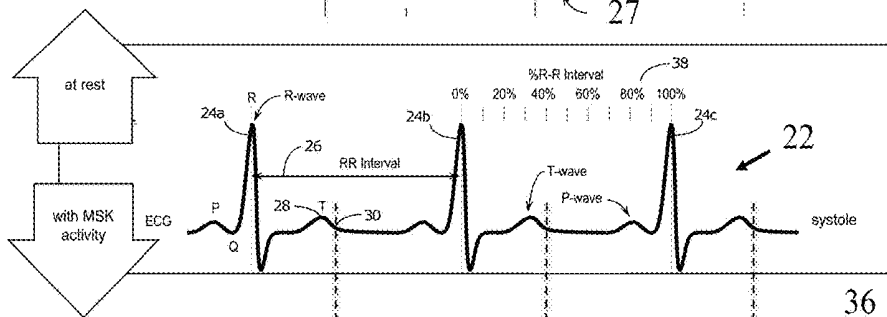

FIG. 4B

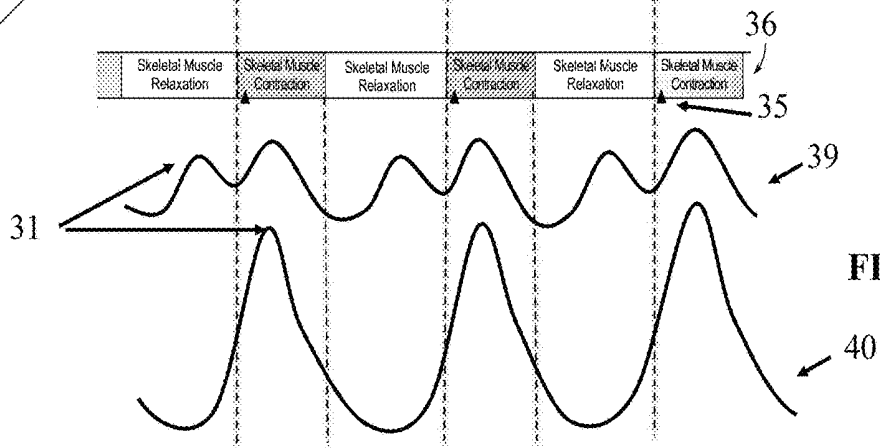

FIG. 4C

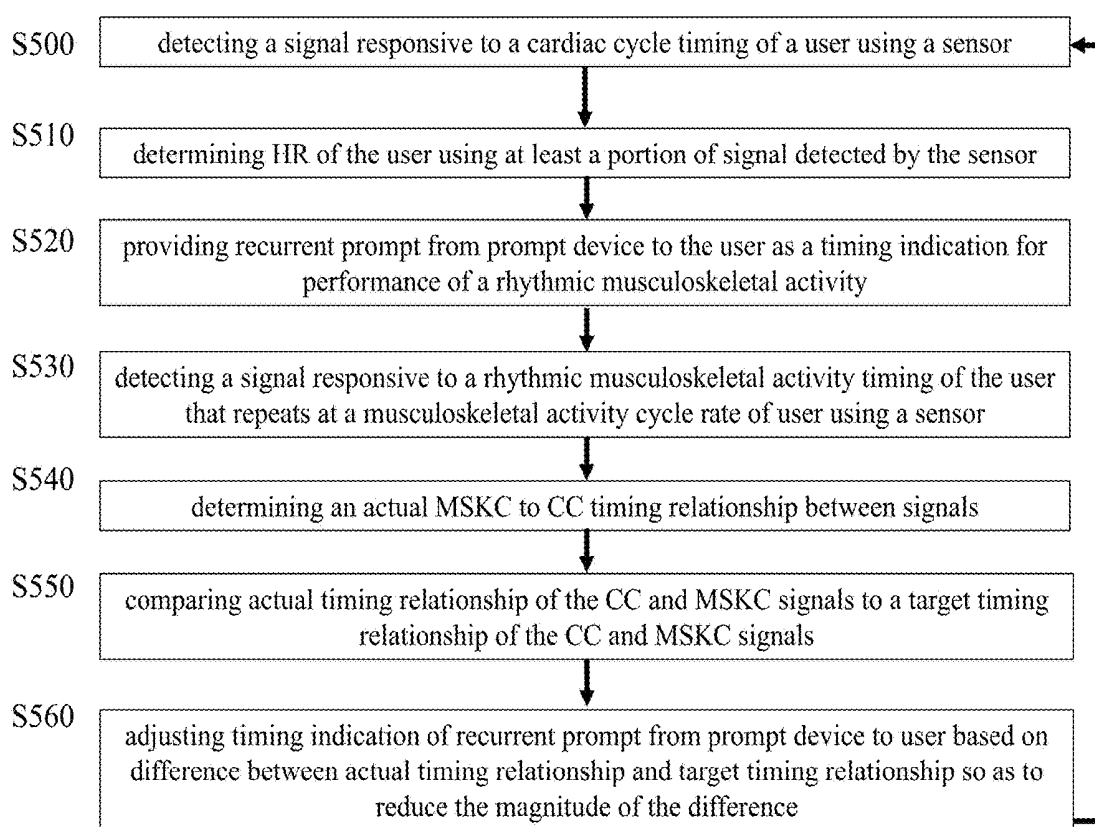

FIG. 5

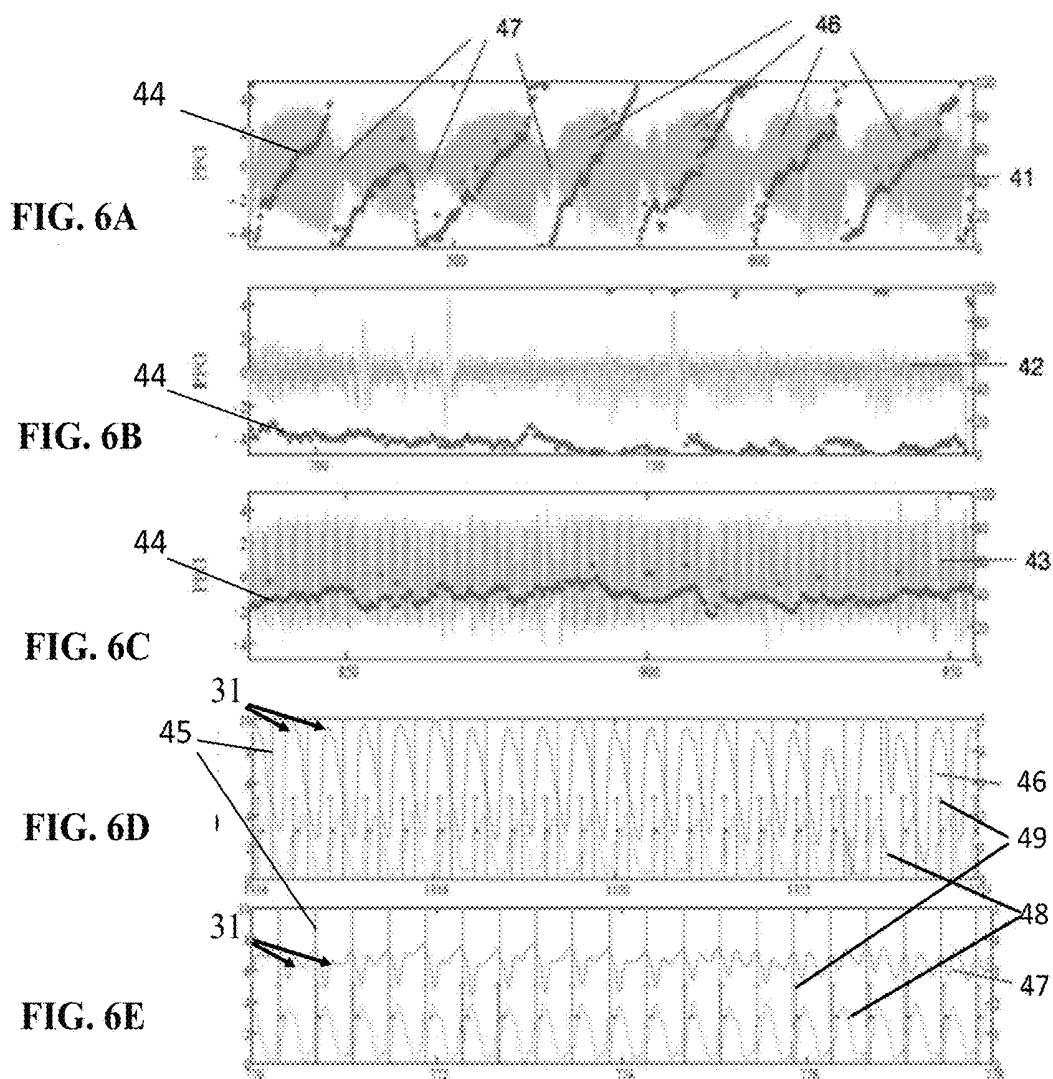

FIG. 6F

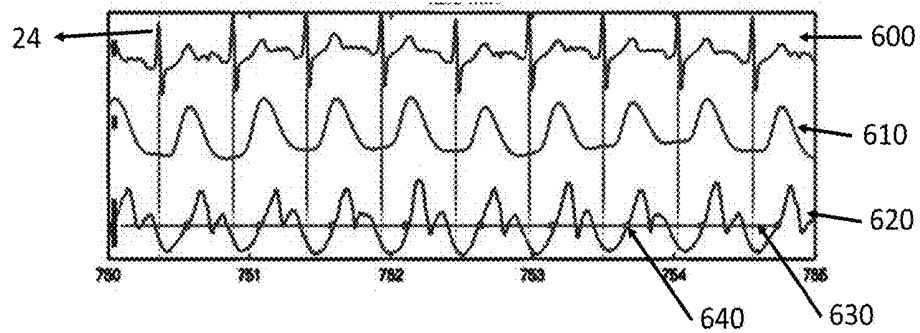
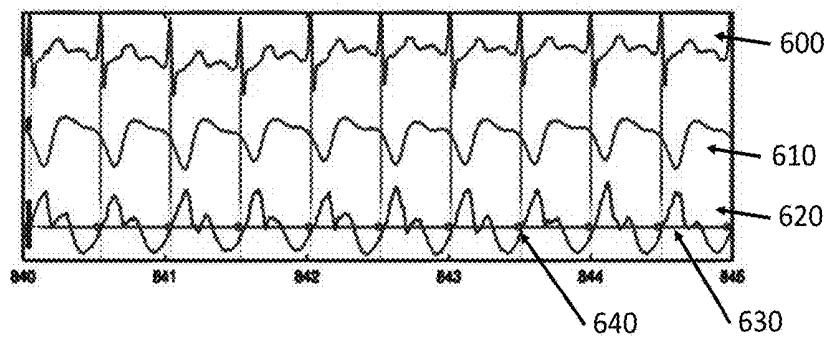

FIG. 6G



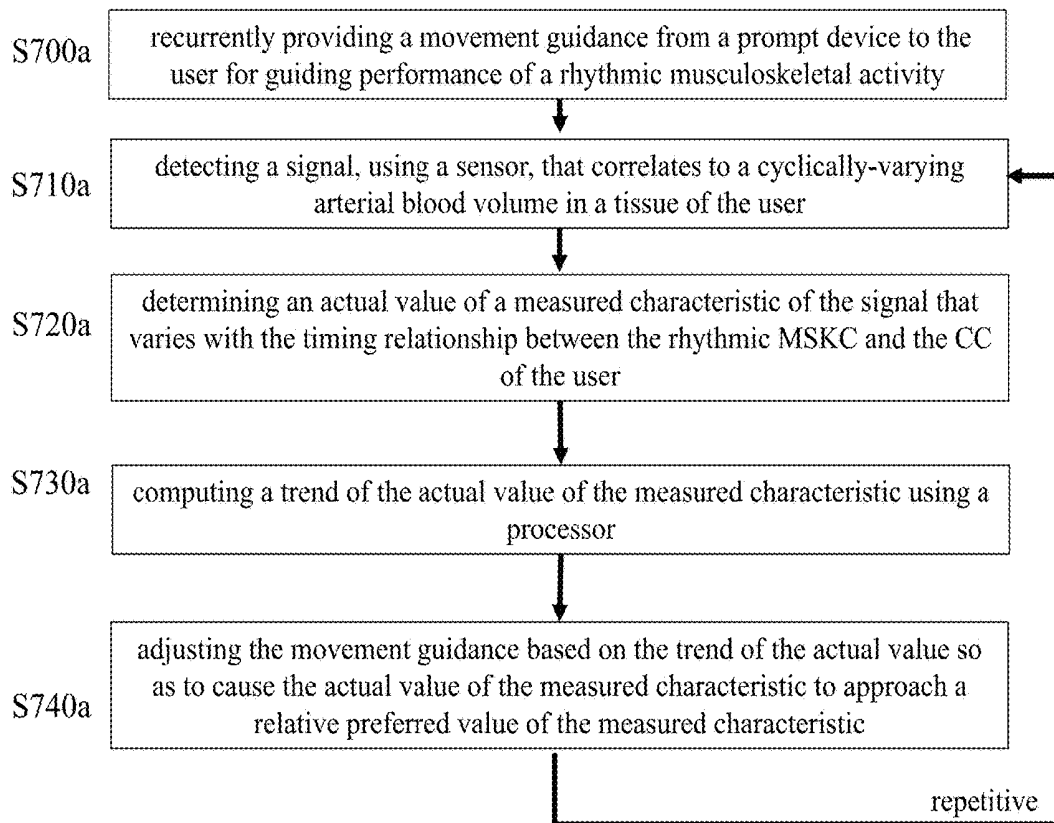

FIG. 7A

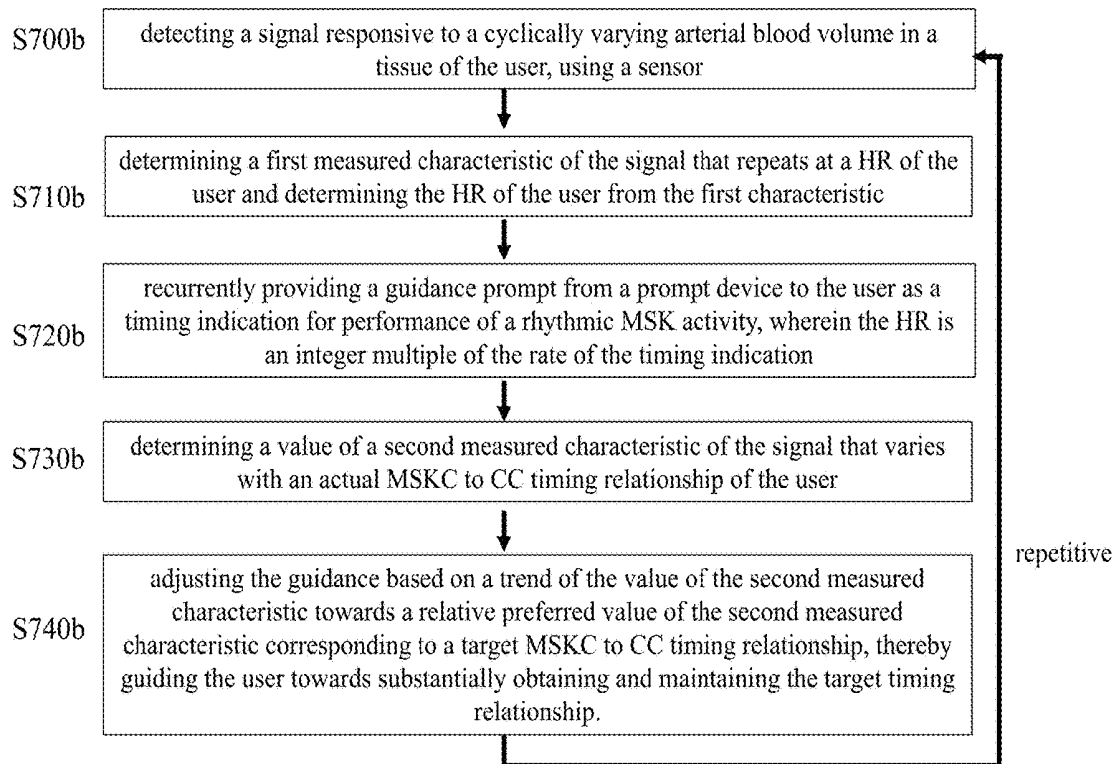

FIG. 7B

FIG. 8

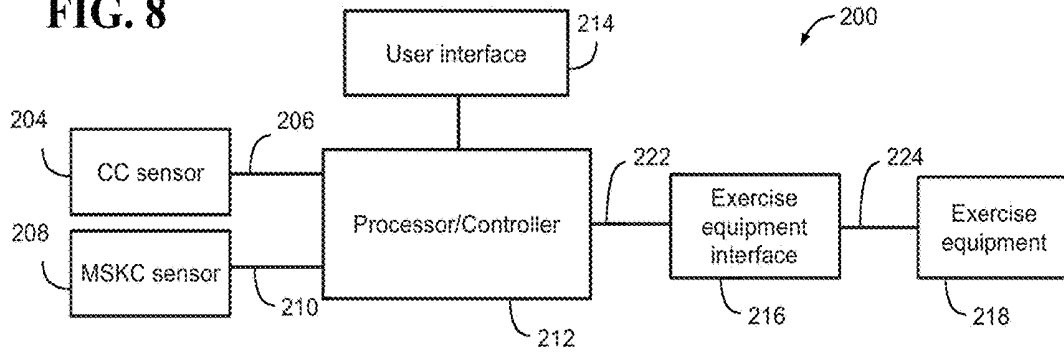
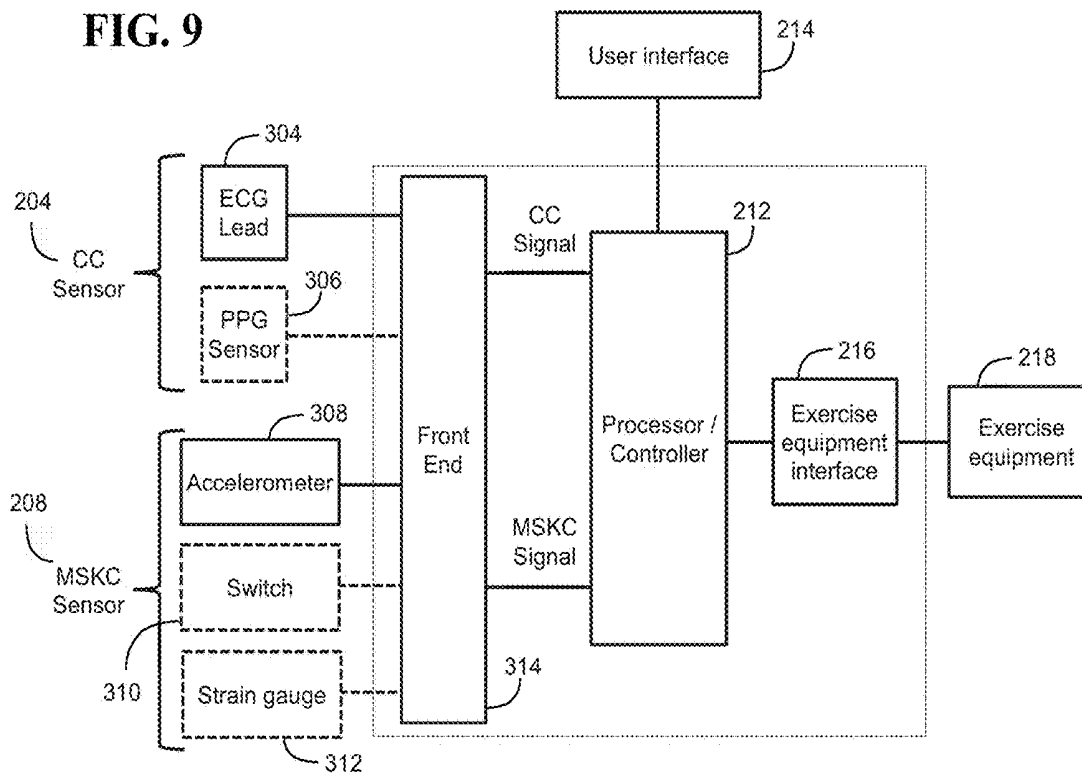

FIG. 9



(Dashed boxes indicate examples of alternative sensors, though is not intended to be limiting)

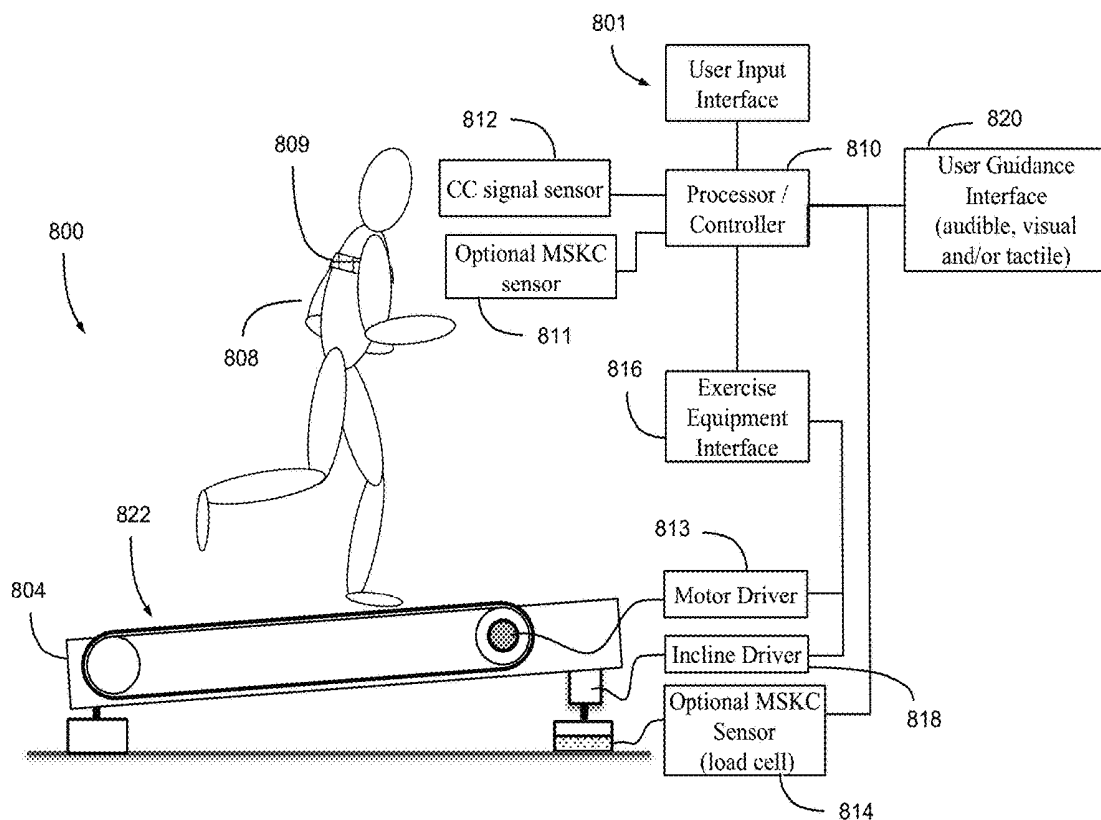
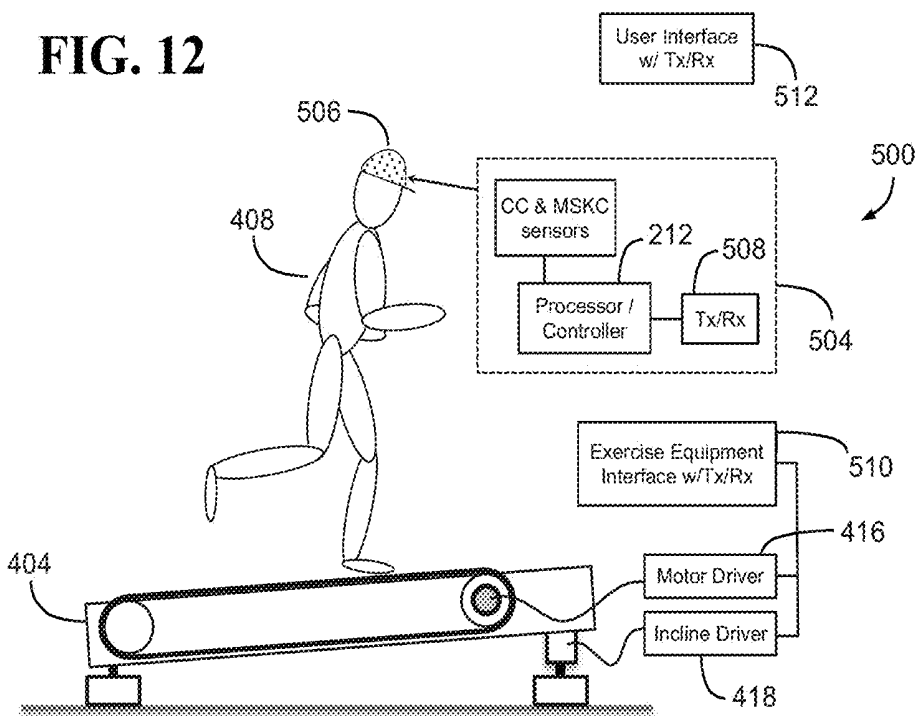
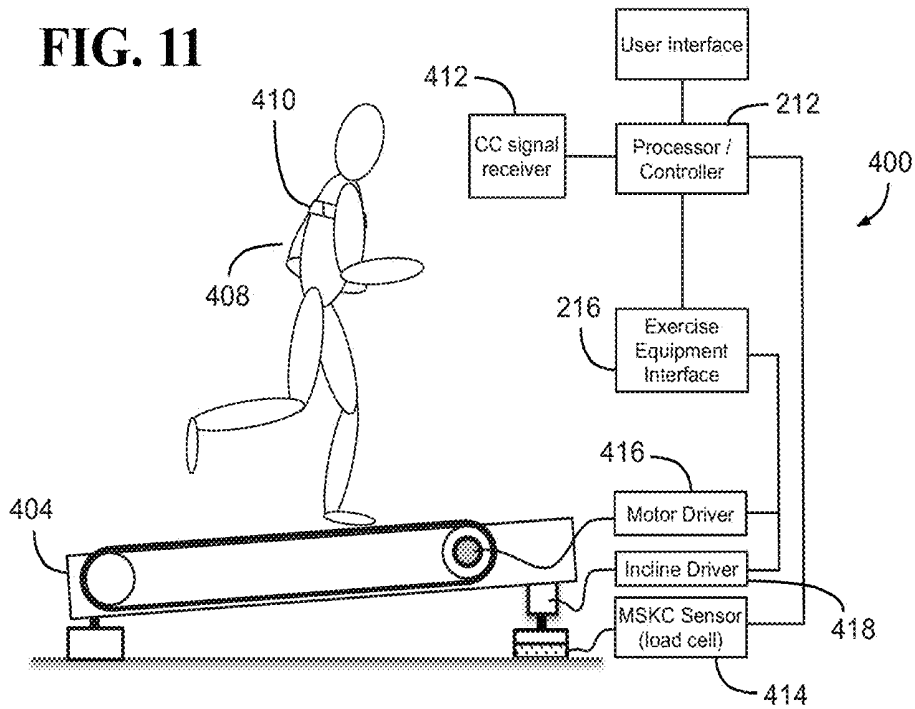

FIG. 10



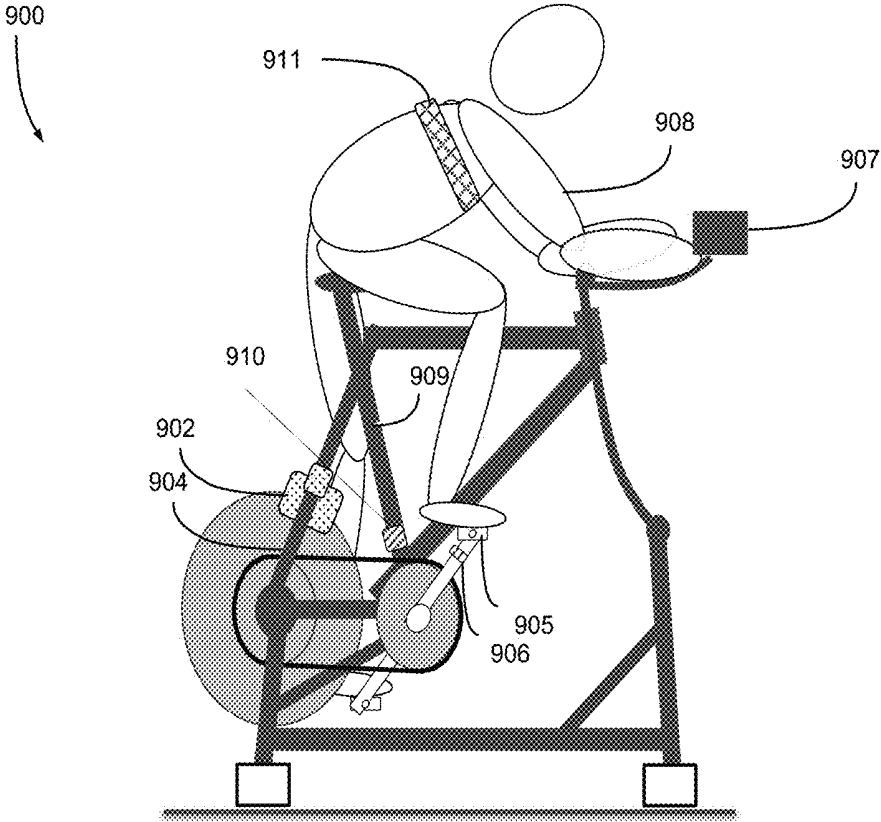

FIG. 13

FIG. 14

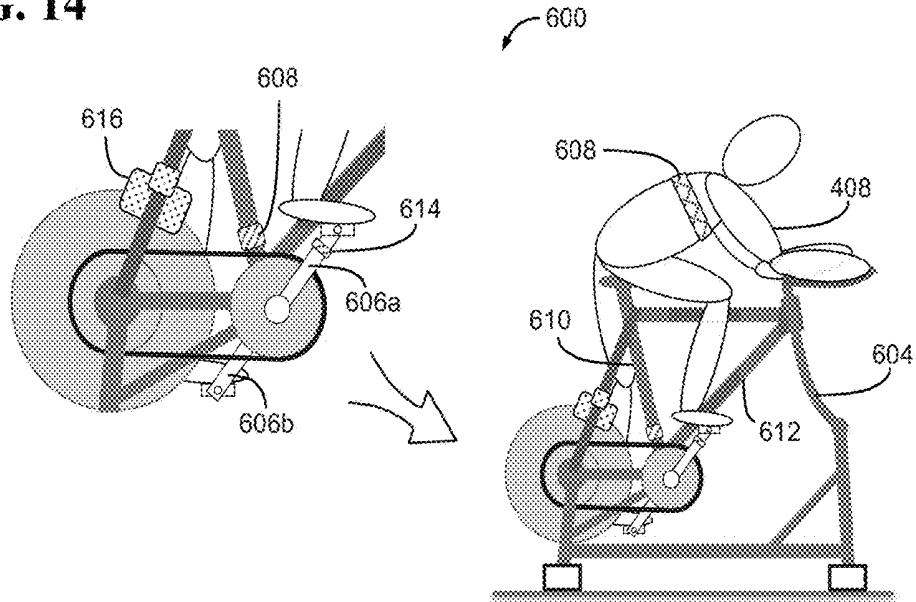
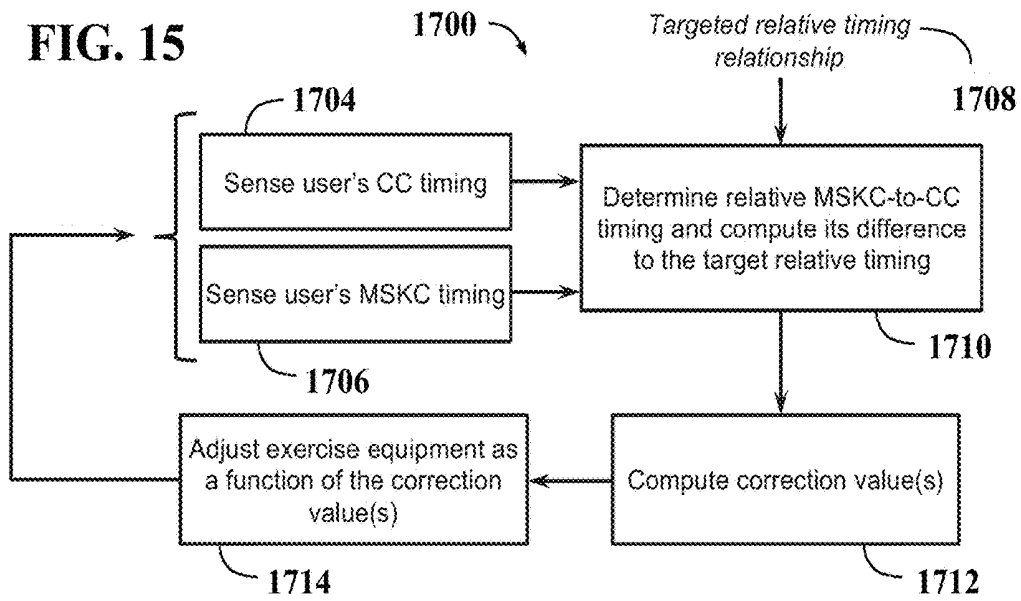

FIG. 15



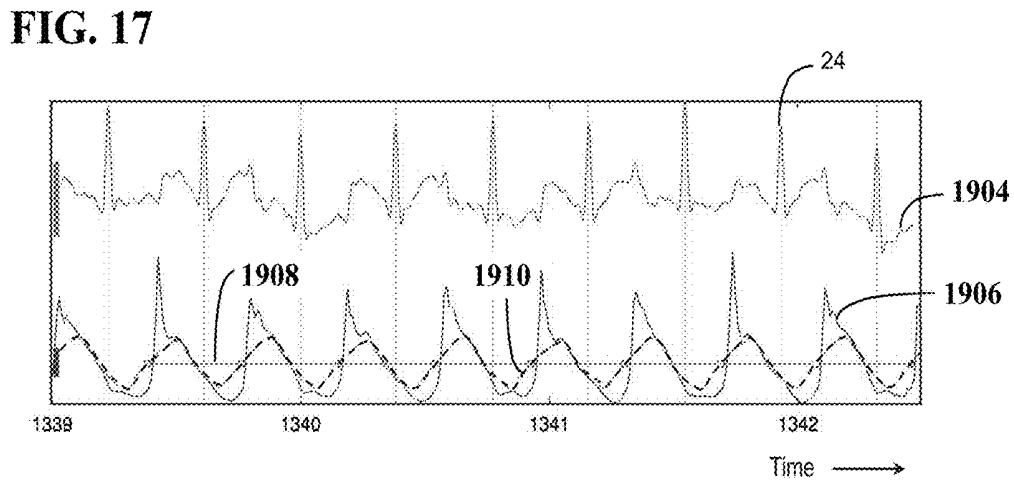
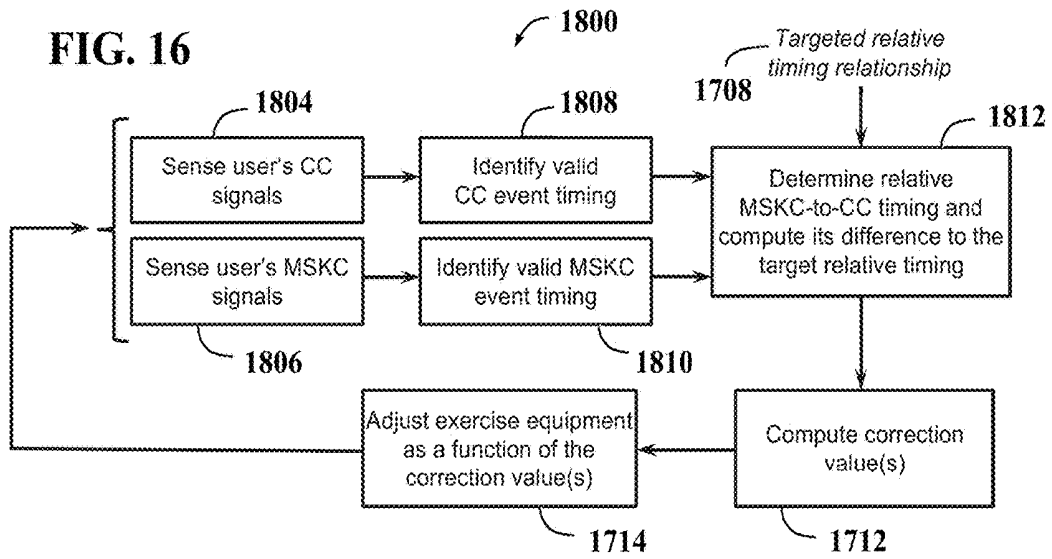

FIG. 18

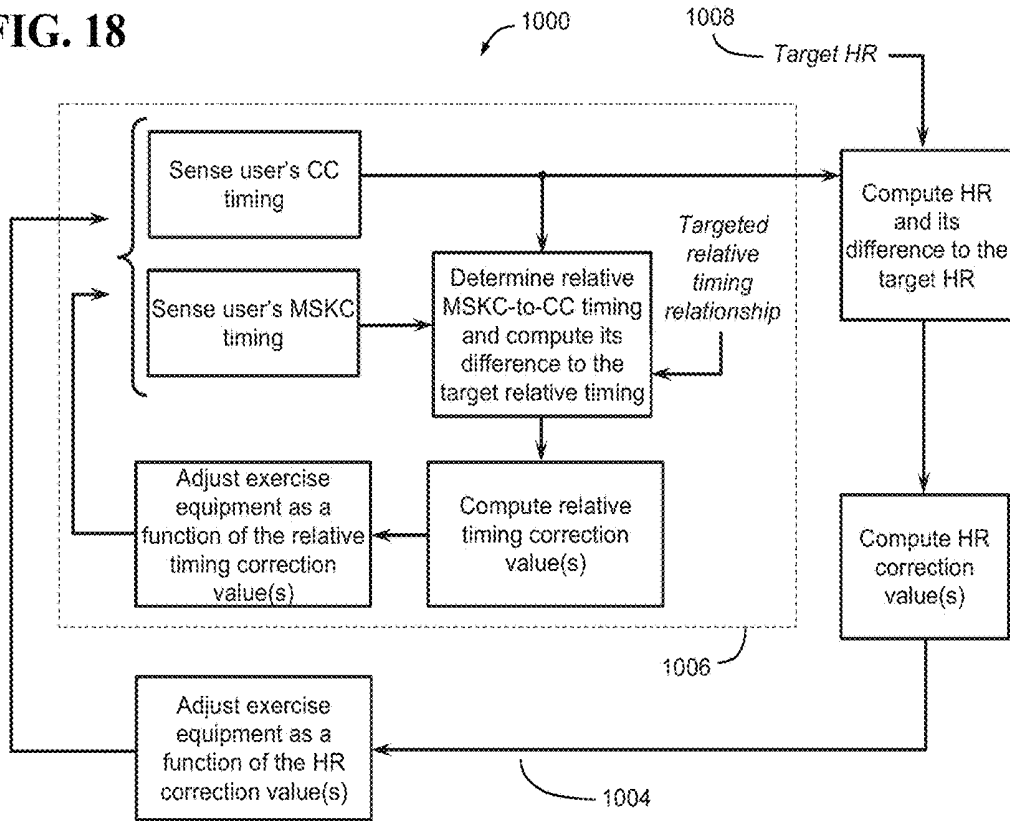
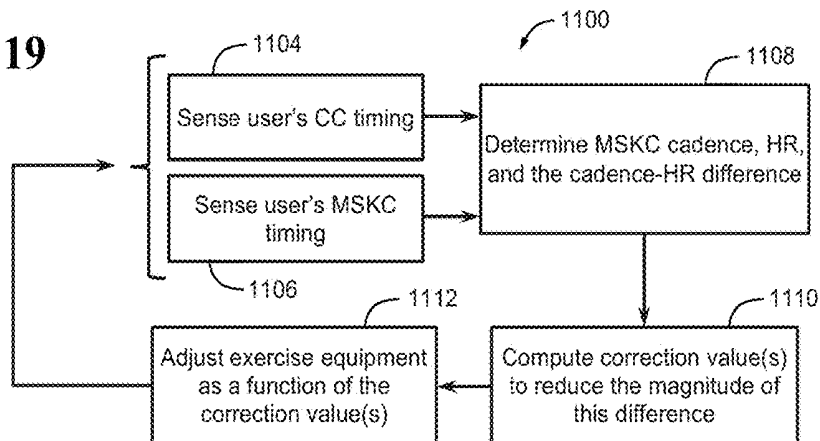

FIG. 19



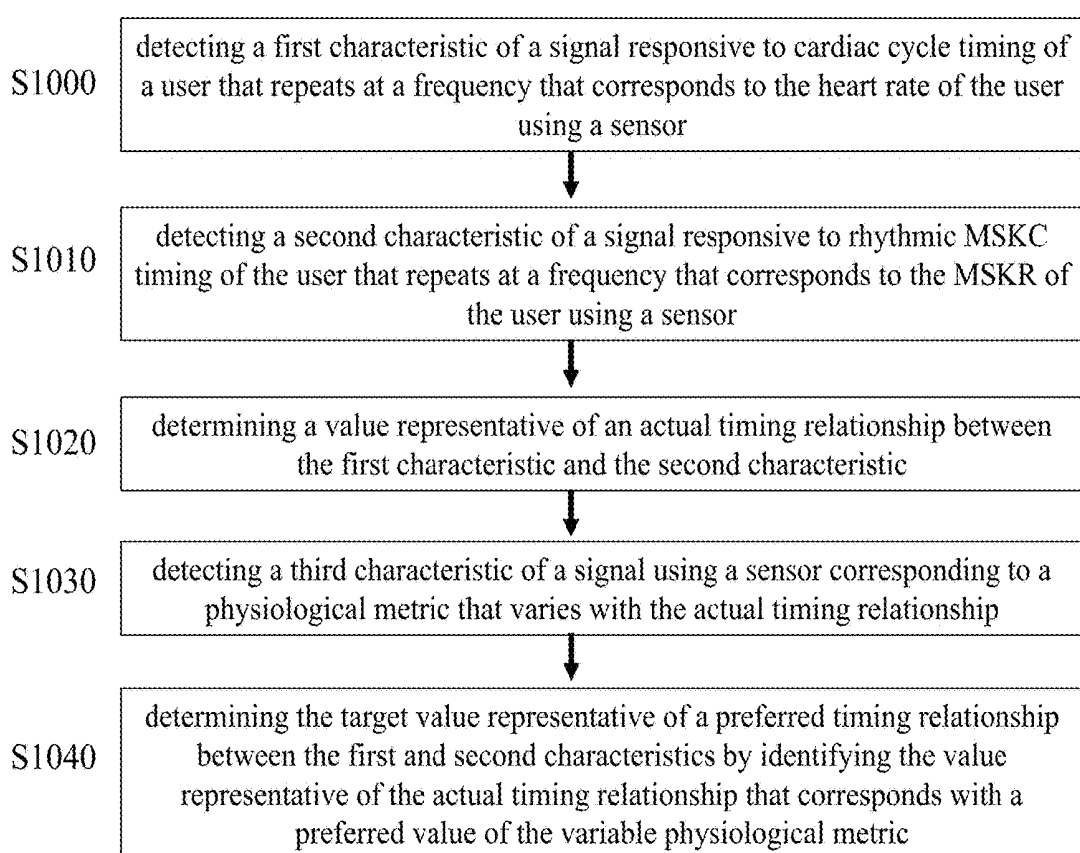

FIG. 20

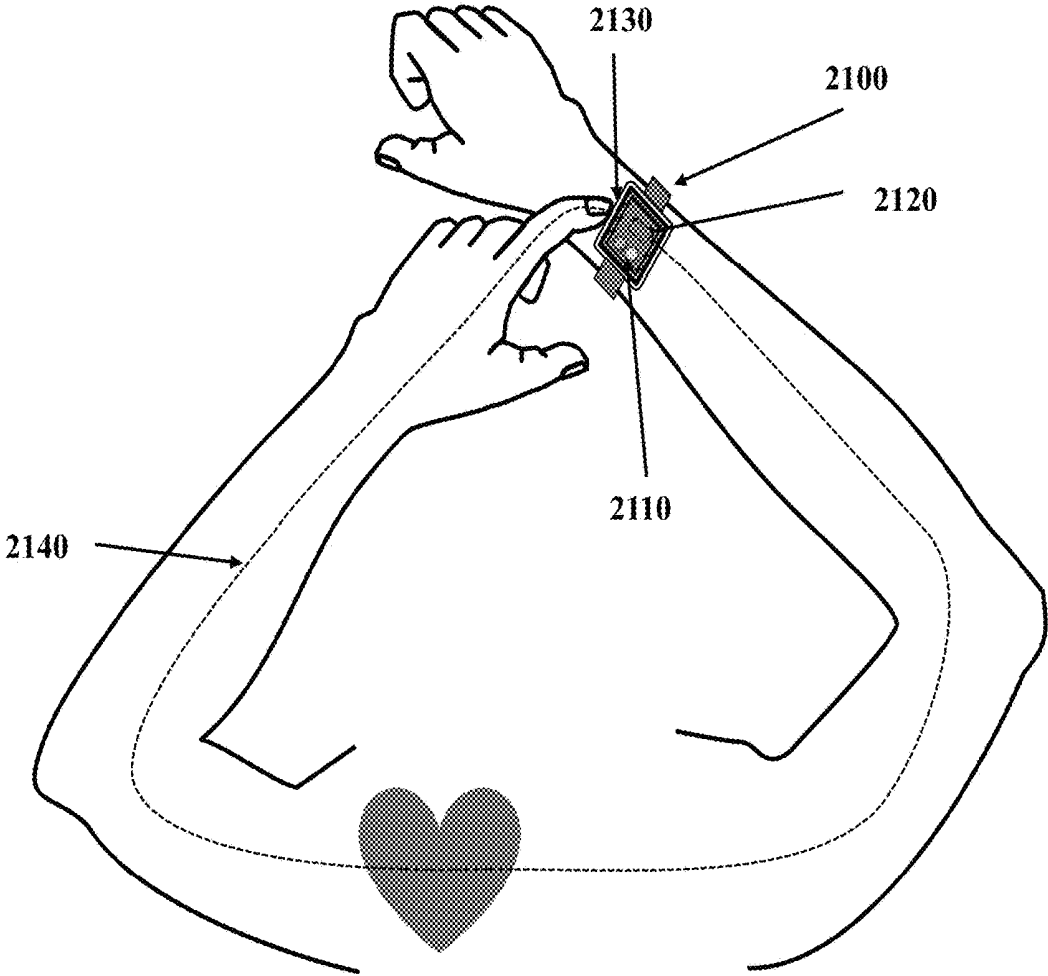

FIG. 21

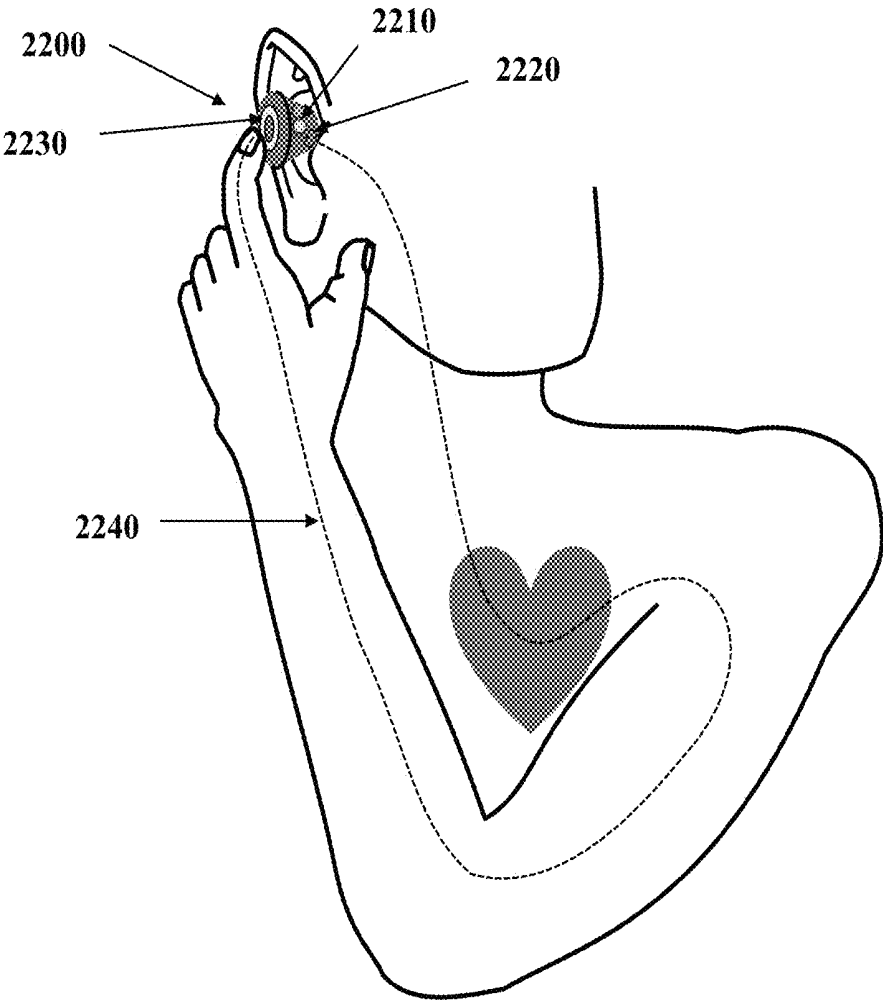

FIG. 22

**SYSTEMS AND METHODS FOR
COORDINATING MUSCULOSKELETAL AND
CARDIOVASCULAR HEMODYNAMICS**

**CROSS-REFERENCE TO RELATED
APPLICATIONS**

[0001] This application is a continuation-in-part of U.S. patent application Ser. No. 15/515,118, entitled “Coordinating Musculoskeletal and Cardiovascular Hemodynamics” and filed Mar. 28, 2017; which is the National Stage of International Patent Application No. PCT/US2015/052326, entitled “Coordinating Musculoskeletal and Cardiovascular Hemodynamics” and filed Sep. 25, 2015; which claims the priority benefit of U.S. Provisional Application No. 62/056,730, entitled “Coordinating Musculoskeletal and Cardiovascular Hemodynamics” and filed Sep. 29, 2014; the contents of each of which are herein incorporated by reference in their entirety.

[0002] This application is also a continuation-in-part of U.S. patent application Ser. No. 14/553,735, entitled “Systems and Methods for Coordinating Musculoskeletal and Cardiovascular or Cerebrovascular Hemodynamics” and filed Nov. 25, 2014, the contents of which are herein incorporated by reference in their entirety.

[0003] This application is related to U.S. patent application Ser. No. 13/589,073, entitled “System and Method for Reliably Coordinating Musculoskeletal and Cardiovascular Hemodynamics” and filed on Aug. 17, 2012, which claims the priority benefit of U.S. Provisional Patent Application Ser. No. 61/525,689, entitled “System and Method for Selectively Coordinating User Movement and Muscle Contraction with User Cardiac Pumping Cycle” and filed on Aug. 19, 2011, both of which are herein incorporated by reference in their entirety. This application is also related to U.S. patent application Ser. No. 14/216,960, entitled “Coordinating Musculoskeletal and Cardiovascular Hemodynamics” and filed on Mar. 17, 2014, which claims the priority benefit of U.S. provisional Patent Application Ser. No. 61/798,799, entitled “Systems and Methods for Reliably Coordinating Musculoskeletal and Cardiovascular Hemodynamics” and filed on Mar. 15, 2013, both of which are herein incorporated by reference in their entirety. This application is related to U.S. Provisional Patent Application Ser. No. 62/056,730, entitled “Coordinating Musculoskeletal and Cardiovascular Hemodynamics” and filed on Sep. 29, 2014, which is herein incorporated by reference in its entirety.

INCORPORATION BY REFERENCE

[0004] All publications and patent applications mentioned in this specification are herein incorporated by reference in their entirety, as if each individual publication or patent application was specifically and individually indicated to be incorporated by reference in its entirety.

COPYRIGHT NOTICE

[0005] A portion of the disclosure of this patent document contains material that is subject to copyright protection. The copyright owner has no objection to the facsimile reproduction by anyone of the patent document or the patent disclosure as it appears in the Patent and Trademark Office patent file or records, but otherwise reserves all copyright rights whatsoever.

TECHNICAL FIELD

[0006] This invention relates generally to the field of human physiology, and more specifically to new and useful methods, apparatuses, systems and computer program products for coordinating musculoskeletal and cardiovascular or cerebrovascular hemodynamics.

BACKGROUND

[0007] Blood is circulated through the body by the heart during its rhythmic pumping cycle, which consists of two distinct periods—systole and diastole. Heart muscle contracts to eject blood from the ventricles during the systolic period of each cardiac cycle (CC). Ejection of blood from the ventricles generates arterial blood pressure and flow adequate to deliver blood throughout the body. The blood transports oxygen, nutrients and metabolic products, removes carbon dioxide and waste, and facilitates critical physiological functions such as heat exchange. The heart subsequently relaxes during the diastolic period of the CC, when the atrial and ventricular chambers refill with blood in preparation for the heart’s next contraction.

[0008] Unlike the rest of the body, which receives most of its blood flow during the systolic portion of the arterial pressure cycle, contraction of the heart during systole generates high forces within the heart’s muscular walls, preventing blood from flowing through the heart muscle itself at that time. Therefore, the heart’s own arterial blood supply is delivered primarily during diastole, when the heart muscle is relaxing and the heart chambers are filling for the next contraction, while at the same time the lower residual blood pressure in the aorta pushes blood through the coronary arteries and into the myocardial muscle to supply the heart with its needed oxygen and nutrients.

[0009] In addition to the heart’s pumping function, the musculoskeletal (MSK) system also pumps arterial and venous blood throughout the body during physical activity in a couple of important ways. First, skeletal muscle contraction and relaxation cycles during rhythmic physical activities cause regular oscillations in peripheral arterial and venous blood pressure or flow due to intermittent compression of the vasculature that travels within, between, and adjacent to the skeletal muscles. Second, MSK movement can lead to periodic acceleration and deceleration of the intravascular volume of blood against gravity and inertia.

[0010] When rhythmic muscle contractions or MSK movements are favorably coordinated with the timing of the heart’s pump cycle, the MSK and cardiac pumping systems can augment one another to increase blood flow to and perfusion of important areas of the body with less pumping energy expended by the heart. This favorable coordination of these two pumping systems can be referred to as “musculoskeletal counterpulsation” (MCP). During MCP, maximum rhythmic MSK-induced blood pumping consistently increases central arterial blood pressure when the heart is relaxing and refilling between contractions (i.e. during diastole), and the maximum cardiac induced pumping (systole) consistently occurs between MSK induced maximal central arterial pressure events. On the other hand, when rhythmic muscle contractions and MSK movements occur with uncoordinated, or worse, unfavorably coordinated timing, blood flow and perfusion are decreased along with a concurrent decrease in pumping efficiencies. Unfavorable coordination occurs, for example, when the cardiac and MSK systems

consistently pump blood maximally into the central circulation at substantially the same time during rhythmic physical activity. This unfavorable coordination of the two pumping systems can be referred to as “inverse musculoskeletal counterpulsation” (iMCP).

[0011] Typically, when individuals walk, run, bicycle, or participate in any rhythmic physical activity, most experience favorable coordination between MSK blood pumping and CC blood pumping only intermittently. Even when an individual’s heart rate (HR) and MSK activity cycle rate (MSKR) happen to be substantially equal, the respective timing of the two pumping systems may result in favorable or unfavorable coordination, or somewhere in between. A certain degree of “cardio-locomotor synchronization” can occur during rhythmic physical activity, in which the timing of an individual’s MSK pump cycle relative to the heart’s pump cycle tends, statistically, to naturally favor MCP. However, when such synchrony does occur, it is usually only a temporary phenomenon since HR and/or MSKR can change as environmental factors vary (e.g., running in hilly terrain or variable wind) or with any of several physical changes, such as alterations in effort, speed, hydration, temperature, catecholamine levels, or fatigue.

[0012] The benefits of favorable coordination between MSK movements and the heart’s pump cycle can include improved perfusion and oxygenation of cardiac and peripheral skeletal muscle and possibly other tissues; decreased HR due to increased cardiac preload and stroke volume; decreased systolic blood pressure and pulse pressure; decreased required respiratory effort to meet decreased oxygen demands; and reduced muscle fatigue due to improved skeletal muscle perfusion. These benefits can potentially lead to increased physiological efficiency, decreased myocardial stress, increased aerobic energy production, improved aerobic fat metabolism, enhanced individual performance, and a potential increase in the health benefits and safety of rhythmic physical activity. Conversely, unfavorable coordination between MSK movements and the heart’s pump cycle can lead to the opposite of all of these effects.

[0013] Some of the general approaches that we have described for favorably coordinating MSKC and CC timing during rhythmic physical activity include (1) the provision of adaptive real-time MSKC timing prompts to a user; (2) automated means of adjusting exercise equipment settings in order to adaptively modify a user’s MSKC timing; and (3) automated means of adjusting artificial cardiac pacemaker systems to adaptively adjust the timing of the CC relative to the MSKC of the user. Each of these general approaches may require the identification and use of sensed physiological metrics to assist with identifying a target timing relationship between the MSKC and CC of the user, measuring physiological impacts of the timing relationship, and tracking progress in favorably influencing physiology over time.

[0014] The methods and systems described below are for guiding a user to obtain and maintain favorable coordination of MSKC and CC hemodynamics, and more directly, to achieve or maintain system calibration, to increase the accuracy of identifying, achieving, and maintaining target pump timing relationships, and/or to track the effectiveness of achieving physiological benefit during rhythmic physical activity.

SUMMARY

[0015] Described herein are methods for guiding a user to a target rhythmic musculoskeletal cycle activity (MSKC) to cardiac cycle (CC) timing relationship. In general, the methods may include detecting a first signal responsive to the timing of the CC of a user using a first sensor; determining the heart rate (HR) of the user using at least a portion of the first signal detected by the first sensor using a first processor; providing a recurrent prompt from a prompt device to the user as a timing indication for performance of a rhythmic musculoskeletal activity; detecting a second signal responsive to the rhythmic musculoskeletal activity timing of the user that repeats at an MSKR of the user using a second sensor; determining an actual MSKC to CC timing relationship between the first signal and the second signal using the first processor; comparing the actual timing relationship of the first signal and the second signal to a target MSKC to CC timing relationship; and adjusting the timing indication of the recurrent prompt from the prompt device to the user based on a difference between the actual timing relationship and the target timing relationship, so as to reduce the magnitude of the difference.

[0016] In some embodiments, the target timing relationship is provided by the first processor or a second processor. In some embodiments, the timing indication guides the user to a musculoskeletal activity cycle rate (MSKR). In some embodiments, the HR of the user is substantially an integer multiple of the MSKR. In some embodiments, the recurrent prompt repeats at a prompt rate such that the HR is substantially an integer multiple of said prompt rate. In some embodiments, adjusting the timing indication of the recurrent prompt from the prompt device includes adjusting the prompt rate. In some embodiments, the recurrent prompt is an audible prompt that includes a beat of a musical track. In some embodiments, a volume of the beat of the musical track that includes the recurrent prompt is controlled separately from a volume of a rest of the musical track based on a user setup configuration, a program setup configuration, a consistency of the user in stepping to the recurrent prompt, and/or an accuracy of the user stepping at the timing indication. In some embodiments, the first sensor signal includes at least one of an electrocardiogram (ECG) and a plethysmogram. In some embodiments, the second sensor includes an accelerometer, an electromyographic sensor, a pressure sensor, a switch, a camera, a gyroscope, a proximity sensor, and/or a plethysmographic sensor.

[0017] In some embodiments, detecting the first signal includes identifying instances of one or more features of the first signal that occur once per CC. In some embodiments, the features correspond to one or more of an ECG R-wave, an ECG T-wave, an end of the ECG T-wave, a peak of a cardiovascular systolic pressure, a nadir of a diastolic cardiovascular pressure, and a transition point in a cardiovascular pressure of the user. In some embodiments, the method further includes determining the MSKR of the user, using the first processor or the second processor, based on the second signal detected by the second sensor.

[0018] Described herein are methods for determining a target MSKC to CC timing relationship. In general, the methods may include detecting a first characteristic of a signal responsive to a CC timing of a user that repeats at a frequency that corresponds to a HR of the user using a first sensor; detecting a second characteristic of a signal responsive to a rhythmic MSKC timing of the user that repeats at

a frequency that corresponds to the MSKR of the user using the first sensor or a second sensor; determining a value representative of an actual timing relationship between the first characteristic and the second characteristic using a first processor; detecting a third characteristic of a signal using the first, the second, or a third sensor corresponding to a physiological metric that varies with the actual timing relationship between the first and second characteristics; and determining a target value representative of a preferred timing relationship between the first and second characteristics by identifying the value representative of the actual timing relationship that corresponds with a preferred value of the variable physiological metric, using the first processor or a second processor.

[0019] In some embodiments, the method further includes providing a recurrent prompt from a prompt device at a prompt rate to the user as a timing indication for performance of the rhythmic MSKC. In some embodiments, the prompt device is controlled by the first processor or the second processor. Further, in some embodiments, the HR of the user is substantially an integer multiple of the prompt rate. In some embodiments, the prompt rate is provided to guide the user to vary the MSKC timing relative to the CC timing. In some embodiments, the target value representative of the preferred timing relationship is naturally achieved by the user. In some embodiments, the prompt device prompts the user to maintain the naturally achieved preferred timing relationship. In some embodiments, the prompt device is configured by the first or second processor to controllably guide the user to at least two different actual timing relationships. In some embodiments, at least two of the first, second, or third characteristics are aspects of a first signal from the first sensor. In some embodiments, the at least one of the first, second or third characteristics includes a Fourier transform. In some embodiments, the value representative of an actual timing relationship is determined by using a cross correlation between the first characteristic from the first sensor and the second characteristic from the second sensor. In some embodiments, the first characteristic and the second characteristic are derived from independent first and second signals from the first and second sensors, respectively. In some embodiments, the physiological metric includes the HR, a tissue pH, a tissue lactic acid level, a respiratory volume, a respiratory exchange ratio, an oxygen consumption, or a CO₂ production of the user.

[0020] In some embodiments, the method further includes prompting an adjustment of the cadence of the user to guide the user towards the target relative timing relationship. In some embodiments, the method further includes guiding the user to the HR and a MSKR, such that an absolute difference between the two rates is between 0.25 and 5 per minute. In some embodiments, the preferred value of the variable physiological metric is a most commonly occurring actual timing relationship. In some embodiments, the user achieves the target timing relationship without prompting when the HR and the MSKR are approximately equal. In some embodiments, the preferred value of the variable physiological metric is a most commonly occurring actual timing relationship. In some embodiments, the first sensor technology includes photoplethysmography, impedance plethysmography, laser-Doppler blood flow, acoustic sensing, or arterial tonometry. In some embodiments, the preferred value of the physiological metric is a lowest average HR of the user.

[0021] Described herein are methods for favorably coordinating a timing relationship between an MSKC of a rhythmic musculoskeletal activity of a user and a CC of the user. In general, the methods may include repetitively detecting a signal responsive to cyclically-varying arterial blood volume in a tissue of the user, using a sensor; determining a first measured characteristic of the signal that repeats at a HR of the user and determining the HR of the user from the first characteristic; recurrently providing a guidance prompt from a prompt device to the user as a timing indication for performance of a rhythmic MSK activity, determining a value of a second measured characteristic of the signal that varies with an actual MSKC to CC timing relationship of the user; and adjusting the guidance based on a trend of the value of the second measured characteristic towards a relative preferred value of the second measured characteristic corresponding to a target MSKC to CC timing relationship, thereby guiding the user towards substantially obtaining and maintaining the target MSKC to CC timing relationship. In some embodiments, the HR is an integer multiple of the rate of the timing indication.

[0022] Described herein are methods for favorably coordinating a timing relationship between an MSKC of a rhythmic musculoskeletal activity of a user and a CC of the user. In general, the methods may include recurrently providing a movement guidance from a prompt device to the user for guiding performance of a rhythmic musculoskeletal activity; and, repetitively, detecting a signal, using a sensor, that correlates to a cyclically-varying arterial blood volume in a tissue of the user; determining an actual value of a measured characteristic of the signal that varies with the timing relationship between the MSKC and the CC of the user, using a processor; and computing a trend of the actual value of the measured characteristic using a processor; and adjusting the movement guidance based on the trend of the actual value so as to cause the actual value of the measured characteristic to approach a relative preferred value of the measured characteristic.

[0023] In some embodiments, the movement guidance includes at least one of a recurrent audible, visual, or tactile prompt. In some embodiments, the detecting step includes using as the sensor technology photoplethysmography, impedance plethysmography, laser-Doppler blood flow, acoustic sensing, or arterial tonometry. In some embodiments, the measured characteristic of the signal that varies with the timing relationship between the MSKC and the CC of the user includes at least one of a pulse amplitude, a measure of relative peak to valley signal waveform curvature, a measure of signal waveform peak curvature, a measure of signal waveform valley curvature, a measure of signal waveform complexity, and a measure of an asymmetry of the signal waveform. In some embodiments, the relative preferred value of the measured characteristic is a threshold crossing of an increasing trend, a threshold crossing of a decreasing trend, a local maximum, or a local minimum of the trend of the actual value of the measured characteristic. In some embodiments, a heart rate of the user is substantially an integer multiple of the prompt rate.

[0024] In some embodiments, the method further includes detecting, using one or more sensors, signals that correlate to a heart rate of the user and a musculoskeletal activity cycle rate (MSKR) of the user; determining, using the processor, the heart rate of the user and an MSKR of the user by processing the one or more signals; specifying a maxi-

mum allowable absolute difference between the heart rate and the MSKR; and executing, using the processor, steps of paragraph [0012] only when an absolute value of a difference between the MSKR and heart rate is less than, or less than or equal to, a specified allowable difference.

[0025] In some embodiments, the method further includes specifying a target MSKR; and recurrently providing a prompt from the prompt device when the absolute value of the difference between the MSKR and the target MSKR is greater, or greater than or equal to, the specified allowable difference, the prompt repeating at a prompt rate.

[0026] In some embodiments, the target MSKR is an integer multiple of the prompt rate. In some embodiments, the measured characteristic of the signal is computed using a combination of two or more unique characteristics of the signal that vary with the timing relationship between the MSKC and the CC of the user. In some embodiments, the method further includes detecting with the sensor a second signal that correlates to the HR or the MSKR of the user. In some embodiments, the method further includes detecting with a second sensor signals that correlate to the HR or the MSKR of the user. In some embodiments, the target cadence equals a target heart rate of the user. In some embodiments, the movement guidance includes instructing the user in at least one of an MSK activity timing and an MSK activity effort. In some embodiments, instructing the user in the MSK activity effort includes providing movement guidance on stride length during running or walking, gear use while riding a bicycle, resistance, MSKC movement distance, incline using exercise equipment, or stroke length during rowing or swimming. In some embodiments, instructing the user in the MSK activity timing includes providing an MSKC prompt at a prompt rate to guide the user to an MSKR that is an integer multiple of the prompt rate.

[0027] In some embodiments, the method further includes a calibration process, said calibration process including detecting a second characteristic of at least one of the signal and one or more additional signals corresponding to a physiological metric that varies with the timing relationship between the MSKC and the CC of the user, using the sensor or one or more additional sensors; and determining the relative preferred value of the measured characteristic as a relative value of the trend that corresponds with a preferred value of the physiological metric.

[0028] In some embodiments, the physiological metric includes a measure of heart rate, minute ventilation, blood pressure, blood flow, cardiac output, electrical brain activity, oxygen consumption, tissue pH, tissue lactic acid level, or CO₂ production. In some embodiments, the relative preferred value is a target behavior of the trend of the value of the measured characteristic and includes further adjusting the guidance based on a difference between trend of the actual value of the measured characteristic and the relative preferred value of the measured characteristic. In some embodiments, the recurrent guidance guides the user towards substantially obtaining and maintaining the relative preferred value of the measured characteristic.

[0029] In some embodiments, the relative preferred value is a target value of the measured characteristic including further adjusting the guidance based on a difference between the actual value of the measured characteristic and the relative preferred value of the measured characteristic. In some embodiments, the target value corresponds to the target timing relationship between the MSKC and the CC of

the user. In some embodiments, the recurrent guidance guides the user towards substantially obtaining and maintaining the relative preferred value of the measured characteristic.

[0030] Described herein are systems for favorably coordinating a timing relationship between an MSKC of a rhythmic musculoskeletal activity of a user with a CC of the user. In general, the system may include a prompt device, such that the prompt device is configured to provide recurrently a movement guidance to the user for guiding performance of the rhythmic musculoskeletal activity. In general, the system may include a sensor, such that the sensor is configured to provide a signal that correlates to a cyclically-varying arterial blood volume in a tissue of the user. In general, the system may include a processor, coupled to the prompt device and the sensor, such that the processor is configured to determine an actual value of a measured characteristic of the signal that varies with the timing relationship between the MSKC and the CC of the user, and further configured to adjust the movement guidance based on the trend of the actual value so as to cause the actual value of the measured characteristic to approach a relative preferred value of the measured characteristic.

[0031] In some embodiments, the measured characteristic of the signal that varies with the timing relationship between the MSKC and the CC of the user includes at least one of a pulse amplitude, a peak to valley measure of signal waveform curvature, a measure of signal waveform peak curvature, a measure of signal waveform valley curvature, a measure of signal waveform complexity, and a measure of an asymmetry of the signal waveform. In some embodiments, the relative preferred value of the measured characteristic is a threshold crossing of an increasing trend, a threshold crossing of a decreasing trend, a local maximum, or a local minimum of the trend of the actual value of the measured characteristic. In some embodiments, the sensor technology includes photoplethysmography, impedance plethysmography, laser-Doppler blood flow, acoustic sensing, or arterial tonometry.

BRIEF DESCRIPTION OF THE DRAWINGS

[0032] For a better understanding of the present invention, and to show more clearly how it functions, reference will now be made, by way of example, to the accompanying drawings. The drawings show embodiments of the present invention in which:

[0033] FIG. 1 illustrates a system for determining a target MSKC to CC timing relationship and guiding a user to the target MSKC to CC timing relationship, in accordance with an embodiment.

[0034] FIG. 2 illustrates a system for receiving cardiac, musculoskeletal, or physiological cycle signals to determine a target MSKC to CC timing relationship and to guide the user to the target MSKC to CC timing relationship, in accordance with an alternative embodiment.

[0035] FIGS. 3A-B illustrate flow charts for sensing, calculating, and guiding a CC and MSKC timing relationship (s) of a user, in accordance with certain embodiments.

[0036] FIGS. 4A-C illustrate a timing relationship between central arterial pressure waveforms, peripheral arterial pressure waveforms, an electrocardiogram tracing, a targeted rhythmic musculoskeletal contraction cycle, and a timing of sensed MSKC events of a user, in accordance with some embodiments.

[0037] FIG. 5 illustrates a flow chart for guiding a user to a target MSKC to CC timing relationship using a CC sensor (e.g. an electrocardiogram) and an MSKC sensor (e.g. an accelerometer), in accordance with an embodiment.

[0038] FIGS. 6A-G illustrates a series of photoplethysmography, ECG, and accelerometer signals of a user, in accordance with some embodiments.

[0039] FIGS. 7A-B illustrate flow charts for synchronizing a timing of a rhythmic MSKC with a timing of a CC of a user using a measure of arterial blood pressure, volume, or flow (e.g. plethysmography), in accordance with some embodiments.

[0040] FIG. 8 is a block diagram of an exemplary system for controlling and adjusting automatically and in real-time the settings or behaviors of exercise equipment based on a user's sensed relative MSKC and CC timing.

[0041] FIG. 9 is a block diagram of the system of FIG. 8 showing additional components.

[0042] FIG. 10 illustrates a treadmill system for sensing a CC and MSKC timing of a user and guiding a user to the target MSKC to CC timing relationship, in accordance with an embodiment.

[0043] FIG. 11 shows an individual running on a treadmill with connections to an exemplary system.

[0044] FIG. 12 shows an individual running on a treadmill as in FIG. 11 with alternative components of the exemplary system.

[0045] FIG. 13 illustrates a biking system for sensing a CC and MSKC timing of a user and guiding a user to the target MSKC to CC timing relationship, in accordance with an alternative embodiment.

[0046] FIG. 14 shows an individual on an exercise bike with system components.

[0047] FIG. 15 is a flow chart showing exemplary closed loop control operation of the system.

[0048] FIG. 16 is a flow chart showing exemplary operation of the system.

[0049] FIG. 17 is a chart illustrating ECG and vertical axis accelerometer signals obtained on a user wearing a monitor while exercising.

[0050] FIG. 18 is a flow chart showing exemplary operation of the system.

[0051] FIG. 19 is a flow chart that illustrates an example control loop used by the system to adjust the incline of a treadmill to a value that causes a user's heart rate to settle near their sensed MSKC rate.

[0052] FIG. 20 illustrates a flow chart for calibrating a system for determining a target MSKC to CC timing relationship, in accordance with an embodiment.

[0053] FIG. 21 illustrates a wrist-based device for calibration of a CC sensor, in accordance with an embodiment.

[0054] FIG. 22 illustrates a head-based device for calibration of a CC sensor, in accordance with an alternative embodiment.

DETAILED DESCRIPTION

[0055] The following description of the invention is not intended to limit the invention to these embodiments, but rather to enable any person skilled in the art to make and use this invention. Disclosed herein are systems and methods for favorably coordinating musculoskeletal and cardiovascular or cerebrovascular hemodynamics.

[0056] In this disclosure, the terms cardiac cycle ("CC"), cardiovascular cycle, and cardiac pump cycle may be con-

sidered synonymous, referring to the activity of the heart during a single, complete, heart pump cycle (equivalently, a single heartbeat). The terms heart rate ("HR"), cardiac or cardiovascular cycle rate, and cardiac pump cycle rate may be considered synonymous. Numerous key aspects of the cardiac pumping cycle, as well as detectable signals that reflect those aspects, occur only once per heartbeat. These include, for example, elements of the heart's electrical activity, corresponding periods of cardiac muscle contraction (systole) and relaxation (diastole), the filling and emptying of the chambers of the heart, the individual heart valves opening and closing, and the associated arterial blood pressures and flows. Each of these aspects, elements, components, or events reoccurs with every heartbeat. Further, the phrases blood pressure, pressure, or arterial pressure may be used interchangeably, as when describing sensors, waveforms, or signals responsive to at least one of arterial blood pressure, volume, or flow, such as a plethysmographic sensor, for example.

[0057] In this disclosure, the terms musculoskeletal activity cycle and musculoskeletal activity pump cycle may be considered synonymous. As disclosed herein, MSKC equivalently may refer to the activity of the MSK during a single, complete, MSK pump cycle (e.g. a single stride or step running, pedal push biking [$\frac{1}{2}$ revolution of the pedal], stroke swimming, or pull rowing). Numerous key aspects of the MSKC, as well as detectable signals that reflect those aspects, occur only once per MSKC. One MSKC refers to the activity of the MSK system that results in peripheral vascular blood pumping during a single cycle of the rhythmic physical activity of the user. Musculoskeletal activity rate ("MSKR"), musculoskeletal activity pump cycle rate, musculoskeletal pump rate, and cadence may be considered synonymous, not to be confused with the fact that the term cadence can alternatively be commonly used to reference a multiple of the true MSKR (e.g. bicycle RPM ["cadence"] of 90 \rightarrow MSKR of 180, because there are two MSK pumping activities, one per leg, for each full revolution of the bicycle pedals). Examples of common MSKRs during physical activity include stride frequency in walking or running, leg pumping rate while pedaling on a bicycle, stroke rate when swimming or rowing, etc. Further, different MSKCs may occur simultaneously in a single user at different rates. For example, a swimmer may kick with their legs at a multiple of the rate that they pull with their arms and each of a rower's strokes includes both a pull and a push of the oars. In the following disclosure, the terms synchronize and coordinate, and derivatives of these terms, may be used synonymously to describe any type of consistently repeated pump timing relationship.

[0058] Described herein are systems and methods for coordinating CC and MSKC pumping activities to achieve MCP. MCP is considered optimized for a rhythmic physical activity when the CC and the MSKC are synchronized (i.e., coordinated) in a complimentary fashion such that the MSKC pumps maximal blood cumulatively into the central circulation (e.g. aorta) during early CC diastole, and the heart pumps blood maximally into the central circulation at the most overall favorable relative timing to the MSKC. As used herein, this optimal relative timing of the CC and MSKC pumps is generally considered the target MSKC to CC timing relationship. CC and MSKC pumping activities are coordinated to achieve MCP by guiding a user to a target MSKC to CC timing relationship, and MCP is achieved

when a user attains the target MSKC to CC timing relationship. In some embodiments, a user is guided to achieve MCP. Alternatively, in certain other embodiments, a user is guided to avoid inverse MCP (iMCP) in which the two pumping systems are coordinated unfavorably. The systems and methods described herein may take into account that, in some instances, a user may achieve MCP naturally during rhythmic MSK activity, at least for a period of time, without any external input.

[0059] Rhythmic MSK activity as described herein may refer to biking, running, rowing, walking, swimming, and/or any other type of rhythmic activity. Rhythmic may refer to any repeating pattern (e.g. 1, 2, 1, 2 . . . ; or 1, 2, 1, 2, 3, 1, 2, 1, 2, 3 . . .). For example, during running, the rhythmic stepping pattern may comprise: left foot, right foot, left foot, right foot, etc., where the steps occur with every heartbeat or with every other heartbeat. Alternatively, during rowing, rhythmic may comprise each stroke of the paddle in the water, where the stroke is timed based on the heartbeat, but not each heartbeat or necessarily using the same number of heartbeats between each stroke. Additionally, different parts of the MSK system of a user may simultaneously maintain different rhythms, e.g. during certain swimming strokes, a lower extremity kick rate may occur at a higher frequency than an upper extremity stroke rate.

[0060] In some embodiments, the system monitors a MSKC to CC timing relationship of the user and prompts, motivates, or otherwise guides the user to reach a target MSKC to CC timing relationship and thereby achieve MCP. A user of the system described herein may be any person performing rhythmic musculoskeletal activity. Peripheral or central physical locations adjacent to the circulation of a user, for example, locations on the arm, wrist or finger of an upper extremity, the ear lobe or canal, forehead, temple, retina, or elsewhere on the head may be monitored to determine a timing relationship from sensed hemodynamic effects (e.g. changes in arterial blood flow, volume, or pressure). As described herein, the timing relationship may be the timing relationship between the MSKC timing and the CC timing. In some embodiments, the timing relationship may be described as a phase relationship of the CC and MSKC pumping activities or the signals responsive to the respective pumping activities, or a time offset between them.

[0061] In further embodiments, a target HR may be chosen prior to or during an activity, based, for example, on comfort, preferred MSKR, desired effort, type of run (e.g. intervals, speed, etc.), coached target, calibration run, or a calculation based on calculated and tested or entered maximum HR.

[0062] In some embodiments, a MSKC to CC timing relationship of a user may be monitored and/or guided using an application on an electronic device, for example a mobile phone or a laptop. The application may run constantly in the background, for example, in a head mounted “smartglass” heads-up display/processor, an ear mounted “smart headphone” or earbud audio/processor, or in a wrist mounted “smartwatch” display/processor. The application may offer a prompt, such as an icon or audible signal that conveys that the HR is substantially an integer multiple of the MSKR, e.g. “HR≈step rate” during running or “HR≈2×step rate” during hiking up an incline. In some ambulation embodiments, the application may query the user whether or not the user would like to step to the beat. In accordance with preferred embodiments described herein, prompting a user to move to

the beat may only occur when the HR and the MSKR of the user are naturally substantially aligned, for example, when the user’s HR equals approximately an integer multiple of the frequency of his or her MSK activity.

[0063] In some embodiments, information about a user may be tracked, using appropriate sensors, before, during, and/or after one or more MSK activities. This information may be used during calibration of a target MSKC to CC timing relationship, for guiding the user to the target MSKC to CC timing relationship, and for tracking a user’s progress toward the target MSKC to CC timing relationship during use of the system. For example, subjective information may be tracked, such as a difficulty, satiety, energy level, or satisfaction “index.” The index may rely on feelings and/or emotions of the user regarding the exercise experience and how the body feels at periods before, during, and/or after the MSK activity. Other subjective information may be used, including pleasure and pain. Further, information including the amount of weight loss or gain that the user experiences may be tracked. For example, the system may enable a user to record his or her weight at a certain point before, during, and/or after the MSK activity. Weight data may be correlated with other measurements to provide useful information to the user.

[0064] In some embodiments, respiratory information is tracked. Such information includes, for example, respiratory exchange ratio, minute volume (V_E), volume of CO_2 produced, volume of O_2 consumed, O_2 debt, and/or force of expiration. By tracking the user’s respiratory information, and by presenting trends or changes in the respiratory information, the energy conservation advantage of the system is readily communicated to the user.

[0065] Other trackable information for calibrating, guiding, and measuring progress during use of embodiments of the system may relate to skin, muscle, interstitial fluid, and blood characteristics. For example, monitoring continuous or intermittent glucose or insulin levels may be useful, particularly for persons with diabetes. Alternatively or additionally, lactic acid or pH levels may also be tracked. In some embodiments, retinal, facial, muscular, and/or cerebral blood flow may be sensed and tracked. Retinal pulse embodiments may be captured, for example, by cameras. Pupil reactions may also be monitored. Acute, chronic, central, and peripheral blood pressure may also be tracked. Stroke volume and cardiac output may be tracked. Examples of capturing brain function and perfusion may extend beyond cerebral blood flow, to include EEG (electroencephalogram) sensed from a head mounted system or measures of cognitive function. HR variability may be measured to enable tracking of stress levels or other general health and fitness information. Further, information may be tracked that relates to the intensity, duration, ergonomics, and effectiveness of an activity, such as movement, acceleration, speed, magnitude of muscle contraction, and/or force per second. Sensed signals might include, for example, electromyography (EMG), accelerometry, pressure sensors, etc.

[0066] Other types of metrics may be measured, recorded, and/or used by the system during physical activity. In some embodiments, metrics may include efficiency metrics. Exemplary physical activity related efficiency metrics may include watts/beat (e.g. power per heart beat while pedaling a bicycle); watts/HR; $[\Delta\text{distance}\times\Delta\text{elevation}]/\text{beat}$; $\Delta\text{distance}/\Delta\text{elevation}/\text{HR}$; and $[\text{gradient}\times\text{distance}]/\text{HR}$. Slope, tilt or inclination can be expressed in a variety of

ways, including, but not limited to 1) a ratio of the rise to the run, for example $\frac{1}{20}$; 2) an angle, for example in degrees; and 3) a percentage called the “grade” ($\text{rise/run} \times 100$). Further exemplary metrics may include a “pulse-pace”, such as [heart beats]/mile; miles/beat; ft/beat, km/beat, watts/beat, strokes-mile, or rpm/mile may be monitored and tracked (wherein “beat”=heart beat).

[0067] Further, described herein are systems and methods directed generally to controlling automatically and in real-time the settings or behaviors of stationary and non-stationary exercise equipment (equivalently, apparatus) based on the user’s sensed relative MSKC and CC timing. This allows users to attain and maintain a targeted relative MSKC-CC timing relationship without requiring them to consciously respond to specific timing prompts.

[0068] The systems include sensors that are responsive to a user’s CC and MSKC, associated circuitry to provide respective signals to a microprocessor, exercise equipment that includes adjustable settings or behaviors, and interface circuitry between the microprocessor and componentry of the exercise equipment that causes changes to the settings or behaviors.

[0069] Any type of equipment or other mechanical device used in conjunction with a generally repetitive or rhythmic exercise can be used, including, for example, any form of treadmill, elliptical trainer, ski machine, bicycle (regular or stationary), rowing apparatus, stair-stepping machine, weight or resistance-based strength trainer or any other machine which a user uses in conjunction with a generally rhythmic physical exercise. Relevant adjustable settings of the equipment can include the speed, resistance, gearing, incline, stride length, or any other factor during the operation of the equipment that can affect a user’s MSKC and/or CC timing.

[0070] Operating algorithms used by the microprocessor are configured as closed-loop control systems that (1) use signals from sensors responsive to MSKC and CC activity to determine the value of the user’s relative MSKC vs. CC timing, (2) use this value in calculating a difference relative to a target timing relationship, and then (3) according to the difference, determine a value that is used by the interface to cause a change in one or more of the exercise equipment’s settings or behaviors that affects the user’s repetitive movements intrinsically. Accordingly, the timing of their movements is made to approach a targeted relationship with respect to their CC timing. In some embodiments, the user may not be consciously aware of the ongoing adjustments.

[0071] FIGS. 1 and 2 illustrate a system for determining a target MSKC to CC timing relationship and guiding a user to the target MSKC to CC timing relationship, in accordance with an embodiment. The system as shown in FIGS. 1 and 2 may be combined into one device or maintained as two or more separate devices in communication with one another. The system may be placed on or mounted to exercise or gaming equipment used or worn by a user. A wearable system may include a chest strap, helmet, headband, hat, visor, sports bra, shoe, watch, wristband, armband, ankle bracelet, headset, earpiece, earbuds, glasses/goggles, contact lens, embedded chip, patch, and/or any other type of adhesive, wearable, or mountable device. Equipment may include a bike, treadmill, elliptical trainer, stair stepper, rowing machine, boat, paddle, pacemaker, video gaming system, powered exoskeleton bionic devices, and/or any other type of equipment used during rhythmic physical

activity. Use and manipulation of exercise equipment to determine a target MSKC to CC timing relationship of a user and to guide a user towards the target MSKC to CC timing relationship will be discussed in further detail below in connection with FIGS. 10-14.

[0072] As shown in FIGS. 1 and 2, a system for determining a target MSKC to CC timing relationship includes one or more sensors, detectors, or sensing elements 10a, 10b (collectively 10) for delivering or transmitting information to one or more processors/controllers 11. The processor 11, as shown in FIGS. 1 and 2, processes, converts, or otherwise transforms the sensor information using hardware and software and transmits or delivers the resulting relevant guidance and/or adjustment information to at least one of a user input interface 12, user guidance interface 13, or an equipment interface 14. Optionally, the system may include a front end 15, as shown in FIG. 2. The front end 15 pre-processes, transforms, separates, or otherwise deciphers information received from the one or more sensors 10 and transmits the information to the processor 11. In some embodiments, transmitting, delivering, or otherwise transferring information between system components may be accomplished wirelessly (e.g. through cellular, Wi-Fi, Bluetooth, ultrasound, or ANT+ technologies), and/or through a hardwired connection. For example, the hardwired connection may include an electrical connection, universal serial bus (USB), or FireWire, for example Apple’s IEEE 1394 High Speed Serial Bus.

[0073] In some embodiments, as shown in FIGS. 1 and 2, a sensor, detector, or sensing element 10 is used to detect a physiological parameter, feature, or metric and transmit the information about the physical parameter in the form of a raw or pre-processed signal. A sensor technology 10 may, for example, include electrocardiography (ECG), accelerometry, electromyography (EMG), electroencephalography (EEG), plethysmography (e.g., photoplethysmography (PPG) or impedance plethysmography (IPG)), arterial tonometry, or use of a pressure sensor, a switch, a camera, a gyroscope, a proximity sensor, a glucose sensor, a pH sensor, a lactic acid sensor, laser-Doppler blood flow, and/or an acoustic sensor (e.g. ultrasound, SONAR). In some embodiments, a physical parameter detected by the sensor 10 may include repetitive features of a CC or MSKC, as shown in FIGS. 4 and 6. In some embodiments, the features useful for identifying the CC pump timing may correspond to an ECG R-wave, an ECG T-wave, an end of the ECG T-wave, a peak of a cardiovascular systolic pressure, a nadir of a diastolic cardiovascular pressure, and/or a transition point in a cardiovascular pressure of the user, as shown in FIGS. 4A-C. These features and their respective timings may be identified from the raw signals by processing algorithms programmed into processor 11, or alternatively the feature identification process may be incorporated into the sensing device directly. Similarly, features useful for identifying the MSKC pump timing may be determined using algorithms programmed into the processor 11 from raw signals sensed by one or more sensors 10 (e.g. 10b), or alternatively incorporated into the sensing device directly.

[0074] As described herein, a signal may include two or more characteristics. In some embodiments, a first characteristic of a signal may include a repetitive feature of a CC, for example a T-wave or an R-wave of the electrical signal of the CC or a peak pressure of a plethysmography signal, and a second characteristic of the signal may include a

repetitive feature of a musculoskeletal activity, for example a step timing of a user. In some embodiments, two or more characteristics may be derived using processor 11 from one signal. For example, at least one of HR and MSKR and MSKR to CC relative timing information may be derived from characteristics of a signal from the same plethysmogram or a plethysmographic sensor 10.

[0075] In some embodiments, as shown in FIGS. 1 and 2, a user input interface 12 may receive information from the processor 11. The user input interface 12 may be configured to receive commands or cues from a user that are delivered to the processor/controller 11, as well as configured to deliver commands or cues from the processor/controller to a user or device/component. Commands may be tactile, audio, visual, or in any other form. In some embodiments, tactile commands from the user may include keypad strokes, actuation of switches or buttons, and/or touch interactions delivered by the user. Additionally, vibrations, taps, electrical signals, or nudges are examples of commands that may be provided to the user from the system. Audio commands may include those received by the user input interface 12 from the user, the processor 11, the sensors 10, or the user guidance interface 13. Further, audio commands delivered to the user may include commands that direct the MSK activity of the user, including, for example, a metronome, the beat of music, drum beats, changes in tonal qualities of an audible prompt, and/or games and words. In some embodiments, visual commands or cues may include visual displays or prompts, analogue dials, graphs, movies, games, or any other type of viewable command. In certain embodiments, tactile guidance may include at least one of guidance on a timing, location, magnitude, and/or direction of MSK activity, using one or more separate means or skin locations for stimulating the user. For example, a mechanical or electrical tactile prompt may be provided to one or more locations on the user's hand, wrist, head, or foot, depending on the placement of the prompt device. In further embodiments, the magnitude, quality, or location of the prompt may be varied as to guide the user's MSK activity, for example, to guide at least one of a user's speed, effort, or direction while walking or running.

[0076] As shown in FIG. 1, a system may include a user guidance interface 13. In some embodiments, the user guidance interface 13 may be combined or merged with the user input interface 12, such that the user input interface 12 is the user guidance interface 13. Alternatively, the user guidance interface 13 may be combined or merged with an equipment interface 14, as shown in FIG. 2, such that the equipment interface 14 is the user guidance interface 13. As described herein, guidance includes enabling a user to obtain and maintain a target MSKC to CC timing relationship.

[0077] In some embodiments, the user guidance interface 13 may include a prompt device that provides a recurrent prompt (guidance) at a prompt rate to the user as a timing indication for performance of the rhythmic musculoskeletal activity. The prompt device may be controlled by the processor 11. In some embodiments, the prompt rate may be substantially equal to a HR or a cadence of a user. In other embodiments, a HR of the user may be substantially an integer multiple of the prompt rate. In some embodiments, predetermined target cadences or prompt rates may be available to a user. For example, the target cadences (i.e. to achieve the target MSKC to CC timing relationship) may be based on a user's natural or preferred cadences, type of

activity (e.g. walking vs. jogging vs. running a competitive 5K), duration of activity, gender, age, fitness level, other demographic information, user anatomy (e.g. height, weight), or other diagnostic information.

[0078] Timing of guidance signals may initiate automatically, by user request through a user input interface 12 when HR and MSKC timing are nearly aligned, or the user may be signaled or reminded when the guidance is available or appropriate through user input interface 12. The guidance may be recurrent. In some embodiments, the guidance may fade away or become imperceptible as long as the user achieves and maintains the target MSKC to CC timing relationship. The guidance may resurface or become perceptible if the user fails to sustain the target MSKC to CC timing relationship during a given time period. In some embodiments, the system senses that a user responds late or early to guidance and adjusts the guidance automatically to guide the user to the target MSKC to CC timing relationship. Alternatively, in some embodiments, a user may adjust the guidance manually, for example to increase or decrease a target MSKR or HR, such that the target MSKC to CC timing relationship dictated by the system is reset accordingly.

[0079] In some embodiments, the user guidance interface 13 of the system may include music to guide the MSKC timing of the user. Accordingly, a user may be prompted with music having a beat that will guide the user to a target MSKC to CC timing relationship. Music may be selected in real-time, pre-selected, or automatically selected, for example, in response to the measured or known beat frequency of the songs and the actual or target MSKR of the user. Playlists or sequences of musical renditions may be defined by the user, or suggested by the system to the user. Playlists may vary depending on the HR, MSK activity, and other states desired for a given physical activity. Musical selections used to prompt MSK activity timing may change in beat frequency, beat volume relative to overall music volume (e.g. drum beat, base guitar, concurrent metronome), overall music volume, or other features to guide the user. In an exemplary embodiment wherein a drum beat of a musical track is the timing prompt for a user, the volume of the drum beat prompt relative to the volume of the musical track may gradually increase above a baseline or added on top of the track, as the accuracy or consistency of the user's timing relative to the prompt decreases. Alternatively, the volume of the drum beat prompt relative to the remainder of the musical track may decrease or return to a baseline in response to a sustained improvement in the user's MSKC timing accuracy or consistency. In certain embodiments, the system may further be configured to constantly adjust the playback speed of the music to fine-tune the beat rate used to guide the user. Additionally, the music with altered playback speed can be pitch-corrected to maintain the proper intonation.

[0080] In some embodiments, the system may deliver a new prompt or modify an existing prompt in order to indicate to the user the need to more accurately or consistently step to the underlying beat of the delivered music and/or the need to make corrections in MSK activity such as changes to stride length, degree of knee bend, heel strike, toe-off, exercise resistance, bicycle gear, or arm swing. In some embodiments, a user may hear a change in prominence of the underlying beat of a song (for example the base drum, base guitar, and/or an added metronome beat) relative to the

rest of the song as an indication to the user that he or she needs to more accurately move with the timing of the underlying beat of the music, improve identification of the prompt within the music, or pay better attention to moving to the beat. Musical communication may be pre-defined by the user so as to suit his or her understanding or preferences. A tactile prompt can be provided at a prompt rate in addition to or instead of an audible prompt.

[0081] In some embodiments, guidance may be provided by game embodiments that utilize metrics. For example, one embodiment of the system includes sensors that continuously run in the background during any rhythmic physical activity. In this embodiment, information from sensors and/or MSK activity guidance may be offered, made available, or automatically turned on as a biofeedback prompt when, during the course of that activity, the HR naturally approaches or approximates an integer multiple of the MSKR of the user (e.g. 1x, 2x, 3x. . .). For example, biofeedback may be provided audibly via an earbud or other earpiece; visually via head-mounted smart eyeglasses or contact lenses or a smart-watch; via tactile feedback from a smart-watch, smart-headset, or smart-shoe; or via any other type of biofeedback enabled device, as described herein.

[0082] Games and gaming systems may be leveraged, including, for example, an Xbox Kinect type audio-visual gaming hardware that includes cameras that can visualize at least one of the MSKC and the CC of the user, as well as provide at least one of audio, visual, and tactile MSKC timing guidance to the user. In embodiments of the system and method, MSKC timing inputs may be received and/or captured by a camera(s), such that the camera(s) may capture other MSK activities beyond foot strike timing and/or arm motion timing. Further, CC timing inputs may be acquired by gaming sensors. For example, a camera may be used to monitor CC timing via at least one of subtle rhythmic skin color changes, small temperature (IR) changes, and tiny rhythmic movements (e.g. head bobbing) caused by arterial blood flow and pulsatile pressure changes during the CC. Gaming system embodiments may include wearable sensors for ambulatory versions, whereas a video camera(s) may enable sensing of MSKC timing without wearable sensors. Alternatively, an accelerometer, other position/orientation sensors, floor based pressure sensors, or EMG may be used to measure the whole body or specific limbs or muscles, such as number of muscles, force of contractions, magnitude and/or speed and/or acceleration of movement that achieves the target MSKC to CC timing relationship. A game may be configured to give points or other scalable credit for increases in well-timed physical activity metrics relative to timing targets, including foot strike, limb movement metrics, and other body movement metrics. Limb movement metrics may include speed, acceleration, change in center of mass, or body movement. Body movement metrics may include speed, acceleration, center of mass, side-to-side movement, or change in height.

[0083] Algorithms used by the system for determining a user's actual CC timing may include calibration or corrections for arterial pulse transit time related to at least one of the user's height, age, HR, pulse amplitude, or a CC measurement location, for example. Acquisition of CC timing may include analysis and/or amplification of plethysmographic signals, skin color changes, and/or head movements (e.g. following set points on face of the user) related to the pulsatile flow of arterial blood. Alternatively or additionally,

acquisition of CC timing may include information from other sensors and wearable devices, for example, an ECG. As illustrated in FIGS. 21 and 22, an ECG signal may be obtained simultaneously with an arterial pulse signal, enabling calibration of the pulse transit delays in monitoring the CC timing, because the heart's electrical activity (ECG) reliably reflects the true timing of the CC due to the speed with which electrical signals travel through the body, while pulse pressure signals travel much more slowly at variable speeds that are effected by user size, age, arterial anatomy, sensor placement, and cardiovascular physiology (e.g. cardiac contraction force, blood pressure, hydration, blood viscosity, temperature, vasoconstriction, arterial wall stiffness, etc.)

[0084] FIGS. 3A-B illustrate flow diagrams of a system in accordance with preferred embodiments that include sensing a CC and MSKC timing of a user. As shown in FIGS. 3A-B, the system senses CC timing 16 and MSKC timing 17 of a user. Any number of sensing technologies may be used, for example ECG or plethysmography can be used to sense CC timing. Optionally, as shown in FIG. 3A, additional (e.g. 2nd, 3rd, 4th, Nth) MSKC timings 18 of a user may be sensed by the system, each being compared in step 21 to the CC timing of the user and/or to each other.

[0085] FIG. 3A illustrates a flow diagram for sensing a CC and MSKC timing of a user, for example using ECG and an accelerometer. As shown in FIG. 3A, a processor is used to identify a valid CC 19 and a valid MSKC 20 event timing. A valid CC event 19 may be any point or portion of a CC or other information that conveys CC timing information, as discussed above. A valid MSKC event 20 may be any point or portion of a rhythmic physical activity that conveys MSKC timing information, as discussed above. Valid events 19 and 20 may correspond to those that pass signal processing metrics designed to reject false events caused by noise or other interferences that are unrelated to the user's heart-beat or relevant MSK activity. For example, detected events in the CC signal that occur too soon after a previous valid CC event and that would otherwise represent a non-physiologic HR or one that is far greater than the user's recent valid HR may be rejected.

[0086] In some embodiments, an actual (e.g. real-time) relative MSKC to CC timing is determined and compared to a target relative MSKC to CC timing 21. The difference between the actual relative MSKC to CC timing and the target MSKC to CC timing 21 is calculated, representing a difference value in a feedback loop, which is used to determine a correction, if needed, in any guidance a user requires to achieve the target MSKC to CC timing relationship. In some embodiments, the timing relationship between the first MSKC timing and the second MSKC timing may be obtained using a first processor. Further, in some embodiments, the timing relationship between the second sensed MSKC timing and the CC timing may be obtained by the same first processor or on a second processor. Each MSKC to CC and MSKC to MSKC timing relationship is characterized by the elapsed time between the occurrence of one component of the first signal and the occurrence of one component of the second signal. In some embodiments, this timing relationship may further be normalized (i.e., divided) by the elapsed time between two subsequent occurrences of the one component in the first or second signal. Additionally,

in some embodiments, the timing relationships may be recalculated on a continuous real-time basis, at random times, or at various intervals.

[0087] In some embodiments, correction values **9** may be computed to adjust the timing of the guidance as a function of the correction values. The correction values may be based on the CC timing of the user, the first or second MSKC timings of the user, a relative MSKC to CC timing, the difference to a target MSKC to CC timing relationship, or one or more time delays, offsets, or other information. Further, a user may be guided or prompted to achieve the target MSKC to CC timing relationship based on the adjusted timing of the guidance **23**. In some embodiments, the flow diagrams of FIGS. **3A** and **3B** may repeat in a loop function. Alternatively, the user may achieve and maintain the target MSKC to CC timing relationship, and thus not require any adjustment in the guidance. In some embodiments, the loop function may be used to calibrate a system to one or more physiological preferences of a user, as will be described below. For example, the system may adjust the guidance to a user that steps early or late relative to a target MSKC to CC timing relationship upon receiving the guidance. Alternatively, a user may naturally achieve MCP occasionally during certain rhythmic musculoskeletal activities. Thus, the system may be calibrated to adjust the guidance to enable the user to maintain the natural MCP of the user.

[0088] FIG. **3B** illustrates a flow diagram for sensing a CC and MSKC timing of a user, for example with PPG or IPG, in accordance with an embodiment. As shown in FIG. **3B**, the system may sense a signal from a sensor **16** that correlates to the CC of a user to calculate a HR **6**, and another signal of the user using a sensor **17** that correlates with the MSKC **17** in order to calculate an MSKC rate (MSKR), using any number of sensing technologies. In some embodiments, signals that correlate to both the CC and MSKC of a user may be obtained from a single sensor, **16** or **17**. For example, as will be described more fully below, a plethysmographic sensor can be used to sense one or more of CC timing, MSKC timing, and information regarding MSKC to CC timing relationships. In some embodiments, the timing relationships may be recalculated on a continuous real-time basis, at random times, or at various intervals.

[0089] Hemodynamic counterpulsation requires coordination of the timing of a musculoskeletal activity blood pump cycle (e.g. a gait cycle) to the timing of a cardiac cycle during rhythmic physical activity. One or more sensors configured to measure the timing of the cardiac cycle and the timing of the musculoskeletal activity blood pump cycle can be useful tools for identifying at least one of the absolute timing of the two pump cycles and the relative timing of the two pump cycles. Exemplary sensors for measuring an absolute timing of the cardiac cycle and the musculoskeletal cycle include ECG and accelerometer-based sensors, respectively. Exemplary sensors for measuring the relative timing of the two pump cycles include those that are responsive to cyclically-varying arterial blood volume or velocity in a tissue of a user, for example PPG (photoplethysmographic) sensors, applanation tonometry sensors, infrared doppler sensors, etc. Sensors configured to measure an absolute timing of the cardiac cycle, such as ECG sensors, often require the use of specialized constricting clothing, chest straps, or disposable adhesive patches to ensure that the ECG electrodes are stable against the skin of the user,

making their use during certain applications, like exercise or walking, uncomfortable, inconvenient, and/or costly. In contrast, sensors that are configured to measure a relative timing, such as PPG sensors, are increasingly integrated into many commonly used wearable devices (along with accelerometers, in many cases) making these relative timing sensors potentially more comfortable, cost-effective, and convenient than an ECG sensor.

[0090] Further, sensors that can be used to measure a relative timing of the cardiac cycle, for example PPG sensors, can be very unreliable or inaccurate indicators of absolute cardiac cycle timing due to the inherent variability in pulse transit time between the heart pump and the site of the sensor where the blood volume or velocity is being measured, due to the fact that several factors impact pulse transit time between individuals, and within an individual at different times. For example, changes in arterial compliance, arterial distance from the heart to the site of the sensor, blood viscosity (as can occur with changes in hydration or hematocrit), arterial vascular tone, and ventricular contractility can all change pulse transit time in a given individual over time or between different individuals. Variability in movement and inertia during the musculoskeletal pump cycle can also affect the consistency of pulse transit time.

[0091] For these reasons, it can be difficult to use a sensor responsive to cyclically-varying arterial blood volume or blood velocity in a tissue of a user (e.g. PPG) to accurately measure absolute cardiac cycle timing. However, such a sensor can be very effectively used in embodiments of the invention to determine the relative timing relationship between the cardiac cycle and the musculoskeletal blood pump cycle. This is because the morphology of the arterial pulse pressure, volume, or flow velocity waveforms predictably varies with the timing relationship between the two pump systems (cardiac and musculoskeletal). This predictable behavior can be particularly useful when the frequencies of the two pump cycles are either equal or an integer multiple of one another. Morphological attributes of the waveforms vary in a manner that is consistent between and within users at certain preferred anatomic locations, such as when the sensor is located on the user's chest or is positioned on a user's head or other location above the user's heart.

[0092] For example, FIG. **6A**, as described elsewhere herein, illustrates the dramatic and consistent changes in PPG waveform amplitude that can be caused by a user stepping at a rate that is slightly different from their heart rate. FIGS. **6B** and **6C** illustrate sustained forehead PPG amplitude characteristics resulting from stepping at a systolic timing and diastolic timing, respectively. A closer look at the easily identifiable relative waveform amplitudes and morphologies of forehead PPG data resulting from diastolic step timing is illustrated in FIG. **6D** to the systolic step timing illustrated in FIG. **6E**.

[0093] Therefore, certain embodiments of a method for achieving a favorable relative timing relationship between a rhythmic musculoskeletal activity cycle (MSKC) of a user and a cardiac cycle (CC) of the user includes: recurrently providing an output including a movement guidance prompt from a prompt device to the user for guiding performance of a rhythmic musculoskeletal activity; and repetitively: detecting a signal, using a sensor that correlates to a cyclically-varying arterial blood volume or velocity in a tissue of the user; determining, with a processor, a measured character-

istic of the signal, which varies with adjustments to the timing relationship between the MSKC and the CC of the user, wherein the measured characteristic comprises at least one of: a measure of peak amplitude, a measure of average amplitude, a measure of peak to valley height, a measure of waveform complexity, and a modulation amplitude, as described in connection with FIGS. 6A-6G; measuring, with the processor, an instantaneous behavior of the measured characteristic; comparing, with the processor, the instantaneous behavior to a recent historical behavior of the measured characteristic over a given rolling window of time during performance of the rhythmic musculoskeletal activity; and when the measured characteristic displays a trend relative to a local instantaneous or average maximum of the measured characteristic, automatically adjusting, with the processor, the movement guidance to move the user towards the local instantaneous or average maximum of the measured characteristic in order to achieve a hemodynamically more favorable timing relationship between the MSKC and the CC of the user.

[0094] As the user is prompted to adjust his/her rhythmic physical activity relative to a cardiac cycle timing to achieve MCP during performance of the rhythmic physical activity, the measured characteristic, for example a measure of peak amplitude, a measure of average amplitude, a measure of peak to valley height, a measure of waveform complexity, or a modulation amplitude, can vary favorably or unfavorably with the adjustments to the timing relationship between the MSKC and the CC of the user.

[0095] As shown in FIG. 3B, in some embodiments, if the HR of the user approaches an integer multiple of the MSKR ($(n \times \text{MSKR}) - \text{HR}$, where $n = \text{any integer } 1-10$) of the user (with an absolute difference $< x$ per minute)⁵, then a characteristic (or set of characteristics) of the sensor signal can be used to guide the user towards a target MSKC to CC timing relationship. For example, the sensor signal may be a PPG and the characteristic may be pulse amplitude in the PPG or, in another embodiment, a combined measure of pulse amplitude and pulse complexity. The change in the value of the characteristic that represents the MSKC to CC timing relationship may be calculated to determine an amount and nature of guidance a user requires to achieve the target MSKC to CC timing relationship 8, as will be described in further detail in association with FIGS. 6-7. In some embodiments, correction values 9 may be computed to adjust the timing of the guidance as a function of the correction values. A user may be guided or prompted to achieve the target MSKC to CC timing relationship based on the adjusted timing of the guidance 23. In other embodiments, as described later in FIGS. 7, the MSKC timing may be held constant and the user may be guided to the target MSKC to CC timing relationship by guiding changes in CC timing by guiding changes in the effort invested in the MSK activity, e.g. changes in MSKC speed, acceleration, power, resistance, stride length, or incline during exercise. In some embodiments, the flow diagram of FIG. 3B may repeat in a loop function 4, as described above. Alternatively, the user may achieve and maintain the target MSKC to CC timing relationship, and thus not require any adjustment in guidance. In some embodiments, the loop function may be used to calibrate a system to one or more physiological preferences of a user, as will be described below.

[0096] In accordance with the description above, FIGS. 4A-C illustrate a timing relationship between central arterial

pressure waveforms, peripheral arterial pressure waveforms, an electrocardiogram tracing, a targeted musculoskeletal contraction cycle, and a timing of sensed MSKC events of a user, in accordance with preferred embodiments. FIGS. 4A-C are shown aligned horizontally in time to each other for the purpose of illustration, such that the information has been sensed, detected, or collected by one or more sensors or sensor technologies as described above and processed by a processor. The sensed timing relationships, as shown in FIGS. 4B and 4C, may be used to determine the MSKC to CC timing relationship of a user. In general, central arterial waveform 32 represents exemplary arterial pressure in the aorta of an individual at rest, while waveform 34 represents at least one of an exemplary simultaneous peripheral arterial pressure, flow, and/or volume (e.g. peripheral PPG or blood pressure signal) of the same individual. As shown in FIG. 4A, simultaneously monitored exemplary central arterial pressure waves 32 and peripheral arterial pressure waves 34 are temporally offset from one another due to arterial pulse transit time, the time required for the arterial pressure waves to propagate through the arterial circulation from the heart and central circulation to a given peripheral location in the body of the user. Each of these waveforms exhibit changes in arterial pressure caused by the systolic 25 and diastolic 29 portions of the CC, which may include a peak systolic pressure 31, that repeats at the HR of the user.

[0097] Further, as shown in a simultaneous electrocardiogram (ECG) tracing in FIG. 4B, the representative ECG signal 22 (illustrative of the tracing one might obtain, for example, from a chest strap lead), includes various different waves including P-waves, Q-waves, R-waves, S-waves, and T-waves. R-waves 24 (24a, 24b, and 24c) represent depolarization of the ventricular muscle of the heart. R-waves 24 repeat with each heartbeat at a HR of a user and are readily identifiable in an ECG signal 22. Therefore, in some embodiments, R-waves 24 may be utilized in the measurement of the HR via the measurement of the duration of R-to-R intervals (RRI) 26. The T-wave 28 reflects ventricular repolarization. End T-wave 30 may be used as a marker of the approximate timing of aortic valve closure, which marks the beginning of diastole during the pumping cycle of the heart. The timing and characteristics of these waves in FIGS. 4A-B, like other similarly sensed waves and wave markers, are representative of the timing of the CC and therefore may be used in calibrating, guiding, and/or tracking a user and to coordinate MSKC and CC hemodynamics to achieve a target MSKC to CC timing relationship.

[0098] As shown in FIG. 4C, skeletal muscle contraction cycles 36 include periods of relaxation and contraction, as indicated by the dotted lines in FIG. 4C and, with respect to the timing of a user's CC shown in FIGS. 4A and 4B above, may include a target MSKC to CC timing relationship, in accordance with embodiments of the methods and systems. While exemplary skeletal muscle contraction/relaxation cycles 36 and prompts 35 are illustrated in FIG. 4C, arterial and venous MSK induced blood pumping also may be caused by changes in inertia during many types of rhythmic physical activity. Also, while exemplary central 39 and peripheral 40 arterial waveforms are illustrated in FIG. 4C, other important factors in optimizing MSKC blood pumping and target MSKC to CC timing relationships during many types of physical activity may take place but are not illustrated by the arterial waveform, for example venous blood pumping from MSKC induced skeletal muscle pumping.

[0099] As is illustrated in FIG. 4C, both the CC and MSKC pressure waves can be sensed simultaneously by a sensor responsive to changes in the arterial blood pressure, volume, or flow. Further, as is illustrated in FIG. 4C, when HR and MSKR are equal, then the MSKC may create pressure waves within the arterial circulation that are substantially at the same frequency as the pressure waves created by the CC. Exemplary arterial pressure waveform 39 represents an approximation of the central arterial pressure during MCP, wherein maximal MSK induced blood pumping is seen in the central arterial circulation during early diastole. This same waveform 39, however, may also represent an approximation of the peripheral arterial pressure, for example at the head of a user, during MSK-induced iMCP due to inertial effects and/or the impact of pulse transit time on arterial waveform shape and timing. Waveform 39, when observed centrally during MCP, may be very similar in appearance to the central waveform that can be produced during other types of medically induced therapeutic counterpulsation techniques, including intra-aortic balloon counterpulsation (IABP) and external counterpulsation (ECP). Waveform 39 may also illustrate the shape of a target peripheral arterial waveform during ECP and IABP counterpulsation, because, with the user at rest, the pressure flow waves created by the two favorably coordinated pumps (e.g. CC & ECP pumps) can maintain their relationship to one another as the waves propagate through the circulation of the user. Further, an exemplary peripheral arterial pressure waveform 40, as might be sensed from a location on the head of a user during MCP is illustrated, which also represents an approximation of an exemplary central arterial waveform during iMCP.

[0100] Because physical activity can cause blood pumping via both MSK contraction/relaxation cycles and through changes in inertia, the location of an arterial sensor can be important in determining the waveform timing characteristics of the waves created by each of these separate pumping mechanisms. For example, (1) pulse transit time from a CC is increased with the arterial distance of the sensor from the heart; (2) pulse transit time from a skeletal muscle contraction pumping location is also increased with the arterial distance from the skeletal muscle doing the pumping; while (3) the inertial pump waveforms occur concurrently with the changes in inertia that create them, but their amplitude and direction can be dramatically effected in their relationship to skeletal muscle pump and the CC pump waveforms by the location of the sensor, for example, at, above, or below the heart and/or skeletal muscle pump (e.g. sensor at head vs. chest vs. foot of the user during running) or in other examples, on a limb held substantially parallel to the ground vs. one held substantially perpendicular to the ground in one direction vs. one held substantially perpendicular to the ground in the opposite direction (e.g. wrist based sensor with hands held above the head vs. hands kept at lower chest vs. hands kept below the waist during running). Because wave amplitude and timing in response to a CC and MSKC can change with different activities and physiologies and sensor locations, calibration of the system to user, physiological variables, sensor location, and specific physical activity can be important.

[0101] As shown in FIG. 4C, examples of target MSKC to CC timing relationships are illustrated, comprising periods of skeletal muscle contraction during central diastole 29, as shown in FIG. 4A, followed by periods of relaxation during

central systole 25. In exemplary target MSKC to CC timing relationship 36, the user has been guided to perform the portion of the rhythmic MSK activity that results in maximal MSKC blood pumping to begin at timing prompts 35 (black triangles) that repeat with each instance of the CC such that the ratio of MSKC:CC occurrences is 1:1. Alternatively, the MSKC prompts may be timed at the same location in the CC, but less frequently (e.g. with every other CC (1:2), every third CC (1:3), or every fourth CC (1:4)), wherein the HR is an integer multiple of the MSKR. As shown in FIG. 4B, % R-R interval scale 38 provides a graphical representation of the percent of the R-to-R interval (RRI) 26 nomenclature, one RRI representing one full CC. % RRI may be computed as the amount of time between an MSKC event and the most recent prior CC event, divided by the amount of time between successive CC events, multiplied by 100. For example, 0% and 100% of the RRI represent the timing of the R-waves (e.g. 24a, 24b, 24c, etc.) in the CC, while 25% of the RRI is a quarter of the way between successive R-waves, and 50% is the mid-point between two sequential R-waves 24 of a CC. Scale 38 of the RRI may alternatively be expressed fractionally as a value from zero to one, in units of degrees between zero and 360 degrees, or in radians between zero and 2π radians (e.g., 25% = $0.25 \times 90 \text{ degrees} = 1.57 \text{ radians}$), equivalent to the percentage terminology. Values greater than 100% describe events in a subsequent RRI (e.g., 130% represents a 30% location in the following interval). Thus, the RRI may be used to align prompts and musculoskeletal contractions within the same location of each CC over time.

[0102] In some embodiments, multiple MSK activities, involving different muscle groups across the user's body, may be performed simultaneously or sequentially by a user, with each of these activities having its own MSKC timing and either a shared or unique target MSKC to CC timing relationship. In such a scenario, the relative timing of each MSKC to CC may confer separate cumulative hemodynamic effects on the central and peripheral circulation of a user, thereby impacting the magnitude of overall MCP or iMCP. MCP is considered optimized for a rhythmic physical activity when the CC and the MSKC are favorably coordinated so as to generate early diastolic pressure waves in the central circulation similar to those of waveform 39 in FIG. 4C. In some embodiments, it may be preferred to vary the target MSKC to CC timing relationship to optimize hemodynamics for different simultaneous or sequential MSK activities. Further, guiding a user to accomplish MCP or other MSKC to CC timing relationships may be desired, for example, in order to alter blood flow to specific MSK or non-MSK tissues, for example to improve cerebral perfusion.

[0103] FIG. 5 illustrates a flow chart for guiding a user to a target MSKC to CC timing relationship. A method for guiding a user to a target MSKC to CC timing relationship of a preferred embodiment includes detecting a first signal responsive to a CC timing of a user using a first sensor S500; determining a HR of the user using a at least a portion of the first signal detected by the sensor S510; providing a recurrent prompt from a prompt device to the user as a timing indication for performance of a rhythmic MSK activity S520; detecting a second signal responsive to a rhythmic MSK timing of the user that repeats at a musculoskeletal activity cycle rate (MSKR) of the user using a second sensor S530; determining an actual MSKC to CC timing relationship between MSKC and CC signals S540; comparing the

actual timing relationship of the CC and MSKC signals to a target timing relationship of the CC and MSKC signals S550; and adjusting the timing indication of the recurrent prompt from the prompt device to the user based on the difference between the actual timing relationship and the target timing relationship so as to reduce the magnitude of the difference S560. The method repeats by looping back from step S560 to S500, with the net effect of recurrently prompting and guiding the user so as to reduce the magnitude of the difference. In some embodiments, the method preferably uses an accelerometer and an ECG to determine actual and, in some embodiments, target MSKC to CC timing relationships of a user, although any CC and MSKC sensor or sensor combination may be used as described above in connection with FIGS. 1 and 2.

[0104] As shown in FIG. 5, step S500 includes detecting a first signal responsive to a CC timing of a user using a first sensor. Further, step S510 includes determining a HR of the user using at least a portion of the first signal detected by the first sensor. In some embodiments, a CC signal, or a portion of the cardiac signal, may include any recurrent aspect or feature of a CC, as described above, for example an R-wave of an ECG, a systolic peak of a plethysmogram, or a Fourier transform of either of these exemplary signals.

[0105] As shown in FIG. 5, step S520 includes providing a recurrent prompt from a prompt device to the user as a timing indication for performance of a rhythmic MSK activity. In some embodiments, the recurrent prompt repeats at a prompt rate such that the HR is substantially an integer multiple of the prompt rate.

[0106] As shown in FIG. 5, step S530 includes detecting a signal responsive to a rhythmic MSK timing of the user that repeats at an MSKR of the user using a second sensor. Step S530 functions to determine a MSKC timing of a user, such that an actual MSKC to CC timing relationship may be calculated as shown in step S540. In some embodiments, one or more sensors, for example an accelerometer, EMG, or any position/orientation sensor, may be used to sense aspects of an MSKC of a user, such that an actual MSKC to CC timing relationship may be calculated. For example, maximal MSK muscle contraction may be synchronized with the beginning of diastole in the CC of the user, as shown in FIGS. 4A-C. In some embodiments, step S530 may further include determining the MSKR of the user using the data from the second sensor with a processor. In some embodiments, the sensor used to sense the CC of a user (S500) may be the same sensor used to sense the MSKC (S530) of the user. Alternatively, two or more different sensors may be used to determine a CC and MSKC of the user.

[0107] As shown in FIG. 5, step S540 includes determining the actual MSKC to CC timing relationship between first and second signals. The actual timing relationship may be the measured timing relationship between the MSKC timing and the CC timing. For example, the actual MSKC to CC timing relationship of a user may correspond to MCP, to iMCP, or somewhere in between. Generally, most users not prompted to do otherwise will unintentionally vary in their MSKC to CC timing relationships during a rhythmic MSK activity.

[0108] As shown in FIG. 5, step S550 includes comparing an actual timing relationship of the CC and MSKC signals determined in step S540 to a target timing relationship of the CC and MSKC. Step S550 preferably utilizes a target MSKC to CC timing relationship that enables a user to

achieve MCP. In some embodiments, the target MSKC to CC timing relationship of a user may correspond to a condition when the CC and the MSKC blood pumps work in a complementary fashion. In certain other embodiments, a target MSKC to CC timing relationship for a user may correspond to, for example, simply avoiding persistent alignment of maximal MSKC blood pumping of the user with a peak of a systolic arterial pressure signal of the user so as to prevent the two pumping systems from persistently working against each other.

[0109] As shown in FIG. 5, step S560 includes adjusting a timing indication of a recurrent prompt from the prompt device to the user based on a difference between the actual timing relationship and the target timing relationship so as to reduce the magnitude of the difference. Step S560 preferably functions to guide the user towards the target MSKC to CC timing relationship. As shown in FIG. 5, step S560 loops back to step S500 so as to repetitively update the recurrent prompt and guide the user towards substantially obtaining and maintaining the target MSKC to CC timing relationship. In some embodiments, if the actual MSKC to CC timing relationship of the user determined in S540 is associated with MCP (the target relationship of S550), the system functions to provide a recurrent prompt to the user that maintains the user at that timing relationship. In some embodiments, the recurrent prompt provided in S520 may comprise an audible or tactile metronome beat or a musical beat, wherein the beat frequency corresponds to the prompt rate. Furthermore, the prompt rate may continue persistently at the same frequency when in step S560 no adjustments to the prompt timing are indicated or for up to a pre-defined period of time when signals from S500 and/or S530 and the computations of S540 become temporarily disrupted.

[0110] FIGS. 6A-G illustrate a series of PPG signals of a user 41, 42, 43, 46, 47 and 610, in accordance with a preferred embodiment. As described above, sensors utilizing plethysmography (e.g. PPG or IPG) may be used within a system to favorably coordinate a timing of a rhythmic MSKC of a user that repeats at a MSKR of the user with a timing of a CC of the user that repeats at a HR of the user. In general, plethysmography signals from a blood-perfused tissue include a pulsatile component ("AC") and a non-pulsatile component ("DC"), reflecting the short-term time varying changes in local blood volume and overall raw signal levels, respectively. As is the case in FIGS. 6A-G, plethysmography signals are typically presented graphically after normalizing (dividing) the signal by the recent average DC values to remove the influence of factors unrelated to the blood volume changes. The signal's "pulse amplitude" ($PA=100 \times AC/DC$ as a percentage, sometimes also referred to as percent modulation amplitude or perfusion index) is an indicator of pulsatile signal strength and correlates to the relative changes in blood volume in the underlying tissue. For example, the pulse amplitudes of the PPG signals plotted in FIGS. 6A-F vary between approximately 2% and 6%, corresponding to the peak-to-valley heights of the envelope.

[0111] In some embodiments, plethysmography may be used collectively to determine at least one of a CC rate, a CC timing, an MSKR, an MSKC timing, a MSKC to CC arterial blood flow or pressure interaction, a MSKC to CC timing relationship, a target MSKC to CC timing waveform, and a target MSKC to CC timing relationship, and may function to guide a user to a target MSKC to CC timing relationship. For example, a sensor of blood volume, pressure, or flow, such

as a PPG sensor, may be used alone or in combination with one or more additional CC or MSKC sensors to provide reliable identification, achievement, and maintenance of a target MSKC to CC timing relationship. For example, to derive a HR of a user using a PPG sensor alone, instances of at least one feature of the PPG signal that repeats at the HR of the user (e.g. peak regularly occurring signal amplitude, P, illustrated by peaks 31 in FIGS. 4A, 4C, and 6D) may be identified by a processor, with HR calculated from the recurring time interval between each instance (the heart's beat-to-beat or P-to-P interval), wherein $HR = \text{heartbeats/minute} = [1 \text{ minute} + (\text{beat-to-beat interval in minutes})]$.

[0112] In some embodiments, the same PPG signal may also be used to derive the MSKR during rhythmic physical activity by identifying instances of one or more features of the MSKC and CC wave interaction patterns in the PPG signal. For example, when two waves in the same system occur at different but similar frequencies, a characteristic beat pattern (FIG. 6A) may be created in which the waves repeatedly go back and forth between overlapping 46 (resonance) and separating 47, with a maximal beat wave amplitude happening when the two waves occur at the same time in the same location 46. In the event that the MSKC induced arterial pressure waves are from a single predominant rhythmic MSK pump, the resulting recurring increase and decrease in beat wave amplitude occurs at a beat frequency that is the difference in the frequency between the two separate recurring CC and MSKC induced waves. Therefore, once the HR has been calculated from data obtained via the PPG signal (as described, or via one or more other CC sensor systems), the MSKC frequency may be calculated by adding or subtracting the beat frequency of the PPG, which may be possible if the HR and MSKR are close enough to one another that the beat pattern of the overlapping MSKC and CC waves is identifiable. There are multiple simple ways to determine whether the beat frequency should be added or subtracted from the HR, for example, the wave morphology as seen in an asymmetrical shape of the beat pattern of the PPG, as shown in FIG. 6A, may be reversed when the MSKR is higher than the HR. Alternatively, an additional sensor, such as an accelerometer, may be used to identify a separate MSKR signal, which will be described in further detail below. In some embodiments, the relative timing, shape, and magnitude of the signals from pressure, volume, or flow sensors at different anatomical locations vary due to pulse transit times (on the order of tens to hundreds of milliseconds), with a magnitude that generally increases as a function of the sensor's distance from the blood pump that has generated the sensed change in signal. Conversely, electrical sensors (e.g. ECG, EMG, EEG) sense electrical signals that travel from their sources at nearly the speed of light. Thus, delays due to anatomical location are imperceptible and clinically irrelevant. The increase in the magnitude of the delay (pulse transit time) with the distance from the heart to the peripheral location at which the waveform is measured, means that, for example, an increase in the size of the individual (e.g. height or length of limb for a limb-based plethysmographic sensor) might be a factor in generally increasing pulse transit time in that individual over individuals of smaller size, all else being equal. Other factors may also influence arterial pulse transit time delays and wave morphologies, including vascular attributes (e.g. arterial stiffness, size), the type of MSK activity, blood

effects (e.g. volume, viscosity), and cardiac effects (e.g., contractility). These pulse transit time delays and other offsets may be accounted for in determining a target MSKC to CC timing relationship and/or in computing an actual MSKC to CC timing relationship.

[0113] FIG. 6A illustrates an exemplary PPG signal 41 observed at the forehead of a user running at a step rate slightly slower than the HR of the user. The slightly slower step rate of the user results in the user stepping, on average, slightly later in the CC with each step, as indicated by the points in 44 which indicate the MSKC to CC timing as a % RRI (0-100%) of each step of the user. As shown in FIG. 6A, the different contributing wave frequencies combine in the PPG to yield the observed beat phenomenon, wherein the peak arterial blood volume waves regularly oscillate in magnitude between maximal 46 and minimal 47 size at a rate per minute equal to the difference between the HR and the step rate. In some embodiments, beat phenomenon 46-47 is a result of the regular, simultaneous occurrence of separate arterial pressure wave peaks from MSK activity vascular pumping and the CC pumping. These separate pressure waves, created at different frequencies, cycle between being substantially separate 47 to being progressively more on top of one another and therefore substantially combined 46 then back again, repetitively, leading to regular oscillations in the magnitude of the periodic arterial blood volume, as shown in FIGS. 6A, D, F. Further, the frequency of the beat phenomenon may also be used as an input into a program or delivered to a processor that calculates the step rate once the HR is known, or calculates the HR once the step rate is known (e.g. from a separate accelerometer signal).

[0114] Further, additional characteristics of the PPG wave may reflect the actual timing of the MSKC relative to the timing of the CC. In some embodiments, signals may be processed to identify target PPG waveform characteristics and patterns that correspond to desired MSKC to CC timing relationships. For example, values that represent PPG morphology, overall DC signal amplitude, pulse amplitude, average amplitude, changes in amplitude, rates of changes in amplitude, and averages and progressions thereof, may be provided to a processor where they may be used to calculate a correction value for adjusting guidance to a user that, when generally followed by the user, functions to reduce the difference between the actual MSKC to CC timing relationship and the preferred MSKC to CC timing relationship. In one embodiment, a processor may initially calculate appropriate guidance of timing to guide the user to achieve an MSKC rate (e.g. step rate) that is substantially equal to HR. In another embodiment, such initial guidance is not provided, and the system initiates guidance once the PPG signal begins to exhibit general behaviors chosen as indicators that a preferred MSKC to CC timing would be readily achievable with user guidance.

[0115] In some embodiments, as shown in FIG. 6A, a periodic change in pulse amplitude of the PPG waveform may be present, indicating that the user is stepping at a timing relative to the CC timing that slowly changes over time during the rhythmic musculoskeletal activity. The processor may identify one or more characteristics of the PPG waveform that correlate with relative MSKC to CC timing (e.g. pulse amplitude), while simultaneously identifying a marker of optimal relative MSKC to CC timing, for example a reduced or minimum HR (HR_{min}) when compared to HR during an alternative MSKC to CC timing. As shown in the

exemplary PPG signals in FIG. 6C when the PPG amplitude is compared to recent PPG amplitudes 46 of FIG. 6A in the same user, the average PPG pulse amplitude is substantially at or near its local maximum value. In this example, maximal MSKC pumping of the user consistently occurred during early diastole per the step timing markers 44 shown in FIG. 6C. Therefore, in this example, a local maximum average pulse amplitude may be a reasonable target PPG morphology for guiding a user to MCP, representing a relative preferred value of the measured characteristic (pulse amplitude, in this example) of the signal.

[0116] Various methods may be used, alone or in combination, to identify a target PPG signal characteristic that is indicative of optimal MSKC to CC relative timing. Quantifying metrics that target these characteristics, such as the PPG pulse amplitude as just described, can be used as part of a feedback loop to provide appropriate guidance to a user. Other examples of characteristics and metrics include beat-to-beat PPG waveform symmetry, peak and valley curvature, and/or signal complexity. The analysis may utilize the raw signal or a first or second derivative of the signals considered in the time domain, or can be considered in the frequency domain, wavelet space, or other domain. In all cases, the purpose is to utilize metrics that, alone or in combination, correlate to the timing relationship between the MSKC and the CC of the user. Details of such methods will be described more fully through the use of examples below.

[0117] As shown in FIGS. 6C and 6D, a PPG morphology of a user is sustained at substantially maximum average pulse amplitude 46, with FIG. 6D representing a shorter time interval for better visualization of waveform morphologies. An accompanying accelerometer signal 48 in relation to the ECG R-Wave timing indicated by 45 and the calculated maximal MSK pump (step) timing 49 are shown in FIGS. 6D and 6E. FIGS. 6B and 6E illustrate a PPG morphology of a user when the PPG waveform 47 approaches a local minimum in pulse amplitude, with FIG. 6E representing a shorter time interval. In exemplary systems, as the HR and MSKC frequency are increasingly different, the beat frequency caused by the overlapping waves increases and becomes less and less distinct and more and more difficult to identify clearly. For example, it may become difficult to measure a beat frequency of 60 beats per minute, running at a stride frequency of 180 steps per minute, when the HR is only 120 beats per minute, because the beats can become increasingly obscured as the beat frequency continues to rise. Therefore, in some embodiments, a separate MSKC sensor, such as an accelerometer, for identification of an MSKC signal, as described above, may optionally be utilized to identify the MSKC frequency of the user during rhythmic physical activity.

[0118] To further illustrate the behaviors described above, FIGS. 6F and 6G show plots of simultaneously collected ECG 600, PPG 610, and accelerometer 620 signals of a user walking on a treadmill. To generate these signals, a PPG sensor was placed on the user's forehead, while simultaneous ECG and accelerometer signals were obtained with respective sensors placed on the user's chest. Horizontal line 630 represents the average accelerometer signal that is obtained when the user is not moving (i.e., approximately equivalent to 1 g, the acceleration due to gravity). As shown in FIG. 6F, the user's MSK pump timing (step timing), as indicated by the points 640, where the largest upslope during

each MSKC of the accelerometer signal 620 crosses the horizontal line 630, occurs at approximately 40% of the RRI, using R-wave events 24 (FIG. 4B) as the timing marker for the CC. In this example of a relative MSKC to CC timing of 40% of the RRI, the PPG waveform 610 exhibits a morphology comprising a smooth rounded upper portion and a more-flattened lower portion, as shown in FIG. 6F.

[0119] FIG. 6G illustrates changes in PPG signal 610 when the user steps at an MSKC to CC timing closer to 0% RRI. The waveform shape of signal 610 in FIG. 6G differs from the same signal in FIG. 6F, namely the upper portion is more flattened and the bottom is more rounded. Beyond the pulse amplitude as described above, these resulting morphologic differences in the PPG signals 610 in FIGS. 6F and 6G, seen also in FIGS. 6A-6E, may be used by the system to characterize the general degree of coordination between the MSKC and CC blood pumps, since the different waveform shapes correlate directly to the actual MSKC to CC timing relationship of the user. Such characterization of the morphology may be computed in a variety of ways, as will be described more fully below.

[0120] FIGS. 6G-F also represent signals from exemplary systems and methods that characterize an observed CC timing relationship with respect to an actual CC central blood pump timing of a user as a step in calculating a pulse transit time and/or assisting in calibration of the system for a specific user. For example, a PPG sensor at a specific peripheral location may be compared to a simultaneous ECG signal of the user in order to calibrate the system such that the true CC timing can be more accurately characterized with a PPG sensor alone after the user is no longer contacting both ECG leads.

[0121] As is illustrated in FIGS. 21 and 22, in some embodiments of the system and method, the pulse transit time of a sensed arterial pressure wave can be determined on a processor by comparing an aspect of a plethysmographic signal that repeats at the HR of the user (the CC timing signal of a plethysmogram) from a peripherally-mounted sensor (e.g., on the wrist or head of a user) to the timing of a simultaneous ECG signal. In example embodiments, as shown in FIG. 21, a PPG and/or IPG sensor 2110 in a device mounted on the wrist 2100 may be used simultaneously with an ECG sensor also in the same wrist-based system, with a first electrode continuously contacting the wrist of the user 2120, and a second electrode 2130 on an externally facing surface of the same device. The user may complete the ECG circuit 2140 by touching a finger of their opposite hand to the second electrode 2130 of the sensor, so that the ECG signal may be measured and an ECG CC timing determined on a processor, for comparison to the simultaneously measured plethysmographic CC signal timing, on the same processor or a different processor.

[0122] Alternatively, in another exemplary embodiment as shown in FIG. 22, an ear-based device 2200 may include one or more sensors of blood pressure, volume or flow 2210 (e.g. plethysmographic) as well as a pair of electrodes, one in contact with the skin of the head or ear of the user 2220, and the other insulated from the tissue of the head or ear, but accessible to the touch of the user's hand 2230, as shown in FIG. 22. In such exemplary embodiments, the user may touch the exposed electrode 2230 with the skin of a finger, as shown in FIG. 22, for example a finger of the user's left hand when touching a head-based device, in order to com-

plete the ECG circuit **2240** and measure the ECG and PPG signals simultaneously for comparison of their CC signals of CC timing.

[0123] FIG. 7A illustrates a flow chart for favorably coordinating a timing relationship between an MSKC of a rhythmic musculoskeletal activity of a user and a CC of the user using a sensor to provide signals that correlate to a cyclically-varying arterial blood volume in a tissue of the user, for example, a plethysmography sensor. As shown in FIG. 7A, a preferred method of favorably coordinating a timing relationship between an MSKC of a rhythmic musculoskeletal activity of a user and a CC of the user includes the steps of recurrently providing a movement guidance from a prompt device to the user for guiding performance of the rhythmic musculoskeletal activity **S700a**; detecting a signal, using a sensor, that correlates to a cyclically-varying arterial blood volume in a tissue of the user **S710a**; determining an actual value of a measured characteristic of the signal that varies with the timing relationship between the MSKC and the CC of the user **S720a**; computing a trend of the actual value of the measured characteristic using a processor **S730a**; and adjusting the movement guidance based on the trend of the actual value of the measured characteristic so as to cause the actual value of the measured characteristic to approach a relative preferred value of the measured characteristic **S740a**. This process continues by returning after step **S740a** to step **S710a** in a repetitive manner, for example, repeating for a duration of an exercise, or as long as certain exercise or physiological data are maintained, or for a predetermined period of time.

[0124] In some embodiments, the methods of FIGS. 7A-B may include a calibration process. The calibration process may include the steps of detecting a second characteristic of the signal or one or more additional signals corresponding to a physiological metric that varies with the timing relationship between the MSKC and the CC of the user, using the sensor or one or more additional sensors, and determining the relative preferred value of the measured characteristic as a relative value of the trend that corresponds with a preferred value of the physiological metric. Further examples of such calibration processes are provided below in the section titled Calibration Methods. In exemplary embodiments, the movement guidance comprises an audible, visual, or tactile prompt. In example implementations, the movement guidance prompts the user in at least one of MSK activity timing and MSK activity effort. For example, activity timing guidance may provide the prompt to the user at a prompt rate, such that the HR of the user is substantially an integer multiple of the prompt rate, and adjusting the movement guidance means adjusting the prompt rate. In other exemplary embodiments, adjusting the movement guidance means guiding the user to alter a stride length during running or walking; to change a gear while riding a bicycle; to change a distance of movement, resistance, or incline using exercise equipment; or to modify a stroke length during rowing or swimming, in each case in order to modify their effort at a given MSKC frequency.

[0125] In certain embodiments, the relative preferred value is a target behavior of the trend of the value of the measured characteristic and further adjusting the guidance based on a difference between trend of the actual value and the relative preferred value of the measured characteristic guides the user towards substantially obtaining and maintaining the relative preferred value (“target behavior”) of the

measured characteristic. For example, a target behavior of the trend of the value of the measured characteristic of a PPG waveform may include preferred behaviors such as, for example, at least one of an increasing pulse amplitude, a decreasing waveform complexity, and a change in timing of an aspect of the PPG signal that repeats at a HR of the user towards a target timing relationship relative to an aspect of an MSKC timing signal that repeats at an MSKR of the user.

[0126] In additional embodiments of the method, the relative preferred value may be a target value of the measured characteristic, said target value corresponding to the target timing relationship between the MSKC and the CC of the user. For example, a target value of a PPG waveform may include exemplary preferred relative values such as at least one of local maximum pulse amplitude, a local minimum waveform complexity, and a target timing relationship of an aspect of the PPG signal that repeats at a HR of the user relative to an aspect of an MSKC timing signal that repeats at an MSKR of the user. FIG. 7B illustrates another flow chart for favorably coordinating a timing of a rhythmic MSKC with a timing of a CC of a user using a sensor that provides signals that correlate to the cyclically-varying arterial blood volume in a tissue of the user, such as, for example, a plethysmography sensor (e.g. PPG or IPG), in accordance with a preferred embodiment. Exemplary steps include the repetitive cycle of detecting a signal, using a sensor, responsive to cyclically varying blood volume in a tissue of the user **S700b**; determining a first measured characteristic of the signal that repeats at a HR of the user and determining the HR of the user from the first characteristic **S710b**; recurrently providing a guidance prompt from a prompt device to the user as a timing indication for performance of a rhythmic MSK activity, wherein the HR is an integer multiple of the rate of the timing indication **720b**; determining a value of a second measured characteristic of the signal that varies with an actual MSKC to CC timing relationship of the user **730b**; and adjusting the guidance based on a trend of the value of the second measured characteristic towards a relative preferred value of the second measured characteristic corresponding to a target MSKC to CC timing relationship, thereby guiding the user towards substantially obtaining and maintaining the target timing relationship **740b**. After completion of step **S740b**, the process loops back to **S700b**, making the process repetitive, repeating, for example, for a duration of an exercise or a predetermined period of time.

[0127] In an exemplary embodiment, the detected signal **S700b** may comprise a PPG signal, and the first measured characteristic that repeats at the HR of the user **710b** may be the peaks of the signal that correspond with systolic arterial pressure **31** (FIG. 6E). In certain exemplary embodiments wherein the detected signal **S700b** is a PPG signal, the first measured characteristic **710b** may be available to correlate to the HR of a user only intermittently, but for adequate durations to calculate a HR of a user. For example, referring to the beat phenomenon illustrated in FIG. 6A, the first measured characteristic **710b** may be the regularly occurring peaks of the signal that equal or surpass a predefined or relative amplitude or shape characteristic (such as seen in FIG. 6D, 46), because, for example, the larger and/or sharper systolic peaks in the PPG may be easier to identify reliably. An exemplary signal with intermittently oscillating PPG amplitudes is illustrated in FIG. 6A, wherein the relatively larger and easier to identify systolic peaks **31**, magnified in

FIG. 6D, may be more accessible for reliable interpretation than the relatively smaller and potentially more difficult to identify systolic peaks 31 in FIG. 6E.

[0128] Alternative embodiments of the method of FIG. 7B may alternatively or additionally leverage a measured characteristic that is different from the first measured characteristic described in step S710b in order to determine the HR of the user. For example, if the value of the MSKR is available from another sensor (e.g. accelerometer), then the frequency of the beat phenomenon, as illustrated in FIG. 6A, may be measured from the PPG signal and then added to or subtracted from the value of the MSKR in order to obtain the value of the HR. In further embodiments, CC timing measurements, for example using plethysmography or electrocardiography, can be improved by measuring signals sensitive to the MSKC, such as through the use of an accelerometer, and incorporating these signal values into a noise cancellation or attenuation methodology. In further exemplary implementations of FIG. 7B, adjusting the guidance means adjusting the prompt rate. In yet other exemplary embodiments, adjusting the guidance includes guiding the user to alter effort at a given MSKC frequency (e.g. alter stride or stroke length at a given MSKC cadence, incline or resistance on an exercise device, etc.).

[0129] Referring now to the flowcharts shown in FIGS. 7A and 7B, in some embodiments, the measured characteristic S720a and second measured characteristic S730b may include a pulse amplitude of a plethysmography signal detected in S710a and S700b, respectively, as is illustrated by the exemplary PPG signal in FIG. 6 and as was described above. Alternatively or additionally, in some embodiments, the measured characteristics S720a and S730b may include a measure of the complexity of the signal from the sensor. The amount of smoothness or “noise” in a waveform relates to the complexity of the signal. For example, in certain circumstances, when the CC and MSKC contributions to blood volume in the local tissue at the measurement site are cycling with each other constructively, the pulse amplitude is greatest, as shown by waveform 46 in FIGS. 6A and 6D, and the waveform is generally smooth or substantially sinusoidal, resulting in reduced complexity. Conversely, when the CC and MSKC contributions are out of alignment, there is an appearance of extra features in the waveform (over the timing of one complete CC) resulting in increased complexity, such as seen by 47 in FIG. 6E.

[0130] In further embodiments, the asymmetry of the sensed signal waveforms may be analyzed with a processor in order to determine additional timing information, for example, to determine whether the MSK timing is occurring slightly early relative to a target timing relationship or slightly late relative to a target timing relationship. Additionally or alternatively, the measured characteristic of the signal may be computed using a combination of two or more unique characteristics of the signal that vary with the timing relationship between the MSKC and the CC of the user. For example, at least one of the trends in changes of aspects of the complexity, amplitude, and symmetry of the PPG signal may be identified and utilized simultaneously in the steps of determining a value of a second measured characteristic S730b, as described in FIG. 7B, or in computing a trend of the actual value of the measured characteristic on a processor S730a, as described in FIG. 7B. In one such embodiment, target characteristics of a PPG signal on the head of a user may include a target combination of both maximal

relative pulse amplitude plus minimal signal complexity. In other embodiments, the measured characteristic may include the relative phase between the two contributing signals as computed, for example, using a Fourier transform and retaining the complex term (phase). In yet another example embodiment, the characteristic may be a measure of the number of inflection points of the waveform per cycle of the MSKC or CC. As noted above with respect to waveforms 610 in FIGS. 6F-G, another measured characteristic that may be considered alone or in combination may include the relative curvature of the PPG peaks and valleys, quantified for example by computing a ratio of the relative amount of change in signal amplitude adjacent to the peak signal to the amount of change adjacent to the valley, considered over individual cycles in the PPG.

[0131] Steps 730a and 730b include determining an actual value of the measured characteristic of the signal that varies with the timing relationship between the MSKC to CC of the user. The trend may be computed as the difference in the value observed, or a series of values observed, at two or more different times, such as the most recently observed value and the value available immediately preceding it, or alternatively, the average change over several recent sample periods. Considering the PPG signal 41 of FIG. 6A, the trend of the pulse amplitude can be seen to oscillate approximately seven times over the duration of the graph. In the final seconds of the graph in FIG. 6A, the most recent trend exhibits the behavior of a decreasing pulse amplitude, and a decreasing average pulse amplitude. Steps S740a and S740b include a relative preferred value of the measured characteristic corresponding to a target relative MSKC to CC timing. The term “relative preferred value” used in conjunction with FIG. 7 refers to a preferred value of the measured characteristic in comparison to the value of recent instances of the characteristic, or equivalently, a preferred relationship of the actual value of the measured characteristic relative to the trend of the value of the measured characteristic, as is described more fully below. This preferred relationship may correlate with an MSKC to CC timing relationship consistent with MCP.

[0132] In some embodiments, the target MSKC to CC timing may target the condition of MCP. The value of the measured characteristic corresponding to this condition may depend on the nature of the signals detected in S710a and S700b and where on the body the sensor is located. In one embodiment, the relative preferred value of the measured characteristic during MCP may correspond to a pulse amplitude of an observed plethysmography signal exhibiting a behavior of reaching its local instantaneous maximum in its trend over the recent history of the observed pulse amplitude. Alternatively, the relative preferred value may correspond to a local maximum in the average of the pulse amplitude compared to its recent history. In other embodiments, a local minimum in the trend of the pulse amplitude may be associated with MCP, or an average maximum pulse amplitude minus the average minimum pulse amplitude over a given rolling window of time. Similarly, in yet another embodiment, the relative preferred value may correspond to a local minimum complexity in the PPG signal. Alternatively, the relative preferred value may correspond to a local maximum complexity in comparison to its recent history. In further exemplary embodiments, the relative preferred value may correspond to a maximal local average of the absolute values of the derivative of the PPG signal or to a minimal

local average of the absolute values of the second derivatives of the PPG signal. In other embodiments, the trend of the measured characteristic may be used to identify a specific relative value of the measured characteristic corresponding, for example, to the value of a local maximum or, in another example, a value of a local minimum in the trend. The system may then adjust the guidance based on a difference between the actual value of the measured characteristic and this previously identified specific relative value from the trend. In another example embodiment, the relative value of the measured characteristic may correspond to a point in the trend when the value changes sign from negative to positive, or in a different example, from positive to negative, crossing a threshold value of zero either in a positive slope of the trend or a negative slope in the trend, respectively. In some embodiments, the relative preferred value corresponding to a target MSKC to CC timing is determined empirically according to a calibration process, which is described more fully below.

[0133] In an exemplary system, the user is provided with a guidance prompt comprising a metronome that repeats at a rate that matches an expected HR of the user during their rhythmic activity. The user times their rhythmic activity to occur with the metronome, and as the user's HR approaches this rate, a PPG signal measured on the user, such as in FIG. 6A, begins to exhibit a behavior of a cycling pulse amplitude (pulse amplitude representing the measured characteristic of the signal). Considering a relative preferred value of the measured characteristic to correspond to a local maximum in the pulse amplitude, the system may increase the period of the metronome when the trend of actual value of the measured pulse amplitude stops increasing over time and begins to decrease. If the trend of the pulse amplitude responds to the change in metronome by increasing, the metronome period continues unchanged. When the pulse amplitude again begins to decrease, having passed its local maximum, the system decreases the metronome period so as to reverse the trend in the decreasing pulse amplitude, thereby causing the pulse amplitude to approach the relative preferred value and substantially maintain the target timing relationship between the user's MSKC and CC.

[0134] In addition to the steps illustrated in FIGS. 7A and 7B, in order to obtain an MSKR, embodiments may include a second signal from a second sensor responsive to the MSKC of the user, for example, an accelerometer signal 48 from an accelerometer, as shown in FIGS. 6D and 6E, may be used.

[0135] In certain embodiments, one of the characteristics of the signal that correlates to a cyclically varying arterial blood volume in a tissue of the user may be a timing of a recurrent aspect of the signal that varies with the HR of the user, which may be used alone or in combination with exemplary measured characteristics of the signal previously described. For example, relatively high pulse amplitude may be one preferred measured characteristic of a PPG signal in a tissue on the head of a user indicating that the MSKC to CC timing relationship is approaching a preferred MSKC to CC timing relationship. In this example, pulse peak timing at the higher pulse amplitude may be an aspect of the signal that correlates with a CC timing, such that the timing of the CC can thereby be compared to the timing of the MSKC detected from a second sensor (e.g. accelerometer), and these signal timings can be used to determine both a measured and an actual MSKC to CC timing relationship using

a processor, wherein, for example, the actual timing relationship is corrected for pulse transit time. The timing indication of the prompt may then be adjusted, as indicated, based on a difference between the actual timing relationship and the preferred timing relationship, so as to reduce the magnitude of the difference.

[0136] In some embodiments, the method of FIGS. 7A and 7B may further include providing MSK activity guidance or adjusting MSK activity guidance only when the absolute value of a difference between the musculoskeletal activity cycle rate (MSKR) and HR is less than, or less than or equal to, the specified allowable difference.

[0137] Now turning to exemplary exercise equipment systems for implementing systems and methods described herein. FIG. 8 illustrates the basic components of a system 200 for use according to the methods described more fully below. Sensors 204 and 208 are responsive to the user's CC and MSKC, respectively, and provide their associated signals via connections 206 and 210 to a microprocessor and/or controller 212. User interface 214 allows the user to input to the system configurable run-time settings according to their preferences (e.g., selection of operating mode, target HR, HR alert zones, running display characteristics, enabling or disabling logging), as well as means to provide an output of visual, audible, and/or tactile information during their activity (e.g., whether step controlling is active or inactive, and indication of the user's HR, cadence, and/or relative MSKC-CC timing in real-time or as a trend display). Interface 214 may further include a link to another device such as a computer, smartphone, smart-watch, smart-glasses, exercise equipment interface, or other remote device; or through a dedicated interface to the current device such as a touchscreen, switches, etc.

[0138] The processor/controller 212 processes the signals from 204 and 208 to determine the relative MSKC to CC timing relationship of the user and determines its difference compared to a targeted relative timing value (these processes and targeted values will be described more fully below). The difference is then used to determine needed adjustments to the exercise equipment 218 to correct a sensed error relative to the targeted value. The processor/controller 212 is linked to the exercise equipment 218 through an exercise equipment interface 216 for transmitting and receiving the associated signals and/or commands needed to function according to the current methods. Any or all of the components indicated in FIG. 8 can be physically housed or incorporated by function into the exercise equipment, or alternatively included in one or more separate packaged device(s). Furthermore, any or all of the lines 206, 210, 220, 222 and 224 linking unique componentry can be accomplished through wired and/or wireless communications alone or in combination.

[0139] FIG. 9 illustrates the system 200 of FIG. 8 in more detail. CC sensor 204, in one example, comprises an ECG lead 304 that includes at least two electrodes in electrical contact with the user. In another example, CC sensor 204 comprises a photoplethysmography (PPG) sensor 306 that includes a light source, such as an LED, and a photodetector, with one, both, or neither of the two components in contact with the user's skin at a blood perfused tissue location such as on the user's forehead, temple, ear, or other suitable PPG location. There are yet further alternative transducing methods available for CC sensor 204, including impedance plethysmography (IPG), infrared or visible light based video

cameras that detect changes in the skin color or optical reflectance with each heartbeat, electronic auscultation using a microphone, auscultation, ultrasound, sonar, radar, or by detecting any other signal that correlates directly in real-time with the user's cardiac cycle. Any required transducer drive currents, voltages and signals, as well as conditioning and possibly digitizing of the received signals, may be provided by front end 314, which serves to provide an interface between sensors 204 and 208 and processor/controller 212.

[0140] MSKC sensor 208 in system 300, in one example, comprises an accelerometer 308 located on the user (on the chest, back, side, waist, head, arm, leg, etc.) such that changes in the monitored signals track with the user's repetitive movements; or on the exercise equipment, provided movements of the equipment relate specifically to the user's MSKC timing. Examples of such suitable equipment locations include the crank of a bicycle or foot platform of an elliptical exercise apparatus, as the acceleration of these locations cycle in synchrony with the user's repetitive movements. Further examples of MSKC sensor 208 options are shown in FIG. 9 as an optical or mechanical switch 310 or strain gauge 312 (configured for sensing changes in stress, force, or pressure). Any of these sensors 308, 310, or 312 would be appropriately mounted on exercise equipment 218 so as to change state or signal level in synchrony with each cycle of the user's repetitive movements. Yet further alternative signal transducers for sensing the MSKC timing include magnetometers, gyroscopes, proximity sensors, video cameras, or any other device that generates a signal with a direct correlation in real time to the user's MSKC. In general, sensors responsive to the user's CC cycle and/or MSKC activity may be directly attached to the user, attached to the exercise equipment, or mounted remote to the user and/or equipment.

[0141] In some implementations of systems 200 or 300, a single transducer may provide the functionality of both of the CC and MSKC activity sensors. For example, signals from a PPG sensor may be used by the system to identify characteristics associated with the relative MSKC and CC pump timing, such as by numerically characterizing the signal pulse amplitude or waveform morphology. In general, signals from any transducer responsive to peripheral intravascular blood volume, pressure or flow can be used to identify characteristics of the timing, relative timing and magnitude of both CC and MSKC blood pumps.

[0142] Because systems 200 and 300 shown in FIGS. 2 and 3 are used, in part, to determine the user's relative MSKC and CC timing relationship in an ongoing manner, it is important that the hardware timing relationship of the transmitted signals coming from two or more signal transducers are understood and/or controlled. For example, if the MSKC and CC signals are acquired based on the timing of different clocks, or if one or both signals are sent wirelessly to the processor controller, any drifting of the clocking signals or latency in the signal transmission may influence the sensed relative MSKC-to-CC timing relationship. Preferably, the sensed MSKC and CC event times are based on a common clocking signal, or alternatively, synchronized clocks so as to maintain a stable hardware influence on the sensed physiologic relationship.

[0143] Systems 200 and 300 include means for adjusting the settings or behaviors of exercise equipment 218 through interface 216. Such adjustments may include, for example, at least one of a change in: treadmill track speed, resistance,

or incline; elliptical resistance, cadence, or stride length; bicycle resistance, gearing, or crank length; rowing resistance or stroke length. As can be appreciated, these examples target factors in the respective equipment's settings that can affect a user's activity cadence and/or HR. Furthermore, the adjustments can be made in a magnitude and/or duration sufficient to quickly correct sensed errors in the user's relative MSKC-CC timing with respect to a targeted timing relationship or, alternatively, small enough so as to be relatively imperceptible to the user. The electro-mechanical components used to induce changes to the exercise equipment may be additional components added specifically for the purpose of implementing system 200 or 300; or may already be included as part of the exercise equipment, with interface 216 used to communicate with the controllers of such components already in place.

[0144] FIG. 10 illustrates a treadmill system for sensing a CC and MSKC timing of a user and guiding a user to the target MSKC to CC timing relationship, in accordance with an embodiment. A treadmill system, as shown in FIG. 10, may be used to determine a target MSKC to CC timing relationship, as well as to guide a user to the target MSKC to CC timing relationship. As shown in FIG. 10, the treadmill system 800 may include a user input interface 801, a processor/controller 810, an exercise equipment interface 816, a user guidance interface 820, a motor driver 813, an incline driver 818, and a track 822 on which the user 808 may run or walk. The treadmill system 800 may include a chest strap 809 for measuring the CC of the user 808 with CC sensor 812. Alternatively, any type of wearable sensor or device may be worn by the user to measure a CC of the user, for example a smart watch and/or a chest strap 809 with HR and/or MSKC sensor. The MSKC of the user may be measured in one embodiment by using sensor 811 included, for example, within chest strap 809, or in another embodiment as a component of the treadmill such as load cell 814 or an accelerometer. In yet another embodiment, a single sensor, combining the function of sensors 811 and 812, may be used for sensing both the CC and MSKC of the user or, for example a PPG sensor, as was described more fully above. The functioning and embodiments of the user input interface 801, CC signal sensor 812, MSKC sensor 811 or 814, processor 810, and exercise equipment interface 816 were described above in connection with FIGS. 1 and 2.

[0145] As shown in FIG. 10, an MSKC sensor 814, for example a load sensor, may be used to sense the load of the user 808 as a foot of the user strikes the track 822 of the treadmill 804. In some embodiments, the information collected by the MSKC sensor and CC sensor may be transmitted to the processor for determining the actual and target MSKC to CC timing relationships, as described above. Sensor 814 represents one example of a location and type of MSKC sensor that can be used with the exercise equipment. In addition to the body-worn MSKC sensors described previously, other examples of MSKC sensors on the equipment include vibration, switch, optical, video, and pressure sensors, or any others well known in the exercise equipment industry. In further embodiments, a computer, for example, a tablet computer, may be placed on or attached to the exercise equipment, said computer including or communicating with at least one of an MSKC sensor (e.g. accelerometer or user facing camera) and a CC sensor (e.g. user facing camera).

[0146] Also as shown in FIG. 10, an exercise equipment interface 816, user input interface 801, or user guidance interface 820 may be used by a user or automatically controlled by the processor 810 to adjust the motor driver 813 to increase or decrease speed and the incline driver 818 to raise or lower the incline of track 822. Further, additional sensors may be used to detect hand gestures or other body movements that are recognized as commands for adjusting the treadmill incline, treadmill speed, type of music, playlist selection, volume control, type of graphical display, graphical display selection, or any other type of controls. In some embodiments, one or more automation features may be used to guide a user towards a target MSKC to CC timing relationship, for example using the user guidance interface 820. Alternatively, a user may abort an automatic setting or turn off an automatic setting to enable manual control of the motor driver 813 and incline driver 818 or any other feature of the treadmill.

[0147] In some embodiments, exercise equipment interface 816, user input interface 801, or user guidance interface 820 may also provide visual displays of information, such as raw data, processed data, or a combination thereof. For example, a HR, ECG, EEG, estimations of fat or sugar metabolism, blood insulin concentration, blood glucose concentration, step rate, MCP of the arms and/or legs, tissue lactate concentration, watts per beat, meters per beat, distance, and heel strike of a user may be displayed on the interface 801, 816, 820. In some embodiments, user guidance interface 820 may be used to provide guidance to the user. Guidance may be provided in an audible cue, visual display, tactile feedback, or other features that alert the user to a change in guidance, for example to increase or decrease stride length; to guide the user towards stepping every 2 beats, 3 beats, or 4 beats; or to coach the user to improve MSKC timing, concentration, or effort. As described above, reaching a target MSKC to CC timing relationship and other desired physical states, including desired HRs and MSK activity levels may be accomplished with treadmill system 800.

[0148] FIGS. 11 and 12 further illustrate examples of system configurations applied to a treadmill 404. In the example system shown in FIG. 11, user 408 wears a chest strap 410 that includes a CC sensor comprising an ECG lead. The strap further includes electrical circuitry to transduce and condition the ECG signal and transmit the signal data wirelessly. One such chest strap assembly is available commercially from Zephyr Technology (Annapolis, Md., USA; Zephyr Bioharness 3), though other comparable devices may be used. The ECG signals from 410 are received by CC signal receiver 412 and processed by processor/controller 212 for determining the timing of the users CC. The MSKC timing in system 400 is sensed using signals from load cell 414 positioned beneath one or more of the feet of treadmill 404. The amount of force applied to load cell 414 varies over time in synchrony with each step of user 408 while they are running or walking. Processor/controller 212 processes the signals and identifies the timing of each step, in one example, by using the signal associated with the onset of increasing force or, in another example, as the point in time of maximal force during each stepping cycle. Processor/controller 212 determines the relative timing of CC and MSKC signals, its difference with respect to a targeted value, and determines any needed corrective actions to reduce the magnitude of the difference. These corrective

actions are then implemented through exercise equipment interface 216 to change the speed of the treadmill through motor driver 416 and/or the incline of the treadmill through incline driver 418.

[0149] FIG. 12 provides another example of a system for use with a treadmill. In system 500 of FIG. 12, CC sensor 204, MSKC sensor 208, front end 314 and processor/controller 212 are all packaged in one or more housings 504 worn by user 408. As shown in system 500, these components are housed in a hat 506. In this example, CC sensor 204 comprises a PPG sensor (306) and may be located at user 408's forehead, temple, or on or in their ear; and MSKC sensor 208 comprises an accelerometer (308). Communications between processor/controller 212 and exercise equipment 218 is done wirelessly through transmitter/receiver (Tx/Rx) 508 and 510, respectively, as is communication with user interface 512. Interfaces 510 and 512 operate in a comparable manner as 216 and 214, respectively, though include provisions for the wireless communication.

[0150] Turning to FIG. 13, FIG. 13 illustrates a biking system 900 including an exercise equipment interface, user input interface, or user guidance interface 907 for sensing a CC and MSKC timing of a user 908 and guiding the user to a target MSKC to CC timing relationship, in accordance with an alternative embodiment. As shown in FIG. 13, one or more sensors may be integrated with one or more components of a bike, such as a pedal, tire, crank, hub, spoke, derailleur, or bike chain to obtain measurements of speed, distance, acceleration, power, etc., and to determine relationships with other physiological metrics. As shown in FIG. 13, a stationary bike may include a sensor 902 on the back frame tube 904, a sensor 910 on a second frame tube 909, a sensor on the pedal 905, a first foot sensor on the first pedal crank 906, and a second foot sensor (not shown) on the second pedal crank. One or more of the bike sensors as described above may be used to identify an actual or a preferred MSKC timing. For example, each revolution of the pedal may equal one MSKC, or may equal two, including one MSKC for each leg. In some embodiments, the signals from the one or more MSKC sensors on the bike may be compared to the timing of signals from at least one sensor worn by the user, for example a chest strap sensor 911 to sense a CC of the user 908. Comparison of a body worn ECG based CC sensor to an exercise equipment based CC sensor may be useful in calibration of embodiments of the system. Alternatively, a chest patch sensor, an implanted sensor, a wrist-based sensor, a head-based sensor, or another device previously described above may be worn by the user to measure a CC and/or MSKC of the user. Thus, for example, body versus pedal MSKC timing information may be determined and synchronized according to embodiments of exercise equipment as described herein. In some embodiments, synchronizing body versus pedal MSKC timing may require a characterization step, as will be described below. Alternatively, a sensed body movement metric may be determined and synchronized in order to calibrate the system MSKC pump timing. In some embodiments, synchronization or characterization of clocks on sensors, may be done using one or more accelerometers. Synchronization and characterization may require the user to perform coordinated actions that register distinguishable events in the data provided by the sensors, such that the distinguishable events may be used for correlating internal clocks of the sensors.

[0151] For a non-stationary or stationary bike, as shown in FIG. 13, exemplary embodiments of characterization algorithms include use of a body versus body MSKC sensor timing comparison. Further embodiments include a body MSKC sensor versus bike MSKC sensor timing comparison, each having an internal clock. In some embodiments, syncing the two clocks intermittently may be performed to characterize or check characterization at periodic events such as on the occasion that the user stands up on the pedals during MSKC. For example, this characterization maneuver may be a required step every few minutes during the use of the system. The characterization maneuver may incorporate two identical chip and accelerometer configurations (e.g. chest strap and bike crank) to correct for clock drift.

[0152] FIG. 14 further illustrates an example system 600 for use with a stationary bicycle 604. User 408 wears a chest strap 608 that includes an ECG lead for sensing their CC timing, and a wireless transmitter and/or transmitter/receiver. The MSKC timing of user 408, associated with their pedaling in this example, is sensed when one or both cranks 606a and 606b passes a proximity sensor 608 mounted to the seat tube 610 or, alternatively, the down tube 612. Depending on the nature of proximity sensor 608 used, affiliated component(s) 614 may be attached to one or both cranks 606 (e.g., a magnet or optical reflector). An alternative example of MSKC sensor 208 comprises a 2- or 3-axis accelerometer mounted directly to the crank, with signals from one or both of the two axes in the plane of the crank used for identifying the crank location. In example system 600, the pedaling resistance is adjusted by an electronically controlled variable resistance brake 616, controlled by processor/controller 212 and exercise equipment interface 218, to alter the MSKC timing of user 408 as needed.

[0153] A block diagram of the basic closed loop control system 1700 according to the present disclosure is shown in FIG. 15. The process begins by sensing the user's respective CC 1704 and MSKC timing 1706. These repetitive time-dependent values are then used to determine the relative MSKC-CC timing relationship. In one example, the CC and MSKC event times 24 and 35 (shown in FIGS. 4B-4C) coincide with one another (0% RRI); and in another example, the MSKC events 34 occur halfway between two consecutive CC events 24 (50% RRI). This sensed relative timing value is compared to a targeted relative timing relationship 1708 (established outside of this loop) to compute a difference value 1710. The difference value 1710, which represents an "error" between the sensed timing relationship and the targeted timing relationship, is then used to determine a correction value 1712 and an associated change to one or more settings or behaviors of the exercise equipment. This change in setting(s) will, in turn, affect the user's relative MSKC-CC timing and, accordingly, have an effect to reduce the magnitude of the error (decrease the absolute difference value). Once the correction is determined and implemented on the equipment 1714, the process loops back to the beginning and repeats.

[0154] As shown in control loop 1800 of FIG. 16, determining the relative MSKC-CC timing in 1812 from the available CC and MSKC signals 1804 and 1806, respectively, may further include signal validation steps 1808 and 1810. Such validation is helpful in ensuring that the measured error values 1812 and correction values in 1712 used in making adjustments to the equipment 1714 (if needed) are based on valid sensed readings and not false readings caused

by signal noise or other artifacts. Examples of validating include accepting only signals that are within a specified range of the recent average magnitude, and/or event times that occur within a specified range of the recent average event-to-event times. Other signals may be rejected and not used in steps 1812, 1712, and 1714, with the process continuing to loop without making adjustments to the exercise equipment until valid signals are again acquired.

[0155] Methods used for detecting MSKC events 34 depend on the type of activity being conducted, the exercise equipment being used, and the type and location of the MSKC signal transducer. Similarly, methods used for detecting CC timing events, such as 24, depend on the nature of the signal transducer used. FIG. 17 illustrates ECG 1904 and vertical axis accelerometer signals 1906 obtained on a user wearing a chest strap-based monitor while running. CC timing events 1704 or 1808 in this case can be determined by the system using the ECG signal 1904 by identifying the timing of a feature within the signal, such as the distinctive R-waves 24 that occur once per cardiac cycle. Alternatively, the system can use a PPG signal acquired from a sensor located, for example, on an adequately blood perfused tissue. Though not shown here, the signal has an appearance generally similar to arterial pressure waveform 32; the CC timing can be identified by the system as the signal associated with the peak within each cycle, or the valley, or the peak of the first derivative (the steep rise in the signal between end of diastole and systole)—each representing features that occur at close to the same point in time within the user's CC, and repeat at the user's HR.

[0156] Returning to FIG. 17, MSKC events 34 can be defined as the points in time when the positive-sloped portion of vertical axis signal 1906 crosses the signal's overall midpoint 1908 (i.e., the value similarly observed when the user is standing still, which will represent approximately +1 g). The signal line 1906 represents the raw accelerometer signal, while line 1910 is a centered boxcar-filtered value, used to attenuate the higher-frequency components of the signal. Note that the points in time where 1906 and 1910 cross the midline 1908 differ slightly. In another example for detecting MSKC events 34, a force transducer can be used and located on the base of the treadmill, such as load cell 414 in FIG. 11, with events 34 defined as the points when the force signal increases above a defined threshold or, in an alternative example, the points of local maxima in the signal. In another example, for exercise equipment that includes a reciprocating, oscillating or rotating element with a known and fixed relationship to the user's repetitive movements (e.g., a wheel, shaft, crank, or lever arm associated with a bicycle, stepper, elliptical, or rowing machine), a proximity sensor such as 608 as shown in FIG. 14, or accelerometer or other suitable transducer may be used to identify the cycle timing of the user's MSK repetitive movements. With each of these examples, specific features within the available signals occur once per MSKC, at close to the same point in time within each cycle and, accordingly, can be used to identify the blood pump timing of the repetitive MSKC. In some cases, depending on the design and type of equipment used, this sensed cycle timing may not occur with a 1:1 timing relationship to the user's MSKC, instead occurring with a 1:2 (every other MSKC), 2:1 (twice per MSKC), or other fixed relationship. This known relationship can be factored into the targeted relative MSKC-CC timing relationships described above.

[0157] The relative timing and/or phase of the MSKC and CC signals can be determined by the processor in algorithm step **1710** (and comparable steps in the other examples provided in the current disclosure) using event-based computations or, alternatively, by evaluating a span of signals in their entirety without identifying specific features within them. For example, an event-based approach using an ECG signal **1904** (equivalently, **22**) for monitoring the user's CC timing **1708** can be configured to identify the specific timing of successive R-waves **24** (CC_t , referring to a timing event within the CC), and an accelerometer signal for monitoring MSKC timing **1706** can target the timing of local peaks or, alternatively, another selected recurrent component of the user's rhythmic musculoskeletal activity ($MSKC_t$). The instantaneous MSKC "phase", i.e., the timing location of the sensed MSKC relative to the CC, can then be computed as

$$MSK\phi = (MSKC_t - CC_{t-1}) / (CC_t - CC_{t-1}),$$

[0158] where the subscripts t and $t-1$ refer to the associated times of the CC and MSKC events and previous event, respectively; and the MSKC event occurs within the considered R-R interval (i.e., $CC_{t-1} \leq MSKC < CC_t$). When $MSK\phi$ is calculated as shown, the resulting phase is presented as a fractional value of the RRI. The same values can be presented in alternative units of measure: multiplying the right hand side by 100 results in units of % RRI; multiplying by 360 provides the phase in degrees; and multiplying by 2π provides the phase in radians. The equivalent relative MSKC-CC timing information $MSK\phi$ determined in **1710** can be computed alternatively using a span of CC **1904** and MSKC **1906** (or **1908**) signals in their entirety rather than by identifying specific CC_t and MSKC event times within the signal. For example, cross correlation methods can be utilized in comparing CC signals (ECG, PPG, etc.) and MSKC signals (accelerometer, load cell, crank location sensor, etc.) to determine the time lag or phase relationship between them in **1710**. In general, numerous computational methods may be used (e.g., in the time-domain, frequency-domain, or other suitable domain) without departing from the scope of the systems described in the current systems.

[0159] In one use example of treadmill system **400** or **500** as shown in FIGS. **4** and **5**, and using control loop **1700** or **1800** as in FIGS. **15** and **16**, according to the current descriptions, consider a runner **408** striding comfortably on a treadmill **404** at a cadence of 165 steps per minute (SPM), with the track speed set nominally to 7.5 miles per hour. This equates to a stride length of 4 feet per step. Consider that the settings of the machine (e.g., incline) have been adjusted so that the user's heart is beating at a closely matched rate, namely at a consistent 165 beats per minute (BPM), and the sensed relative MSKC-CC timing value based on the detection of their foot strikes differs from an exemplary target value **1708** of 40% of the RRI. If the sensed step timing relationship is in the range of approximately $>40\%$ and $<90\%$ of the RRI (i.e., too late), then a slight increase in track speed **1714** can be used to cause the user to step a little sooner if the stride length is maintained, reducing the difference between the sensed and targeted relative step timing **1710/1812**. Conversely, if the sensed stepping is in the range of approximately $<40\%$ and $>90\%$ RRI (too early), then a slight slowing of the track speed **1714** can be used to cause the user to step later and approach the target timing.

[0160] The respective increase or decrease in track speed **1714** could be computed in **1712** to correct the user's **408**

entire step timing difference in one step cycle or over multiple step cycles. In continuing this same example, consider that the user's **408** sensed step timing relative to the target was 50% of the RRI, an error **1710/1812** of $+10\%$ RRI. At 165 SPM (an RRI of approximately 0.364 sec), this indicates that a step error of $\sim +0.036$ sec needs to be eliminated. The treadmill **404** could be sped up in **1714** by 10% for the duration of one step (i.e., 8.25 MPH for -0.36 sec), or at a more subtle speed increase to, for example, 7.6 MPH for several seconds to correct for the user's **408** step timing error more slowly over multiple steps. Alternatively, the treadmill speed may be kept at a higher speed, e.g. 7.55 MPH for an even longer period. Over the longer interims, relative step timing information from subsequent steps and heartbeats becomes available and can be used to more incrementally update the speed and/or incline changes. Small speed changes of these latter magnitudes are generally imperceptible to the user.

[0161] In this example, the correction value **1712** was proportional to the sensed "error" between the sensed and the target relative timing **1710/1812**. The size of the adjustment, e.g., made over one or multiple steps, is defined by a scaling factor, or "gain", used to define the magnitude of the correction **1712** each time it is implemented. Options for a more sophisticated control loop can compute the magnitude of the correction by further including terms related to the time integral of the error **1710/1812**, and further optionally with terms related to the error's **1710/1812** time-rate-of-change (derivative). Such P-I-D (proportional-integral-derivative) control loops are well known in control systems, as are methods for tuning the proper balance of their respective gain factors (K_p , K_i , K_d) to create a responsive yet stable system. One or more of the K-factors can be zero.

[0162] Limits on the range of acceptable speeds and accelerations resulting from the adjustments made in **1712** can be included, important from both a user comfort and a safety perspective. Furthermore, control **1714** may optionally be effectively suspended if the sensed relative timing is within a predefined acceptable tolerance of the target **1708** and/or, in another example, if the user's HR and MSKC cadence differ by more than a predefined amount.

[0163] While the treadmill track speed was adjusted to change step timing in this example, the incline could alternatively be varied to achieve the same goal, with the change in incline based on a suitably configured control loop. For example, the change in track speed described above to correct the user's relative step timing error **1710/1812** would be replaced by a change **1714** in incline, affecting the user's stride length and step timing to reduce and ultimately correct the sensed error value. In another alternative, both track speed and incline can be adjusted in **1714** based on the current and recent values of the sensed relative MSKC-CC timing, with changes in both directed to affecting the user's step timing to reduce the sensed error **1710/1812**.

[0164] In yet another embodiment, adjustments in the treadmill **404** track speed **1714** (such as those described above) may be accompanied by a simultaneous change in incline in an amount selected to keep work output substantially constant and thereby mitigate likely HR changes. For example, a decrease in track speed used to affect the user's step timing may be accompanied with a paired increase in incline, and visa versa, so as to help maintain a more stable HR. As an example, if the track speed is changed from 7.5 to 7.6 MPH to correct a sensed relative MSKC-CC timing

error, the user's work output increases; slightly lowering the incline, e.g. from 2% to 1.8%, reduces the required work and will help maintain the user's work output and HR.

[0165] All of the examples described above were based on the use of a treadmill, however the same principles apply with other exercise equipment.

[0166] FIG. 18 illustrates control system 1000, another embodiment of the present disclosure in which an "outer" control loop 1004 is added to an "inner" control loop 1006. The inner loop 1006 operates as described above in relation to system 1700 of FIG. 15, though system 1800 of FIG. 16 could also be used in this context. The outer loop 1004 makes further adjustments to the exercise equipment so as to attain and/or maintain the user's HR near a target HR 1008. The response time of the outer "HR" control loop 1004 is generally configured to be slower than the inner "phase" control loop 1006, so as to reduce the likelihood of the two loops interfering with each other, as well as the fact that the user's average HR typically responds more slowly than can the timing of their MSKC and its cadence.

[0167] Variations of the control loops depicted by FIGS. 15, 16 and FIG. 18 can be used without disrupting the basic functionality of the system. For example, the looping can occur after the process step that computes the error term(s) 1710 and 1812, with the one or more correction values computed and implemented in parallel to, but outside of, the looping process. Furthermore, while HR is targeted in the outer loop 1004 of FIG. 18, other physiologic variables can be selected, or, in an alternative embodiment, adding further loops can be used to control multiple physiologic variables.

[0168] As an alternative to making adjustments to the overall track speed of a treadmill to affect the user's step timing, more sophisticated changes to the tracking can be used. For example, while the nominal speed may be generally maintained at, for example, 7.5 MPH as in the example scenario described above, the track speed can be changed non-uniformly, transiently, and timed to occur when the user's foot strikes the track—either speeding up or slowing while the foot is in contact with the track. This "kick" or "drag" can have an effect of changing the user's cadence just slightly and in the proper direction, to have the desired effect in correcting the sensed timing error. In another example considering a rowing apparatus, the drag on the oar can initially be made to be higher or lower than under nominal conditions so as to impact the timing of the executed stroke. While the treadmill track speed and rowing resistance were used in these examples, the same principal can be used with other exercise equipment. In each case, the change to the exercise equipment setting or induced behavior is intended to cause a relatively small change in the user's MSKC timing to correct the sensed relative timing error with respect to the target, without greatly impacting the frequency and stroke of their activity (e.g., step rate and stride length while running, or stroke rate and length while rowing).

[0169] In an example exercise routine, prior to enabling the active control of the equipment, a user may warm-up until their HR approaches his or her natural cadence region. Several commercially available aerobic fitness machines incorporate standard approaches for assisting the user in achieving and maintaining a HR value within a target HR zone—such as by adjusting the incline on a treadmill. The systems described in FIGS. 15-16 and by the inner loop 1004 of FIG. 18 are intended to operate when the user's MSKC repetition rate (cadence) and CC rate (HR) are

similar, or alternatively have an approximately unitary fractional relationship (i.e., 1:2, 1:3, etc.).

[0170] When the sensed difference between their HR and this natural cadence (or integer multiple of the cadence) becomes sufficiently small in a predefined range, the system may optionally provide feedback prompts (audible, visual, tactile . . .) to assist the user in finding an MSKC timing for their activity to be in proper coordination with their CC timing. If used, these prompts can then be discontinued once a period of time has elapsed or other defined condition is met (e.g., stable and small measured absolute phase-error). Once the user attains a sufficiently matched HR and MSKC cadence as described, the system's "fine-tuning" control of the equipment settings is enabled and the subsequent measured relative timing error values are used in a control loop (such as those shown in FIGS. 8-9) to make changes to the apparatus in an ongoing manner and/or as needed so as to maintain a proper MSKC-CC timing relationship.

[0171] If the systems described here sense that the user's HR exceeds the target HR 1008 by more than a predefined amount, the operation of the control loop(s) (e.g., inner loop 1006 and outer loop 1004 in FIG. 18) may be discontinued, and, in an example, the exercise equipment settings made to revert to a set of "safe" conditions (e.g., lower fixed speed and resistance) or, in another example, machine control made to revert to a more conventional approach already available in the equipment.

[0172] Alternative configurations of the systems described above may target a controlling measure other than the relative CC-MSKC timing. In one example, the targeted relationship may include a nonzero difference between the user's average HR and average MSKC cadence (e.g., target cadence=HR+2), with the control loop adjusting the equipment setting so as to generally maintain a cadence that differs from the user's HR by a targeted value. As the user's HR changes, the targeted MSKC cadence also changes, and the system makes adjustments to the exercise equipment accordingly. In such a configuration, the user's resulting relative MSKC-CC timing cycles through the full 0-100% RRI span at a rate similar to difference between their HR and cadence.

[0173] In configurations where the target condition represents a specified relative MSKC-CC timing value, the target value need not be a single defined value used throughout an exercise period. For example, a particular activity may involve setting the target value to 45% RRI for certain period of time, e.g., 10 minutes, and then change to 65% RRI for the another period of time. Activity profiles may be defined according to a "script" of two or more settings comprising target values and durations, or a single setting used for the entire duration of the activity.

[0174] Depending on the activity involved, the type and design of equipment and the type and location of the signal transducer used as noted above, the sensed timing values may not represent the onset of skeletal muscle contraction as shown by 35 in FIG. 4C, instead corresponding to a different portion of the MSK pump cycle. In a representative example, a sensor on a bicycle used for determining the timing of the rider's pedaling may identify when the crankshaft passes the seat tube in one implementation, or the down-tube in another implementation; consequently, the same relative MSKC-CC pump timing relationship is identified by two different sensed relative MSKC-CC event times. In cases in which the sensed MSKC event corre-

sponds to a different portion of MSKC than is shown in sequence **36** or **37**, the targeted relationship value should be adjusted accordingly or, alternatively, the MSKC times transformed to better associate with the general onset of maximal skeletal muscle contractions. In yet another alternative usage, the user's physiologic response to the sensed relative MSKC and CC timing signals is characterized empirically (calibrated), as described further below.

[0175] Similarly, the CC timing may depend on the type of signal transducer used and where on the body the signals are derived. For example, the readily-identified R-waves **24** of an ECG signal represent the electrical activity of the heart and occur earlier than the peak systolic arterial pressure seen in waveform **32** of FIG. **4A**. A PPG signal obtained peripherally will be delayed further, as it takes time for the pressure wave to propagate. There may be additional delays between the physiologic CC and MSKC events and when the system determines they occurred due to signal conditioning, transmission, and signal processing/filtering methods used.

[0176] Beyond these signal transducing and equipment influences to the sensed timings, the timing relationship of the actual onset of maximal MSK blood pumping from muscle contractions **34** with respect to the CC may depend on the nature of the activity and exercise equipment used. For example, the user's MSK blood-pumping characteristics resulting while running on a treadmill may differ from rowing or bicycling because of the different muscle groups involved, differing inertial effects, and/or other factors. In addition, MSK blood pumping can come in series or in parallel from multiple parts of the body, depending again on the nature of the activity and exercise equipment. For example, during bicycling, a user may push down with one leg, pull up with the other leg, and pull on the handlebars with one or both arms, each with similar or different MSKC timing relative to the CC timing.

[0177] The targeted relative timing relationship value **1708** (or target timing within the RR interval) shown in FIGS. **15-16** can be selected based on the general population response for a particular type of activity and/or exercise equipment, or determined empirically to optimize one or more selected physiologic parameters of the user during their use of the exercise equipment. Determining an optimal or preferred timing relationship can be quite useful to help accommodate variations from all of the timing influences noted above, as the overall system—including the user's physiology and activity—is considered as a whole.

[0178] Such empirical "calibration" includes exposing the user to a variety of relative MSKC-CC timing relationships during their activity to find the values associated with a general physiologic economy, such as a reduced heart rate while moving at a generally fixed speed and resistance (work output). In an exemplary calibration mode, the system varies the targeted relative MSKC-CC timing relationship (e.g., as shown in FIG. **15** or **16**) over time to expose the user to a number (at least two) of different relative timings at an otherwise stable work output level, and then identifies the "optimum" relative timing based on their measured physiologic responses (which includes any activity-dependent and equipment-dependent factors described above). Example physiologic measures include, but are not limited to the user's: HR, systolic and/or diastolic blood pressure, cardiac output, cardiac perfusion, muscle perfusion, muscle pH, cerebral perfusion, EEG activity, respiratory gases (e.g., —VO₂, VCO₂, RER), and lactate levels. In each case, the

optimum relative MSKC-CC timing relates to a desired condition, generally associated with a relatively improved physiologic economy, as reflected by an appropriate minimum or maximum of the respective measure of interest.

[0179] In more sophisticated systems, more than one MSKC sensor can be used simultaneously for sensing the timing of different muscle groups involved during the exercise activity, along with their timing relationship to one another and to the CC. These multiple signals and sensed timing events offer more information about the user's overall MSK blood pumping and can be used by the system to adjust multiple components of the exercise equipment to "fine tune" the timing of the user's various muscle groups.

[0180] In alternative embodiments comprising the concepts presented here, the equipment settings are adjusted by the system only if the user's relative CC-MSKC timing is sensed to occur generally and/or persistently at an unfavorable value, such as one associated with iMCP. In another example, this behavior operates in parallel with other control mechanisms of the exercise equipment that are being used, such as any one of methods described above, but takes over control if the user's relative timing is sensed to be unfavorable beyond a predefined value (e.g., generally exhibiting an unfavorable relative timing relationship for a duration that exceeds a pre-defined limit). Such background monitoring and intervention configurations may be considered as "watchdog modes," only making needed adjustments to the exercise equipment when certain undesirable behaviors are detected. Examples of adjustments to the exercise equipment include increases or decreases in: the track speed and/or incline of a treadmill; the gearing or, equivalently, resistance of a bicycle; the resistance and/or allowed stroke length of a rowing machine; or any setting of the equipment that results in a change in MSKC event and/or CC timing that does not maintain the existing sensed relative timing relationship.

[0181] In another example embodiment, the user exercises at a comfortable MSKC cadence; the system senses their HR and then makes adjustments to the equipment to cause their HR to approach the sensed value of their MSKC cadence. This allows the user's natural tendencies to optimally align their respective CC and MSKC timing (cardio-locomotor synchronization). As an example of this embodiment, the system sets the treadmill to a track speed that results in the user stepping at or close to 160 steps/min, a value that may be pre-set by the user. Alternatively, the user can adjust the track speed to find a natural and/or comfortable cadence; in yet another alternative, one that paces the user at a tempo of music they like to exercise to.

[0182] FIG. **19** illustrates an example control loop **1100** used by system **200** to adjust the incline to a value that causes the user's heart rate to settle near their sensed MSKC rate, in the first case near 160 beats/min, or in the alternative example—at the sensed rate the user found to be their desired cadence. The user's sensed CC **1104** and MSKC **1106** timings are used in **1108** to determine the MSKC cadence (step rate), HR, and the cadence-HR difference. If the sensed HR differs from this sensed step rate, process step **1110** computes a correction value to the incline, up or down accordingly, so as to reduce this difference. The system then implements this correction value on the exercise equipment in **1112** and the control loop repeats. Increasing the incline causes the user's HR to increase as their workload is increased, and conversely decreasing incline reduces work-

load and HR. Optionally, if the user's natural relative MSKC-CC timing as sensed by the system differs from a targeted value **1708** by a predefined amount and/or duration, the exercise equipment may then be further adjusted automatically to reduce the relative timing error according to the embodiments described above.

[0183] In yet another example embodiment, the user may select to control a portion of the available settings of the exercise apparatus manually, while allowing the remaining portion to be controlled by any of the systems described above for maintaining their relative MSKC and CC cycle timing. For example, the user may choose to manually control one or more of the speed, work output, cadence, resistance, stride length, incline, or other available settings of the exercise equipment, selecting a level or range according to their preference, while the remaining adjustable behaviors are controlled by the automated algorithms in response to the sensed MSKC and CC signals.

[0184] In further embodiments, audible prompting can be provided to assist the user in maintaining a target cadence. For example, a song's beat, or a metronome set at a substantially fixed prompt rate, can be provided at a target rhythm, with the exercise machine's adjustments used by the system to automatically bring the user's sensed HR to the substantially fixed prompt rate. Optionally, the exercise equipment may then be further adjusted by the system to coordinate the user's MSKC and CC cycle timing according to the embodiments described above.

[0185] Applicable to each of the example embodiments described, and as noted in some of the examples, the system can be designed to identify when the user's HR and activity cadence differ by close to an integer multiple (i.e., MSKC:CC=1:N, where N=1, 2, 3, . . .). Under these conditions, the system can make proper adjustments to the exercise equipment to control the user's MSKC timing with respect to their CC cycle while maintaining an MSKC cadence that corresponds to the same multiple. For example, foot strikes during walking can occur every other heart beat (targeted timing **37** in FIG. 1), as can strokes during rowing every 2 (or another multiple number) heartbeats.

[0186] In embodiments of the method and systems, during instances when MCP is not adequately achieved using automated real-time adjustments in the exercise equipment's settings, the user can be additionally or alternatively provided with an auditory, visual or tactile prompt to alter their MSKC. For example, a user may be prompted to move with rhythmic timing directed by an audible prompt. Alternatively, a user may be directed to increase or decrease stride length in response to instruction or prompting. In alternative embodiments, these prompts may be provided in the context of a game interface. Calibration Methods

[0187] FIG. 20 illustrates a flow chart for determining a target MSKC to CC timing relationship empirically, i.e., "calibrating" a system, in accordance with an embodiment. As shown in FIG. 20, a method for determining a target MSKC to CC timing relationship of a preferred embodiment includes detecting a first characteristic of a signal responsive to a CC timing of a user that repeats at a frequency that corresponds to the HR of the user using a sensor **S1000**; detecting a second characteristic of a signal responsive to a rhythmic MSK activity timing of the user that repeats at a frequency that corresponds to the MSKR of the user using a sensor **S1010**; determining a value representative of an actual timing relationship between the first characteristic and

the second characteristic **S1020**; detecting a third characteristic of a signal using a sensor corresponding to a physiological metric that varies with the actual timing relationship **S1030**; and determining the target value representative of a preferred timing relationship between the first and second characteristics by identifying the value representative of the actual timing relationship that corresponds with a preferred value of the variable physiological metric **S1040**.

[0188] The method functions to calibrate or recalibrate the system empirically so that the system may be tailored to each user, activity, device configuration, and/or time. For example, the relationship between MSKC timing and CC timing that leads to a preferred value of a physiologic variable may vary among users engaged in a similar physical activity, between different activities for one user, and/or between different instances of the same activity over time. Additionally, the specific system configuration can affect the measured relative timing. For example, use of the ECG T-wave vs. the R-wave vs. the peak systolic amplitude of a PPG signal as a timing indication impacts the measured CC timing, as does the location of the PPG sensor. Additionally, the location of a crank sensor placed on a bicycle and the location of the MSKC sensor incorporated within a treadmill system impacts the values and timing of the signals used to measure MSKC timing independent of the underlying timing of the CC and MSKC blood pumps. Thus, the method as shown in FIG. 20 functions to calibrate or recalibrate the system empirically to correct for or plan for any of the factors that can affect the measured MSKC to CC timing relationship and its relationship to a target physiological condition (e.g., MCP) or a preferred value of a physiologic variable (e.g., a reduced HR).

[0189] In some embodiments, a system may be configured to determine the optimal relative MSKC to CC timing of a user once. Alternatively, the system may temporarily switch back to a "calibration mode" periodically to ensure ongoing optimization of timing. In both cases, in an example embodiment, a HR of a user while exercising at a given work load may correlate with the timing of the MSKC relative to that of the CC, with relatively lower HR values at a given work load associated with improved overall blood pump hemodynamics. By exposing the user to a variety of relative MSKC to CC timing values over a period of time, and then identifying the relative timing value, characteristic, or relative value relationship associated with the lowest HR, the system may be used to identify the "favorable" or "optimal" timing relationship and/or hemodynamic sensor signal characteristics for the specific user, activity, and system configuration in use during the calibration process. This empirically determined value, signal characteristic, or relative value relationship may then be used subsequently to represent the target MSKC to CC timing relationship. Optimal timing relationships may also be derived from additional or alternative measures other than HR.

[0190] As shown in FIG. 20, step **S1000** includes detecting, using a sensor, a first characteristic of a signal responsive to a CC timing of a user that repeats at a frequency that corresponds to the HR of the user. Step **S1000** may, in example embodiments, function to identify a recurrent aspect of a CC of the user, as described above. In some embodiments, the first characteristic may be one aspect of a signal, for example from ECG or PPG, such that other aspects may be used to define other characteristics, for example an MSKR.

[0191] As shown in FIG. 20, step S1010 includes detecting a second characteristic of a signal responsive to rhythmic MSKC timing of the user that repeats at a frequency that corresponds to the MSKR of the user using a sensor. Step S1010 may, in example embodiments, function to determine a recurrent aspect of an MSKC of a user, as described above. In some embodiments, the sensor in S1000 and S1010 may be the same sensor, for example a PPG sensor. Alternatively, the sensors in S1000 and S1010 may include distinct sensors, for example an ECG and an accelerometer or a PPG and an accelerometer. In some embodiments, the first characteristic and the second characteristic are the same aspect of a first signal from a first sensor. Alternatively, the first characteristic and the second characteristic may be different aspects of a first signal from the first sensor. For example, one or more features of a PPG signal may be used to determine a CC and MSKC timing or timing relationship of a user, as described above in accordance with FIGS. 6 and 7. In some embodiments, the first characteristic and second characteristic may be derived from independent first and second signals from first and second sensors, respectively.

[0192] As shown in FIG. 20, step S1020 includes determining a value representative of an actual timing relationship between the first characteristic and the second characteristic. Step S1020 may function to determine a timing relationship between a CC and MSKC of a user using the observed individual timings of the first and second characteristics of steps S1000 and S1010, respectively. In alternative embodiments, the actual timing relationship may be determined by using a cross correlation between the first characteristic and the second characteristic.

[0193] As shown in FIG. 20, step S1030 includes detecting a third characteristic using a sensor corresponding to a physiological metric that varies with the actual timing relationship. Step S1030 preferably functions to further measure a third physiological parameter of a user as compared to the first and second characteristics. Example physiologic metrics include, but are not limited to the user's HR, systolic and/or diastolic blood pressure, cardiac output, cardiac perfusion, muscle perfusion, muscle pH, cerebral perfusion, EEG activity, respiratory gases (e.g., VO₂, VCO₂, RER), tissue or blood glucose and lactate levels, and blood insulin levels. In each case, the corresponding preferred value of the metric reflects a desired condition, generally associated with a relatively improved physiologic economy, typically an appropriate minimum or maximum of the respective measure of interest.

[0194] Further, the sensors in S1000, S1010, and S1030 may be the same sensor in certain embodiments, or can use two or more different sensors in other embodiments, for example S1000 may be an ECG, while S1010 may be an accelerometer, while S1030 may be a metabolic measurement system for calculating oxygen consumption, CO₂ production, respiratory volumes, and other related measurements. In an alternative embodiment, the sensor of S1010, S1010, and S1030 can all represent one or more PPG sensors.

[0195] In some embodiments, the system may guide the user towards a target or preferred value of a physiological metric, such that the physiological metric is at a beneficial or advantageous level to the user. Additionally, the third characteristic may be used to determine when a user achieves MCP or a target MSKC to CC timing relationship. In some embodiments, the first characteristic and the third

characteristic may be the same aspect of a first signal from a first or third sensor. Alternatively, the first characteristic and the third characteristic may be different aspects of a first signal from the first or third sensor. Alternatively, the first, second, and third characteristics may be three distinct aspects of a first signal from the first sensor. In some embodiments, the first, second or third characteristics may include a Fourier transform.

[0196] As shown in FIG. 20, step S1040 includes determining the target value representative of a preferred timing relationship between the first and second characteristics by identifying the value representative of the actual timing relationship between the first and second characteristics that corresponds with a preferred value of the variable physiological metric. An exemplary "value" may, for example, include a specific or relative characteristic or set of characteristics of the signal or signals described in FIG. 20. Step S1040 may function to identify a value of the MSKC to CC timing relationship that causes the physiological metric to exhibit a generally more favorable or preferred value, using that identified value subsequently as representative of the target timing relationship. For example, a preferred value of a physiological metric may be a lowest average HR of the user observed under otherwise constant conditions, because the hemodynamics that result from MCP can lead to an average lowest HR for the user. The value representative of the target MSKC to CC timing relationship (i.e. the value representative of the preferred timing relationship between the first and second characteristics) might alternatively include, for example, values described by a sensed PPG signal that correlate with a particular "PPG shape", "PPG characteristic" or "PPG relative shape" without knowing exactly the timing relationship represented by that shape.

[0197] In one exemplary process that utilizes the method outlined in FIG. 20 for determining a target timing relationship, a user is provided timing prompts for performing a rhythmic activity at a generally stable work output level using, for example a treadmill such as shown in FIG. 10 and the prompting system shown in FIG. 3A. The system is configured to vary the targeted MSKC to CC timing relationship over time to expose the user to a number (at least two) of different timing relationships, and then identifies the "optimum" timing relationship that corresponds to a relatively favorable value in the measured physiologic metric. This optimum timing relationship may then be considered the "calibrated" target timing relationship for subsequent use. In an alternative embodiment, this procedure may be used to identify a measured characteristic of a signal responsive to the actual MSKC to CC timing relationship that corresponds to the relatively favorable value in the measured physiologic metric. In one example, the signal may be a PPG and the measured characteristic may be the pulse amplitude or, additionally or alternatively, a measure of the signal complexity.

[0198] In some embodiments, the method of FIG. 20 may further include providing to the user a recurrent prompt from a prompt device at a prompt rate as a timing indication for performance of the rhythmic musculoskeletal activity, such that the user's MSKC timing in response to the prompt substantially correlates with a preferred value of the physiological metric.

[0199] In some embodiments, the calibration method of FIG. 20 may be used to determine a target value representative of a preferred MSKC to CC relative timing relation-

ship through analysis for trends in sensed MSKC to CC timing signals that occur when a user is guided by an exemplary system to readily achieve cardiocomotor synchronization, thereby determining signal characteristics that correlate with a naturally preferred MSKC to CC relative timing relationship.

[0200] Natural cardiocomotor synchronization may be described as “physiological MSKC to CC timing stickiness”—wherein a particular MSKC to CC timing relationship naturally preferentially occurs with the highest frequency of all possible timing relationships, due to a natural physiological tendency for many individuals towards a pump timing consistent with MCP. Physiological MSKC to CC timing stickiness may occur when the HR of the user approaches an integer multiple of the MSKR of a user. Therefore, in embodiments of the system and methods, a user is paced at a MSKR while being guided to a level of exertion at which the HR of the user approximates an integer multiple of the MSKR of the user. With the HR and MSKR substantially aligned in this manner, values representative of the MSKC to CC timing relationship are monitored and analyzed on a processor in order to identify statistically more common values representative of specific CC timing to MSKC timing that may be preferred, due to the natural tendency for physiology to trend towards a higher incidence of the physiologically more beneficial (preferred) timing relationships (e.g. timing that is consistent with MCP) and to trend away from timing relationships that are not physiologically preferable (e.g. timing that is consistent with iMCP). In another example, the system may be calibrated by monitoring the frequency of MSKC to CC timing relationships during periods of physical activity wherein the HR approaches an integer multiple of the MSKC without the user being guided. For example, certain individuals are able to naturally step with the timing of maximal MSKC arterial pumping occurring during early cardiac diastole while running and/or walking without being prompted to do so, at least for statistically significant albeit often short periods of time. In preferred embodiments of a calibration method, this stickiness is facilitated when users are provided with an MSKC timing indicator (e.g. a metronome or musical step timing prompt while running) that is constant while they are guided, to a target HR where the target HR is substantially an integer multiple of the MSKR.

[0201] In another example method for determining “stickiness”, prompting a user at a rate that is slightly different than an integer multiple of the HR may be used. For example guiding the user to an MSKR (MSKCs per minute) equal to their current HR plus 1, 1.5, 2, 3, 4 or minus 1, 1.5, 2, 3, 4 per minute, may increase the likelihood of seeing the stickiness phenomenon occur over and over as the user sequentially cycles through various MSKC to CC timing relationships. The MSKC to CC timing relationship stickiness, which may be caused by a naturally occurring neural feedback loop within the cardiac tissue, typically includes a natural physiological delay that may be compensated for on a processor in calibration embodiments of the method and system. In some calibration embodiments, the system may oscillate or alter MSKC prompt timing in relationship to the user’s CC timing so that the prompt guides the user back and forth across a desired MSKC to CC phase range, while the system analyzes the values of the signals for trends consistent with this physiological stickiness phenomenon. Further, the system or user may loosen the “control” in a target

MSKC to CC timing relationship range in order to promote physiological stickiness. For example, automatic controls may automatically adjust an incline, speed, cadence, phase, or target HR, to bring the MSKR and HR of the user into adequate alignment to facilitate determination of the values of the sensed signals that represent the most frequent MSKC to CC relative timing of a physiological timing stickiness of the user.

[0202] Some embodiments of the system calibrate the system through identification of physiological MSKC to CC timing stickiness, while in other embodiments, one or more of the described techniques of enabling physiological stickiness may be used as a technique for guiding a user to achieve MCP. In exemplary calibration and MCP guidance embodiments, the user’s work output is guided or otherwise directed towards a target HR, such that the target HR of the user equals an integer multiple of the MSKR of the user. The MSKR (cadence) of the user may be an unguided (e.g. naturally occurring) cadence, or the user may be guided by an embodiment of the system to a designated substantially constant cadence, in either case, tied to a target HR chosen by the user or suggested by the system. In some embodiments, the work output may be modified to approach the target HR. For example, the work output may be modified by guiding the user to changes in stride length or incline during walking or running, or by altering resistance of a bicycle or aerobic exercise machine. Further, the MSK cadence may be determined by the target HR. Alternatively, the target HR may be determined by the desired cadence. In some embodiments, a combination of both desired target HR and desired cadence may be used to select an intermediate cadence and target HR.

[0203] In another embodiment of a calibration process, the user is provided with a prompt that guides the user to an MSKR that slightly differs by a constant amount from the user’s HR (e.g., +1 or +1.5 or +2 or . . . per minute) so that the user’s MSKC to CC timing relationship cycles, such as is seen in FIG. 6A. During this period of time (e.g., 1 to 5 minutes), the actual timing relationship S1020 and associated values of the physiologic metric S1030 are recorded. The target timing relationship is then determined according to S1040. In yet another embodiment, this process is repeated after altering the prompt to guide the user to an MSKR with an opposite constant difference to their HR (e.g., -1 or -1.5 or -2 or . . . per minute, or vice versa if the former guidance was to be slower). The final target timing relationship is then determined using the two results obtained in S1040 under the two conditions, for example the average of the two obtained target values, thus helping to compensate for time lag between the observation of the preferred value of the physiologic metric and the user’s actual MSKC to CC timing relationship that enabled it.

[0204] In some embodiments, a user may prefer to be alerted when a HR and cadence (MSKR) of the user are nearly aligned, such that the user may turn on and readily engage in an MCP enabling guidance. This functionality could also be turned on automatically when MSKR is very close to an integer multiple of the HR of a user. Thus, the user may “step to the beat” or “move to the beat” only when the user’s cadence and HR are already nearly aligned. In an exemplary embodiment, a PPG sensor and an accelerometer can both exist in an earbud embodiment of the invention. In this exemplary embodiment, the user could be walking down the street without thinking about stepping to the beat,

when the device identifies that the HR and step rate are substantially equivalent, therefore notifies the user that stepping to the beat to achieve MCP functionality is easily available. The user may then “opt in” at any time, turning on guidance, for example music. In this example, the music may be selected from the user’s music files for its beat frequency but the beat frequency and timing may be modified, as needed, so that the beat of the music provides a timing indication that guides the user to MCP, according to the methods described above.

[0205] Embodiments described, and hence the scope of the descriptions of systems and methods below, encompass embodiments in hardware, software, firmware, or a combination thereof. It will also be appreciated that the methods, in the form of instructions having a sequence, syntax, and content, of the present disclosure may be stored on (or equivalently, in) any of a wide variety of computer-readable media such as magnetic media, optical media, magneto-optical media, electronic media (e.g., solid state ROM or RAM), etc., the form of which media not limiting the scope of the present disclosure. A computer reading said media is operable to either transfer (e.g., download) said instructions thereto and then operate on those instructions, or cause said instructions to be read from the media and operate in response thereto. Furthermore, devices (e.g., a reader) for accessing the instructions on said media may be contained within or connected directly to the computer on which those instructions operate, or may be connected via a network or other communication pathway to said computer.

[0206] Furthermore, while a plurality of exemplary embodiments has been presented in the foregoing detailed description, it should be understood that a vast number of variations exist, and these exemplary embodiments are merely representative examples, and are not intended to limit the scope, applicability or configuration of the disclosure in any way. Various of the above-disclosed and other features and functions, or alternative thereof, may be desirably combined into many other different systems or applications. Various presently unforeseen or unanticipated alternatives, modifications variations, or improvements therein or thereon may be subsequently made by those skilled in the art which are also intended to be encompassed by the present disclosure.

[0207] In addition, the methods and systems described herein guide the user in the performance of two major categories of rhythmic physical activities, namely MSK movement and skeletal muscle contraction cycles, in order to favorably coordinate peripheral vascular pumping with the heart’s pumping activity. These two categories of rhythmic physical activities, together or individually, are included in the scope of the disclosure, even where only one of the two categories has been described. Therefore, for example, the descriptive phrases MSK movement, skeletal muscle contraction, skeletal muscle relaxation, MSK pumping cycles, and MSK activity should in many cases be considered included where one or more of the terms was not mentioned.

[0208] Therefore, the foregoing description provides those of ordinary skill in the art with a convenient guide for implementation of the disclosure, and contemplates that various changes in the functions and arrangements of the described embodiments may be made without departing from the spirit and scope of the disclosure.

What is claimed is:

1. A method for achieving a favorable relative timing relationship between a rhythmic musculoskeletal activity cycle (MSKC) of a user and a cardiac cycle (CC) of the user, the method comprising:

recurrently providing an output comprising a movement guidance from a prompt device to the user for guiding performance of a rhythmic musculoskeletal activity; and repetitively:

detecting a signal that correlates to a cyclically-varying arterial blood volume in a tissue of the user;

determining, with a processor, a measured characteristic of the signal, which varies with adjustments to the timing relationship between the MSKC and the CC of the user, wherein the measured characteristic comprises at least one of: a measure of peak amplitude, a measure of average amplitude, a measure of peak to valley height, a measure of waveform complexity, and a modulation amplitude;

measuring, with the processor, an instantaneous behavior of the measured characteristic;

comparing, with the processor, the instantaneous behavior to a recent historical behavior of the measured characteristic over a given rolling window of time during performance of the rhythmic musculoskeletal activity; and

when the measured characteristic displays a trend relative to a local instantaneous or average maximum of the measured characteristic, automatically adjusting, with the processor, the movement guidance to move the user towards the local instantaneous or average maximum of the measured characteristic in order to achieve a hemodynamically more favorable timing relationship between the MSKC and the CC of the user.

2. The method of claim 1, wherein the movement guidance includes at least one of a recurrent audible, visual, or tactile prompt.

3. The method of claim 1, wherein detecting the signal comprises using as the sensor technology one of photoplethysmography, impedance plethysmography, laser-Doppler blood flow, acoustic sensing, and arterial tonometry.

4. The method of claim 2, wherein a heart rate of the user is substantially an integer multiple of a rate of the prompt.

5. The method of claim 1, further comprising:

detecting, using one or more sensors, one or more signals that correlate to a heart rate of the user and a musculoskeletal activity cycle rate (MSKR) of the user;

determining, using the processor, the heart rate of the user and the MSKR of the user by processing the one or more signals;

specifying a maximum allowable absolute difference between the heart rate and the MSKR; and

executing, using the processor, steps of claim 1 only when an absolute value of a difference between the MSKR and heart rate is less than, or less than or equal to, a specified allowable difference.

6. The method of claim 5, further comprising:

specifying a target MSKR; and

recurrently providing the output from the prompt device when the absolute value of the difference between the MSKR and the target MSKR is greater, or greater than or equal to, the specified allowable difference, the output repeating at a prompt rate.

7. The method of claim 6, wherein the target MSKR is an integer multiple of the prompt rate.

8. The method of claim 1, wherein the movement guidance includes instructing the user in at least one of an MSK activity timing and an MSK activity effort.

9. The method of claim 8, wherein instructing the user in the MSK activity effort includes providing movement guidance on stride length during running or walking, gear use while riding a bicycle, resistance, MSKC movement distance or incline while using exercise equipment, or stroke length during rowing or swimming.

10. The method of claim 8, wherein instructing the user in the MSK activity timing includes providing a MSKC prompt at a prompt rate to guide the user to an MSKR that is an integer multiple of the prompt rate.

11. The method of claim 1, further comprising a calibration process, said calibration process comprising:

detecting a second characteristic of at least one of the signal and one or more additional signals corresponding to a physiological metric that varies with the timing relationship between the MSKC and the CC of the user, using the sensor or one or more additional sensors; and determining the relative maximum value of the measured characteristic as a relative value of the trend that corresponds with a preferred value of the physiological metric.

12. The method of claim 11, wherein the physiological metric comprises a measure of at least one of: a heart rate, a minute ventilation, a blood pressure, a blood flow, a cardiac output, an electrical brain activity, an oxygen consumption, a tissue pH, a tissue lactic acid level, or a CO₂ production.

13. A system for achieving a favorable relative timing relationship between a rhythmic musculoskeletal activity cycle (MSKC) of a user and a cardiac cycle (CC) of the user, the system comprising:

a prompt device configured to provide recurrently an output comprising a movement guidance to the user for guiding performance of a rhythmic musculoskeletal activity;

a sensor configured to detect a signal that correlates to a cyclically-varying arterial blood volume in a tissue of the user; and

a processor, coupled to the prompt device and the sensor, wherein the processor is configured to:

determine a measured characteristic of the signal, which varies with adjustments to the timing relationship between the MSKC and the CC of the user, wherein the measured characteristic comprises at least one of: a measure of peak amplitude, a measure of average amplitude, a measure of peak to valley height, a measure of waveform complexity, and a modulation amplitude,

measure, with the processor, an instantaneous behavior of the measured characteristic,

compare, with the processor, the instantaneous behavior to a recent historical behavior of the measured characteristic over a given rolling window of time during performance of the rhythmic musculoskeletal activity, and

when the measured characteristic displays a trend relative to a local instantaneous or average maximum of the measured characteristic, automatically adjust, with the processor, the movement guidance to move

the user towards the local instantaneous or average maximum of the measured characteristic in order to achieve a hemodynamically more favorable timing relationship between the MSKC and the CC of the user.

14. The system of claim 13, wherein the sensor technology includes one of photoplethysmography, impedance plethysmography, laser-Doppler blood flow, acoustic sensing, and arterial tonometry.

15. A method for achieving a favorable relative timing relationship between a rhythmic musculoskeletal activity cycle (MSKC) of a user and a cardiac cycle (CC) of the user, the method comprising:

repetitively:

detecting a signal responsive to cyclically-varying arterial blood volume in a tissue of the user using a sensor;

determining, with a processor, a first measured characteristic of the signal that repeats at a heart rate (HR) of the user and determining the HR of the user from the first measured characteristic;

recurrently providing an output comprising a guidance prompt from a prompt device to the user as a timing indication for performance of a rhythmic musculoskeletal activity, wherein the guidance prompt is timed such that the HR is an integer multiple of a rate of the guidance prompt;

determining, with a processor, a second measured characteristic of the signal, which varies with an actual MSKC to CC timing relationship of the user, wherein the second measured characteristic comprises at least one of: a measure of peak amplitude, a measure of average amplitude, a measure of peak to valley height, a measure of waveform complexity, and a modulation amplitude;

measuring, with the processor, an instantaneous behavior of the second measured characteristic;

comparing, with the processor, the instantaneous behavior to a recent historical behavior of the second measured characteristic over a given rolling window of time during performance of the rhythmic musculoskeletal activity; and

when the second measured characteristic displays a trend relative to a local instantaneous or average maximum of the second measured characteristic, automatically adjusting, with the processor, the guidance prompt to move the user towards the local instantaneous or average maximum of the second measured characteristic in order to achieve a hemodynamically more favorable MSKC to CC timing relationship.

16. The method of claim 1, wherein the measure of waveform complexity is at least one of: a measure of waveform smoothness and a measure of a degree to which the waveform is sinusoidal.

17. The method of claim 1, wherein the instantaneous behavior is one of: an increasing modulation amplitude, an increasing peak amplitude, an increasing average amplitude, a decreasing waveform complexity, and a change in timing of an aspect of the signal that repeats at a heart rate of the user.

18. The method of claim 15, further comprising detecting the MSKC of the user using the sensor or a second sensor.

19. The method of claim **18**, wherein the second sensor is one of: an accelerometer, an electromyographic sensor, a pressure sensor, a switch, a camera, a gyroscope, a proximity sensor, and a plethysmographic sensor.

20. The method of claim **15**, wherein the cyclically-varying arterial blood volume oscillates in magnitude between a maximal size and a minimal size at a rate equal to a difference between the HR and a rate of performance of the rhythmic musculoskeletal activity.

21. The method of claim **15**, wherein the instantaneous behavior of the second measured characteristic is one of: an increasing modulation amplitude, an increasing peak amplitude, an increasing average amplitude, a decreasing waveform complexity, and a change in timing of an aspect of the signal that repeats at the HR of the user.

* * * * *

专利名称(译)	用于协调肌肉骨骼和心血管血液动力学的系统和方法		
公开(公告)号	US20180296157A1	公开(公告)日	2018-10-18
申请号	US16/015636	申请日	2018-06-22
[标]申请(专利权)人(译)	PULSON		
申请(专利权)人(译)	PULSON INC.		
当前申请(专利权)人(译)	PULSON INC.		
[标]发明人	BLEICH JEFFERY LEE MANNHEIMER PAUL DAVID		
发明人	BLEICH, JEFFERY LEE MANNHEIMER, PAUL DAVID		
IPC分类号	A61B5/00 A61B5/0205 A61B5/0295 A61B5/026 A61B5/029 A61B5/0476 A61B7/04 A61B5/0488 A63B22/02 A63B22/06 A63B24/00		
CPC分类号	A61B5/486 A61B5/0205 A61B5/0295 A61B5/0261 A61B5/029 A61B5/0476 A61B5/7246 A61B7/04 A61B5/0488 A63B22/02 A63B22/0605 A63B24/0062 A61B5/6803 A61B5/021 A61B5/024 A61B5/0833 A61B5/0836 A61B5/091 A61B5/14539 A61B5/14546 A61B5/0077 A61B2560/0223 A61B2562/0219 A61B2562/0247 A61B2562/0257 A63B2024/0065 A63B2230/04 A63B2230/10 A63B2230/20 A63B2230 /433 A63B2230/436 A61B5/1118 A61B7/00 A63B15/00 A63B21/002 A63B21/0023 A63B21/06 A63B22 /0023 A63B22/0056 A63B22/0076 A63B22/0235 A63B22/0664 A63B23/1218 A63B23/1236 A63B24 /0075 A63B24/0087 A63B69/0028 A63B2024/0093 A63B2024/0096 A63B2071/0625 A63B2071/0655 A63B2071/0663 A63B2071/0677 A63B2220/10 A63B2220/17 A63B2220/30 A63B2220/40 A63B2220 /56 A63B2220/62 A63B2220/805 A63B2220/806 A63B2220/833 A63B2220/836 A63B2220/89 A63B2225/50 A63B2225/54 A63B2230/045 A63B2230/062 A63B2230/207 A63B2230/425 A63B2230 /50 A63B2230/60 A63B2230/75 A63B2244/20 G09B19/0038		
优先权	15/515118 2017-03-28 US PCT/US2015/052326 2015-09-25 WO 62/056730 2014-09-29 US		
其他公开文献	US10674958		
外部链接	Espacenet USPTO		

摘要(译)

本文描述了用于有利地协调肌肉骨骼活动周期与用户的心动周期之间的定时关系的系统和方法。一种方法可以包括重复检测与用户的血容量相关的信号;确定随时间关系变化的信号的实际值;计算信号实际值的趋势;并根据实际值的趋势调整运动指导。一种系统可以包括提示装置,该提示装置被配置为周期性地向用户提供运动指导以指导节律性肌肉骨骼活动的表现;传感器,被配置为提供与用户的血量相关的信号;处理器,被配置为确定随定时关系变化的信号的实际值,并基于实际值的趋势调整移动引导。

