



(19) **United States**

(12) **Patent Application Publication**  
**Henderson et al.**

(10) **Pub. No.: US 2017/0311824 A1**

(43) **Pub. Date: Nov. 2, 2017**

(54) **NON-INVASIVELY MONITORING BLOOD PARAMETERS**

*A61B 5/00* (2006.01)

*A61B 5/00* (2006.01)

*A61B 5/00* (2006.01)

(71) Applicant: **Covidien LP**, Mansfield, MA (US)

(52) **U.S. Cl.**

(72) Inventors: **Leslie G. Henderson**, Cicero, IN (US);  
**Theodore M. Bailey**, Indianapolis, IN (US)

CPC ..... *A61B 5/02416* (2013.01); *A61B 5/6814* (2013.01); *A61B 5/021* (2013.01); *A61B 5/6838* (2013.01); *A61B 5/6826* (2013.01); *A61B 5/0059* (2013.01); *A61B 5/14552* (2013.01); *A61B 5/14551* (2013.01); *A61B 5/02125* (2013.01); *A61B 5/6824* (2013.01); *A61B 2560/0412* (2013.01)

(21) Appl. No.: **15/649,908**

(22) Filed: **Jul. 14, 2017**

**Related U.S. Application Data**

(63) Continuation of application No. 12/248,683, filed on Oct. 9, 2008, now abandoned, Continuation of application No. 12/025,564, filed on Feb. 4, 2008, now Pat. No. 9,380,951, Continuation of application No. 10/958,458, filed on Oct. 5, 2004, now Pat. No. 7,341,560.

**Publication Classification**

(51) **Int. Cl.**

*A61B 5/024* (2006.01)

*A61B 5/021* (2006.01)

*A61B 5/00* (2006.01)

*A61B 5/00* (2006.01)

*A61B 5/1455* (2006.01)

*A61B 5/1455* (2006.01)

*A61B 5/021* (2006.01)

(57) **ABSTRACT**

An apparatus for monitoring vital sign parameters in a biological entity is disclosed. In an embodiment, the apparatus includes at least one light source for transmitting light through the biological entity and at least one photodetector for receiving light transmitted through the biological entity. At least one light source and at least one photodetector are configured to be positioned proximate the biological entity in a manner that does not significantly impede blood flow through the biological entity. A signal is generated in response to the transmittance or reflectance of light through the biological entity. The signal corresponds to at least one characteristic of the generally unimpeded blood flow through the biological entity. The apparatus also includes a control system configured to analyze the signal to determine vital sign parameters in the biological entity. A method for monitoring vital sign parameters in a biological entity is also provided.

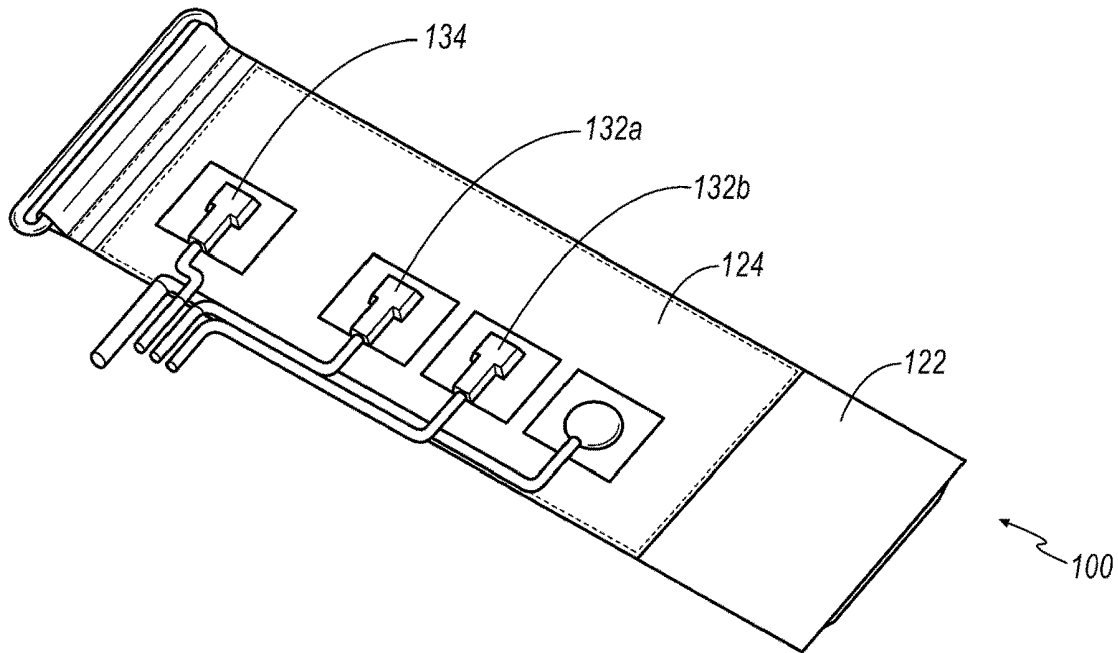

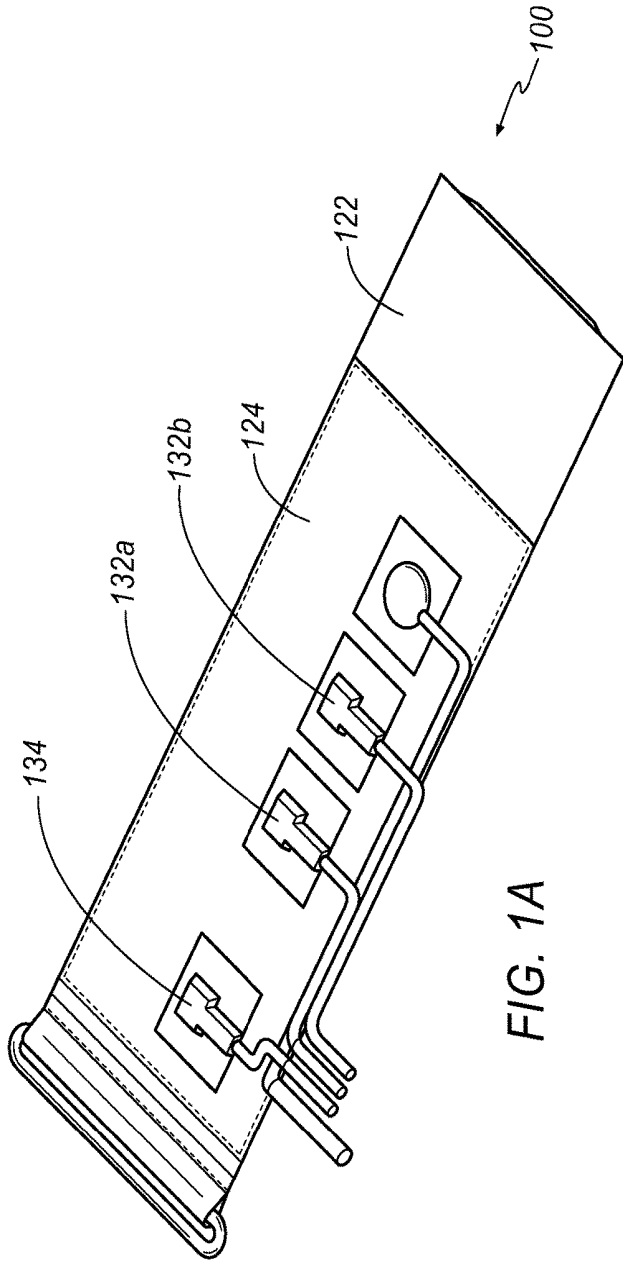

FIG. 1A

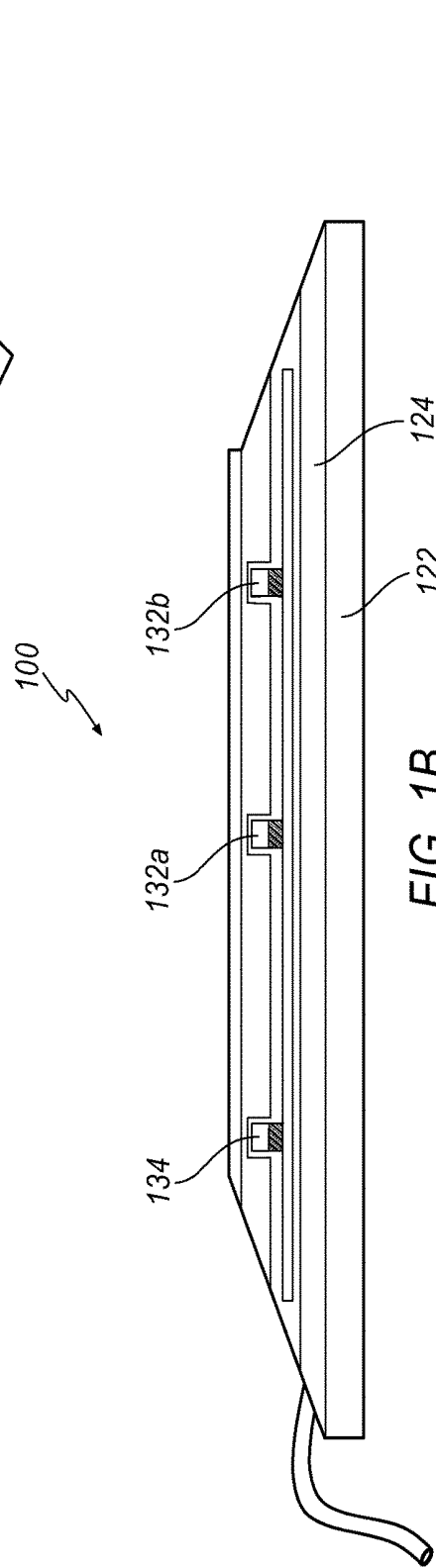
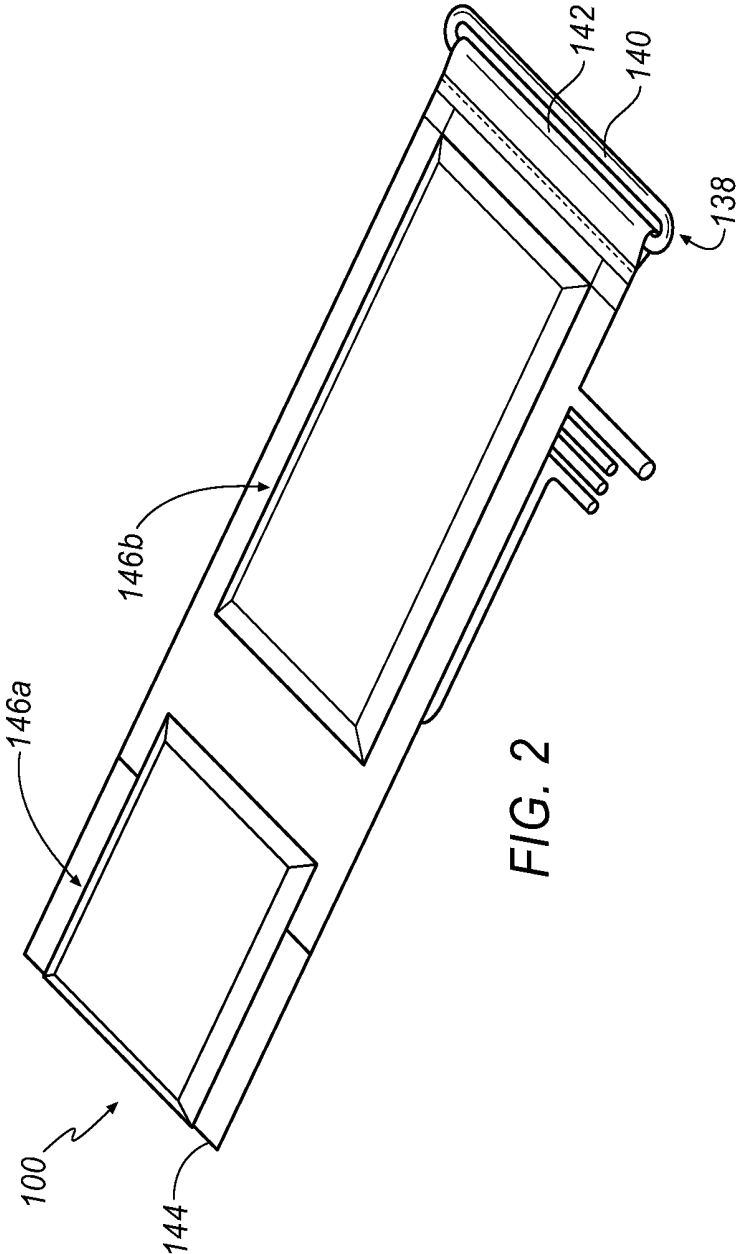

FIG. 1B



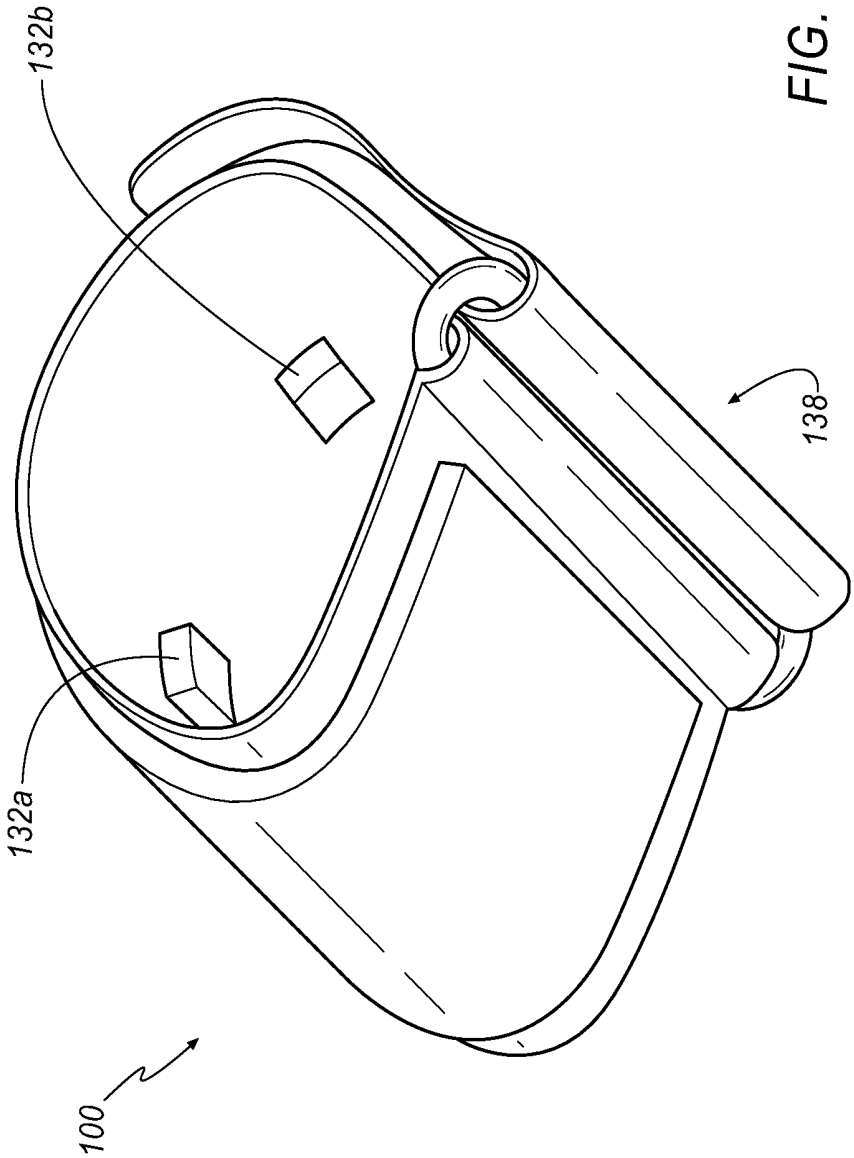
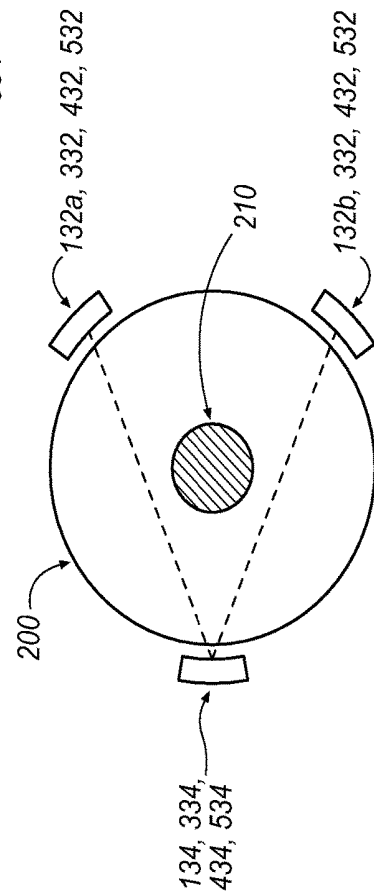
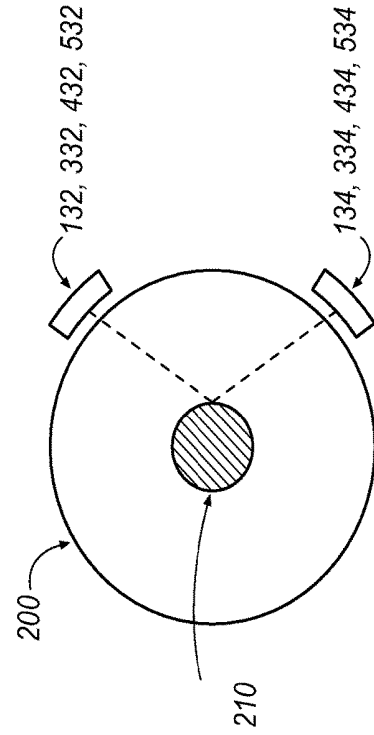
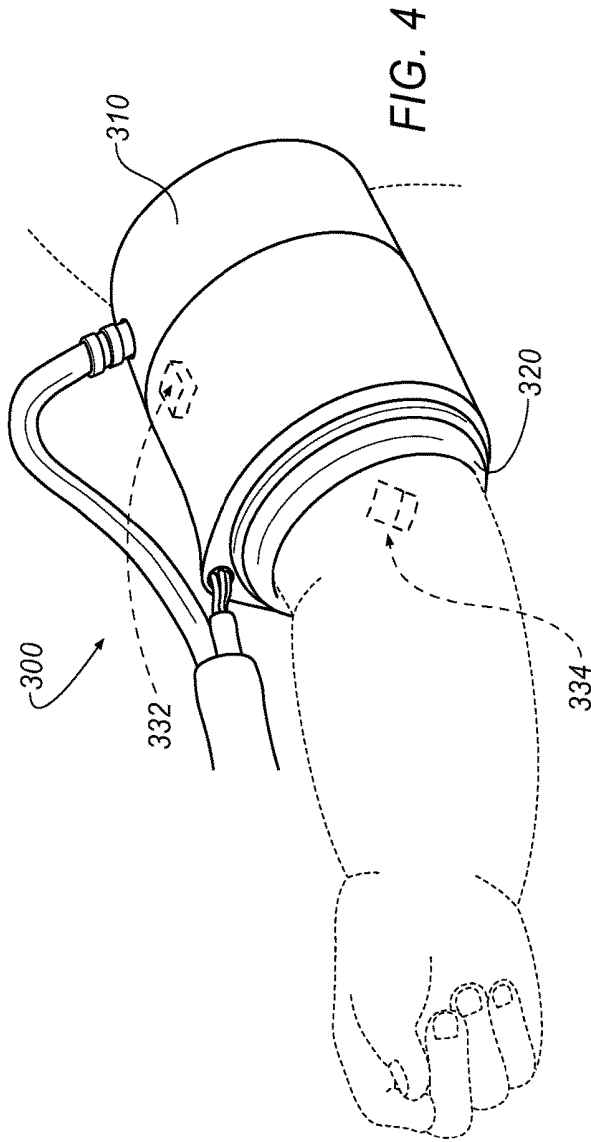
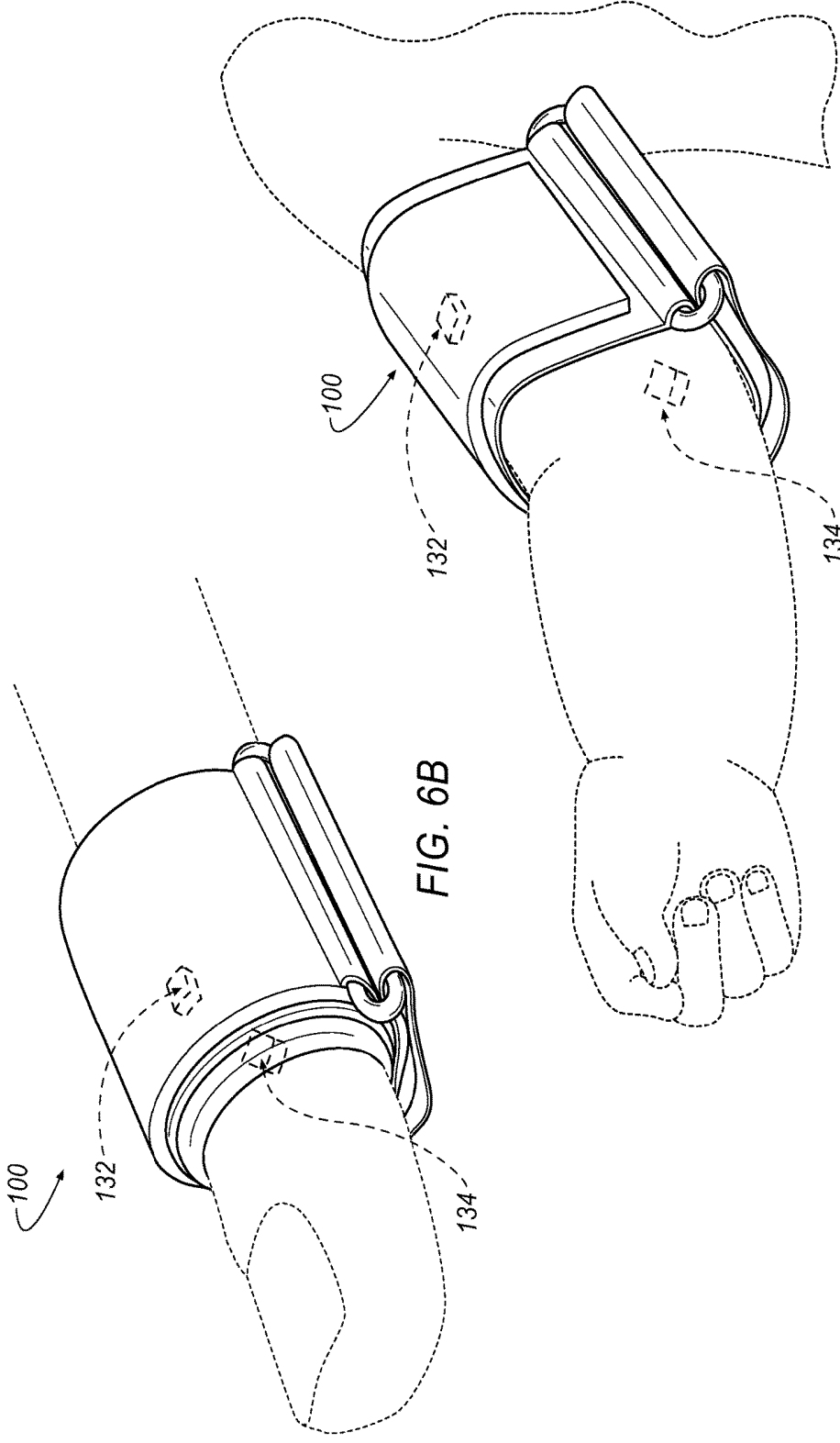

FIG. 3





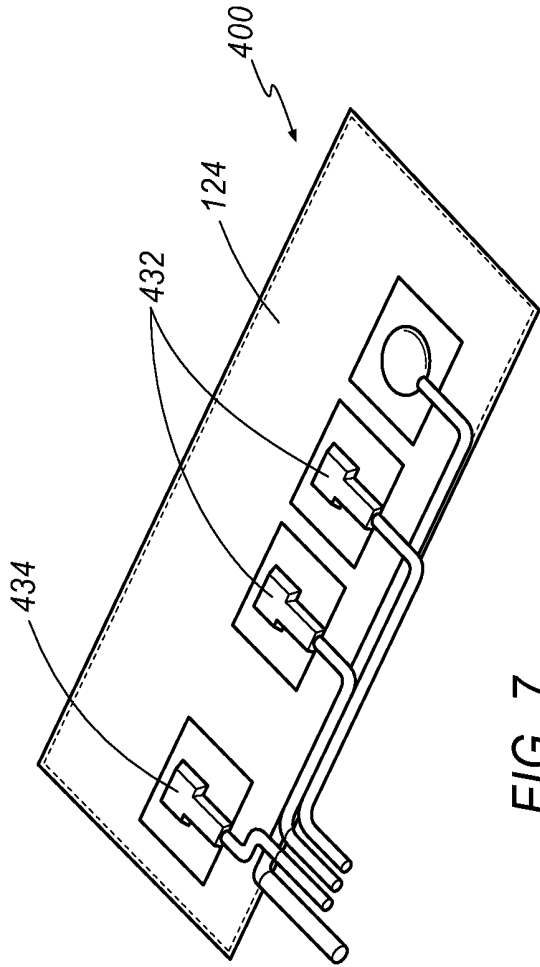

FIG. 7

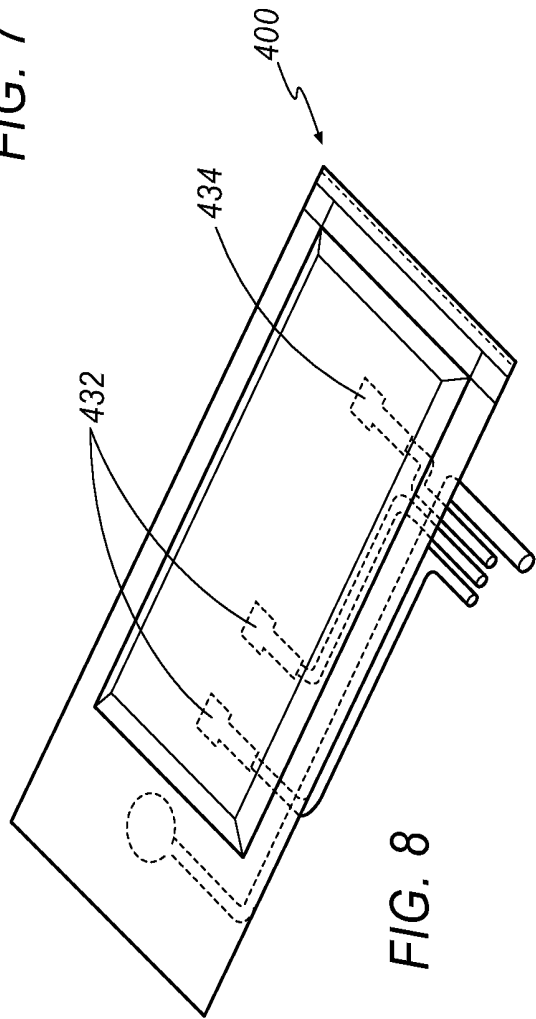

FIG. 8

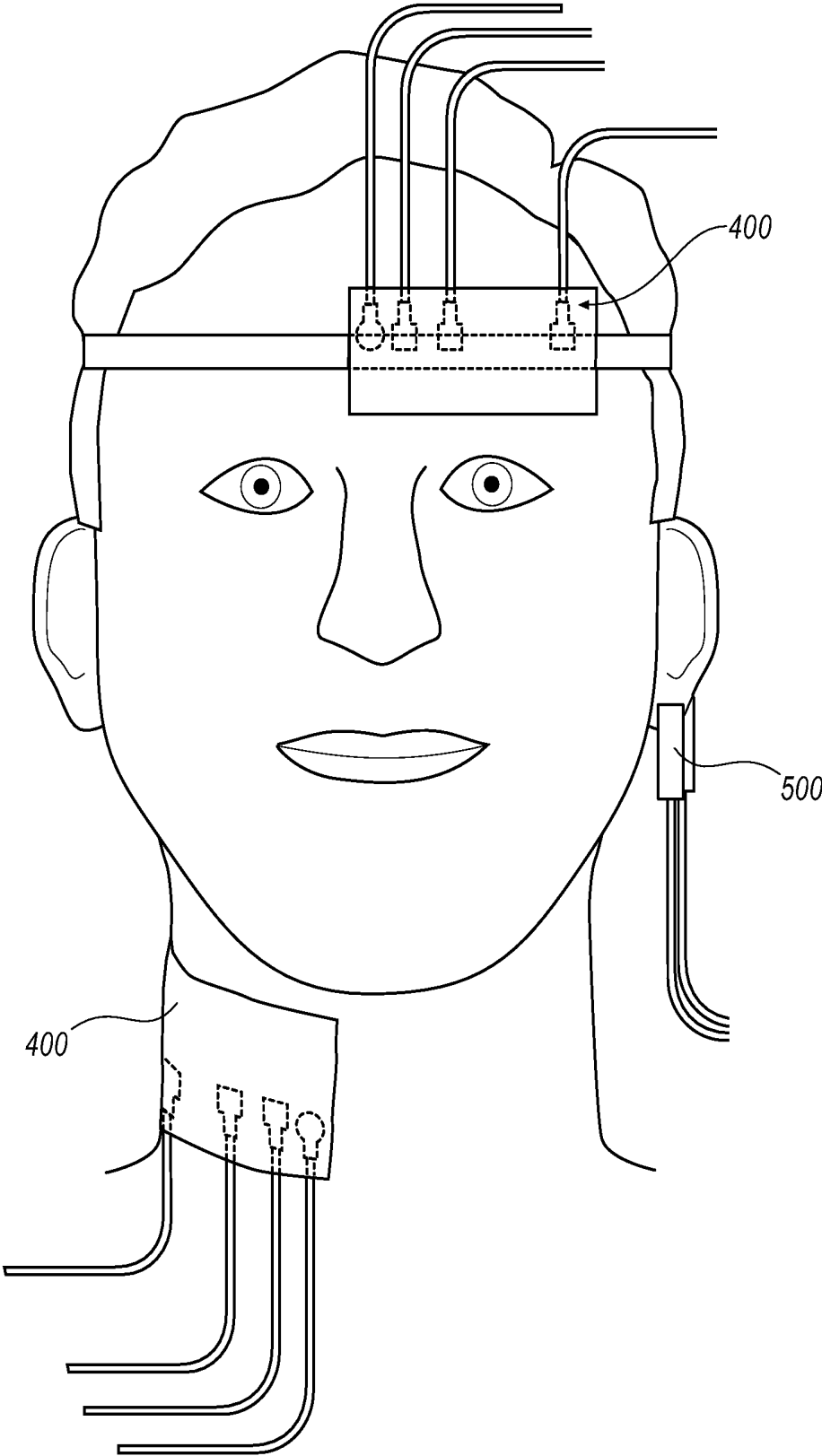

FIG. 9

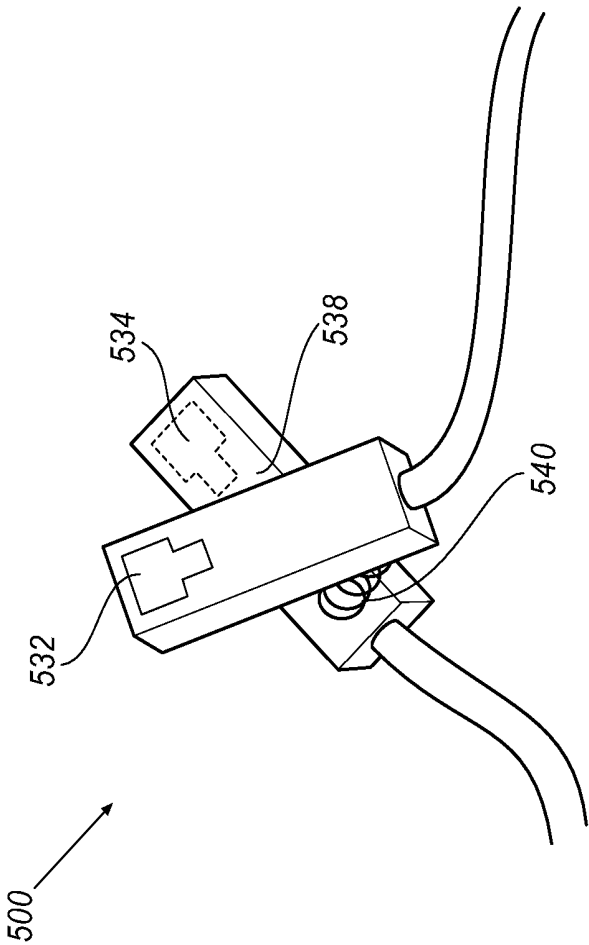

FIG. 10

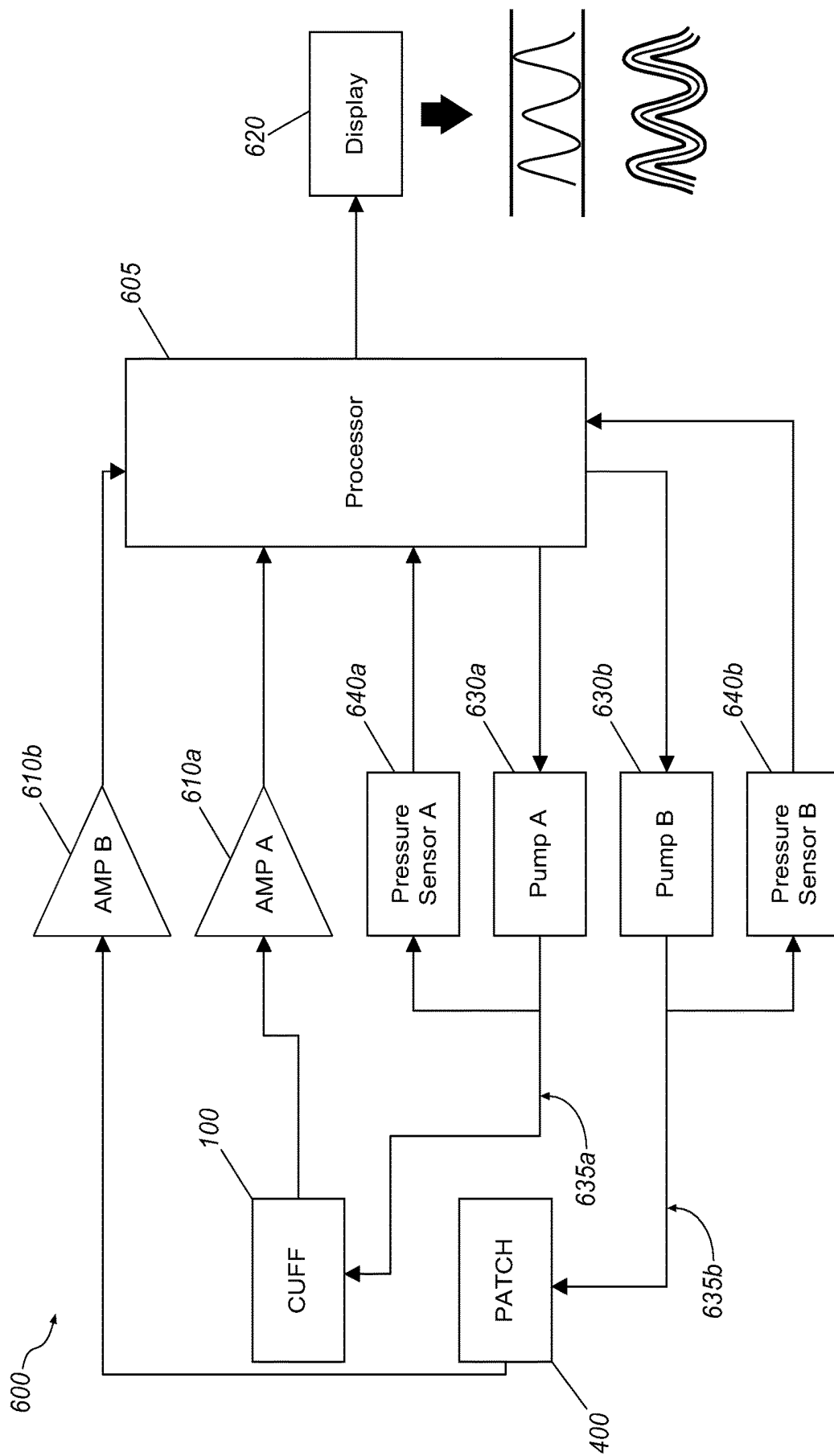

FIG. 11

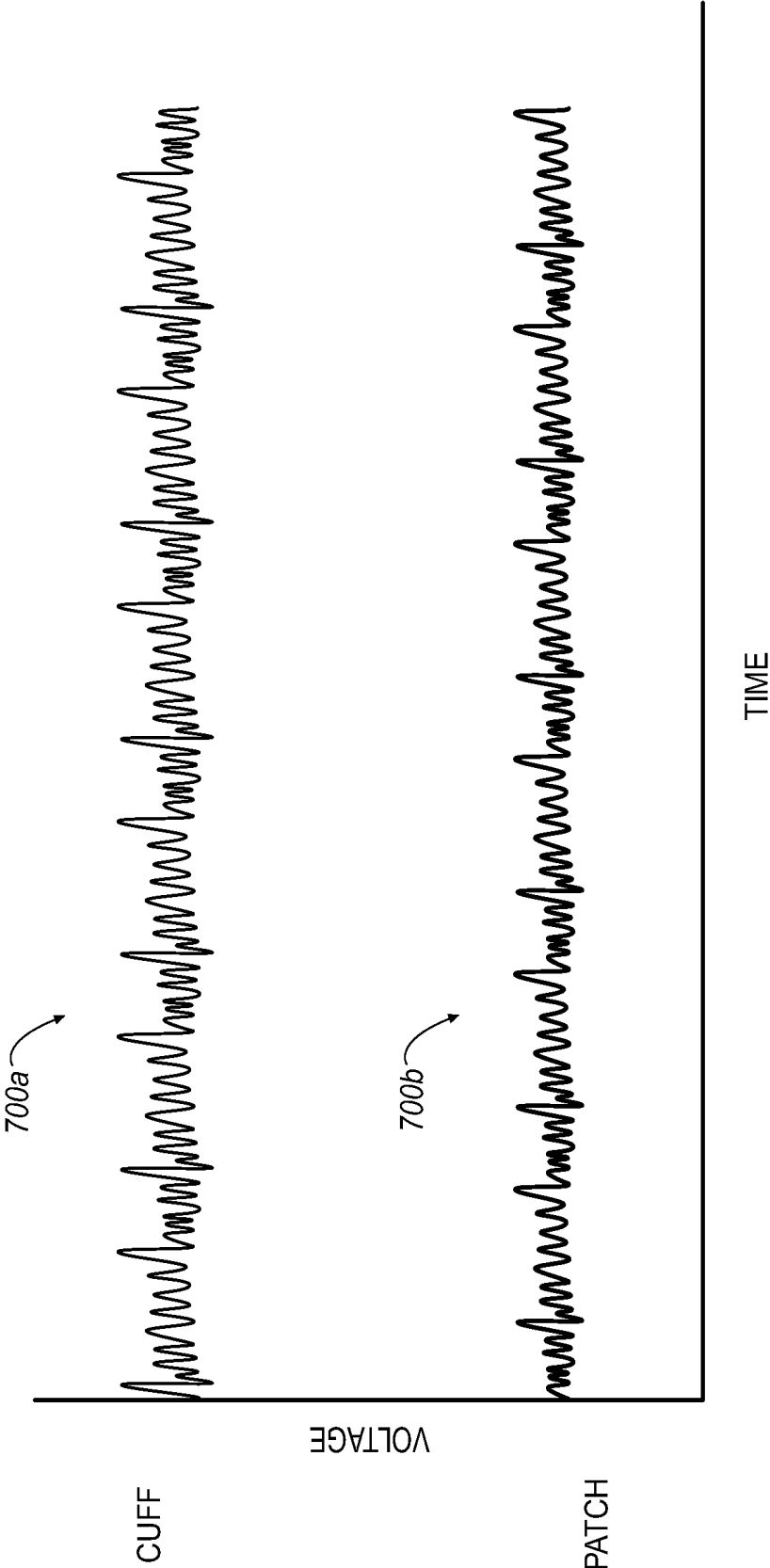

FIG. 12A

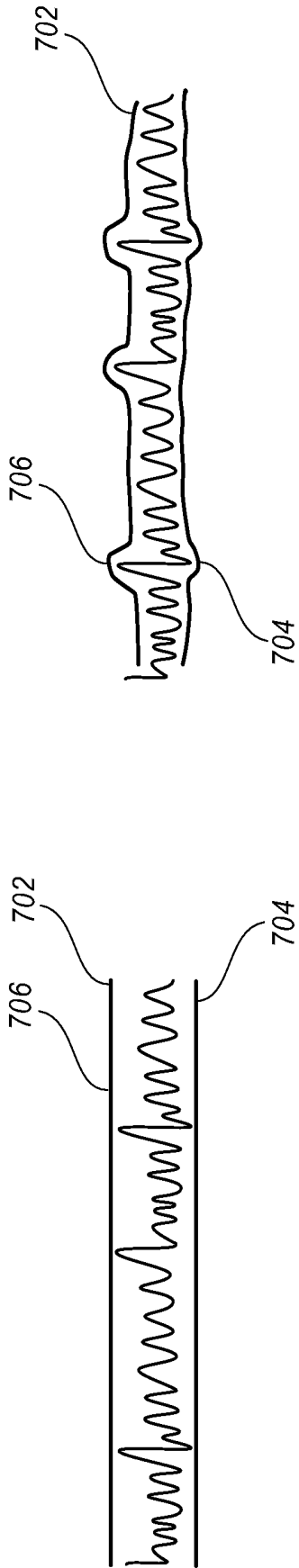

FIG. 12B

FIG. 12C

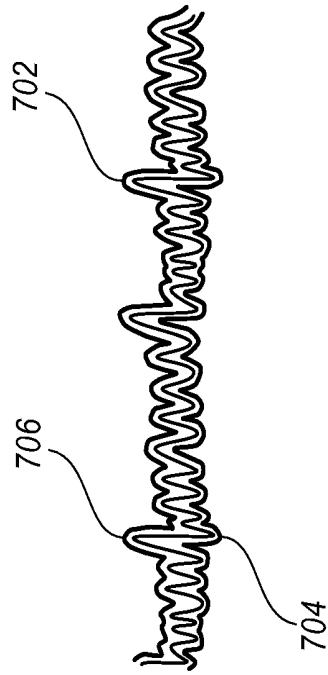

FIG. 12D

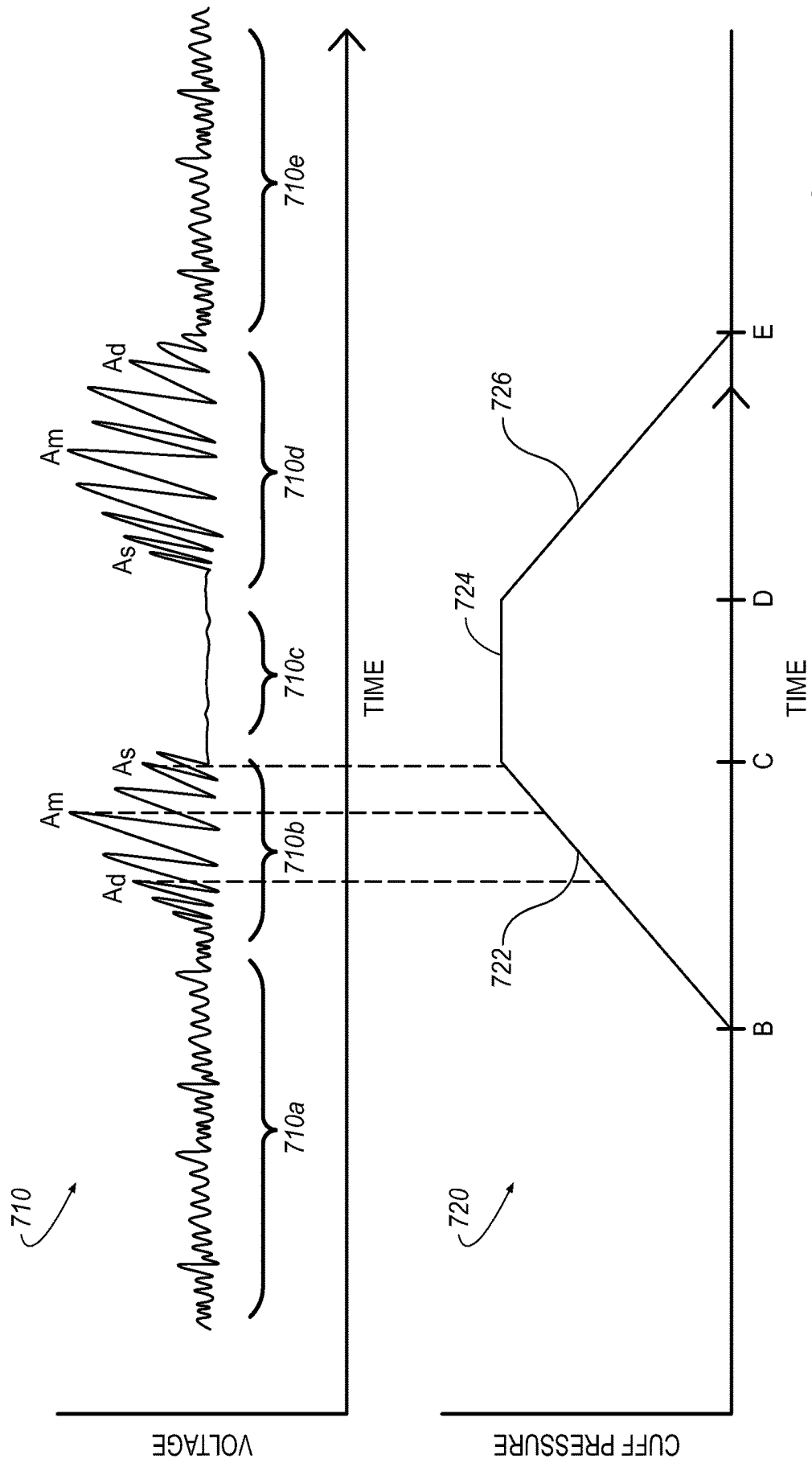

FIG. 13A

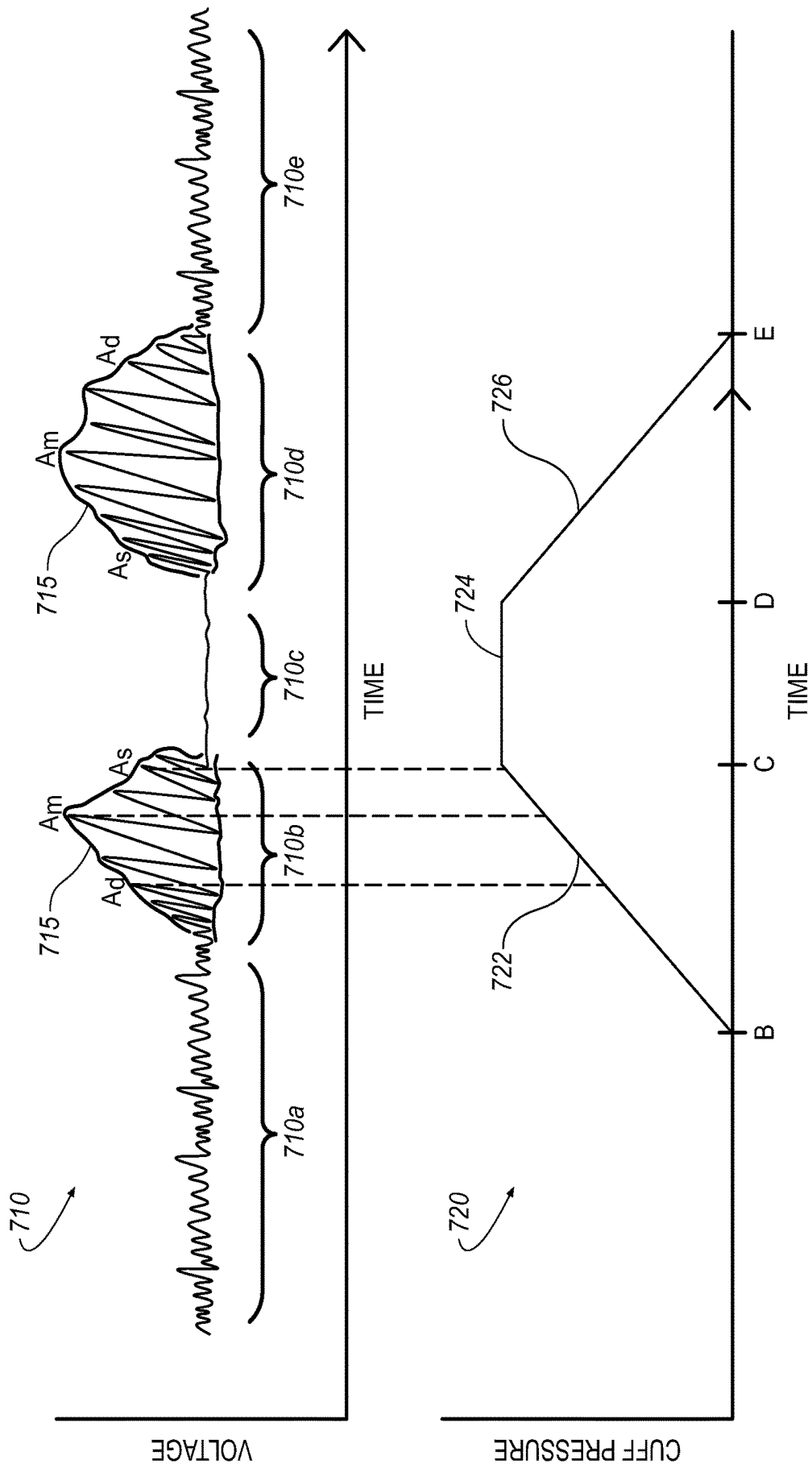
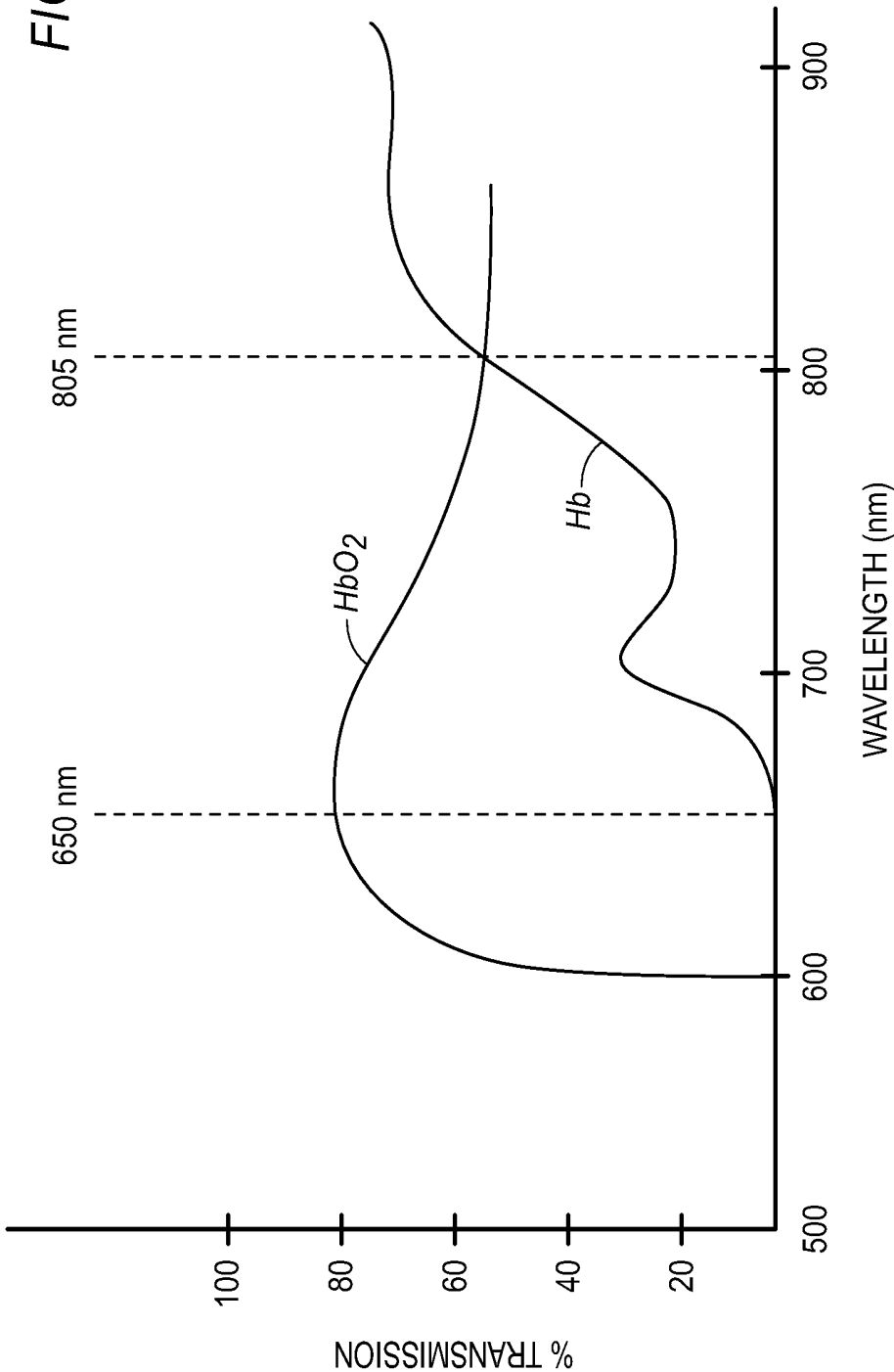

FIG. 13B

FIG. 14



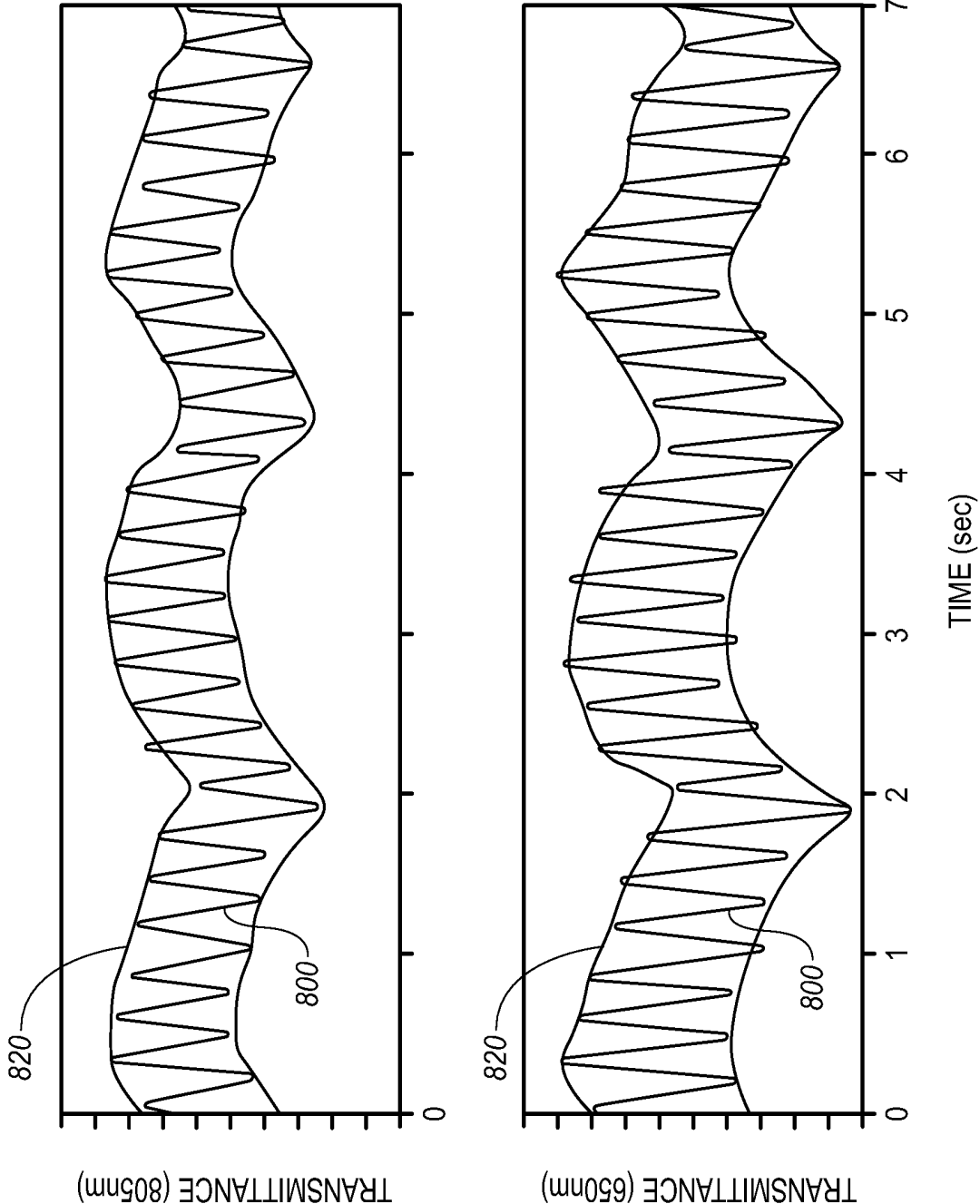

FIG. 15

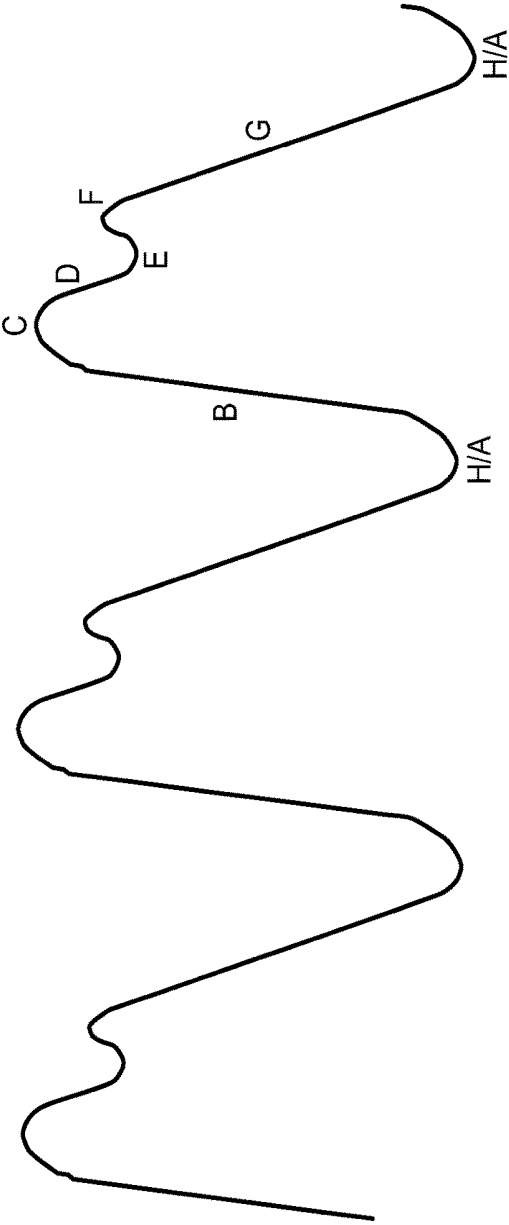

FIG. 16A



FIG. 16B

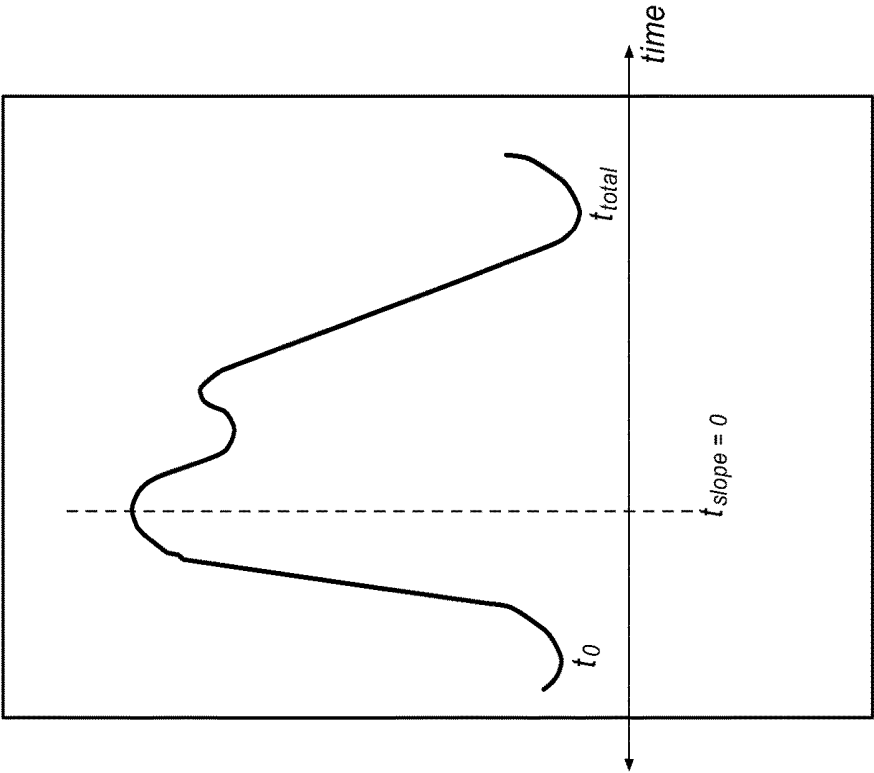
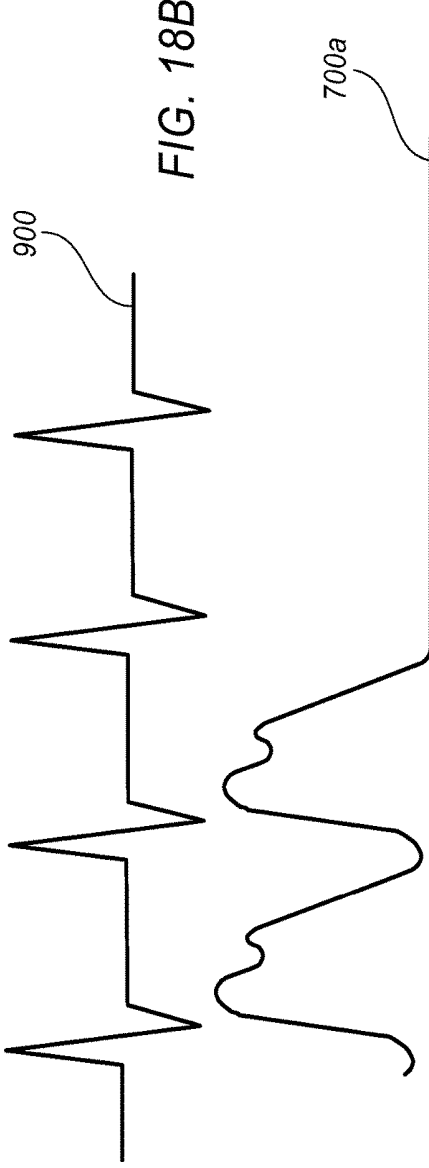
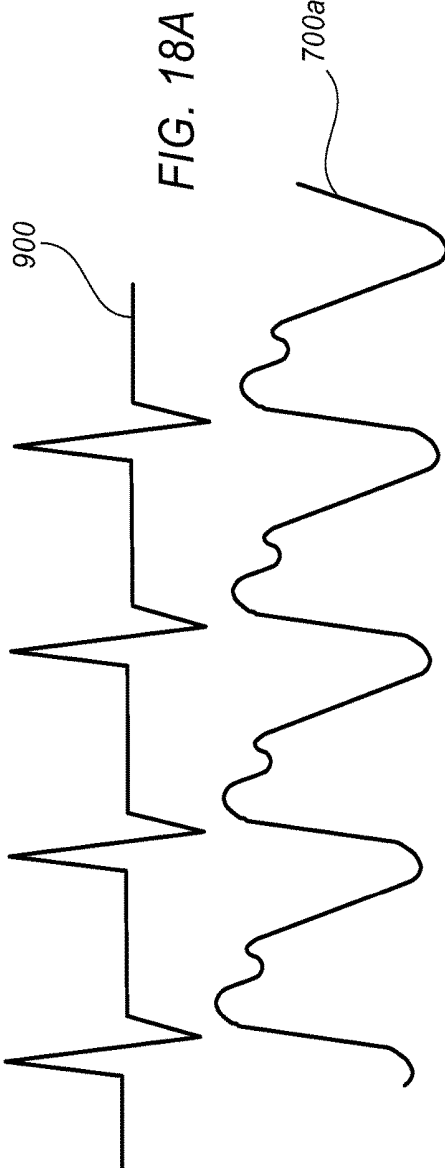

FIG. 17



## NON-INVASIVELY MONITORING BLOOD PARAMETERS

### FIELD OF THE INVENTION

[0001] The present invention relates to medical devices and, more particularly, to apparatuses and methods for non-invasively monitoring vital sign parameters of a biological entity, such as a neonate.

### BACKGROUND OF THE INVENTION

[0002] A basic requirement in determining the health of a human adult or neonate is to measure certain vital sign parameters, such as blood pressure, pulse rate, blood oxygen saturation, and respiratory rate. For example, measuring blood pressure in a human adult is typically accomplished using either an oscillometric-based method or an auscultatory method, both of which traditionally involve the application of an inflatable blood pressure cuff around the arm of the subject. While oscillometric-based and auscultatory methods are easily implemented with a human adult, these methods are not well suited for subjects such as neonates due to their diminutive size and inability to comprehend and cooperate with the procedure.

[0003] Beyond the inability to accurately monitor vital sign parameters in a small subject, traditional methods of measuring vital sign parameters are generally carried out on a periodic basis, as opposed to providing near-continuous monitoring. This is because traditional methods of monitoring generally required that the subject be disturbed in some manner. For example, in monitoring blood pressure, blood flow through the subject's body member was occluded, through inflation of the blood pressure cuff, in order to measure blood pressure. Inflation of the blood pressure cuff may be disturbing to a neonate, particularly during their rest if performed on a periodic basis.

[0004] Accordingly, a need exists for apparatuses and methods for monitoring vital sign parameters, such as blood pressure, oxygen saturation, pulse rate, and respiration, regardless of whether the subject is a human adult, a neonate or some other biological entity. The apparatuses and methods should be easily implemented and obtain accurate results, as well as be carried out in a near-continuous manner so as to allow for monitoring without disturbing the subject. Also, the apparatuses and methods should be employed such that any biological entity, regardless of size, may be monitored.

### SUMMARY OF THE INVENTION

[0005] The present invention provides apparatuses for monitoring vital sign parameters of a biological entity. In one embodiment of the invention, the apparatuses include at least one light source for transmitting light through the biological entity and at least one photodetector for receiving light transmitted through the biological member. At least one light source and at least one photodetector are configured to be positioned proximate the biological entity in a manner that does not significantly impede blood flow through the biological entity. A signal is generated in response to the transmittance or reflectance of light through the biological entity. The signal corresponds to at least one characteristic of the generally unimpeded blood flow through the biological member. The apparatuses also include a control system configured to analyze the signal to determine blood pressure,

oxygen saturation, pulse rate, perfusion index, cardiac index, vascular elasticity, and respiration, among other blood parameters, of the biological entity.

[0006] The present invention also provides methods for monitoring vital sign parameters in a biological entity. In one embodiment, the method includes positioning at least one sensor assembly proximate the biological entity. A signal is generated by at least one sensor assembly that corresponds to at least one characteristic of the blood flow through the biological entity. The signal is analyzed to determine blood pressure, oxygen saturation, pulse rate, perfusion index, cardiac index, vascular elasticity, and respiration, among other blood parameters, of the biological entity.

### DESCRIPTION OF THE DRAWINGS

[0007] Embodiments of the invention will now be described, by way of example, with reference to the accompanying drawings, wherein:

[0008] FIG. 1A depicts, from a first perspective, a trans-illuminating cuff according to an embodiment of the invention;

[0009] FIG. 1B is a cross-sectional view of the trans-illuminating cuff of FIG. 1A;

[0010] FIG. 2 is a view of the trans-illuminating cuff of FIG. 1A from a second perspective;

[0011] FIG. 3 is a depiction of the trans-illuminating cuff of FIG. 1A from a third perspective;

[0012] FIG. 4 is a perspective view of a trans-illuminating cuff according to another embodiment of the invention;

[0013] FIGS. 5A and 5B depict two possible optical paths that may be established through a biological member;

[0014] FIG. 6A is a perspective view of the trans-illuminating cuff of FIG. 1A applied to the arm of a neonate;

[0015] FIG. 6B, is a perspective view of the trans-illuminating cuff of FIG. 1A applied to the finger of an adult;

[0016] FIG. 7 depicts, from a first perspective, a trans-illuminating patch according to another embodiment of the invention;

[0017] FIG. 8 is a view of the trans-illuminating patch of FIG. 7 from a second perspective;

[0018] FIG. 9 is a front elevational view of the trans-illuminating patch of FIG. 7 applied to the head and neck of an adult;

[0019] FIG. 10 is a perspective view of a trans-illuminating clip according to another embodiment of the invention;

[0020] FIG. 11 is a block diagram of a vital sign parameter control system incorporating the trans-illuminating cuff of FIG. 1A and the trans-illuminating patch of FIG. 7;

[0021] FIG. 12A are exemplary pulse waveform signals obtained from the use of the trans-illuminating cuff of FIG. 1A and the-trans-illuminating patch of FIG. 7 with a biological member, such as the arm or head of a neonate;

[0022] FIGS. 12B-12D are exemplary pulse waveform signals of FIG. 12A that have been positioned within an analysis envelope;

[0023] FIGS. 13A and 13B are further exemplary pulse waveform signals illustrating optical oscillometric blood pressure measurements with a vital sign monitor;

[0024] FIG. 14 is a graph that illustrates the spectral characteristics of hemoglobin (Hb) and oxygenated hemoglobin (HbO<sub>2</sub>);

[0025] FIG. 15 illustrates the presence of respiratory variations in the graphs of transmittance of light of first and second wavelengths;

[0026] FIGS. 16A and 16B is an exemplary pulse waveform signal that has been labeled to define areas of interest that are related to the pumping action of a heart;

[0027] FIG. 17 is an enlarged exemplary pulse waveform signal of FIG. 12A to illustrate transition points of the signal; and

[0028] FIGS. 18A and 18B are exemplary electrocardiogram signals and an exemplary pulse waveform signals shown for comparison purposes.

#### DETAILED DESCRIPTION OF THE INVENTION

[0029] One embodiment of the present invention will now be described with reference to FIGS. 1-3. Illustrated in FIG. 1A is one side of a member trans-illuminating cuff 100 for monitoring certain vital sign parameters of a biological entity. A particular biological entity that is discussed in the several embodiments is a newborn, neonate, or infant (collectively referred to as "neonate" for the remainder of the application and understood to represent not only a person in their early stages of life, but any person of relatively diminutive size, such as an infant, regardless of age). Although the following describes these several embodiments in use with a neonate, it must be understood that these embodiments may also be used to monitor the vital signs of other biological entities such as an adult person or animals (e.g., canines and primates).

[0030] In the illustrated embodiment, cuff 100 includes a flexible support member 122 that can be readily wrapped or applied around an arm, leg, finger or other appendage (collectively referred to as a "limb" for the remainder of the application) of a biological entity. Incorporated within or mounted upon one side of cuff 100 is at least one light source 132 and at least one photodetector 134 positioned to diametrically oppose light source 132 when cuff 100 is applied over a limb of a neonate. One suitable type of light source for use in cuff 100 is a light emitting diode (LED), such as the type L660/805/975-40D00, available from Epitex, Kyoto, Japan, and a suitable photodetector is a photoresistor or photodiode, such as the QSD723 photoresistor available from QT Optoelectronics. However, other light sources and photodetectors for generating and receiving one of more frequencies of light may also be used in cuff 100 without departing from the spirit and scope of the invention.

[0031] In the embodiment illustrated in FIGS. 1-3, cuff 100 includes two light sources 132a and 132b that are spaced along the interior side of cuff 100 so as to oppose photodetector 134 when cuff 100 is applied over a limb 200 (see, e.g., FIG. 5A). This dual light source configuration provides for increased transmission of light through the tissue bed and around a bone 210 of limb 200. Alternatively, light source 132 and photodetector 134 may be positioned side-by-side to allow for the monitoring of blood parameters based not on light transmitted directly from the light source 132 to the photodetector 134, but instead on light transmitted into the tissue of the limb 200 by light source 132 and subsequently reflected back to photodetector 134 (see, e.g., FIG. 5B).

[0032] As illustrated in FIG. 2, cuff 100 also includes an attachment device 138 for securing cuff 100 to limb 200 of a neonate. According to the present embodiment, attachment

device 138 includes a cinch-loop 140 attached to a first end 142 of the flexible support member 122 through which a second end 144 extends when cuff 100 is applied to the limb of a neonate. In the illustrated configuration, hook-and-loop style fastener components 146a and 146b, such as Velcro, are applied to the second, or exterior, side of flexible support member 122. Once cuff 100 is applied to limb 200 of a neonate, fastener components 146a and 146b may be used to secure the cuff 100 in its wrapped position without significantly impeding the flow of blood through the limb (see, e.g., FIGS. 6A and 6B). In an alternative embodiment, cuff 100 may lack a cinch-loop 140, relying entirely on hook-and-loop style fastener components 146a and 146b to secure cuff 100. In addition, further embodiments may forgo the hook-and-loop style fastener components 146a and 146b in favor of other attachment means, such as, for instance, adhesives, reusable or otherwise, and other types of variable tension fastening systems.

[0033] In addition to light source 132 and photodetector 134, cuff 100 may optionally include one or more inflatable bladders 124 that are either incorporated into cuff 100 or mounted to an interior side of cuff 100. Upon placing cuff 100 around limb 200 of a neonate, bladder 124 may be inflated to a relatively low pressure level that would aid in securing cuff 100 in position while not significantly impeding the flow of blood through limb 200. Alternatively, as will be discussed later, it may be desirable to include a bladder 124 that may be inflated to a sufficiently high enough pressure level to temporarily obstruct the flow of blood through limb 200.

[0034] Regardless of either of the above intended functions, the addition of a bladder 124 to cuff 100 may be done in such a manner as to ensure that light source 132 and photodetector 134 optically communicate with limb 200. For illustrative purposes, consider the following two embodiments. In a first embodiment, bladder 124 mounts to an interior side of cuff 100 over light source 132 and photodetector 134. To ensure that neither light source 132 nor photodetector 134 are obstructed, bladder 124 may be fashioned from a material, such as polyurethane, which is optically transparent to the wavelength of light emitted by light source 132 and to which photodetector 134 is sensitive. Alternatively, according to another embodiment, cuff 100 may incorporate a bladder 124 in such a manner that when bladder 124 is inflated, light source 132 and photodetector 134 remain in contact with or proximal to limb 200. This can be accomplished, for example, by configuring cuff 100 so that light source 132 and photodetector 134 are mounted not upon flexible support member 122, but upon bladder 124.

[0035] According to another embodiment of the invention, flexible support member 122 may include a generally cylindrical sleeve (not illustrated) that may be slipped around the limb 200 of a neonate. To accommodate limbs 200 of different sizes, the generally cylindrical sleeve may possess elastic characteristics that allow it to stretch and contract as a limb 200 is inserted into the sleeve. The contractile forces generated by the sleeve as it is slipped around a limb 200 also serve to secure the placement of the sleeve without significantly impeding blood flow through the limb.

[0036] In still another embodiment of the invention, flexible support member 122 may include a generally cylindrical sleeve that does not have elastic characteristics. Instead, at least one bladder 124 may be incorporated into the sleeve or mounted upon the interior surface of the sleeve. Once sleeve

is slipped around the limb **200** of a neonate, bladder **124** may be inflated with sufficient pressure to secure the sleeve around the limb without significantly impeding blood flow. If desired, the bladder may also be inflated to a pressure exceeding the systolic blood pressure of the subject, thereby substantially obstructing the flow of blood through limb **200**.

[0037] According to yet another embodiment of the invention, an example of which is illustrated in FIG. 4, a trans-illuminating cuff **300** is provided that includes a rigid or semi-rigid housing **310**, such as a plastic tube, into which limb **200** of the neonate can be inserted. Similar to the previous embodiments, at least one light source **332** and at least one photodetector **334** are incorporated into or mounted upon housing **310** in such a manner that, upon insertion of limb **200**, light source **332** may transmit light through the tissue of limb **200**, with the transmitted light subsequently being received by photodetector **334**.

[0038] To ensure an adequate fit with different limb sizes, a resilient sleeve or layer of material **320** may be incorporated with, or mounted onto, the interior surface of housing **310**. Resilient layer **320** may include, for example, foam rubber and other materials that readily compress upon being pressed against limb **200**. In this manner, a fixed diameter housing **310** may accommodate various limb sizes, the resilient layer **320** compressing and expanding as needed to generally conform to the shape of limb **200**. As will be appreciated, resilient layer **320** may be configured so that it does not obstruct the transmission of light from light source **332** into the tissue of limb **200**, nor interfere with the reception of light by photodetector **334**. This can be accomplished through selective placement of resilient layer **320** or, alternatively, by making resilient layer **320** out of a material that is optically transparent to the wavelengths of light transmitted by light source **332** and received by photodetector **334**. In another configuration, light source **332** and photodetector **334** may be positioned on resilient layer **320** instead of housing **310**. In this manner, resilient layer **320** aids in positioning the light source **332** and photodetector **334** in close proximity to limb **200** as layer **320** expands and contracts in response to the presence of limb **200**.

[0039] In another configuration, housing **310** of cuff **300** may be configured so that resilient layer **320** is supplemented or replaced by at least one bladder (see, e.g., bladder **124**) that are selectively inflatable to a pressure level sufficient to hold housing **310** in place on limb **200** without significantly impeding the flow of blood through limb **200**. For reasons that will be described below, the bladder(s) may also be selectively inflated to a pressure exceeding the systolic blood pressure of the neonate, thereby substantially obstructing the flow of blood through limb **200**.

[0040] According to another embodiment of the invention, an example of which is illustrated in FIGS. 7 and 8, a trans-illuminating patch **400** is provided. Similar to previous embodiments, at least one light source **432** and at least one photodetector **434** are incorporated into or mounted upon patch **400**. Unlike the previous embodiments, patch **400** may be placed on any location or position of the neonate's body and used to monitor the vital sign parameters. Limb **200** may be used for placement, but is not required. Patch **400** may be positioned on the neonate's head, chest, neck, thigh, or other suitable location to monitor vital sign parameters (see e.g., FIG. 9, patch **400** is positioned on the head and neck of an adult person). Patch **400** may be attached to the particular

area of the body with adhesives, reusable or otherwise, or some other attachment device such as a bandage, headband, or the like.

[0041] Patch **400** may be positioned on the neonate in relatively flat locations rather than encircling limb **200** like cuffs **100**, **300**. Therefore, light source **432** and photodetector **434** may be positioned side-by-side to allow for monitoring of vital sign parameters based not on light transmitted directly from the light source **432** to photodetector **434**, but instead on light transmitted into the tissue of the neonate's body by light source **432** and subsequently reflected back to photodetector **434** (see, e.g., FIG. 5B).

[0042] In addition to light sources **432** and photodetector **434**, patch **400** may also include one or more inflatable bladders (see, e.g., bladder **124**) that are incorporated into patch **400**. The bladders may be mounted to patch **400** such that the bladders may be between the neonate and the patch **400**. In this case, the bladders may be fashioned from a material, such as polyurethane, which is optically transparent to the wavelength of light emitted by light sources **432** and to which photodetector **434** is sensitive. As will be discussed later, the bladders may be selectively inflated to a pressure exceeding the systolic blood pressure of the neonate, thereby substantially obstructing the flow of blood through that particular area of the neonate's body.

[0043] According to another embodiment of the invention, an example of which is illustrated in FIG. 10, a trans-illuminating clip **500** is provided. Similar to previous embodiments, at least one light source **532** and at least one photodetector **534** are incorporated into or mounted upon clip **500**. Clip **500** may be secured to smaller portions of the body such as earlobes, fingers, toes, and the like, and used to monitor the vital sign parameters. (see e.g., FIG. 9, clip **500** is positioned on the earlobe of an adult person). Clip **500** includes an attachment device **538** that includes a biasing member **540** such as a spring, resilient rubber, or the like, to ensure that light source **532** and photodetector **534** remain proximate the tissue of the neonate.

[0044] With reference now to FIG. 11, a control system **600** of the present invention is shown. In an embodiment, control system **600** includes a processor **605** that controls, among other things, operation of light sources (e.g., **132**, **432**) and photodetectors (e.g., **134**, **434**) in a sensor assembly (e.g. cuff **100**, patch **400**). Although the sensor assembly employing light sources and photodetectors is the preferred means of generating a signal relating to vital sign parameters, it must be understood that equivalent means for generating signals relating to vital sign parameters may be employed such as ultrasound or the like. Although control system **600** is discussed controlling two sensor assemblies, it should be understood that control system **600** may control multiple channels so that multiple sensor assemblies, that are positioned on a neonate, may be used in monitoring vital sign parameters.

[0045] During vital sign parameter measurements, for example, in the measuring of blood pressure, the microprocessor energizes the light sources continually. When activated, photodetectors convert the light transmitted through the tissue in limb **200** or reflected in head **450** (or other part of the body such as the neck, chest, or thigh) into a corresponding electronic signal. This electronic signal is subsequently supplied to processor **605** for analysis after being optionally passed through amplifiers **610a** and **610b**. The amplified photodetector output signal is converted to

digital form in the microprocessor itself if the microprocessor has an internal A/D converter, or in a separate A/D converter provided between the amplifier and the microprocessor. Results of the analysis may then be directed to a variety of output devices, such as, for example, a display screen 620. In the embodiment illustrated in FIG. 11, processor 605 is depicted as being separate from the sensor assemblies. However, in an alternative embodiment, control system 600 may be more integrated into the sensor assemblies, with one or more of the components, including processor 605, being incorporated into the sensor assemblies.

[0046] The sensor assemblies may also communicate with pumps 630a, 630b if one or more inflatable bladders are included in the sensor assemblies. Inflation and deflation of the bladders may be readily controlled by pumps 630a, 630b. For example, according to one embodiment, pumps 630a, 630b are controlled by processor 605 and convey air into the inflatable bladders through inflation tubes 635a and 635b. Pressure transducers 640a and 640b may also be incorporated into control system 600 for monitoring the pressure in inflation tubes 635a and 635b and the bladders, and conveying signals indicative of such pressure back to the processor 605. Suitable transducers are available from Cobe Labs, Littleton, Colo.

[0047] Operation of the sensor assemblies in conjunction with control system 600 to monitor certain vital sign parameters of a neonate, will now be discussed with reference to FIG. 12A. Before any vital signs may be monitored, a first sensor assembly (e.g., cuff 100) is secured around limb 200 of a neonate (see, e.g., FIG. 6A) and a second sensor assembly (e.g., patch 400) is secured to the head of a neonate (see, e.g., FIG. 9). Once appropriately positioned, control system 600 activates the sensor assemblies by operating or energizing light sources (e.g., 132, 432) and photodetectors (e.g., 134, 434). Once energized, the light sources begin to transmit light of a first wavelength or frequency. This transmitted light, representing an optical signal, passes through the skin and into the tissue of limb 200 (see, e.g., FIG. 5A) and passes through the skin and is reflected off the skull in head 450 (see, e.g., FIG. 5B). The optical signal continues to travel through the tissue making up limb 200 and head 450, including, for example, various types of skin tissue, muscle, and blood vessels. As the optical signal travels through these various constituent tissues comprising limb 200 and head 450, portions of the signal are deflected or absorbed. The remainder of the optical signal that makes it through the tissue of limb 200 is received by the photodetector. The remainder of the optical signal that is reflected through the tissue of head 450 is received by the photodetector. The photodetectors subsequently convert the optical signals into electric signals to be sent to control system 600.

[0048] At any specific point in time, this electric signal produced by the photodetectors represents the transmittance (T) of the optical signal through the tissue of limb 200 and the reflectance (R) through the tissue of head 450 at that moment in time. This transmittance (T) or reflectance (R) of the optical signal is not constant, but continuously fluctuates due to ongoing changes occurring in the tissue of limb 200 and head 450, including without limitation, changes in blood flow. Specifically, blood is distributed throughout limb 200 and head 450 by a variety of blood vessels, including, for example, arteries and arterioles. The rate and volume of blood flow through these vessels is largely dependent on blood pressure levels, which in turn are dependent on the

pumping action of the heart as well as the blood vessels themselves, some of which constrict or dilate depending on the current biological state of the subject. Accordingly, the transmittance (T) of the optical signals through the tissue of limb 200 and reflectance (R) of the optical signals through the tissue of the head 450 are dependent on volumetric changes in blood flow, which, in turn, are dependent on blood pressure levels. Consequently, analysis of the electric signals, which represent variations in transmittance (T) or reflectance (R) of the optical signals due to volumetric changes in blood flow, permits the determination of several vital sign parameters, including without limitation, blood pressure oxygen saturation, pulse rate, perfusion index, cardiac index, vascular elasticity, and respiration.

[0049] Illustrated in FIG. 12A is a graphical representation of exemplary signals 700a, 700b (referred to for the remainder of the discussion as a pulse waveform signals) generated by the photodetectors. Pulse waveform signal 700a is obtained after securing the first sensor assembly around limb 200 and energizing the light source and the photodetector. A similar pulse waveform 700b is obtained after securing the second sensor assembly to head 450 and energizing the light source and the photodetector. The rhythmic pattern of fluctuations or oscillations within pulse waveform signals 700a, 700b represent changes in the volumetric flow of blood through limb 200 or head 450 primarily due to the pumping or "beating" action of the human heart.

[0050] Subsequent analysis of pulse waveform signals 700a, 700b permit the determination of certain blood parameters that influence the flow of blood, such as, for example, mean arterial blood pressure, diastolic blood pressure and systolic blood pressure. This determination is possible due to the relationships, as discussed above, between transmittance (T) of the optical signal and between reflectance (R) of the optical signal, volumetric changes in blood flow, and blood pressure levels. In an embodiment of the present invention, analysis of pulse waveform signals 700a, 700b includes the application of one or more algorithms that manipulate the data of pulse waveform signals 700a, 700b in accordance with one or more predefined relationships that exist between transmittance (T) and reflectance (R) of the optical signal, blood flow and blood pressure levels. This is further discussed below.

[0051] Now referring to FIGS. 12B-12D, the microprocessor may be suitably programmed to generate an envelope 702 from the pulse waveform signal. Envelope 702 is comprised of a lower band 704 and upper band 706 that may be positioned around subsequent pulse waveform signals. Envelope 702 may be used to further aid health care professionals in the near continuous monitoring of a neonate's vital sign parameters and for diagnostic analysis.

[0052] Microprocessor 605 may generate envelope 702 from pulse waveform signal 700a by using a signal sampling technique that is known in the art of signal processing. As the microprocessor generates a pulse waveform signal based on the electrical signal received from the sensor assembly (e.g., cuff, patch, clip, or other like device) used to monitor the neonate's vital sign parameters, the microprocessor may be programmed to "sample" the pulse waveform signal periodically. Sampling the pulse waveform signal produces a second signal that may be similar to the original pulse waveform signal. The number of samples taken and the time period between samples will determine how closely the sampled signal resembles the original pulse waveform signal

taken from the cuff, patch or other like device. Once the sample signal has been generated, the microprocessor may be programmed such that lower band 704 and upper band 706 may be developed from the sampled signal, as determined by a healthcare professional, by adjusting the signal gain to produce envelope 702.

[0053] For example, FIG. 120 illustrates envelope 702 that is a set of simple limit bars (lower band 704 and upper band 706) that are based on a sampled electrical signal from the sensor assembly. In this instance, microprocessor samples the pulse waveform signal at only a few points to identify the peak value of the pulse waveform signal. The microprocessor then sets the lower and upper bands of the envelope based upon the peak value or as directed by a healthcare professional. In FIG. 12C, envelope 702 more closely resembles the pulse waveform signal that was generated by the microprocessor from the electrical signal received from the sensor assembly. The envelope in FIG. 12C is based on more frequent sampling of the pulse waveform signal than the envelope in FIG. 12B. The envelope in FIG. 12D is based on an even greater frequency of sampling of the pulse waveform signal than the envelope in FIG. 12C so that the lower and upper bands more closely resemble the actual pulse waveform signal.

[0054] The sampling period of the microprocessor may be adjusted to be used in the manner determined by the health care professional. The greater the frequency of the sampling period, the greater the number of sampling points generated, and the more the envelope will resemble the actual electrical signal from the sensor assembly. In this manner the health care professional will have greater precision when employing the use of an envelope in a diagnostic analysis or a near continuous monitor mode.

[0055] Once lower band 704 and upper band 706 of envelope 702 have been determined, the health care professional may employ envelope 702 for a number of continuous monitoring and diagnostic analysis techniques. For example, an audible alert may be incorporated into control system 600 such that during continuous monitoring of a neonate with sensor assemblies, an alarm may be sounded if the incoming electrical signal crosses either lower band 704 or upper band 706 indicating a unwanted change in vital sign parameters.

[0056] Also, after the signal envelopes have been established, pulse waveform signal 700a may be analyzed through a process of comparing signal 700a to a number of previously established pulse waveform signals that have already been associated with one or more known vital sign measurements. Specifically, the present analysis method involves the creation of a database of reference envelopes based on previous pulse waveform signals and corresponding blood flow characteristics associated with the reference signals. Each individual envelope characteristic in the database or, alternatively, a combination of two or more envelope characteristics, is then associated with one or more vital sign measurements, such as, for example, blood pressure, respiration, and heart rate. A pulse waveform signal 700a undergoing analysis is evaluated for one or more identifiable and defining characteristics. These defining characteristics in the evaluated pulse waveform signal 700a are compared to the established envelope characteristics maintained in the database. If this comparison meets certain predetermined criteria between the characteristics of the pulse waveform signal 700a being analyzed and the specific reference characteristics stored in the database, it can be assumed that the

blood parameters associated with pulse waveform signal 700a are the same as the known blood parameters associated with the selected reference envelopes stored in the database. The known blood parameters corresponding to the monitored waveform signal 700a may then be presented to the healthcare provider, such as on display 620.

[0057] Additionally, the envelopes developed from the pulse waveform signals may be generated and stored in databases for an entire population. A generic database of envelopes may be developed that may be based on age, gender, size, or any number of attributes. By employing the use of these databases, health care professionals may be able to establish a base line reading for those people who have not had a medical physical in quite some time. Rather than taking several months or years to establish a baseline, a generic pulse waveform envelope baseline can be drawn from the database based on parameters such as size, age, and gender, and the person's pulse waveform signal monitored against established envelopes. While, every person will still require an individual assessment, irregularities may be identified in advance with the use of the generic database of envelopes that closely correspond to a particular person's size, age, gender, etc.

[0058] For those people that do visit their healthcare professional regularly, an individual database of envelopes may be developed for future diagnostic analysis. One example may involve a person who visits his health care professional for regular physicals. Each time the person returns his yearly physical, the healthcare professional can access his previous envelopes to be used in comparison purposes with the new pulse waveform signal that is presently being generated. The healthcare professional may be alerted to potential physiological problems if the new signal passes outside the envelope indicating a change in the person's vital sign parameters. In another example, a person may find himself in an accident where he is unconscious and cannot communicate with onsite health care professionals. Identification information about the victim can be entered into a computer and the onsite professionals can access the victim's database of pulse waveform signal envelopes to identify any of the victim's vital sign parameter abnormalities that may require attention prior to treating the victim. In this manner, people may receive a relatively quick and accurate diagnosis, which in turn leads to quick and more importantly the correct form of treatment.

[0059] Physiological markers that may be monitored and measured by these embodiments may include, but are not limited to, glucose levels, lactate, C-reactive protein, cytokines, white blood cell counts, and gene or protein expression in-vivo. These biological markers not only provide insight into the health status, but also address pre-symptomatic activity due to infection, chemical or biological agent exposure.

[0060] Microprocessor 605 may also compare pulse waveform signal 700a produced from the first sensor assembly positioned around limb 200 (see e.g., FIGS. 6A and 6B), with pulse waveform signal 700b produced from the second sensor assembly positioned on head 450 (see e.g., FIG. 9). As discussed above, a database of envelope signals may be created for comparison purposes. The health care provider may monitor these waveforms-taken from different areas of the subject to diagnosis possible internal biological problems that may be found between the monitoring devices. Also, the two separate sensor assemblies may be used in

conjunction with one another for vital sign comparison purposes and analysis of the neonate.

**[0061]** In addition to the embodiments discussed above, the sensor assembly may also be configured to actively measure blood pressure of a subject through an oscillometric-based method. According to this embodiment, the sensor assembly may include at least one inflatable bladder selectively operable to occlude blood flow in limb **200** or head **450** upon inflation to a sufficiently high enough pressure. An illustrative example of this embodiment will now be discussed with reference to FIGS. **13A** and **13B**, which depicts a pulse waveform signal **710** along with a graph **720** of corresponding sensor assembly pressure. As in the previous embodiments, a pulse waveform signal **710** is obtained by applying the sensor assembly around limb **200** or to head **450** of the subject and then subsequently energizing the light source to transmit an optical signal through the tissue of the limb or the head to the photodetector. When the bladders are in a deflated state, and thus not significantly impeding the flow of blood through limb **200** or head **450**, the sensor assembly will generate a first pulse waveform signal **710a** that is similar in nature to the pulse waveform signals **700a**, **700b** obtained in the previously discussed embodiment of the invention.

**[0062]** At time B, pump **630a**, **630b** (illustrated in FIG. **11**) activates, thereby increasing the pressure in the bladders, as illustrated in FIGS. **13A** and **13B** by graph segment **722**. As the bladder pressure increases, sensor assembly begins to constrict limb **200** or head **450**. This constriction causes at least a partial pinching of the blood vessels running through the limb or the head, which, in turn, impedes blood flow through the blood vessels. During this stage of increasing bladder pressure, the pulses or oscillations in the pulse waveform signal **710b** first increase in amplitude, reach a maximum, and then decrease in amplitude. Once the pressure in the bladder exceeds the systolic blood pressure; substantially all blood flow through the limb or head is terminated. The essential lack of blood flow through limb **200** or head **450** during this time period results in a near constant level of transmittance (T) of the optical signal traveling through the tissue of limb **200** or reflectance (R) of the optical signal traveling through the tissue of head **450**. As a result of this near constant transmittance (T) or reflectance (R), the pulse waveform signal becomes nearly constant (see, e.g., segment **710c**), exhibiting substantially no variances or oscillations in form. At time D, the bladder is allowed to deflate or depressurize at a predetermined rate, as indicated by graph segment **726**. The transition period DE in bladder pressure results in amplified oscillations or spikes in the pulse waveform signal (see, e.g., segment **710d**). As the sensor assembly returns to an un-pressurized state, the oscillations in the pulse waveform signal (see, e.g., segment **710e**) return to a substantially uniform level.

**[0063]** During both transient pressure stages, indicated in FIG. **13B** as stages **722** and **726**, respectively, the pulse waveform signal exhibits transient increases in the amplitude of the oscillations occurring in the signal (see, e.g., segments **710b** and **710d**). While the pressure is being increased and decreased by the microprocessor, the microprocessor is also sampling the incoming signal so that an envelope **715** may be generated based upon the transient signal. The positive peak of the envelope is at a point where the pulse amplitude reaches a maximum, identified as mean arterial blood pressure ( $A_m$ ) in FIGS. **13A** and **13B**. The

maximum amplitude of the pulse is also a point where the bladder pressure is substantially equal to mean arterial blood pressure. Similarly, there exist points in waveform signal segments **710b** and **710d** that correspond to diastolic blood pressure and systolic blood pressure. The determination of the oscillation amplitudes at these points allows for the determination of diastolic and systolic blood pressure. Empirical studies indicate that these oscillation amplitudes, identified as  $A_d$  for diastolic pressure and  $A_s$  for systolic pressure, are related to the oscillation amplitude  $A_m$ , which corresponds to mean arterial blood pressure. As such, diastolic blood pressure can be identified by first determining the relationship between  $A_d$  and  $A_m$ , which is a fixed constant, and then determining oscillation amplitude  $A_m$ , which is readily identifiable since, by definition, it is the oscillation of maximum amplitude. Systolic blood pressure can be identified in a similar manner.

**[0064]** To illustrate the process described above, consider an example where it is assumed that the relationships between the oscillation amplitudes  $A_m$ ,  $A_d$ , and  $A_s$  may be mathematically represented by the equations:

$$A_d/A_m=X, \text{ and}$$

$$A_s/A_m=Y,$$

where X and Y are constants that are empirically determined based on certain characteristics of the subject, such as shape. Upon determination of oscillation amplitude  $A_m$  through analysis of the pulse waveform signal, one can readily obtain oscillation amplitudes  $A_d$  and  $A_s$ . The points on the pulse waveform signal that correspond to oscillation amplitudes  $A_d$  and  $A_s$  are then identified, by interpolation if necessary. The relationship of  $A_d/A_m$  is a fixed constant value while the relationship of  $A_s/A_m$  may be determined by a linear algorithm. Once these points in time are identified, the corresponding cuff pressures that exist at these two times and which correspond, respectively, to diastolic and systolic blood pressures, are readily determined.

**[0065]** After a blood pressure has been determined through the use of the above algorithm, the steady state signal occurring after the deflation of the bladder will have the characteristics of the calculated blood pressure. The steady state signal (e.g. graph segment **710e**) generated by the sensor assembly after the measurement of mean arterial pressure and deflation of the bladder, may be monitored in a near-continuous manner. The steady state signal generated after the deflation of the bladder is a signature of the measured mean arterial pressure and the calculated blood pressure. Rather than continuously monitoring blood pressure by inflating and deflating the bladder and disturbing the neonate, an envelope may be positioned around waveform signal **710e** and then monitored for one or more predetermined signal characteristics, such as any substantial deviations or fluctuations occurring in the electrical signal that may cross either the lower or upper limit bands of the envelope and indicated an abnormal condition in the neonate. Provided pulse waveform signal **710e** remains in a steady state or near steady state condition, it may be assumed that the previously measured blood pressures levels correlating to the waveform signals **710e** have not substantially changed. If at any time the generated signal from the sensor assembly passes outside of the envelope, control system **600** may be programmed to trigger an alarm to notify

health care professionals of the irregularity and/or perform a new blood pressure measurement and calculation as described above.

[0066] In this manner, an actual blood pressure measurement involving inflation of the bladder and subsequent analysis of the pulse waveform signal **710** occurs only when changes in the waveform signal **710e** indicate probable changes in blood pressure. In this way, continuous monitoring of blood pressure can be maintained without having the intrusive inflating and deflating of the bladder that may disturb the subject.

[0067] In addition to monitoring blood pressure, the sensor assembly may also provide near-continuous monitoring of the pulse or heart rate of the subject. This is accomplished in a manner similar to that previously discussed for providing near-continuous monitoring of blood pressures. Specifically, the sensor assembly is applied to a limb of the subject. If the sensor assembly includes one or more bladders, they should be deflated so as to not constrict the limb, and, consequently, impede blood flow. The light source and the photodetector are energized, generating a pulse waveform signal such as that illustrated in FIG. 12. A similar waveform signal may be generated by a sensor assembly located elsewhere on the subject such as the head. As previously discussed, the pulse waveform signals **700a**, **700b** are indicative of the volumetric changes occurring in the flow of blood through the limb or head. A typical pulse waveform signal **700** will be characterized by a rhythmic pattern of fluctuations or oscillations in the signal. These oscillations represent near-continuous changes in the volumetric blood flow due to the pumping or “beating” action of the heart or cardiac muscle. Consequently, heart rate can be monitored by analyzing the waveform signal and determining the number of oscillations that occur within a predetermined period of time.

[0068] One primary function of blood is to transport oxygen to all tissues that make up the human body. The ability of blood to “carry” oxygen is due to the presence of hemoglobin (Hb) in the red blood cells. Oxygen brought in by the lungs temporarily binds to the hemoglobin (Hb). The oxygenated hemoglobin (HbO<sub>2</sub>) is then transported through the circulatory system, where it releases the oxygen to the cells that need it. Through use of a device known as a pulse oximeter, the oxygen saturation level, defined as the ratio of oxygenated hemoglobin (HbO<sub>2</sub>) to the total amount of hemoglobin (Hb+HbO<sub>2</sub>), can be measured and used to help assess the health of an individual.

[0069] In an embodiment of the invention, control system **600** may be configured to function as a pulse oximeter. In an embodiment, the sensor assembly, may be configured to generate light of two different wavelengths, such as, for example, 650 nanometers (nm) and 805 nm. As illustrated in FIG. 14, hemoglobin (Hb) offers negligible transmission of light having a wavelength of 650 nm, while oxygenated hemoglobin (HbO<sub>2</sub>) readily allows for the transmission of light of 650 nm. In contrast, light having a wavelength of 805 nm transmits equally well through both hemoglobin (Hb) and oxygenated hemoglobin (HbO<sub>2</sub>). Accordingly, the transmission of light at 650 nm indicates a density of oxygenated hemoglobin (HbO<sub>2</sub>), while the transmission of light at 805 nm indicates a density of total hemoglobin (Hb+HbO<sub>2</sub>).

[0070] To measure blood oxygen saturation levels, control unit **600** may be configured to alternately energize the two

light sources of the sensor assembly in rapid succession, e.g., energizing the light sources at 200 pulses per second. In this manner, high-intensity, short duration pulses of first and second wavelengths of light are alternately transmitted through the tissue of limb **200** or head **450**. After passing through the tissue of limb **200** or reflecting through the tissue of head **450**, the alternating streams of light are received by the photodetectors, which, according to this embodiment, is a broadband photodetector capable of detecting both wavelengths. Alternatively, two separate narrow band photodetectors can be used with the sensor assembly, each photodetector capable of detecting light of one wavelength but not light of the other wavelength. The photodetectors convert the two alternating optical signals of different wavelengths into an electric signal representing the transmittance of two wavelengths. Processor **605** then analyzes the signal and determines the optical density for each of the two wavelengths. The ratio of first wavelength to second wavelength optical density is subsequently calculated and scaled to provide an output value corresponding to the percentage of oxygen saturation. As part of this process, the output value generated from the ratio of optical densities can be compared to an appropriate calibration curve programmed into processor **605**, such as, for example, in the form of a lookup table. The calibration curve relates optical density to a suspension, such as blood, and is derived from a variation of Beer's law that relates optical density to the concentration of a dissolved substance.

[0071] It may be advantageous to establish a baseline measurement of the transmittance of the two wavelengths of light before using the sensor assembly to measure blood oxygen saturation levels. In an embodiment of the invention, such a baseline measurement may be readily established if the sensor assembly includes at least one inflatable bladder. Specifically, the bladder may be inflated to a sufficiently high enough pressure so that it constricts the limb or head and drives or squeezes substantially all the blood out of the vessels that run within the portion of the limb or head located in the cuff or beneath the patch. The constriction of the limb or head ensures a lack of blood within the optical path established between the light source and the photodetector. An optical signal passed through these bloodless regions of the limb and head can then be assigned a 100% transmission value.

[0072] To decrease the sensitivity of the sensor assembly systems to stray ambient light, the photodetectors can be synchronously energized with the light sources. This feature ensures that the photodetectors are turned on only when a light source is energized, and minimizes the amount of power drawn by the system, as well as the amount of heat generated by the light sources and photodetectors.

[0073] The present invention may also be configured to monitor the respiration rate of a neonate. Specifically, blood oxygen saturation levels vary subtly with the breathing process, which includes the inspiration of oxygen and expiration of waste gases such as carbon dioxide. Unlike current commercially available pulse oximeters, the sensor assembly possesses short enough response times in its measuring capabilities to detect the subtle rhythmic changes that occur in blood oxygen saturation levels due to the breathing process. An example of this is illustrated in FIG. 15, which depicts an analog recording of the transmittance of the first and second wavelengths of light, such as 650 nm and 805 nm, used to measure blood oxygen saturation levels. Beyond

the relatively high-frequency oscillations **800** that occur in the signals due to the pumping of the cardiac or heart muscle, the more subtle rhythmic variations caused by respiration are readily identified within the signals by the addition of a signal envelope **820**.

[0074] In another embodiment of the present invention, the pulse waveform signal generated by sensor assembly (e.g., cuff **100** or patch **400**) may be analyzed to interpret the performance of the cardio-vascular and pulmonary systems in a human being. FIGS. **16A** and **16B** illustrate a pulse volume waveform signal similar to pulse waveform signal **700a** of FIG. **12A**. The pulse volume waveform signal of FIG. **16A** has been labeled as follows to define areas of interest that are related to the pumping action of the heart:

- [0075] A. Ventricular Contraction
- [0076] B. Ventricular Pressure Rises and Ventricular Volume Increases otherwise known as the QRS Complex
- [0077] C. When ventricular pressure exceeds aortic pressure, the aortic valve opens and blood is ejected into the aorta
- [0078] D. Isovolumetric Relaxation, muscle relaxes, but maintains volume, and pressure reduces
- [0079] E. The rate of volumetric change is shown by the slope of the curve
- [0080] F. Dicrotic Notch is observed and is caused by the closure of the aortic valve
- [0081] G. T-Wave (EKG) ends, ventricular pressure decreases, and volume increases
- [0082] H., I., J. Are the result of Ventricular Systole
- [0083] K., L. Relaxation of the Atrial Chamber provides this signal

Changes in A., B., and C. are understood to be related to the capacity of the heart to contract or “pump performance” while changes in E., F., G., and H. are understood to be related to vascular elasticity. The sampling and envelope technique described above in a previous embodiment may be employed to identify changes in the cardio-vascular and pulmonary systems of a particular human being as illustrated in FIG. **16B**. The changes in the pulse volume waveform with respect to the envelope may be analyzed and interpreted by a health care professional to predict in advance heart disease and other cardio-vascular events that may be related to a heart attack.

[0084] In yet another embodiment of the present invention, the pulse waveform signal generated by the sensor assembly, may be used to produce a Myocardial Contractility Index or “Cardiac Index” and a Tissue Perfusion Index. Myocardial Contractility is the ability of the cardiac muscle to contract. The greater the ability of the cardiac muscle to contract, the greater the cardiac output. Tissue perfusion is related to the volume and flow of blood through the blood vessels. Tissue perfusion is related to ability of body tissues to efficiently exchange waste and nutrients with the blood and is related to the oxygen saturation levels. A cardiac index and a perfusion index may be developed from the pulse waveform signals generated by the sensor assembly.

[0085] FIG. **17** illustrates a pulse volume waveform signal similar to pulse waveform signal **700a** of FIG. **12A**. The microprocessor may be suitably programmed to determine the slope of the curve as well as the area under the curve associated with a single contraction or beat of the heart. This single contraction is represented by a time period from  $t_0$  to  $t_{total}$ . The maximum acceleration, determined by the upward

slope of the curve represents the maximum contractility of the myocardium at a particular heart rate; The change in the slope can be used to develop the Myocardial Contractility Index. Also identified during the single contraction is a point on the curve where the slope of the curve is equal to zero, or  $t_{slope=0}$ . The Tissue Perfusion Index may be represented by the following ratio in determining the area under the curve to the left of  $t_{slope=0}$ :

$$\frac{t_0 - t_{slope=0}}{t_0 - t_{total}}$$

As the heart rate increases or decreases, each of the above ratios may change and the rate of change may correlate to underlying heart disease. A small change in heart rate may cause a drastic change in the amount of oxygen being carried in the blood, which changes the efficiency of body tissues to exchange waste and nutrients with the blood.

[0086] A Vascular Elasticity Index may also be developed from the same curve used to define the Myocardial Contractility Index and the Tissue Perfusion Index. The Vascular Elasticity Index may be represented by the following ratio in determining the area under the curve to the right of  $t_{slope=0}$ :

$$\frac{t_{slope=0} - t_{total}}{t_0 - t_{total}}$$

Vascular elasticity is a measure of the flexibility of blood vessels. As the flexibility of the blood vessels increase or decrease, each of the above ratios may change and the rate of change may correlate to an underlying constriction of the blood vessels leading to heart disease.

[0087] In another embodiment of the present invention, the pulse waveform signal generated from the sensor assembly may be compared to a signal generated from an electrocardiogram (EKG). A traditional EKG is a measurement of the electrical activity of the heart. There may be cases where an EKG may reflect the normal electrical activity of the heart, yet there is no actual pumping of blood from the heart. This is known in the art as electromechanical disassociation. In this particular embodiment, a sensor assembly, such as patch **400** or cuff **100**, may be attached to the skin or implanted within the body near or around a major artery such as the aorta. A signal will be generated by the sensor assembly from the flow of blood through the artery as described in previous embodiments. The signal generated by the sensor assembly measures the actual mechanical pumping of the heart as discussed previously. FIG. **18A** illustrates the electrical activity of the heart, an EKG **900**, and a signal generated by the pumping action of the heart, the pulse waveform signal similar to **700a**. The two signals may be monitored concurrently to identify instances when the electrical activity of the heart, as evidenced by the EKG waveform, is present, yet there is no measurement of tissue perfusion by the sensor assembly, i.e., the heart is not pumping (see FIG. **18B**). This would be evidence of electromechanical disassociation. Electromechanical disassociation, if not recognized, may result in death. Also, both signals may be monitored on a particular person that requires the aid of a pacemaker to ensure that the heart is responding to the signals from the pacemaker.

**[0088]** In yet another embodiment of the present invention, a health care professional may rely on the actual measurements of mean arterial pressure (see FIGS. 13A and 13B), myocardial contractility (see FIG. 17), tissue perfusion (see FIG. 17), and vascular elasticity (see FIG. 17) as defined and discussed above to perform a diagnostic analysis or diagnosis of a person without having to rely on a calculation of the traditional diastolic and systolic blood pressure numbers. The measurements described above are all available signals generated from the sensor assemblies that detect the volume and flow of blood through the vessels. A health care professional may rely on the actual measurements rather than the calculated systolic and diastolic blood pressure numbers to provide a more precise and accurate diagnosis of the pulmonary system of any particular person.

**[0089]** Databases of envelopes may also be created as described in previous embodiments based on the above measurements to develop a number diagnostic indexes such as the cardio index, tissue perfusion index, and vascular elasticity index. These databases may be developed either generically across a population of people based on age, gender, size, etc., or specific to one person based on previous physicals and signal monitoring. The above indexes along with a measurement of mean arterial pressure may be used to quickly, precisely, and accurately diagnose a potentially fatal pulmonary issue if left untreated and more importantly undiscovered.

**[0090]** In another embodiment of the present invention, a sensor assembly, such as patch 400 or similar device may be adapted for use in an effort monitor the physical health of a person on the battlefield or in flight during a war or fighting situation. The embodiments described above to generate pulse waveform signals to monitor vital sign parameters may be employed to continuously or periodically monitor a person's physical health in battle. Rather than being connected directly to control system 600 as described in previous embodiments, radio frequency, ultrasonic, or optical based signals may be employed to transmit signals between an individual soldier and a central command center monitoring all soldiers. Low power devices such as patch 400 may be directly interfaced onto the soldier's outer skin or incorporated into their uniforms or gear.

**[0091]** It will be appreciated from the above description the sensor assemblies of the present invention provides significant advantages over prior art systems and methods by providing the ability to monitor blood parameters, such as blood pressure, heart rate, oxygen saturation and respiration rate, in a near-continuous manner through analysis of a single optical signal. Furthermore; the non-invasive features of the present invention make it an ideal blood parameter monitor for use with neonates. Traditional monitoring devices, such as, for example, auscultatory and prior oscillometric-based methods for monitoring blood pressure, are frequently ineffective with subjects such as neonates due to their relatively small size. In contrast, the sensor assemblies of the present invention are capable of accurately monitoring blood parameters in a relatively small biological entity by transmitting an optical signal through the limb or head of the biological entity. Indeed, the smaller the biological entity, the less tissue the optical signal has to traverse, resulting in a stronger signal that is received by the photodetector and subsequently analyzed to determine vital sign parameters such as, for example, blood pressure.

**[0092]** In the foregoing discussion, the present invention has been drawn to a system and method for monitoring certain vital sign parameters of a neonate by directing an optical signal through the tissue of the neonate's limb or forehead. According to the embodiments discussed up until now, this is accomplished through the use of a cuff-based or patch-based structure that wraps around a limb or is position on a head, or, alternatively, into which a limb is inserted, the cuff and patch structure thereby retaining a light source and photodetector in proximity to the limb and head. However, it is envisioned that the present invention can be implemented in numerous other configurations that would be as equally effective in providing near-continuous monitoring of certain blood parameters of a neonate. For example, according to one additional embodiment of the invention, no such type of cuff structure is utilized. Instead, the light source and photodetector are selectively retained in proximity to the limb through the use of some form of clip or clamping structure that does not encircle the entire limb or, alternatively, through the use of a removable adhesive.

**[0093]** The present invention has been particularly shown and described with reference to the foregoing embodiments, which are merely illustrative of the best modes for carrying out the invention. It should be understood by those skilled in the art that various alternatives to the embodiments of the invention described herein may be employed in practicing the invention without departing from the spirit and scope of the invention as defined in the following claims. It is intended that the following claims define the scope of the invention and that the method and apparatus within the scope of these claims and their equivalents be covered thereby. This description of the invention should be understood to include all novel and non-obvious combinations of elements described herein, and claims may be presented in this or a later application to any novel and non-obvious combination of these elements. Moreover, the foregoing embodiments are illustrative, and no single feature or element is essential to all possible combinations that may be claimed in this or a later application.

1-5. (canceled)

6. An oximetry monitoring system for monitoring a subject's tissue, comprising:

an adhesive forehead sensor comprising a light source and a photodetector in a side-by-side position, the light source emitting light at first and second wavelengths, and the photodetector providing an electrical signal in response to exposure to the light after reflectance by the monitored tissue;

a control system in communication with the photodetector, and equipped to sample the electrical signal and calculate an area under the curve metric responsive to a blood oxygen status of the monitored tissue; and  
a display operated by the control system to provide an indication of the blood oxygen status.

7. The system of claim 6, wherein the light source and the photodetector are carried by a flexible support.

8. The system of claim 7, wherein the flexible support comprises an adhesive patch.

9. The system of claim 6, further comprising an alarm triggered by the control system based on the blood oxygen status.

10. The system of claim 9, wherein the blood oxygen status comprises a measure of oxygen saturation in the monitored tissue.

**11.** The system of claim **6**, wherein the blood oxygen status comprises a measure of tissue perfusion in the monitored tissue.

**12.** The system of claim **6**, wherein the control system comprises an analog to digital converter for sampling the electrical signal, and a processor programmed to calculate the area under the curve metric.

**13.** The system of claim **12**, wherein the processor is further programmed to calculate a tissue perfusion index based on the blood oxygen status over time.

**14.** The system of claim **6**, further comprising a database of reference characteristics, and wherein the control system is further programmed to compare the pulse waveform signal to the reference characteristics.

**15.** An oximetry system, comprising:

a sensor input receiving first and second electrical signals representative of light emitted by first and second emitters, reflected by a subject's tissue, and detected at first and second detectors;

a control system programmed to:

receive the first and second electrical signals and develop a pulse waveform signal representative of a blood parameter;

determine a value of the blood parameter based on the pulse waveform signal;

produce an area under the curve metric based on a pulse of the pulse waveform signal; and

determine a tissue perfusion index based on the area under the curve metric;

a display in communication with the control system; and an alarm triggered by the control system based on a status of the pulse waveform signal.

**16.** The system of claim **15**, further comprising a database of reference characteristics, and wherein the control system is further programmed to compare the pulse waveform signal to the reference characteristics.

**17.** The system of claim **15**, further comprising an adhesive forehead sensor in communication with the sensor input, the adhesive forehead sensor comprising a light source and a photodetector in a side-by-side position, the light source emitting light at first and second wavelengths, and the photodetector providing the first and second electrical signals to the sensor input.

**18.** A method for monitoring vital sign parameters of a subject, comprising:

emitting light from first and second light emitters into a subject's forehead;

detecting the emitted light after reflectance by the subject's forehead, at first and second photodetectors;

generating first and second electrical signals representative of the detected light;

developing a pulse waveform signal based on the electrical signals;

analyzing the pulse waveform signal to produce an area under the curve metric;

monitoring the pulse waveform signal over time; and displaying the pulse waveform signal.

**19.** The method of claim **18**, further comprising determining an oxygen saturation of the subject's tissue based on the first and second electrical signals.

**20.** The method of claim **18**, further comprising triggering an alarm based on a status of the pulse waveform signal.

\* \* \* \* \*

专利名称(译)	非侵入性地监测血液参数		
公开(公告)号	<a href="#">US20170311824A1</a>	公开(公告)日	2017-11-02
申请号	US15/649908	申请日	2017-07-14
[标]申请(专利权)人(译)	柯惠有限合伙公司		
申请(专利权)人(译)	COVIDIEN LP		
当前申请(专利权)人(译)	COVIDIEN LP		
[标]发明人	HENDERSON LESLIE G BAILEY THEODORE M		
发明人	HENDERSON, LESLIE G. BAILEY, THEODORE M.		
IPC分类号	A61B5/024 A61B5/021 A61B5/00 A61B5/1455		
CPC分类号	A61B2560/0412 A61B5/6838 A61B5/6826 A61B5/6824 A61B5/6814 A61B5/14552 A61B5/14551 A61B5/02125 A61B5/021 A61B5/0059 A61B5/02416		
外部链接	<a href="#">Espacenet</a> <a href="#">USPTO</a>		

摘要(译)

公开了一种用于监测生物实体中的生命体征参数的装置。在一个实施例中，该装置包括至少一个用于透射光通过生物实体的光源和至少一个用于接收透过生物实体的光的光电探测器。至少一个光源和至少一个光电探测器被配置成以不显著阻碍血液流过生物实体的方式定位在生物实体附近。响应于光通过生物实体的透射率或反射率而产生信号。该信号对应于通过生物实体的通常无阻碍的血流的至少一个特征。该装置还包括控制系统，该控制系统被配置为分析信号以确定生物实体中的生命体征参数。还提供了一种用于监测生物实体中的生命体征参数的方法。

