



US010271741B2

(12) **United States Patent**  
**Chen et al.**

(10) **Patent No.:** **US 10,271,741 B2**  
(45) **Date of Patent:** **Apr. 30, 2019**

(54) **BIOMETRIC SCALE**

(71) Applicants: **Huami Inc.**, Mountain View, CA (US);  
**Anhui Huami Information Technology Co.,Ltd.**, Hefei (CN)

(72) Inventors: **Ting Chen**, Mountain View, CA (US);  
**Fei Wang**, Mountain View, CA (US);  
**Yajun Zhao**, Hefei (CN); **Jixiang Su**,  
Hefei (CN)

(73) Assignees: **Huami Inc.**, Mountain View, CA (US);  
**Anhui Huami Information Technology Co., Ltd.**, Hefei (CN)

(\* ) Notice: Subject to any disclaimer, the term of this patent is extended or adjusted under 35 U.S.C. 154(b) by 245 days.

(21) Appl. No.: **15/070,737**

(22) Filed: **Mar. 15, 2016**

(65) **Prior Publication Data**

US 2017/0071478 A1 Mar. 16, 2017

**Related U.S. Application Data**

(63) Continuation-in-part of application No. 14/854,569, filed on Sep. 15, 2015.

(51) **Int. Cl.**  
**A61B 5/00** (2006.01)  
**A61B 5/0205** (2006.01)  
(Continued)

(52) **U.S. Cl.**  
CPC ..... **A61B 5/0205** (2013.01); **A61B 5/044** (2013.01); **A61B 5/0408** (2013.01); **A61B 5/117** (2013.01);  
(Continued)

(58) **Field of Classification Search**

USPC ..... 600/508-509; 702/19  
See application file for complete search history.

(56) **References Cited**

U.S. PATENT DOCUMENTS

4,803,625 A 2/1989 Fu et al.  
5,620,003 A 4/1997 Sepponen  
(Continued)

FOREIGN PATENT DOCUMENTS

JP 2006255099 A 9/2006  
WO 2009027556 A2 3/2009

OTHER PUBLICATIONS

Qardiobase Wireless Smart Scale Weight Management Redefined; <https://www.getqardio.com/qardiobase-smart-scale-iphone-android/>; Mar. 15, 2016; 8 pages.

(Continued)

*Primary Examiner* — Nicole F Lavert

*Assistant Examiner* — Nicole F Johnson

(74) *Attorney, Agent, or Firm* — Young Basile Hanlon & MacFarlane, P.C.

(57) **ABSTRACT**

A method for configuring a monitoring component for a user includes receiving an electrocardiograph (ECG) signal from an ECG component, receiving a weight signal from a scale component, and combining features extracted from the ECG signal and the weight signal to generate a current biometric signal. Responsive to the current biometric signal matching a historical biometric signal, the method includes obtaining a user profile and determining a health status for association with the user profile by classifying the current biometric signal using disease models and fitness models.

**21 Claims, 5 Drawing Sheets**

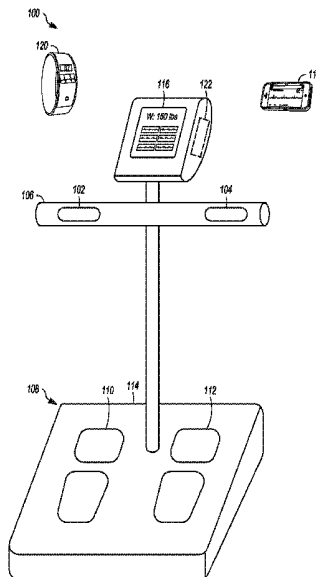

- |      |  |   |
|------|--|---|
| (51) | <b>Int. Cl.</b><br><i>A61B 5/044</i> (2006.01)<br><i>A61B 5/0408</i> (2006.01)<br><i>G01G 19/50</i> (2006.01)<br><i>A61B 5/117</i> (2016.01) | 2013/0157244 A1* 6/2013 Eger ..... G09B 7/00<br>434/350<br>2013/0297219 A1* 11/2013 Bangera ..... G06F 19/345<br>702/19<br>2015/0338265 A1 11/2015 Carreel et al. |
|------|--|---|

- (52) **U.S. Cl.**  
 CPC ..... *A61B 5/6887* (2013.01); *A61B 5/7267*  
 (2013.01); *A61B 5/7475* (2013.01); *G01G*  
*19/50* (2013.01); *A61B 5/726* (2013.01)

OTHER PUBLICATIONS

(56) **References Cited**

U.S. PATENT DOCUMENTS

- |                 |         |                  |
|-----------------|---------|------------------|
| 7,283,870 B2    | 10/2007 | Kaiser et al.    |
| 7,689,833 B2    | 3/2010  | Lange            |
| 9,173,577 B2    | 11/2015 | Yuen et al.      |
| 2002/0151803 A1 | 10/2002 | Kouou            |
| 2007/0021979 A1 | 1/2007  | Cosentino et al. |
| 2008/0221404 A1 | 9/2008  | Tso              |

- Withings Smart Body Analyzer; <http://www.withings.com/us/en/products/smart-body-analyzer>; Mar. 15, 2016; 13 pages.  
 Omron Body Composition Monitor and Scale With Seven Fitness Indicators; <https://omronhealthcare.com/products/body-composition-monitor-scale-seven-indicators-hbf514c/>; Mar. 15, 2016; 4 pages.  
 Ihealth Core Wireless Body Composition Scale; <https://ihealthlabs.com/wireless-scales/ihealth-core/>; Feb. 26, 2016; 3 pages.  
 RD 901 Tanita Innerscan Dual Frequency Body Composition Monitor With Bluetooth 4.0 and Iphone App; <http://tanita.eu/static/rd901.html>; Feb. 26, 2016; 6 pages.  
 Larburu et al. "Comparative study of algorithms for Atrial Fibrillation Detection," *Computing in Cardiology*, 2011; 4 pages.

\* cited by examiner

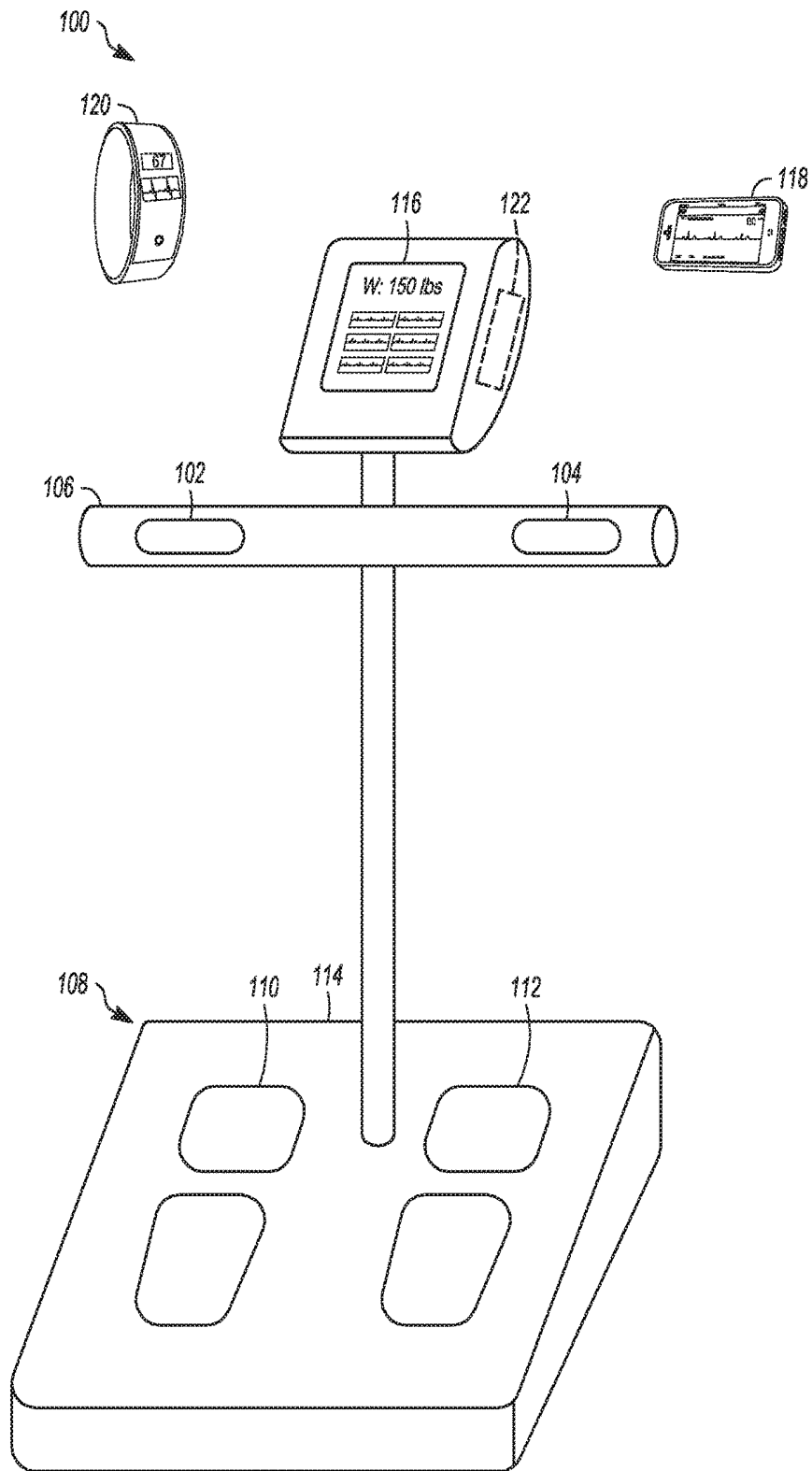

FIG. 1

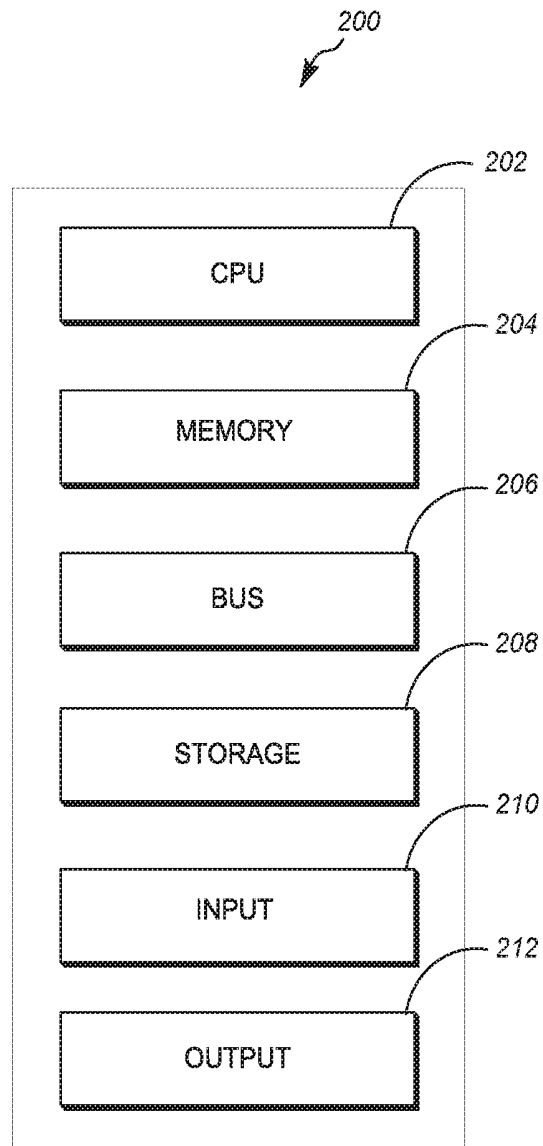

FIG. 2

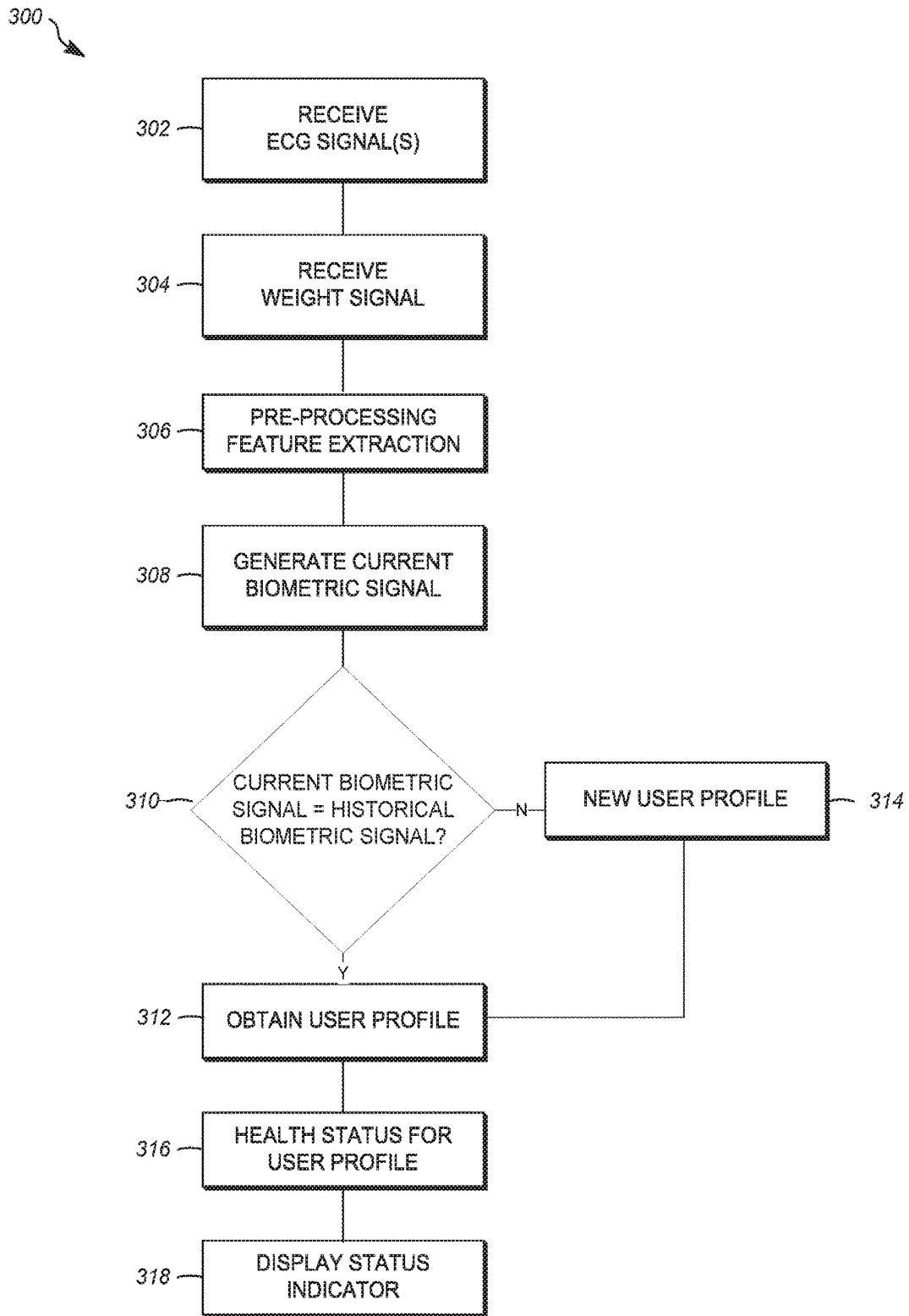

FIG. 3

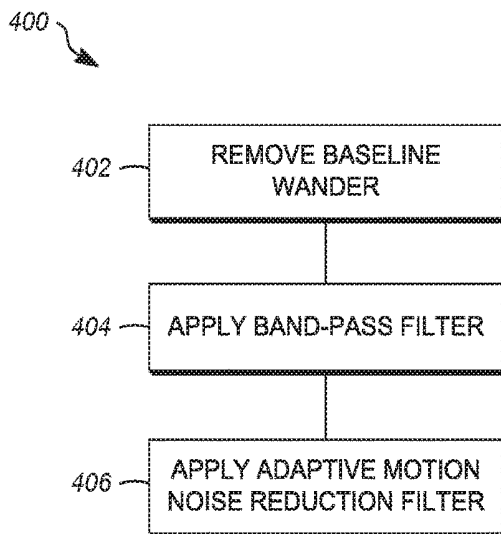

FIG. 4

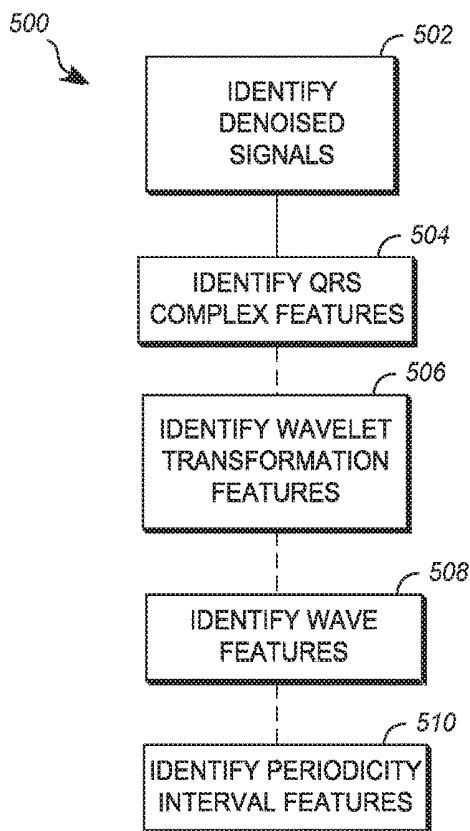

FIG. 5

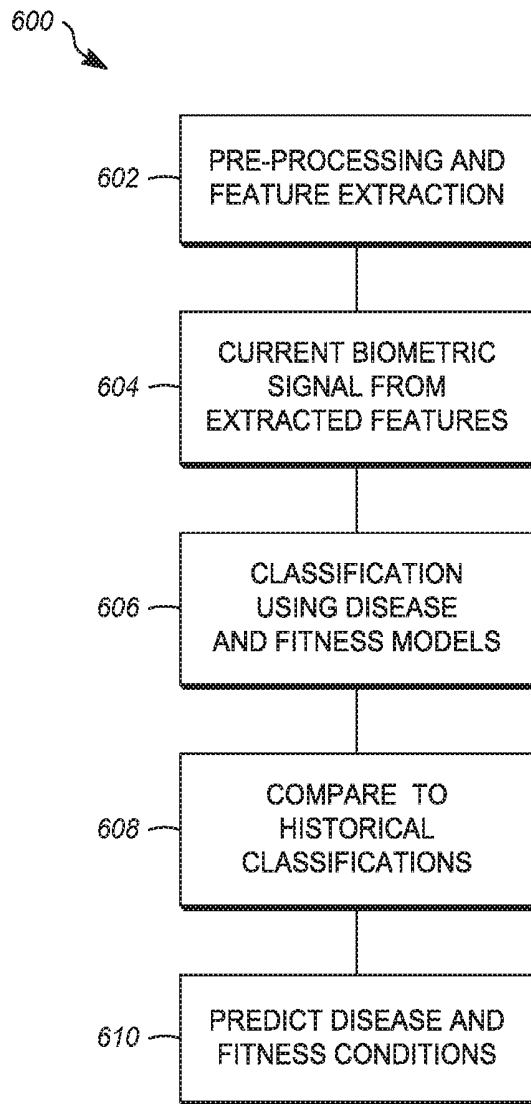

FIG. 6

# 1

## BIOMETRIC SCALE

### CROSS-REFERENCE TO RELATED APPLICATION(S)

This application is a continuation-in-part of U.S. patent application Ser. No. 14/854,569 titled "Wearable Biometric Measurement Device," filed Sep. 15, 2015, and incorporated herein by reference in its entirety.

### TECHNICAL FIELD

This disclosure relates to a monitoring component using both weight and other biometric signals to identify a user and track biometric information associated with the user.

### BACKGROUND

Biometric characteristics have been used to identify unique users for various purposes, including access control. These characteristics conventionally include fingerprints, DNA, retinal maps, facial recognition, etc., the likes of which are secure but expensive identification solutions.

Device users involved in fitness programs or at risk for various diseases may wish not only to be easily identified but also to monitor both weight data and other biometric data, for example, to identify fitness conditions, risk factors, or disease diagnoses. Means currently available to capture weight data and other biometric data are present in separate devices, are overly cumbersome in terms of identification methods, connections, wires, etc., or can offer only a single source for biometric data.

### SUMMARY

Disclosed herein is method for configuring a monitoring component for a user. The method includes receiving an electrocardiograph (ECG) signal from an ECG component, receiving a weight signal from a scale component, and combining features extracted from the ECG signal and the weight signal to generate a current biometric signal. Responsive to the current biometric signal matching a historical biometric signal, the method further includes obtaining a user profile and determining a health status for association with the user profile by classifying the current biometric signal using disease models and fitness models.

Also disclosed herein is a system including an electrocardiogram (ECG) component comprising a first, second, and third electrode wherein a first ECG lead configured to generate a first ECG signal is formed upon user contact with the first and second electrodes and wherein second and third ECG leads configured to generate second and third ECG signals are formed upon user contact with the first, second, and third electrodes. The system further includes a scale component comprising a platform configured to support the user and a weight sensor in communication with the platform and configured to generate a weight signal based on user presence on the platform.

The system also includes a monitoring component comprising a non-transitory memory and a processor configured to execute instructions stored in the non-transitory memory to receive the first, second, or third ECG signal from the ECG component, receive the weight signal from the scale component, and combine features extracted from the first, second, or third ECG signal and the weight signal to generate a current biometric signal. Responsive to the current biometric signal matching a historical biometric signal,

# 2

the monitoring component will obtain a user profile and determine a health status for association with the user profile by classifying the current biometric signal using disease models and fitness models.

Also disclosed herein is a monitoring component including a non-transitory memory and a processor configured to execute instructions stored in the non-transitory memory to receive an electrocardiograph (ECG) signal from an ECG component in contact with a user, receive a weight signal from a scale component in contact with the user, and combine features extracted from the ECG signal and the weight signal to generate a current biometric signal. Responsive to the current biometric signal matching a historical biometric signal, the processor is further configured to obtain a user profile and determine a health status for association with the user profile by classifying the current biometric signal using disease models and fitness models.

Details of these implementations, modifications of these implementations, and additional implementations are described below.

### BRIEF DESCRIPTION OF THE DRAWINGS

The disclosure is best understood from the following detailed description when read in conjunction with the accompanying drawings. It is emphasized that, according to common practice, the various features of the drawings are not to scale. On the contrary, the dimensions of the various features are arbitrarily expanded or reduced for clarity.

FIG. 1 shows a schematic illustration of a monitoring system.

FIG. 2 is a block diagram of a hardware configuration for the monitoring system of FIG. 1.

FIG. 3 is a flow chart showing an example of a process overview of biometric signal matching and health status generation.

FIG. 4 is a flow chart showing an example of a process of pre-processing biometric signals.

FIG. 5 is a flow chart showing an example of a process of feature extraction for biometric signals.

FIG. 6 is a flow chart showing an example of a process of health status determination based on biometric signals.

### DETAILED DESCRIPTION

A monitoring system in the form of a biometric scale captures ECG signals using electrodes and weight signals using a weight sensor for the purposes of both identifying a user and providing a health status to the user. Identification and health status are determined by comparing an analyzed version of the ECG and weight signals in the form of current biometric data to disease models, fitness models, and historical biometric data associated with a user profile. The analysis of the biometric data can occur either directly at the biometric scale or remotely, for example, using a mobile device or a wearable device.

FIG. 1 shows a schematic illustration of a monitoring system **100**. The monitoring system **100** collects biometric data using contact-based communication with a user's hands and feet for purposes of identifying the user and providing a health status to the user.

The monitoring system **100** includes an ECG component that can be selectively trained to identify specific ECG signals from the user, for example, in order to identify stress levels or detect or diagnose specific diseases or disease risk factors. To that end, the ECG component includes first and second electrodes **102** and **104** disposed on a handle **106** that

are configured to measure various aspects of the user's heart function and related biometrics through a touch input or contact with the user's palms and/or fingers when the user grabs the handle **106**. The first and second electrodes **102** and **104** are configured to identify electrical heart activity by measuring the user's pulse and transmitting the ECG signal for subsequent encoding and processing. That is, upon the user contacting both the first electrode **102** and the second electrode **104**, for example, with the palms or fingers of opposite hands, an ECG lead is formed, allowing the monitoring system **100** to measure the user's heart activity. The first and second electrodes **102** and **104** can additionally be configured to collect fingerprints or palm prints from the user for identification purposes.

The monitoring system **100** also includes a base **108** with another ECG component comprising third and, optionally, fourth electrodes **110** and **112** configured to measure various aspects of the user's heart function and related biometrics through contact with the user's feet when the user stands on the base **108** without socks or shoes. When the user contacts both the third electrode **110** of the base **108** while at the same time contacting the first electrode **102** and the second electrodes **104** on the handle **106**, a total of three ECG leads are formed, allowing detection or diagnoses of additional diseases or disease risk factors. For example, the second of the ECG leads is based on voltage between the electrode **104**, generally in contact with the user's right fingers or palm, and the electrode **110**, generally in contact with the user's left foot. The third ECG lead is based on voltage between electrode **102**, generally in contact with the user's left fingers or palm, and the electrode **110**, again, generally in contact with the user's left foot.

The base **108** can also include a scale component. The scale component can include a platform **114** configured to support the user and a weight sensor (not shown) in communication with the platform **114** and configured to generate a weight signal based on user presence on the platform **114**. The weight sensor can be a generally known device comprising load cells, pressure transducers, linear variable differential transformers, capacitance coupled sensors, or strain gages configured to convert the user's physical weight into weight data that is representative of the user's weight.

Though the various electrodes **102**, **104**, **110**, **112** and the weight sensor described above are designed to capture and generate ECG data, weight data, and optionally, fingerprint and palm print data, four types of biometric data, further signal detection components can be included within the monitoring system **100**. For example, the monitoring system **100** can include a thermometer component comprising a temperature sensor (not shown) configured to measure the user's body temperature or a pulse oximeter (not shown) configured to measure the user's blood oxygen level. The various types of biometric data that can be captured and processed by the monitoring system **100** can be useful, for example, in establishing identity of the user and tracking a health status or overall fitness level for the user as described further below.

The monitoring system **100** can also include a display **116** configured to visually represent collected biometric data. In one implementation, the display **116** can be a single output screen for visually representing all collected biometric data. For example, and as shown in FIG. 1, the display **116** includes a single output screen that visually represents both the user's weight in numerical form (e.g., W: 150 lbs.) and the user's heart activity from the first, second, and third ECG leads in graphical form. The information outputted to the

display **116** may be updated as additional biometric data is processed by the monitoring system **100**.

In another implementation, the display **116** may be a plurality of output screens with each output screen visually representing a unique type of collected biometric data. Further, the biometric data captured by the monitoring system **100** can be sent to separate devices for processing or display. For example, in another implementation, weight data and ECG data can be outputted to a user on a display included within a mobile device such as a smart phone **118**. In yet another implementation, weight data and ECG data can be outputted to a user on a display included within a wearable device such as a bracelet **120**. Though a mobile device and a wearable device are given as examples, other devices can also be in communication with the monitoring system **100** to process or display information associated with the biometric data collected using the various electrodes **102**, **104**, **110**, **112** and weight sensors.

The monitoring system **100** can also include a monitoring component in the form of a computing device **122** configured to process and/or transmit biometric data collected by the ECG component and the scale component of the monitoring system **100**. Processing capabilities of the computing device **122** are described further below. The computing device **122** can also be designed to transmit biometric data to separate devices, such as the smart phone **118** or the bracelet **120** for processing and/or display. The computing device **122** can also be designed to transmit biometric data to a medical examiner for review, diagnosis of disease, or other treatment purposes. The computing device **122** can also be designed to transmit biometric data to a database or other related system for storage, such as for later review or comparison in the form of historical biometric data. In one implementation, the computing device **122** includes a Bluetooth transmitter; however, the computing device **122** can communicate with other suitable wireless communication systems, including, without limitation, an ultrasound transmitter.

FIG. 2 is a block diagram of a hardware configuration **200** for the monitoring system **100** of FIG. 1. The hardware configuration **200** can include at least one processor such as central processing unit (CPU) **202**. Alternatively, CPU **202** can be any other type of device, or multiple devices, capable of manipulating or processing information now-existing or hereafter developed. Although the examples herein can be practiced with a single processor as shown, advantages in speed and efficiency can be achieved using more than one processor.

The hardware configuration **200** can include a memory **204** such as a random access memory device (RAM), a read-only memory device (ROM), or any other suitable type of storage device that stores code and data that can be accessed by the CPU **202** using a bus **206**. The code can include an operating system and one or more application programs processing and/or outputting the biometric data for the monitoring system **100**. An application program can include software components in the form of computer executable program instructions that cause the CPU **202** to perform some or all of the operations and methods described herein.

The hardware configuration **200** can optionally include a storage device **208** in the form of any suitable non-transitory computer readable medium, such as a hard disc drive, a memory device, a flash drive or an optical drive. The storage device **208**, when present, can provide additional memory when high processing requirements exist. The storage

device **208** can also store any form of data whether relating to or not relating to biometric data.

The hardware configuration **200** can include one or more input devices **210**, such as a keyboard, a numerical keypad, a mouse, a microphone, a touch screen, a sensor, or a gesture-sensitive input device. Through the input device **210**, data can be input from the user or another device. For example, a gesture-sensitive input device can receive different gestures to switch between different display modes (e.g., heart rate, weight, ECG, etc.). The input device **210** can also be any other type of input device including an input device not requiring user intervention. For example, the input device **210** can be a communication device such as a wireless receiver operating according to any wireless protocol for receiving signals. The input device **210** can also output signals or data, indicative of the inputs, to the CPU **202** using the bus **206**.

The hardware configuration **200** can also include one or more output devices **212**. The output device **212** can be any device transmitting a visual, acoustic, or tactile signal to the user, such as a display, a touch screen, a speaker, an earphone, a light-emitting diode (LED) indicator, or a vibration motor. If the output device **212** is a display, for example, it can be a liquid crystal display (LCD), a cathode-ray tube (CRT), or any other output device capable of providing visible output to the user. In some cases, the output device **212** can also function as an input device **210**, for example, when a touch screen display is configured to receive touch-based input. The output device **212** can alternatively or additionally be formed of a communication device for transmitting signals. For example, the output device **212** can include the computing device **122** described in association with the monitoring system **100** in FIG. 1.

Although FIG. 2 depicts one hardware configuration **200** that can implement the monitoring system **100**, other configurations can be used. The operations of the CPU **202** can be distributed across multiple machines or devices (each machine or device having one or more processors) that can be coupled directly or across a local area or other network. The memory **204** can be distributed across multiple machines or devices such as network-based memory or memory in multiple machines performing operations that can be described herein as being performed using a single computer or computing device for ease of explanation. Although a single bus **206** is depicted, multiple buses can be used. Further, the storage device **208** can be a component of the hardware configuration **200** or can be a shared device that is accessed via a network. Thus, the hardware configuration **200** as depicted in FIG. 2 can be implemented in a wide variety of configurations.

FIG. 3 is a flow chart showing an example of a method **300** of biometric signal matching and health status generation. The operations described in connection with method **300** can be performed using the monitoring component of the monitoring system **100**. The monitoring component can be, for example, the computing device **122**, the smart phone **118**, the bracelet **120**, a remote server (not shown), or the cloud (not shown). The operations described in connection with the method **300** can be embodied as a storage device in the form of a non-transitory computer readable storage medium including program instructions executable by one or more processors that, when executed, cause the one or more processors to perform the operations of the method **300** described below.

At operation **302**, one or more ECG signals are received as captured by a combination of the first, second, third, or fourth electrodes **102**, **104**, **110**, **112** of the ECG component

based on the user gripping the handle **106** and/or standing barefoot on the platform **114** of the monitoring system **100**. At operation **304**, a weight signal is received as captured by the weight sensor of the scale component based on the user standing on the platform **114** of the monitoring system **100**. Other signals can also be captured by other sensors associated with the monitoring system **100**. For example, the user's pulse oxygen level, body temperature, fingerprints, or palm prints can be captured while the user grips the handle **106** and/or stands barefoot on the platform **114**.

Both the ECG signals and the weight signals (as well as any other signals captured) typically comprise raw data and need to be processed in order to be properly used to analyze the user's health, for example, to determine disease diagnoses, stress levels, or readiness for exercise. In one implementation, specific ECG signals may be selectively measured based on training provided by the ECG component of the monitoring system **100**. At operation **306**, the identified ECG and weight signals separately undergo signal pre-processing and feature extraction to determine various features thereof. These processes are described in reference to FIGS. 4 and 5.

FIG. 4 is a flow chart showing an example of a method **400** for pre-processing each of the ECG and weight signals. At sub-operation **402**, a baseline wander, if present, is removed from the ECG and weight signals. At sub-operation **404**, a band-pass filter is applied to the ECG and weight signals in order to remove any undesirable data shifts that occurred while the signals were being measured and to reduce the presence of data outside of a range to be observed (e.g., outliers).

An adaptive motion noise reduction filter is applied at sub-operation **406** that filters identified motion noise included within the ECG and weight signals and reduces the motion noise or entirely removes it to better isolate the important data within those signals. Motion noise may include, for example, fluxes and other changes present in the ECG and weight signals due to the user wiggling or otherwise moving in a manner that may interfere with a clear biometric measurement (e.g., where the user's finger moves on second electrode **104** or the user's foot moves on the third electrode **110** while the ECG signals are being measured). The filter adapts to the specific form of the ECG and weight signals.

FIG. 5 is a flow chart showing an example of a method **500** for performing feature extraction on the biometric signals. Initially, at sub-operation **502**, the denoised signals are identified, as processed and outputted from the preceding sub-operations **402**, **404**, and **406** of the method **400**. At sub-operation **504**, the QRS complex features of the biometric signals are identified to determine the graphical deflections (e.g., wherein Q and S are valleys and R is a peak) representative of the depolarization, for example, of the left and right ventricles of the user's heart. Once the QRS complex features are identified, one or more of three different feature extraction operations may be performed.

At sub-operation **506**, the method **500** can be used to identify wavelet transformation features of the denoised biometric signals. At sub-operation **508**, other wave features, such as wave magnitude features including various fiducial point features relative to the QRS complex features can be identified. At sub-operation **510**, periodicity interval features relative to the QRS complex features and related wave features can be identified. The method **500** can be completed by performing just one of the sub-operations **506**, **508**, **510**, by performing a combination of any two of the

sub-operations **506**, **508**, **510**, or by performing all three sub-operations **506**, **508**, **510**.

The above-described wavelet transformation features determined in sub-operation **506** can be identified along with other frequency domain features (including, without limitation, auto-correlation discrete cosine transform features), which may be identified directly from the processed and denoised biometric signals. That is, in one implementation, the wavelet transformation features and other frequency domain features may be identified separately from the temporal domain features of the biometric signals (e.g., wave magnitude features, periodicity interval features, and other fiducial point features), which temporal domain features are identified, for example, based on the identification and detection of the QRS complex features in sub-operation **504**.

Notwithstanding the foregoing, it is likely that the most accurate results for the method **300** are obtained by performing all three of the sub-operations **506**, **508**, **510**. In one implementation, the extracted features are normalized after they are identified so that the biometric signals may subsequently be compared based on the same periodicity. The extracted features can be used, for example, to detect a specific disease or fitness condition based on certain rules.

Returning to FIG. **3**, at operation **308**, an interrelationship between the various features of the pre-processed ECG and weight signals is determined by checking the features against each other. The extracted features of the ECG and weight signals are then merged into a single current biometric signal for further processing and analysis, which will permit the subsequent operations of the method **300** to yield more accurate results than if the operations were performed separately on the various features of the ECG and weight signals.

At decision-tree **310**, a multi-modal decision fusion can be used to determine whether the identity of the user currently providing input to the monitoring system **100** is known based on a comparison of the current biometric signal generated during the preceding operations to historical biometric signals associated with existing user profiles. Ideally, biometric characteristics are unique in that no two individuals have identical measurements and are permanent in that the characteristics do not change over time.

However, certain types of biometric characteristics, such as measurements identified via ECG signals, may be insufficient when used alone to determine a user's identity, as the measurements may only identify certain qualities of the characteristic, which may be common in many individuals. By using a combination of ECG signals with weight signals, and optionally, other biometric signals based on the user's body temperature, pulse oxygen level, fingerprints, or palm prints, as provided by the user in the form of a current biometric signal, the identification described herein combines different biometric signals from different sensors to more accurately determine the user's identity.

If the current biometric signal matches a historical biometric signal, for example, by comparing the current biometric signal to historical biometric signals stored with user profiles for the monitoring system **100**, the user's identity may be verified, and the method **300** continues to operation **312** where the user's profile is obtained. If the current biometric signal does not match any historical biometric signals, the method **300** continues to operation **314**, and a profile generation request soliciting the user to generate a user profile for the monitoring system **100** is sent to the user. Information related to the profile generation request may be displayed to the user, for example, using the display **116**, the

smart phone **118**, or the bracelet **120**. The user can respond to the profile generation request by providing information to generate a new profile, which in turn can allow the method **300** to proceed to operation **312** where the new user profile is obtained.

At operation **316**, a health status for association with the user profile is determined by machine learning algorithms, such as by classifying the features extracted from the current biometric signal using previously trained disease and fitness models. Disease models allow identification of disease risk factors and/or disease diagnoses for the user based on the current biometric signal. Fitness models allow identification of fatigue levels, stress levels, etc. related to exercise readiness of the user based on the current biometric signal. A more detailed description of how risk factors and disease diagnoses are determined using the current biometric signal is described in reference to FIG. **6**.

FIG. **6** is a flow chart showing an example of a method **600** of disease and fitness prediction. At sub-operation **602**, pre-processing and feature extraction similar to that described above with respect to FIGS. **4** and **5** may be used to refine the ECG and weight signals prior to classifying the same using disease and fitness models. Different disease and fitness models may be used for the classification. For example, if the user is known to have a disease or fitness condition related to the underlying biometric data, for example, heart disease, obesity, or low heart-rate variability, this information can be used in the subsequent analysis, for example, by analyzing the current biometric signal against historical biometric signals collected from the user.

At sub-operation **604**, a current biometric signal is generated using the extracted features of the ECG and weight signals, allowing the subsequent operations of the method **600** to yield more accurate results than if the operations were performed separately on the various features of the ECG and weight signals.

At sub-operation **606**, the current biometric signal is classified using disease and fitness models. This classification determines the likelihood of certain diseases or fitness conditions or the presence thereof. For example, the analysis of the current biometric signal may be used to predict and/or diagnosis the user with obesity, high stress, advanced heart age, low heart rate variability, or other medical conditions such as previous heart attack, congestive heart failure, chronic obstructive pulmonary disease (COPD), anemia, lung cancer, asthma, or pneumonia.

At sub-operation **608**, the classification can be further supported by determining a health status trend by comparing the classification determined using the current biometric signal to classifications determined using historical biometric signals in order to provide further insight for indicating disease factors, fitness factors, or disease diagnoses for the user. For example, if the user has previously been diagnosed with a relevant disease, fitness condition, or medical condition, the comparison between the current classification and the historical classification can be used to identify the user's treatment progress and other developments in treatment.

Based on the results of the analyses, classifications, and comparisons in sub-operations **606** and **608**, an overall prediction of health status for the user, including disease conditions and fitness conditions, can be determined at sub-operation **610**. The health status can include information related to the user's weight, heart rate, fatigue level, stress level, heart age, heart rate variability, or heart condition based on classification of the user's current biometric signal, and optionally, the user's historical biometric signals, using various disease models and fitness models.

Returning to FIG. 3, at operation 318, the method 300 includes displaying a status indicator associated with the health status to the user. The status indicator can be shown to the user, for example, using the display 116, the smart phone 118, or the bracelet 120. Other devices can also provide the status indicator to the user. Non-limiting examples of the content represented by the status indicator can include diagnoses or conditions related to the user's weight, heart rate variability, stress level, heart age, or other various heart diseases such as sinus tachycardia, sinus bradycardia, sinus arrhythmia, sinoatrial exit block, atrial fibrillation, atrial flutter, multifocal atrial tachycardia, wandering atrial pacemaker, ectopic atrial rhythms, atrioventricular nodal reentry tachycardia, premature ventricular contractions, ventricular fibrillation, asystole, junctional rhythms, left anterior fascicular block, etc. After operation 318, the method 300 ends.

While the disclosure has been described in connection with certain embodiments and implementations, it is to be understood that the invention is not to be limited to the disclosed embodiments but, on the contrary, is intended to cover various modifications and equivalent arrangements included within the scope of the appended claims, which scope is to be accorded the broadest interpretation so as to encompass all such modifications and equivalent structures as is permitted under the law.

What is claimed is:

1. A method for configuring a monitoring component for a user, comprising:

receiving an electrocardiograph (ECG) signal of a user from an ECG component;

receiving a weight signal of the user from a scale component in contact with the user;

combining features extracted from the ECG signal and the weight signal to generate a current biometric signal, the current biometric signal used to determine an identity of the user;

responsive to the current biometric signal matching a historical biometric signal stored in a user profile of the user, obtaining the user profile; and

determining a health status for association with the user profile by classifying the current biometric signal using disease models and fitness models.

2. The method of claim 1, further comprising:  
responsive to the current biometric signal not matching a historical biometric signal, sending a profile generation request soliciting the user to generate a user profile.

3. The method of claim 1, wherein receiving the ECG signal comprises receiving a touch input from the user at two or more electrodes associated with the ECG component.

4. The method of claim 1, wherein the health status is related to the user's weight, heart rate, fatigue level, stress level, heart age, heart rate variability, or heart condition.

5. The method of claim 1, wherein determining the health status further comprises classifying the features extracted from the current biometric signal using previously trained models.

6. The method of claim 1, wherein determining the health status further comprises determining a health status trend by comparing the health status determined using the current biometric signal to a health status determined using the historical biometric signal.

7. The method of claim 1, further comprising:  
displaying, at an output screen associated with the monitoring component, a status indicator associated with the health status.

8. The method of claim 1, wherein the ECG component comprises:

a first electrode; and

a second electrode;

wherein the ECG signal is generated upon user contact with the first and second electrodes.

9. The method of claim 1, wherein the scale component comprises:

a platform configured to support the user; and

a weight sensor in communication with the platform and configured to generate the weight signal based on user presence on the platform.

10. A monitoring component, comprising:

a non-transitory memory; and

a processor configured to execute instructions stored in the non-transitory memory to:

receive an electrocardiograph (ECG) signal from an ECG component in contact with a user;

receive a weight signal from a scale component in contact with the user;

combine features extracted from the ECG signal and the weight signal to generate a current biometric signal, the current biometric signal used to determine an identity of the user;

responsive to the current biometric signal matching a historical biometric signal stored in a user profile of the user, obtain the user profile; and

determine a health status for association with the user profile by classifying the current biometric signal using disease models and fitness models.

11. The apparatus of claim 10, wherein the processor is further configured to:

responsive to the current biometric signal not matching a historical biometric signal, send a profile generation request soliciting the user to generate a user profile.

12. The apparatus of claim 10, wherein receiving the ECG signal comprises receiving a touch input from the user at two or more electrodes associated with the ECG component.

13. The apparatus of claim 10, wherein the health status is related to the user's weight, heart rate, fatigue level, stress level, heart age, heart rate variability, or heart condition.

14. The apparatus of claim 10, wherein determining the health status further comprises determining a health status trend by comparing the health status determined using the current biometric signal to a health status determined using the historical biometric signal to.

15. The apparatus of claim 10, wherein the processor is further configured to:

display, at an output screen associated with the monitoring component, a status indicator associated with the health status.

16. A non-transitory computer-readable medium storing a set of instructions for configuring a monitoring component for a user, which when executed by a computer system using a processor become operational with the processor for configuring the monitoring component, the set of instructions comprising instructions to:

receive an electrocardiograph (ECG) signal from an ECG component in contact with a user;

receive a weight signal from a scale component in contact with the user;

combine features extracted from the ECG signal and the weight signal to generate a current biometric signal, the current biometric signal used to determine an identity of the user;

responsive to the current biometric signal matching a historical biometric signal stored in a user profile of the user, obtain the user profile; and determine a health status for association with the user profile by classifying the current biometric signal using disease models and fitness models. 5

17. The non-transitory computer-readable medium of claim 16, wherein the set of instructions further comprises instructions to:

responsive to the current biometric signal not matching a historical biometric signal, send a profile generation request soliciting the user to generate a user profile. 10

18. The non-transitory computer-readable medium of claim 16, wherein receiving the ECG signal comprises receiving a touch input from the user at two or more electrodes associated with the ECG component. 15

19. The non-transitory computer-readable medium of claim 16, wherein the health status is related to the user's weight, heart rate, fatigue level, stress level, heart age, heart rate variability, or heart condition. 20

20. The non-transitory computer-readable medium of claim 16, wherein determining the health status further comprises determining a health status trend by comparing the health status determined using the current biometric signal to a health status determined using the historical biometric signal to. 25

21. The non-transitory computer-readable medium of claim 16, wherein the set of instructions further comprises instructions to:

display, at an output screen associated with the monitoring component, a status indicator associated with the health status. 30

\* \* \* \* \*

专利名称(译)	生物识别量表		
公开(公告)号	<a href="#">US10271741</a>	公开(公告)日	2019-04-30
申请号	US15/070737	申请日	2016-03-15
[标]申请(专利权)人(译)	华密公司 安徽华米信息科技有限公司		
申请(专利权)人(译)	HUAMI INC. 安徽HUAMI信息技术有限公司.		
当前申请(专利权)人(译)	HUAMI INC. 安徽HUAMI信息技术有限公司.		
[标]发明人	CHEN TING WANG FEI ZHAO YAJUN SU JIXIANG		
发明人	CHEN, TING WANG, FEI ZHAO, YAJUN SU, JIXIANG		
IPC分类号	A61B5/00 A61B5/117 A61B5/0408 A61B5/044 G01G19/50 A61B5/0205		
CPC分类号	G01G19/50 A61B5/6887 A61B5/0205 A61B5/044 A61B5/0408 A61B5/117 A61B5/7267 A61B5/7475 A61B5/726		
其他公开文献	US20170071478A1		
外部链接	<a href="#">Espacenet</a>		

摘要(译)

一种用于为用户配置监视组件的方法包括：从ECG组件接收心电图（ECG）信号，从比例组件接收权重信号，以及组合从ECG信号和权重信号中提取的特征以生成当前生物信号。响应于与历史生物计量信号匹配的当前生物计量信号，该方法包括通过使用疾病模型和健康模型对当前生物计量信号进行分类来获得用户简档并确定与用户简档相关联的健康状态。

