



US 20190286233A1

(19) **United States**

(12) **Patent Application Publication**  
**Newberry**

(10) **Pub. No.: US 2019/0286233 A1**

(43) **Pub. Date: Sep. 19, 2019**

(54) **SYSTEM AND METHOD FOR MOTION  
DETECTION USING A PPG SENSOR**

*G06K 9/00* (2006.01)

*A61B 5/00* (2006.01)

*A61B 5/0488* (2006.01)

(71) Applicant: **Sanmina Corporation**, San Jose, CA  
(US)

(52) **U.S. Cl.**

CPC ..... *G06F 3/014* (2013.01); *G06F 3/015*

(2013.01); *G06F 3/017* (2013.01); *G06F*

*3/0304* (2013.01); *G06K 9/00355* (2013.01);

*G06F 1/163* (2013.01); *A61B 5/0488*

(2013.01); *A61B 5/6825* (2013.01); *A61B*

*5/7475* (2013.01); *A61B 5/0075* (2013.01);

*A61B 5/725* (2013.01)

(72) Inventor: **Robert Newberry**, New Hope, AL  
(US)

(21) Appl. No.: **16/103,876**

(22) Filed: **Aug. 14, 2018**

**Related U.S. Application Data**

(60) Provisional application No. 62/675,151, filed on May 22, 2018, provisional application No. 62/643,643, filed on Mar. 15, 2018.

**Publication Classification**

(51) **Int. Cl.**

*G06F 3/01* (2006.01)

*G06F 3/03* (2006.01)

(57)

**ABSTRACT**

A photoplethysmography (PPG) circuit obtains PPG signals at one or more wavelengths. The PPG signal is processed to identify motion artifacts. The motion artifacts are correlated with predetermined PPG signal patterns associated with a movement of a body part. The PPG signals may thus be used to detect movement of the body part. A user device may be controlled in response to the detected movement of the body part.

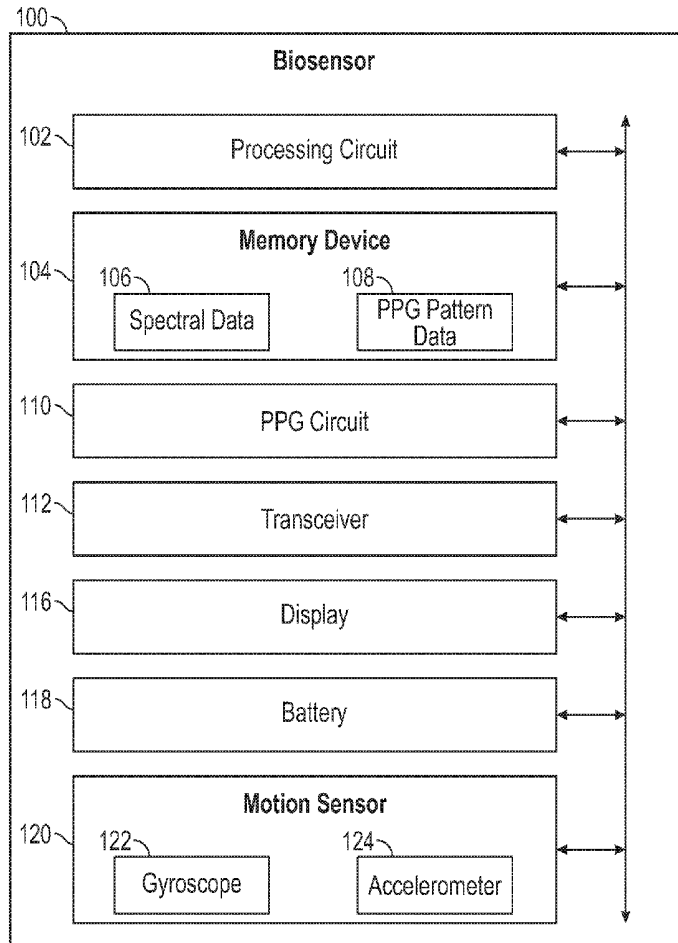

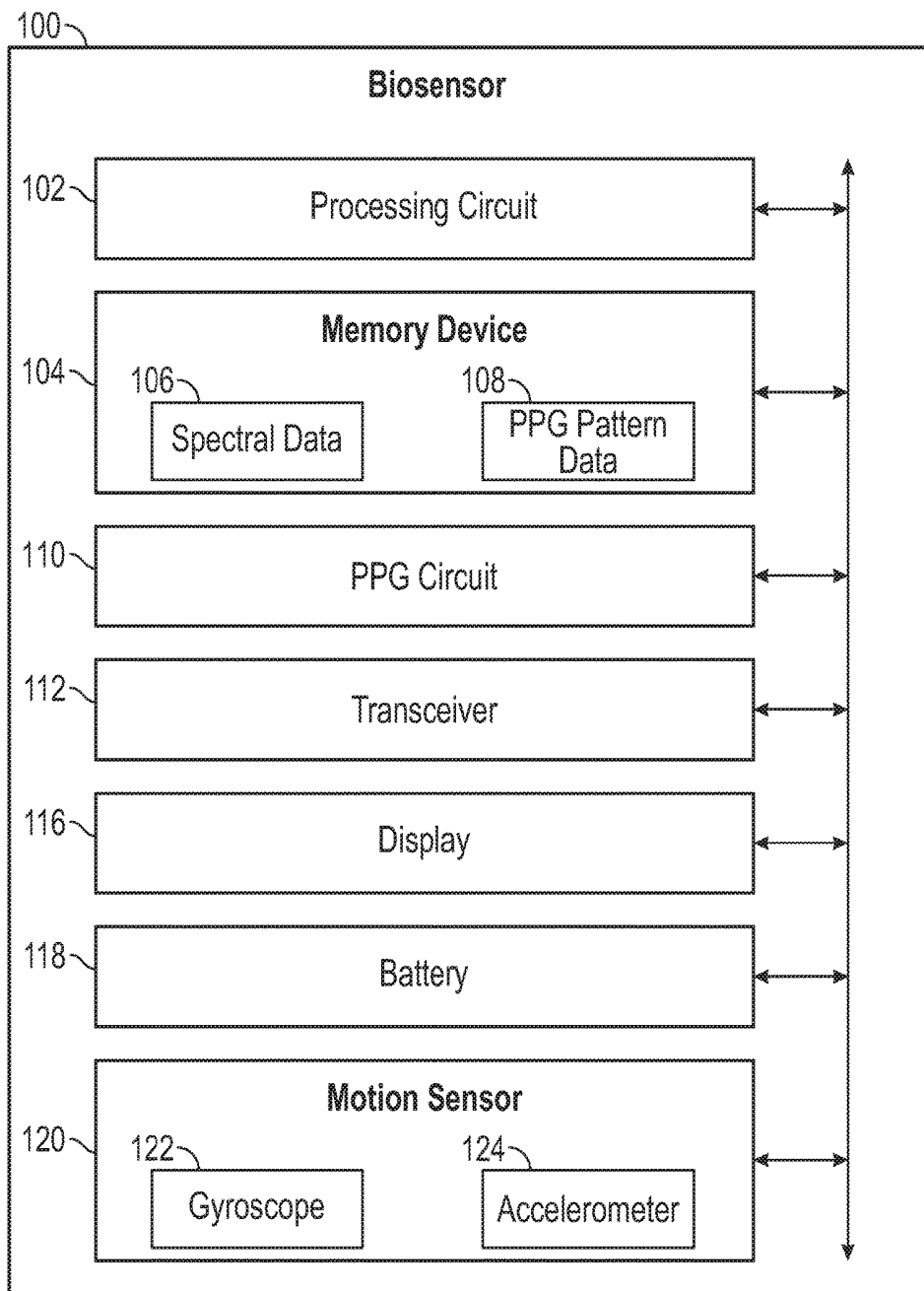

FIG. 1

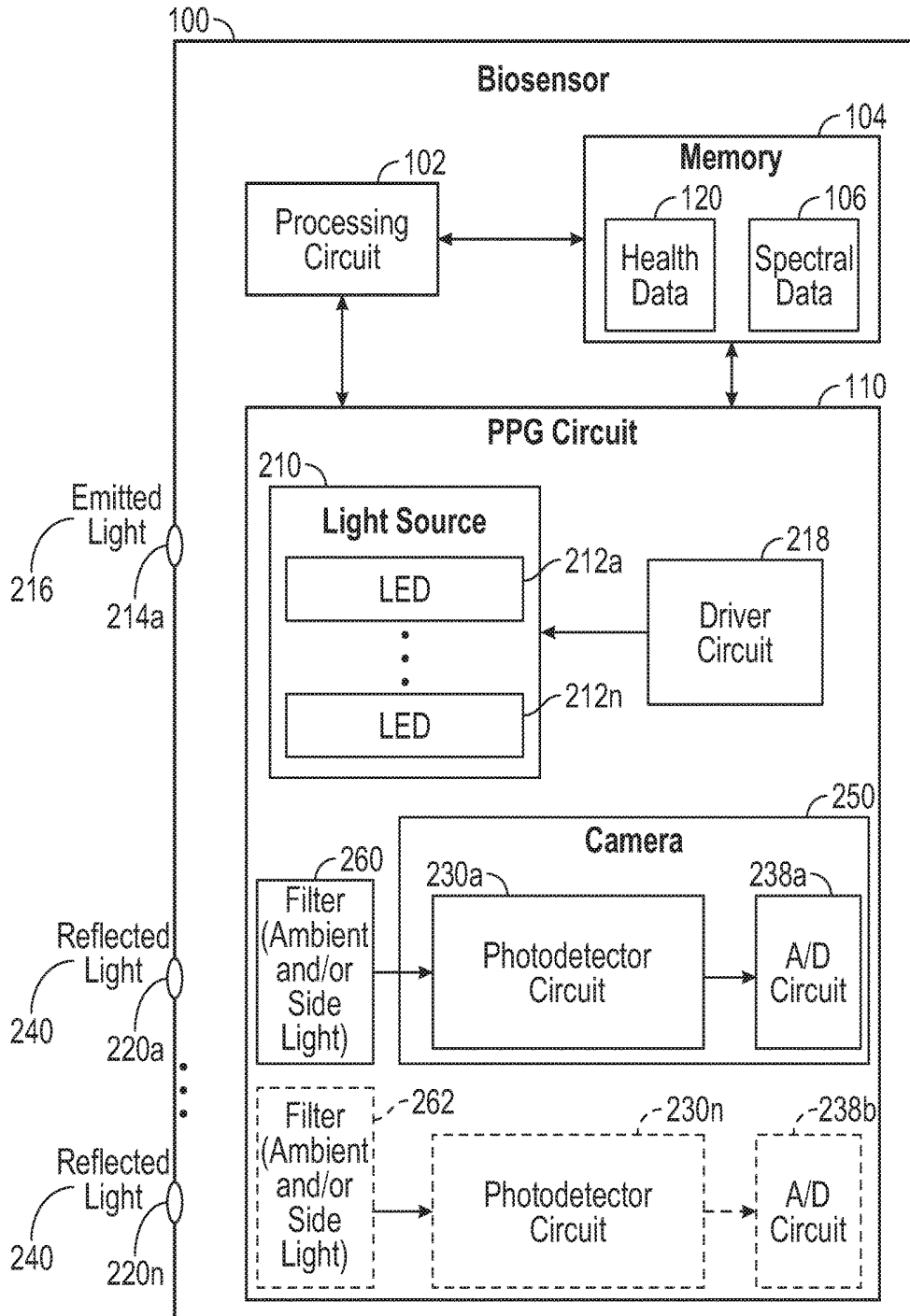

FIG. 2

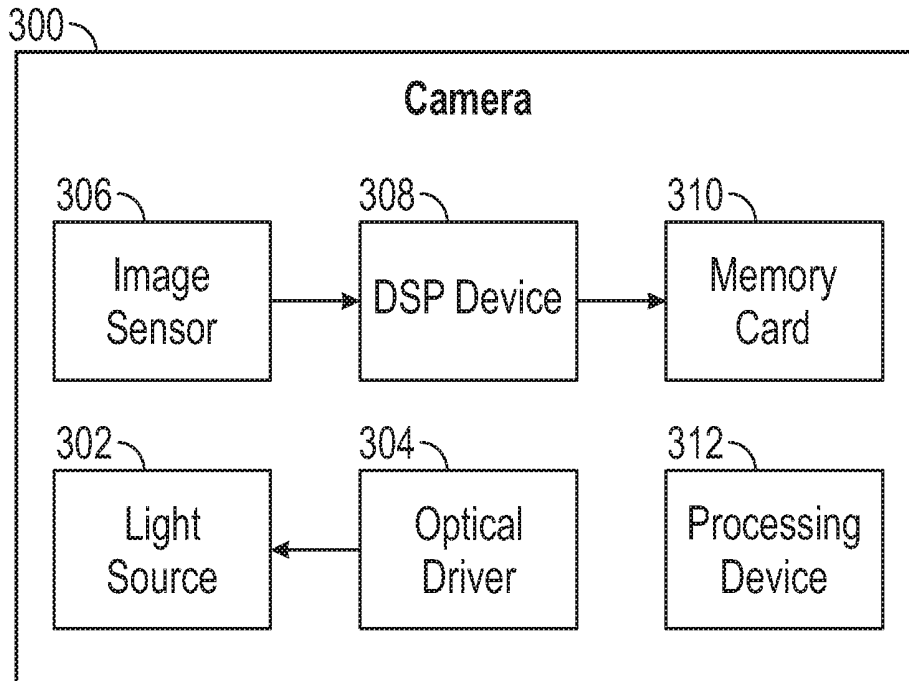

FIG. 3

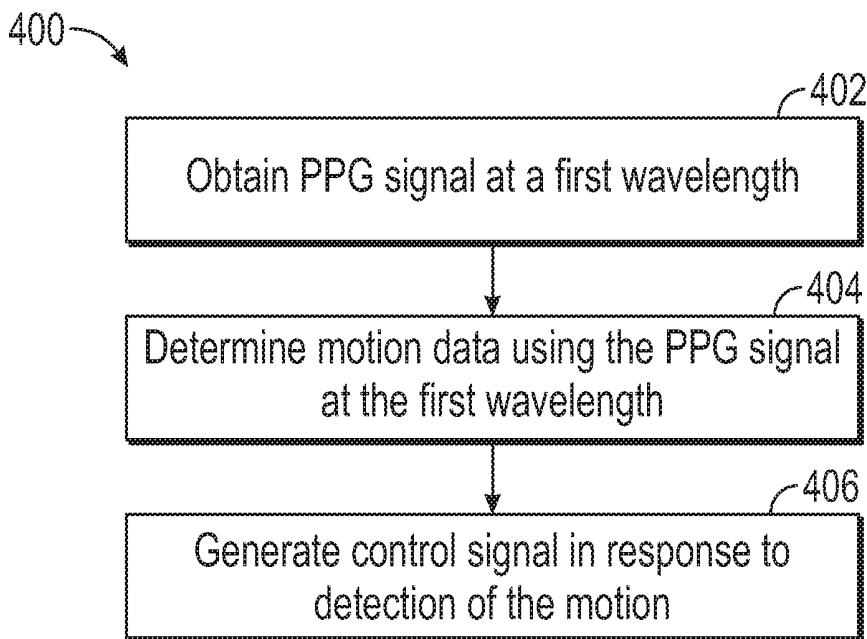

FIG. 4

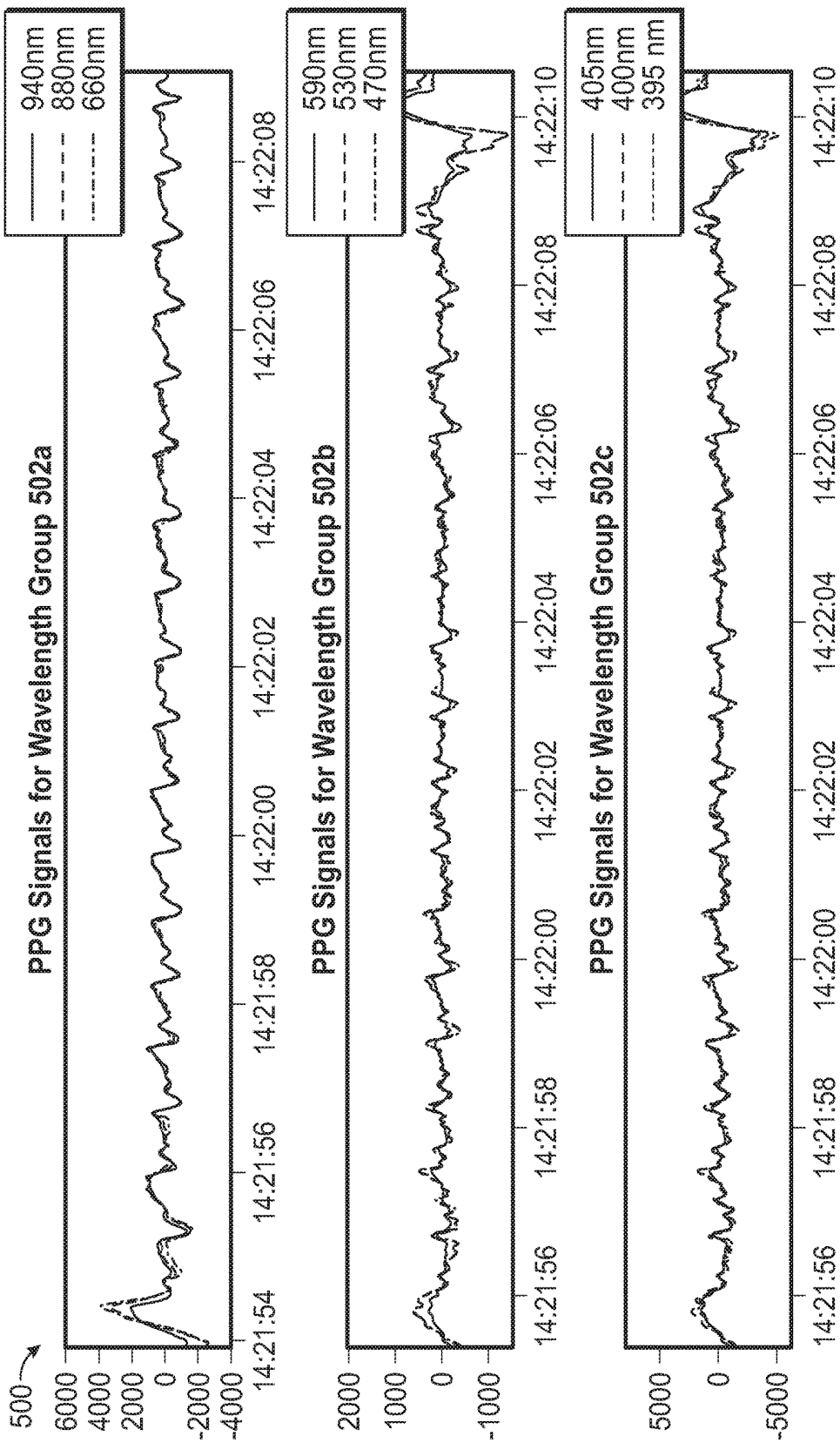

FIG. 5

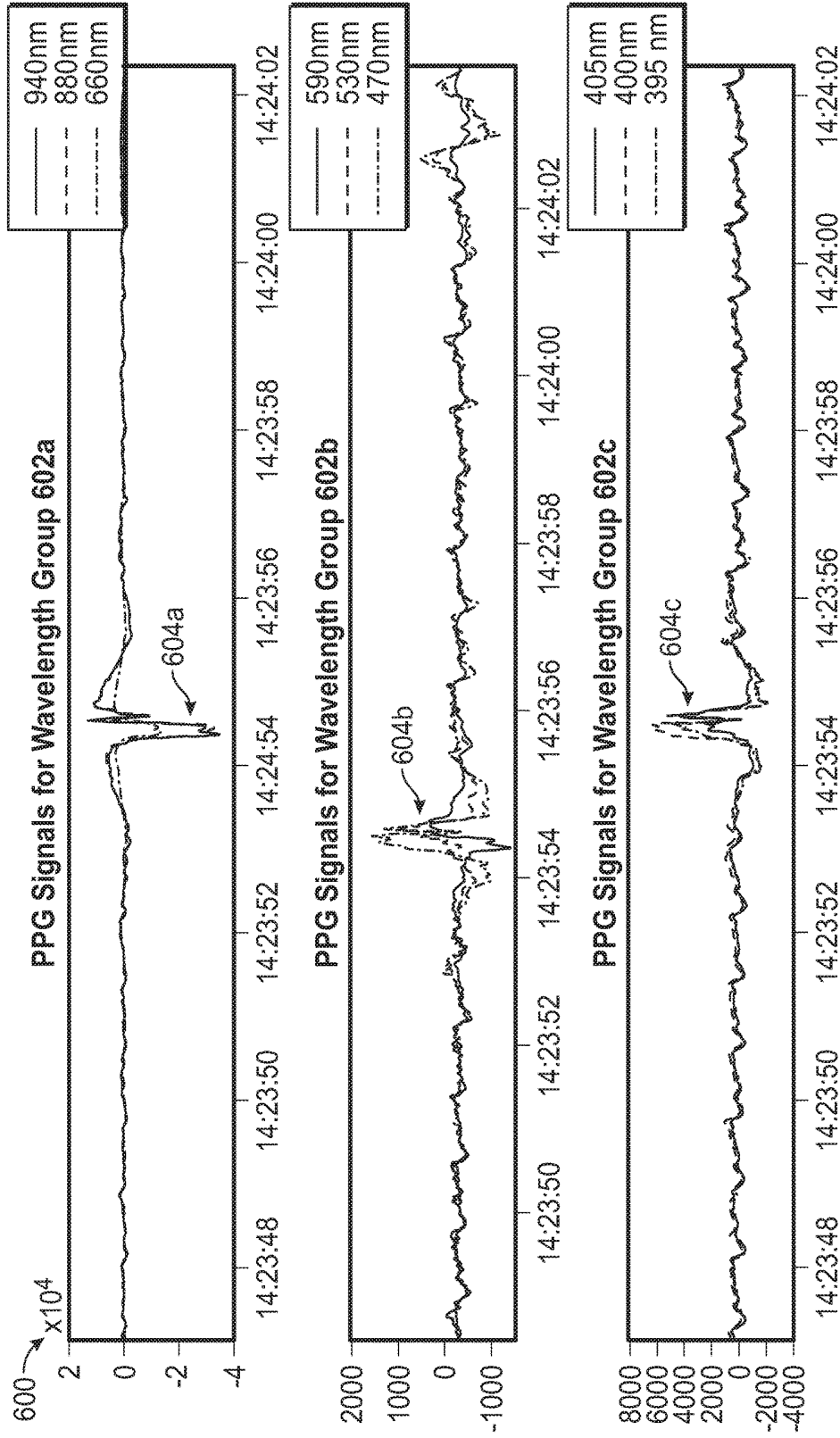

FIG. 6

Movement of Thumb

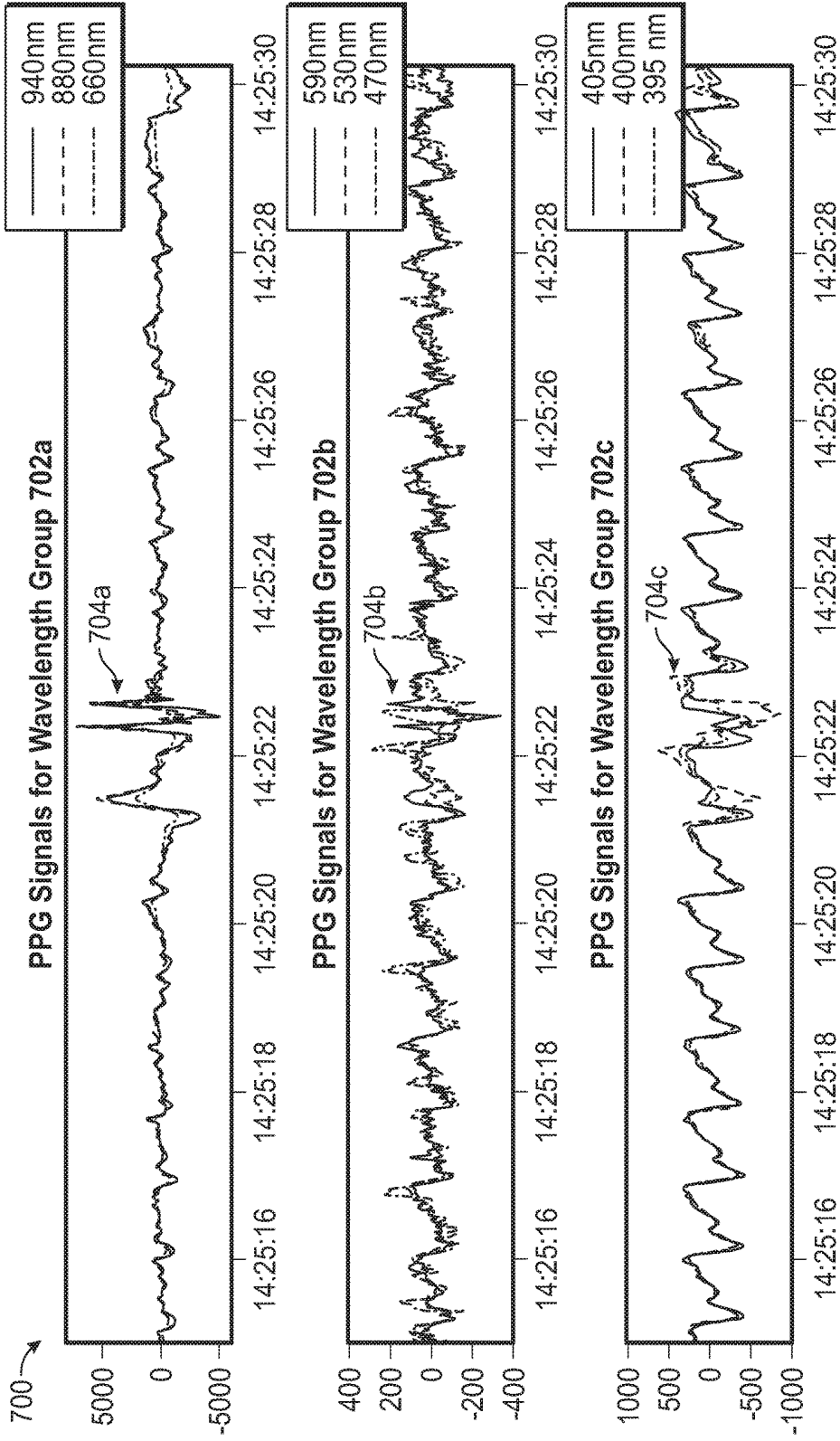

FIG. 7

Movement of Index Finger

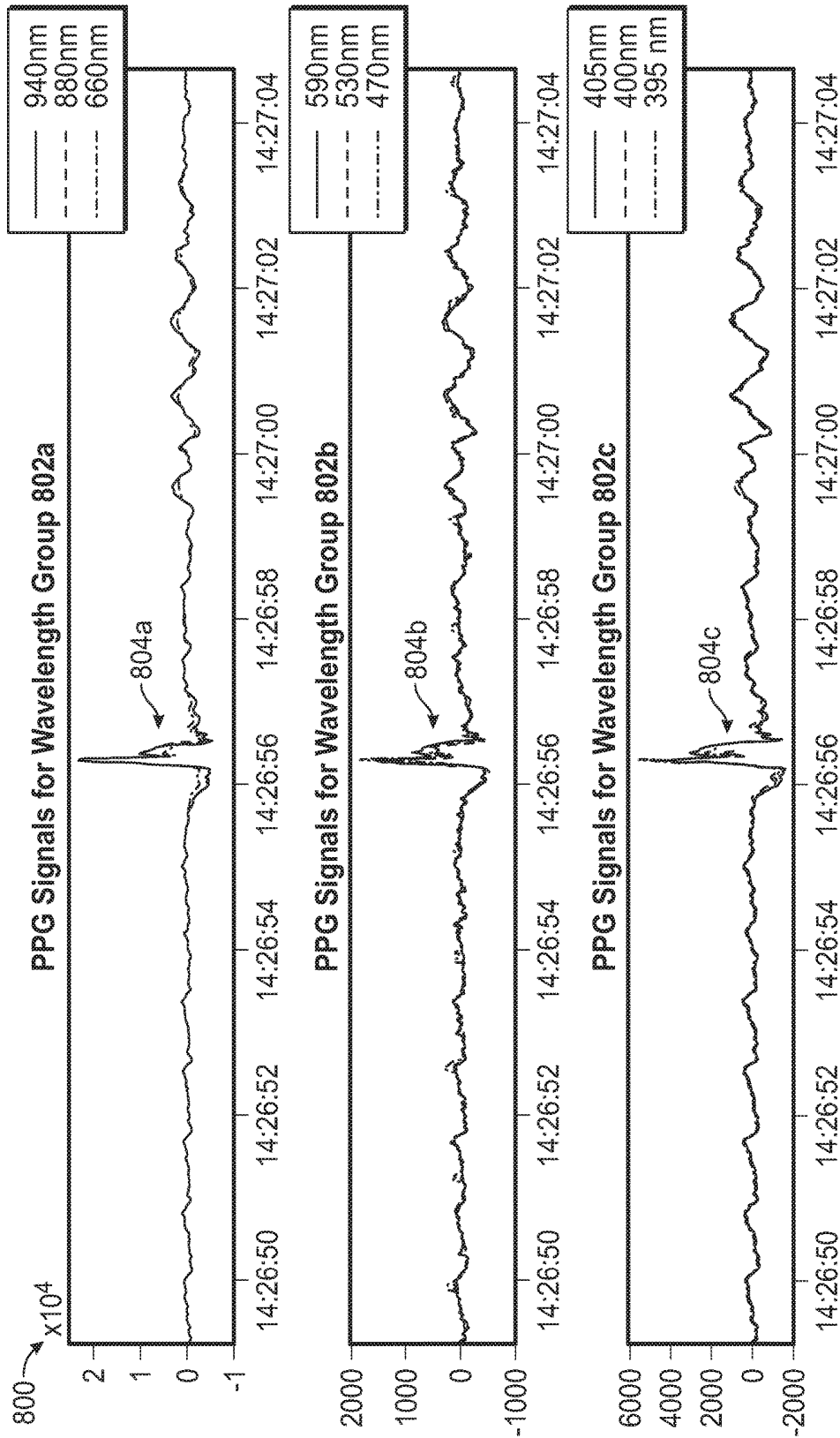
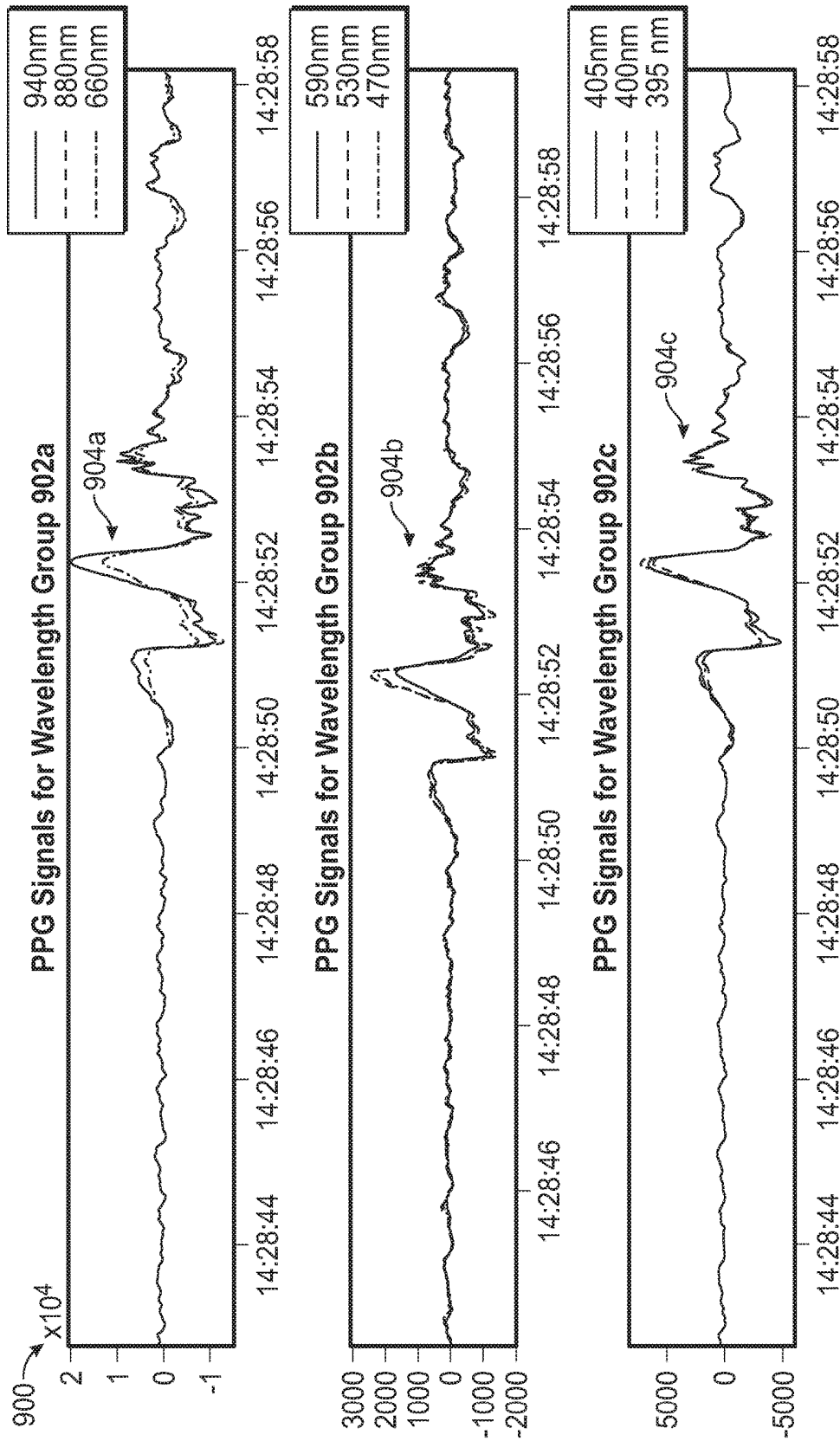

FIG. 8

Movement of Middle Finger



Movement of 4th Finger **FIG. 9**

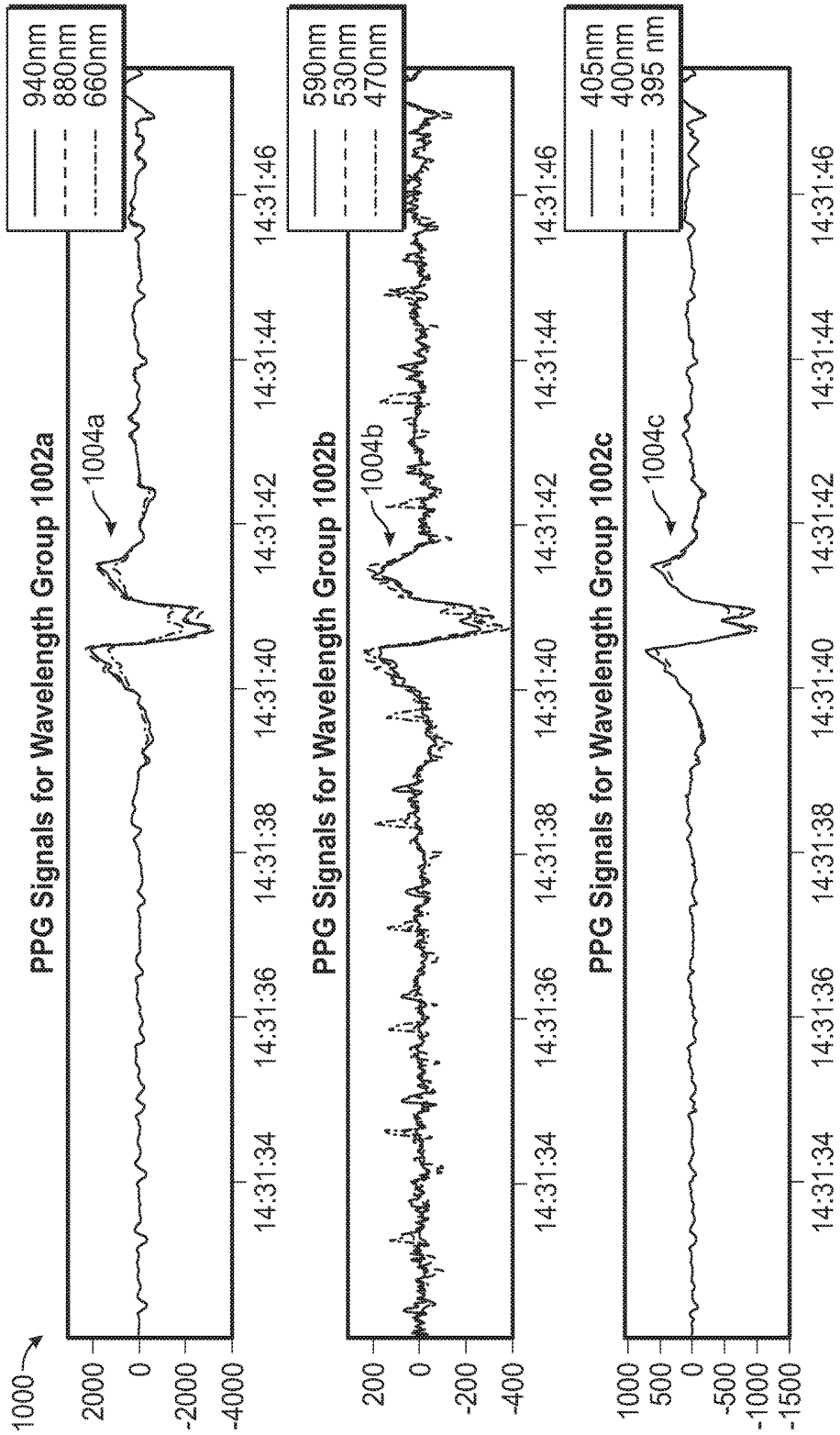

FIG. 10

Movement of 5th Finger

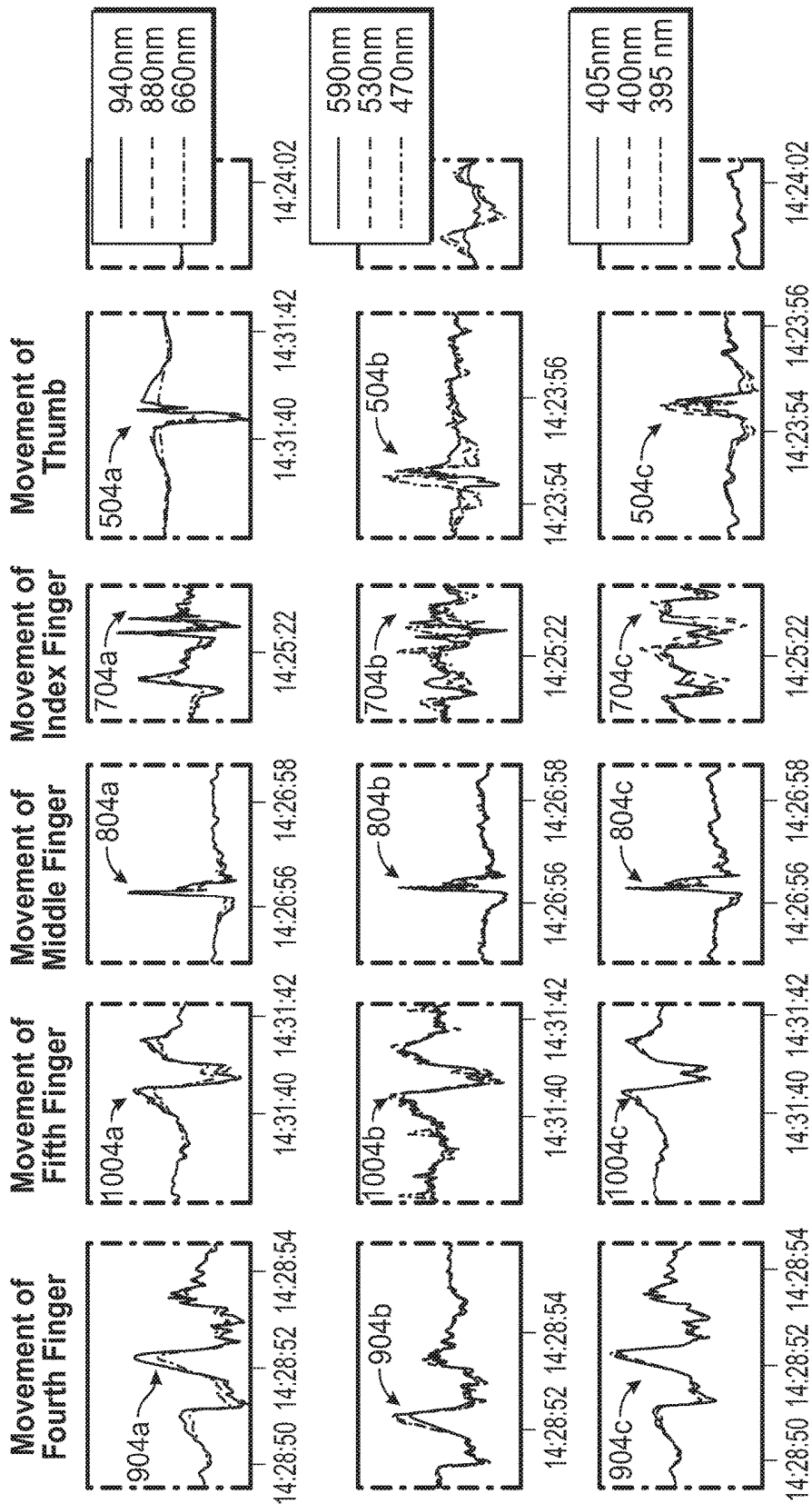

FIG. 11

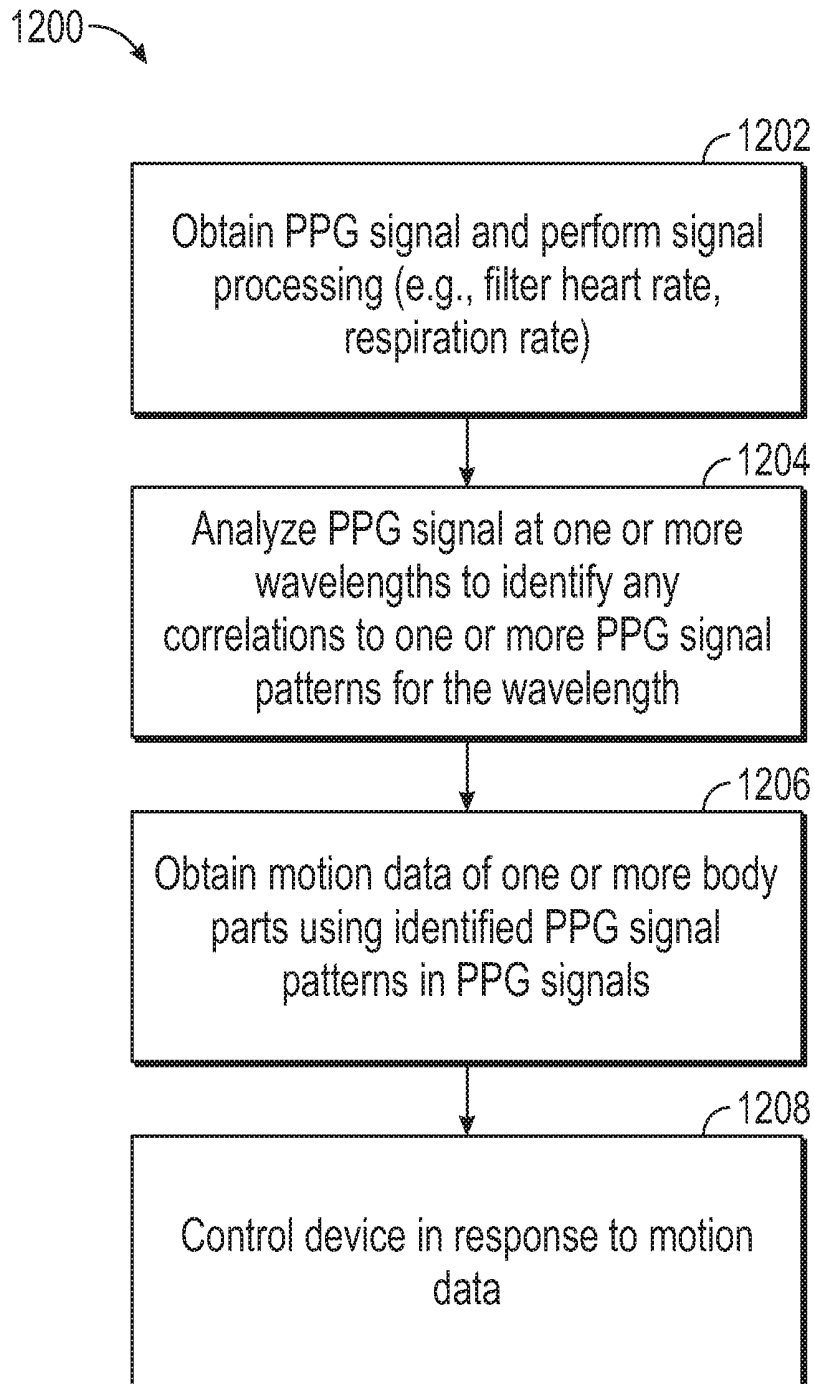

FIG. 12

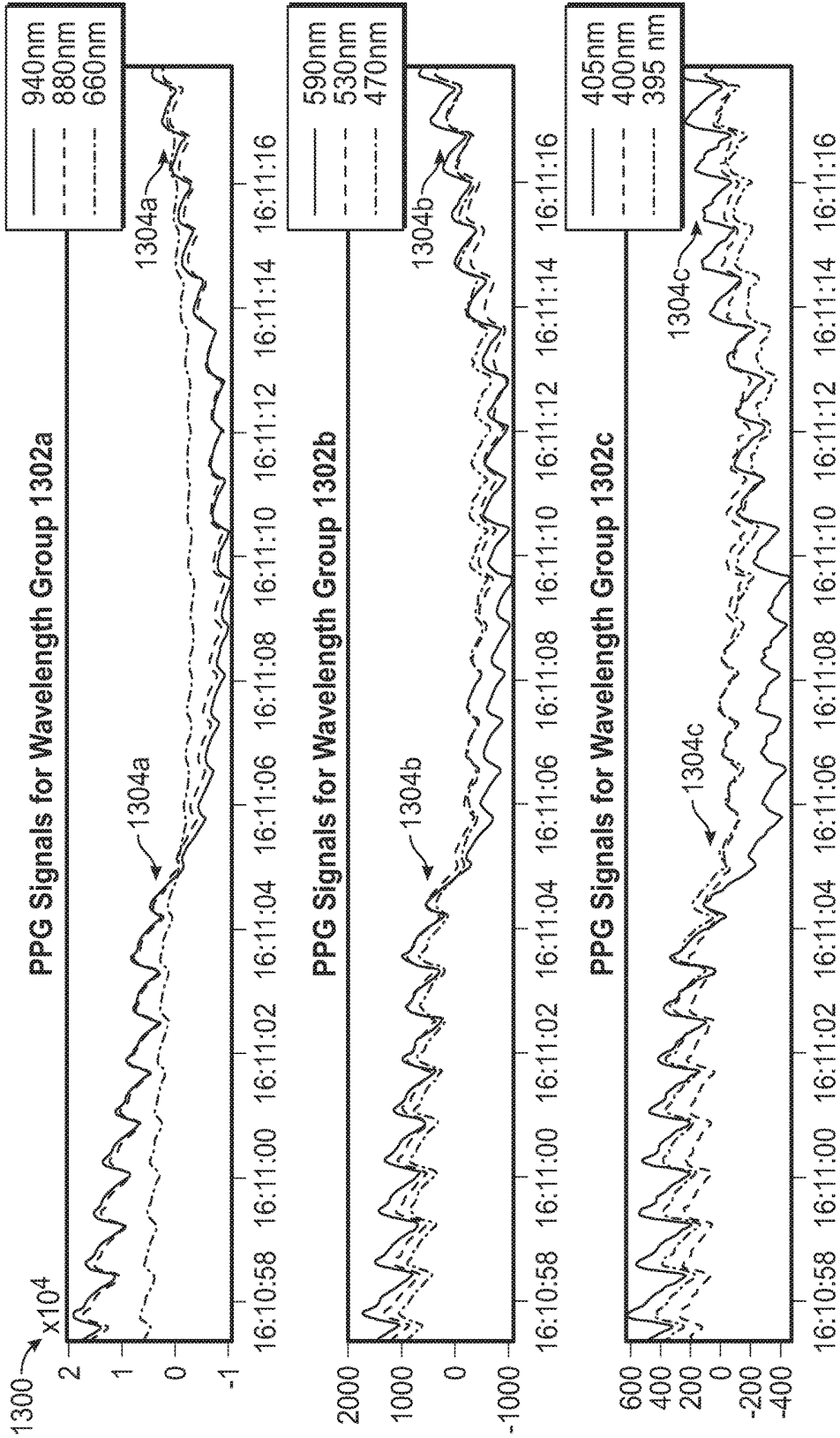

FIG. 13

Example of Vasodilation Measurement Using PPG Signals After Caloric Intake

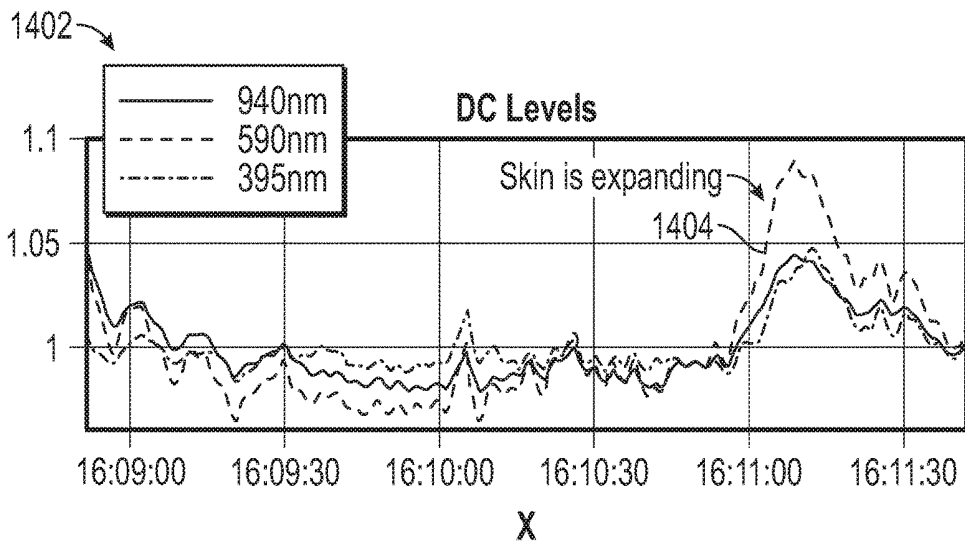
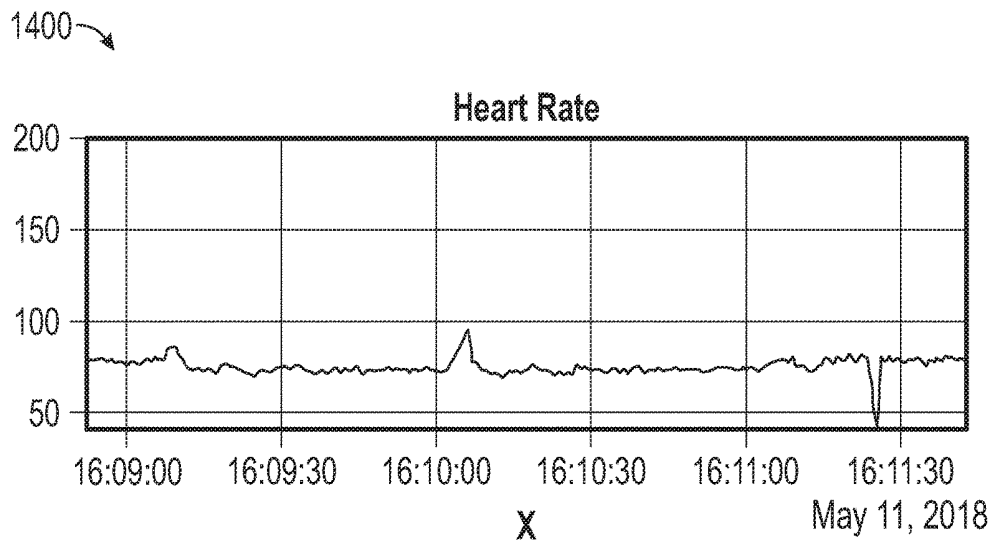

FIG. 14

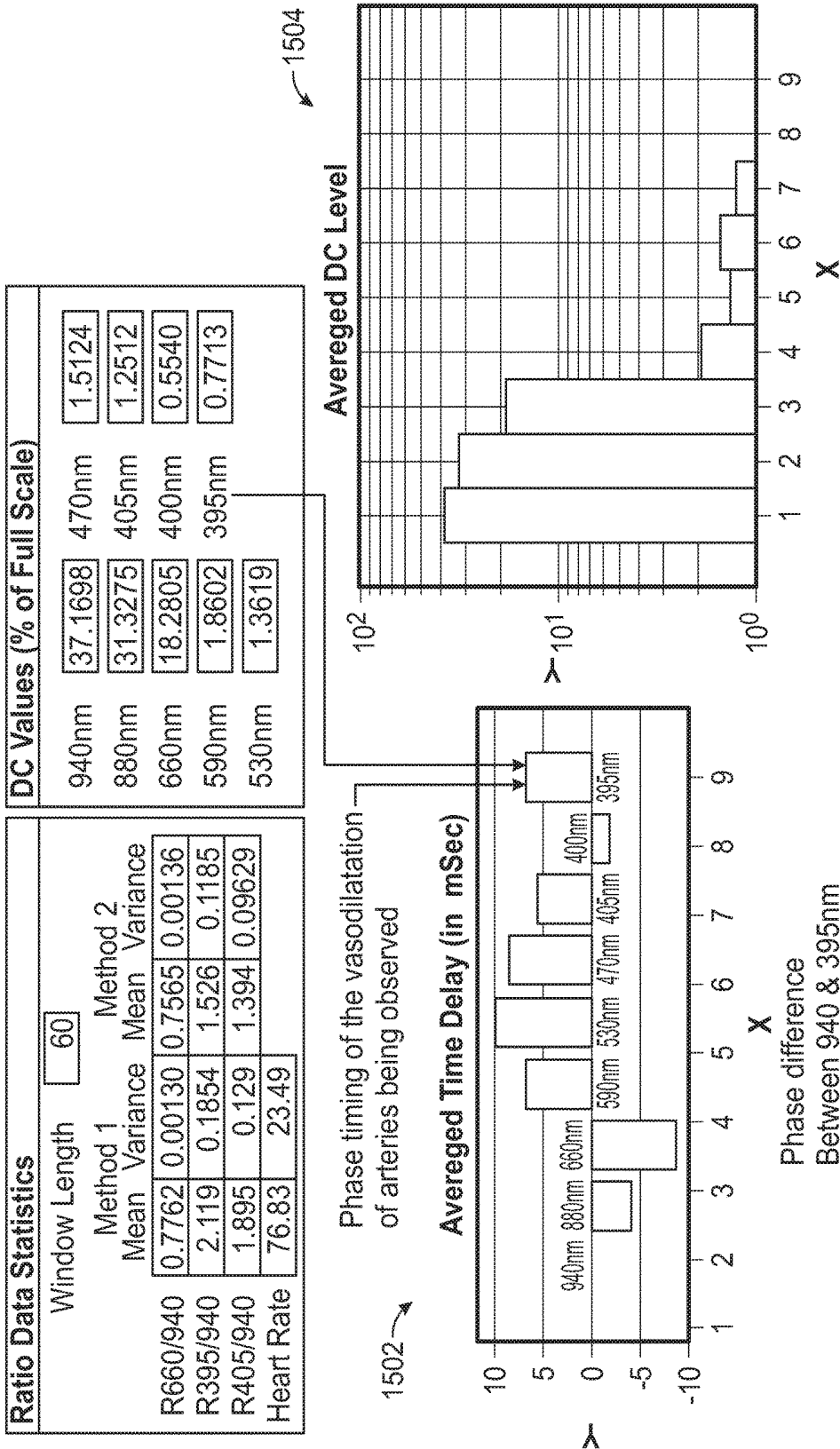

FIG. 15A

Ratio Data Statistics				
Window Length	60			
Method 1	Method 2			
Mean	Mean			
Variance	Variance			
R660/940	0.7714	0.00236	0.7525	0.00106
R395/940	1.788	0.2584	1.539	0.09232
R405/940	1.646	0.2235	1.384	0.06987
Heart Rate	76.03	8.815		

DC Values (% of Full Scale)			
940nm	37.0099	470nm	1.5267
880nm	31.0974	405nm	1.2405
660nm	18.1471	400nm	0.5473
590nm	1.8564	395nm	0.7545
530nm	1.3543		

1508

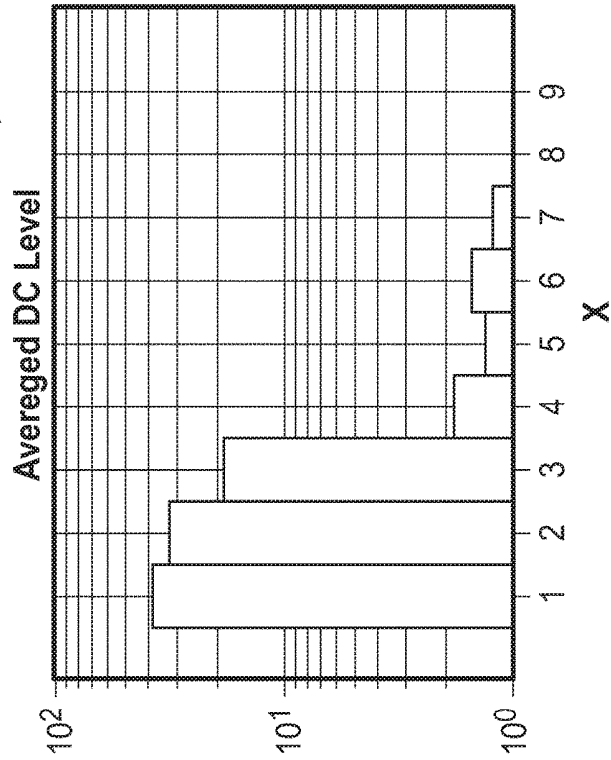

1506

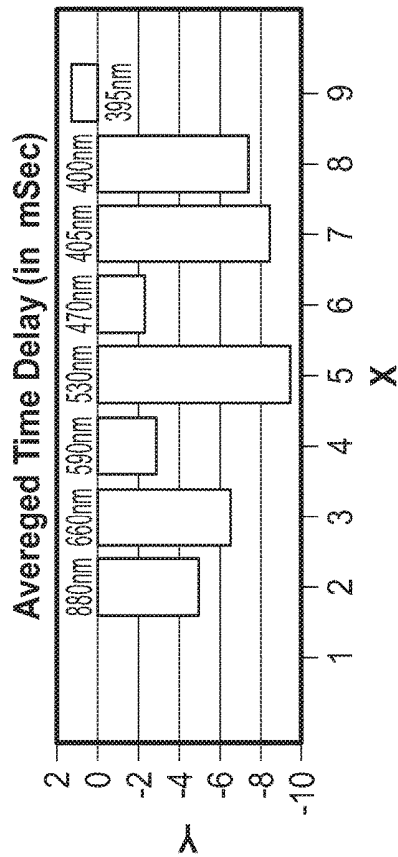

FIG. 15B

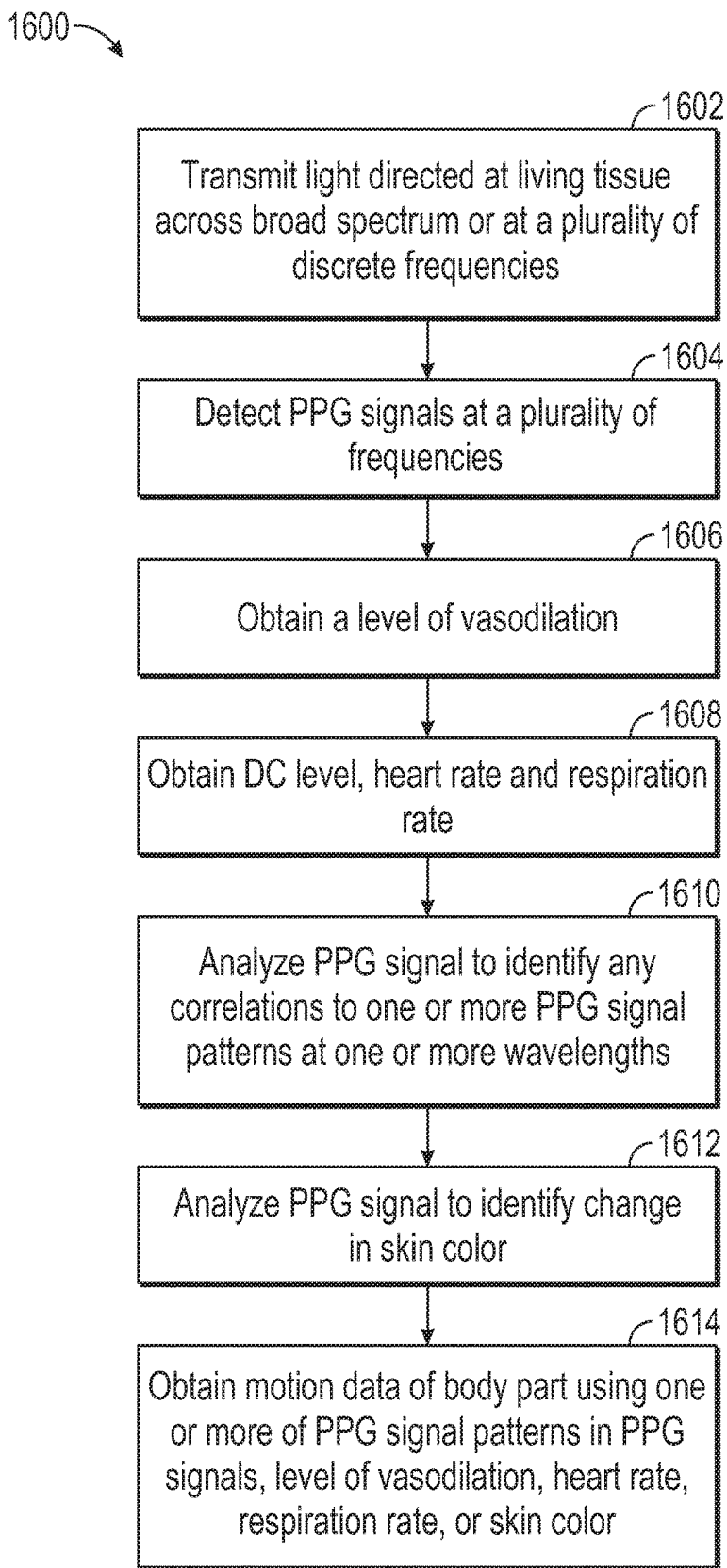

FIG. 16

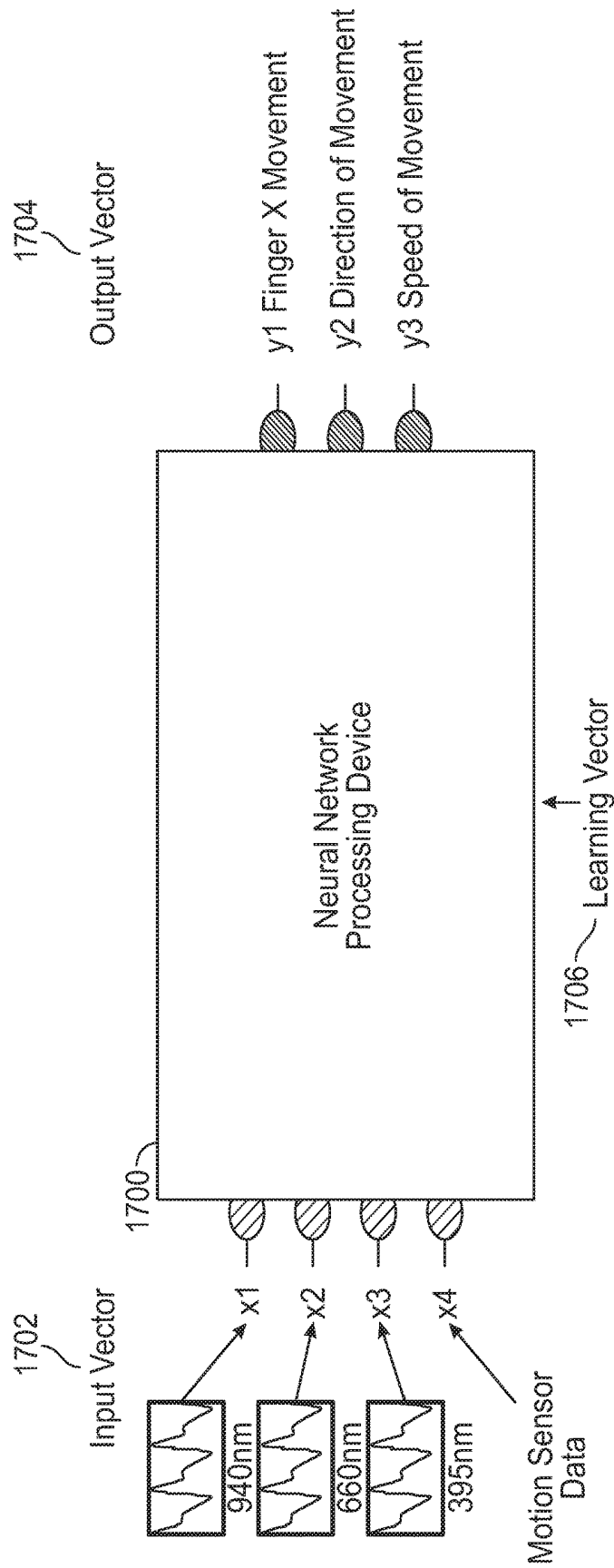

FIG. 17

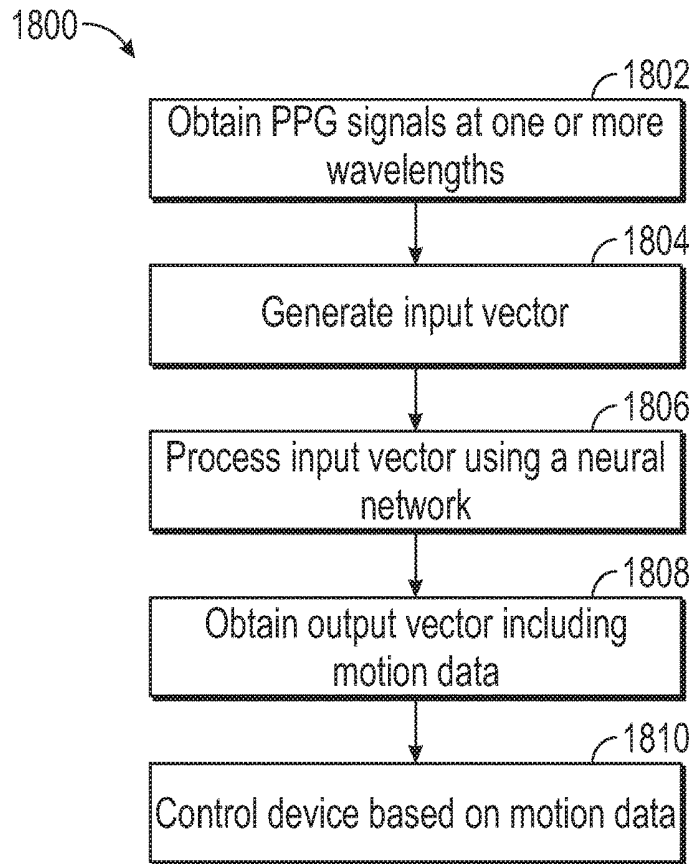

FIG. 18

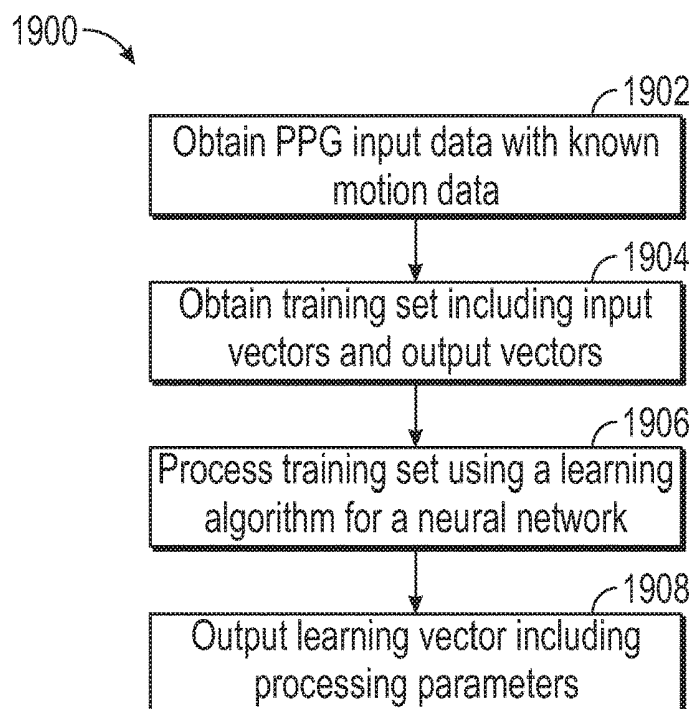

FIG. 19

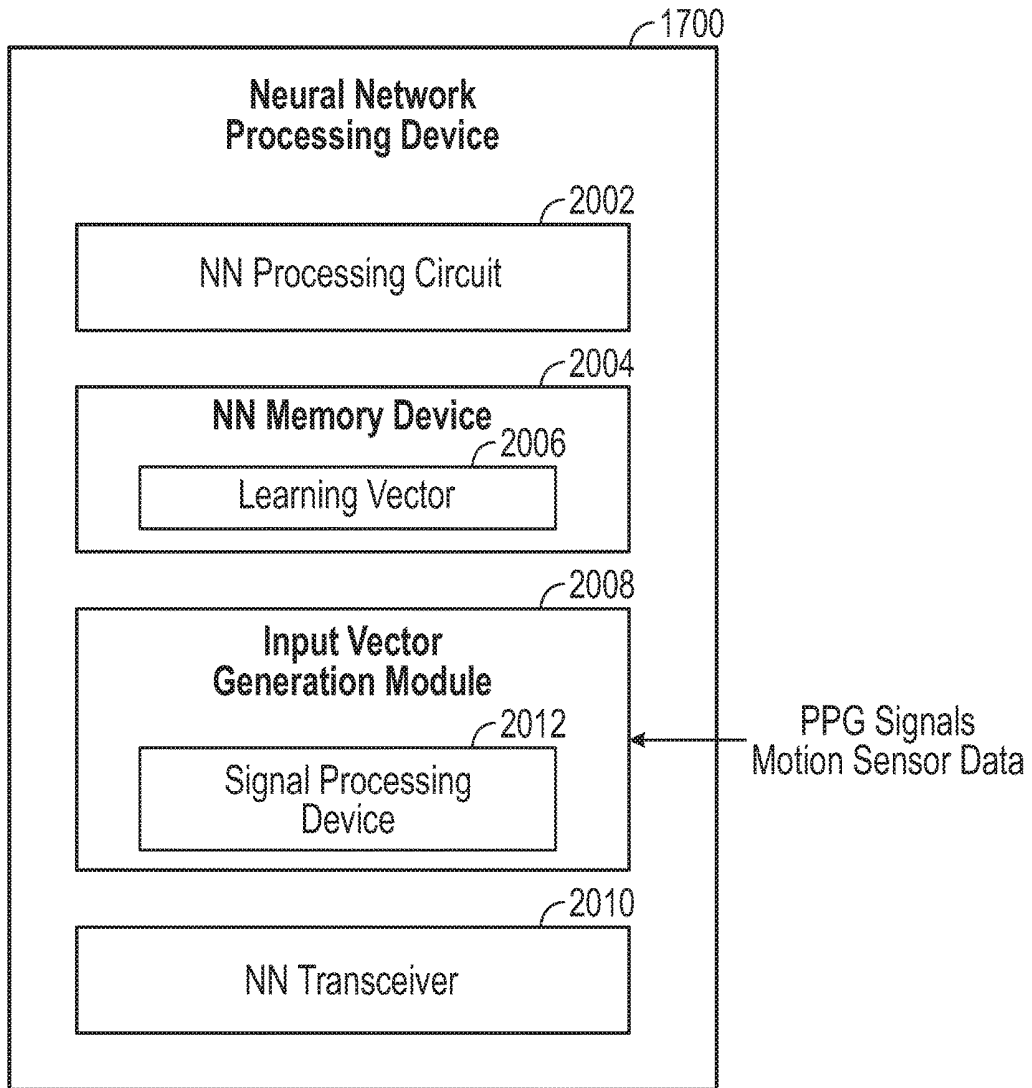

FIG. 20

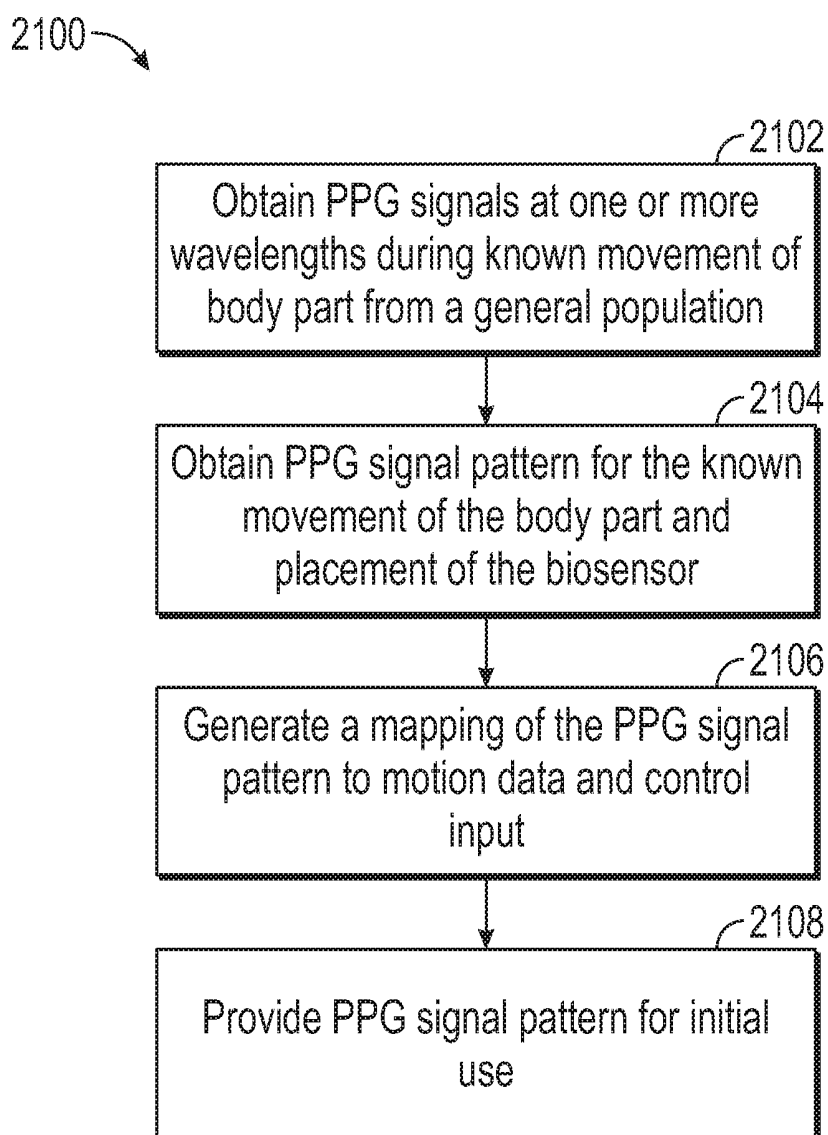

FIG. 21

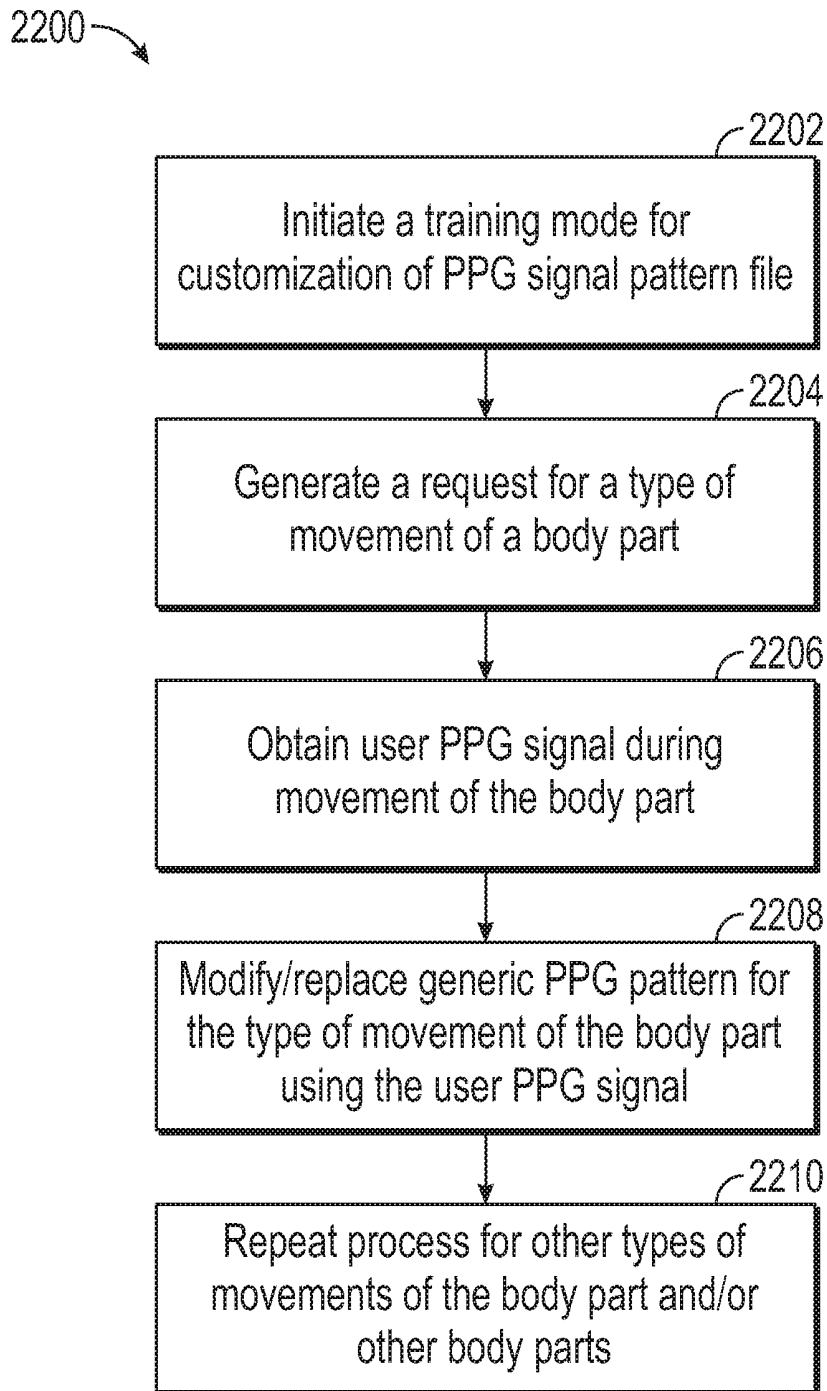

FIG. 22

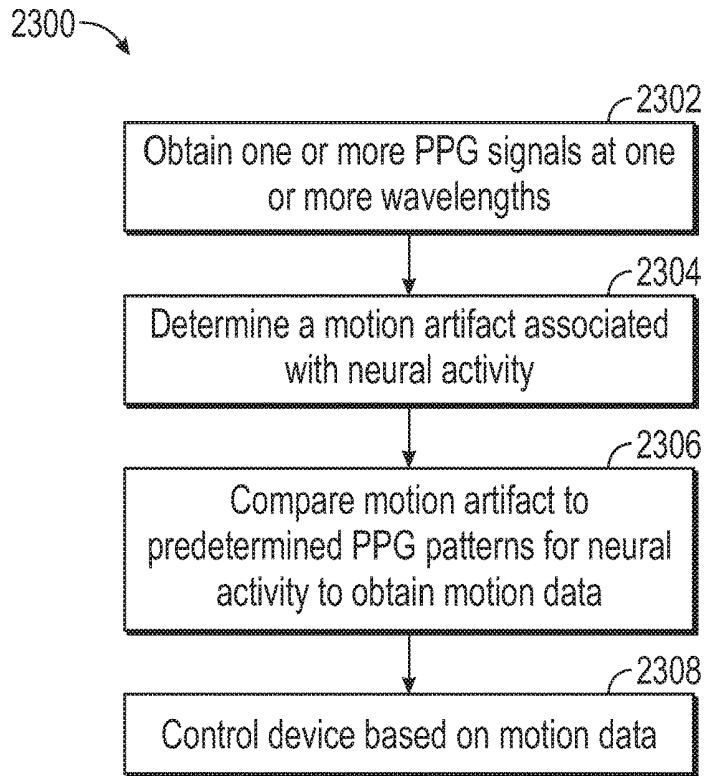

FIG. 23

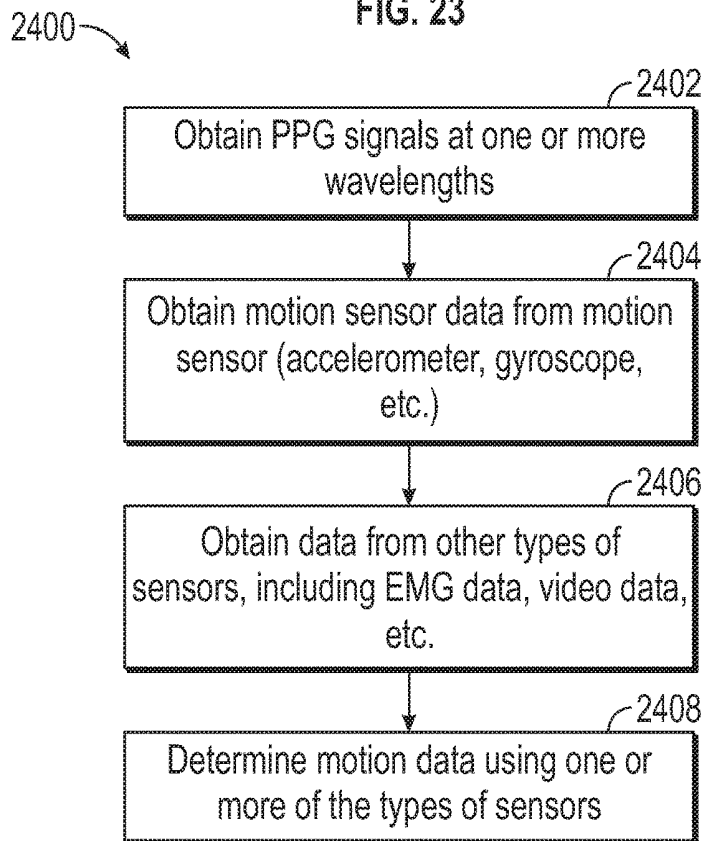

FIG. 24

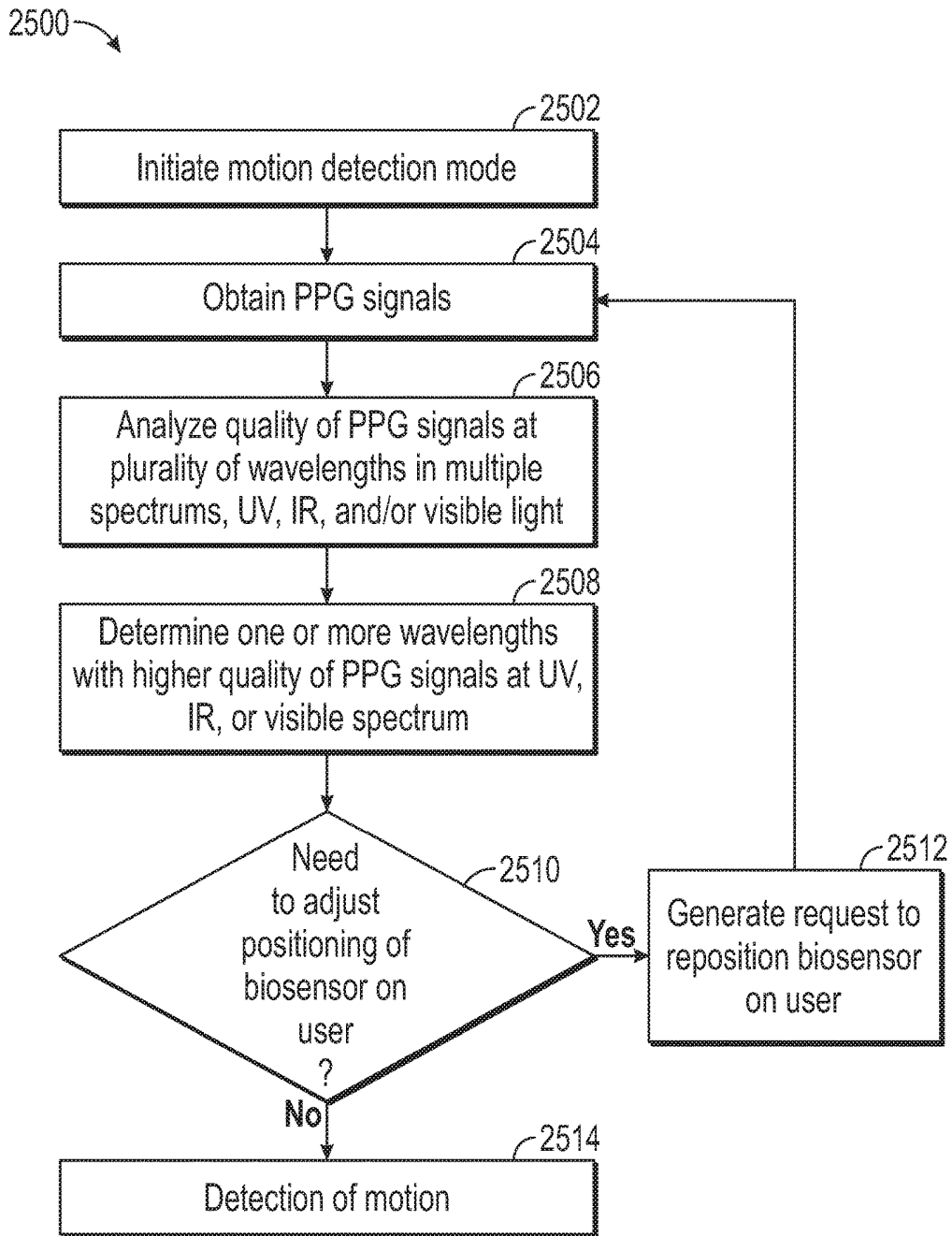

FIG. 25

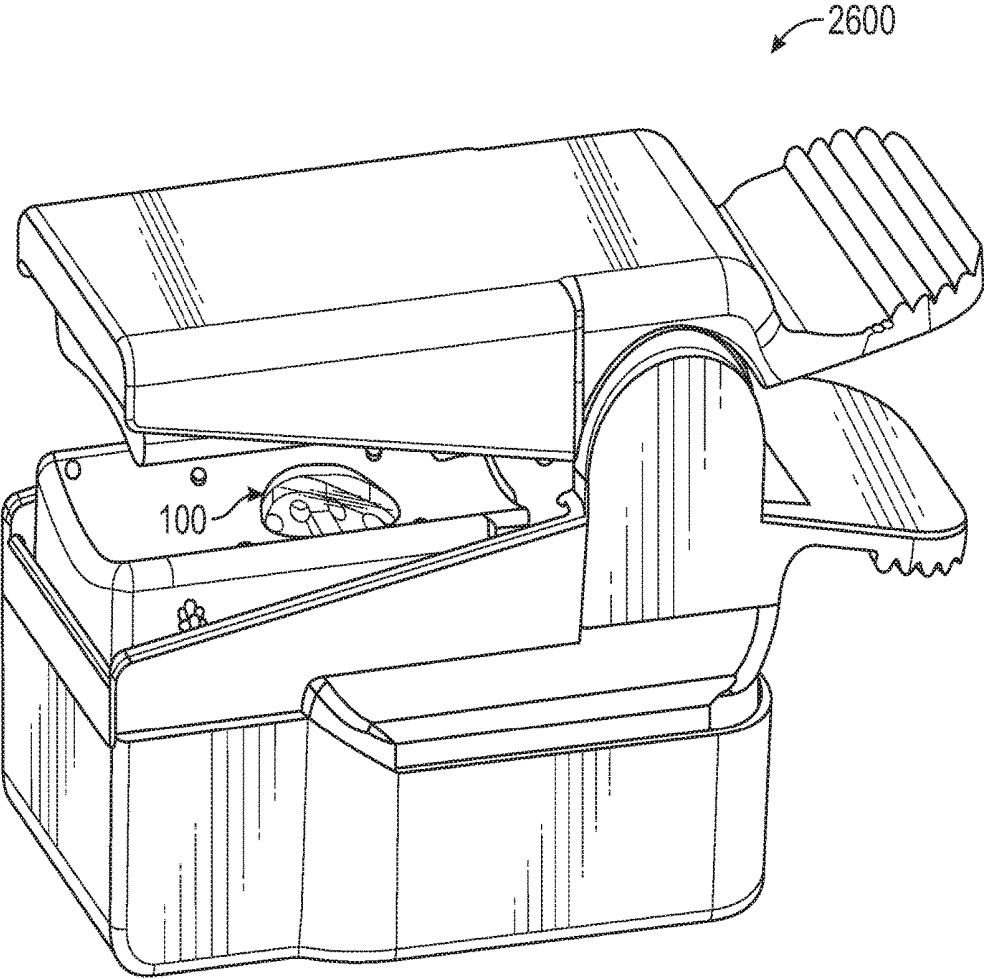

FIG. 26

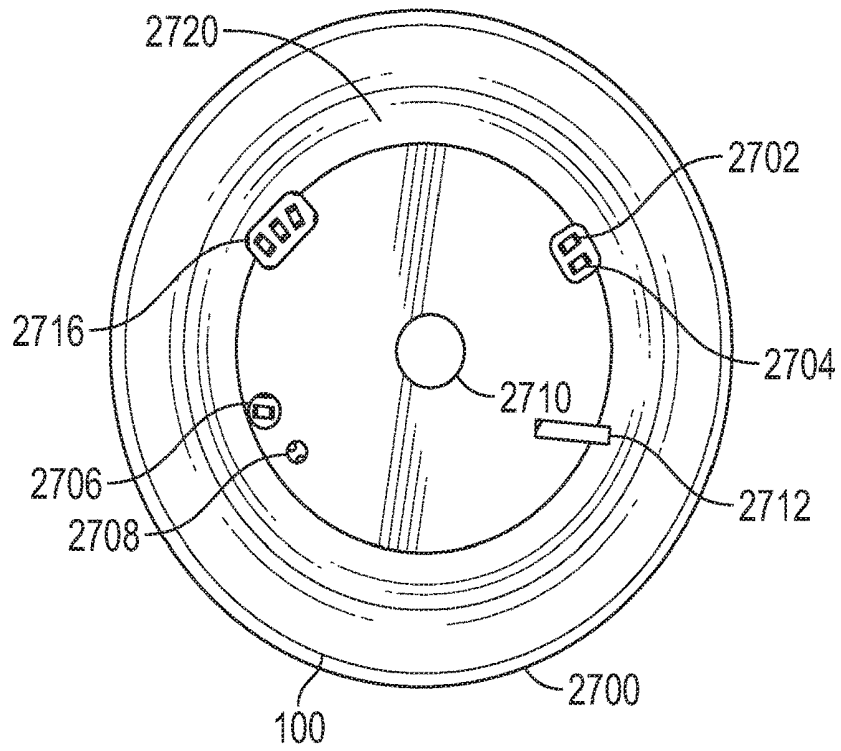

FIG. 27A

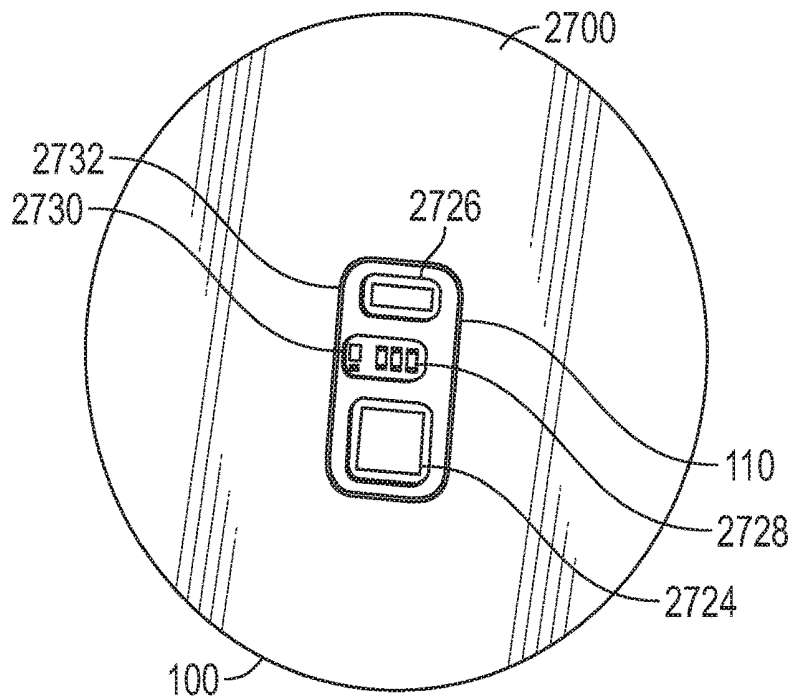

FIG. 27B

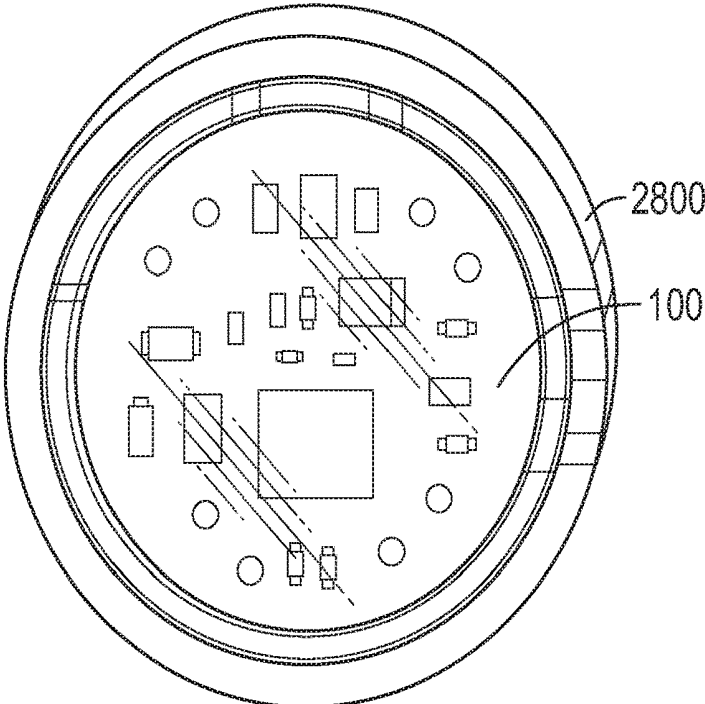

FIG. 28A

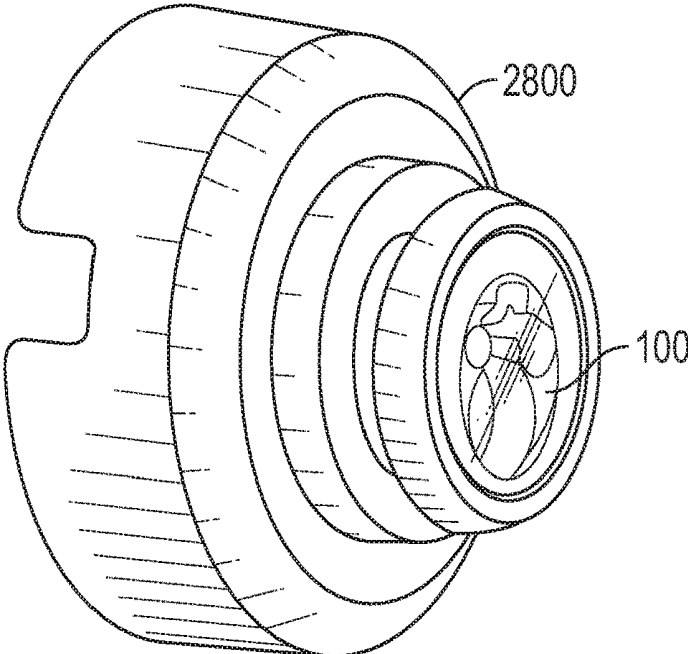

FIG. 28B

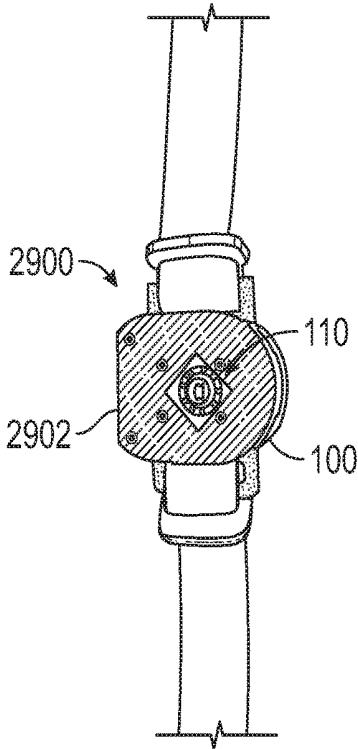

FIG. 29A

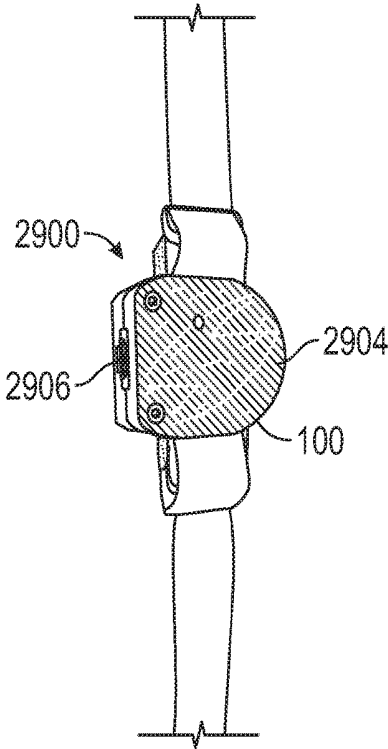

FIG. 29B

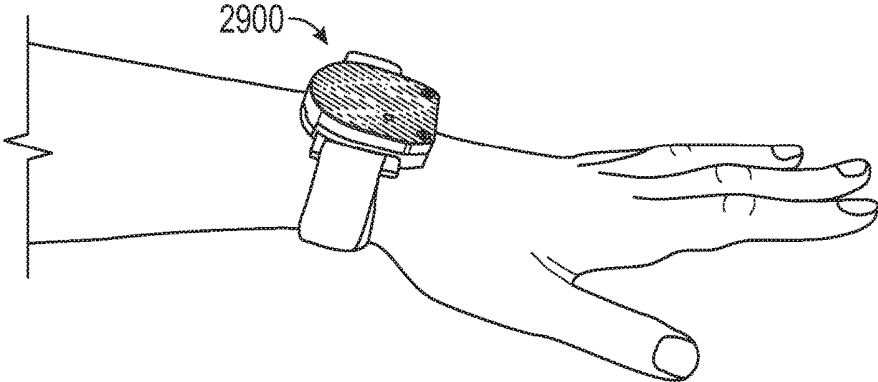

FIG. 29C

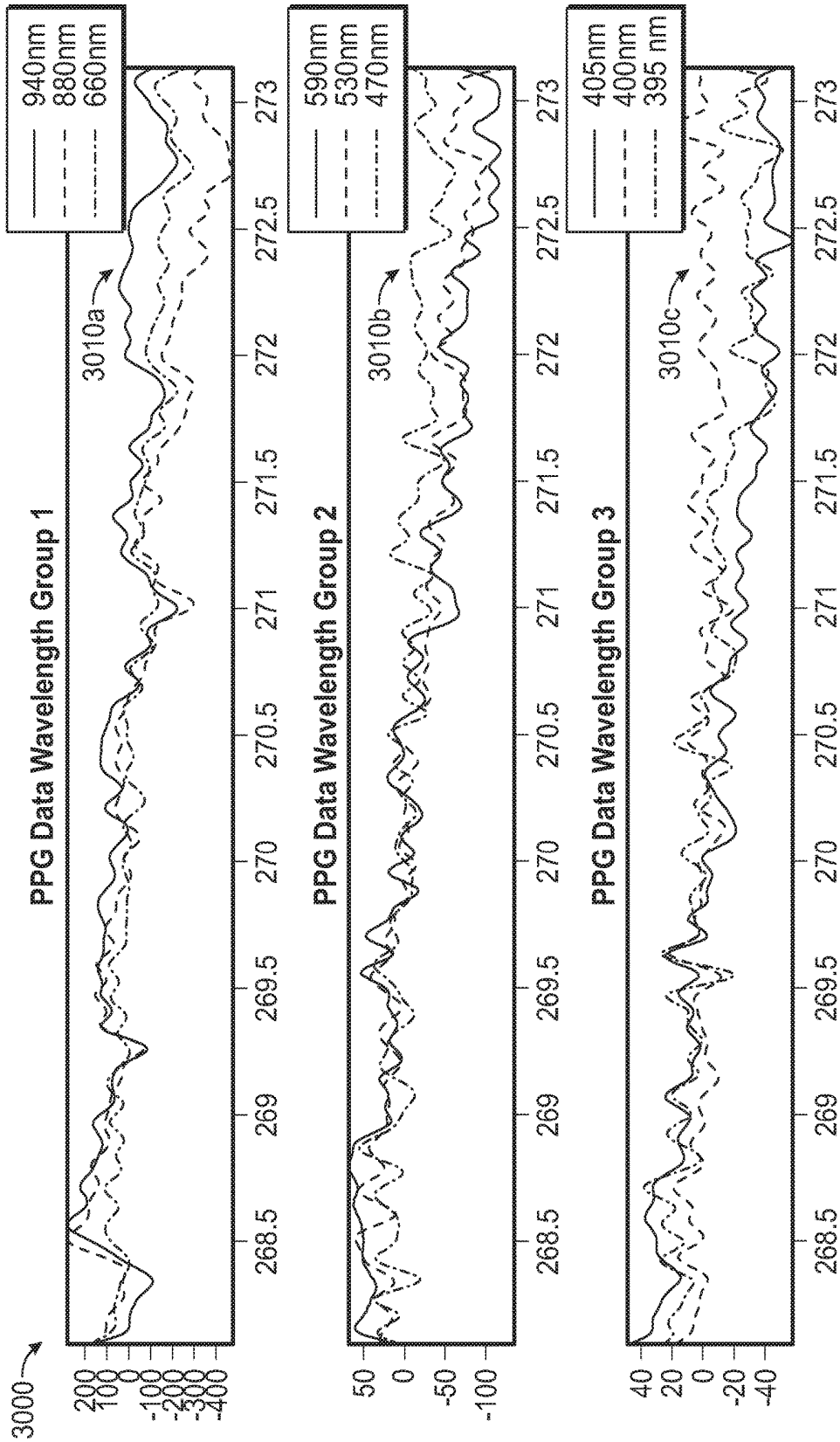
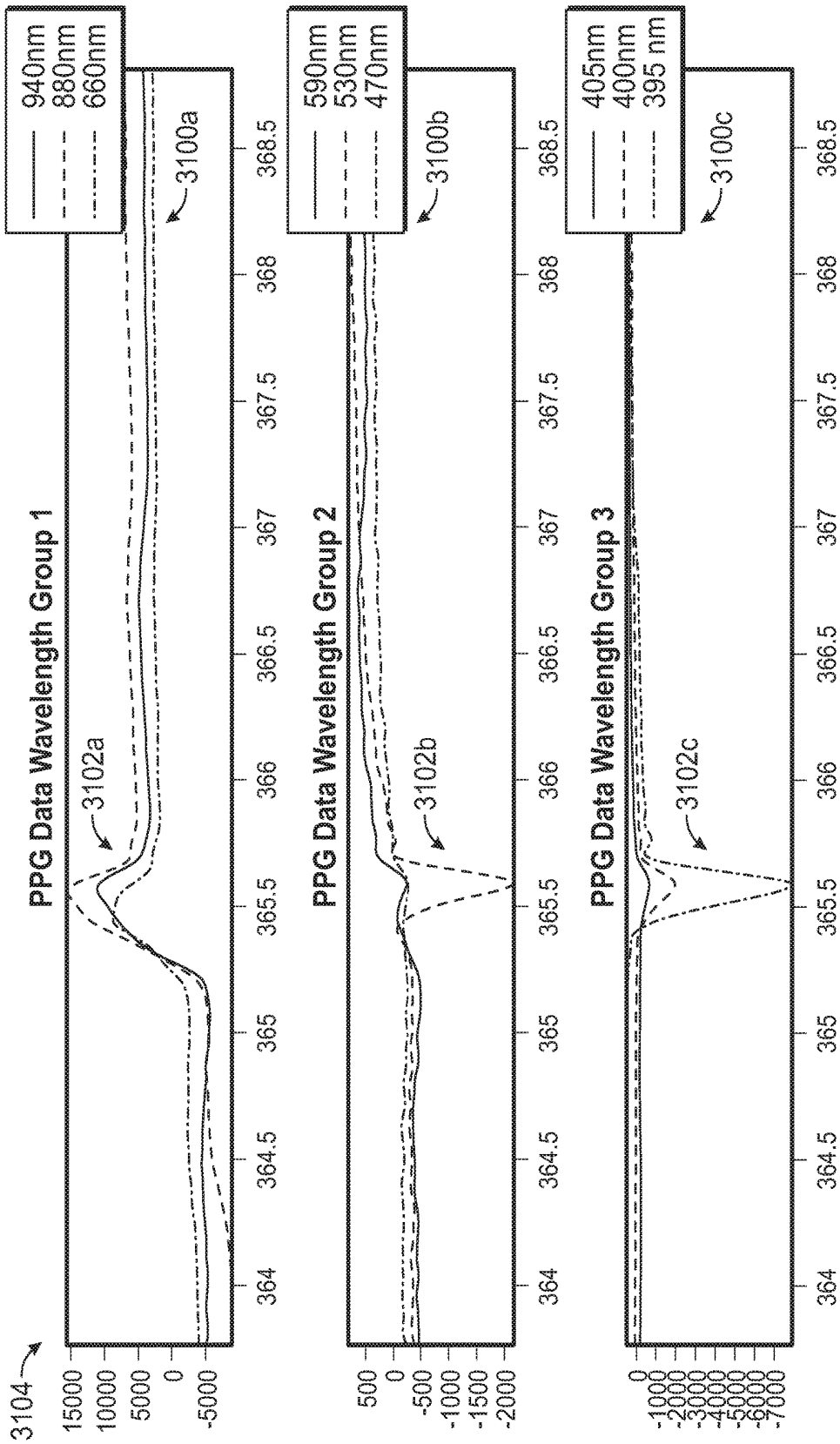
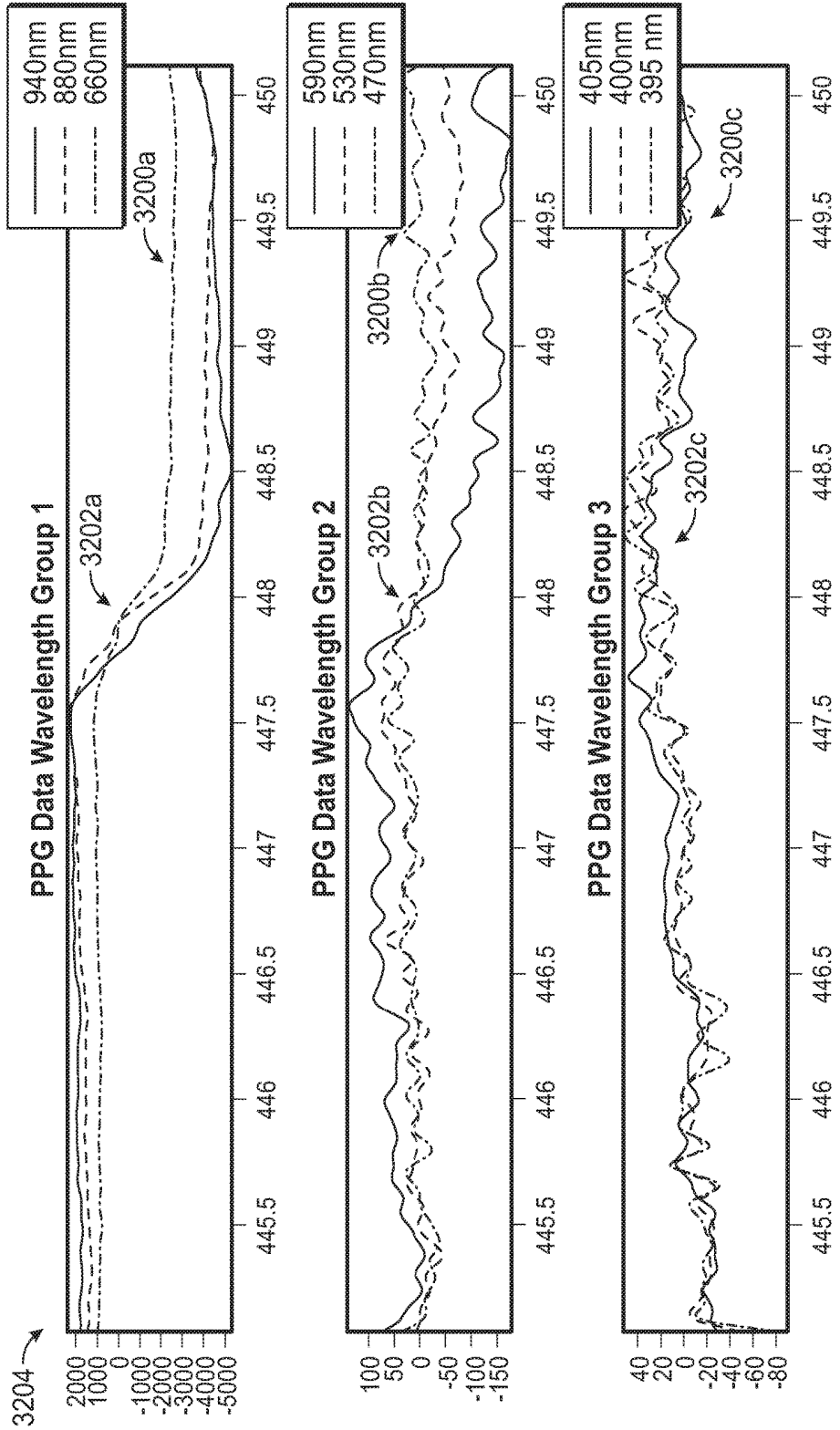

FIG. 30

PPG Signals Recorded During Relaxed Flat Hand





PPG Signals Recorded During Flat Hand with Movement of Thumb Down **FIG. 32**

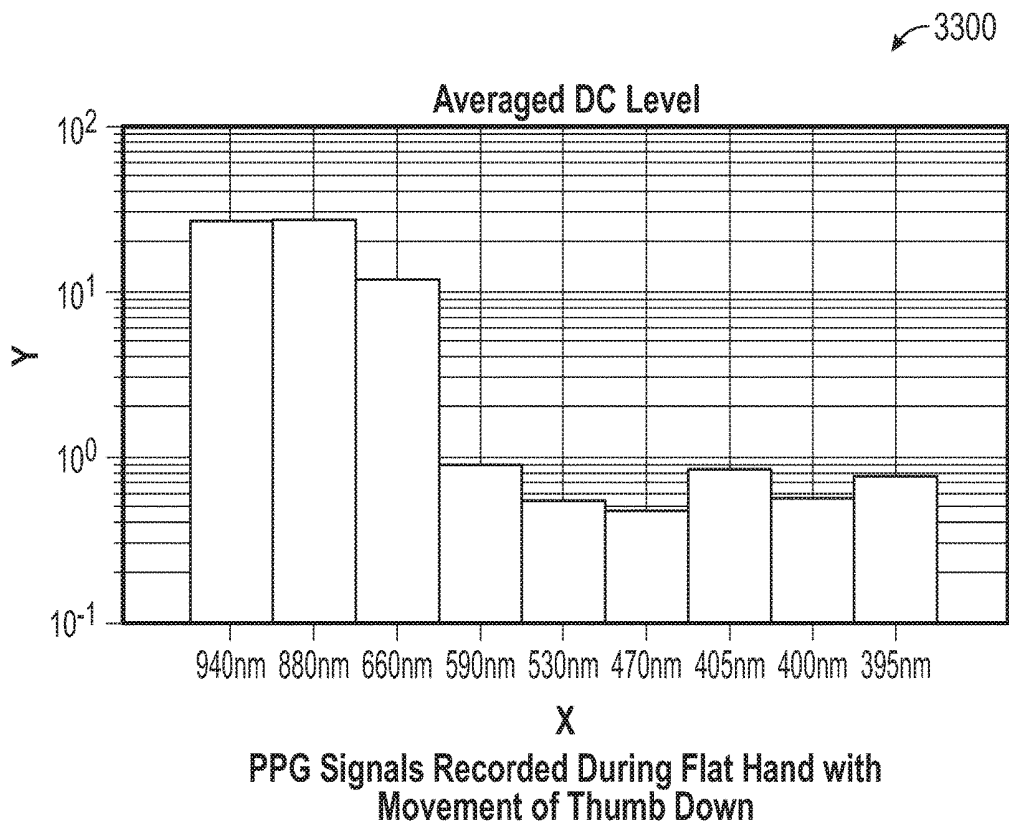

**FIG. 33**

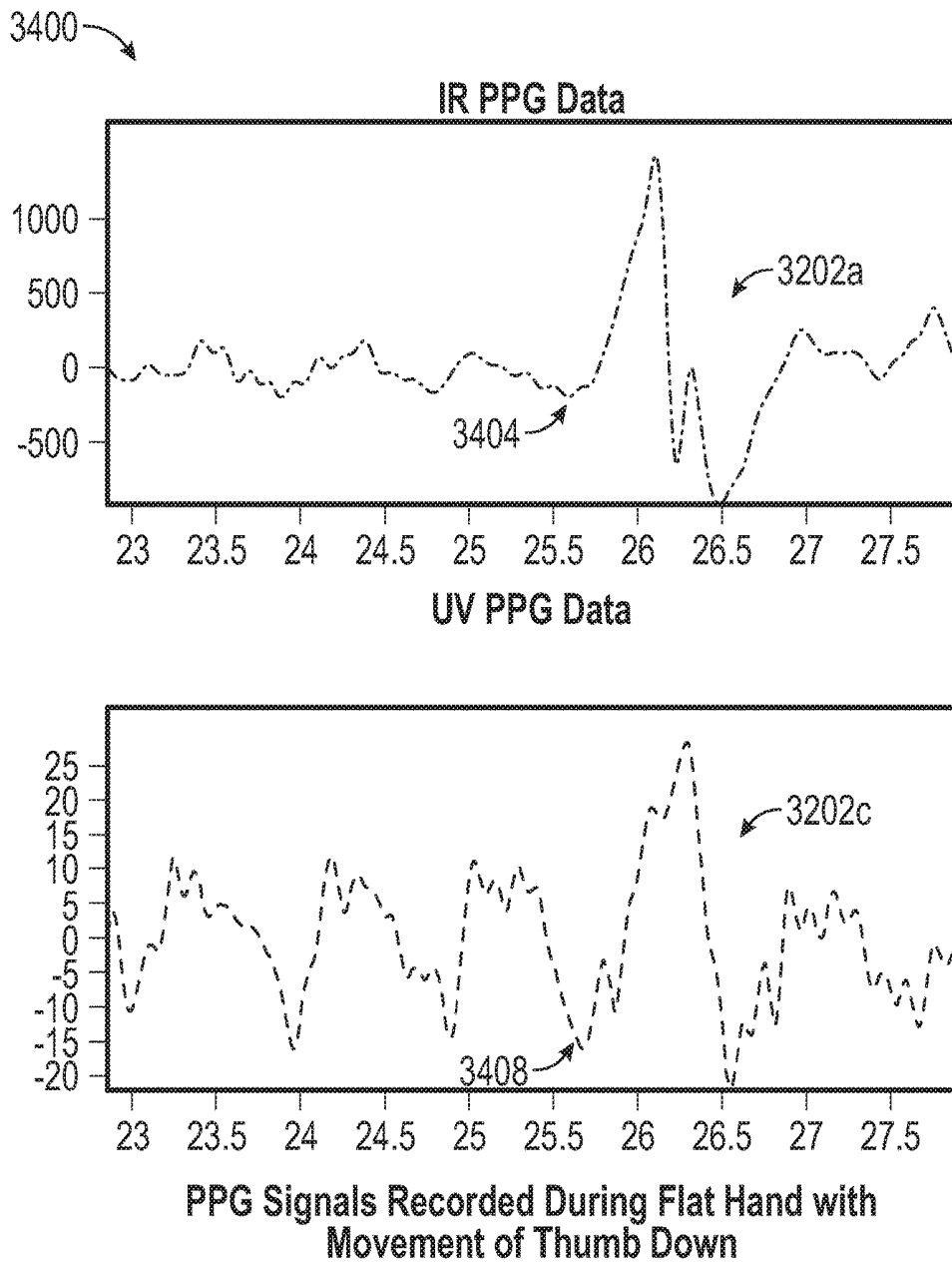
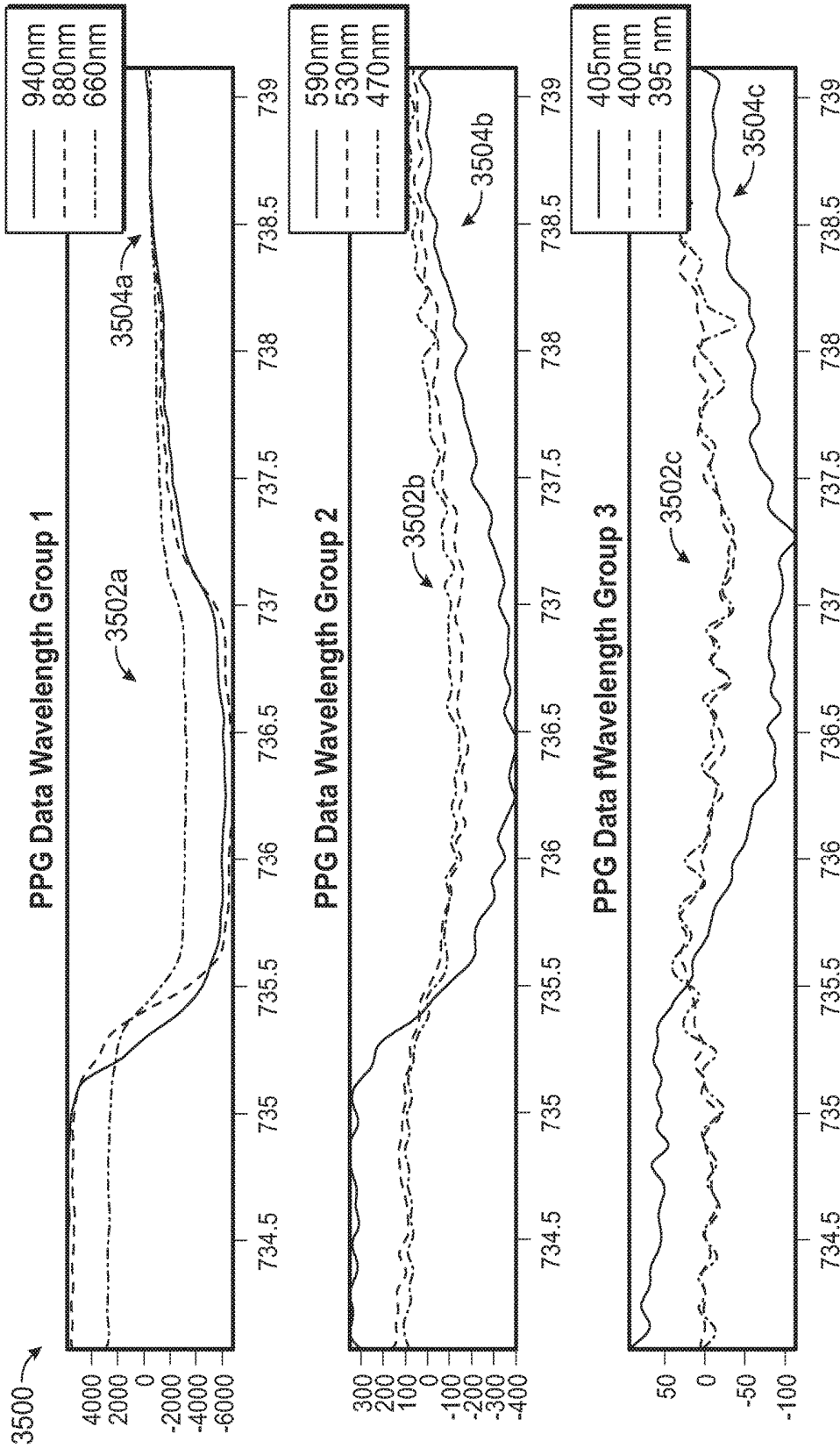

FIG. 34



PPG Signals Recorded During Flat Hand with Upward Movement of Thumb FIG. 35

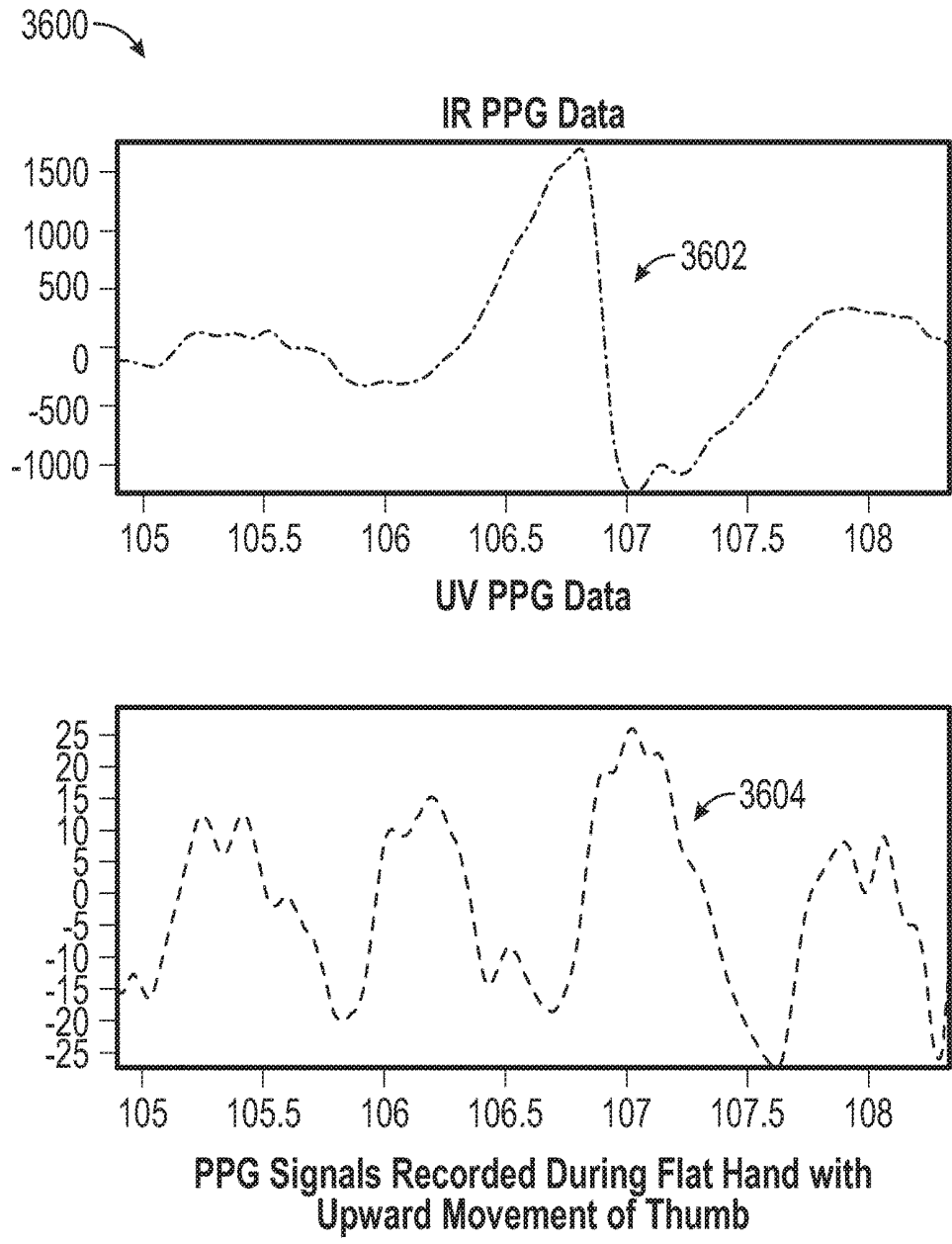

FIG. 36

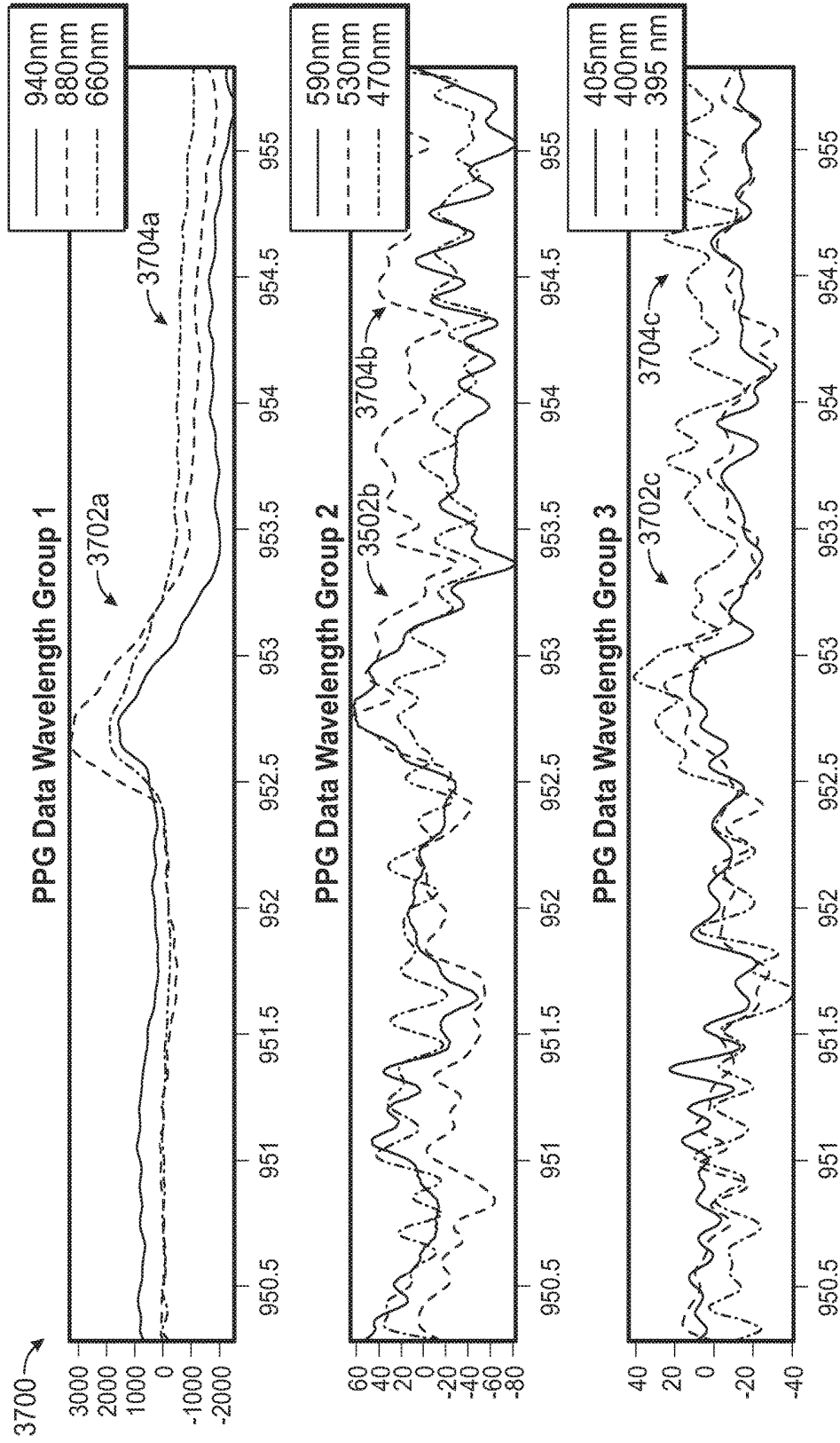

FIG. 37

PPG Signals Recorded with Flat Hand During Upward Movement of Index Finger

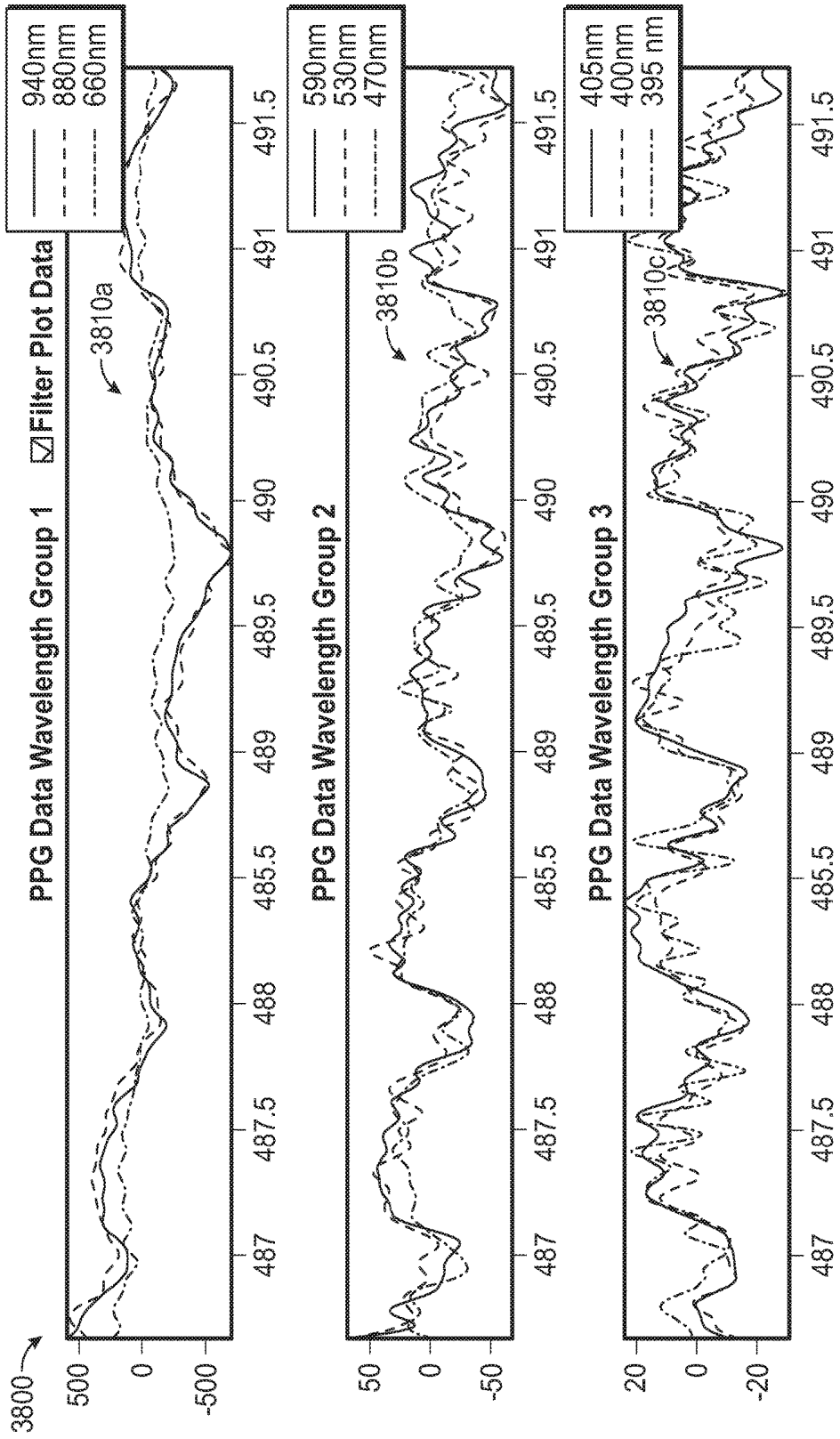
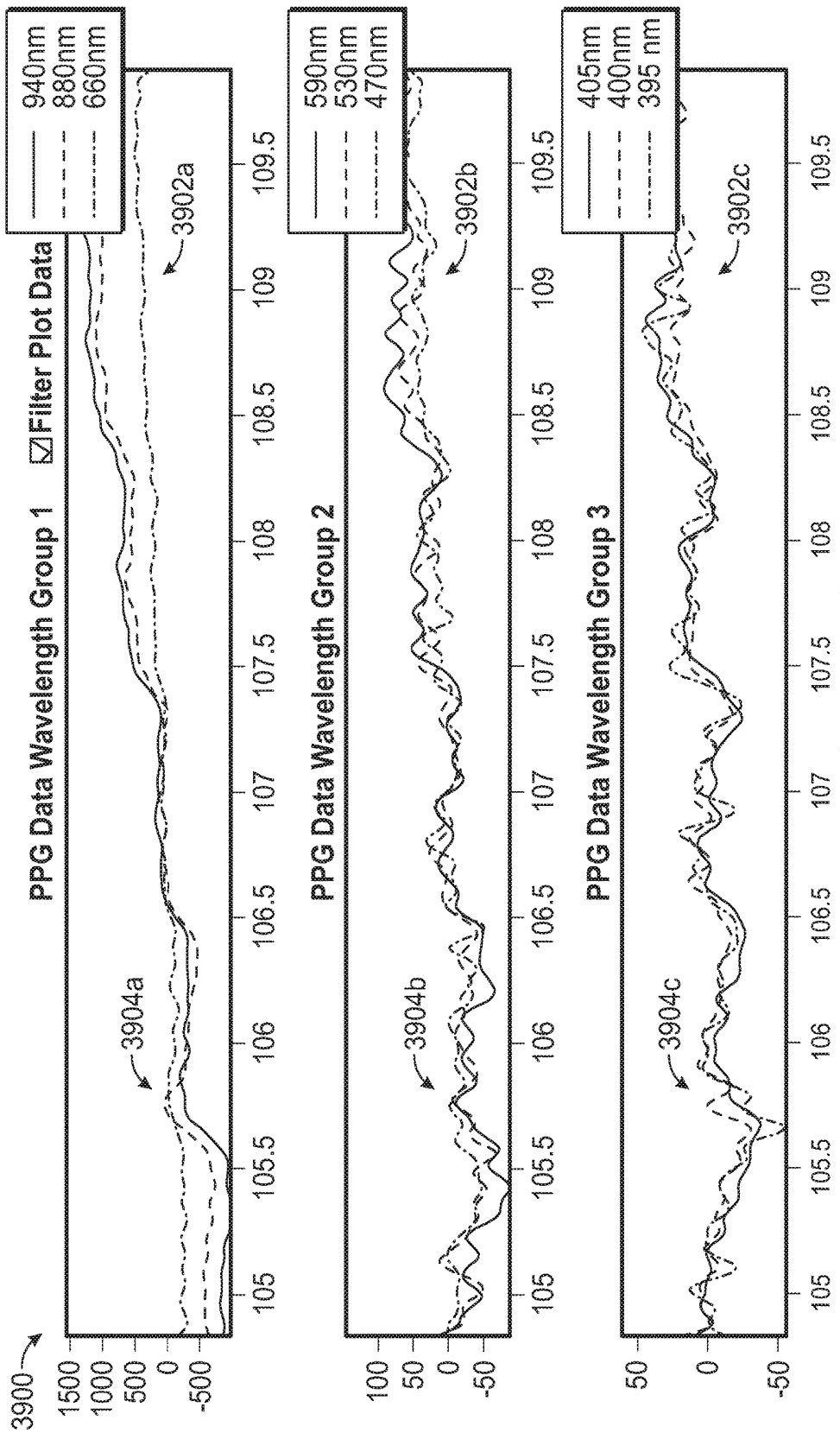
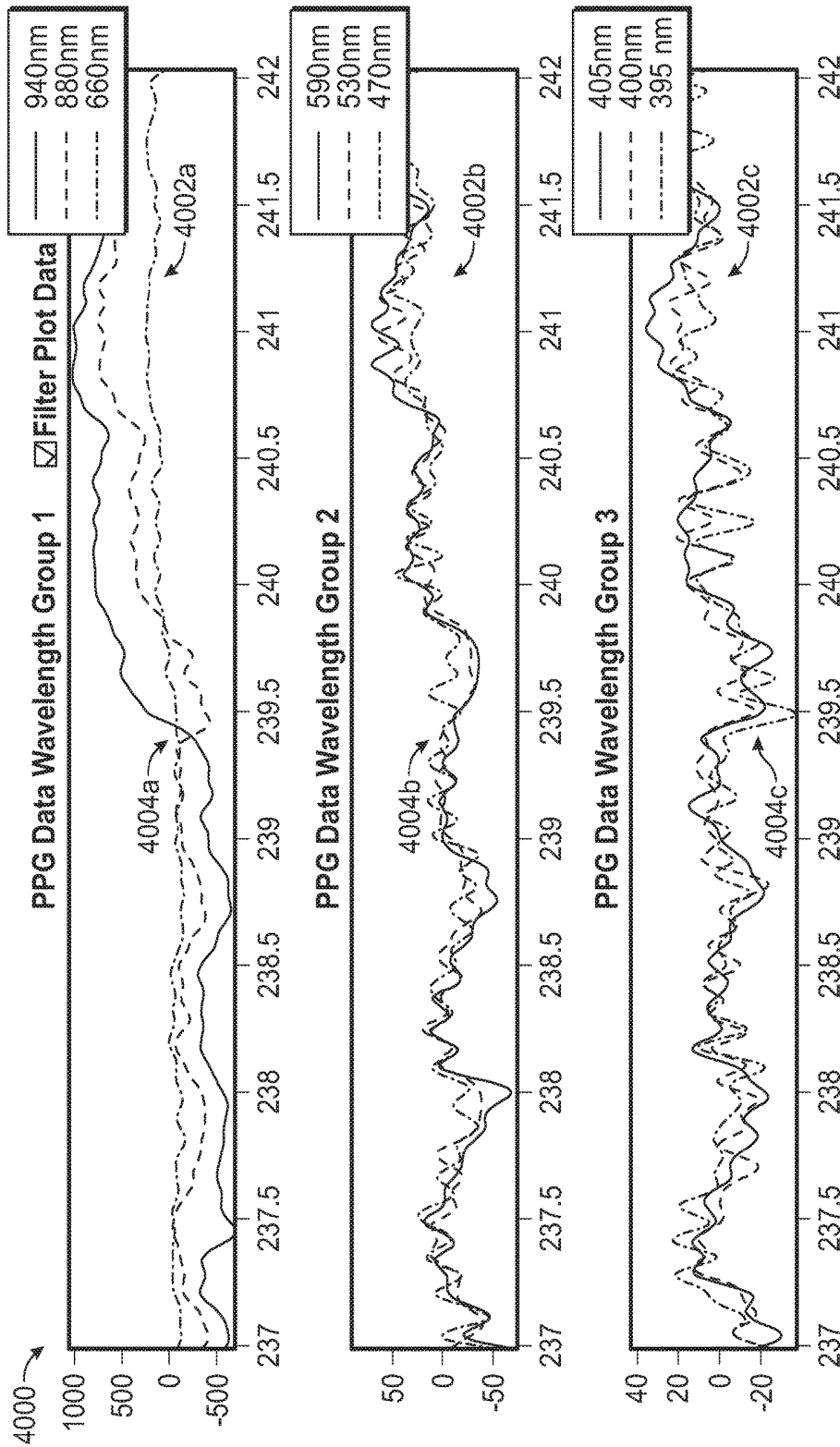

FIG. 38



Hand Relaxed with Mental Intention of Raising Left Index Finger with no Movement **FIG. 39**



Hand Relaxed with Mental Intention of Raising Left Pinky Finger with no Movement FIG. 40

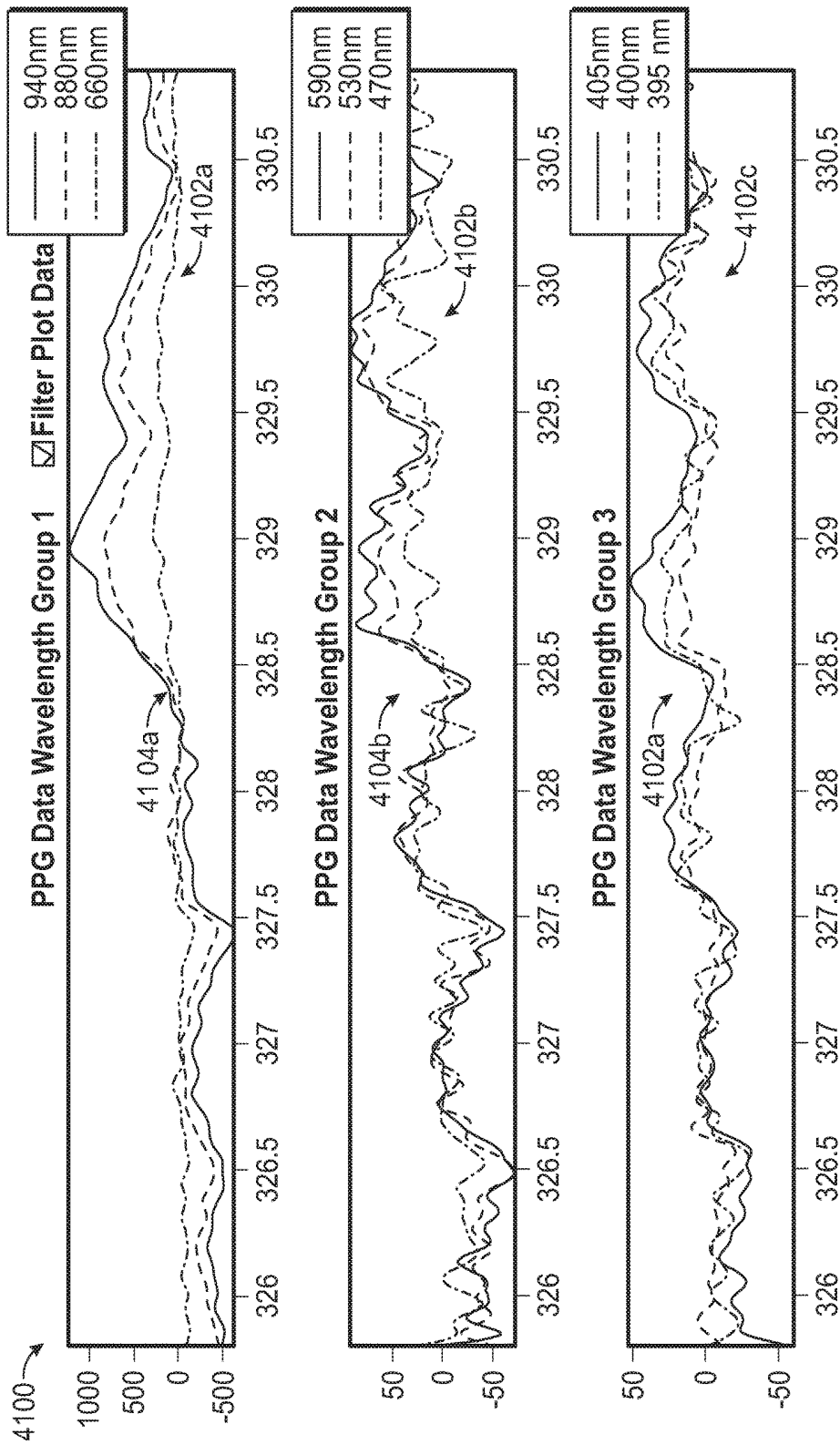

Hand Relaxed with Mental Intention of Raising Left Thumb but with no Movement FIG. 41

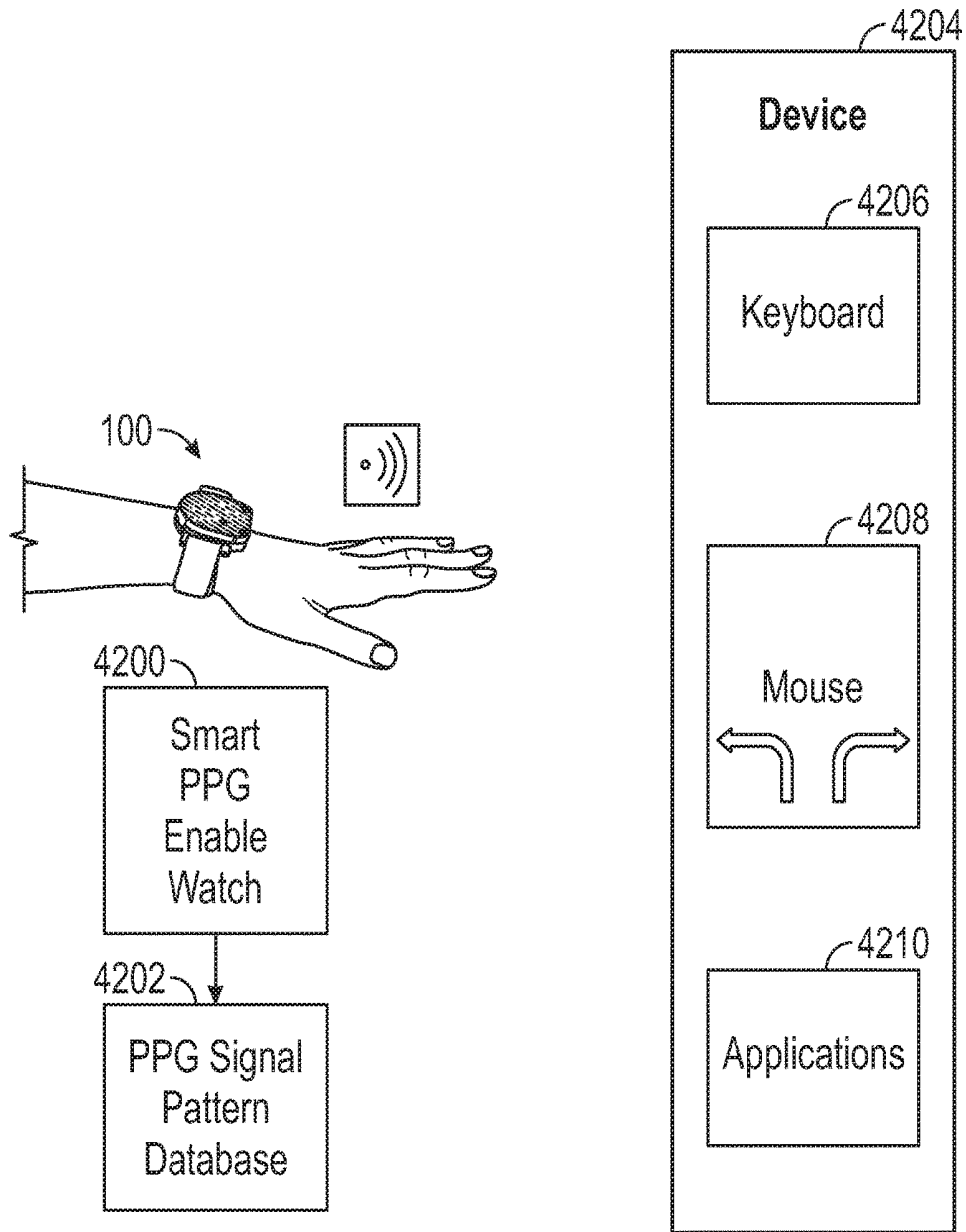
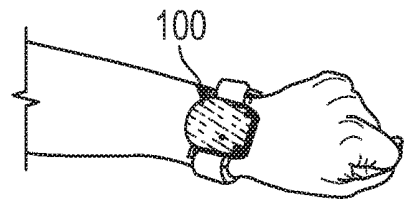
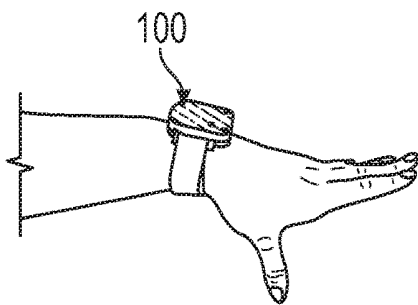
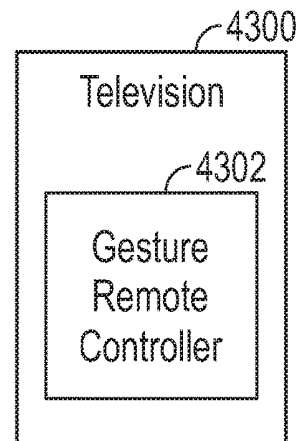
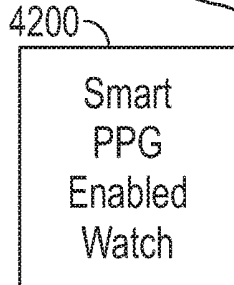
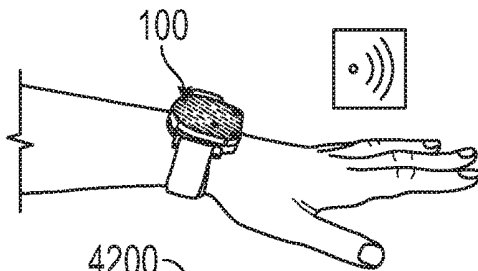

FIG. 42



Examples:  
"Turn off TV"



"Change Channel on TV"

FIG. 43

## SYSTEM AND METHOD FOR MOTION DETECTION USING A PPG SENSOR

### CROSS REFERENCE TO RELATED APPLICATIONS

**[0001]** The present application claims priority under 35 U.S.C. § 119 to U.S. Provisional Application No. 62/675,151 entitled, "SYSTEM AND METHOD OF A BIOSENSOR FOR DETECTION OF VASODILATION," filed May 22, 2018 and is hereby incorporated by reference herein in its entirety.

**[0002]** The present application claims priority under 35 U.S.C. § 119 to U.S. Provisional Application No. 62/643,643 entitled, "SYSTEM AND METHOD FOR MOVEMENT DETECTION USING A PPG SENSOR," filed Mar. 15, 2018 and is hereby incorporated by reference herein in its entirety.

### FIELD

**[0003]** This application relates to a system and method of non-invasive detection of neural stimulation or movement, and in particular to a system and method for monitoring neural stimulation or movement using photoplethysmography (PPG) methods.

### BACKGROUND

**[0004]** Photoplethysmography (PPG) involves obtaining a volumetric measurement of tissue and/or vessels in response to blood flow. One current non-invasive method is known for measuring the oxygen saturation of blood using pulse oximeters. With each cardiac cycle the heart pumps blood through vessels creating a pressure pulse. This pressure pulse distends the arteries and arterioles in the subcutaneous tissue. When the heart pumps blood to the body and the lungs during systole, the amount of blood that reaches the capillaries in the skin surface increases, resulting in more light absorption. The blood then travels back to the heart through the venous network, leading to a decrease of blood volume in the capillaries and less light absorption. The pressure pulse may also be detected in veins, e.g., from the venous plexus. In PPG, a light source is directed at skin tissue and reflected light is detected by a photodetector to generate a PPG signal. The change in blood volume during a pressure pulse affects the amount of light reflected to a photodetector. As such, the pressure pulse appears as a peak in the PPG signal. The measured PPG waveform therefore comprises a pulsatile (often called "AC") physiological waveform that reflects cardiac synchronous changes in the blood volume with each heartbeat, which is superimposed on a much larger slowly varying quasi-static ("DC") baseline.

**[0005]** Heretofore, photoplethysmography was used primarily in pulse oximeters to detect a heart rate and oxygen saturation levels. In pulse oximetry, the subject's skin at a 'measurement location' is illuminated with two distinct wavelengths of light and the relative absorbance at each of the wavelengths is determined. For example, a wavelength in the visible red spectrum (for example, at 660 nm) has an extinction coefficient of hemoglobin that exceeds the extinction coefficient of oxihemoglobin. At a wavelength in the near infrared spectrum (for example, at 940 nm), the extinction coefficient of oxihemoglobin exceeds the extinction coefficient of hemoglobin. The pulse oximeter filters the

absorbance of the pulsatile fraction of the blood, i.e. that due to arterial blood (AC components), from the constant absorbance by nonpulsatile venous or capillary blood and other tissue pigments (DC components), to eliminate the effect of tissue absorbance to measure the oxygen saturation of arterial blood. PPG techniques have also been described for measuring other blood constituents, such as in U.S. Pat. No. 9,642,578, entitled, "System and Method for Health Monitoring using a Non-Invasive, Multiband Biosensor," issued on May 9, 2017, and incorporated by reference herein in its entirety. In general, when detecting such blood constituents, motion artifacts in the PPG signals are ignored or filtered from the signals.

**[0006]** In one or more embodiments described herein, the PPG signal is used to non-invasively detect movement and/or neural stimulation of a body part of a user.

### SUMMARY

**[0007]** According to a first aspect, a biosensor includes a sensor configured to obtain a photoplethysmography (PPG) signal, wherein the PPG signal includes a spectral response around a first wavelength of light detected from skin tissue of a user. The biosensor further includes a processing device configured to process the PPG signal at the first wavelength to identify a motion artifact and correlate the motion artifact in the PPG signal to a predetermined PPG signal pattern. The processing device configured to obtain first motion data for a body part using the predetermined PPG signal pattern and control operation of a device in response to the movement.

**[0008]** According to second aspect, a wearable device is configured for detecting movement of a body part and includes a PPG sensor configured to obtain a PPG waveform from light detected from skin of a user. The wearable device further includes a processing circuit in communication with the PPG sensor and configured to identify a motion artifact in the PPG waveform and compare the motion artifact to a plurality of predetermined PPG patterns in a database, wherein each of the predetermined PPG patterns is associated with a movement of a body part. The processing circuit is further configured to correlate the motion artifact in the PPG waveform to a first predetermined PPG pattern in the database and determine the movement of the body part for the user based on the first predetermined PPG pattern and the associated movement of the body part in the database.

**[0009]** According to a third aspect, a biosensor includes a sensor configured to obtain a PPG signal, wherein the PPG signal includes a spectral response around a first wavelength of light detected from skin tissue of a user. The biosensor further includes a processing device that identifies a motion artifact in the PPG signal and correlates the motion artifact in the PPG signal to a predetermined PPG signal pattern for intended movement. The processing device may further obtain first motion data for a body part using the predetermined PPG signal pattern, wherein the motion data identifies an intended movement of a body part and control operation of a device in response to the motion data.

**[0010]** In one or more of the above aspects, the predetermined PPG signal pattern is associated with motion data, wherein the motion data includes one or more of: an identification of a moving body part or a motion vector for the moving body part. The motion vector indicates one or more of: a direction of the movement, a speed of the movement or a force of the movement.

[0011] In one or more of the above aspects, the processing device processes a second PPG signal at a second wavelength to identify a second motion artifact in the second PPG signal, correlates the second motion artifact in the second PPG signal to a second predetermined PPG signal pattern, and obtains second motion data using the second predetermined PPG signal pattern. The processing device may further compare the first motion data and the second motion data for verification.

[0012] In one or more of the above aspects, the biosensor may obtain a direct current (DC) level or maximum amplitude of the motion artifact and determine a force of movement of the body part using the DC level or the maximum amplitude level.

[0013] In one or more of the above aspects, the biosensor may process the PPG signal at the first wavelength to identify a level of vasodilation and determine the movement of the body part using the level of vasodilation.

[0014] In one or more of the above aspects, the processing device is a neural network processing device and an input vector is generated using the PPG signal. The neural network processing device generates an output vector including one or more of: identification of the movement of the body part, direction of the movement, speed of the movement or force of the movement.

#### BRIEF DESCRIPTION OF THE DRAWINGS

[0015] FIG. 1 illustrates a schematic block diagram of exemplary components in an embodiment of the biosensor.

[0016] FIG. 2 illustrates a schematic block diagram of an embodiment of the PPG circuit in more detail.

[0017] FIG. 3 illustrates a schematic block diagram of another embodiment of a PPG circuit implemented within a camera.

[0018] FIG. 4 illustrates a logical flow diagram of an embodiment of a method for motion detection using a PPG signal.

[0019] FIG. 5 illustrates a schematic diagram of a graph of spectral responses obtained using an embodiment of the biosensor during a period of little to no motion.

[0020] FIG. 6 illustrates a schematic diagram of a graph of spectral responses obtained using an embodiment of the biosensor during movement of a thumb on a right hand of the user.

[0021] FIG. 7 illustrates a schematic diagram of a graph of spectral responses obtained using an embodiment of the biosensor during movement of an index finger on a right hand of the user.

[0022] FIG. 8 illustrates a schematic diagram of a graph of spectral responses obtained using an embodiment of the biosensor during movement of a middle finger on a right hand of the user.

[0023] FIG. 9 illustrates a schematic diagram of a graph of spectral responses obtained using an embodiment of the biosensor during movement of a fourth finger on a right hand of the user.

[0024] FIG. 10 illustrates a schematic diagram of a graph of spectral responses obtained using an embodiment of the biosensor during movement of a fifth finger on a right hand of the user.

[0025] FIG. 11 illustrates a schematic diagram of a comparison of PPG signals obtained during movement of the fingers on the right hand.

[0026] FIG. 12 illustrates a logical flow diagram of an embodiment of a method for obtaining motion data by the biosensor.

[0027] FIG. 13 illustrates a schematic diagram of a graph of PPG signals during a period of vasodilation in vessels.

[0028] FIG. 14 illustrates a schematic diagram of heart rate and lower frequency components of PPG signals during a period of vasodilation.

[0029] FIG. 15A illustrates a schematic diagram of graphs of the phase difference of the PPG signals at different wavelengths during a period of vasodilation.

[0030] FIG. 15B illustrates a schematic diagram of graphs of the average phase difference between waveforms in PPG signals of various wavelengths after the period of vasodilation.

[0031] FIG. 16 illustrates a logical flow diagram of an embodiment of another method for obtaining motion data by the biosensor.

[0032] FIG. 17 illustrates a schematic block diagram of an embodiment of a neural network processing device.

[0033] FIG. 18 illustrates a logical flow diagram of an embodiment of a method for using machine learning techniques for motion detection using PPG signals at one or more wavelengths.

[0034] FIG. 19 illustrates a logical flow diagram of an embodiment of a method of generating a learning vector from a training set.

[0035] FIG. 20 illustrates a schematic block diagram of an embodiment of a neural network processing device in more detail.

[0036] FIG. 21 illustrates a logical flow diagram of an embodiment of a method for generating PPG signal patterns.

[0037] FIG. 22 illustrates a logical flow diagram of an embodiment of a method for a training mode to determine customized PPG signal patterns.

[0038] FIG. 23 illustrates a logical flow diagram of an embodiment of a method for detecting neural activity using PPG signals.

[0039] FIG. 24 illustrates a logical flow diagram of an embodiment of a method for detecting neural activity or movement of a body part using one or more types of sensors.

[0040] FIG. 25 illustrates a logical flow diagram of an embodiment of a method for positioning of a biosensor.

[0041] FIG. 26 illustrates a schematic block diagram of an embodiment of the biosensor integrated in a finger attachment.

[0042] FIG. 27A illustrates a perspective view of a first side of another embodiment of the biosensor integrated in a patch.

[0043] FIG. 27B illustrates a perspective view of a second side of an embodiment of the biosensor integrated in the patch.

[0044] FIG. 28A illustrates a perspective view of an embodiment of the biosensor configured in an earpiece.

[0045] FIG. 28B illustrates another perspective view of the biosensor integrated in the earpiece.

[0046] FIG. 29A illustrates a perspective view of an embodiment of a bottom portion of a wristband including an integrated biosensor.

[0047] FIG. 29B illustrates a perspective view of an embodiment of a top portion of the wristband including the biosensor.

[0048] FIG. 30 illustrates a schematic diagram of a graph of spectral responses obtained using an embodiment of the biosensor while the hand is relaxed.

[0049] FIG. 31 illustrates a schematic diagram of a graph of spectral responses obtained using an embodiment of the biosensor during movement of the hand into a fist.

[0050] FIG. 32 illustrates a schematic diagram of a graph of spectral responses obtained using an embodiment of the biosensor during a downward thumb movement.

[0051] FIG. 33 illustrates a schematic diagram of a graph of data generated from the spectral responses obtained using an embodiment of the biosensor during the downward thumb movement.

[0052] FIG. 34 illustrates a schematic diagram of a graph of additional data generated from the spectral responses obtained using an embodiment of the biosensor during the downward thumb movement.

[0053] FIG. 35 illustrates a schematic diagram of a graph of spectral responses obtained using an embodiment of the biosensor during an upward thumb movement.

[0054] FIG. 36 illustrates a schematic diagram of a graph of additional data generated from the spectral responses obtained using an embodiment of the biosensor during the upward thumb movement.

[0055] FIG. 37 illustrates a schematic diagram of a graph of spectral responses obtained using an embodiment of the biosensor during an upward movement of the index finger.

[0056] FIG. 38 illustrates a schematic diagram of a graph of spectral responses obtained using an embodiment of the biosensor while the left hand is relaxed.

[0057] FIG. 39 illustrates a schematic diagram of a graph of spectral responses obtained using an embodiment of the biosensor during a mental intention to move a left index finger but with little to no actual movement.

[0058] FIG. 40 illustrates a schematic diagram of a graph of spectral responses obtained using an embodiment of the biosensor during a mental intention to move a pinky finger upward but with little to no actual movement.

[0059] FIG. 41 illustrates a schematic diagram of a graph of spectral responses obtained using an embodiment of the biosensor during a mental intention to move a left thumb upward but with little to no actual movement.

[0060] FIG. 42 illustrates a schematic block diagram of an embodiment of the biosensor configured to control a device using PPG signals.

[0061] FIG. 43 illustrates a schematic block diagram of another embodiment of the biosensor configured to control a device using PPG signals.

#### DETAILED DESCRIPTION

[0062] The word “exemplary” or “embodiment” is used herein to mean “serving as an example, instance, or illustration.” Any implementation or aspect described herein as “exemplary” or as an “embodiment” is not necessarily to be construed as preferred or advantageous over other aspects of the disclosure. Likewise, the term “aspects” does not require that all aspects of the disclosure include the discussed feature, advantage, or mode of operation.

[0063] Embodiments will now be described in detail with reference to the accompanying drawings. In the following description, numerous specific details are set forth in order to provide a thorough understanding of the aspects described herein. It will be apparent, however, to one skilled in the art, that these and other aspects may be practiced without some

or all of these specific details. In addition, well known steps in a method of a process may be omitted from flow diagrams presented herein in order not to obscure the aspects of the disclosure. Similarly, well known components in a device may be omitted from figures and descriptions thereof presented herein in order not to obscure the aspects of the disclosure.

#### Overview

[0064] In an embodiment, a bio sensor includes an optical or photoplethysmography (PPG) circuit configured to transmit light at one or more wavelengths directed at skin tissue of a user or patient. The user/patient may include any living organism, human or non-human. The PPG circuit detects light reflected from the skin tissue of the user or transmitted through the skin tissue and generates one or more spectral responses at one or more wavelengths. A processing circuit integrated in the biosensor or in communication with the biosensor processes the spectral data to obtain a user’s vitals, concentrations of substances in blood flow and/or other health information. Alternatively, or in addition thereto, the spectral responses at one or more wavelengths are analyzed to detect motion data. For example, the PPG waveforms may be analyzed to detect a movement of a user, such as a user’s hand or a finger, as described in more detail herein. The movement recognition may then be used for providing instructions and control of an input device (such as a keyboard, touchpad or mouse) or can be used for any electronic system needing man-machine interaction.

#### Embodiment—Biosensor

[0065] FIG. 1 illustrates a schematic block diagram of exemplary components in an embodiment of the biosensor 100. The biosensor 100 may include one or more processing circuits 102 communicatively coupled to a memory device 104. In one aspect, the memory device 104 may include one or more non-transitory processor readable memories that store instructions which when executed by the one or more processing circuits 102, causes the one or more processing circuits 102 to perform one or more functions described herein. The processing circuit 102 may be co-located with one or more of the other circuits of the biosensor 100 in a same physical circuit board or located separately in a different circuit board or encasement. The processing circuit 102 may also be communicatively coupled wirelessly or wired to a user device, central control module and/or server. The memory device may store motion patterns 106 and/or PPG data 108 obtained by the biosensor 100.

[0066] The biosensor 100 may include a temperature sensor 114 configured to detect a temperature of a user. For example, the temperature sensor 114 may include an array of sensors (e.g., 16x16 pixels) to detect a temperature of skin tissue of a user. The temperature sensor 114 may be used to calibrate the PPG circuit 110. The biosensor 100 may include a display 116 to display biosensor data or a control user interface for the biosensor 100.

[0067] The biosensor 100 further includes a transceiver 112. The transceiver 112 may include a wireless or wired transceiver configured to communicate with or with one or more devices over a LAN, MAN and/or WAN. In one aspect, the wireless transceiver may include a Bluetooth enabled (BLE) transceiver or IEEE 802.11ah, Zigbee, IEEE 802.15-11 or WLAN (such as an IEEE 802.11 standard protocol)

compliant transceiver. In another aspect, the wireless transceiver may operate using RFID, short range radio frequency, infrared link, or other short range wireless communication protocol. In another aspect, the wireless transceiver may also include or alternatively include an interface for communicating over a cellular network. The transceiver **112** may also include a wired transceiver interface, e.g., a USB port or other type of wired connection, for communication with one or more other devices over a LAN, MAN and/or WAN. The transceiver **112** may include a wireless or wired transceiver configured to communicate with a vehicle or its components over a controller area network (CAN), Local Interconnect Network (LIN), Flex Ray, Media Oriented Systems Transport (MOST), (On-Board Diagnostics II), Ethernet or using another type of network or protocol. The biosensor **100** may transmit using the transceiver **112** over a wide area network, such as a cellular network, to a third party service provider, such as a health care provider or emergency service provider, or to a remote user device. The biosensor **100** may be battery operated and include a battery **118**, such as a lithium ion battery.

**[0068]** The biosensor **100** may further include one or more motion sensors **120**. For example, motion sensors **120** may include a gyroscope **122** and/or an accelerometer **124** or other motion sensing device. For example, the accelerometer **124** may be a three-axis accelerometer that measures linear acceleration in up to three-dimensions (for example, x-axis, y-axis, and z-axis). The gyroscope **122** may be a three-axis gyroscope that measures rotational data, such as rotational movement and/or angular velocity, in up to three-dimensions (for example, yaw, pitch, and roll). In some embodiments, accelerometer **124** may be a microelectromechanical system (MEMS) accelerometer, and gyroscope **122** may be an MEMS gyroscope. The processing circuit **102** may receive motion sensor data from the gyroscope **122** or accelerometer **124** to track acceleration, rotation, position, or orientation information of the biosensor **100** in six degrees of freedom through three-dimensional space. The motion sensor may thus provide motion data relating to movement of the biosensor in three-dimensional (3D) space in relation to a portion of the user or to a control plane.

**[0069]** In some embodiments, the biosensor **100** may include other types of sensors in addition to the gyroscope **122** or accelerometer **124**. For example, the biosensor **100** may include an altimeter or barometer, or other types of location sensors, such as a GPS sensor. The motion sensors **120** are configured to detect movement and direction of movement, e.g. with respect to a reference plane or a portion of the user. The biosensor **100** may be implemented in a watch, in a patch, in a band, in an earpiece, in a helmet, in a headband, necklace, or in other form factors. The biosensor **100** is positioned adjacent to the skin on an arm, wrist, hand, ankle, foot, or other body part.

#### Embodiment—PPG Circuit

**[0070]** FIG. 2 illustrates a schematic block diagram of an embodiment of the PPG circuit **110** in more detail. The PPG circuit **110** includes a light source **210** configured to emit a plurality of wavelengths of light across various spectrums. The plurality of LEDs **212a-n** are configured to emit light in one or more spectrums, including infrared (IR) light, ultraviolet (UV) light, near IR light or visible light, in response to driver circuit **218**. For example, the biosensor **100** may include a first LED **212a** that emits visible light and a second

LED **212b** that emits infrared light and a third LED **212c** that emits UV light, etc. In another embodiment, one or more of the light sources **212a-n** may include tunable LEDs or lasers operable to emit light over one or more frequencies or ranges of frequencies or spectrums in response to driver circuit **218**. **[0071]** In an embodiment, the driver circuit **218** is configured to control the one or more LEDs **212a-n** to generate light at one or more frequencies for predetermined periods of time. The driver circuit **218** may control the LEDs **212a-n** to operate concurrently or consecutively. The driver circuit **218** is configured to control a power level, emission period and frequency of emission of the LEDs **212a-n**. The biosensor **100** is thus configured to emit one or more wavelengths of light in one or more spectrums that is directed at the surface or epidermal layer of the skin tissue of a user. The emitted light **216** passes through at least one aperture **214** directed at the surface or epidermal layer of the skin tissue of a user.

**[0072]** The PPG circuit **110** further includes one or more photodetector circuits **230a-n**. The photodetector circuits **230** may be implemented as part of a camera **250**. For example, a first photodetector circuit **230** may be configured to detect visible light and the second photodetector circuit **230** may be configured to detect IR light. Alternatively, one or more of the photodetectors **230a-n** may be configured to detect light across multiple spectrums. When multiple photodetectors **230** are implemented, the detected signals obtained from each of the photodetectors may be added or averaged. Alternatively, a detected light signal with more optimal signal to noise ratio may be selected from the multiple photodetector circuits **230a-n**.

**[0073]** The first photodetector circuit **230** and the second photodetector circuit **230** may also include a first filter **260** and a second filter **262** configured to filter ambient light and/or scattered light. For example, in some embodiments, only light reflected at an approximately perpendicular angle to the skin surface of the user is desired to pass through the filters. The first photodetector circuit **230** and the second photodetector circuit **230n** are coupled to a first A/D circuit **238a** and a second A/D circuit **238b**. Alternatively, a single A/D circuit **238** may be coupled to each of the photodetector circuits **230a-n**.

**[0074]** In another embodiment, a single photodetector circuit **230** may be implemented operable to detect light over multiple spectrums or frequency ranges. The one or more photodetector circuits **230** include one or more types of spectrometers or photodiodes or other type of circuit configured to detect an intensity of light as a function of wavelength to obtain a spectral response. In use, the one or more photodetector circuits **230** detect the intensity of reflected light **240** from skin tissue of a user that enters one or more apertures **220a-n** of the biosensor **100**. In another example, the one or more photodetector circuits **230** detect the intensity of light due to transmissive absorption (e.g., light transmitted through tissues, such as a fingertip or ear lobe). The one or more photodetector circuits **230a-n** then obtain a spectral response of the reflected or transmissive light by measuring an intensity of the light at one or more wavelengths.

**[0075]** In another embodiment, the light source **210** may include a broad spectrum light source, such as a white light to infrared (IR) or near IR LED, that emits light with wavelengths across multiple spectrums, e.g. from 350 nm to 2500 nm. Broad spectrum light sources with different ranges

may be implemented. In an aspect, a broad spectrum light source is implemented with a range across 100 nm wavelengths to 2000 nm range of wavelengths in the visible, IR and/or UV frequencies. For example, a broadband tungsten light source for spectroscopy may be used. The spectral response of the reflected light **240** is then measured across the wavelengths in the broad spectrum, e.g. from 350 nm to 2500 nm, concurrently. In an aspect, a charge coupled device (CCD) spectrometer may be configured in the photodetector circuit **230** to measure the spectral response of the detected light over the broad spectrum.

[0076] The PPG circuit **110** may also include a digital signal processing (DSP) circuit or filters or amplifiers to process the spectral data. The spectral data may then be processed by the processing circuit **102** to obtain health data of a user. The spectral data may alternatively or in additionally be transmitted by the biosensor **100** to a central control module for processing to obtain health data of a user.

[0077] FIG. 3 illustrates a schematic block diagram of another embodiment of a PPG circuit **110** implemented within a camera **300**. In an embodiment, the camera includes a light source **302** configured to emit light in one or more of the visible, IR and/or UV spectrum. In one embodiment, an optical driver **304** is configured to control the light source **302**. In a health monitoring mode, the optical driver **304** controls the light source to emit light at predetermined wavelengths to detect health data. The health data may include one or more of: heart rate, respiration rate, heart rate variability, vasodilation, etc. The health data may also include concentration levels of substances in blood flow such as SpO<sub>2</sub>, nitric oxide (NO), liver enzymes such as P450, or other blood substances. The camera **300** further includes an image sensor **306** (such as a photodetector) that is sensitive to UV, visible and/or IR light. A digital signal processing (DSP) device **308** receives the pixel intensity levels for an array of pixels (such as 1024×1068) at each channel (RGB, IR, UV, etc.) for each frame. For example, in a motion detection or a health monitoring mode, the image sensor **306** and DSP device **308** process IR and UV channels as well as RGB channels. The UV and IR light may be filtered when not in a health monitoring mode or motion detection mode. A memory card **1210** stores the image data for each frame. A processing device **312** is configured to process the image data for the frames to determine PPG signals at one or more wavelengths. In another embodiment, the image data may be transmitted to another control module for analysis. The camera **300** may be implemented in a user device, such as a smart phone, laptop, smart tablet, watch, bracelet, button, webcam, video camera in a vehicle, etc.

[0078] In an embodiment herein, detection of light in UV range may be implemented in the camera, e.g. from ambient light or a custom LED. Derivation of a PPG signal from light reflected in the UV range from a body part has been found to have advantages over light in the visible and IR range. For example, UV light reflected from a face may be used to derive a PPG signal. The UV light provides an improved PPG signal for detection of heart rate, respiration rate, SpO<sub>2</sub> and nitric oxide (NO) levels as well as motion detection.

#### Embodiment—Motion Detection Using a PPG Signal

[0079] In one aspect, the biosensor **100** receives reflected light or transmissive light from skin tissue to obtain a spectral response, e.g. a PPG signal, around a wavelength.

The spectral response includes a spectral curve that illustrates an intensity or power or energy at the wavelength in a spectral region of the detected light. Pattern classification and recognition algorithms are used in conjunction with predetermined PPG patterns to obtain motion data, e.g. an identification of a moving body part and type of motion of the body part. For example, a first PPG pattern may correspond to a rotation of a hand while a second PPG pattern may correspond to a vertical movement of an index finger. One or more of the predetermined PPG patterns are recognized in the detected PPG signal. The moving body part and the type of movement (horizontal, vertical, extension, retraction, rotation) are then identified to generate motion data. Control commands may be mapped to the motion data to generate an input to a device.

[0080] FIG. 4 illustrates a logical flow diagram of an embodiment of a method **400** for motion detection using a PPG signal. The biosensor **100** transmits light around a first wavelength from a light source at a first location. The biosensor **100** detects the light (reflected from the skin or transmitted through the skin) and determines a PPG signal at the first wavelength at **402**.

[0081] Photoplethysmography (PPG) is used to measure time-dependent volumetric properties of blood in blood vessels due to the cardiac cycle. For example, the heartbeat generates a pressure pulse that affects the volume of blood flow and the vasodilation of vessels. For example, incident light  $I_o$  is directed at a tissue site at one or more wavelengths. The reflected/transmitted light  $I$  is detected by a photodetector or sensor array in a camera. At a peak of blood flow or volume, the reflected light  $I_r$  **414** is at a minimum due to absorption by the pulsating blood, non-pulsating blood, other tissue, etc. At a minimum of blood flow or volume during the cardiac cycle, the Incident or reflected light  $I_r$  **416** is at a maximum due to lack of absorption from the pulsating blood volume. Since the light  $I$  is reflected or traverses through a different volume of blood at the two measurement times, the measurement provided by a PPG sensor is said to be a ‘volumetric measurement’ descriptive of the differential volumes of blood present at a certain location within the user’s vessels at different times during the cardiac cycle. These principles described herein may be applied to venous blood flow and arterial blood flow.

[0082] In addition to the time-dependent volumetric properties of blood in blood vessels due to the cardiac cycle, the PPG signal also reflects movement due to changing optical properties of the underlying tissue and motion artifacts. Even with minimal or no movement, a neural stimulation affects vasodilation of surrounding vessels that may be detected by the PPG signal. Digital signal processing may be performed on the PPG signal, such as amplification, filtering of heart rate or respiration rate, etc. For example, responses in the PPG signals greater than a 10 Hz rate of the typical cardiac cycle may be due to neural activity.

[0083] The moving body part and the type of movement (horizontal, vertical, extension, retraction, rotation) are then identified to generate motion data at **404**. Pattern classification and recognition algorithms may be used in conjunction with predetermined PPG patterns to obtain the motion data. Alternatively, a neural network or Artificial Intelligence (AI) device may be used to analyze the PPG signal using training vectors to determine the motion data.

[0084] Control commands may be mapped to the motion data to generate an input to a device at **406**. For example, a

corresponding hand gestures or finger movements may be mapped into various control commands to achieve a conventional input similar to a mouse, a keyboard, a touch screen, etc. The control commands may be used as inputs to any type of electronic device, such as a smart watch, phone, glasses, earbuds, tablet, laptop, television, IoT device, manned or unmanned vehicle, a medical device, such as an artificial limb or wheelchair, etc.

[0085] FIG. 5-11 are provided herein to show an example of the PPG signals during no movement and movement of various body parts. The examples illustrate the replicative PPG patterns due to a movement.

[0086] FIG. 5 illustrates a schematic diagram of a graph 500 of spectral responses obtained using an embodiment of the biosensor 100 during a period of little to no motion. In this embodiment, the biosensor 100 is positioned on a wrist of a right hand of a user, as shown in further detail with respect to FIG. 29. In one aspect, the biosensor 100 is configured to emit or pulse light at a plurality of wavelengths during a measurement period. The light at each wavelength (or range of wavelengths) may be emitted concurrently or sequentially. The intensity of the reflected light at each of the wavelengths (or range of wavelengths) is detected, and a graph 500 of the spectral responses is shown over the measurement period. In this example, the PPG signals at the plurality of wavelengths were obtained concurrently during a period of little to no motion of the wrist, hand and fingers.

[0087] In this example, the biosensor 100 obtained a PPG signal around a wavelength at 940 nm, a wavelength at 880 nm and a wavelength at 660 nm 412 as shown in the PPG Signals for Wavelength Group 502a. The biosensor 100 also obtained the spectral response for a wavelength at 590 nm, a wavelength at 530 nm and a wavelength at 470 nm as shown in the PPG Signals for Wavelength Group 502b. The biosensor 100 further obtained the spectral response for a wavelength at 405 nm, a wavelength at 400 nm and a wavelength at 395 nm as shown in the PPG Signals for Wavelength Group 502c.

[0088] The PPG signals at the plurality of wavelengths include a response to the pressure pulse wave through the vessels from the cardiac cycle. There is little to no indication of movement of the hand or fingers in the PPG signals.

[0089] FIG. 6 illustrates a schematic diagram of a graph 600 of spectral responses obtained using an embodiment of the biosensor 100 during movement of a thumb on a right hand of the user. The biosensor 100 is still positioned on the wrist of the right hand of the user and has not been repositioned. During this measurement period, the thumb on the right hand is moved.

[0090] Again, in this example, the biosensor 100 obtained a PPG signal around a wavelength at 940 nm, a wavelength at 880 nm and a wavelength at 660 nm 412 as shown in the PPG Signals for Wavelength Group 602a. The biosensor 100 also obtained the spectral response for a wavelength at 590 nm, a wavelength at 530 nm and a wavelength at 470 nm as shown in the PPG Signals for Wavelength Group 602b. The biosensor 100 further obtained the spectral response for a wavelength at 405 nm, a wavelength at 400 nm and a wavelength at 395 nm as shown in the PPG Signals for Wavelength Group 602c.

[0091] The PPG signals at the plurality of wavelengths include a response to the pressure pulse wave through the vessels from the cardiac cycle. In addition, at approximately the time of 14.23.54 seconds, there is an indication of

movement of the thumb in the PPG signals as shown in responses 604a-c. The PPG signals at each wavelength have a similar pattern in response to the movement of the thumb, though the pattern 604a in the wavelength group 602a is inverted in this graph. For example, the pattern of the response 604a is similar to the pattern of the response 604b and the pattern of the response at 604c. These patterns 604a-c in the PPG signal are not present in the PPG signals with little to no movement shown in FIG. 5.

[0092] FIG. 7 illustrates a schematic diagram of a graph 700 of spectral responses obtained using an embodiment of the biosensor 100 during movement of an index finger on a right hand of the user. The biosensor 100 is still positioned on the wrist of the right hand of the user and has not been repositioned. During this measurement period, the index finger on the right hand is moved.

[0093] Again, in this example, the biosensor 100 obtained a PPG signal around a wavelength at 940 nm, a wavelength at 880 nm and a wavelength at 660 nm as shown in the PPG Signals for Wavelength Group 702a. The biosensor 100 also obtained the spectral response for a wavelength at 590 nm, a wavelength at 530 nm and a wavelength at 470 nm as shown in the PPG Signals for Wavelength Group 702b. The biosensor 100 further obtained the spectral response for a wavelength at 405 nm, a wavelength at 400 nm and a wavelength at 395 nm as shown in the PPG Signals for Wavelength Group 702c.

[0094] The PPG signals at the plurality of wavelengths include a response to the pressure pulse wave through the vessels from the cardiac cycle. In addition, at approximately the time of 14.25.21, there is an indication of movement of the index finger in the PPG signals. The PPG signals at each wavelength have a similar pattern in response to the movement of the index finger, though the pattern 704c is less defined at the lower wavelengths in wavelength group 702c. These patterns 704a-c in the PPG signal are not present in the PPG signals with little to no movement shown in FIG. 5. In addition, these patterns 704a-c are different from the patterns 604a-c in the PPG signals due to movement of the thumb shown in FIG. 6.

[0095] FIG. 8 illustrates a schematic diagram of a graph 800 of spectral responses obtained using an embodiment of the biosensor 100 during movement of a middle finger on a right hand of the user. The biosensor 100 is still positioned on the wrist of the right hand of the user and has not been repositioned. During this measurement period, the middle finger on the right hand is moved.

[0096] Again, in this example, the biosensor 100 obtained a PPG signal around a wavelength at 940 nm, a wavelength at 880 nm and a wavelength at 660 nm as shown in the PPG Signals for Wavelength Group 802a. The biosensor 100 also obtained the spectral response for a wavelength at 590 nm, a wavelength at 530 nm and a wavelength at 470 nm as shown in the PPG Signals for Wavelength Group 802b. The biosensor 100 further obtained the spectral response for a wavelength at 405 nm, a wavelength at 400 nm and a wavelength at 395 nm as shown in the PPG Signals for Wavelength Group 802c.

[0097] The PPG signals at the plurality of wavelengths include a response to the pressure pulse wave through the vessels from the cardiac cycle. In addition, at approximately the time of 14.26.56, there is an indication of movement of the middle finger in the PPG signals. The PPG signals at each wavelength have a similar pattern in response to the

movement of the middle finger. These patterns **804a-c** in the PPG signal are not present in the PPG signals with little to no movement shown in FIG. 5. In addition, these patterns **804a-c** are different from the patterns **604a-c** in the PPG signals due to movement of the thumb shown in FIG. 6 and from the patterns **704a-c** in the PPG signals due to movement of the index finger shown in FIG. 7.

[0098] FIG. 9 illustrates a schematic diagram of a graph **900** of spectral responses obtained using an embodiment of the biosensor **100** during movement of a fourth finger on a right hand of the user. The biosensor **100** is still positioned on the wrist of the right hand of the user and has not been repositioned. During this measurement period, the fourth finger on the right hand is moved.

[0099] Again, in this example, the biosensor **100** obtained a PPG signal around a wavelength at 940 nm, a wavelength at 880 nm and a wavelength at 660 nm as shown in the PPG Signals for Wavelength Group **902a**. The biosensor **100** also obtained the spectral response for a wavelength at 590 nm, a wavelength at 530 nm and a wavelength at 470 nm as shown in the PPG Signals for Wavelength Group **902b**. The biosensor **100** further obtained the spectral response for a wavelength at 405 nm, a wavelength at 400 nm and a wavelength at 395 nm as shown in the PPG Signals for Wavelength Group **902c**.

[0100] The PPG signals at the plurality of wavelengths include a response to the pressure pulse wave through the vessels from the cardiac cycle. In addition, at approximately the time of 14.28.51, there is an indication of movement of the fourth finger in the PPG signals. The PPG signals at each wavelength have a similar pattern **904a**, **904b**, **904c** in response to the movement of the fourth finger. These patterns **904a-c** in the PPG signal are not present in the PPG signals with little to no movement shown in FIG. 5. In addition, these patterns **904a-c** are different from the patterns **604a-c** in the PPG signals due to movement of the thumb shown in FIG. 6 and from the patterns **704a-c** in the PPG signals due to movement of the index finger shown in FIG. 7 and from the patterns **804a-c** in the PPG signals due to movement of the middle finger shown in FIG. 8.

[0101] FIG. 10 illustrates a schematic diagram of a graph **1000** of spectral responses obtained using an embodiment of the biosensor **100** during movement of a fifth finger on a right hand of the user. The biosensor **100** is still positioned on the wrist of the right hand of the user and has not been repositioned. During this measurement period, the fifth finger on the right hand is moved.

[0102] Again, in this example, the biosensor **100** obtained a PPG signal around a wavelength at 940 nm, a wavelength at 880 nm and a wavelength at 660 nm as shown in the PPG Signals for Wavelength Group **1002a**. The biosensor **100** also obtained the spectral response for a wavelength at 590 nm, a wavelength at 530 nm and a wavelength at 470 nm as shown in the PPG Signals for Wavelength Group **1002b**. The biosensor **100** further obtained the spectral response for a wavelength at 405 nm, a wavelength at 400 nm and a wavelength at 395 nm as shown in the PPG Signals for Wavelength Group **1002c**.

[0103] The PPG signals at the plurality of wavelengths include a response to the pressure pulse wave through the vessels from the cardiac cycle. In addition, at approximately the time of 14.31.40, there is an indication of movement of the fifth finger in the PPG signals. The PPG signals at each wavelength have a similar pattern **1004a**, **1004b**, **1004c** in

response to the movement of the fifth finger. These patterns **1004a-c** in the PPG signal are not present in the PPG signals with little to no movement shown in FIG. 5. In addition, these patterns **1004a-c** are different from the patterns **604a-c** in the PPG signals due to movement of the thumb shown in FIG. 6 and from the patterns **704a-c** in the PPG signals due to movement of the index finger shown in FIG. 7 and from the patterns **804a-c** in the PPG signals due to movement of the middle finger shown in FIG. 8 and from the patterns **904a-c** in the PPG signals due to the movement of the fourth finger shown in FIG. 9.

[0104] FIG. 11 illustrates a schematic diagram of a comparison of PPG signals obtained during movement of the fingers on the right hand. The graphs **1100a-e** illustrate the unique patterns in the PPG signal due to movement of the different fingers. The graphs **1100a-e** provide a comparison of the PPG signal patterns and that the PPG signal patterns are unique and reproducible across a plurality of wavelengths.

[0105] The pattern in the PPG signal varies depending on the finger with movement. The PPG signal detected at the various wavelengths illustrate a unique pattern. Thus, the PPG signal at one or more wavelengths may be used to detect movement and determine a body part that is moving (e.g., identify one of the fingers that is moving). The PPG signals detected by the plurality of the LEDs may each be considered to determine a motion vector of a body part. For example, as shown in FIG. 11, different wavelengths may have unique PPG signal patterns for movement of a body part. The PPG pattern **704a** due the movement of the index finger at 940 nm is different than the PPG pattern due to the movement of the index finger at 395 nm. The unique patterns at each of a plurality of wavelengths may be considered or at only a single wavelength.

[0106] Though the PPG signal was obtained by a biosensor **100** at a wrist, the PPG circuit may be positioned on the hand or above the wrist as well to detect movement and identify the specific finger that is moving. The PPG signal patterns at one or more wavelengths may thus be used to detect movement and identify the moving body part.

[0107] In addition, the PPG signal patterns vary depending on the type of movement of a body part. For example, when the index finger moves vertically up and down, a first PPG signal pattern is generated. When the index finger is retracted and extended, a second, different signal pattern is generated. The PPG signal pattern may thus be used to identify a motion vector or type of movement as well as identify the moving body part.

[0108] When we physically move our body parts, the PPG signal motion artifacts are due to neural activity (seen especially at initiation of the motion artifact), vasodilation, movement of tissue, and color hue changes due to movement/vasodilation, as explained in more detail herein. Different movements create different changes in the neural activity, vasodilation, tissue movement and color hue. As such unique PPG signal patterns are generated for different movements of a same body part. Similarly, unique PPG signal patterns are generated for a same movement of different body parts.

[0109] The biosensor may be placed on other body parts and the PPG signal may be obtained at the other body parts to detect motion data. For example, a PPG signal may be obtained from an ankle or foot region to detect movement of the foot or toes. A PPG signal may be obtained from an ear

bud or glasses to detect facial movements. A biosensor implemented on a patch may be placed on any region of the body to detect movement, type of movement and identify the moving body part.

[0110] FIG. 12 illustrates a logical flow diagram of an embodiment of a method 1200 for obtaining motion data by the biosensor 100. In one aspect, the biosensor 100 emits and detects light at a plurality of predetermined frequencies or wavelengths, such as approximately 940 nm, 660 nm, 390 nm, 592 nm, and 468 nm or in ranges thereof. The light is pulsed for a predetermined period of time (such as 100 usec or 200 Hz) sequentially or simultaneously at each predetermined wavelength. In another aspect, light may be pulsed in a wavelength range of 1 nm to 50 nm around each of the predetermined wavelengths. For example, for the predetermined wavelength 390 nm, the biosensor 100 may transmit light directed at skin tissue of the user in a range of 360 nm to 410 nm including the predetermined wavelength 390 nm. For the predetermined wavelength of 940 nm, the biosensor 100 may transmit light directed at the skin tissue of the user in a range of 920 nm to 975 nm. In another embodiment, the light is pulsed simultaneously at least at each of the predetermined wavelengths (and in a range around the wavelengths).

[0111] The spectral responses are obtained around the plurality of wavelengths. This measurement process is repeated continuously, e.g., pulsing the light at 10-100 Hz and obtaining spectral responses over a desired measurement period for detection of motion. The spectral data obtained by the PPG circuit 110, such as the digital or analog spectral responses, may be processed locally by the biosensor 100 or transmitted to a central control module for processing. For example, the PPG circuit may be positioned on the skin and the PPG signals transmitted to a cell phone or other user device for processing.

[0112] The PPG signals are detected at one or more wavelengths and signal processing performed at 1202. During signal processing, the components of the PPG signal due to the cardiac cycle and respiration rate may be filtered. For example, the PPG signal at a wavelength when no motion is detected (as shown in FIG. 5) may be obtained. This PPG signal may then be filtered from subsequent PPG signals at the same wavelength.

[0113] This signal processing thus helps to isolate the motion artifacts in the PPG signal. The PPG signal patterns due to motion artifacts may have various causes. For example, the motion artifacts may be generated in response to a change in underlying tissue characteristics due to the moving tissue, changes in vasodilation due to neural stimulation or increased blood flow to the region.

[0114] The motion artifacts in the PPG signal at one or more wavelengths are compared and correlated to one or more of the predetermined PPG signal patterns for the one or more wavelengths at 1204. Pattern classification and recognition algorithms are used in conjunction with the predetermined PPG signal patterns. The PPG signals detected by a plurality of the LEDs may each be considered to determine a motion vector of a body part. For example, as shown in FIG. 11, different wavelengths may have unique PPG signal patterns for movement of a body part. The PPG pattern 704a due the movement of the index finger at 940 nm is different than the PPG pattern due to the movement of the index finger at 395 nm. A first PPG pattern at a first wavelength may correspond to a rotation of a hand while a

second PPG pattern at a second wavelength may correspond to the same rotation of the hand. As such, for a more accurate detection of a motion vector, the PPG signals at a plurality of wavelengths may be analyzed to detect the unique PPG pattern for that wavelength.

[0115] In addition, a unique pattern is generated at a wavelength for movement of different body parts and different motion vectors or types of movement. For example, movement of the index finger creates a different unique pattern at a wavelength (such as 940 nm) from movement of the thumb or pinkie at the same wavelength (such as 940 nm). Unique PPG signal patterns at one or more wavelengths may be stored in a database with corresponding motion data of a body part. The motion data may include a type of movement (clenched fist, extension or retraction of finger), a motion vector (direction, speed, acceleration), etc. The PPG signal patterns at multiple wavelengths may be obtained and the corresponding motion data compared for verification.

[0116] One or more of the predetermined PPG signal patterns are recognized in the detected PPG signal. The PPG signal patterns are mapped to a moving body part as shown in FIG. 11 and may be mapped to a motion vector of a body part. For example, the motion artifact may be used to determine an acceleration of the motion or to determine a speed and direction of the movement of the body part. Thus, the motion data may include an identification of the moving body part and the type of movement (horizontal, vertical, extension, retraction, rotation, etc.) and motion vector, e.g. acceleration (speed and/or direction) data representative of an acceleration proximate to a portion of the user at 1206.

[0117] The PPG signal pattern or motion artifact is due to changes in optical properties of the underlying tissue. The changes may be due to one or more of neural activity, vasodilation of vessels, expansion and contraction of tissue (muscle skin), or change in hue of skin due to such expansion and contraction. A correlation of the motion induced artifact in the PPG signal to a corresponding muscular position may thus be performed. A DC level of the PPG signal or maximum amplitude of the motion artifact may also be measured to determine a force of the motion. Since neural activity/activation begins prior to vasodilation and muscle movement, the neural activity is superimposed on the PPG signal and is most visible at initiation of the motion artifact.

[0118] In addition to PPG signal patterns, the PPG signals may be analyzed to determine other metrics for obtaining the motion data. For example, the PPG signals may be used to determine a DC level, amplitude levels, a heart rate, respiration rate, or level of vasodilation. One or more of these metrics may also be used to obtain the motion data as well.

[0119] Control commands may be generated in response to the motion data for input to a device at 1208. The motion data may be mapped to predetermined control commands or the control commands may be determined based on a Graphical User Interface (GUI) and motion data. For example, the motion data may be used to operate a user device, such as a smart watch, smart glasses, laptop, smart tablet, smart phone, etc. The fingers may be moved to indicate typing on a virtual keyboard. Or the fingers may be moved to select icons on a GUI or move a cursor on a display without having to touch the display or device. Thus, a typical input device, such as a mouse, touchpad, keyboard,

touchscreen or joystick, may be replaced using the motion detection of the biosensor **100**.

[0120] The biosensor **100** may thus be used to operate a user device, such as a smart watch or smart glasses, that may otherwise be difficult to operate through a touchscreen. In one aspect, the biosensor **100** may be used to control a drone or other vehicle. The drone may be controlled intuitively by moving a hand up or down to control altitude or rotating the hand to control direction and tilt of the drone. A speed of the drone may be controlled by acceleration of the movements. The biosensor **100** using movement recognition may thus be used for providing instructions and control of a many different types of user devices or any type of electronic system needing man-machine interaction.

[0121] In another embodiment, the biosensor **100** may detect motion data relating to sign language. A biosensor **100** may be placed on both wrists of a user to determine movement and gestures of a user using PPG signals and the motion sensor. These movements may be translated to sign language, and the corresponding words reproduced to a word processing application. Thus, a person may “dictate” using sign language to the word processing application. The translation of sign language to written word using the biosensor **100** may also be used in communication applications or for translators.

#### Embodiment—Measuring a Level of Vasodilation

[0122] Vasodilation changes the way that the pressure wave in blood flow from the heart beat impulse propagates from the deeper, larger arteries to the shallower, smaller ones. In an embodiment described herein, this change in propagation of the pressure wave can be measured in the change in transfer function from a wavelength in the near-IR window, which penetrates the tissue deeply, to a wavelength not in the near-IR window, which penetrates tissue much less deeply. This means that by measuring the change in shape and time delay of PPG signals of two or more wavelengths, where at least one is in the near-IR window and one is not, information about vasodilation may be determined. Also, because the transfer function between the two depths of penetration is affected by blood pressure, blood viscosity, tissue absorption, and, in general, cardiovascular health, these other parameters can be characterized as well. Features or parameters of the PPG signal that can be examined to obtain a level of vasodilation include, but are not limited to, the time delay between the systolic points and diastolic points in different wavelengths and the difference in dichroic notch suppression between wavelengths.

[0123] FIG. 13 illustrates a schematic diagram of a graph **1300** of PPG signals during a period of vasodilation in vessels. At “rest”, a body responds to caloric intake and vasodilation occurs normally as the body processes food, insulin is dispensed, and arteries expand due to Nitric Oxide (NO) causing the outer muscle of the arteries to expand temporarily. This vasodilation is reflected in the PPG signal, and highly visible in the signal to noise ratio.

[0124] The biosensor **100** obtained a PPG signal during vasodilation after caloric intake around a wavelength at 940 nm, a wavelength at 880 nm and a wavelength at 660 nm as shown in the PPG Signals for Wavelength Group **1302a**. The biosensor **100** also obtained the spectral response for a wavelength at 590 nm, a wavelength at 530 nm and a wavelength at 470 nm as shown in the PPG Signals for Wavelength Group **1302b**. The biosensor **100** further

obtained the spectral response for a wavelength at 405 nm, a wavelength at 400 nm and a wavelength at 395 nm as shown in the PPG Signals for Wavelength Group **1302c**.

[0125] As shown in the graphs, the PPG signals reflect a period of vasodilation **1304a**, **1304b**, **1304c** of vessels. The vasodilation **1304a-c** is reflected in the PPG signals during a time period between approximately **16.11.04** secs through approximately **16.11.17** secs. In particular, a lower frequency component of the PPG signals changes during the period of vasodilation **1304a-c**. This lower frequency component of the PPG signals includes the lower frequencies not affected by the pulsating blood flow (pressure wave) due to the cardiac cycle.

[0126] During vasodilation, the arteries and other vessels widen changing the absorption properties of the vascular tissue. These changes in absorption properties are due, e.g., by the increase in blood in the vascular tissue and the compression of surrounding tissue due to the widening vessels. The PPG signals across wavelengths in the IR, visible and UV spectrums are affected by the changing absorption properties of the vascular tissue due to vasodilation.

[0127] The duration of the period of vasodilation and/or the intensity change of the PPG signals during the period of vasodilation may be obtained. This vasodilation data from the PPG signal may be correlated to a level of vasodilation. For example, the level of vasodilation may be expressed as a percentage change of the diameter of the artery or percentage increase in blood flow.

[0128] FIG. 14 illustrates a schematic diagram of heart rate and lower frequency components of PPG signals during a period of vasodilation. The graph **1400** illustrates a heart rate obtained from higher frequency components of the PPG signals shown in FIG. 13. The spectral response may be filtered using digital signal processing techniques to eliminate noise and background interference to obtain a filtered spectral response. A heart rate may be determined from the spectral response. For example, the biosensor **100** may determine the time between diastolic points or between systolic points to determine a time period of a cardiac cycle. In another embodiment, to estimate the heart rate, the frequency spectrum of the PPG signal is obtained using a FFT algorithm over a predetermined period (hamming window). The pulse rate is estimated as the frequency that corresponds to the highest power in the estimated frequency spectrum. The frequency spectrum may be averaged or added over 5-10 second windows.

[0129] In addition, a respiration rate may be obtained by measuring a low frequency component of the filtered spectral response. From this low frequency component, the biosensor **100** may obtain a respiratory rate of a user from the spectral response.

[0130] The graph **1402** illustrates the lower frequency components (e.g. the frequencies not affected by pulsatile blood flow) of the PPG signals shown in FIG. 13 at 940 nm, 590 nm and 395 nm. The characteristics of the lower frequencies of the PPG signals change during the vasodilation period. The absorption properties of the vascular tissue vary due to changes in volume of blood and compression of tissue due to widening of the vessels.

[0131] In addition, the skin may expand in response to the widening vessels during vasodilation as reflected at **1404**. The lower frequencies not affected by pulsatile blood flow of the 590 nm signal shows the skin pigmentation being

slightly expanded. For example, the 590 nm (Yellow color) wavelength signal is a good signal to observe the melanin amount (pigment of skin). This change in skin hue due to expanding skin during vasodilation changes the absorption properties of the skin tissue around 590 nm. The PPG signals are thus affected by this change in absorption properties as seen in graph 1402.

[0132] The graph 1402 also illustrates that the PPG signals in different spectrums exhibit a time delay. For example, the PPG signal at 940 nm in the IR range, the PPG signal at 590 in the visible range, and the PPG signal at 395 in the UV range have timing differences. This time delay is due in part to the different penetration depths of the wavelengths.

[0133] The phase difference or the timing difference between PPG signals in different spectrums can be observed in similar fashion showing negative to positive timing which corresponds to the constrictions and expansion of the arteries. At a same input power, light at higher wavelengths (IR light) penetrates vascular tissue deeper than light at lower wavelengths (UV light). The optical properties of the tissue are affected by many factors, including but not limited to, skin-tone, tissue hydration, and tissue chemistry. In a sensor configuration where the light from the light source is back-scattered to a sensor on the same surface, the optical signal at the sensor includes a sum of all light backscattered that makes it to the focal surface after interacting with the tissue. With the optical power being the same across all wavelengths, some of the light backscattered from the IR light penetrates deeper into the tissue than the UV light does. This means that the different wavelengths of light probe different depths of tissue.

[0134] When the heart beats, the arteries swell as fluid is pushed out of the heart. The leading edge of the swelling or pressure wave moves like a “bulge” through the arterial system. This system can be thought of as an elastically dampened hydraulic system. The pressure wave or bulge in the pulsatile blood flow will move from the lower tissue to the upper tissue. Thus, the deeper penetrating wavelengths (such as IR light) will detect a pressure wave first followed by the lesser penetrating wavelengths (such as visible then UV light). The time delay in the “bulge” or pressure wave moving from the lower tissue into the upper tissue thus creates a time delay in a pressure waveform seen in the PPG signals at different wavelengths. For example, as seen in FIG. 13, a waveform in the UV range has a time delay compared to a waveform in the IR range and visible range. This time delay in the different wavelengths is thus due to the depth of penetration into the skin of each wavelength.

[0135] Vasodilation changes the propagation of the pressure wave from the deeper, larger arteries to the shallower, smaller ones. In an embodiment described herein, this change in propagation of the pressure wave can be measured in the change in transfer function from a wavelength that penetrates the tissue deeply (e.g. in the IR range) to a wavelength that penetrates tissue much less deeply (e.g. in the visible or UV range). This means that by measuring the change in shape and time delay of PPG signals of two or more wavelengths with different penetration depths (e.g., wherein at least one is in the near-IR window and one is not), information about vasodilation may be determined. Also, because the transfer function between the two depths of penetration is affected by blood pressure, blood viscosity, tissue absorption, and, in general, cardiovascular health, these other parameters can be characterized as well. Features

or parameters of the PPG signal that can be examined include, but are not limited to, the time delay between the systolic points and diastolic points in different wavelengths and the difference in diastolic notch suppression between wavelengths.

[0136] FIG. 15A and FIG. 15B illustrate schematic diagrams of graphs that illustrate time difference between PPG signals of various wavelengths during a period of vasodilation after caloric intake and a period with no vasodilation. FIG. 15A illustrates a schematic diagram of graphs of the phase difference of the PPG signals at different wavelengths during a period of vasodilation. In graph 1502, the phase difference is measured with respect to the PPG signal at 940 nm and so the phase delay shown is zero for 940 nm. The last shown phase difference is between PPG signals at 395 nm and 940 nm. The phase difference or the timing difference between PPG signals in graph 1502 illustrates a negative to positive timing which corresponds to the constrictions and expansion of the arteries during vasodilation. The phase delay between the PPG signals at different wavelengths is thus seen during a period of vasodilation.

[0137] The graph 1506 illustrates the average “DC values” in PPG signals of various wavelengths during the period of vasodilation. The “DC values”  $I_{DC}$  may include low frequencies not generally affected by the pulsatile blood flow. The graph 1506 illustrates that the average DC values  $I_{DC}$  are above a baseline normal during the period of vasodilation. The average DC values increase due to vasodilation, tissue characteristics of contracting or expanding muscles and is proportional to the force applied to the muscle. So, the DC value (low frequencies not generally affected by the pulsatile blood flow) can be used to determine a force applied during the movement.

[0138] FIG. 15B illustrates a graph 1506 of the average phase difference between waveforms in PPG signals of various wavelengths after the period of vasodilation. The phase difference is measured with respect to the PPG signal at 940 nm and so the phase delay shown is zero for 940 nm. The last shown time difference is between 395 nm and 940 nm. This graph 1506 illustrates that the baseline time differences return after the period of vasodilation. The change in phase difference between one or more different wavelengths may thus be used to determine a level of vasodilation and/or the period of vasodilation.

[0139] The graph 1508 illustrates the average DC values  $I_{DC}$  PPG signals of various wavelengths after the period of vasodilation. The DC values  $I_{DC}$  may include low frequencies not generally affected by the pulsatile blood flow. The graph 1508 illustrates that the average DC values  $I_{DC}$  return to a baseline normal after the period of vasodilation. The change in  $I_{DC}$  in one or more different wavelengths may thus be used to determine a level of vasodilation and/or the period of vasodilation. The U.S. Provisional Application No. 62/675,151 entitled, “SYSTEM AND METHOD OF A BIOSENSOR FOR DETECTION OF VASODILATION,” to Robert Newberry, filed May 22, 2018 provides additional details on measurement of a level of vasodilation and is hereby incorporated by reference herein.

[0140] Though these measurements in FIGS. 13-15 were obtained during rest after caloric intake, PPG signals after neural activation also reflect vasodilation. When a body part physically moves, the PPG signal motion artifacts are due to neural activity (at initiation), vasodilation, movement of

tissue, and color hue changes due to movement/vasodilation. These factors generate the unique signal patterns or motion artifacts in the PPG signals.

[0141] FIG. 16 illustrates a logical flow diagram of an embodiment of another method 1600 for obtaining motion data by the biosensor 100. The biosensor 100 transmits light at a plurality of discrete wavelengths at skin or living tissue of a user at 1602. Alternatively, the biosensor 100 may use a broad spectrum light source to emit light across one or more spectrums. The biosensor 100 detects light reflected from or transmitted through the tissue of the user and generates PPG signals at a plurality of wavelengths at 1604.

[0142] The biosensor 100 may use one or more types of data to detect motion and obtain motion data. For example, the biosensor 100 may process the PPG signals to obtain a level of vasodilation at 1606. The level of vasodilation may be indicative of movement or neural stimulation of a body part. The biosensor 100 may also obtain a heart rate, respiration rate and DC level from the PPG signals at 1608. The biosensor 100 may also analyze the PPG signals to identify any correlations with a PPG signal pattern indicating movement at one or more wavelengths at 1610. The biosensor 100 may also analyze the PPG signal pattern at visible light ranges (yellow, red) to determine any change in the skin color or hue at 1612.

[0143] The biosensor 100 may then obtain motion data using one or more of the identified PPG signal patterns in the PPG signals, the level of vasodilation, DC level, the heart rate, the respiration rate or skin color at 1614. The motion data obtained by multiple means may be compared for verification.

#### Embodiment—Neural Network for Motion Detection

[0144] In an embodiment, an artificial neural network may be implemented to process the PPG signal for detection of movement. For example, neural networks may be used to determine movement and direction of movement from input data. The input includes for example, the PPG signals at one or more wavelengths. Neural network models can be viewed as simple mathematical models defining a function  $f$  wherein  $f: X \rightarrow Y$  or a distribution over  $X$  or both  $X$  and  $Y$ . Types of neural network engines or APIs currently available include, e.g. TensorFlow™, Keras™, Microsoft® CNTK™, Caffe™, Theano™ and Lasagne™.

[0145] Sometimes the various machine learning techniques are intimately associated with a particular learning rule. The function  $f$  may be a definition of a class of functions (where members of the class are obtained by varying parameters, connection weights, thresholds, etc). The neural network learns by adjusting its parameters, weights and thresholds iteratively to yield desired output. The training is performed using defined set of rules also known as the learning algorithm. Machine learning techniques include ridge linear regression, a multilayer perceptron neural network, support vector machines and random forests. For example, a gradient descent training algorithm is used in case of supervised training model. In case, the actual output is different from target output, the difference or error is determined. The gradient descent algorithm changes the weights of the network in such a manner to minimize this error. Other learning algorithms include back propagation, least mean square (LMS) algorithm, etc. A set of examples

or a training set is used for learning by the neural network. The training set is used to identify the parameters [e.g., weights] of the network.

[0146] FIG. 17 illustrates a schematic block diagram of an embodiment of a neural network processing device 1700. The neural network processing device 1700 obtains or generates an input vector 1702. In this embodiment, the input vector includes at least one or more PPG signals at one or more wavelengths. The input vector may also include a position of the biosensor on the user (wrist, ankle, etc.), an identification of the wavelengths of the PPG signals, an intensity level of the LED light sources, etc. The input vector may also include motion sensor data from an accelerometer or gyroscope, such as direction and velocity of detected movement or a plane of the hand.

[0147] The neural network processing device 1700 may be pre-configured with weights, parameters or other learning vectors 1706 derived from a training set. The training set preferably included sets with the same type of information in the input vector and known movements of various body parts in various combinations. For example, the PPG signals may be obtained while various finger movements are made. This training set is provided to a neural network training algorithm to generate the learning vector 1706. The training set may include further motion sensor data as well as a position of the biosensor, a body part from which the PPG signal is obtained, an identification of the wavelength, etc.

[0148] The neural network processing device 1700 then obtains an output vector 1704. The output vector includes motion data, such as an identification of movement of a body part (such as Finger X), or a type of movement or a direction of movement or acceleration and speed of the movement.

[0149] FIG. 18 illustrates a logical flow diagram of an embodiment of a method 1800 for using machine learning techniques for motion detection using PPG signals at one or more wavelengths. PPG signals at one or more wavelengths are obtained at 1802. Various parameters of the PPG signals may be determined or measured. These parameters include the diastolic and systolic points, the L values, R values, pulse shape (measured by autoregression coefficients and moving averages), characteristic features of the shape of the PPG waveform, the average distance between pulses, variance, instant energy information, energy variance, etc. Other parameters may be extracted by representing the PPG signal as a stochastic auto-regressive moving average (ARMA). Parameters also may be extracted by modeling the energy of the PPG signal using the Teager-Kaiser operator, calculating the heart rate and cardiac synchrony of the PPG signal, and determining the zero crossings of the PPG signal. These and other parameters may be obtained from the one or more PPG signals and included as PPG input data.

[0150] An input vector is generated at 1804. The input vector includes the PPG input data, such as the PPG signals at one or more wavelengths and/or one or more parameters generated from the PPG signals at the one or more wavelengths. Since the PPG signal is of variable duration, a fixed dimension vector for a measurement of the PPG signal may be obtained. The input vector may also include motion sensor data.

[0151] The input vector is processed by a processing device executing a neural network (aka machine learning algorithm). The processing device executes the machine learning algorithm using the input vector at 1806 and determines motion data at 1808. The motion data includes

one or more of: identification of a moving body part, direction of movement, speed/acceleration of movement, etc. The direction of the movement may be identified with respect to an identified plane or with respect to another body part. The obtained motion data may then be used to control a device at **1810**.

**[0152]** FIG. **19** illustrates a logical flow diagram of an embodiment of a method **1900** of generating a learning vector **1706** from a training set. During a learning stage, a neural network adjusts parameters, weights and thresholds iteratively to yield a known output vector from an associated input vector. The training is performed using defined set of rules also known as the learning algorithm. For example, a gradient descent training algorithm is used in case of supervised training model. In case, the actual output is different from target output, the difference or error is determined. The gradient descent algorithm changes the weights of the network in such a manner to minimize this error. Other learning algorithms include back propagation, least mean square (LMS) algorithm, etc. A set of examples or a training set is used for learning by the neural network. The training set is used to identify the parameters [e.g., weights] of the neural network.

**[0153]** The input vectors and known output vectors are included in the training set. In an embodiment, the training set is obtained in a clinical setting. For example, a biosensor or non-contact camera obtains one or more PPG signals of a body part. The body part is moved in a measured direction at a measured speed. Accelerometer data may also be obtained. The PPG input data and accelerometer data are thus obtained with known motion data at **1902**.

**[0154]** The PPG input data is determined from the PPG signals, as described hereinabove. The input vector is then derived from the PPG input data and motion sensor data. The output vector is also generated from the motion data. The training set preferably includes a plurality of input vectors and corresponding output vectors. In an embodiment, the training is performed for each individual user. In another embodiment, training is performed from measurements of a general population.

**[0155]** The training set is processed at **1906** using a learning algorithm for a neural network. The neural network determines a learning vector, e.g. processing parameters. The estimator function system may work blindly, in the sense that no functional restriction is imposed on the relationship between the waveform shapes and movements. In an embodiment, the machine learning algorithm may include one or more of: a “random forest”, deep belief network trained using restricted Boltzmann machines, or support vector machine. The analysis may use any known regression analysis technique, such as, for example and without limitation, random forests, support vector machines, or a deep belief network trained using restricted Boltzmann machines.

**[0156]** The learning vector **1706** is generated at **1908** and may include one or more processing parameters. The learning vector **1706** including processing parameters are provided to the biosensor **100** or neural network processing device **1700**. The neural network processing device **1700** is configured with the processing parameters in the learning vector **1706**. The neural network processing device may then process input vectors derived using PPG signals to obtain output vectors including motion data.

**[0157]** In an embodiment, the input vector is derived from one or more PPG signals at one or more wavelengths, such as of 390 nm, 660 nm, 440 nm, 468 nm, 530 nm, 550 nm, 592 nm, 880 nm, 940 nm or in a range of  $\pm 20$  nm from these wavelengths. The PPG signals are measured over a time period, such as 2-3 cardiac cycles. The light in the UV range, such as 390 nm or in a range of  $\pm 20$  nm, reflected from certain body parts provides an improved PPG signal. For example, UV light reflected from a face provides an improved PPG signal, especially in non-contact PPG imaging systems.

**[0158]** In an embodiment, the training set is continually updated, e.g. from user input. The learning vector **1706** may be periodically updated (such as hourly, daily, etc.). The updated learning vector **1706** may then be obtained and configured on the neural network processing device **1700** periodically as well (such as hourly, daily, etc.). In addition, a user may update a learning vector **1706** based on a tutorial or program that instructs a user to move certain body parts while PPG signals are measured. These measurements may be taken over a few minutes, hours, days or weeks to calibrate a neural network processing device **1700** to generate a user’s training set. This training set may be used to update the learning vector **1706** for the user’s neural network processing device **1700**.

**[0159]** FIG. **20** illustrates a schematic block diagram of an embodiment of a neural network processing device **1700** in more detail. The neural network (NN) processing device **1700** includes a NN processing circuit **2002** and NN memory device **2004**. The NN memory device **2004** stores a learning vector **1706** and updates thereto. An input vector generation module **2008** is configured to generate the input vector **1702** from PPG signals and accelerometer data. The PPG signals may be obtained by a PPG circuit **110** or a non-contact camera. A signal processing circuit **2012** may be incorporated into the NN processing device **1700** to process the PPG signals to generate the PPG input data.

**[0160]** The input vector generation module **2008** generates an input vector **1702** including the PPG input data and/or the motion sensor data. The NN processing circuit **2002** is configured to implement a machine learning algorithm configured with the learning vector **1706**. The NN processing circuit **2002** may also compare the output vector **1704** to thresholds in the output vector to calibrate or verify the results. The NN transceiver **2010** may transmit the output vector **1704** and input vector **1702** to another device, such as smart phone, smart watch, laptop, or other user device.

**[0161]** The NN processing device **1700** may be pre-configured with learning parameters, e.g. from a learning vector generated using a training set of a general population. The training set includes a similar data in an input vector and known results in an output vector. The learning vector may then be updated based on a user’s PPG signals and indicated movements.

**[0162]** In another embodiment, the NN processing device **1700** may also determine a heart rate, e.g. from a high frequency component of the PPG signal or systolic and diastolic points of the PPG signal. In addition, the NN processing device **1700** may determine a low frequency component of a PPG signal to obtain a respiration rate or level of vasodilation. In another embodiment, characteristic features of the PPG waveform, such as amplitudes and phases of cardiac components, may be extracted and used to train the neural network to determine a blood pressure. See,

e.g., Xing X, Sun M., “Optical blood pressure estimation with photoplethysmography and FFT-based neural networks.” *Biomedical Optics Express*. 2016; 7(8):3007-3020, which is hereby incorporated by reference herein.

**[0163]** FIG. 21 illustrates a logical flow diagram of an embodiment of a method 2100 for generating PPG signal patterns. PPG signals are obtained at one or more wavelengths during known movement of a body part at 2102. The PPG signals are collected from test subjects in the general population as test samples. Preferably, the PPG signals are detected at a same position during each test. A template for a PPG signal pattern is generated from the test samples at 2104. The PPG signal pattern is stored in a database or file with corresponding motion data, e.g. the known movement of the body part at 2106. The PPG signal pattern may also be associated with a command or instruction for controlling a device. The PPG signal pattern and associated data may be stored in a file or database and provided to the biosensor for initial use at 2108. For example, the PPG signal patterns may be used as a starting pattern to identify movement of a body part from PPG signals of a user.

**[0164]** FIG. 22 illustrates a logical flow diagram of an embodiment of a method 2200 for a training mode to determine customized PPG signal patterns. A biosensor 100 may initiate a training mode for customization of the PPG signal patterns at 2202. The training mode may be initiated upon a first use or upon request of a user. During the training mode, a GUI of the biosensor or user device in communication with the biosensor requests movement of a particular body part at 2204. The request may also include a type of movement, such as move right finger up and down or rotate hand to the right. The biosensor 100 obtains PPG signals during the requested movement of the body part at 2206. The PPG signal pattern of the user is stored in the PPG signal pattern file and associated with the request movement. The PPG signal pattern of the user may be used to modify or replace the generic PPG signal pattern at 2208. The training mode continues for other types of movements of the same body part and/or for movements of other body parts at 2210.

**[0165]** In another embodiment, the training of the biosensor 100 may be performed using a 3-D motion capture or video analysis system. The 3-D motion capture or video analysis system obtains motion data while the biosensor 100 monitors PPG signals. The motion artifacts in the PPG signals at one or more wavelengths are mapped to the motion data to generate predetermined PPG signal patterns. The motion data may be input with the PPG signals into a neural network processing device to generate a learning vector as well.

**[0166]** FIG. 23 illustrates a logical flow diagram of an embodiment of a method 2300 for detecting neural activity using PPG signals. Electrical activity is produced to stimulate and activate muscles. However, in some instances, these muscles are not operable or non-existent as in an amputated limb. The electrical stimulation of the muscle may occur with little to no movement. In another embodiment, a person may train the biosensor 100 to detect neural stimulation or activity with little to no movement of a body part. Even when little to no movement occurs, the electrical activity generates a change in potential of muscles and/or vasodilation of surrounding vessels and thus changes the optical properties of the underlying tissue. PPG signals may then detect this change in the optical properties.

**[0167]** PPG signals are obtained at one or more wavelengths at 2302. Though little or no movement occurs, the PPG signals reflect neural activity in underlying tissue. The neural activity is identified in the PPG and data associated with the neural activity is obtained at 2306. For example, the neural activity may be associated with an input command or type of movement of a body part. A device may be controlled based on the data associated with the neural activity at 2308. In one embodiment, the biosensor 100 is used to control a prosthetic limb using detection of neural activity. In another embodiment, the biosensor 100 is used to control a cursor or keyboard without movement based on detected neural activity.

**[0168]** FIG. 24 illustrates a logical flow diagram of an embodiment of a method 2400 for detecting neural activity or movement of a body part using one or more types of sensors. PPG signals are obtained at one or more wavelengths at 2402. Motion sensor data from the motion sensor, such as an accelerometer or gyroscope, is obtained at 2404. The motion sensors may provide motion data relating to movement of the biosensor in three-dimensional (3D) space in relation to a portion of the user or to a control plane.

**[0169]** Data from other types of sensors for detecting motion may also be obtained at 2406. For example, an electromyography (EMG) sensor may detect neural activity for activation of muscles at one or more locations on the hand or at other parts of the body. A 3-D motion capture or video analysis system may be used to obtain motion data as well. Data obtained from an electrocardiogram sensor (ECG or EKG) or an electroencephalogram (EEG) sensor may also be used. The data from one or more of the types of sensors may be used to determine motion data at 2408.

**[0170]** FIG. 25 illustrates a logical flow diagram of an embodiment of a method 2500 for positioning of a biosensor 100. The biosensor 100 may have different form factors, such as a watch, bracelet, patch, earbud, glasses, finger attachment, etc. In each form factor, the biosensor 100 is preferably positioned to emit light at the skin tissue of a user and detect light reflected from the skin tissue or light transmitted through the skin tissue. When the biosensor 100 is not properly positioned adjacent to skin tissue, the biosensor 100 may not be able to adequately detect the light from the skin. The PPG signals need to be detected with a sufficient quality for processing of the motion artifacts. In an embodiment, the biosensor 100 generates a request to a user to adjust a position of the form factor when the PPG signals have a low quality below a predetermined threshold.

**[0171]** The biosensor 100 initiates motion detection mode at 2502 and obtains PPG signals at 2504. The quality or noise in the PPG signals may be analyzed at one or more wavelengths at 2506. For example, the heart rate signal may be derived using the PPG signals, and the quality of the heart rate signal determined as a test of the quality of the PPG signal. In an embodiment, the quality of the PPG signal may be analyzed at multiple wavelengths in one or more spectrums, in IR, UV or visible spectrums. The quality of the PPG signals may differ depending on the wavelength and underlying tissue characteristics. At a same input power, light at higher wavelengths (IR light) penetrates vascular tissue deeper than light at lower wavelengths (UV light). The optical properties of the tissue are affected by many factors, including but not limited to, skin-tone, tissue hydration, and tissue chemistry. In a sensor configuration where the light from the light source is backscattered to a sensor on the same

surface, the optical signal at the sensor includes a sum of all light backscattered that makes it to the focal surface after interacting with the tissue. With the optical power being the same across all wavelengths, some of the light backscattered from the IR light penetrates deeper into the tissue than the UV light does. This means that the different wavelengths of light probe different depths of tissue. Thus, depending on the type of vascular tissue and depth of the vessels, the IR light, visible light or UV light may result in a higher quality PPG signal.

[0172] The biosensor 100 may determine the one or more spectrums of light resulting in higher quality PPG signals, and the one or more wavelengths in the spectrums of light with higher quality PPG signals at 2508. The biosensor 100 may then utilize the determined one or more wavelengths in the spectrums with higher quality to obtain the PPG signals.

[0173] If the wavelengths fail to meet a predetermined threshold of quality (such as a signal to noise ratio) or the biosensor 100 may not reliably detect a heart rate in the PPG signals, the biosensor 100 may determine that the position of the biosensor 100 needs to be adjusted at 2510. For example, when the PPG signal at one or more wavelengths falls below a predetermined quality, the biosensor 100 may generate a request or indication to reposition the biosensor 100 on the user at 2512. The indication or request may simply be an LED that is red or green depending on the quality of the PPG signal. A sound may alert the user to reposition the biosensor. The biosensor 100 continues to monitor the PPG signal and indicate to reposition the biosensor 100 until the quality is sufficient to obtain motion data. The biosensor 100 then continues to obtain PPG signals and detect motion data at 2514.

[0174] FIG. 26-29 illustrate schematic block diagram of various form factors of the biosensor 100. The biosensor 100 may be integrated in a watch, patch, button, band, earpiece, earphones, ankle bracelet or other devices adjacent to skin of a patient.

[0175] FIG. 26 illustrates a schematic block diagram of an embodiment of the biosensor 100 integrated in a finger attachment 2600. The biosensor 100 is positioned such that the emitting light sources and photodetectors are adjacent to a fingertip positioned in the finger attachment. The finger attachment 2600 may also include one or more types of displays and/or one or more other types of user interfaces.

[0176] FIG. 27A illustrates a perspective view of a first side of another embodiment of the biosensor 100 integrated in a patch 2700. The first side 2720 of the patch 2700 is configured to face upwards away from skin tissue of a patient. A user interface circuit 2710 is configured to provide a user with control to select one or more modes of operation. In one embodiment, the user interface circuit 2710 may include a push button or dial or touchscreen. A mode indicator 2704 is configured to indicate the mode of operation of the patch 2700. In an embodiment, the mode indicator 2704 may include one or more LEDs that illuminate to illustrate one or more modes of operation.

[0177] The patch 2700 may also include a position indicator 2716 that indicates that the biosensor 100 needs to be repositioned for improved detection of PPG signals. The patch 2700 may also include a health alert indicator 2706 to provide a warning or health alert. The health alert indicator 2706 in this embodiment includes a first LED that may illuminate to provide a status or indication of a health condition. For example, the LED may illuminate if a high

heart rate, temperature or respiration rate above safe thresholds are detected. The patch 2700 may in addition to or alternatively include an audible indicator 2708 configured to provide audible or verbal indications or alerts. The visible indicator may also include a digital display.

[0178] The patch 2700 may also include a heart rate (bpm) indicator 2702. The heart rate indicator 2702 may include an LED that blinks or changes color upon detection of a heartbeat. A person may thus count a number of heartbeats using the flashing LED. Though LEDs are described herein to provide various types of information and alerts, the patch 2700 may implement other types of user interfaces, such as a display or touchscreen or a verbal interface, to provide such alerts and information. The patch 2700 may also include a transceiver 2712, wired or wireless, to communicate with another device. For example, the transceiver 2712 may include a USB port for a wired communication or an RFID or Bluetooth wireless transceiver. The transceiver 2712 may communicate configuration information to the patch 2700 or communicate motion data or commands from the patch 2700 to a user device or other type of device.

[0179] FIG. 27B illustrates a perspective view of a second side of an embodiment of the biosensor 100 integrated in the patch 2700. The second side of the patch 2700 is configured to face towards skin tissue of a user. The PPG 110 includes at least a first photodiode 2724 and may also include a second photodiode 2726. The photodiodes 2724, 2726 are positioned on opposite sides of a plurality of LEDs 2728. The LEDs 2728 are configured to emit light at a plurality of wavelengths. For example, a first wavelength is in a UV range of 380-410 nm and is preferably 390 nm or 395 nm. A second wavelength is in an IR range, such as approximately 660 nm, and a third wavelength is an IR range, such as approximately 940 nm. Additional or alternative LEDs may be included that have different wavelengths. The patch 2700 may also include a temperature sensor 2730 configured to detect a skin temperature of the patient. A gasket 2732 is implemented to hold the PPG circuit 110 in position.

[0180] FIG. 28A illustrates a perspective view of an embodiment of the biosensor 100 configured in an earpiece 2800. The earpiece 2800 is configured to fit within an ear canal of a user. FIG. 28B illustrates another perspective view of the biosensor 100 integrated in the earpiece 2800. The earpiece 2800 may be used to detect movement of facial muscles using PPG signals. The motion artifacts in the detected PPG signals are correlated with predetermined PPG signal patterns associated with facial movements or facial expressions. The earpiece 2800 may thus detect facial expressions or movements using PPG signals.

[0181] FIG. 29A and FIG. 29B illustrate a perspective view of another embodiment of a biosensor 100 integrated in a wristband 2900. FIG. 29A illustrates a bottom portion 2902 of the wristband 2900 with an integrated biosensor 100. The light sources and photodetector of the biosensor 100 is positioned adjacent to skin tissue of the user. In this embodiment, the biosensor 100 is implemented with an adjustable band 2908. The adjustable band 2900 may be configured to fit around a wrist, arm, leg, ankle, etc. The bottom portion 2902 of the biosensor 100 includes at least one opening for the PPG circuit 110 to emit light directed to the skin tissue and detect light reflected from the skin tissue of a user. A USB or other port 2906 may be implemented to transmit data to and from the biosensor 100. The biosensor 100 may also include a wireless transceiver.

[0182] FIG. 29B illustrates a perspective view of a top portion 2904 of the wristband 2900 including the biosensor 100. Though not shown, the top portion of the biosensor 100 may include a display or other user interface.

[0183] FIG. 29C illustrates the wristband 2900 positioned on a wrist of a user. The bottom portion 2902 is preferably positioned on a top part of the wrist of the user since the upper portion of the wrist includes a greater density of vessels near the surface of the underlying tissue. In an embodiment, the photodetector is more centrally located on the bottom portion 2902 with the light sources or LEDs arranged in positions around the photodiode. The spatially distributed LEDs on the bottom portion provide better detection of a range of motion of the hand. The LEDs do not need to be placed in specific positions, such as over tendons or muscles or nerves. A plurality of LEDs dispersed across the bottom portion 2902 of the biosensor 100 may detect movement of the hand and all the fingers. The PPG signals detected by a plurality of the LEDs may each be considered to determine a motion vector of a body part.

[0184] In an embodiment, an existing device, such as an activity monitoring device, a smart phone with camera, or a smart watch, may be implemented as the biosensor 100. These existing devices may already include an LED and photodetector and may be configured to obtain PPG signals from light reflected from the skin. The processing of the PPG signals may be performed by the existing devices (e.g., with new downloaded software upgrades) or the processing may be performed by a smart phone, laptop, central server or other secondary device in communication with the existing devices. The secondary devices may then communicate the results back to the existing device.

[0185] FIG. 30 illustrates a schematic diagram of a graph 3000 of spectral responses obtained using an embodiment of the biosensor 100 while the hand is relaxed. The biosensor 100 is positioned on the wrist of the right hand of the user as shown in FIG. 29C. The hand is flat, and fingers relaxed.

[0186] Again, in this example, the biosensor 100 obtained a PPG signal around a wavelength at 940 nm, a wavelength at 880 nm and a wavelength at 660 nm as shown in the PPG Signals for Wavelength Group 3010a. The biosensor 100 also obtained the spectral response for a wavelength at 590 nm, a wavelength at 530 nm and a wavelength at 470 nm as shown in the PPG Signals for Wavelength Group 3010b. The biosensor 100 further obtained the spectral response for a wavelength at 405 nm, a wavelength at 400 nm and a wavelength at 395 nm as shown in the PPG Signals for Wavelength Group 3010c.

[0187] The PPG signals at the plurality of wavelengths include a response to the pressure pulse wave through the vessels from the cardiac cycle. The cardiac cycle is more pronounced in the PPG signals for Wavelength Group 3010c. These wavelengths are in the UV range. Depending on placement of the biosensor 100, the wavelengths in one or more spectrums may be more sensitive to the heart rate or to motion artifacts. There is little to no indication of movement of the hand or fingers in the PPG signals.

[0188] FIG. 31 illustrates a schematic diagram of a graph 3104 of spectral responses obtained using an embodiment of the biosensor 100 during movement of the hand into a fist. The biosensor 100 is still positioned on the wrist of the right hand of the user and has not been repositioned from FIG. 30. During this measurement period, the user moves the right hand from a relatively flat position into a fist.

[0189] Again, in this example, the biosensor 100 obtained a PPG signal around a wavelength at 940 nm, a wavelength at 880 nm and a wavelength at 660 nm as shown in the PPG Signals for Wavelength Group 3100a. The biosensor 100 also obtained the spectral response for a wavelength at 590 nm, a wavelength at 530 nm and a wavelength at 470 nm as shown in the PPG Signals for Wavelength Group 3100b. The biosensor 100 further obtained the spectral response for a wavelength at 405 nm, a wavelength at 400 nm and a wavelength at 395 nm as shown in the PPG Signals for Wavelength Group 3100c.

[0190] The PPG signals at the plurality of wavelengths include a response to the pressure pulse wave through the vessels from the cardiac cycle. In addition, at approximately the time of 365.5 seconds, there is an indication of movement of the hand in the PPG signals at 3102a, 3102b and 3102c. The PPG signals at each wavelength have a somewhat different or unique pattern in response to the movement of the hand. These patterns 3102a-c in the PPG signal are not present in the PPG signals with little to no movement shown in FIG. 30. The unique PPG signal pattern at each wavelength may be used to identify the movement of the hand to a fist in later obtained waveforms.

[0191] FIG. 32 illustrates a schematic diagram of a graph 3204 of spectral responses obtained using an embodiment of the biosensor 100 during a downward thumb movement. The biosensor 100 is still positioned on the wrist of the right hand of the user and has not been repositioned from FIG. 30. During this measurement period, the user holds the right hand relatively relaxed and level while moving the thumb downward.

[0192] Again, in this example, the biosensor 100 obtained a PPG signal around a wavelength at 940 nm, a wavelength at 880 nm and a wavelength at 660 nm as shown in the PPG Signals for Wavelength Group 3200a. The biosensor 100 also obtained the spectral response for a wavelength at 590 nm, a wavelength at 530 nm and a wavelength at 470 nm as shown in the PPG Signals for Wavelength Group 3200b. The biosensor 100 further obtained the spectral response for a wavelength at 405 nm, a wavelength at 400 nm and a wavelength at 395 nm as shown in the PPG Signals for Wavelength Group 3200c.

[0193] The PPG signals at the plurality of wavelengths include a response to the pressure pulse wave through the vessels from the cardiac cycle. In addition, at approximately the time of 447.5 seconds, there is an indication of movement of the hand in the PPG signals at 3202a, 3202b and 3202c. The PPG signals at each wavelength have a somewhat different or unique pattern in response to the movement of the thumb. These patterns 3202a-c in the PPG signal are not present in the PPG signals with little to no movement shown in FIG. 30. The unique PPG signal pattern at each wavelength may be used to identify the downward movement of the thumb.

[0194] FIG. 33 illustrates a schematic diagram of a graph 3300 of data generated from the spectral responses obtained using an embodiment of the biosensor 100 during the downward thumb movement shown in FIG. 32. In graph 3302, the average DC Level is shown for each of the wavelengths. The average DC level during motion artifacts are indicative of a force applied to a movement. A maximum amplitude of the motion artifact may also be used as an indication of force applied to a movement.

[0195] FIG. 34 illustrates a schematic diagram of a graph 3400 of additional data generated from the spectral responses obtained using an embodiment of the biosensor 100 during the downward thumb movement shown in FIG. 32. In graph 3402, the motion artifact 3202a in the IR range of 940 nm is shown while the motion artifact 3202c in the UV range of 395 nm is shown. The cardiac cycle is more prevalent in the UV range, and the motion artifact 3202c is reflected in the PPG signal over the cardiac cycle. The depth of penetration of the light into tissue depends on the spectrum. Thus, the wavelengths in one or more spectrums may be more sensitive to the cardiac cycle or to the movement depending on the position of the biosensor 100. The motion artifacts at different wavelengths may thus be different and have unique PPG signal patterns for a same movement. The biosensor 100 may thus identify a motion artifact in multiple wavelengths occurring at a similar time. The motion artifacts at each wavelength may be compared to predetermined PPG signal patterns for their respective wavelength to determine motion data.

[0196] Neural activity or stimulation generates a muscular reaction during a movement of a body part. This neural activity is reflected in the PPG signal, especially at initiation of the motion artifact. For example, the motion artifact 3202a includes an initial change in the PPG signal 3404 in response to neural activity. The motion artifact 3202c also includes an initial change in the PPG signal 3408 in response to neural activity.

[0197] FIG. 35 illustrates a schematic diagram of a graph 3500 of spectral responses obtained using an embodiment of the biosensor 100 during an upward thumb movement. The biosensor 100 is still positioned on the wrist of the right hand of the user and has not been repositioned from FIG. 30. During this measurement period, the right hand is held relatively flat while the thumb is moved upward.

[0198] Again, in this example, the biosensor 100 obtained a PPG signal around a wavelength at 940 nm, a wavelength at 880 nm and a wavelength at 660 nm as shown in the PPG Signals for Wavelength Group 3504a. The biosensor 100 also obtained the spectral response for a wavelength at 590 nm, a wavelength at 530 nm and a wavelength at 470 nm as shown in the PPG Signals for Wavelength Group 3504b. The biosensor 100 further obtained the spectral response for a wavelength at 405 nm, a wavelength at 400 nm and a wavelength at 395 nm as shown in the PPG Signals for Wavelength Group 3504c.

[0199] The PPG signals at the plurality of wavelengths include a response to the pressure pulse wave through the vessels from the cardiac cycle. In addition, at approximately the time of 735.5 seconds, there is an indication of movement of the hand in the PPG signals at 3502a, 3502b and 3502c. The PPG signals at each wavelength have a somewhat different or unique pattern in response to the movement of the thumb. These patterns 3502a-c in the PPG signal are not present in the PPG signals with little to no movement shown in FIG. 30. The unique PPG signal pattern at each wavelength may be used to identify the upward movement of the thumb.

[0200] FIG. 36 illustrates a schematic diagram of a graph 3600 of additional data generated from the spectral responses obtained using an embodiment of the biosensor 100 during the upward thumb movement shown in FIG. 35. The motion artifact 3502a in the IR range of 940 nm is shown in the top graph 3602 while the motion artifact 3502c

in the UV range of 395 nm is shown in the bottom graph 3604. The cardiac cycle is more prevalent in the UV range, however the motion artifact 3502c is still reflected in the PPG signal over the cardiac cycle. The depth of penetration of the light into tissue depends on the spectrum, such as UV or IR light. Thus, the wavelengths in different spectrums may have different sensitivities to the cardiac cycle or to the movement depending on the position of the biosensor 100. The motion artifacts generated from a same movement may thus be different at different wavelengths and have unique PPG signal patterns. The biosensor 100 may identify motion artifacts in multiple wavelengths occurring at a similar time. The motion artifacts at each wavelength may be compared to predetermined PPG signal patterns for their respective wavelength to determine motion data.

[0201] FIG. 37 illustrates a schematic diagram of a graph 3700 of spectral responses obtained using an embodiment of the biosensor 100 during an upward movement of the index finger. The biosensor 100 is still positioned on the wrist of the right hand of the user and has not been repositioned from FIG. 30. During this measurement period, the right hand is held flat with an upward movement of the index finger.

[0202] Again, in this example, the biosensor 100 obtained a PPG signal around a wavelength at 940 nm, a wavelength at 880 nm and a wavelength at 660 nm as shown in the PPG Signals for Wavelength Group 3704a. The biosensor 100 also obtained the spectral response for a wavelength at 590 nm, a wavelength at 530 nm and a wavelength at 470 nm as shown in the PPG Signals for Wavelength Group 3704b. The biosensor 100 further obtained the spectral response for a wavelength at 405 nm, a wavelength at 400 nm and a wavelength at 395 nm as shown in the PPG Signals for Wavelength Group 3704c.

[0203] The PPG signals at the plurality of wavelengths include a response to the pressure pulse wave through the vessels from the cardiac cycle. In addition, at approximately the time of 952.5 seconds, there is an indication of movement of the hand in the PPG signals at 3702a, 3702b and 3702c. The PPG signals at each wavelength have a somewhat different or unique pattern in response to the movement of the index finger. These patterns 3702a-c in the PPG signal are not present in the PPG signals with little to no movement shown in FIG. 30. The unique PPG signal pattern at each wavelength may be used to identify the upward movement of the index finger.

[0204] FIG. 38 illustrates a schematic diagram of a graph 3800 of spectral responses obtained using an embodiment of the biosensor 100 while the left hand is relaxed. The biosensor 100 is positioned on the wrist of the left hand of the user. The hand is relatively level and fingers relaxed.

[0205] Again, in this example, the biosensor 100 obtained a PPG signal around a wavelength at 940 nm, a wavelength at 880 nm and a wavelength at 660 nm as shown in the PPG Signals for Wavelength Group 3810a. The biosensor 100 also obtained the spectral response for a wavelength at 590 nm, a wavelength at 530 nm and a wavelength at 470 nm as shown in the PPG Signals for Wavelength Group 3810b. The biosensor 100 further obtained the spectral response for a wavelength at 405 nm, a wavelength at 400 nm and a wavelength at 395 nm as shown in the PPG Signals for Wavelength Group 3810c.

[0206] The PPG signals at the plurality of wavelengths include a response to the pressure pulse wave through the vessels in response to the cardiac cycle. The cardiac cycle is

more pronounced in the PPG signals for Wavelength Group **3810C**. These wavelengths are in the UV range. Depending on placement of the biosensor **100**, the wavelengths in one or more spectrums may be more sensitive to the heart rate or to motion artifacts. There is little to no indication of movement of the hand or fingers in the PPG signals.

[0207] FIG. **39** illustrates a schematic diagram of a graph **3900** of spectral responses obtained using an embodiment of the biosensor **100** during a mental intention to move a left index finger but with little to no actual movement. The biosensor **100** is still positioned on the wrist of the left hand of the user and has not been repositioned from FIG. **38**. The PPG signals at the plurality of wavelengths include a response to the pressure pulse wave through the vessels from the cardiac cycle.

[0208] Again, in this example, the biosensor **100** obtained a PPG signal around a wavelength at 940 nm, a wavelength at 880 nm and a wavelength at 660 nm as shown in the PPG Signals for Wavelength Group **3902a**. The biosensor **100** also obtained the spectral response for a wavelength at 590 nm, a wavelength at 530 nm and a wavelength at 470 nm as shown in the PPG Signals for Wavelength Group **3902b**. The biosensor **100** further obtained the spectral response for a wavelength at 405 nm, a wavelength at 400 nm and a wavelength at 395 nm as shown in the PPG Signals for Wavelength Group **3902c**.

[0209] During this measurement period, the left hand is still at rest or held relatively level with little to no movement. The user concentrates on mentally activating or initiating an upward movement of the index finger on the left hand but with little to no actual movement. The user may mentally envision moving the index finger or activating muscles in the index finger but with little to no movement. As a result, some neural activity, increased blood flow and vasodilation may occur. The PPG signals include a small fluctuation due to the neural activity and/or vasodilation as seen at **3904a**, **3904b** and **3904c**. The small fluctuation occurs between approximately 105.5 to 106 seconds. The PPG signals at each wavelength have a somewhat different or unique pattern in response to the intended or mental movement of the index finger. These patterns **3904a-c** in the PPG signal are not present in the PPG signals with little to no movement shown in FIG. **38**. The unique PPG signal pattern at each wavelength may be used to identify the mental intention to move the left index finger with little to no movement. A user may train the biosensor **100** to detect these mental intentions of movement and so control a device with little to no actual movement.

[0210] FIG. **40** illustrates a schematic diagram of a graph **4000** of spectral responses obtained using an embodiment of the biosensor **100** during a mental intention to move a pinky finger upward but with little to no actual movement. The biosensor **100** is still positioned on the wrist of the left hand of the user and has not been repositioned from FIG. **38**. The PPG signals at the plurality of wavelengths include a response to the pressure pulse wave through the vessels from the cardiac cycle.

[0211] Again, in this example, the biosensor **100** obtained a PPG signal around a wavelength at 940 nm, a wavelength at 880 nm and a wavelength at 660 nm as shown in the PPG Signals for Wavelength Group **4002a**. The biosensor **100** also obtained the spectral response for a wavelength at 590 nm, a wavelength at 530 nm and a wavelength at 470 nm as shown in the PPG Signals for Wavelength Group **4002b**. The

biosensor **100** further obtained the spectral response for a wavelength at 405 nm, a wavelength at 400 nm and a wavelength at 395 nm as shown in the PPG Signals for Wavelength Group **4002c**.

[0212] During this measurement period, the left hand is still at rest or held relatively level with little to no movement. The user concentrates on mentally activating or initiating an upward movement of the pinky finger on the left hand but with little to no actual movement. The user may mentally envision moving the pinky finger or activating muscles in the pinky finger but with little to no movement. As a result, some neural activity, increased blood flow and vasodilation may occur. The PPG signals include a small fluctuation due to the neural activity and/or vasodilation as seen at the PPG signal patterns **4004a**, **4004b** and **4004c**. The small fluctuation occurs around 239.5 seconds. The PPG signals at each wavelength have a somewhat different or unique pattern in response to the intended or mental movement of the pinky finger. These patterns **4004a-c** in the PPG signal are not present in the PPG signals with little to no movement shown in FIG. **38**. The unique PPG signal pattern at each wavelength may be used to identify the mental intention to move the pinky finger (but with little to no movement). A user may train the biosensor **100** to detect these mental intentions of movement and so control a device with little to no actual movement.

[0213] FIG. **41** illustrates a schematic diagram of a graph **4100** of spectral responses obtained using an embodiment of the biosensor **100** during a mental intention to move a left thumb upward but with little to no actual movement. The biosensor **100** is still positioned on the wrist of the left hand of the user and has not been repositioned from FIG. **38**. The PPG signals at the plurality of wavelengths include a response to the pressure pulse wave through the vessels from the cardiac cycle.

[0214] Again, in this example, the biosensor **100** obtained a PPG signal around a wavelength at 940 nm, a wavelength at 880 nm and a wavelength at 660 nm as shown in the PPG Signals for Wavelength Group **4102a**. The biosensor **100** also obtained the spectral response for a wavelength at 590 nm, a wavelength at 530 nm and a wavelength at 470 nm as shown in the PPG Signals for Wavelength Group **4102b**. The biosensor **100** further obtained the spectral response for a wavelength at 405 nm, a wavelength at 400 nm and a wavelength at 395 nm as shown in the PPG Signals for Wavelength Group **4102c**.

[0215] During this measurement period, the left hand is still at rest or held relatively level with little to no movement. The user concentrates on mentally activating or initiating an upward movement of the thumb on the left hand but with little to no actual movement. The user may mentally envision moving the thumb or activating muscles in the thumb but with little to no movement. As a result, some neural activity, increased blood flow and vasodilation may occur. The PPG signals include a small fluctuation due to the neural activity and/or vasodilation as seen at the PPG signal patterns **4104a**, **4104b** and **4104c**. The small fluctuation occurs around 328.5 seconds. The PPG signals at each wavelength have a somewhat different or unique pattern in response to the intended or mental movement of the thumb. These patterns **4104a-c** in the PPG signal are not present in the PPG signals with little to no movement shown in FIG. **38**. The unique PPG signal pattern at each wavelength may be used to identify the mental intention to move the pinky

finger (but with little to no movement). A user may train the biosensor 100 to detect these mental intentions of movement and so control a device with little to no actual movement.

[0216] The biosensor 100 may thus obtain PPG signals at a plurality of wavelengths to identify a motion artifact or fluctuation due to a mental or intended movement but with little to no actual movement. The biosensor 100 may then correlate the motion artifact in the PPG signal to a predetermined PPG signal pattern for intended movements. These signal patterns associated with intended movements will be different from the PPG signal patterns associated with actual movements.

[0217] The PPG signal patterns for intended movements are associated with motion data and stored in a database. The motion data includes the intended movement, such as the body part and direction of movement (up, down, left, right, retraction or extension or tensing of muscles) or type of movement (fist, rotation, etc.). The motion data may then be used to control operation of a device.

[0218] To obtain the PPG signal patterns for intended movement, the biosensor 100 may operate in a training mode. The training mode is initiated, and a request (verbal or nonverbal) is generated to a user to mentally envision movement of a body part and type or direction of movement. The user is instructed to not actually move the body part but only concentrate on mentally initiating or intending to perform the movement. The PPG signals are then obtained while the user concentrates on the intended movement. A motion artifact in the PPG signal is identified and associated with motion data. The motion data includes an identification of the body part and the intended movement of the body part. A user may thus train the biosensor 100 to detect these mental intentions of movement using the PPG signals and so control a device with little to no actual movement.

[0219] FIG. 42 illustrates a schematic block diagram of an embodiment of the biosensor 100 configured to control a device 4204 using PPG signals. The biosensor 100 may be implemented in a smart PPG enabled watch 4200 or activity monitoring type device such as a Fitbit. The biosensor 100 may include a PPG signal pattern database 4202 or communicate with a central server that provides access to or updates to the PPG signal pattern database 4202. The PPG signal pattern database 4202 includes a plurality of PPG signal patterns at each of a plurality of wavelengths. The plurality of PPG signal patterns are associated with motion data.

[0220] The biosensor 100 detects movement using PPG signals. The biosensor 100 obtains motion data and communicates the motion data or control signals to a device 4204. The device 4204 may be a user device, medical device, or any other type of device requiring a man-machine interface. The motion data may be used to control a user interface type device, such as virtual keyboard 4206 for texting or typing. Predictive typing, word suggestion or spell checking may be included with the virtual keyboard 4206. The motion data may also be used to control a virtual mouse 4208, touchpad, touchscreen, joystick, game controller or cursor on a GUI. A wireless USB device may be implemented as the user interface type device, such as the virtual keyboard, touchpad, touchscreen, joystick, etc. The USB device communicates with the biosensor 100 and generates commands to the device 4204 in response to the motion data.

[0221] The motion data may also be used to control applications 4210, such as gaming applications, word pro-

cessing, web browsers, email, etc. For example, moving an index finger left or right against a surface or in the air may move a cursor left or right on a screen. A double tap of an index finger may select a control command or menu item.

[0222] FIG. 43 illustrates a schematic block diagram of another embodiment of the biosensor 100 configured to control a device 4300 using PPG signals. In this embodiment, the device may include a television. In an embodiment, the motion data may be associated with predetermined commands. For example, motion data including a fist may be associated with the command "turn off TV". A movement of a thumb down may be associated with the command "Change channel on the TV." The commands associated with the motion may be preprogrammed or programmed by a user. The gesture remote controller 4302 controls the television 4300 based on the motion data and the associated command. The device 4300 may also include a vehicle and motion data may be used to control navigation, climate, entertainment systems, or other operations of the vehicle.

[0223] In an embodiment, the biosensor 100 may obtain a stress level using the PPG signals. The tension and duration of tension in muscles may be measured over an extended time period using the PPG signals. The biosensor 100 may then obtain a stress level using the information.

[0224] In one or more aspects herein, a processing module or circuit includes at least one processing device, such as a microprocessor, micro-controller, digital signal processor, microcomputer, central processing unit, field programmable gate array, programmable logic device, state machine, logic circuitry, analog circuitry, digital circuitry, and/or any device that manipulates signals (analog and/or digital) based on hard coding of the circuitry and/or operational instructions. A memory is a non-transitory memory device and may be an internal memory or an external memory, and the memory may be a single memory device or a plurality of memory devices. The memory may be a read-only memory, random access memory, volatile memory, non-volatile memory, static memory, dynamic memory, flash memory, cache memory, and/or any non-transitory memory device that stores digital information.

[0225] As may be used herein, the term "operable to" or "configurable to" indicates that an element includes one or more of circuits, instructions, modules, data, input(s), output(s), etc., to perform one or more of the described or necessary corresponding functions and may further include inferred coupling to one or more other items to perform the described or necessary corresponding functions. As may also be used herein, the term(s) "coupled", "coupled to", "connected to" and/or "connecting" or "interconnecting" includes direct connection or link between nodes/devices and/or indirect connection between nodes/devices via an intervening item (e.g., an item includes, but is not limited to, a component, an element, a circuit, a module, a node, device, network element, etc.). As may further be used herein, inferred connections (i.e., where one element is connected to another element by inference) includes direct and indirect connection between two items in the same manner as "connected to".

[0226] As may be used herein, the terms "substantially" and "approximately" provides an industry-accepted tolerance for its corresponding term and/or relativity between items. Such an industry-accepted tolerance ranges from less than one percent to fifty percent and corresponds to, but is not limited to, frequencies, wavelengths, component values,

integrated circuit process variations, temperature variations, rise and fall times, and/or thermal noise. Such relativity between items ranges from a difference of a few percent to magnitude differences.

[0227] Note that the aspects of the present disclosure may be described herein as a process that is depicted as a schematic, a flowchart, a flow diagram, a structure diagram, or a block diagram. Although a flowchart may describe the operations as a sequential process, many of the operations can be performed in parallel or concurrently. In addition, the order of the operations may be re-arranged. A process is terminated when its operations are completed. A process may correspond to a method, a function, a procedure, a subroutine, a subprogram, etc. When a process corresponds to a function, its termination corresponds to a return of the function to the calling function or the main function.

[0228] The various features of the disclosure described herein can be implemented in different systems and devices without departing from the disclosure. It should be noted that the foregoing aspects of the disclosure are merely examples and are not to be construed as limiting the disclosure. The description of the aspects of the present disclosure is intended to be illustrative, and not to limit the scope of the claims. As such, the present teachings can be readily applied to other types of apparatuses and many alternatives, modifications, and variations will be apparent to those skilled in the art.

[0229] In the foregoing specification, certain representative aspects of the invention have been described with reference to specific examples. Various modifications and changes may be made, however, without departing from the scope of the present invention as set forth in the claims. The specification and figures are illustrative, rather than restrictive, and modifications are intended to be included within the scope of the present invention. Accordingly, the scope of the invention should be determined by the claims and their legal equivalents rather than by merely the examples described. For example, the components and/or elements recited in any apparatus claims may be assembled or otherwise operationally configured in a variety of permutations and are accordingly not limited to the specific configuration recited in the claims.

[0230] Furthermore, certain benefits, other advantages and solutions to problems have been described above with regard to particular embodiments; however, any benefit, advantage, solution to a problem, or any element that may cause any particular benefit, advantage, or solution to occur or to become more pronounced are not to be construed as critical, required, or essential features or components of any or all the claims.

[0231] As used herein, the terms “comprise,” “comprises,” “comprising,” “having,” “including,” “includes” or any variation thereof, are intended to reference a nonexclusive inclusion, such that a process, method, article, composition or apparatus that comprises a list of elements does not include only those elements recited, but may also include other elements not expressly listed or inherent to such process, method, article, composition, or apparatus. Other combinations and/or modifications of the above-described structures, arrangements, applications, proportions, elements, materials, or components used in the practice of the present invention, in addition to those not specifically recited, may be varied or otherwise particularly adapted to specific environments, manufacturing specifications, design

parameters, or other operating requirements without departing from the general principles of the same.

[0232] Moreover, reference to an element in the singular is not intended to mean “one and only one” unless specifically so stated, but rather “one or more.” Unless specifically stated otherwise, the term “some” refers to one or more. All structural and functional equivalents to the elements of the various aspects described throughout this disclosure that are known or later come to be known to those of ordinary skill in the art are expressly incorporated herein by reference and are intended to be encompassed by the claims. Moreover, nothing disclosed herein is intended to be dedicated to the public regardless of whether such disclosure is explicitly recited in the claims. No claim element is intended to be construed under the provisions of 35 U.S.C. § 112(f) as a “means-plus-function” type element, unless the element is expressly recited using the phrase “means for” or, in the case of a method claim, the element is recited using the phrase “step for.”

1. A biosensor, comprising:

a sensor configured for positioning over an area of tissue of the user and configured to obtain a photoplethysmography (PPG) signal, wherein the PPG signal includes a spectral response around a first wavelength of light detected from the area of the tissue of the user and wherein a distance between the sensor and the area of the tissue remains relatively constant;

a processing device configured to:

process the PPG signal at the first wavelength detected over the area of the tissue of the user to identify a first motion artifact at a first time interval; and

process the PPG signal at the first wavelength detected over the same area of the tissue of the user to identify a second motion artifact at a second time interval, wherein the first and second motion artifacts reflect changes in blood flow through vessels in the area of the tissue;

correlate the first motion artifact in the PPG signal to a first predetermined PPG signal pattern, wherein the first PPG signal pattern reflects changes in blood flow through vessels in the area of the tissue at the first time interval;

correlate the second motion artifact in the PPG signal to a second predetermined PPG signal pattern, wherein the second PPG signal pattern reflects changes in blood flow through vessels in the same area of the tissue at the second time interval;

obtain first motion data for a first moving body part using the first predetermined PPG signal pattern;

obtain second motion data for a second moving body part using the second predetermined PPG signal pattern, wherein the first moving body part and the second moving body part are different than a body part of the area of tissue of the user; and

control operation of a device in response to the first motion data or the second motion data.

2. The biosensor of claim 1, wherein the first predetermined PPG signal pattern is associated with the first motion data, wherein the first motion data includes an identification of the first moving body part; and

wherein the second predetermined PPG signal pattern is associated with the second motion data, wherein the second motion data includes an identification of the second moving body part.

3. The biosensor of claim 2, wherein the first motion data further includes a first motion vector for the first moving body part, and wherein the first motion vector indicates one or more of: a direction of movement of the first moving body part, a speed of the movement of the first moving body part or a force of the movement of the first moving body part; and

wherein the second motion data further includes a second motion vector for the second moving body part, and wherein the second motion vector indicates one or more of: a direction of movement of the second moving body part, a speed of the movement of the second moving body part or a force of the movement of the second moving body part.

4. The biosensor of claim 1, wherein the sensor is included in a band configured for positioning over the area of the tissue of a wrist or arm of the user and comprises:

a photodetector configured to detect light from the area of the tissue of the wrist or arm of the user;

a plurality of light sources spatially distributed around the photodetector, wherein the plurality of light sources emits light at a plurality of wavelengths in multiple spectrums; and

wherein the first moving body part includes a first finger of the user and the second moving body part includes a second finger of the user.

5. The biosensor of claim 1, wherein the processing device is configured to:

process a third PPG signal at a second wavelength to identify a third motion artifact in the third PPG signal; correlate the third motion artifact in the third PPG signal to a third predetermined PPG signal pattern; and obtain third motion data using the third predetermined PPG signal pattern.

6. The biosensor of claim 5, wherein the processing device is configured to compare the first motion data and the third motion data for verification of the first motion data.

7. The biosensor of claim 1, wherein the processing device is configured to:

obtain a direct current (DC) level or a maximum amplitude of the first motion artifact; and

determine a force of movement of the first moving body part using the DC level or the maximum amplitude of the first motion artifact.

8. The biosensor of claim 1, wherein the processing device is configured to:

obtain a heart rate using the first or second PPG signal; determine a quality factor of the heart rate signal; and process the first and second PPG signals when the quality factor exceeds a predetermined threshold.

9. The biosensor of claim 1, wherein the processing device is configured to:

process the PPG signal at the first wavelength to identify a level of vasodilation; and

determine the movement of the first moving body part using the level of vasodilation.

10. The biosensor of claim 1, wherein the biosensor further includes a motion sensor including one or more of: a gyroscope or an accelerometer; and

wherein the processing device is further configured to obtain motion data relating to movement of the biosensor in three-dimensional space relative to a control plane.

11. The device of claim 1, wherein the processing device is a neural network processing device and wherein an input

vector is generated using the PPG signal and wherein the neural network processing device generates an output vector including one or more of: identification of the movement of the first moving body part, a direction of the movement of the first moving body part, a speed of the movement of the first moving body part or a force of the movement of the first moving body part.

12. A wearable device for detecting movement, comprising:

a PPG sensor configured to obtain a PPG waveform from light detected from an area of skin adjacent to the wearable device of a user;

a processing circuit in communication with the PPG sensor and configured to:

determine a heart rate signal from the PPG waveform; determine a quality factor of the heart rate signal;

when the quality factor exceeds a predetermined threshold, identify a first motion artifact at a first time interval and a second motion artifact at a second time interval artifact in the PPG waveform detected from the same area of skin adjacent to the wearable device of the user;

compare the first and second motion artifacts to a plurality of predetermined PPG patterns in a database, wherein each of the plurality of predetermined PPG patterns is associated with one of a plurality of movements and one of a plurality of body parts;

correlate the first motion artifact in the PPG waveform to a first predetermined PPG pattern in the database and determine a movement and an identification of a first body part of the user using the first predetermined PPG pattern;

correlate the second motion artifact in the PPG waveform to a second predetermined PPG pattern in the database and determine a movement and an identification of a second body part of the user using the second predetermined PPG pattern; and

wherein the first body part and the second body part are different than a body part including the skin adjacent to the wearable device.

13. The wearable device of claim 12, wherein the processing circuit is further configured to: control an input device in response to the movement of the first or second body part, wherein the input device includes at least one of: a mouse, a keyboard, a touchscreen, a touchpad, a smart watch, a smart phone, a game controller, a vehicle, a joystick, or a graphical user interface (GUI) on a display.

14. The wearable device of claim 12, wherein the processing circuit is further configured to:

receive additional data from one or more of: electromyography (EMG) sensor, electrocardiogram (ECG) sensor or an electroencephalogram (EEG) sensor; and

determine the movement of the first or second body part using the additional data and the PPG waveform.

15. The wearable device of claim 12, wherein the processing circuit is further configured to:

initiate a training mode for customization of the first predetermined PPG pattern in a database;

request movement of the first body part of the user;

obtain a PPG signal of the user during the requested movement of the first body part;

identify a motion artifact in the PPG signal due to the requested movement of the body part; and

- update the first predetermined PPG pattern in the database using the motion artifact in the PPG signal.
- 16.** The wearable device of claim **12**, wherein the PPG sensor is further configured to:
- obtain the PPG waveform from light detected around a first wavelength of light in an ultraviolet (UV) range reflected from the area of skin adjacent to the wearable device of the user;
  - obtain a second PPG waveform from light detected around a second wavelength in an infrared (IR) range reflected from the same area of skin adjacent to the wearable device of the user;
  - compare a quality of the PPG waveform and the second PPG waveform; and
  - in response to the comparison, obtain additional PPG waveforms reflected from the same area of skin adjacent to the wearable device of the user for detection of movement from the UV range, the IR range or both the UV and IR range.
- 17.** The wearable device of claim **12**, wherein the processing circuit is further configured to:
- when the quality factor of the heart rate signal fails the predetermined threshold, generate a request to reposition the wearable device.
- 18.** The wearable device of claim **12**, wherein each of the plurality of predetermined PPG patterns in the database is further associated with a control command for a user device.
- 19.** A biosensor, comprising:
- a sensor configured to obtain a PPG signal, wherein the PPG signal includes a spectral response around a wavelength of light detected from tissue at a first body part of a user, wherein a distance between the sensor and the first body part remains relatively constant;
  - a processing device configured to:
    - identify a fluctuation in the PPG signal, wherein the fluctuation in the PPG signal reflects neural activity or vasodilation of vessels in the tissue of the user;
    - correlate the fluctuation in the PPG signal to a predetermined PPG signal pattern, wherein the predetermined PPG signal pattern is associated with an intended movement of a second body part due to a mental initiating of movement with little to no actual movement of the second body part;
    - determine the intended movement of the second body part using the predetermined PPG signal pattern; and
    - control operation of a device in response to the intended movement of the second body part.
- 20.** The biosensor of claim **19**, wherein the processing circuit is configured to obtain the predetermined PPG signal pattern by:
- initiating a training mode for the biosensor;
  - generating by the device a request to the user to mentally intend to move the second body part without actual movement of the second body part;
  - obtaining a training PPG signal around the first wavelength of light in response to the request;
  - identifying a fluctuation in the training PPG signal; and
  - update the predetermined PPG signal pattern using the fluctuation.
- 21.** The biosensor of claim **19**, wherein the processing device is configured to:
- process the PPG signal to identify a level of vasodilation; and
- determine the intended movement of the second body part using the predetermined PPG signal pattern and using the level of vasodilation.
- 22.** The biosensor of claim **19**, wherein the processing device is further configured to:
- process the PPG signal to identify neural activity due to the intended movement; and
  - determine the intended movement of the body part using the predetermined PPG signal pattern and the neural activity.
- 23.** A biosensor, comprising:
- a sensor configured to obtain a first PPG signal, wherein the first PPG signal includes a spectral response around a first wavelength of light detected from tissue of a first body part of a user;
  - a processing device configured to:
    - identify a fluctuation in the first PPG signal, wherein the fluctuation in the first PPG signal reflects neural activity or vasodilation of vessels in the tissue of the first body part of the user;
    - correlate the fluctuation in the PPG signal to a first predetermined PPG signal pattern, wherein the first predetermined PPG signal pattern is associated with an intended movement of a second body part and wherein the intended movement is a mental movement with little to no actual movement of the second body part;
    - determine the intended movement of the second body part using the first predetermined PPG signal pattern.
- 24.** The biosensor of claim **23**, wherein the processing device is configured to:
- process a second PPG signal at a second wavelength to identify a second fluctuation in the second PPG signal;
  - correlate the second motion artifact in the second PPG signal to a second predetermined PPG signal pattern, wherein the second predetermined PPG signal pattern is associated with the same intended movement of the second body part; and
  - determine the intended movement of the second body part using the first predetermined PPG signal pattern and the second predetermined PPG signal pattern.
- 25.** The biosensor of claim **23**, wherein the processing circuit is configured to:
- determine a heart rate signal from the first PPG signal;
  - determine a quality factor of the heart rate signal;
  - when the quality factor exceeds a predetermined threshold, identify the fluctuation in the first PPG signal.
- 26.** The biosensor of claim **23**, wherein the processing device is further configured to:
- process the PPG signal to identify a level of vasodilation; and
  - determine the intended movement of the second body part using the predetermined PPG signal pattern and using the level of vasodilation.
- 27.** The biosensor of claim **23**, further comprising:
- an earpiece configured for insertion in an ear canal, wherein the sensor is included within the earpiece and is configured to emit light into the ear canal and detect light reflected from the ear canal to obtain the PPG signal; and
  - wherein the first motion data for the second body part includes a facial movement or a facial expression.
- 28.** The biosensor of claim **23**, wherein the processing device is further configured to:

obtain another PPG signal, wherein the another PPG signal includes a spectral response around a second wavelength of light in a visible light range;  
analyze the another PPG signal to detect a change in skin color; and  
obtain the first motion data for the second body part using the predetermined PPG signal pattern and using the change in skin color.

**29.** The biosensor of claim **23**, wherein the processing device is further configured to:

identify an initial fluctuation in the PPG signal in response to neural activity prior to the motion artifact; and  
determine the intended movement of the body part using the predetermined PPG signal pattern and using the initial fluctuation in the PPG signal.

**30.** The biosensor of claim **23**, wherein the processing device is further configured to:

determine a duration and tension in one or more muscles using the PPG signal; and  
determine a stress level using the duration and tension in one or more muscles.

\* \* \* \* \*

专利名称(译)	使用PPG传感器进行运动检测的系统和方法		
公开(公告)号	<a href="#">US20190286233A1</a>	公开(公告)日	2019-09-19
申请号	US16/103876	申请日	2018-08-14
[标]申请(专利权)人(译)	桑米纳公司		
申请(专利权)人(译)	新美亚股份有限公司		
当前申请(专利权)人(译)	新美亚股份有限公司		
[标]发明人	NEWBERRY ROBERT		
发明人	NEWBERRY, ROBERT		
IPC分类号	G06F3/01 G06F3/03 G06K9/00 A61B5/00 A61B5/0488		
CPC分类号	G06K9/00355 A61B5/0075 G06F3/0304 A61B5/7475 G06F3/015 A61B5/0488 A61B5/6825 G06F3/014 A61B5/725 G06F1/163 G06F3/017 A61B5/02416 A61B5/1114 A61B2562/0219 G06F1/169 G06F1/1694		
优先权	62/675151 2018-05-22 US 62/643643 2018-03-15 US		
其他公开文献	US10466783		
外部链接	<a href="#">Espacenet</a> <a href="#">USPTO</a>		

摘要(译)

光电容积脉搏波 ( PPG ) 电路获得一个或多个波长的PPG信号。处理 PPG信号以识别运动伪影。运动伪影与与身体部位的运动相关联的预定 PPG信号模式相关。因此，PPG信号可用于检测身体部位的运动。可以响应于检测到的身体部位的移动来控制用户设备。

