



(19) **United States**

(12) **Patent Application Publication**
ZHANG

(10) **Pub. No.: US 2018/0064949 A1**
(43) **Pub. Date: Mar. 8, 2018**

(54) **METHOD AND APPARATUS FOR DISCRIMINATING TACHYCARDIA EVENTS IN A MEDICAL DEVICE USING TWO SENSING VECTORS**

(52) **U.S. Cl.**
CPC *A61N 1/3987* (2013.01); *A61B 5/04011* (2013.01); *A61B 5/0422* (2013.01); *A61B 5/04525* (2013.01); *A61B 5/7207* (2013.01); *A61B 5/0464* (2013.01); *A61B 5/046* (2013.01)

(71) Applicant: **Medtronic, Inc.**, Minneapolis, MN (US)

(72) Inventor: **Xusheng ZHANG**, Shoreview, MN (US)

(57) **ABSTRACT**

(21) Appl. No.: **15/801,522**

(22) Filed: **Nov. 2, 2017**

Related U.S. Application Data

(63) Continuation of application No. 14/250,040, filed on Apr. 10, 2014, now Pat. No. 9,808,640.

Publication Classification

(51) **Int. Cl.**
A61N 1/39 (2006.01)
A61B 5/04 (2006.01)
A61B 5/042 (2006.01)
A61B 5/0452 (2006.01)
A61B 5/046 (2006.01)
A61B 5/0464 (2006.01)
A61B 5/00 (2006.01)

A method and medical device for detecting a cardiac event that includes sensing cardiac signals from a plurality of electrodes forming a first sensing vector sensing a first interval of the cardiac signal during a predetermined time period and a second sensing vector simultaneously sensing a second interval of the cardiac signal during the predetermined time period, identifying each of the first interval and the second interval as being one of shockable and not shockable in response to first processing of the first interval and the second interval and in response to second processing of one or both of the first interval and the second interval, the second processing being different from the first processing, and determining whether to deliver therapy for the cardiac event in response to identifying each of the first interval and the second interval as being one of shockable and not shockable in response to both the first processing and the second processing of the first interval and the second interval.

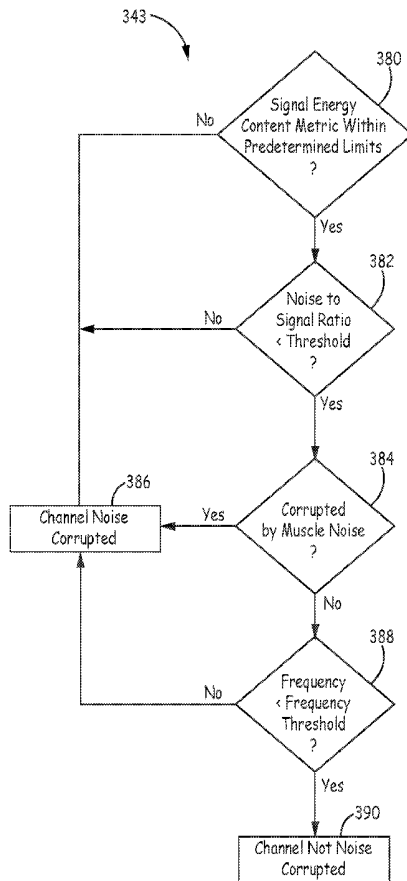

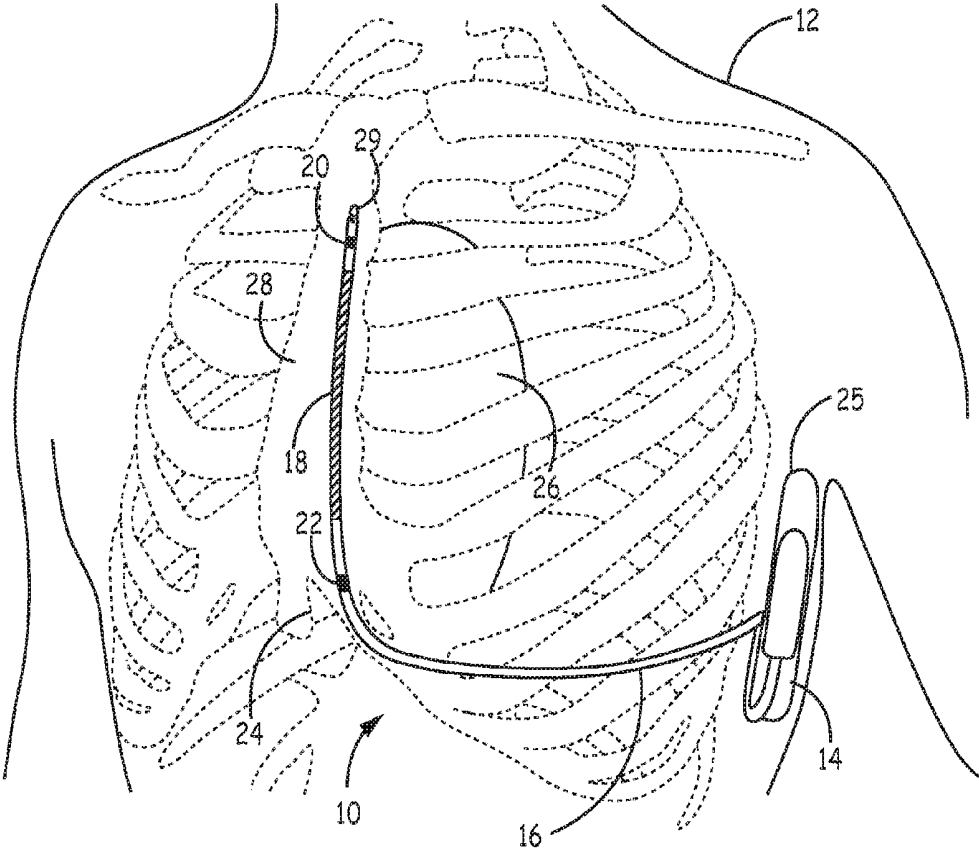

FIG. 1

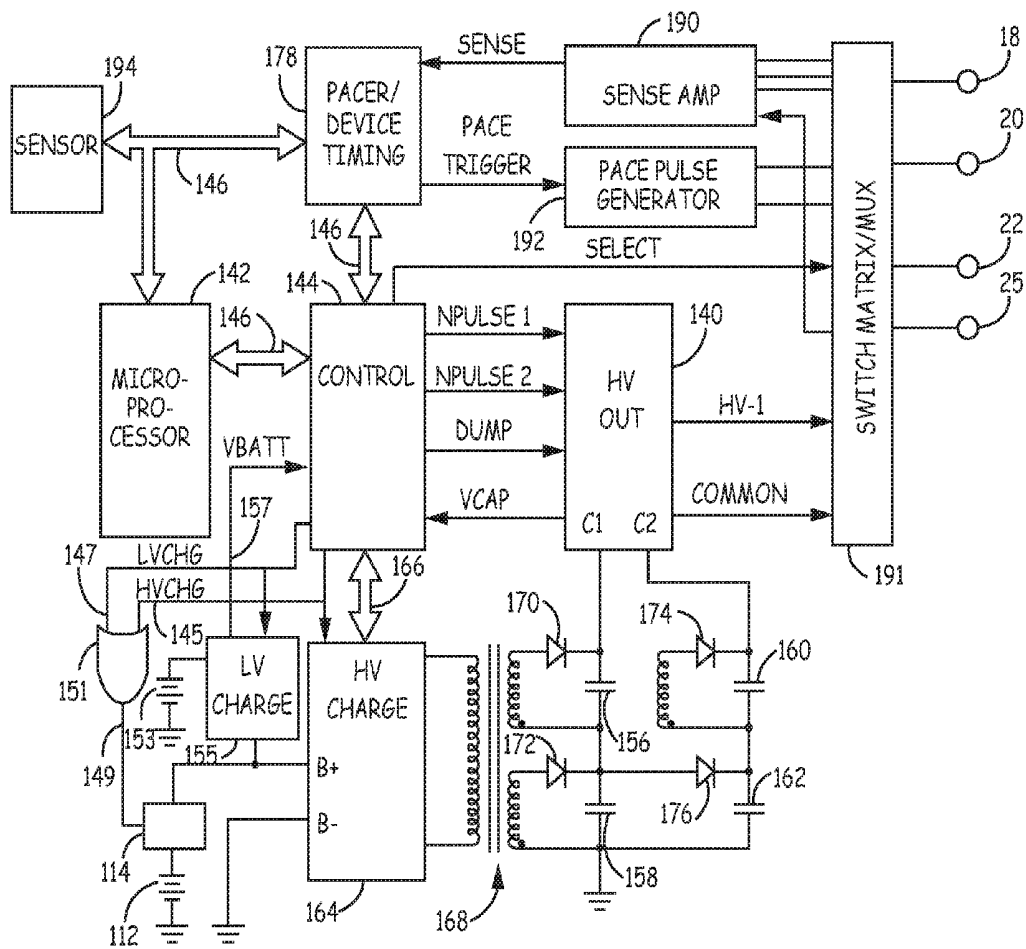

FIG. 2

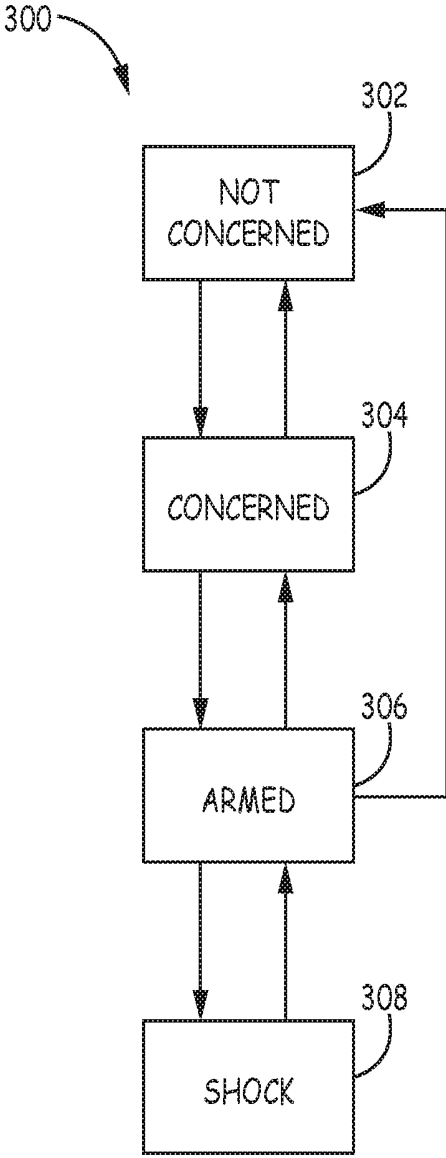

FIG. 3

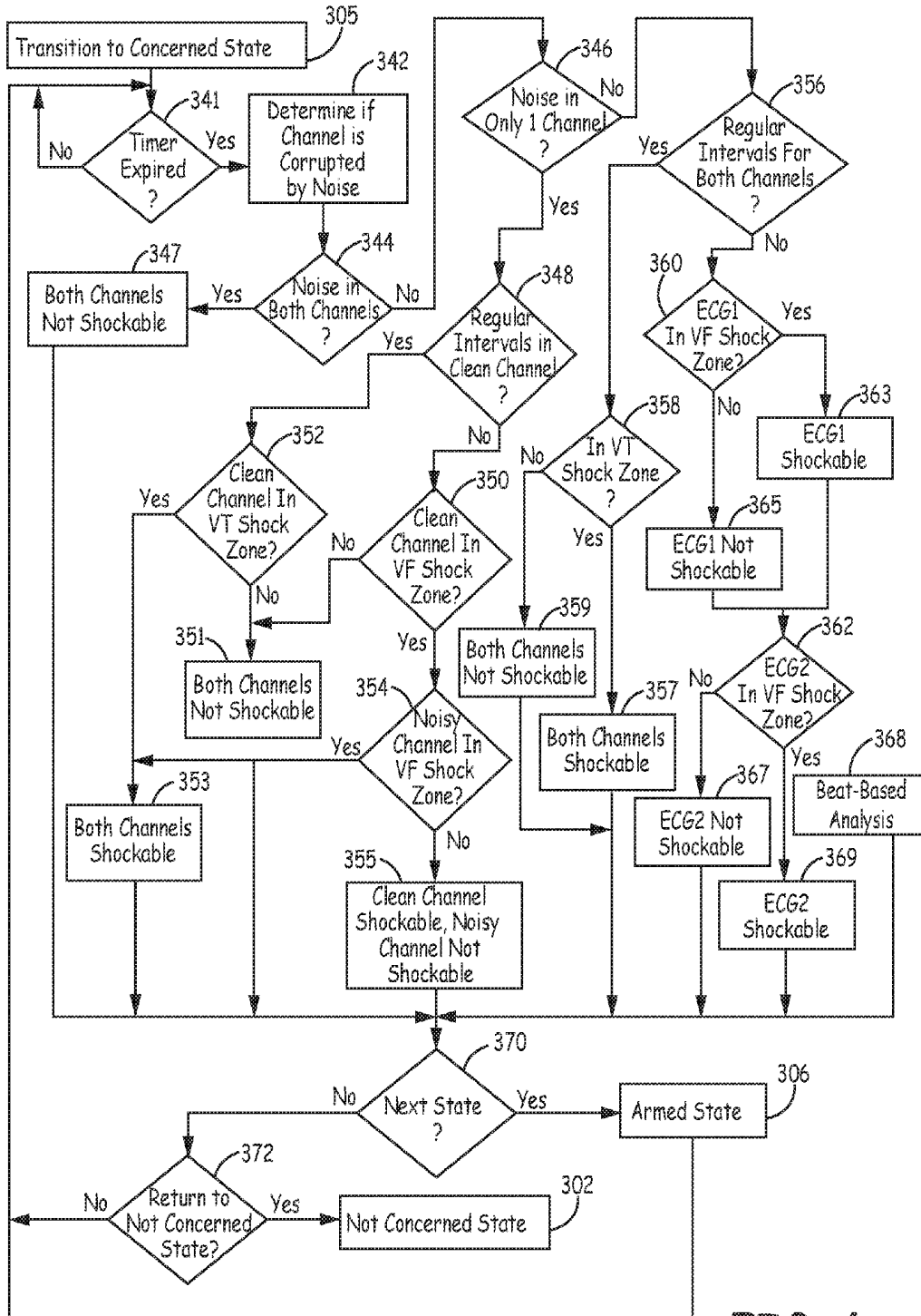

FIG. 4

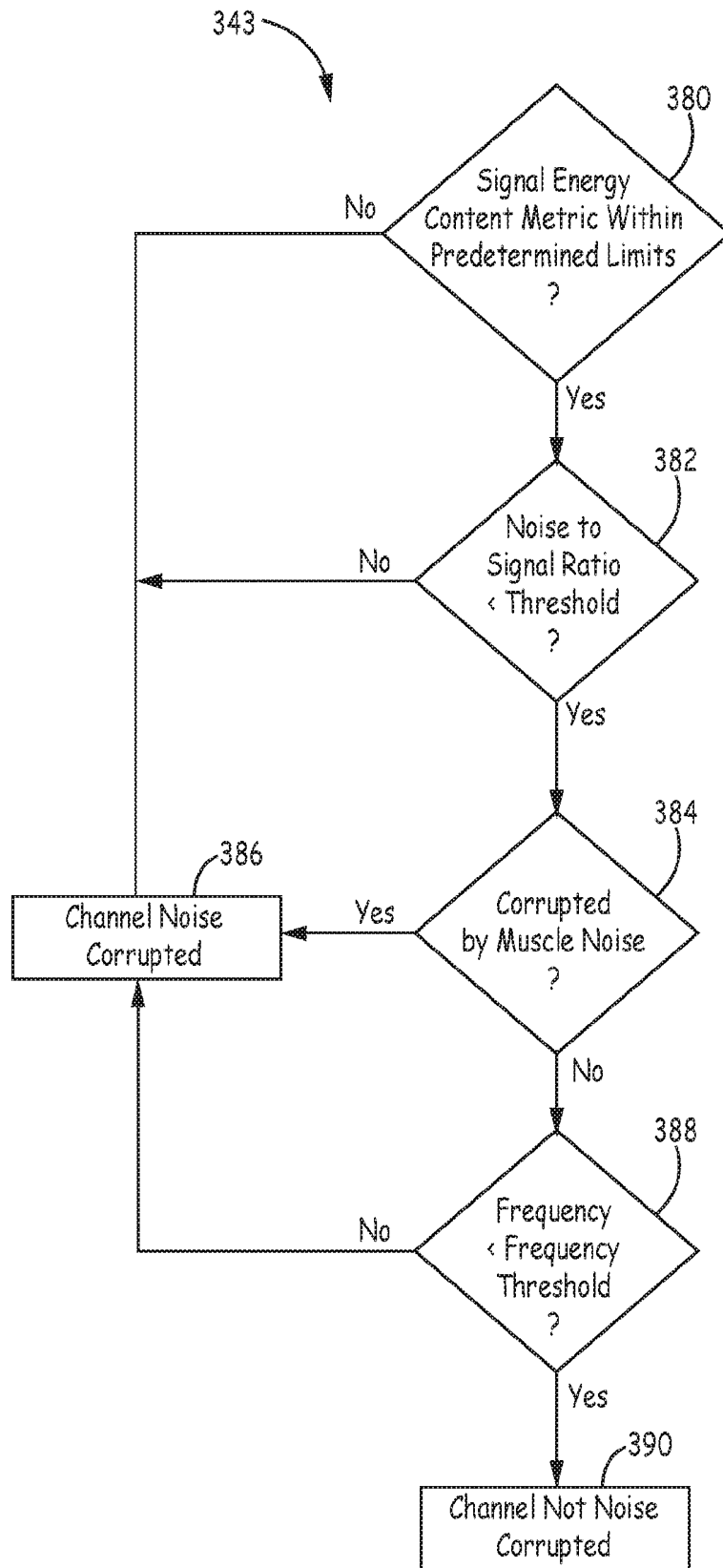

FIG. 5

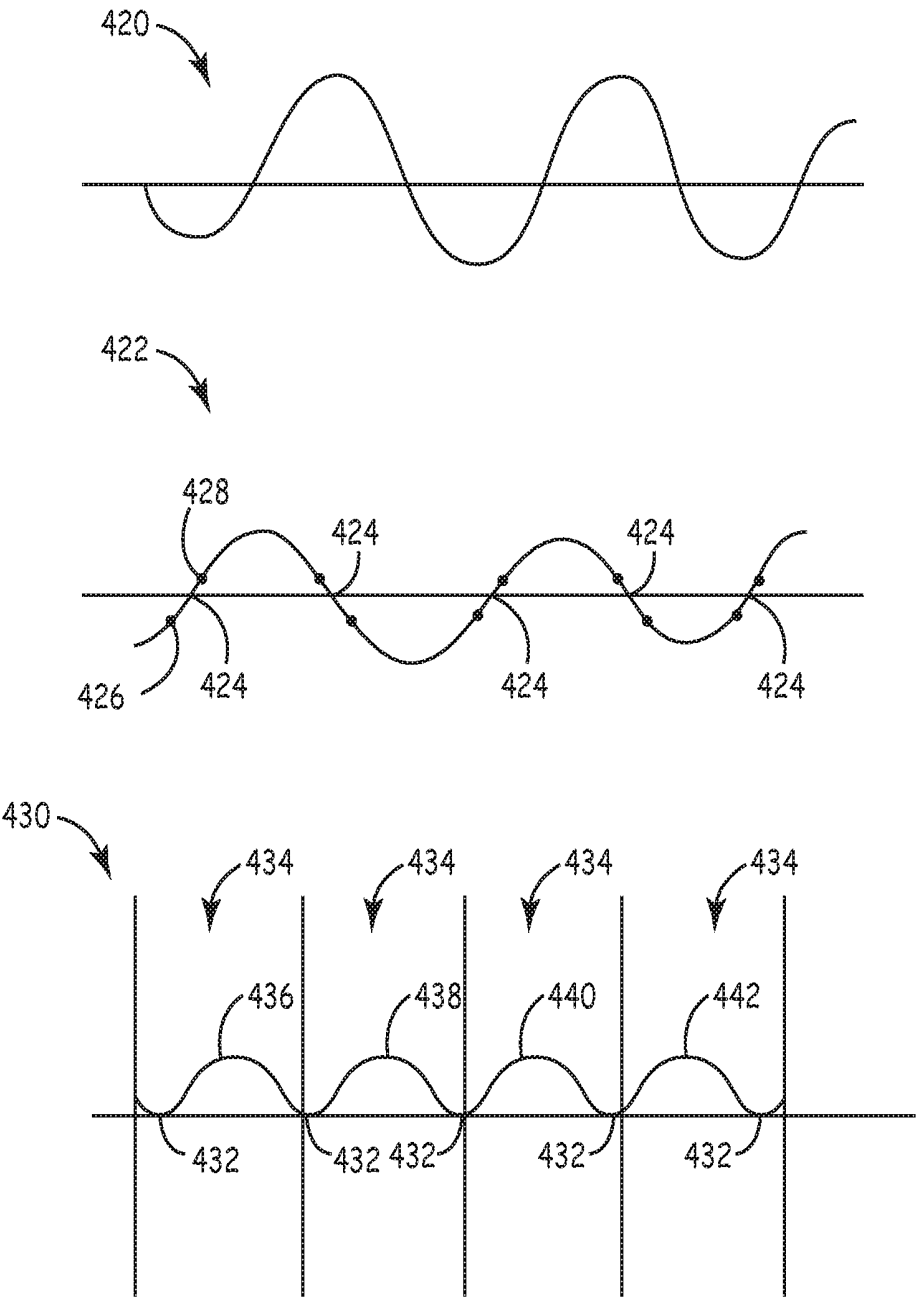

FIG. 6A

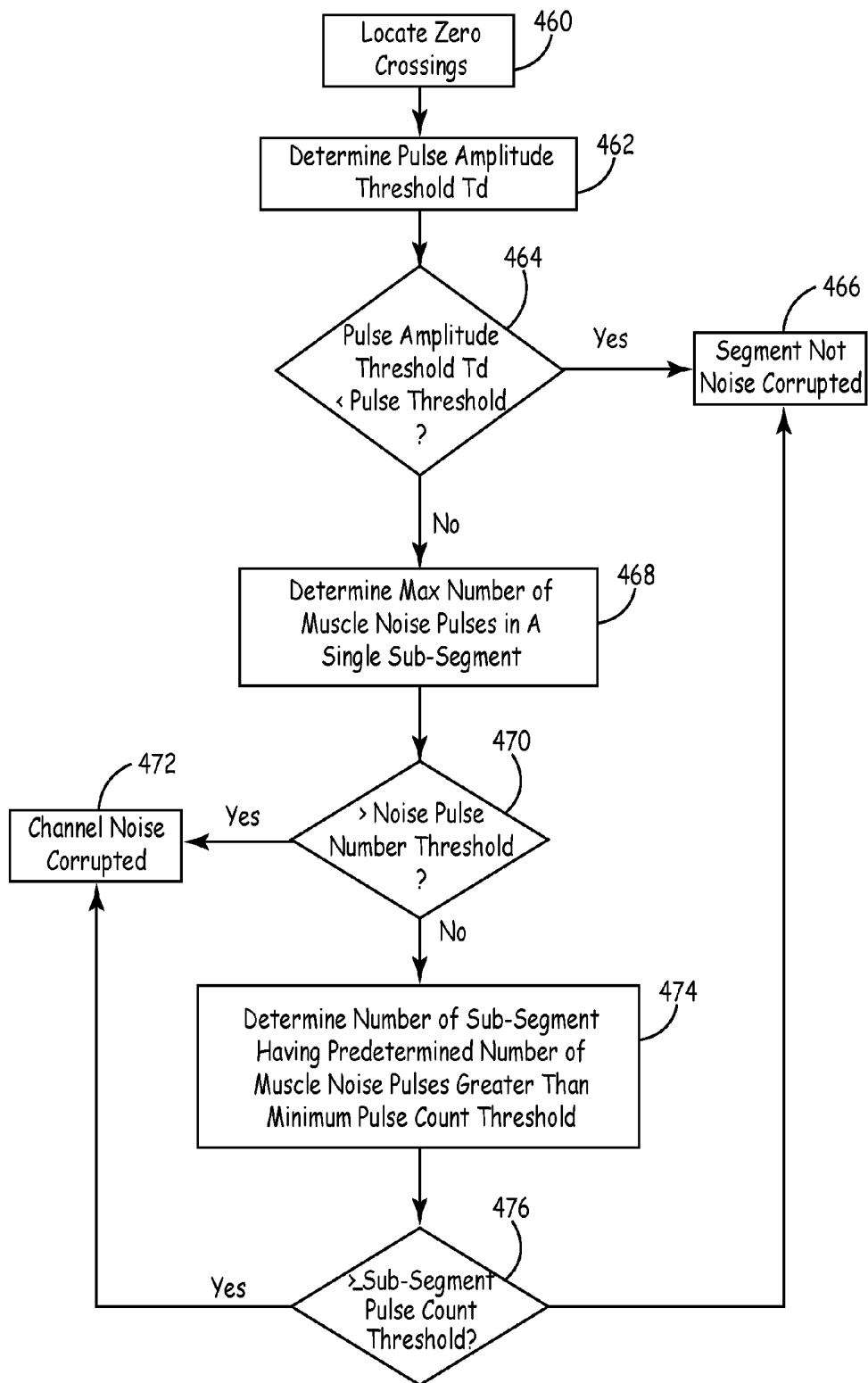

FIG. 6B

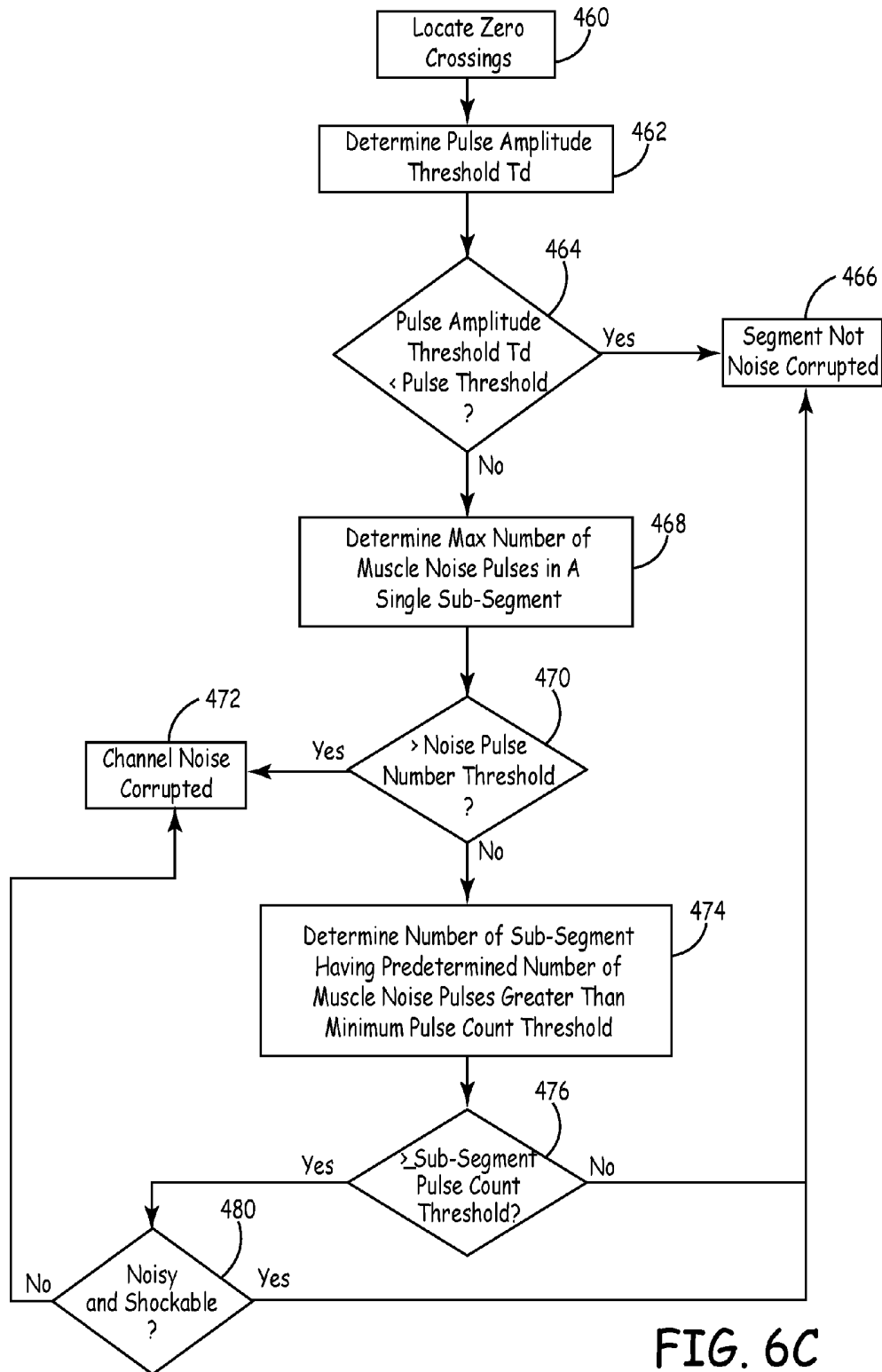

FIG. 6C

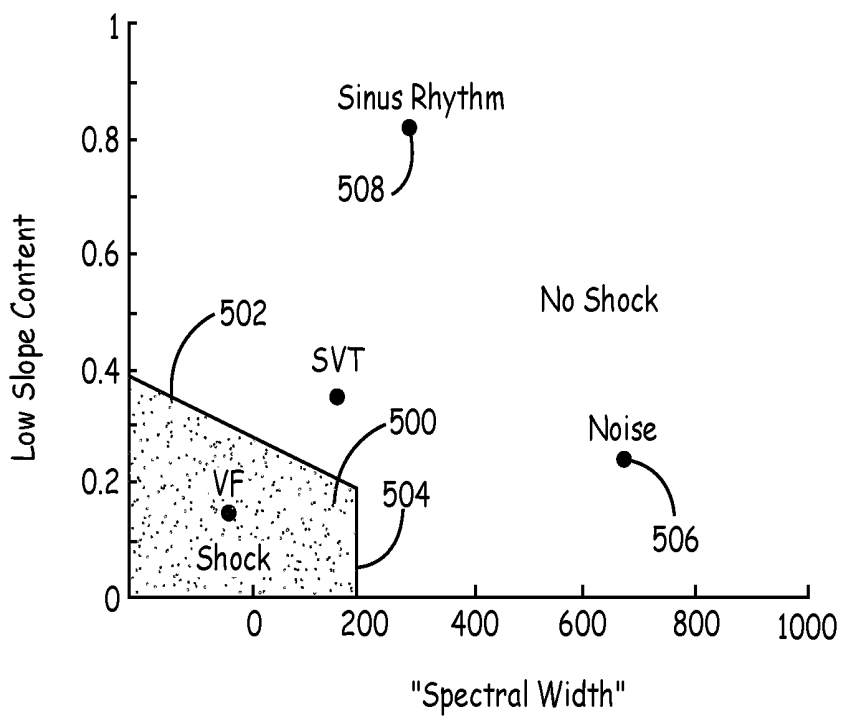

FIG. 7

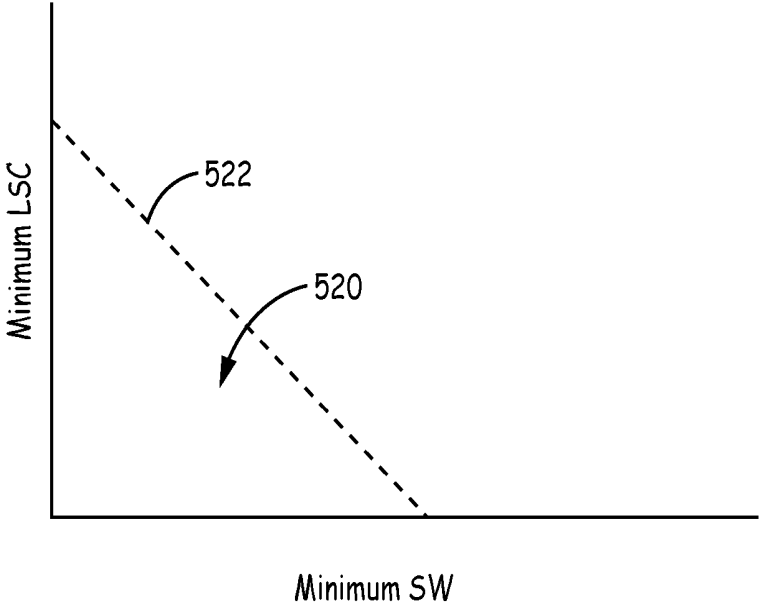

FIG. 8A

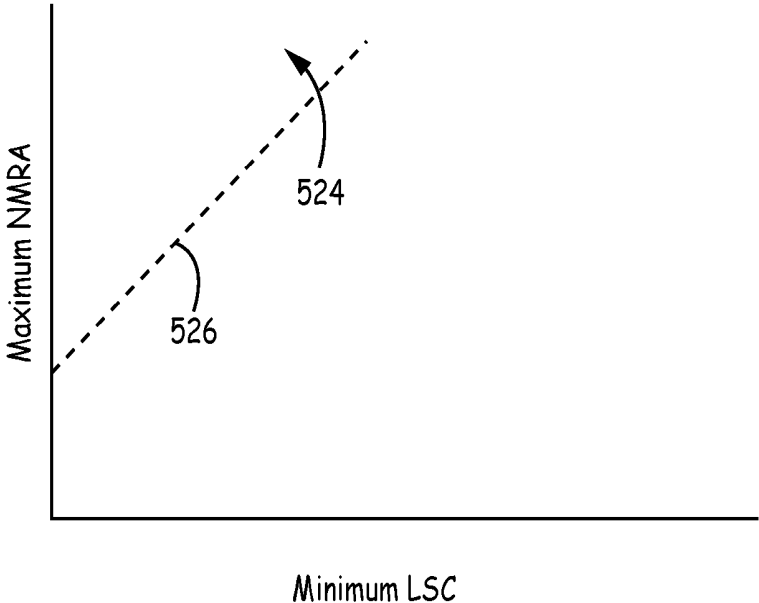

FIG. 8B

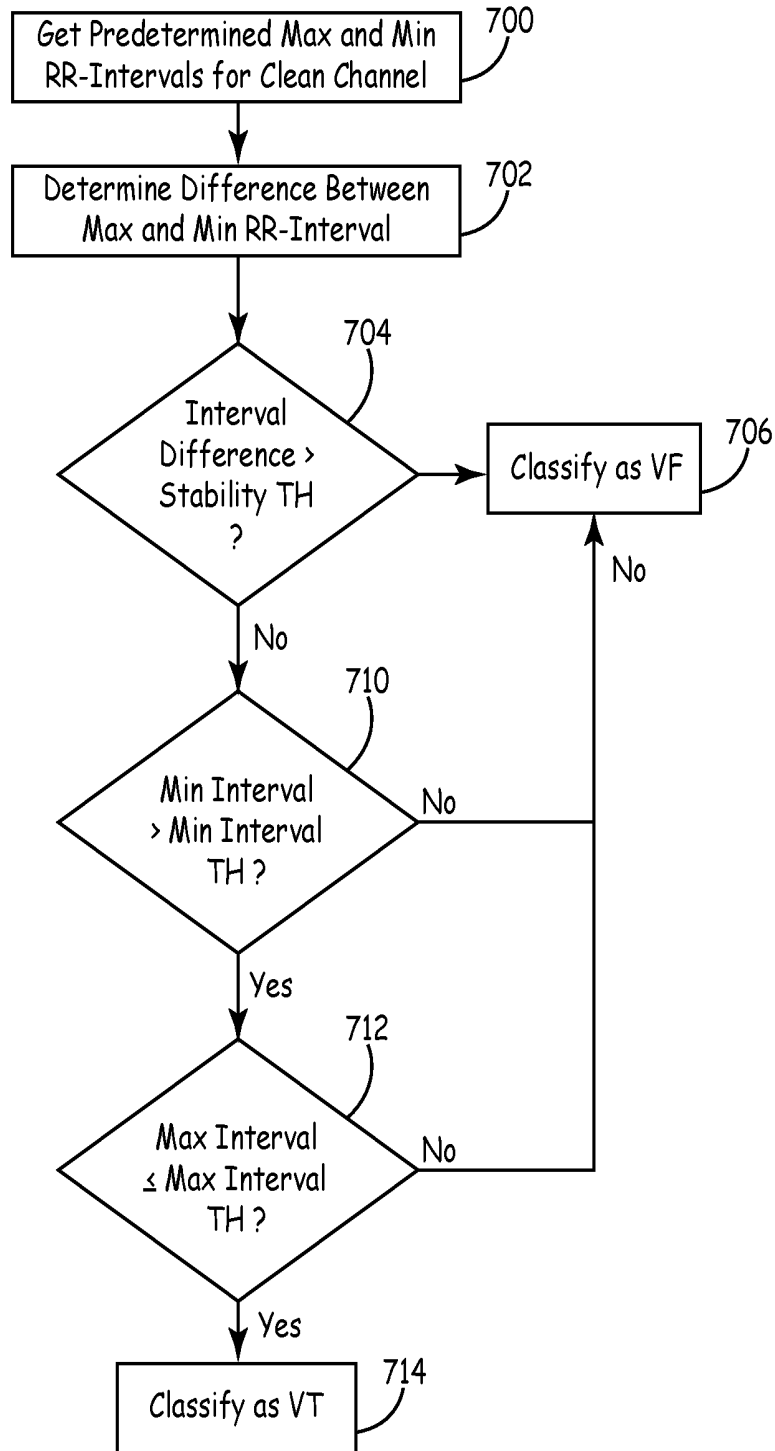

FIG. 9

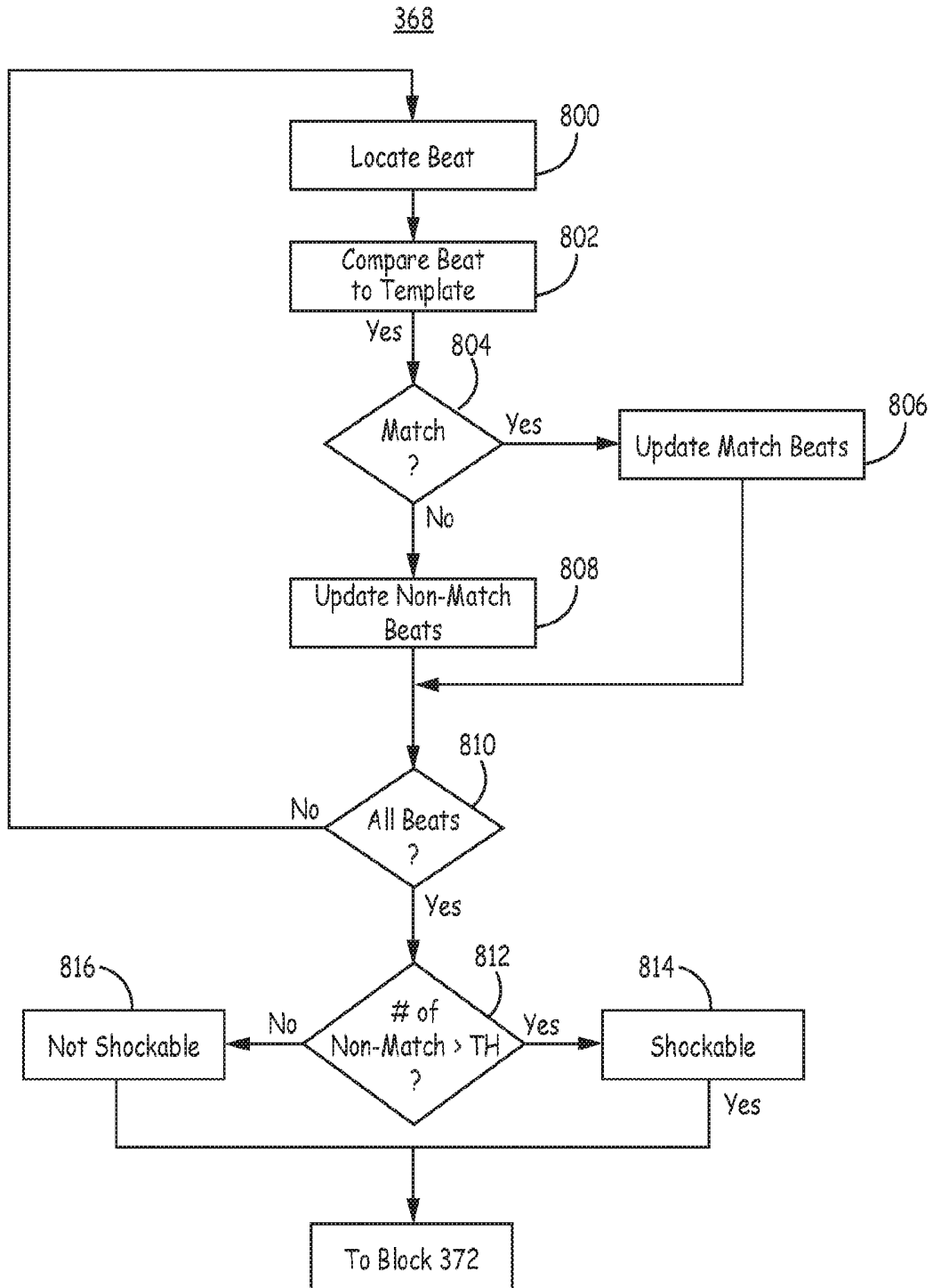

FIG. 10

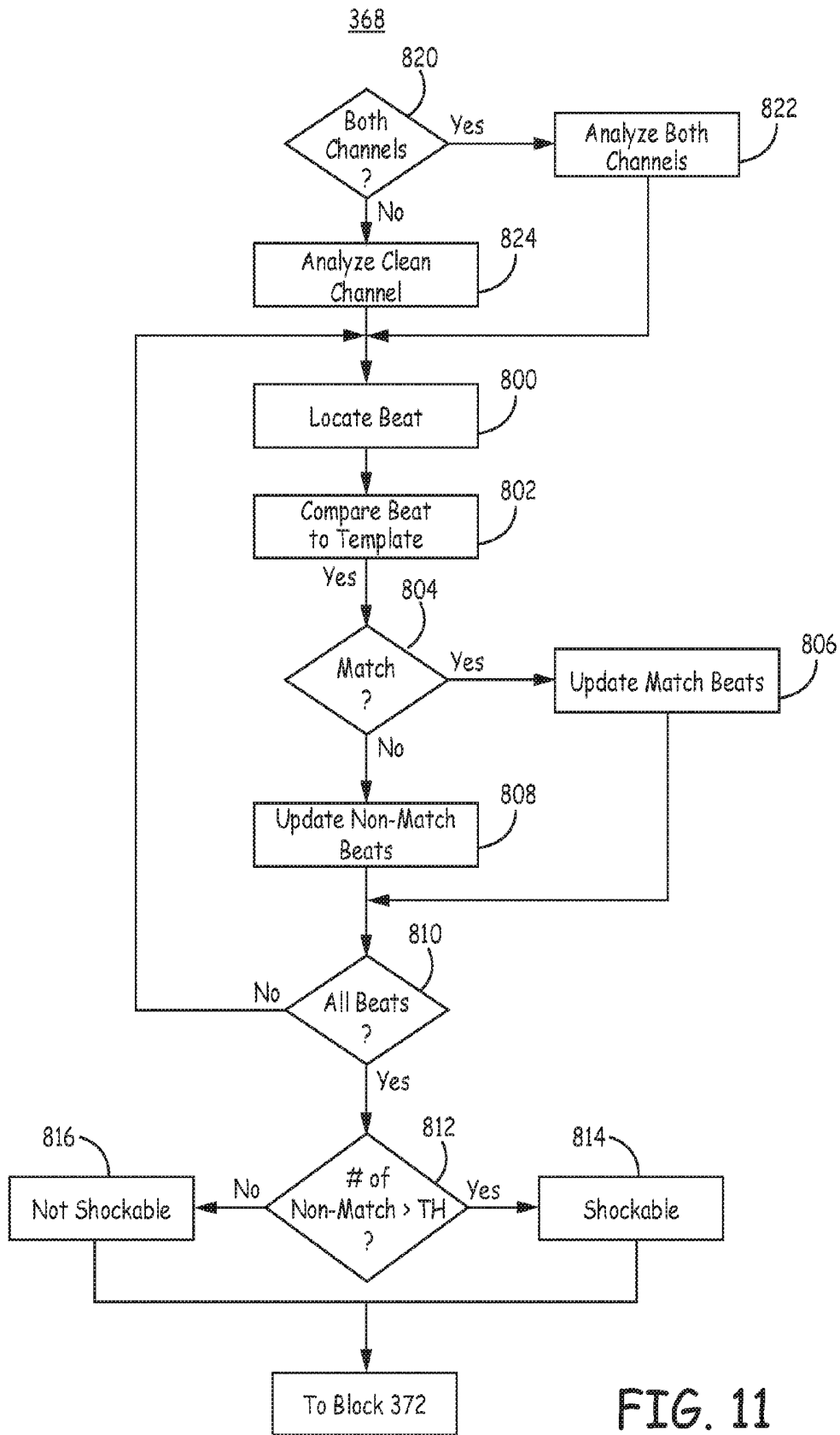

FIG. 11

**METHOD AND APPARATUS FOR
DISCRIMINATING TACHYCARDIA EVENTS
IN A MEDICAL DEVICE USING TWO
SENSING VECTORS**

[0001] This application is a continuation of U.S. patent application Ser. No. 14/250,040 filed Apr. 10, 2014 (granting as U.S. Pat. No. 9,808,640), the content of which is incorporated herein by reference in its entirety.

TECHNICAL FIELD

[0002] The disclosure relates generally to implantable medical devices and, in particular, to an apparatus and method for discriminating arrhythmias and delivering a therapy in a medical device.

BACKGROUND

[0003] Implantable medical devices are available for treating cardiac tachyarrhythmias by delivering anti-tachycardia pacing therapies and electrical shock therapies for cardioverting or defibrillating the heart. Such a device, commonly known as an implantable cardioverter defibrillator or "ICD", senses electrical activity from the heart, determines a patient's heart rate, and classifies the rate according to a number of heart rate zones in order to detect episodes of ventricular tachycardia or fibrillation. Typically a number of rate zones are defined according to programmable detection interval ranges for detecting slow ventricular tachycardia, fast ventricular tachycardia and ventricular fibrillation. Intervals between sensed R-waves, corresponding to the depolarization of the ventricles, are measured. Sensed R-R intervals falling into defined detection interval ranges are counted to provide a count of ventricular tachycardia (VT) or ventricular fibrillation (VF) intervals, for example. A programmable number of intervals to detect (NID) defines the number of tachycardia intervals occurring consecutively or out of a given number of preceding event intervals that are required to detect VT or VF.

[0004] Tachyarrhythmia detection may begin with detecting a fast ventricular rate, referred to as rate- or interval-based detection. Once VT or VF is detected based on rate, the morphology of the sensed depolarization signals, e.g. wave shape, amplitude or other features, may be used in discriminating heart rhythms to improve the sensitivity and specificity of tachyarrhythmia detection methods.

[0005] A primary goal of a tachycardia detection algorithm is to rapidly respond to a potentially malignant rhythm with a therapy that will terminate the arrhythmia with high certainty. Another goal, however, is to avoid excessive use of ICD battery charge, which shortens the life of the ICD, e.g. due to delivering unnecessary therapies or therapies at a higher voltage than needed to terminate a detected tachyarrhythmia. Minimizing the patient's exposure to painful shock therapies is also an important consideration. Accordingly, a need remains for ICDs that perform tachycardia discrimination with high specificity and control therapy delivery to successfully terminate a detected VT requiring therapy while conserving battery charge and limiting patient exposure to delivered shock therapy by withholding therapy delivery whenever possible in situations where the therapy may not be required.

BRIEF DESCRIPTION OF THE DRAWINGS

[0006] FIG. 1 is a conceptual diagram of a patient implanted with an example extravascular cardiac defibrillation system.

[0007] FIG. 2 is an exemplary schematic diagram of electronic circuitry within a hermetically sealed housing of a subcutaneous device according to an embodiment of the present invention.

[0008] FIG. 3 is a state diagram of detection of arrhythmias in a medical device according to an embodiment of the present invention.

[0009] FIG. 4 is a flowchart of a method for detecting arrhythmias in a subcutaneous device according to an embodiment of the present disclosure.

[0010] FIG. 5 is a flowchart of a method of determining noise according to an embodiment of the present disclosure.

[0011] FIG. 6A is a graphical representation of a determination of whether a signal is corrupted by muscle noise according to an embodiment of the present invention.

[0012] FIG. 6B is a flowchart of a method of determining whether a signal is corrupted by muscle noise according to an embodiment of the present invention.

[0013] FIG. 6C is a flowchart of a method of determining whether a signal is corrupted by muscle noise according to an embodiment of the present invention.

[0014] FIG. 7 is a graphical representation of a VF shock zone according to an embodiment of the present invention.

[0015] FIGS. 8A and 8B are graphical representations of the determination of whether an event is within a shock zone according to an embodiment of the present invention.

[0016] FIG. 9 is a flowchart of a method for discriminating cardiac events according to an embodiment of the disclosure.

[0017] FIG. 10 is a flowchart of a beat-based analysis during detection of arrhythmias in a medical device according to an embodiment of the present disclosure.

[0018] FIG. 11 is a flowchart of a beat-based analysis during detection of arrhythmias in a medical device according to an embodiment of the present disclosure.

DETAILED DESCRIPTION

[0019] FIG. 1 is a conceptual diagram of a patient 12 implanted with an example extravascular cardiac defibrillation system 10. In the example illustrated in FIG. 1, extravascular cardiac defibrillation system 10 is an implanted subcutaneous ICD system. However, the techniques of this disclosure may also be utilized with other extravascular implanted cardiac defibrillation systems, such as a cardiac defibrillation system having a lead implanted at least partially in a substernal or submuscular location. Additionally, the techniques of this disclosure may also be utilized with other implantable systems, such as implantable pacing systems, implantable neurostimulation systems, drug delivery systems or other systems in which leads, catheters or other components are implanted at extravascular locations within patient 12. This disclosure, however, is described in the context of an implantable extravascular cardiac defibrillation system for purposes of illustration.

[0020] Extravascular cardiac defibrillation system 10 includes an implantable cardioverter defibrillator (ICD) 14 connected to at least one implantable cardiac defibrillation lead 16. ICD 14 of FIG. 1 is implanted subcutaneously on the left side of patient 12. Defibrillation lead 16, which is

connected to ICD 14, extends medially from ICD 14 toward sternum 28 and xiphoid process 24 of patient 12. At a location near xiphoid process 24, defibrillation lead 16 bends or turns and extends subcutaneously superior, substantially parallel to sternum 28. In the example illustrated in FIG. 1, defibrillation lead 16 is implanted such that lead 16 is offset laterally to the left side of the body of sternum 28 (i.e., towards the left side of patient 12).

[0021] Defibrillation lead 16 is placed along sternum 28 such that a therapy vector between defibrillation electrode 18 and a second electrode (such as a housing or can 25 of ICD 14 or an electrode placed on a second lead) is substantially across the ventricle of heart 26. The therapy vector may, in one example, be viewed as a line that extends from a point on the defibrillation electrode 18 to a point on the housing or can 25 of ICD 14. In another example, defibrillation lead 16 may be placed along sternum 28 such that a therapy vector between defibrillation electrode 18 and the housing or can 25 of ICD 14 (or other electrode) is substantially across an atrium of heart 26. In this case, extravascular ICD system 10 may be used to provide atrial therapies, such as therapies to treat atrial fibrillation.

[0022] The embodiment illustrated in FIG. 1 is an example configuration of an extravascular ICD system 10 and should not be considered limiting of the techniques described herein. For example, although illustrated as being offset laterally from the midline of sternum 28 in the example of FIG. 1, defibrillation lead 16 may be implanted such that lead 16 is offset to the right of sternum 28 or more centrally located over sternum 28. Additionally, defibrillation lead 16 may be implanted such that it is not substantially parallel to sternum 28, but instead offset from sternum 28 at an angle (e.g., angled lateral from sternum 28 at either the proximal or distal end). As another example, the distal end of defibrillation lead 16 may be positioned near the second or third rib of patient 12. However, the distal end of defibrillation lead 16 may be positioned further superior or inferior depending on the location of ICD 14, location of electrodes 18, 20, and 22, or other factors.

[0023] Although ICD 14 is illustrated as being implanted near a midaxillary line of patient 12, ICD 14 may also be implanted at other subcutaneous locations on patient 12, such as further posterior on the torso toward the posterior axillary line, further anterior on the torso toward the anterior axillary line, in a pectoral region, or at other locations of patient 12. In instances in which ICD 14 is implanted pectorally, lead 16 would follow a different path, e.g., across the upper chest area and inferior along sternum 28. When the ICD 14 is implanted in the pectoral region, the extravascular ICD system may include a second lead including a defibrillation electrode that extends along the left side of the patient such that the defibrillation electrode of the second lead is located along the left side of the patient to function as an anode or cathode of the therapy vector of such an ICD system.

[0024] ICD 14 includes a housing or can 25 that forms a hermetic seal that protects components within ICD 14. The housing 25 of ICD 14 may be formed of a conductive material, such as titanium or other biocompatible conductive material or a combination of conductive and non-conductive materials. In some instances, the housing 25 of ICD 14 functions as an electrode (referred to as a housing electrode or can electrode) that is used in combination with one of electrodes 18, 20, or 22 to deliver a therapy to heart 26 or to

sense electrical activity of heart 26. ICD 14 may also include a connector assembly (sometimes referred to as a connector block or header) that includes electrical feedthroughs through which electrical connections are made between conductors within defibrillation lead 16 and electronic components included within the housing. Housing may enclose one or more components, including processors, memories, transmitters, receivers, sensors, sensing circuitry, therapy circuitry and other appropriate components (often referred to herein as modules).

[0025] Defibrillation lead 16 includes a lead body having a proximal end that includes a connector configured to connect to ICD 14 and a distal end that includes one or more electrodes 18, 20, and 22. The lead body of defibrillation lead 16 may be formed from a non-conductive material, including silicone, polyurethane, fluoropolymers, mixtures thereof, and other appropriate materials, and shaped to form one or more lumens within which the one or more conductors extend. However, the techniques are not limited to such constructions. Although defibrillation lead 16 is illustrated as including three electrodes 18, 20 and 22, defibrillation lead 16 may include more or fewer electrodes.

[0026] Defibrillation lead 16 includes one or more elongated electrical conductors (not illustrated) that extend within the lead body from the connector on the proximal end of defibrillation lead 16 to electrodes 18, 20 and 22. In other words, each of the one or more elongated electrical conductors contained within the lead body of defibrillation lead 16 may engage with respective ones of electrodes 18, 20 and 22. When the connector at the proximal end of defibrillation lead 16 is connected to ICD 14, the respective conductors may electrically couple to circuitry, such as a therapy module or a sensing module, of ICD 14 via connections in connector assembly, including associated feedthroughs. The electrical conductors transmit therapy from a therapy module within ICD 14 to one or more of electrodes 18, 20 and 22 and transmit sensed electrical signals from one or more of electrodes 18, 20 and 22 to the sensing module within ICD 14.

[0027] ICD 14 may sense electrical activity of heart 26 via one or more sensing vectors that include combinations of electrodes 20 and 22 and the housing or can 25 of ICD 14. For example, ICD 14 may obtain electrical signals sensed using a sensing vector between electrodes 20 and 22, obtain electrical signals sensed using a sensing vector between electrode 20 and the conductive housing or can 25 of ICD 14, obtain electrical signals sensed using a sensing vector between electrode 22 and the conductive housing or can 25 of ICD 14, or a combination thereof. In some instances, ICD 14 may sense cardiac electrical signals using a sensing vector that includes defibrillation electrode 18, such as a sensing vector between defibrillation electrode 18 and one of electrodes 20 or 22, or a sensing vector between defibrillation electrode 18 and the housing or can 25 of ICD 14.

[0028] ICD may analyze the sensed electrical signals to detect tachycardia, such as ventricular tachycardia or ventricular fibrillation, and in response to detecting tachycardia may generate and deliver an electrical therapy to heart 26. For example, ICD 14 may deliver one or more defibrillation shocks via a therapy vector that includes defibrillation electrode 18 of defibrillation lead 16 and the housing or can 25. Defibrillation electrode 18 may, for example, be an elongated coil electrode or other type of electrode. In some instances, ICD 14 may deliver one or more pacing therapies

prior to or after delivery of the defibrillation shock, such as anti-tachycardia pacing (ATP) or post shock pacing. In these instances, ICD 14 may generate and deliver pacing pulses via therapy vectors that include one or both of electrodes 20 and 22 and/or the housing or can 25. Electrodes 20 and 22 may comprise ring electrodes, hemispherical electrodes, coil electrodes, helix electrodes, segmented electrodes, directional electrodes, or other types of electrodes, or combination thereof. Electrodes 20 and 22 may be the same type of electrodes or different types of electrodes, although in the example of FIG. 1 both electrodes 20 and 22 are illustrated as ring electrodes.

[0029] Defibrillation lead 16 may also include an attachment feature 29 at or toward the distal end of lead 16. The attachment feature 29 may be a loop, link, or other attachment feature. For example, attachment feature 29 may be a loop formed by a suture. As another example, attachment feature 29 may be a loop, link, ring of metal, coated metal or a polymer. The attachment feature 29 may be formed into any of a number of shapes with uniform or varying thickness and varying dimensions. Attachment feature 29 may be integral to the lead or may be added by the user prior to implantation. Attachment feature 29 may be useful to aid in implantation of lead 16 and/or for securing lead 16 to a desired implant location. In some instances, defibrillation lead 16 may include a fixation mechanism in addition to or instead of the attachment feature. Although defibrillation lead 16 is illustrated with an attachment feature 29, in other examples lead 16 may not include an attachment feature 29.

[0030] Lead 16 may also include a connector at the proximal end of lead 16, such as a DF4 connector, bifurcated connector (e.g., DF-1/IS-1 connector), or other type of connector. The connector at the proximal end of lead 16 may include a terminal pin that couples to a port within the connector assembly of ICD 14. In some instances, lead 16 may include an attachment feature at the proximal end of lead 16 that may be coupled to an implant tool to aid in implantation of lead 16. The attachment feature at the proximal end of the lead may separate from the connector and may be either integral to the lead or added by the user prior to implantation.

[0031] Defibrillation lead 16 may also include a suture sleeve or other fixation mechanism (not shown) located proximal to electrode 22 that is configured to fixate lead 16 near the xiphoid process or lower sternum location. The fixation mechanism (e.g., suture sleeve or other mechanism) may be integral to the lead or may be added by the user prior to implantation.

[0032] The example illustrated in FIG. 1 is exemplary in nature and should not be considered limiting of the techniques described in this disclosure. For instance, extravascular cardiac defibrillation system 10 may include more than one lead. In one example, extravascular cardiac defibrillation system 10 may include a pacing lead in addition to defibrillation lead 16.

[0033] In the example illustrated in FIG. 1, defibrillation lead 16 is implanted subcutaneously, e.g., between the skin and the ribs or sternum. In other instances, defibrillation lead 16 (and/or the optional pacing lead) may be implanted at other extravascular locations. In one example, defibrillation lead 16 may be implanted at least partially in a substernal location. In such a configuration, at least a portion of defibrillation lead 16 may be placed under or below the sternum in the mediastinum and, more particularly, in the

anterior mediastinum. The anterior mediastinum is bounded laterally by pleurae, posteriorly by pericardium, and anteriorly by sternum 28. Defibrillation lead 16 may be at least partially implanted in other extra-pericardial locations, i.e., locations in the region around, but not in direct contact with, the outer surface of heart 26. These other extra-pericardial locations may include in the mediastinum but offset from sternum 28, in the superior mediastinum, in the middle mediastinum, in the posterior mediastinum, in the sub-xiphoid or inferior xiphoid area, near the apex of the heart, or other location not in direct contact with heart 26 and not subcutaneous. In still further instances, the lead may be implanted at a pericardial or epicardial location outside of the heart 26.

[0034] FIG. 2 is an exemplary schematic diagram of electronic circuitry within a hermetically sealed housing of a subcutaneous device according to an embodiment of the present invention. As illustrated in FIG. 2, subcutaneous device 14 includes a low voltage battery 153 coupled to a power supply (not shown) that supplies power to the circuitry of the subcutaneous device 14 and the pacing output capacitors to supply pacing energy in a manner well known in the art. The low voltage battery 153 may be formed of one or two conventional LiCF_x , LiMnO_2 or LiI_2 cells, for example. The subcutaneous device 14 also includes a high voltage battery 112 that may be formed of one or two conventional LiSVO or LiMnO_2 cells. Although two both low voltage battery and a high voltage battery are shown in FIG. 2, according to an embodiment of the present invention, the device 14 could utilize a single battery for both high and low voltage uses.

[0035] Further referring to FIG. 2, subcutaneous device 14 functions are controlled by means of software, firmware and hardware that cooperatively monitor the ECG signal, determine when a cardioversion-defibrillation shock or pacing is necessary, and deliver prescribed cardioversion-defibrillation and pacing therapies. The subcutaneous device 14 may incorporate circuitry set forth in commonly assigned U.S. Patent No. 5,163,427 "Apparatus for Delivering Single and Multiple Cardioversion and Defibrillation Pulses" to Keimel and U.S. Pat. No. 5,188,105 "Apparatus and Method for Treating a Tachyarrhythmia" to Keimel for selectively delivering single phase, simultaneous biphasic and sequential biphasic cardioversion-defibrillation shocks typically employing ICD IPG housing electrodes 28 coupled to the COMMON output 123 of high voltage output circuit 140 and cardioversion-defibrillation electrode 24 disposed posteriorly and subcutaneously and coupled to the HVI output 113 of the high voltage output circuit 140.

[0036] The cardioversion-defibrillation shock energy and capacitor charge voltages can be intermediate to those supplied by ICDs having at least one cardioversion-defibrillation electrode in contact with the heart and most AEDs having cardioversion-defibrillation electrodes in contact with the skin. The typical maximum voltage necessary for ICDs using most biphasic waveforms is approximately 750 Volts with an associated maximum energy of approximately 40 Joules. The typical maximum voltage necessary for AEDs is approximately 2000-5000 Volts with an associated maximum energy of approximately 200-360 Joules depending upon the model and waveform used. The subcutaneous device 14 of the present invention uses maximum voltages in the range of about 300 to approximately 1000 Volts and is associated with energies of approximately 25 to 150 joules

or more. The total high voltage capacitance could range from about 50 to about 300 microfarads. Such cardioversion-defibrillation shocks are only delivered when a malignant tachyarrhythmia, e.g., ventricular fibrillation is detected through processing of the far field cardiac ECG employing the detection algorithms as described herein below.

[0037] In FIG. 2, sense amp 190 in conjunction with pacer/device timing circuit 178 processes the far field ECG sense signal that is developed across a particular ECG sense vector defined by a selected pair of the subcutaneous electrodes 18, 20, 22 and the can or housing 25 of the device 14, or, optionally, a virtual signal (i.e., a mathematical combination of two vectors) if selected. The selection of the sensing electrode pair is made through the switch matrix/MUX 191 in a manner to provide the most reliable sensing of the ECG signal of interest, which would be the R wave for patients who are believed to be at risk of ventricular fibrillation leading to sudden death. The far field ECG signals are passed through the switch matrix/MUX 191 to the input of the sense amplifier 190 that, in conjunction with pacer/device timing circuit 178, evaluates the sensed EGM. Bradycardia, or asystole, is typically determined by an escape interval timer within the pacer timing circuit 178 and/or the control circuit 144. Pace Trigger signals are applied to the pacing pulse generator 192 generating pacing stimulation when the interval between successive R-waves exceeds the escape interval. Bradycardia pacing is often temporarily provided to maintain cardiac output after delivery of a cardioversion-defibrillation shock that may cause the heart to slowly beat as it recovers back to normal function. Sensing subcutaneous far field signals in the presence of noise may be aided by the use of appropriate denial and extensible accommodation periods as described in U.S. Pat. No. 6,236,882 "Noise Rejection for Monitoring ECGs" to Lee, et al and incorporated herein by reference in its entirety.

[0038] Detection of a malignant tachyarrhythmia is determined in the Control circuit 144 as a function of the intervals between R-wave sense event signals that are output from the pacer/device timing 178 and sense amplifier circuit 190 to the timing and control circuit 144. It should be noted that the present invention utilizes not only interval based signal analysis method but also supplemental sensors and morphology processing method and apparatus as described herein below.

[0039] Supplemental sensors such as tissue color, tissue oxygenation, respiration, patient activity and the like may be used to contribute to the decision to apply or withhold a defibrillation therapy as described generally in U.S. Pat. No. 5,464,434 "Medical Interventional Device Responsive to Sudden Hemodynamic Change" to Alt and incorporated herein by reference in its entirety. Sensor processing block 194 provides sensor data to microprocessor 142 via data bus 146. Specifically, patient activity and/or posture may be determined by the apparatus and method as described in U.S. Pat. No. 5,593,431 "Medical Service Employing Multiple DC Accelerometers for Patient Activity and Posture Sensing and Method" to Sheldon and incorporated herein by reference in its entirety. Patient respiration may be determined by the apparatus and method as described in U.S. Pat. No. 4,567,892 "Implantable Cardiac Pacemaker" to Plicchi, et al and incorporated herein by reference in its entirety. Patient tissue oxygenation or tissue color may be determined by the sensor apparatus and method as described in U.S. Pat.

No. 5,176,137 to Erickson, et al and incorporated herein by reference in its entirety. The oxygen sensor of the '137 patent may be located in the subcutaneous device pocket or, alternatively, located on the lead 18 to enable the sensing of contacting or near-contacting tissue oxygenation or color.

[0040] Certain steps in the performance of the detection algorithm criteria are cooperatively performed in microcomputer 142, including microprocessor, RAM and ROM, associated circuitry, and stored detection criteria that may be programmed into RAM via a telemetry interface (not shown) conventional in the art. Data and commands are exchanged between microcomputer 142 and timing and control circuit 144, pacer timing/amplifier circuit 178, and high voltage output circuit 140 via a bi-directional data/control bus 146. The pacer timing/amplifier circuit 178 and the control circuit 144 are clocked at a slow clock rate. The microcomputer 142 is normally asleep, but is awakened and operated by a fast clock by interrupts developed by each R-wave sense event, on receipt of a downlink telemetry programming instruction or upon delivery of cardiac pacing pulses to perform any necessary mathematical calculations, to perform tachycardia and fibrillation detection procedures, and to update the time intervals monitored and controlled by the timers in pacer/device timing circuitry 178.

[0041] When a malignant tachycardia is detected, high voltage capacitors 156, 158, 160, and 162 are charged to a pre-programmed voltage level by a high-voltage charging circuit 164. It is generally considered inefficient to maintain a constant charge on the high voltage output capacitors 156, 158, 160, 162.

[0042] Instead, charging is initiated when control circuit 144 issues a high voltage charge command HVCHG delivered on line 145 to high voltage charge circuit 164 and charging is controlled by means of bi-directional control/data bus 166 and a feedback signal VCAP from the HV output circuit 140. High voltage output capacitors 156, 158, 160 and 162 may be of film, aluminum electrolytic or wet tantalum construction.

[0043] The negative terminal of high voltage battery 112 is directly coupled to system ground. Switch circuit 114 is normally open so that the positive terminal of high voltage battery 112 is disconnected from the positive power input of the high voltage charge circuit 164. The high voltage charge command HVCHG is also conducted via conductor 149 to the control input of switch circuit 114, and switch circuit 114 closes in response to connect positive high voltage battery voltage EXT B+ to the positive power input of high voltage charge circuit 164. Switch circuit 114 may be, for example, a field effect transistor (FET) with its source-to-drain path interrupting the EXT B+ conductor 118 and its gate receiving the HVCHG signal on conductor 145. High voltage charge circuit 164 is thereby rendered ready to begin charging the high voltage output capacitors 156, 158, 160, and 162 with charging current from high voltage battery 112.

[0044] High voltage output capacitors 156, 158, 160, and 162 may be charged to very high voltages, e.g., 300-1000V, to be discharged through the body and heart between the electrode pair of subcutaneous cardioversion-defibrillation electrodes 113 and 123. The details of the voltage charging circuitry are also not deemed to be critical with regard to practicing the present invention; one high voltage charging circuit believed to be suitable for the purposes of the present invention is disclosed. High voltage capacitors 156, 158, 160 and 162 may be charged, for example, by high voltage

charge circuit 164 and a high frequency, high-voltage transformer 168 as described in detail in commonly assigned U.S. Pat. No. 4,548,209 "Energy Converter for Implantable Cardioverter" to Wielders, et al. Proper charging polarities are maintained by diodes 170, 172, 174 and 176 interconnecting the output windings of high-voltage transformer 168 and the capacitors 156, 158, 160, and 162. As noted above, the state of capacitor charge is monitored by circuitry within the high voltage output circuit 140 that provides a VCAP, feedback signal indicative of the voltage to the timing and control circuit 144. Timing and control circuit 144 terminates the high voltage charge command HVCHG when the VCAP signal matches the programmed capacitor output voltage, i.e., the cardioversion-defibrillation peak shock voltage.

[0045] Control circuit 144 then develops first and second control signals NPULSE 1 and NPULSE 2, respectively, that are applied to the high voltage output circuit 140 for triggering the delivery of cardioverting or defibrillating shocks. In particular, the NPULSE 1 signal triggers discharge of the first capacitor bank, comprising capacitors 156 and 158. The NPULSE 2 signal triggers discharge of the first capacitor bank and a second capacitor bank, comprising capacitors 160 and 162. It is possible to select between a plurality of output pulse regimes simply by modifying the number and time order of assertion of the NPULSE 1 and NPULSE 2 signals. The NPULSE 1 signals and NPULSE 2 signals may be provided sequentially, simultaneously or individually. In this way, control circuitry 144 serves to control operation of the high voltage output stage 140, which delivers high energy cardioversion-defibrillation shocks between the pair of the cardioversion-defibrillation electrodes 18 and 25 coupled to the HV-1 and COMMON output as shown in FIG. 2.

[0046] Thus, subcutaneous device 14 monitors the patient's cardiac status and initiates the delivery of a cardioversion-defibrillation shock through the cardioversion-defibrillation electrodes 18 and 25 in response to detection of a tachyarrhythmia requiring cardioversion-defibrillation. The high HVCHG signal causes the high voltage battery 112 to be connected through the switch circuit 114 with the high voltage charge circuit 164 and the charging of output capacitors 156, 158, 160, and 162 to commence. Charging continues until the programmed charge voltage is reflected by the VCAP signal, at which point control and timing circuit 144 sets the HVCHG signal low terminating charging and opening switch circuit 114. The subcutaneous device 14 can be programmed to attempt to deliver cardioversion shocks to the heart in the manners described above in timed synchrony with a detected R-wave or can be programmed or fabricated to deliver defibrillation shocks to the heart in the manners described above without attempting to synchronize the delivery to a detected R-wave. Episode data related to the detection of the tachyarrhythmia and delivery of the cardioversion-defibrillation shock can be stored in RAM for uplink telemetry transmission to an external programmer as is well known in the art to facilitate in diagnosis of the patient's cardiac state. A patient receiving the device 14 on a prophylactic basis would be instructed to report each such episode to the attending physician for further evaluation of the patient's condition and assessment for the need for implantation of a more sophisticated ICD.

[0047] Subcutaneous device 14 desirably includes telemetry circuit (not shown in FIG. 2), so that it is capable of being programmed by means of external programmer 20 via

a 2-way telemetry link (not shown). Uplink telemetry allows device status and diagnostic/event data to be sent to external programmer 20 for review by the patient's physician. Downlink telemetry allows the external programmer via physician control to allow the programming of device function and the optimization of the detection and therapy for a specific patient. Programmers and telemetry systems suitable for use in the practice of the present invention have been well known for many years. Known programmers typically communicate with an implanted device via a bi-directional radio-frequency telemetry link, so that the programmer can transmit control commands and operational parameter values to be received by the implanted device, so that the implanted device can communicate diagnostic and operational data to the programmer. Programmers believed to be suitable for the purposes of practicing the present invention include the Models 9790 and CareLink® programmers, commercially available from Medtronic, Inc., Minneapolis, Minn.

[0048] Various telemetry systems for providing the necessary communications channels between an external programming unit and an implanted device have been developed and are well known in the art. Telemetry systems believed to be suitable for the purposes of practicing the present invention are disclosed, for example, in the following U.S. Patents: U.S. Pat. No. 5,127,404 to Wyborny et al. entitled "Telemetry Format for Implanted Medical Device"; U.S. Pat. No. 4,374,382 to Markowitz entitled "Marker Channel Telemetry System for a Medical Device"; and U.S. Pat. No. 4,556,063 to Thompson et al. entitled "Telemetry System for a Medical Device". The Wyborny et al. '404, Markowitz '382, and Thompson et al. '063 patents are commonly assigned to the assignee of the present invention, and are each hereby incorporated by reference herein in their respective entireties.

[0049] According to an embodiment of the present invention, in order to automatically select the preferred ECG vector set, it is necessary to have an index of merit upon which to rate the quality of the signal. "Quality" is defined as the signal's ability to provide accurate heart rate estimation and accurate morphological waveform separation between the patient's usual sinus rhythm and the patient's ventricular tachyarrhythmia.

[0050] Appropriate indices may include R-wave amplitude, R-wave peak amplitude to waveform amplitude between R-waves (i.e., signal to noise ratio), low slope content, relative high versus low frequency power, mean frequency estimation, probability density function, or some combination of these metrics.

[0051] Automatic vector selection might be done at implantation or periodically (daily, weekly, monthly) or both. At implant, automatic vector selection may be initiated as part of an automatic device turn-on procedure that performs such activities as measure lead impedances and battery voltages. The device turn-on procedure may be initiated by the implanting physician (e.g., by pressing a programmer button) or, alternatively, may be initiated automatically upon automatic detection of device/lead implantation. The turn-on procedure may also use the automatic vector selection criteria to determine if ECG vector quality is adequate for the current patient and for the device and lead position, prior to suturing the subcutaneous device 14 device in place and closing the incision. Such an ECG quality indicator would allow the implanting physician to maneuver the device to a

new location or orientation to improve the quality of the ECG signals as required. The preferred ECG vector or vectors may also be selected at implant as part of the device turn-on procedure. The preferred vectors might be those vectors with the indices that maximize rate estimation and detection accuracy. There may also be an a priori set of vectors that are preferred by the physician, and as long as those vectors exceed some minimum threshold, or are only slightly worse than some other more desirable vectors, the a priori preferred vectors are chosen. Certain vectors may be considered nearly identical such that they are not tested unless the a priori selected vector index falls below some predetermined threshold.

[0052] Depending upon metric power consumption and power requirements of the device, the ECG signal quality metric may be measured on the range of vectors (or alternatively, a subset) as often as desired. Data may be gathered, for example, on a minute, hourly, daily, weekly or monthly basis. More frequent measurements (e.g., every minute) may be averaged over time and used to select vectors based upon susceptibility of vectors to occasional noise, motion noise, or EMI, for example.

[0053] Alternatively, the subcutaneous device **14** may have an indicator/sensor of patient activity (piezo-resistive, accelerometer, impedance, or the like) and delay automatic vector measurement during periods of moderate or high patient activity to periods of minimal to no activity. One representative scenario may include testing/evaluating ECG vectors once daily or weekly while the patient has been determined to be asleep (using an internal clock (e.g., 2:00 am) or, alternatively, infer sleep by determining the patient's position (via a 2- or 3-axis accelerometer) and a lack of activity).

[0054] If infrequent automatic, periodic measurements are made, it may also be desirable to measure noise (e.g., muscle, motion, EMI, etc.) in the signal and postpone the vector selection measurement when the noise has subsided.

[0055] Subcutaneous device **14** may optionally have an indicator of the patient's posture (via a 2- or 3-axis accelerometer). This sensor may be used to ensure that the differences in ECG quality are not simply a result of changing posture/position. The sensor may be used to gather data in a number of postures so that ECG quality may be averaged over these postures or, alternatively, selected for a preferred posture.

[0056] In the preferred embodiment, vector quality metric calculations would occur a number of times over approximately 1 minute, once per day, for each vector. These values would be averaged for each vector over the course of one week. Averaging may consist of a moving average or recursive average depending on time weighting and memory considerations. In this example, the preferred vector(s) would be selected once per week.

[0057] FIG. 3 is a state diagram of detection of arrhythmias in a medical device according to an embodiment of the present invention. As illustrated in FIG. 3, during normal operation, the device **14** is in a not concerned state **302**, during which R-wave intervals are being evaluated to identify periods of rapid rates and/or the presence of asystole. Upon detection of short R-wave intervals simultaneously in two separate ECG sensing vectors, indicative of an event that, if confirmed, may require the delivery of therapy, the device **14** transitions from the not concerned state **302** to a concerned state **304**. In the concerned state **304** the device

14 evaluates a predetermined window of ECG signals to determine the likelihood that the signal is corrupted with noise and to discriminate rhythms requiring shock therapy from those that do not require shock therapy, using a combination of R-wave intervals and ECG signal morphology information.

[0058] If a rhythm requiring shock therapy continues to be detected while in the concerned state **304**, the device **14** transitions from the concerned state **304** to an armed state **306**. If a rhythm requiring shock therapy is no longer detected while the device is in the concerned state **304** and the R-wave intervals are determined to no longer be short, the device **14** returns to the not concerned state **302**. However, if a rhythm requiring shock therapy is no longer detected while the device is in the concerned state **304**, but the R-wave intervals continue to be detected as being short, processing continues in the concerned state **304**.

[0059] In the armed state **306**, the device **14** charges the high voltage shocking capacitors and continues to monitor R-wave intervals and ECG signal morphology for spontaneous termination. If spontaneous termination of the rhythm requiring shock therapy occurs, the device **14** returns to the not concerned state **302**. If the rhythm requiring shock therapy is still determined to be occurring once the charging of the capacitors is completed, the device **14** transitions from the armed state **306** to a shock state **308**. In the shock state **308**, the device **14** delivers a shock and returns to the armed state **306** to evaluate the success of the therapy delivered.

[0060] The transitioning between the not concerned state **302**, the concerned state **304**, the armed state **306** and the shock state **308** may be performed as described in detail in U.S. Pat. No. 7,894,894 to Stadler et al., incorporated herein by reference in its entirety.

[0061] FIG. 4 is a flowchart of a method for detecting arrhythmias in a subcutaneous device according to an embodiment of the present disclosure. As illustrated in FIG. 4, device **14** continuously evaluates the two channels ECG1 and ECG2 associated with two predetermined electrode vectors to determine when sensed events occur. For example, the electrode vectors for the two channels ECG1 and ECG2 may include a first vector (ECG1) selected between electrode **20** positioned on lead **16** and the housing or can **25** of ICD **14**, while the other electrode vector (ECG 2) is a vertical electrode vector between electrode **20** and electrode **22** positioned along the lead **16**. However, the two sensing channels may in any combination of possible vectors, including those formed by the electrodes shown in FIG. 2, or other additional electrodes (not shown) that may be included along the lead or positioned along the housing of ICD **14**.

[0062] According to an embodiment of the present application, for example, the device **14** determines whether to transition from the not concerned state **302** to the concerned state **304** by determining a heart rate estimate in response to the sensing of R-waves, as described in U.S. Pat. No. 7,894,894 to Stadler et al., incorporated herein by reference in its entirety.

[0063] Upon transition from the not concerned state to the concerned state, Block **305**, a most recent window of ECG data from both channels ECG1 and ECG2 are utilized, such as three seconds, for example, so that processing is triggered in the concerned state **304** by a three-second timeout, rather than by the sensing of an R-wave, which is utilized when in the not concerned state **302**. It is understood that while the

processing is described as being triggered over a three second period, other times periods for the processing time utilized when in the concerned state 304 may be chosen, but should preferably be within a range of 0.5 to 10 seconds. As a result, although sensing of individual R-waves continues to occur in both channels ECG1 and ECG2 when in the concerned state 304, and the buffer of 12 R-R intervals continues to be updated, the opportunities for changing from the concerned state 304 to another state and the estimates of heart rate only occur once the three-second timer expires. Upon initial entry to the concerned state 304, it is advantageous to process the most recent three-seconds of ECG data, i.e., ECG data for the three seconds leading up to the transition to the concerned state 304. This requires a continuous circular buffering of the most recent three seconds of ECG data even while in the not concerned state 302.

[0064] While in the concerned state 304, the present invention determines how sinusoidal and how noisy the signals are in order to determine the likelihood that a ventricular fibrillation (VF) or fast ventricular tachycardia (VT) event is taking place, since the more sinusoidal and low noise the signal is, the more likely a VT/VF event is taking place. As illustrated in FIG. 4, once the device transitions from the not concerned state 302 to the concerned state 304, Block 305, a buffer for each of the two channels ECG 1 and ECG2 for storing classifications of 3-second segments of data as “shockable” or “non-shockable” is cleared. Processing of signals of the two channels ECG1 and ECG2 while in the concerned state 304 is then triggered by the three second time period, rather than by the sensing of an R-wave utilized during the not concerned state 302.

[0065] Once the three second time interval has expired, YES in Block 341, morphology characteristics of the signal during the three second time interval for each channel are utilized to determine whether the signals are likely corrupted by noise artifacts and to characterize the morphology of the signal as “shockable” or “not shockable”. For example, using the signals associated with the three second time interval, a determination is made for each channel ECG1 and ECG 2 as to whether the channel is likely corrupted by noise, Block 342, and a determination is then made as to whether both channels ECG1 and ECG2 are corrupted by noise, Block 344.

[0066] FIG. 5 is a flowchart of a method of determining noise according to an embodiment of the present disclosure. As illustrated in FIG. 5, the determination as to whether the signal associated with each of the channels ECG1 and ECG2 is likely corrupted by noise, Block 342 of FIG. 4, includes multiple sequential noise tests that are performed on each channel ECG and ECG2. During a first noise test, for example, a determination is made as to whether a metric of signal energy content of the signal for the channel is within predetermined limits, Block 380. For example, the amplitude of each sample associated with the three second window is determined, resulting in N sample amplitudes, from which a mean rectified amplitude is calculated as the ratio of the sum of the rectified sample amplitudes to the total number of sample amplitudes N for the segment. If the sampling rate is 256 samples per second, for example, the total number of sample amplitudes N for the three-second segment would be N=768 samples.

[0067] Once the mean rectified amplitude is calculated, a determination is made as to whether the mean rectified amplitude is between an upper average amplitude limit and

a lower average amplitude limit, the lower average amplitude limit being associated with asystole episodes without artifact and the upper average amplitude limit being associated with a value greater than what would be associated with ventricular tachycardia and ventricular fibrillation events. According to an embodiment of the present invention, the upper average amplitude limit is set as 1.5 mV, and the lower average amplitude limit is set as 0.013 mV. While the metric of signal energy content is described above as the mean rectified amplitude, it is understood that other signal of energy contents could be utilized.

[0068] If the determined mean rectified amplitude is not between the upper average amplitude limit and the lower average amplitude limit, the three second segment for that channel is identified as being likely corrupted with noise, Block 386, and no further noise tests are initiated for that channel's segment.

[0069] If the determined mean rectified amplitude is located between the upper average amplitude limit and the lower average amplitude limit, a noise to signal ratio is calculated and a determination is made as to whether the noise to signal ratio is less than a predetermined noise to signal threshold, Block 382. For example, the amplitude of each sample associated with the three second window is determined, resulting in N raw sample amplitudes. The raw signal is lowpass filtered, resulting in L lowpass sample amplitudes. The raw mean rectified amplitude is determined as the average of the absolute values of the raw sample amplitudes. The lowpass mean rectified amplitude is determined as the average of the absolute values of the lowpass sample amplitudes. Next, a highpass mean rectified amplitude is then calculated as the difference between the raw mean rectified amplitude and the lowpass mean rectified amplitude. The noise to signal ratio is then determined as the ratio of the highpass mean rectified amplitude to the lowpass mean rectified amplitude. If the noise to signal ratio is greater than a predetermined threshold, such as 0.0703, for example, the three second segment for that channel is identified as being likely corrupted with noise, Block 386, and no further noise tests are initiated for the segment.

[0070] If the noise to signal ratio is less than or equal to the predetermined threshold, a determination is made as to whether the signal is corrupted by muscle noise, Block 384. According to an embodiment of the present invention, the determination as to whether the signal is corrupted by muscle noise is made by determining whether the signal includes a predetermined number of signal inflections indicative of the likelihood of the signal being corrupted by muscle noise, using a muscle noise pulse count that is calculated to quantify the number of signal inflections in the three second interval for each channel ECG1 and ECG2. The presence of a significant number of inflections is likely indicative of muscle noise.

[0071] FIG. 6A is a graphical representation of a determination of whether a signal is corrupted by muscle noise according to an embodiment of the present invention. FIG. 6B is a flowchart of a method of determining whether a signal is corrupted by muscle noise according to an embodiment of the present invention. For example, as illustrated in FIGS. 6A and 6B, in order to determine a muscle noise count for the three second interval, the raw signal 420 is applied to a first order derivative filter to obtain a derivative signal 422, and all of the zero-crossings 424 in the derivative signal 422 are located, Block 460. A data pair corresponding to the

data points immediately prior to and subsequent to the zero crossings 424, points 426 and 428 respectively, for each crossing is obtained. The value of the data point in each data pair with smaller absolute value is zeroed in order to allow a clear demarcation of each pulse when a rectified signal 430 is derived from the derivative signal 422 with zeroed zero-crossing points 432.

[0072] A pulse amplitude threshold T_d , for determining whether the identified inflection is of a significant amplitude to be identified as being associated with muscle noise, is determined, Block 462, by dividing the rectified signal from the three second segment into equal sub-segments 434, estimating a local maximum amplitude 436-442 for each of the sub-segments 434, and determining whether the local amplitudes 436-442 are less than a portion of the maximum amplitude, which is maximum amplitude 440 in the example of FIG. 6A, for the whole three second segment. If the local maximum amplitude is less than the portion of the maximum amplitude for the whole three second segment, the local maximum amplitude is replaced by the maximum for the whole three second segment for the sub-segment corresponding to that local maximum amplitude.

[0073] It is understood that while only two or less zero-crossing points are shown as being located within the sub-segments in the illustration of FIG. 6A for the sake of simplicity, in fact each of the sub-segments 434, which have a length of approximately 750 milliseconds, will contain many inflections, such as every 25 milliseconds, for example.

[0074] According to an embodiment of the present invention, the three second segment is divided into four sub-segments and the local maximum amplitudes are replaced by the maximum amplitude for the whole segment if the local maximum amplitude is less than one fifth of the maximum amplitude for the whole segment. Once the determination of whether to replace the local maximum amplitudes for each of the sub-segments with the maximum amplitude for the whole segment is completed, the pulse amplitude threshold T_d for the segment is set equal to a predetermined fraction of the mean of the local maximum amplitudes for each of the sub-segments. According to an embodiment of the present invention, the pulse amplitude threshold T_d for the three second segment is set equal to one sixth of the mean of the local maximum amplitudes 436-440.

[0075] Once the pulse amplitude threshold T_d has been determined, the inflections associated with the signal for the three second segment is classified as being of significant level to be likely indicative of noise by determining whether the pulse amplitude threshold T_d is less than a pulse threshold, Block 464. According to an embodiment of the present invention, the pulse threshold is set as 1 microvolt. If the pulse amplitude threshold T_d is less than the pulse threshold, the signal strength is too small for a determination of muscle noise, and therefore the signal is determined to be not likely corrupted by noise and therefore the channel is determined to be not noise corrupted, Block 466.

[0076] If the pulse amplitude threshold T_d is greater than or equal to the pulse threshold, the three second segment is divided into twelve sub-segments of 250 ms window length, the number of muscle noise pulses in each sub-segment is counted, and both the sub-segment having the maximum number of muscle noise pulses and the number of sub-segments having 6 or more muscle noise pulses that are greater than a predetermined minimum threshold is deter-

mined. Muscle noise is determined to be present in the signal if either the maximum number of muscle noise pulses in a single sub-segment is greater than a noise pulse number threshold or the number of sub-segments of the twelve sub-segments having 6 or more muscle noise pulses greater than the minimum threshold is greater than or equal to a sub-segment pulse count threshold. According to an embodiment of the present invention, the noise pulse number threshold is set equal to eight and the sub-segment pulse count threshold is set equal to three.

[0077] For example, if the pulse amplitude threshold T_d is greater than or equal to the pulse threshold, No in Block 464, the maximum number of muscle noise counts in a single sub-segment is determined, Block 468. If the maximum number of muscle noise counts is greater than the noise pulse number threshold, Yes in Block 470, the channel is determined to be noise corrupted, Block 472. If the maximum number of muscle noise counts for the channel is less than or equal to the noise pulse number threshold, No in Block 470, the number of sub-segments of the twelve sub-segments having 6 or more muscle noise pulses greater than the minimum threshold is determined, Block 474, and if the number is greater than or equal to a sub-segment pulse count threshold, Yes in Block 476, the channel is determined to be noise corrupted, Block 472. If the number is less than the sub-segment pulse count threshold, No in Block 476, the channel is determined not to be noise corrupted, Block 466.

[0078] FIG. 6C is a flowchart of a method of determining whether a signal is corrupted by muscle noise according to an embodiment of the present invention. Since muscle noise can be present during an episode of ventricular tachycardia, the width of the overall signal pulse waveform is determined in order to distinguish between signals that are determined likely to be purely noise related and signals that are both shockable events and determined to include noise. Therefore, as illustrated in FIG. 6C, according to an embodiment of the present invention, once muscle noise is determined to be present as a result of the muscle noise pulse count being satisfied, No in Block 470 and Yes in Block 476, a determination is made as to whether the signal is both noise corrupted and shockable, Block 480.

[0079] According to an embodiment of the present invention, the determination in Block 480 as to whether the signal is both noisy and shockable is made, for example, by dividing the rectified signal, having 768 data points, into four sub-segments and determining a maximum amplitude for each of the four sub-segments by determining whether a maximum amplitude for the sub-segment is less than a portion of the maximum amplitude for the entire rectified signal in the three second segment. For example, a determination is made for each sub-segment as to whether the maximum amplitude for the sub-segment is less than one fourth of the maximum amplitude for the entire rectified signal. If less than a portion of the maximum amplitude for the entire rectified signal in the three second segment, the maximum amplitude for the sub-segment is set equal to the maximum amplitude for the entire rectified signal.

[0080] A mean rectified amplitude for each of the sub-segments is determined by dividing the sum of the rectified amplitudes for the sub-segment by the number of samples in the sub-segment, i.e., $768 \div 4$. Then the normalized mean rectified amplitude for each sub-segment is determined by dividing the mean rectified amplitude for each of the sub-segments by the peak amplitude for the sub-segment. The

normalized mean rectified amplitude for the three second segment is then determined as the sum of the normalized mean rectified amplitudes for each sub-segment divided by the number of sub-segments, i.e., four.

[0081] Therefore, once muscle noise is suspected as a result of the determination of the muscle noise pulse count, the determination of Block 480 based on whether the normalized mean rectified amplitude for the three second segment is greater than a predetermined threshold for identifying signals that, despite being indicative of a likelihood of being associated with noise, nevertheless are associated with a shockable event. For example, according to an embodiment of the present invention, a determination is made as to whether the normalized mean rectified amplitude for the three second segment is greater than 18 microvolts. If the normalized mean rectified amplitude for the three second segment is less than or equal to the predetermined threshold, the channel is likely corrupted by muscle noise and not shockable, No in Block 480, and is therefore identified as being corrupted by noise, Block 472. If the normalized mean rectified amplitude for the three second segment is greater than the predetermined threshold, the channel is determined to be likely corrupted by muscle noise and shockable, Yes in Block 480, and is therefore identified as not to be likely corrupted by muscle noise, Block 478.

[0082] Returning to FIG. 5, when the signal is determined to be not likely corrupted by muscle noise, a determination is made as to whether the mean frequency of the signal associated with the channel is less than a predetermined mean frequency threshold, Block 388, such as 11 Hz for example. The mean frequency of the signal during the 3 second segment for each channel ECG 1 and ECG2 is generated, for example, by calculating the ratio of the mean absolute amplitude of the first derivative of the 3 second segment to the mean absolute amplitude of the 3 second segment, multiplied by a constant scaling factor. If the mean frequency is determined to be greater than or equal to the predetermined mean frequency threshold, No in Block 388, the three second segment for that channel is identified as being likely corrupted with noise, Block 386. If the mean frequency is determined to be less than the predetermined mean frequency threshold, Yes in Block 388, the three second segment for that channel is identified as being not noise corrupted, Block 390.

[0083] According to an embodiment of the present invention, since the mean spectral frequency tends to be low for true ventricular fibrillation events, moderate for organized rhythms such as sinus rhythm and supraventricular tachycardia, for example, and high during asystole and noise, the determination in Block 388 includes determining whether the mean frequency is less than a predetermined upper mean frequency threshold, such as 11 Hz (i.e., mean period T of approximately 91 milliseconds) for example, and whether the mean frequency is less than a predetermined lower mean frequency, such as 3 Hz for example. If the mean frequency is below a second, lower threshold, such as 3 Hz, for example, the signal is also rejected as noise and no further noise tests are initiated. This comparison of the mean frequency to a second lower threshold is intended to identify instances of oversensing, resulting in appropriate transition to the concerned state. If the mean frequency of the signal is less than 3 Hz, it is generally not possible for the heart rate to be greater than 180 beats per minute. In practice, it may

be advantageous to set the lower frequency threshold equal to the programmed VT/VF detection rate, which is typically approximately 3 Hz.

[0084] Therefore, in the determination of Block 388, if the mean frequency is determined to be either greater than or equal to the predetermined upper mean frequency threshold or less than the lower threshold, the three second segment for that channel is identified as being likely corrupted with noise, Block 386. If the mean frequency is determined to be both less than the predetermined upper mean frequency threshold and greater than the lower threshold, the three second segment for that channel is identified as not being noise corrupted, Block 390.

[0085] Returning to FIG. 4, once the determination as to whether the channels ECG1 and ECG2 are corrupted by noise is made, Block 342, a determination is made as to whether both channels are determined to be noise corrupted, Block 344. If the signal associated with both channels ECG1 and ECG2 is determined to likely be corrupted by noise, both channels are classified as being not shockable, Block 347, and therefore a buffer for each channel ECG1 and ECG 2 containing the last three classifications of the channel is updated accordingly and the process is repeated for the next three-second windows. If both channels ECG1 and ECG2 are not determined to be likely corrupted by noise, No in Block 344, the device distinguishes between either one of the channels being not corrupted by noise or both channels being not corrupted by noise by determining whether noise was determined to be likely in only one of the two channels ECG1 and ECG2, Block 346.

[0086] If noise was likely in only one of the two channels, a determination is made whether the signal for the channel not corrupted by noise, i.e., the clean channel, is more likely associated with a VT event or with a VF event by determining, for example, whether the signal for that channel includes R-R intervals that are regular and the channel can be therefore classified as being relatively stable, Block 348. If the R-R intervals are determined not to be relatively stable, NO in Block 348, the signal for that channel is identified as likely being associated with VF, which is then verified by determining whether the signal is in a VF shock zone, Block 350, described below. If R-R intervals for that channel are determined to be stable, YES in Block 348, the signal is identified as likely being associated with VT, which is then verified by determining whether the signal is in a VT shock zone, Block 352, described below.

[0087] If noise was not likely for both of the channels, No in Block 346, i.e., both channels are determined to be clean channels, a determination is made whether the signal for both channels is more likely associated with a VT event or with a VF event by determining whether the signal for both channels includes R-R intervals that are regular and can be therefore classified as being relatively stable, Block 356. The determination in Block 356 of whether the R-R intervals are determined to be relatively stable may be made using the method described in U.S. Pat. No. 7,894,894 to Stadler et al., incorporated herein by reference in its entirety. If the R-R intervals are determined not to be relatively stable, NO in Block 356, the signal for both channels is identified as likely being associated with VF, which is then verified by determining whether the signal for each channel is in a VF shock zone, Block 360, described below. If R-R intervals for both channels are determined to be stable, YES in Block 356, the signal is identified as likely being associated with VT, which

is then verified by determining, based on both channels, whether the signal is in a VT shock zone, Block 358.

[0088] FIG. 7 is a graphical representation of a VF shock zone according to an embodiment of the present invention. As illustrated in FIG. 7, a VF shock zone 500 is defined for each channel ECG1 and ECG2 based on the relationship between the calculated low slope content and the spectral width associated with the channel. For example, the shock zone is defined by a first boundary 502 associated with the low slope content set for by the equation:

$$\text{Low slope content} = -0.0013 \times \text{spectral width} + 0.415 \quad \text{Equation 1}$$

and a second boundary 504 associated with the spectral width set forth by the equation:

$$\text{spectral width} = 200 \quad \text{Equation 2}$$

[0089] The low slope content metric is calculated as the ratio of the number of data points with low slope to the total number of samples in the 3-second segment. For example, according to an embodiment of the present invention, the difference between successive ECG samples is determined as an approximation of the first derivative (i.e., the slope) of the ECG signal. In particular, the raw signal for each channel is applied to a first order derivative filter to obtain a derivative signal for the three-second segment. The derivative signal is then rectified, divided into four equal sub-segments, and the largest absolute slope is estimated for each of the four sub-segments.

[0090] A determination is made as to whether the largest absolute slopes are less than a portion of the overall largest absolute slope for the whole three-second segment, such as one-fifth of the overall absolute slope, for example. If the largest absolute slope is less than the portion of the overall slope, then the slope value for that sub-segment is set equal to the overall largest absolute slope. If the largest absolute slope is not less than the portion of the overall slope, then the slope value for that sub-segment is set equal to the determined largest absolute slope for the sub-segment.

[0091] Once the slope value for each of the sub-segments has been determined and updated by being set equal to the largest slope for the three second segment, if necessary, the average of the four slopes is calculated and divided by a predetermined factor, such as 16 for example, to obtain a low slope threshold. The low slope content is then obtained by determining the number of sample points in the three-second segment having an absolute slope less than or equal to the low slope threshold.

[0092] According to an embodiment of the present invention, if, during the determination of the low slope threshold, the low slope threshold is a fraction, rather than a whole number, a correction is made to the low slope content to add a corresponding fraction of the samples. For example, if the threshold is determined to be 4.5, then the low slope content is the number of sample points having an absolute slope less than or equal to 4 plus one half of the number of sample points with slope equal to 5.

[0093] The spectral width metric, which corresponds to an estimate of the spectral width of the signal for the three-second segment associated with each channel ECG1 and ECG2, is defined, for example, as the difference between the mean frequency and the fundamental frequency of the signal. According to an embodiment of the present invention, the spectral width metric is calculated by determining the difference between the most recent estimate of the RR-cycle length and the mean spectral period of the signal

for that channel. As is known in the art, the mean spectral period is the inverse of the mean spectral frequency.

[0094] As can be seen in FIG. 7, since noise 506 tends to have a relatively higher spectral width, and normal sinus rhythm 508 tends to have a relatively higher low slope content relative to VF, both noise 506 and normal sinus rhythm 508 would be located outside the VF shock zone 500.

[0095] A determination is made for each channel ECG1 and ECG2 as to whether the low slope content for that channel is less than both the first boundary 502 and the spectral width is less than the second boundary 504, i.e., the low slope content is less than $-0.0013 \times \text{spectral width} + 0.415$, and the spectral width is less than 200. For example, once the event is determined to be associated with VF, i.e., the intervals for both channels are determined to be irregular, No in Block 356, a determination is made that channel ECG1 is in the VF shock zone, Yes in Block 360, if, for channel ECG1, both the low slope content is less than the first boundary 502 and the spectral width is less than the second boundary 504. The three second segment for that channel ECG1 is then determined to be shockable, Block 363 and the associated buffer for that channel is updated accordingly. If either the low slope content for the channel is not less than the first boundary 502 or the spectral width is not less than the second boundary, the channel ECG1 is determined not to be in the VF shock zone, No in Block 360, the three second segment for that channel ECG1 is then determined to be not shockable, Block 365, and the associated buffer is updated accordingly.

[0096] Similarly, a determination is made that channel ECG2 is in the VF shock zone, Yes in Block 362, if, for channel ECG2, both the low slope content is less than the first boundary 502 and the spectral width is less than the second boundary 504. The three second segment for that channel ECG2 is then determined to be shockable, Block 369 and the associated buffer for that channel is updated accordingly. If either the low slope content for the channel is not less than the first boundary 502 or the spectral width is not less than the second boundary, the channel ECG2 is determined not to be in the VF shock zone, No in Block 362, the three second segment for that channel ECG2 is then determined to be not shockable, Block 367, and the associated buffer is updated accordingly.

[0097] FIGS. 8A and 8B are graphical representations of the determination of whether an event is within a shock zone according to an embodiment of the present invention. During the determination of whether the event is within the VT shock zone, Block 358 of FIG. 4, the low slope content and the spectral width is determined for each channel ECG1 and ECG2, as described above in reference to determining the VF shock zone. A determination is made as to which channel of the two signal channels ECG1 and ECG2 contains the minimum low slope content and which channel of the two signal channels ECG 1 and ECG2 contains the minimum spectral width. A first VT shock zone 520 is defined based on the relationship between the low slope content associated with the channel determined to have the minimum low slope content and the spectral width associated with the channel determined to have the minimum spectral width. For example, according to an embodiment of the present invention, the first VT shock zone 520 is defined by a boundary 522 associated with the minimum low slope content and the minimum spectral width set forth by the equation:

$$LSC = -0.004 \times SW + 0.93$$

Equation 3

[0098] A second VT shock zone **524** is defined based on the relationship between the low slope content associated with the channel determined to have the minimum low slope content and the normalized mean rectified amplitude associated with the channel determined to have the maximum normalized mean rectified amplitude. In order to determine the normalized mean rectified amplitudes for the two channels ECG1 and ECG2 utilized during the VT shock zone test, the amplitude of each sample associated with the three second window is determined, resulting in N sample amplitudes, from which a mean rectified amplitude is calculated as the ratio of the sum of the rectified sample amplitudes to the total number of sample amplitudes N for the segment. If the sampling rate is 256 samples per second, for example, the total number of sample amplitudes N for the three-second segment would be N=768 samples.

[0099] According to an embodiment of the present invention, for example, the second VT shock zone **524** is defined by a second boundary **526** associated with the relationship between the minimum low slope count and the maximum normalized mean rectified amplitude set forth by the equation:

$$NMRA = 68 \times LSC + 8.16$$

Equation 4

[0100] If both the minimum low slope count is less than the first boundary **522**, i.e., $-0.004 \times \text{minimum spectral width} + 0.93$, and the maximum normalized mean rectified amplitude is greater than the second boundary **526**, i.e., $68 \times \text{minimum low slope count} + 8.16$, the event is determined to be in the VT shock zone, YES in Block **358**, and both channels ECG1 and ECG2 are determined to be shockable, Block **357**, and the associated buffers are updated accordingly. If either the minimum low slope count is not less than the first boundary **522** or the maximum normalized mean rectified amplitude is not greater than the second boundary **526**, the event is determined to be outside the VT shock zone, NO in Block **358**, and both channels ECG1 and ECG2 are determined to be not shockable, Block **359**.

[0101] As described, during both the VF shock zone test, Blocks **360** and **362**, and the VT shock zone test, Block **358**, the test results for each channel ECG1 and ECG2 as being classified as shockable or not shockable are stored in a rolling buffer containing the most recent eight such designations, for example, for each of the two channels ECG1 and ECG2 that is utilized in the determination of Block **356**, as described below.

[0102] If only one of the two channels ECG1 and ECG2 is determined to be corrupted by noise, YES in Block **346**, a determination is made whether the signal for the channel not corrupted by noise, i.e., the “clean channel”, is more likely associated with a VT event or with a VF event by determining whether the signal for the clean channel includes R-R intervals that are regular and can be therefore classified as being relatively stable, Block **348**. If the R-R intervals are determined not to be relatively stable, NO in Block **348**, the signal for the clean channel is identified as likely being associated with VF, which is then verified by determining whether the signal for the clean channel is in a VF shock zone, Block **350**, described below. If R-R intervals for the clean channel are determined to be stable, YES in Block **348**, the signal is identified as likely being associated with VT, which is then verified by determining whether the signal for the clean channel is in a VT shock zone, Block **352**.

[0103] According to an embodiment of the present invention, in order to determine whether the signal for the clean channel includes R-R intervals that are regular and the clean channel can be therefore classified as being either relatively stable, Yes in Block **348**, or relatively unstable, No in Block **348**, the device discriminates VT events from VF events in Block **348** by determining whether the relative level of variation in the RR-intervals associated with the clean channel is regular. FIG. **9** is a flowchart of a method for discriminating cardiac events according to an embodiment of the disclosure. For example, as illustrated in FIG. **9**, predetermined maximum and minimum intervals for the clean channel are identified from the updated buffer of 12 RR-intervals, Block **342** of FIG. **4**. According to an embodiment of the present invention, the largest RR-interval and the sixth largest RR-interval of the twelve RR-intervals are utilized as the maximum interval and the minimum interval, respectively.

[0104] The difference between the maximum RR-interval and the minimum RR-interval of the 12 RR-intervals is calculated to generate an interval difference associated with the clean channel, **702**. A determination is then made as to whether the interval difference is greater than a predetermined stability threshold, Block **704**, such as 110 milliseconds, for example.

[0105] If the interval difference is greater than the stability threshold, the event is classified as an unstable event, Block **706**, and therefore the clean channel is determined not to include regular intervals, No in Block **348**, and a determination is made as to whether the signal associated with the clean channel is within a predetermined VF shock zone, Block **350** of FIG. **4**, described below. If the interval difference is less than or equal to the stability threshold, No in Block **704**, the device determines whether the minimum RR interval is greater than a minimum interval threshold, Block **710**, such as 200 milliseconds, for example.

[0106] If the minimum interval is less than or equal to the minimum interval threshold, No in Block **710**, the event is classified as an unstable event, Block **706**, and therefore the clean channel is determined not to include regular intervals, No in Block **348**, and a determination is made as to whether the signal associated with the clean channel is within a predetermined VF shock zone, Block **350** of FIG. **4**, described below. If the minimum interval is greater than the minimum interval threshold, Yes in Block **710**, the device determines whether the maximum interval is less than or equal to a maximum interval threshold, Block **712**, such as 333 milliseconds for example. If the maximum interval is greater than the maximum interval threshold, the event is classified as an unstable event, Block **706**, and therefore the clean channel is determined not to include regular intervals, No in Block **348**, and a determination is made as to whether the signal associated with the clean channel is within a predetermined VF shock zone, Block **350** of FIG. **4**, described below. If the maximum interval is less than or equal to the maximum interval threshold, the event is classified as a stable event, Block **714**, and therefore the clean channel is determined to include regular intervals, Yes in Block **348**, and a determination is made as to whether the signal associated with the clean channel is within a predetermined VT shock zone, Block **352** of FIG. **4**, described below.

[0107] Returning to FIG. **4**, the determination of whether the clean channel is within the VF shock zone, Block **350**,

is made based upon a low slope content metric and a spectral width metric, similar to the VF shock zone determination described above in reference to Blocks 360 and 362, both of which are determined for the clean channel using the method described above. Once the low slope content metric and a spectral width metric are determined for the clean channel, the determination of whether the clean channel is in the VF shock zone is made using Equations 1 and 2, so that if either the low slope content for the clean channel is not less than the first boundary 502 or the spectral width is not less than the second boundary 504, the clean channel is determined not to be in the VF zone, No in Block 350 and both channels are classified as not shockable, Block 351, and the associated buffers are updated accordingly.

[0108] If the low slope content for the clean channel is less than the first boundary 502 and the spectral width is less than the second boundary 504, the clean channel is determined to be in the VF zone, Yes in Block 350. A determination is then made as to whether the channel determined to be corrupted by noise, i.e., the “noisy channel”, is within the VF shock zone, Block 354. If either the low slope content for the noisy channel is not less than the first boundary 502 or the spectral width is not less than the second boundary 504, the noisy channel is determined not to be in the VF zone, No in Block 354, the clean channel is classified as shockable and the noisy channel is classified as not shockable, Block 355, and the associated buffers are updated accordingly.

[0109] If the low slope content for the noisy channel is less than the first boundary 502 and the spectral width is less than the second boundary 504, the noisy channel is determined to be in the VF zone, Yes in Block 354, both the clean channel and the noisy channel are classified as being shockable, Block 353, and the associated buffers are updated accordingly.

[0110] Similar to the VT shock zone determination described above in reference to Block 358, during the determination as to whether the clean channel is within the VT shock zone in Block 352, the low slope content and the spectral width is determined for the clean channel as described above in reference to determining the VF shock zone. The first VT shock zone 520 is defined based on the relationship between the low slope content and the spectral width associated with the clean channel according to Equation 3, for example, and the second VT shock zone 524 is defined based on the relationship between the low slope count and the normalized mean rectified amplitude associated with the clean channel. The normalized mean rectified amplitudes for the clean channel is the same as described above in reference to the noise detection tests of Block 344. For example, according to an embodiment of the present invention, the second VT shock zone 524 is defined by a second boundary 526 associated with the relationship between the low slope count and the normalized mean rectified amplitude of the clean channel using Equation 4.

[0111] If both the low slope count is less than the first boundary 522, i.e., $-0.004 \times \text{spectral width of clean channel} + 0.93$, and the normalized mean rectified amplitude is greater than the second boundary 526, i.e., $68 \times \text{low slope count of clean channel} + 8.16$, the clean channel is determined to be in the VT shock zone, Yes in Block 352, both channels are classified as being shockable, Block 353, and the associated buffers are updated accordingly.

[0112] If either the low slope count is not less than the first boundary 522 or the maximum normalized mean rectified

amplitude is not greater than the second boundary 526, the clean channel is determined to be outside the VT shock zone, No in Block 352, both channels are classified as being not shockable, Block 351, and the associated buffers are updated accordingly.

[0113] According to an embodiment of the present disclosure, in addition to the classification of the sensing channels ECG1 and ECG2 as being shockable or not shockable using a gross morphology analysis, as described in FIG. 4, for example, the device also performs a beat-based analysis of the beats within each of the three-second windows, Block 368, so that the decision on state transitions (e.g. as to whether to transition from the concerned operating state 304 to the armed operating state 306 in Block 370, or from the armed state 306 to the shock state 308) is made based on the results of both an analysis of the gross morphology of the signal in the three-second window or windows for each sensing channel ECG1 and ECG2, and an analysis of the morphology of individual beats or R-waves in the three-second window or windows for each sensing channel ECG1 and ECG2, as described below. For a three-second segment to be classified as shockable, both the gross morphology and beat-based analysis have to classify the same three-second segment as shockable.

[0114] For example, according to an embodiment of the present invention, in order to determine whether to transition from the concerned operating state 304 to the armed operating state 306, the device determines whether a predetermined number, such as two out of three for example, of three-second segments for both channels ECG1 and ECG2 have been classified as being shockable during the gross morphology analysis, Blocks 353, 357, 363 and 369, and determines whether those three-second segments for both channels have also been classified as being shockable during the beat-based analysis, Block 368. If the predetermined number of three-second segments in both channels ECG1 and ECG2 have been classified as shockable during both the gross morphology analysis and the beat-based analysis, the device transitions from the concerned state 304 to the armed state 306, Yes in Block 370. When the device determines to transition from the concerned state 304 to the armed state 306, Yes in Block 370, processing continues to be triggered by a three-second time out as is utilized during the concerned state 304, described above.

[0115] If the predetermined number of three-second segments in both channels ECG1 and ECG2 have not been classified as shockable during both the gross morphology analysis and the beat-based analysis, the device does not transition from the concerned state 304 to the armed state 306, No in Block 370, and a determination as to whether to transition back to the not concerned state 302 is made, Block 372. The determination as to whether to transition from the concerned state 304 back to the not concerned state 302 is made, for example, by determining whether a heart rate estimate is less than a heart rate threshold level in both of the two channels ECG1 and ECG2, using the method for determining a heart rate estimate as described in U.S. Pat. No. 7,894,894 to Stadler et al., incorporated herein by reference in its entirety. If it is determined that the device should not transition to the not concerned state 302, i.e., either of the two heart rate estimates are greater than the heart rate threshold, No in Block 372, the process continues using the signal generated during a next three-second window, Block 341.

[0116] As described above, the determination of whether the sensing channels ECG1 and ECG2 are shockable or not shockable, Blocks 353, 355, 357, and 363-369, is performed by analyzing the gross morphology of a sensed waveform occurring within the three-second windows. The ECG signal is segmented into n-second intervals, i.e., 3 second intervals, that are used for determining gross morphology features of the three-second waveform. In particular, the gross morphology features are determined across an n-second time interval without relying on R-wave sensing and are therefore features making up the whole waveform signal that can be determined from the ECG signal independent of individual cardiac signals of the cardiac cycle, i.e., individual beats or R-waves contained within the three-second window that are within the entire three-second window. A single waveform in the n-second window begins at the start of the window, extends through entire window, ending at the end of the three-second window so that a single morphology determination is made for the single waveform included within the single three-second window.

[0117] On the other hand, multiple cardiac cycles, i.e., R-waves signals, are included within the three-second window, and therefore the n-second window may start and end at any time point relative to each of the individual R-wave signals irrespective of where an individual R-wave signal starts and ends, so that multiple individual beat-based determinations are made for the multiple beat waveforms included within the single three-second window.

[0118] Morphology features computed for the single waveform extending across the n-second time period are referred to as “gross” morphology features because the features are characteristics of the single signal, extending from the start to the end of the window, that is extracted, independent of cardiac cycle timing, from a time segment that includes multiple individual cardiac cycles. In contrast, morphology features extracted from the ECG signal during a cardiac cycle are referred to as “beat-based” features. Beat-based features are determined from an ECG signal segment over a time interval of one cardiac cycle of multiple cardiac cycles contained within a single three-second window. Beat-based features may be averaged or determined from multiple cardiac cycles but are representative of a single feature of the ECG signal during a cardiac cycle. Determination of a beat feature is dependent on identifying the timing of a cardiac cycle, or at least a sensed event such as an R-wave, as opposed to determining gross features independent of the cardiac cycle over a time segment that is typically longer than one cardiac cycle.

[0119] FIG. 10 is a flowchart of a beat-based analysis during detection of arrhythmias in a medical device according to an embodiment of the present disclosure. Therefore, as described above, in addition to performing the morphology analysis of the whole waveform within the three-second windows associated with each sensing channel ECG1 and ECG2, the device performs a beat-based analysis of the signal sensed simultaneously within both channels ECG1 and ECG2, Block 368. In particular, as illustrated in FIG. 10, for each three-second sensing window associated with the respective sensing channels ECG1 and ECG2, the device locates a beat, i.e., R-wave, Block 800, and compares the individual beat to a predetermined beat template, Block 802, such as a normal sinus rhythm template, for example. Based upon the comparison of the beat to the template, the device determines whether the beat is either a match beat or a

non-match beat by determining the extent to which the beat matches the template, Block 804. For example, in order to identify the beat as either a match beat or a non-match beat, the device determines in Block 804 whether the beat matches the sinus rhythm template within a predetermined percentage, such as 60 percent, for example. If the beat matches the template by the predetermined percentage or greater, Yes in Block 804, the beat is identified as a match beat and the number of match beats for the three-second window is updated, Block 806. If the beat matches the template by less than the predetermined percentage, No in Block 804, the beat is identified as a non-match beat and the number of non-match beats for the three-second window is updated, Block 808.

[0120] Once the beat is identified as likely being either a match beat or a non-match beat, the device determines whether the match/non-match determination has been made for all of the beats in the three-second window, Block 810. If the determination has not been made for all of the beats in the three-second window, No in Block 810, the process is repeated with another beat located within the three-second window. Once the determination has been made for all of the beats in the three-second window, Yes in Block 810, a determination is made as to whether the number of non-match beats in the three-second window is greater than a non-match threshold, Block 812. According to an embodiment of the disclosure, the non-match threshold is set as a predetermined percentage, such as 75 percent for example, so that if the number of individual beats in the three-second window that are identified as being non-match beats is greater than 75 percent of the number of all of the beats in the window, Yes in Block 812, the three-second window is identified as being shockable based on beat-based analysis, Block 814. On the other hand, if the number of individual beats in the three-second window that are identified as being non-match beats is not greater than 75 percent of the number of all of the beats in the window, No in Block 812, the three-second window is identified as being not shockable based on beat based analysis, Block 814. The beat-based analysis determination of the three-second windows as being shockable 814 or not shockable, Block 816 is then used in combination with the waveform morphology analysis of both of the three-second windows being shockable, Blocks 353, 357, 363 and 369 or both not shockable, Blocks 351, 355, 359, 365 and 367 to determine whether to transition to the next state, Block 370, as described above.

[0121] As can be seen in FIG. 4, the way in which both channels ECG1 and ECG2 could have been determined to be shockable can vary. First, if noise was not determined to be occurring in either channel, No in Block 346, but both channels are determined to have regular intervals, Yes in Block 356, and both channels are determined to be in the VT shock zone, Yes in Block 358, both of the sensing channels ECG1 and ECG2 are determined to be shockable, Block 359. Second, if noise was not determined to be occurring in either channel, No in Block 346, but both channels are not determined to have regular intervals, No in Block 356, and both channels are determined to be in the VF shock zone, Yes in Blocks 360 and 362, both of the sensing channels ECG1 and ECG2 are determined to be shockable.

[0122] However, if noise was determined to be occurring in one channel, Yes in Block 346, but the clean channel was determined to have regular intervals, Yes in Block 348, and to be in the VT shock zone, Yes in Block 352, both of the

sensing channels ECG1 and ECG2 are determined to be shockable, Block 353. Finally, if noise was determined to be occurring in one channel, Yes in Block 346, the clean channel was determined not to have regular intervals, No in Block 348, and both the clean and the noisy channel are determined to be in the VF shock zone, Yes in Blocks 350 and 354, both of the sensing channels ECG1 and ECG2 are determined to be shockable, Block 353.

[0123] In this way, both channels may be determined to be shockable based on a determination that both channels are either in the VF shock zone, Blocks 363 and 369, or Block 353 via Blocks 350 and 354, based on a determination that both channels are in the VT shock zone, Block 357, or based on a determination that only one channel, i.e., the clean channel, is within the VT shock zone, Block 353 via Block 352.

[0124] FIG. 11 is a flowchart of a beat-based analysis during detection of arrhythmias in a medical device according to an embodiment of the present disclosure. Therefore, according to an embodiment of the present disclosure, the device may initially identify how the three-second windows were determined to be shockable during the gross morphology analysis, i.e., by using both channels or only one channel, and based on this determination, determine which channels that are to be utilized in the beat morphology analysis.

[0125] Therefore, as illustrated in FIGS. 4 and 11, according to one embodiment, the device determines whether both channels were used in the identification of both channels being shockable, Block 820, so that if both channels were utilized, Yes in Block 820, the beat-based analysis, Block 368, is performed for both channels, Block 822, as described above in FIG. 10.

[0126] If both channels were not utilized, No in Block 820, the beat-based analysis, Block 368, is performed for only one channel, i.e., the clean channel, Block 824. In particular, the device locates a beat, i.e., R-wave, in only the clean channel, Block 800, and compares the individual beat to a predetermined beat template, Block 802, such as a normal sinus rhythm template, for example. Based upon the comparison of the beat to the template, the device determines whether the beat is either a match beat or a non-match beat by determining the extent to which the beat matches the template, Block 804. For example, in order to identify the beat as either a match beat or a non-match beat, the device determines in Block 804 whether the beat matches the sinus rhythm template within a predetermined percentage, such as 60 percent, for example. If the beat matches the template by the predetermined percentage or greater, Yes in Block 804, the beat is identified as a match beat and the number of match beats for the three-second window is updated, Block 806. If the beat matches the template by less than the predetermined percentage, No in Block 804, the beat is identified as a non-match beat and the number of non-match beats for the three-second window is updated, Block 808.

[0127] Once the beat is identified as likely being either a match beat or a non-match beat, the device determines whether the match/non-match determination has been made for all of the beats in the three-second window of only the clean channel, Block 810. If the determination has not been made for all of the beats in the three-second window for the clean channel, No in Block 810, the process is repeated with another beat located within the three-second window of the clean channel. Once the determination has been made for all

of the beats in the three-second window of the clean channel, Yes in Block 810, a determination is made as to whether the number of non-match beats in the three-second window is greater than a non-match threshold, Block 812. According to an embodiment of the disclosure, the non-match threshold is set as a predetermined percentage, such as 75 percent for example, so that if the number of individual beats in the three-second window that are identified as being non-match beats is greater than 75 percent of the number of all of the beats in the window, Yes in Block 812, the three-second window of the clean channel is identified as being shockable based on the beat-based analysis, Block 814. On the other hand, if the number of individual beats in the three-second window that are identified as being non-match beats is not greater than 75 percent of all of the number of the beats in the window, No in Block 812, the three-second window of the clean channel is identified as being not shockable based on the beat-based analysis, Block 814.

[0128] The decision as to whether to transition from the concerned operating state 304 to the armed operating state 306 in Block 370 is made based on the results of both an analysis of the morphology of the signal in the three-second window or windows for each sensing channel ECG1 and ECG2, and an analysis of morphology of individual beats or R-waves in the three-second window or windows for each sensing channel ECG1 and ECG2, as described above. In the instance where the beat-based analysis was performed for only one channel, i.e., the clean channel, Block 824, the determination of whether to transition to the next state, Block 370, would be satisfied if both the predetermined number of three-second segments in both channels ECG1 and ECG2 have been classified as shockable during the gross morphology analysis, and the beat-based analysis, Block 368, is satisfied for only the clean channel, and therefore the device transitions from the concerned state 304 to the armed state 306, Yes in Block 370. If the predetermined number of three-second segments in both channels ECG1 and ECG2 have not been classified as shockable during both the gross morphology analysis and the beat-based analysis of only the clean channel, the device does not transition from the concerned state 304 to the armed state 306, No in Block 370, and a determination as to whether to transition back to the not concerned state 302 is made, Block 372, as described above.

[0129] Thus, a method and apparatus for discriminating a cardiac event have been presented in the foregoing description with reference to specific embodiments. It is appreciated that various modifications to the referenced embodiments may be made without departing from the scope of the disclosure as set forth in the following claims.

We claim:

1. A method comprising:

obtaining a first cardiac signal sensed on a first sensing vector formed between a first electrode and a second electrode;

identifying a plurality of analysis windows, each of the plurality of analysis windows extending a predetermined amount of time and including a respective segment of the first cardiac signal having a plurality of R-wave sense events;

analyzing, for each of the plurality of analysis windows, a gross morphology of the respective segment of the first cardiac signal across the entire analysis window;

- analyzing, for each of the plurality of analysis windows, a beat-based morphology of each individual one of the plurality of R-wave sense events of the respective segment of the first cardiac signal within the analysis window;
- classifying analysis windows of the plurality of analysis windows as shockable when both the gross morphology analysis associated with the respective analysis window results in a shockable classification and the beat-based morphology analysis associated with the respective analysis window results in a shockable classification;
- detecting a tachyarrhythmia when a threshold number of the plurality of analysis windows are classified as shockable; and
- delivering an electrical therapy in response to detecting the tachyarrhythmia.
2. The method of claim 1, wherein analyzing, for each of the plurality of analysis windows, the beat-based morphology of each individual one of the plurality of R-wave sense events of the respective segment of the first cardiac signal within the analysis window comprises, for each of the plurality of R-waves within a respective analysis window:
- comparing a beat morphology of the respective R-wave sense event to a beat template;
 - classifying the respective R-wave sense event as a non-match beat when the respective comparison does not meet a match criteria; and
 - classifying the analysis window as shockable when the number of R-wave sense events classified as non-match beats is greater than a threshold.
3. The method of claim 2, wherein the threshold is equal to 75 percent of the number of R-wave sense events in the analysis window.
4. The method of claim 2, further comprising classifying the analysis window as not shockable when the number of R-wave sense events classified as non-match beats is not greater than the threshold.
5. The method of claim 1, wherein analyzing, for each of the plurality of analysis windows, a gross morphology of the respective segment of the first cardiac signal across the entire analysis window comprises:
- determining whether the segment of the cardiac signal in the analysis window is noisy;
 - in response to determining that the segment of the cardiac signal in the respective window is not noisy, determining whether R-R intervals between consecutive R-wave sense events within the analysis window are stable or unstable;
 - when the R-R intervals within the analysis window are stable, determining whether the segment of the cardiac signal is within a VT zone based at least on the low slope content and the spectral width of the segment of the cardiac signal;
 - when the R-R intervals within the analysis window are stable, determining whether the segment of the cardiac signal is within a VT zone based at least on the low slope content and the spectral width of the segment of the cardiac signal; and
 - classifying the analysis window as shockable based on the gross morphology analysis in response to determining the segment of the cardiac signal is within the VT zone or the VF zone.
6. The method of claim 1, wherein the gross morphology analysis and the beat-based morphology analysis occur in a second detection state, the method further comprising transitioning from a first detection state to the second detection state based on a heart rate estimate.
7. The method of claim 1, further comprising:
- obtaining a second cardiac signal sensed on a second sensing vector formed between a third electrode and a fourth electrode, at least one of the third electrode and the fourth electrode being different than the first electrode and the second electrode;
 - identifying a second plurality of analysis windows, each of the second plurality of analysis windows extending the predetermined amount of time and including a respective segment of the second cardiac signal having a plurality of R-wave sense events;
 - analyzing, for each of the second plurality of analysis windows, a gross morphology of the respective segment of the second cardiac signal across the entire analysis window;
 - analyzing, for each of the second plurality of analysis windows, a beat-based morphology of each individual one of the plurality of R-wave sense events of the respective segment of the second cardiac signal within the analysis window;
 - classifying analysis windows of the second plurality of analysis windows as shockable when both the gross morphology analysis associated with the respective analysis window results in a shockable classification and the beat-based morphology analysis associated with the respective analysis window results in a shockable classification; and
 - detecting the tachyarrhythmia when the threshold number of the first plurality of analysis windows are classified as shockable and a threshold number of the second plurality of analysis windows are classified as shockable.
8. The method of claim 7, wherein the gross morphology analysis of the segments of the first and second cardiac signal includes determining one or more of the segments within the first plurality of analysis windows of the first cardiac signal are noisy, the method further comprising:
- determining not to utilize the respective ones of the first plurality of analysis windows of the first cardiac signal determined to be noisy in the gross morphology analysis of the first cardiac signal;
 - determining not to utilize the respective ones of the first plurality of analysis windows of the first cardiac signal determined to be noisy in the beat-based morphology analysis of the first cardiac signal.
9. A medical device comprising:
- a sense amplifier configured to obtain a first cardiac signal sensed on a first sensing vector formed between a first electrode and a second electrode;
 - a processor configured to:
 - identify a plurality of analysis windows, each of the plurality of analysis windows extending a predetermined amount of time and including a respective segment of the first cardiac signal having a plurality of R-wave sense events;
 - analyze, for each of the plurality of analysis windows, a gross morphology of the respective segment of the first cardiac signal across the entire analysis window;

- analyze, for each of the plurality of analysis windows, a beat-based morphology of each individual one of the plurality of R-wave sense events of the respective segment of the first cardiac signal within the analysis window;
- classify analysis windows of the plurality of analysis windows as shockable when both the gross morphology analysis associated with the respective analysis window results in a shockable classification and the beat-based morphology analysis associated with the respective analysis window results in a shockable classification;
- detect a tachyarrhythmia when a threshold number of the plurality of analysis windows are classified as shockable; and
- one or more high voltage capacitors configured to be charged in response to detecting the tachyarrhythmia and discharged between a pair of cardioversion-defibrillation electrodes to deliver an electrical therapy in response to detecting the tachyarrhythmia.
- 10.** The medical device of claim **9**, wherein the processor is configured to, during the beat-based morphology for each of the plurality of R-waves within a respective analysis window:
- compare a beat morphology of the respective R-wave sense event to a beat template;
 - classify the respective R-wave sense event as a non-match beat when the respective comparison does not meet a match criteria; and
 - classify the analysis window as shockable when the number of R-wave sense events classified as non-match beats is greater than a threshold.
- 11.** The medical device of claim **10**, wherein the threshold is equal to **75** percent of the number of R-wave sense events in the analysis window.
- 12.** The medical device of claim **10**, wherein the processor is further configured to classify the analysis window as not shockable when the number of R-wave sense events classified as non-match beats is not greater than the threshold.
- 13.** The medical device of claim **9**, wherein the processor is configured to, during the gross morphology analysis of the respective segment of the first cardiac signal:
- determine whether the segment of the cardiac signal in the analysis window is noisy;
 - in response to determining that the segment of the cardiac signal in the respective window is not noisy, determine whether R-R intervals between consecutive R-wave sense events within the analysis window are stable or unstable;
 - when the R-R intervals within the analysis window are stable, determine whether the segment of the cardiac signal is within a VT zone based at least on the low slope content and the spectral width of the segment of the cardiac signal;
 - when the R-R intervals within the analysis window are stable, determine whether the segment of the cardiac signal is within a VT zone based at least on the low slope content and the spectral width of the segment of the cardiac signal; and
- classify the analysis window as shockable based on the gross morphology analysis in response to determining the segment of the cardiac signal is within the VT zone or the VF zone.
- 14.** The medical device of claim **9**, wherein the gross morphology analysis and the beat-based morphology analysis occur in a second detection state, the processor further configured to transition from a first detection state to the second detection state based on a heart rate estimate.
- 15.** The medical device of claim **9**, further comprising:
- a second sense amplifier configured to obtain a second cardiac signal sensed on a second sensing vector formed between a third electrode and a fourth electrode, at least one of the third electrode and the fourth electrode being different than the first electrode and the second electrode;
- the processor further configured to:
- identify a second plurality of analysis windows, each of the second plurality of analysis windows extending the predetermined amount of time and including a respective segment of the second cardiac signal having a plurality of R-wave sense events;
 - analyze, for each of the second plurality of analysis windows, a gross morphology of the respective segment of the second cardiac signal across the entire analysis window;
 - analyze, for each of the second plurality of analysis windows, a beat-based morphology of each individual one of the plurality of R-wave sense events of the respective segment of the second cardiac signal within the analysis window;
 - classify analysis windows of the second plurality of analysis windows as shockable when both the gross morphology analysis associated with the respective analysis window results in a shockable classification and the beat-based morphology analysis associated with the respective analysis window results in a shockable classification; and
 - detect the tachyarrhythmia when the threshold number of the first plurality of analysis windows are classified as shockable and a threshold number of the second plurality of analysis windows are classified as shockable.
- 16.** The medical device of claim **15**, wherein the gross morphology analysis of the segments of the first and second cardiac signal includes determining one or more of the segments within the first plurality of analysis windows of the first cardiac signal are noisy, the processor further configured to:
- determine not to utilize the respective ones of the first plurality of analysis windows of the first cardiac signal determined to be noisy in the gross morphology analysis of the first cardiac signal;
 - determine not to utilize the respective ones of the first plurality of analysis windows of the first cardiac signal determined to be noisy in the beat-based morphology analysis of the first cardiac signal.
- 17.** The medical device of claim **9**, wherein the predetermined amount of time comprises 3-seconds.

专利名称(译)	使用两个传感矢量区分医疗设备中的心动过速事件的方法和设备		
公开(公告)号	US20180064949A1	公开(公告)日	2018-03-08
申请号	US15/801522	申请日	2017-11-02
[标]申请(专利权)人(译)	美敦力公司		
申请(专利权)人(译)	美敦力公司, INC.		
当前申请(专利权)人(译)	美敦力公司, INC.		
[标]发明人	ZHANG XUSHENG		
发明人	ZHANG, XUSHENG		
IPC分类号	A61N1/39 A61B5/04 A61B5/042 A61B5/0452 A61B5/046 A61B5/0464 A61B5/00		
CPC分类号	A61B5/04011 A61B5/0422 A61B5/04525 A61B5/046 A61B5/0464 A61N1/3987 A61B5/7207		
其他公开文献	US10500406		
外部链接	Espacenet USPTO		

摘要(译)

一种用于检测心脏事件的方法和医疗装置，该方法和医疗装置包括：感测来自多个电极的心脏信号，形成在预定时间段期间感测心脏信号的第一间隔的第一感测矢量；以及第二感测矢量，同时感测第二间隔心脏信号的第二处理，响应于第一间隔和第二间隔的第一处理以及响应于第一处理中的一个或两个而将第一间隔和第二间隔中的每一个识别为是可震动和不可震动中的一个第一间隔和第二间隔，第二处理与第一处理不同，并且响应于将第一间隔和第二间隔中的每一个识别为在第一间隔和第二间隔中的每一个中是休克和不休克中的一个，确定是否递送心脏事件的治疗对第一间隔和第一间隔的第一处理和第二处理两者的响应第二个时间间隔。

