



US 20150182164A1

(19) **United States**  
(12) **Patent Application Publication**  
**Utter, II**

(10) **Pub. No.: US 2015/0182164 A1**  
(43) **Pub. Date: Jul. 2, 2015**

- (54) **WEARABLE RING FOR SLEEP MONITORING**
- (71) Applicant: **Max Everett Utter, II**, San Francisco, CA (US)
- (72) Inventor: **Max Everett Utter, II**, San Francisco, CA (US)
- (73) Assignee: **AliphCom**, San Francisco, CA (US)
- (21) Appl. No.: **14/246,971**
- (22) Filed: **Apr. 7, 2014**

**Related U.S. Application Data**

- (63) Continuation of application No. 14/145,856, filed on Dec. 31, 2013.

**Publication Classification**

- (51) **Int. Cl.**  
*A61B 5/00* (2006.01)  
*A61B 5/04* (2006.01)  
*A61B 5/053* (2006.01)  
*A61B 5/0488* (2006.01)

- A61B 5/11* (2006.01)  
*A61B 5/0205* (2006.01)
- (52) **U.S. Cl.**  
 CPC ..... *A61B 5/4842* (2013.01); *A61B 5/0022* (2013.01); *A61B 5/1107* (2013.01); *A61B 5/0205* (2013.01); *A61B 5/053* (2013.01); *A61B 5/0533* (2013.01); *A61B 5/0488* (2013.01); *A61B 5/04001* (2013.01); *A61B 5/681* (2013.01)

(57) **ABSTRACT**

A wearable ring (e.g., on a digit of a hand and/or a toe of a foot) may include sensors for generating motion signals in response to a user's body motion, for generating force signals in response to force exerted by a body portion, for generating biometric signals indicative of biometric activity in the body (e.g., heart rate, respiration, arousal), and for generating location signals based on user location. The sensor signals may be processed to monitor parameters that may positively or negatively impact a state of sleep of the user (e.g., time of sleep, quality of sleep, hydration, inflammation, contraction, fatigue, TRHR, accelerometry, arousal of the SNS, etc.). Data derived from the processed signals may be presented (e.g., visually, sound, email, text message, tactile, webpage, etc.) to the user in a format (e.g., reports, notifications, coaching, avoidance, mood) intended to instruct/encourage the user to improve their state of sleep.

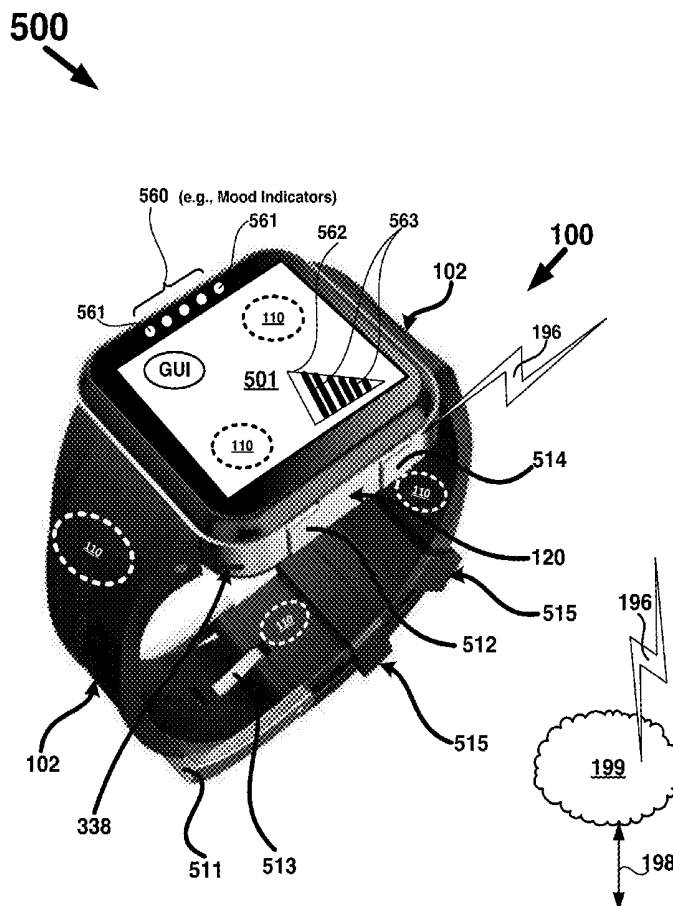

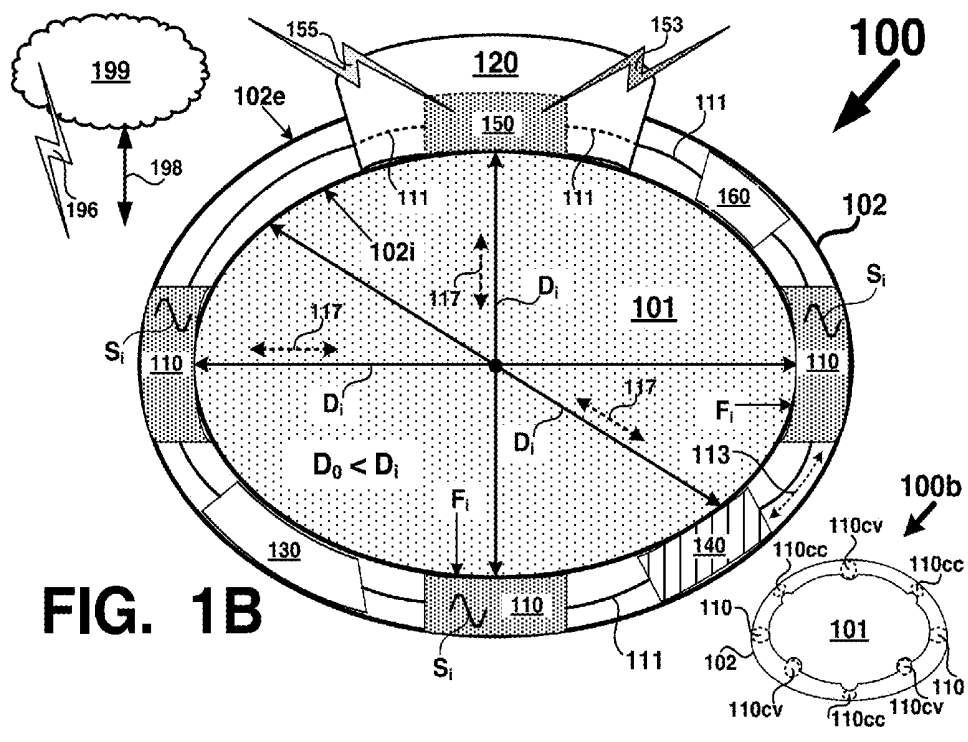
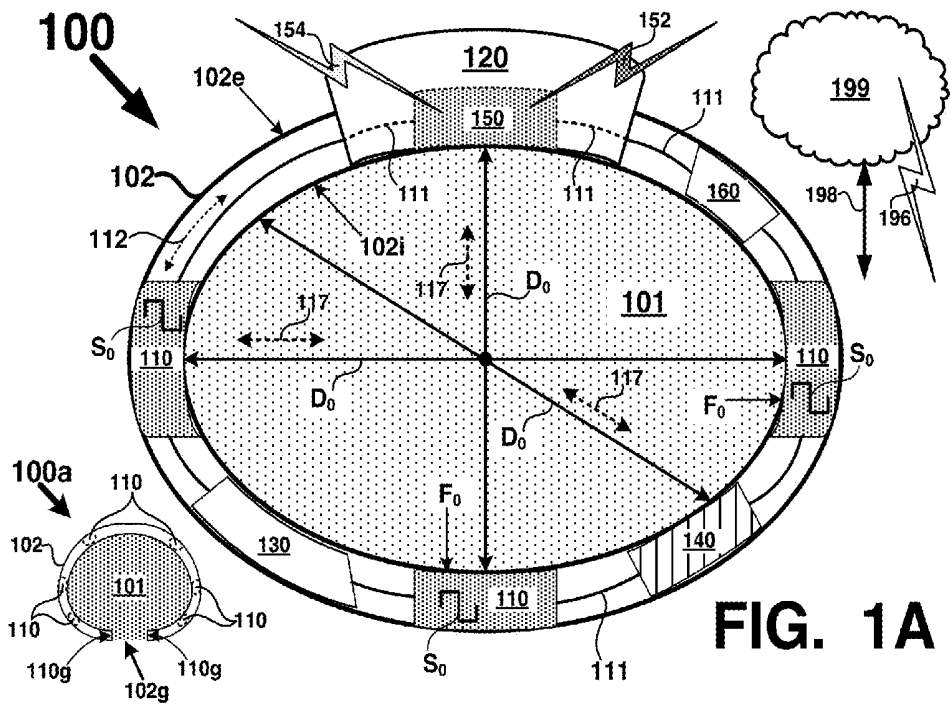

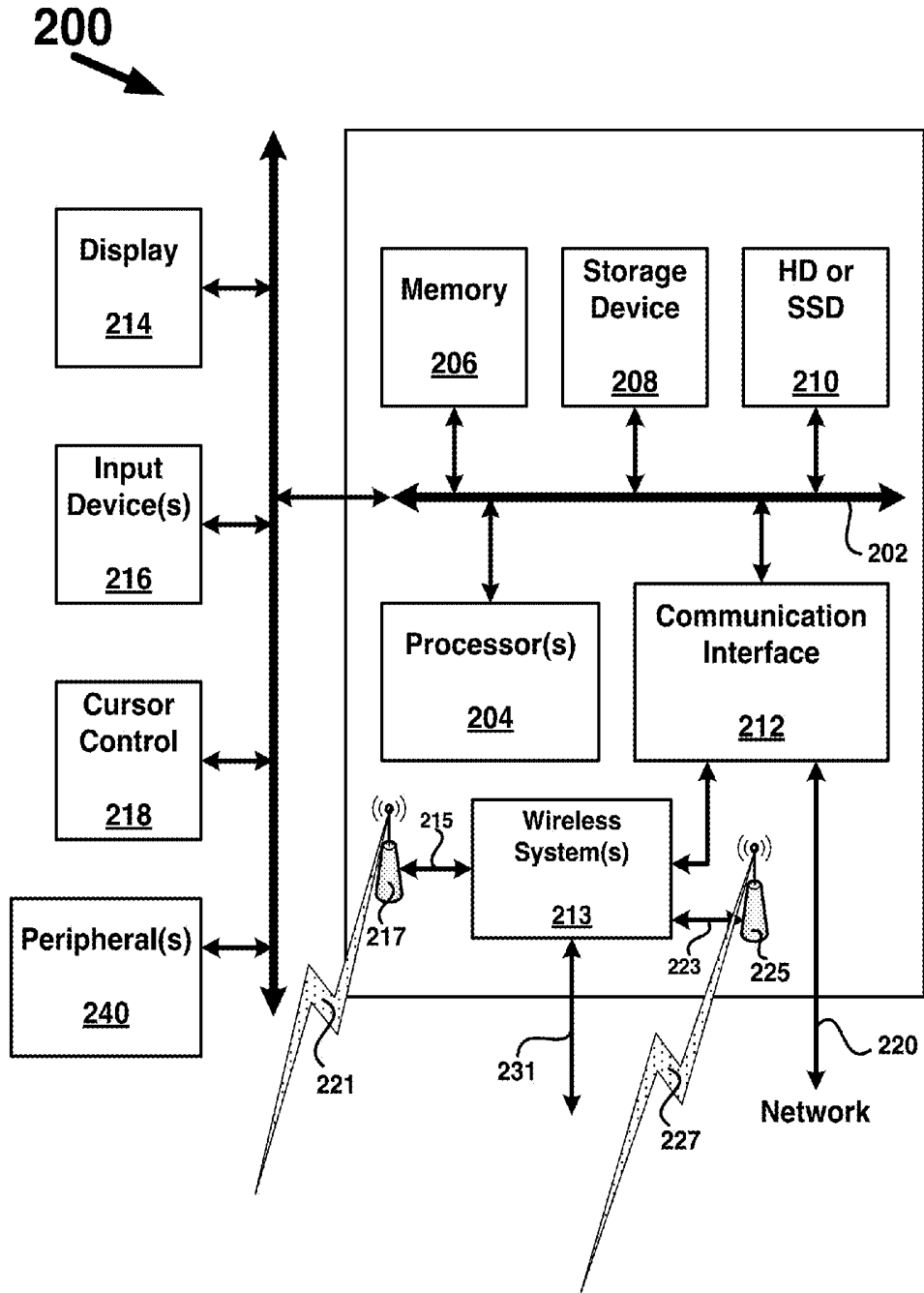
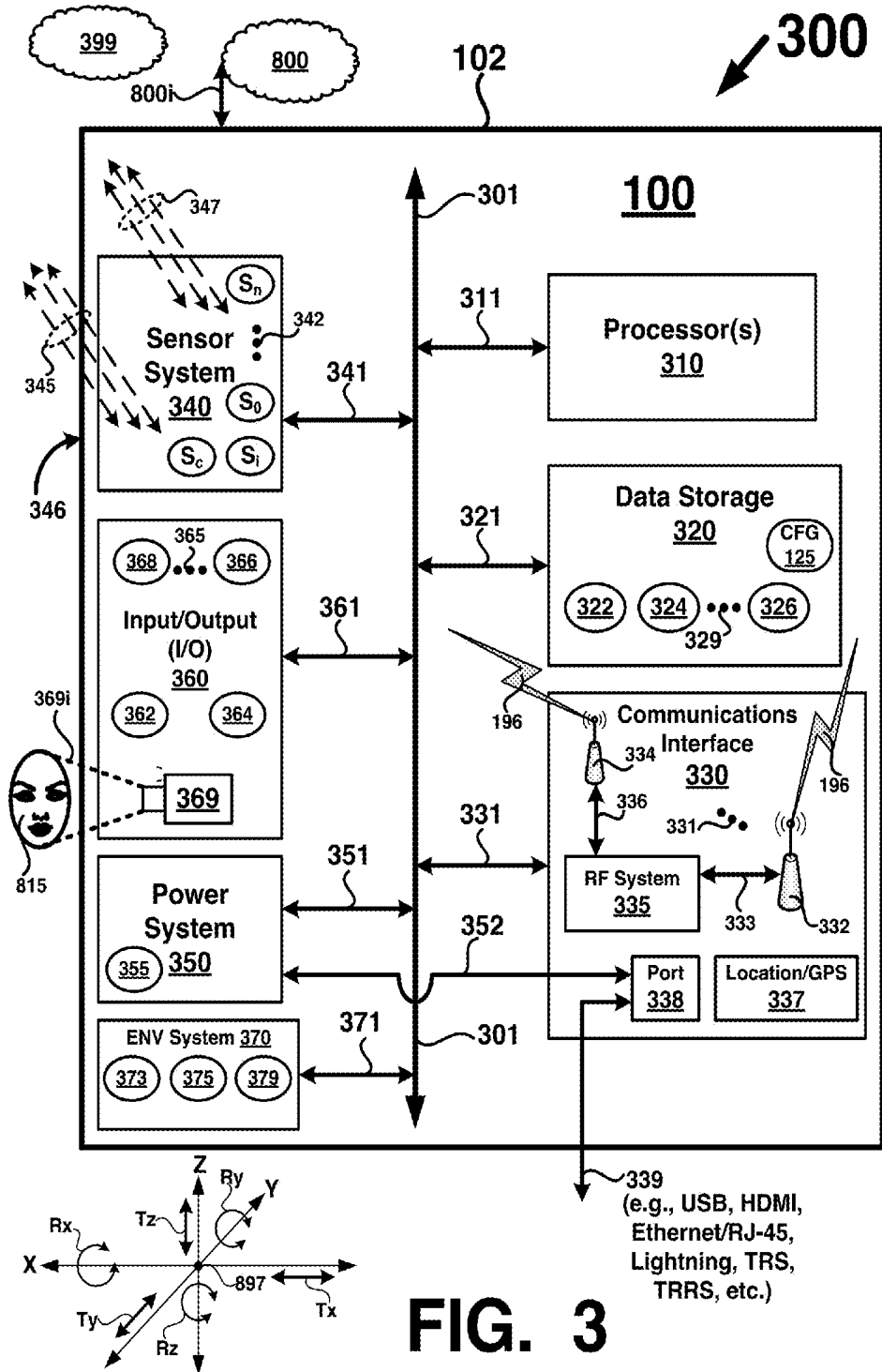
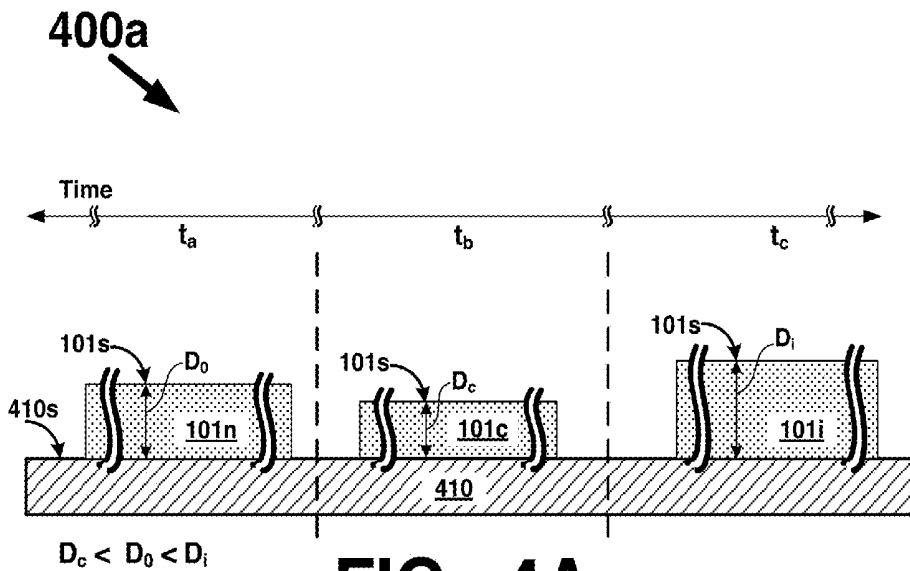
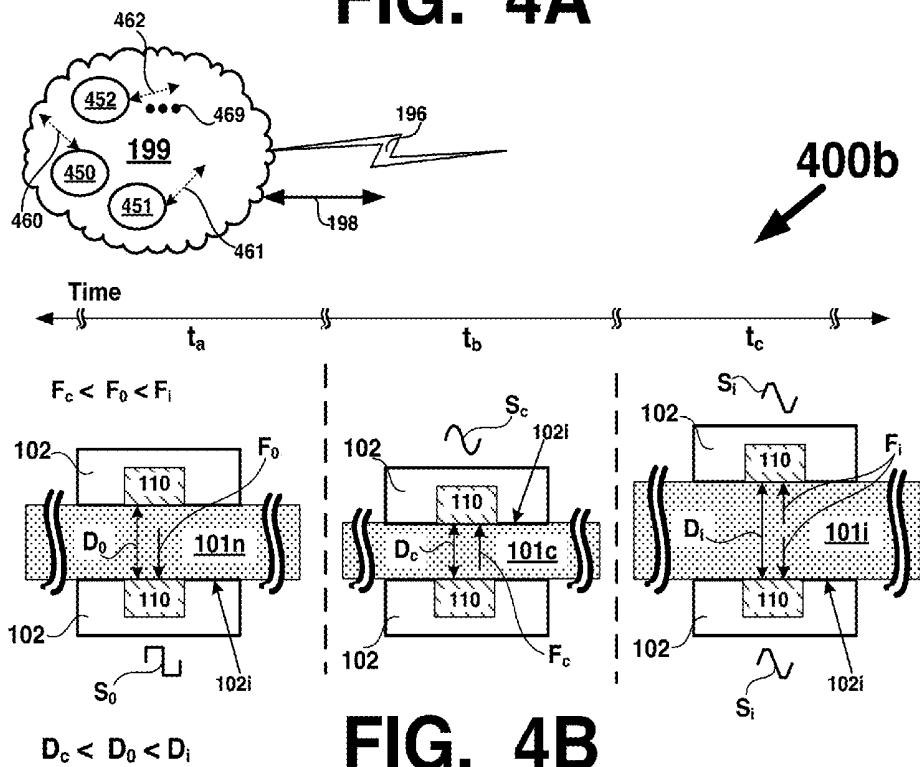

FIG. 2





**FIG. 4A**



**FIG. 4B**

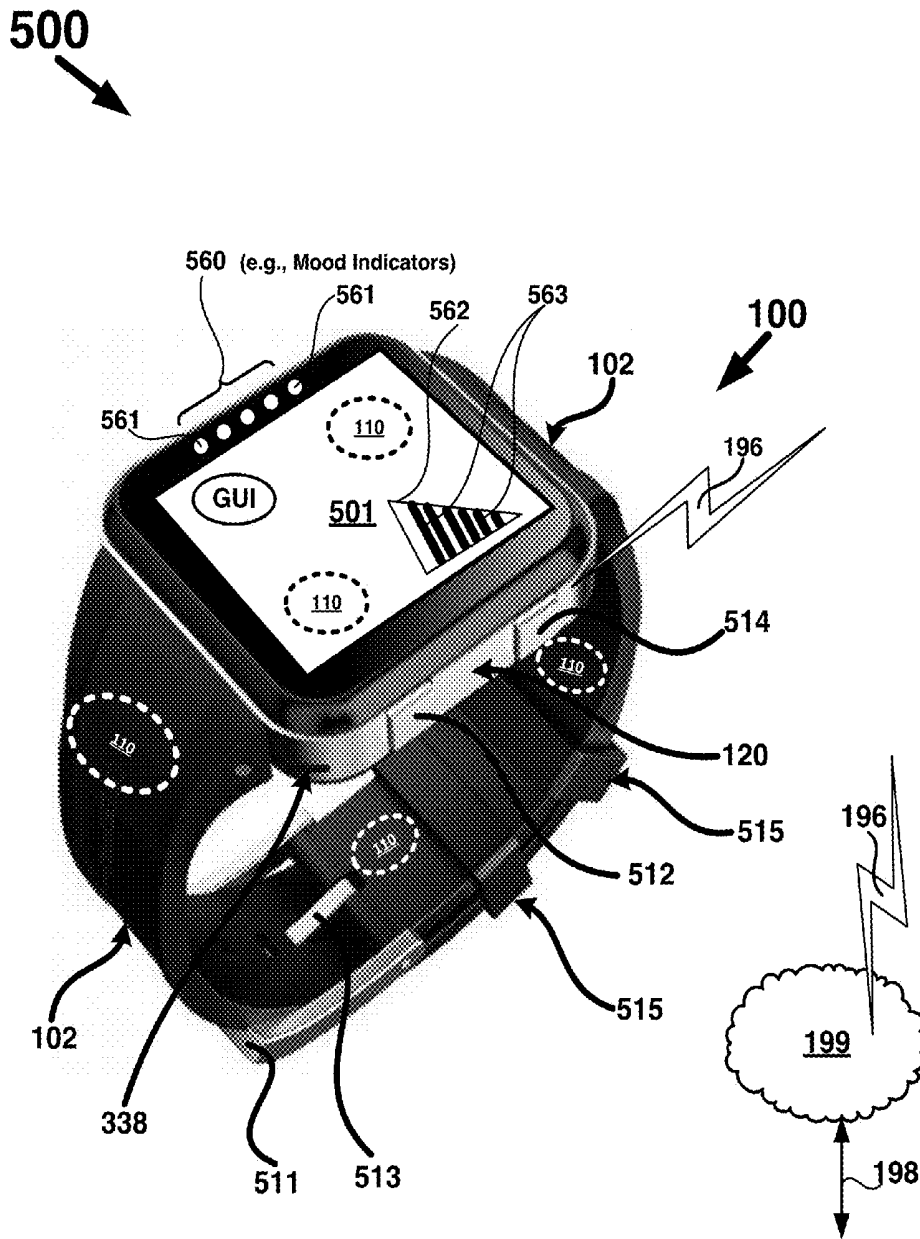

FIG. 5

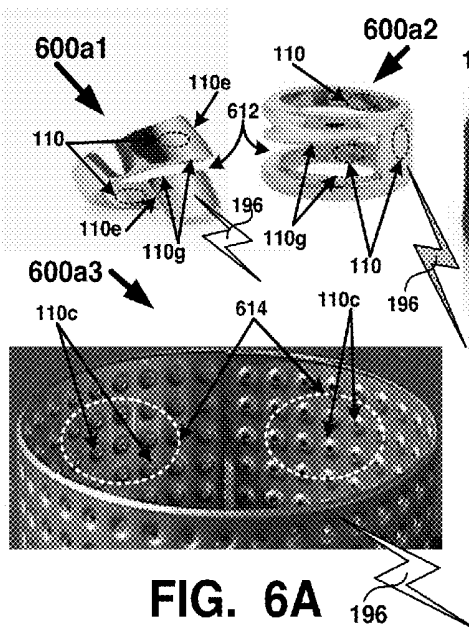

FIG. 6A

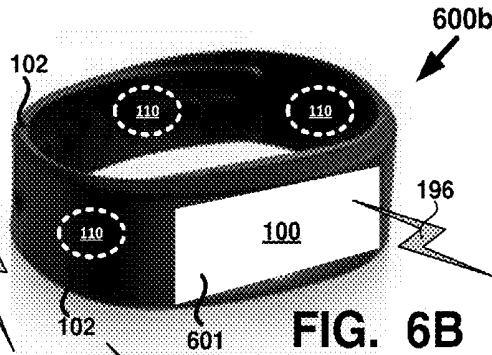

FIG. 6B

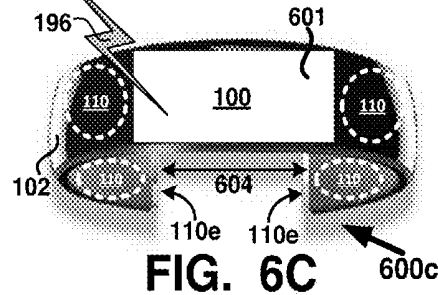

FIG. 6C

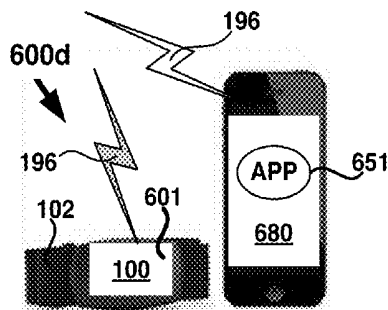

FIG. 6D

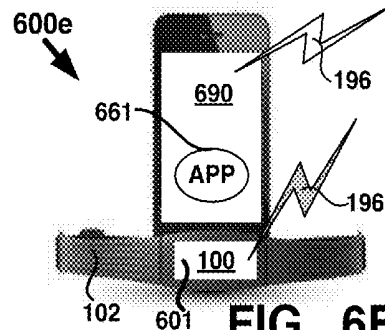

FIG. 6E

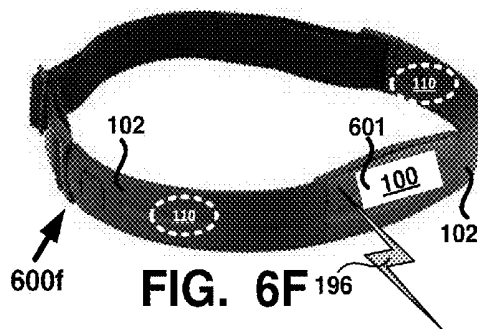

FIG. 6F

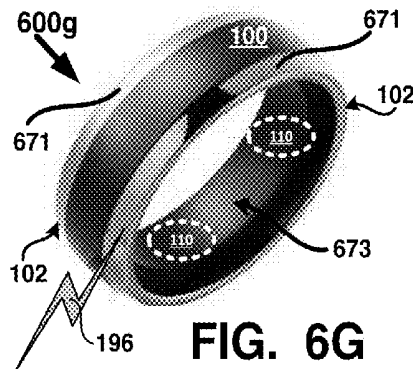

FIG. 6G

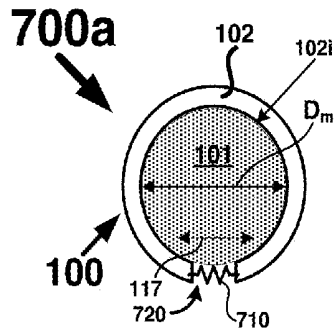

FIG. 7A

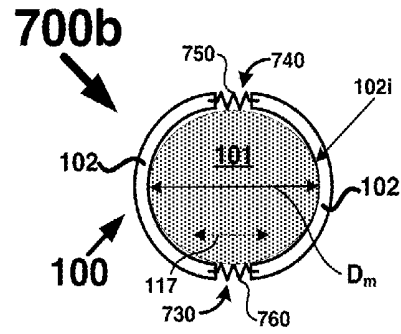

FIG. 7B

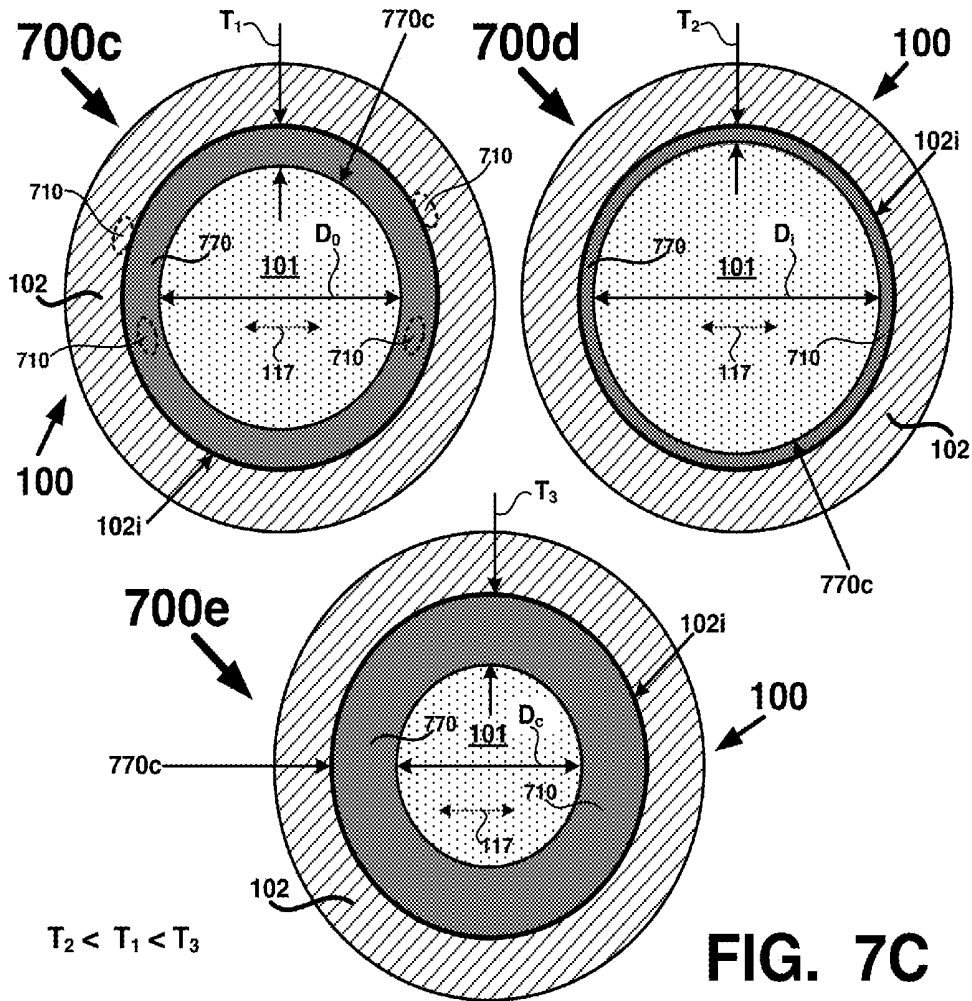
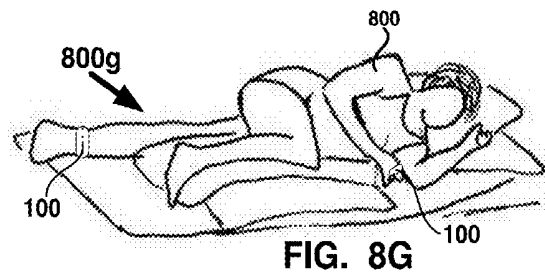
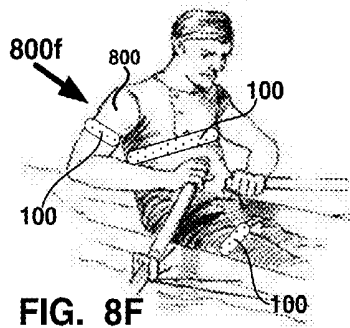
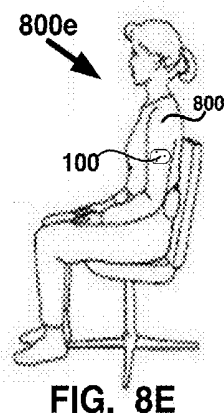
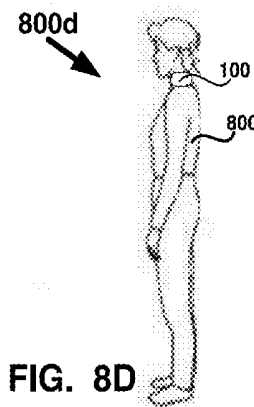
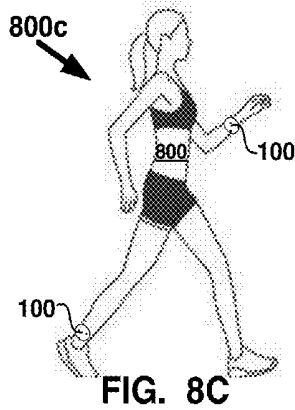
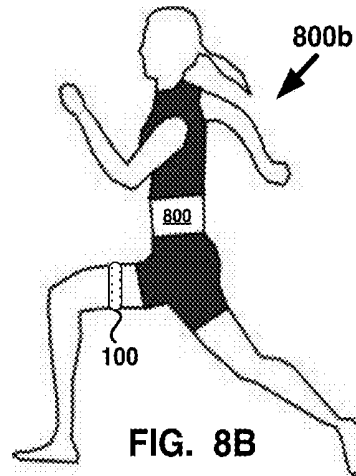
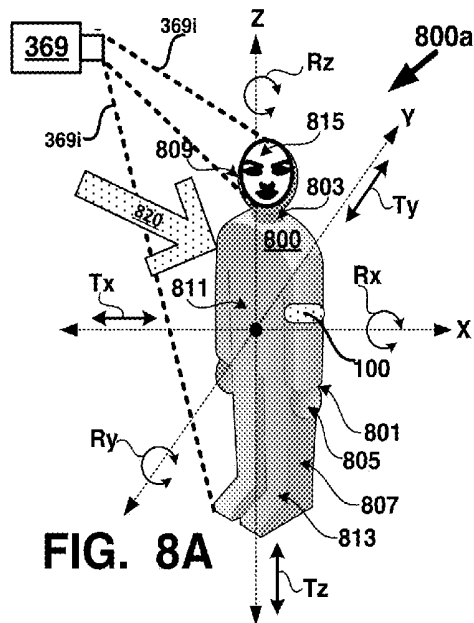

FIG. 7C



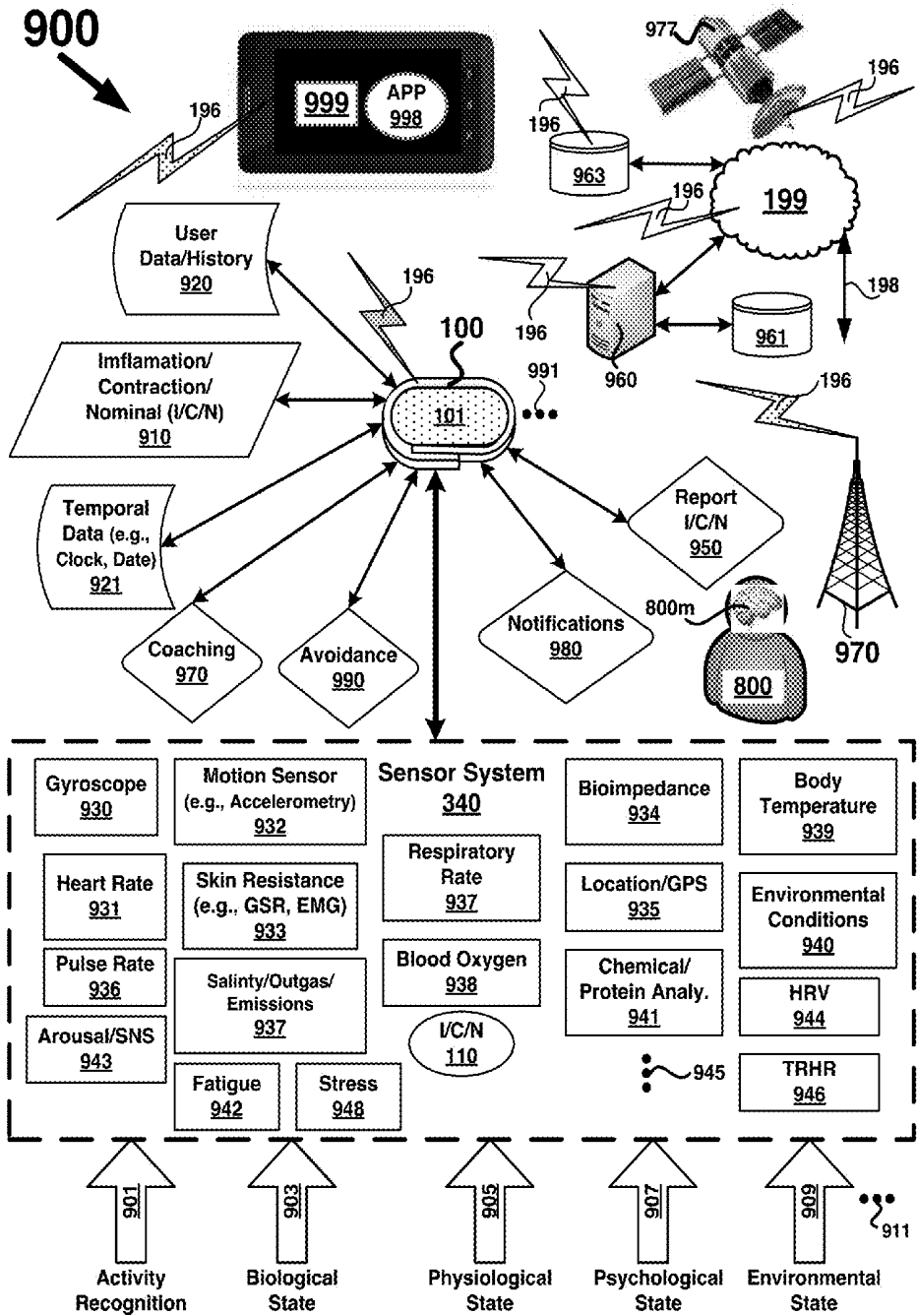
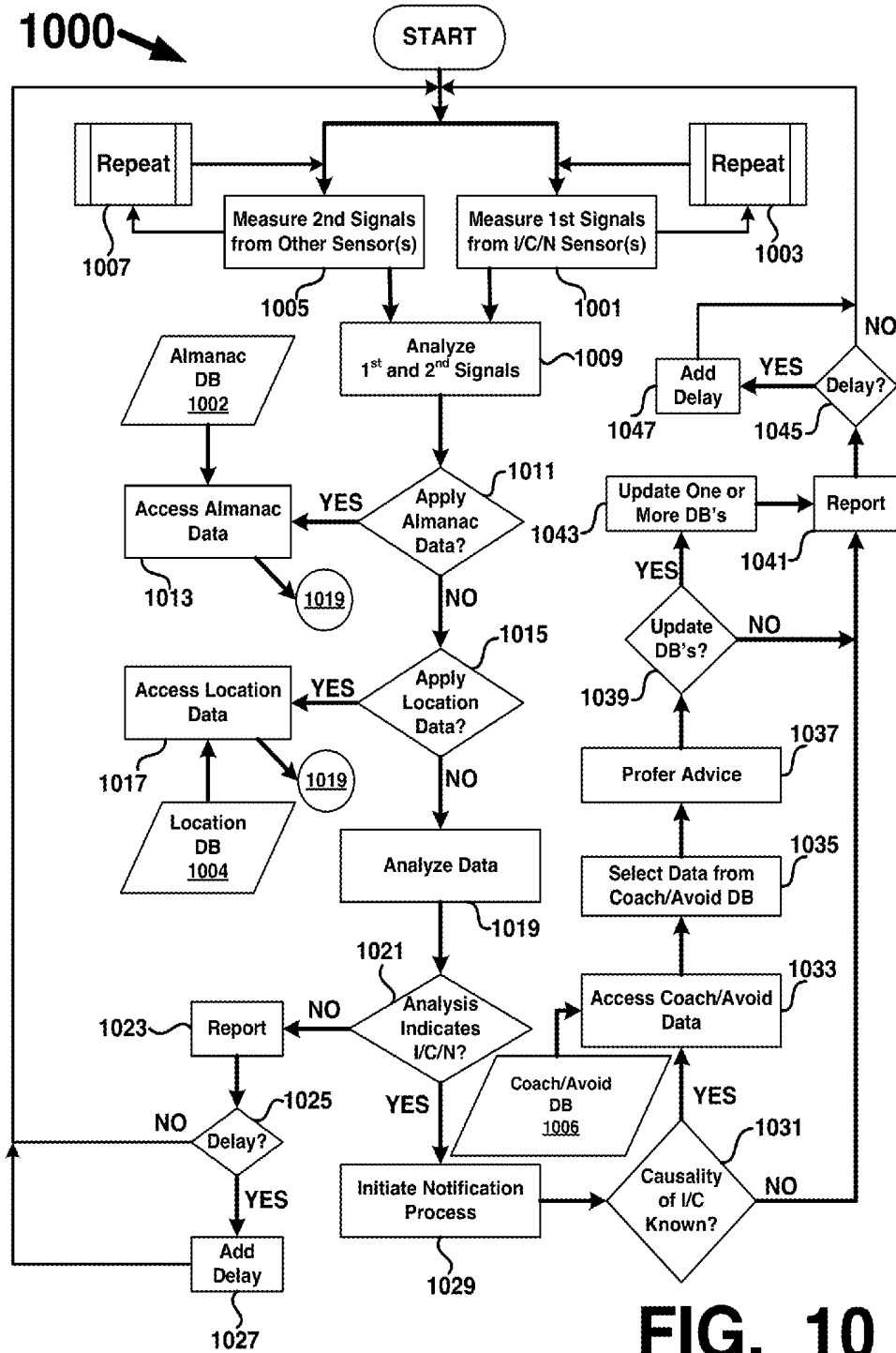

FIG. 9



**FIG. 10**

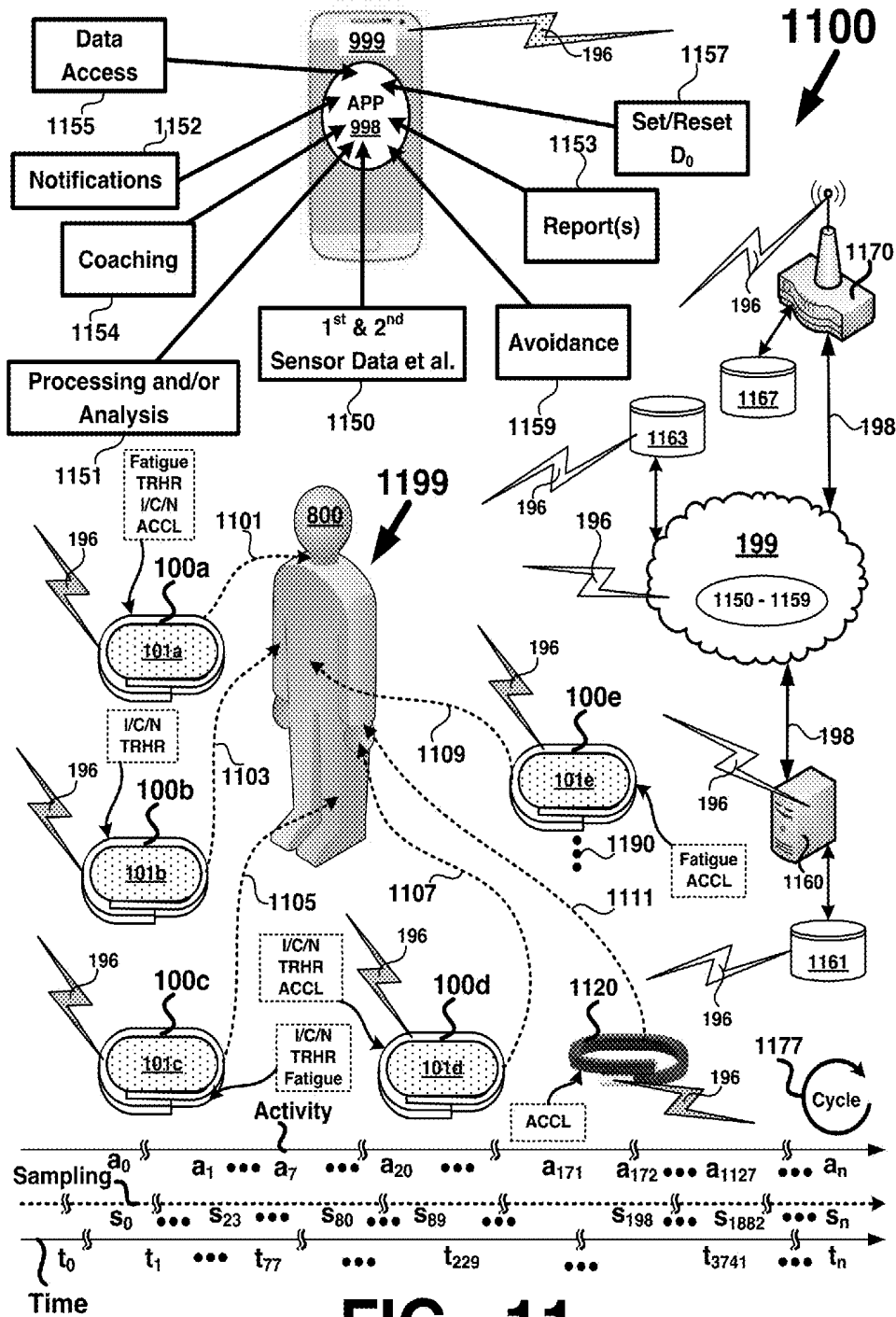

FIG. 11

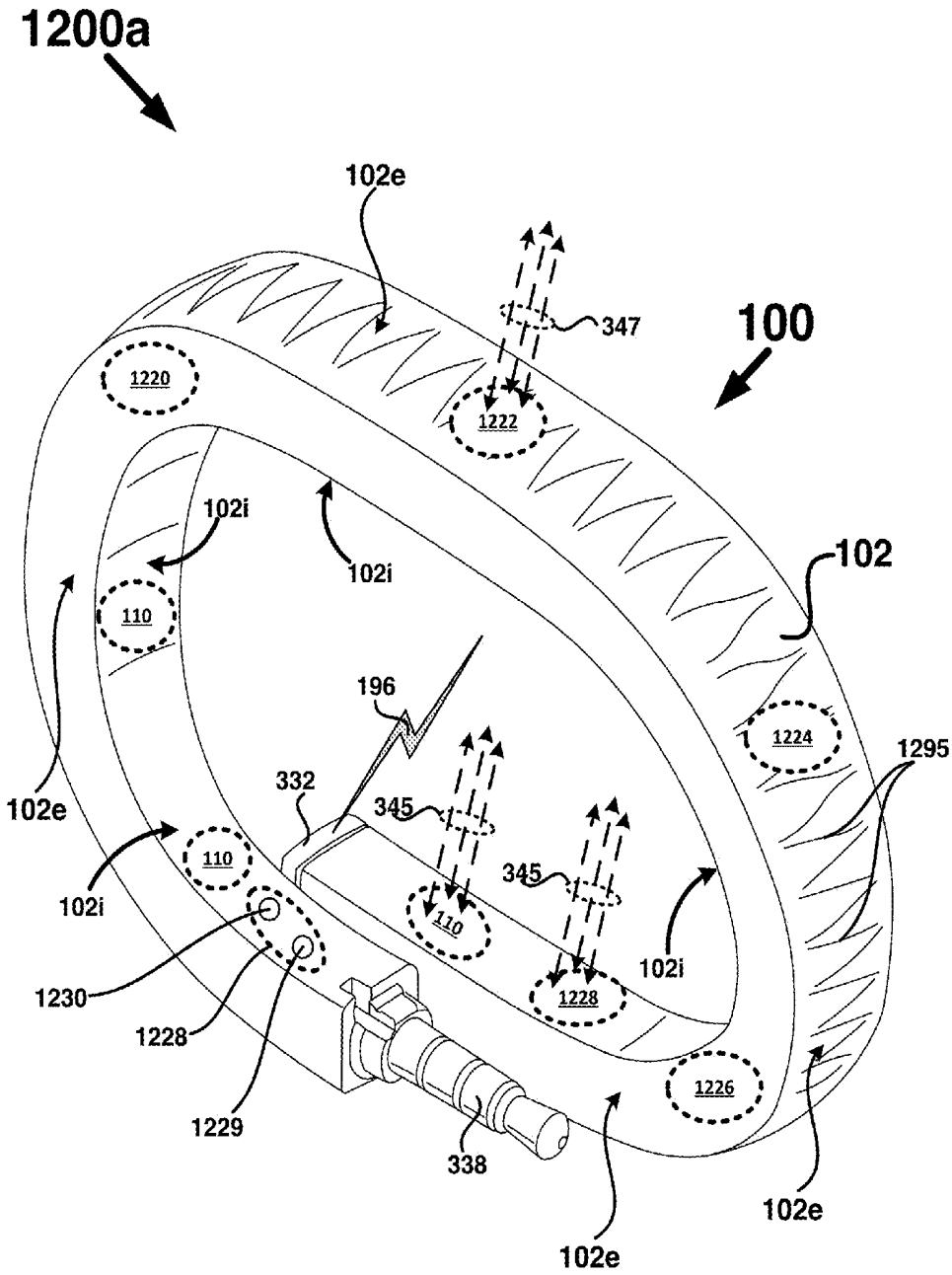
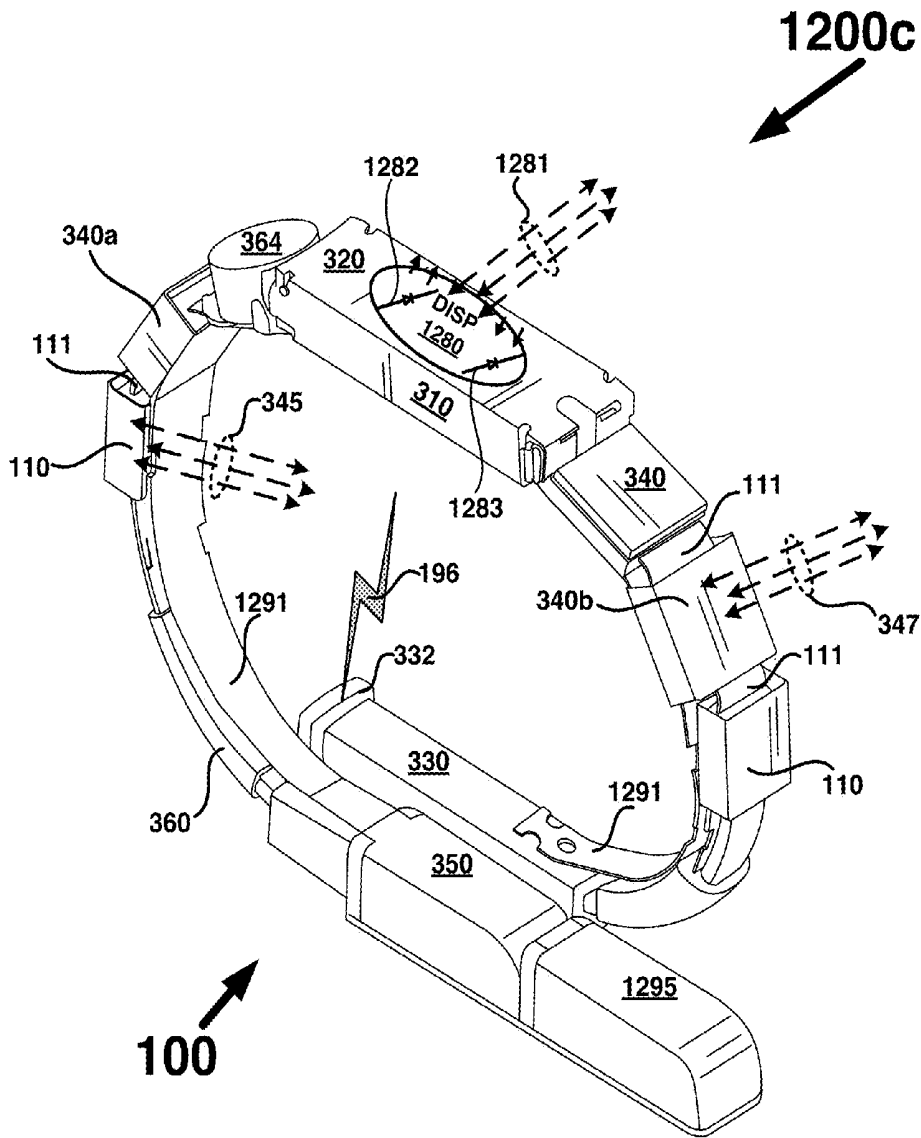

FIG. 12A





**FIG. 12C**



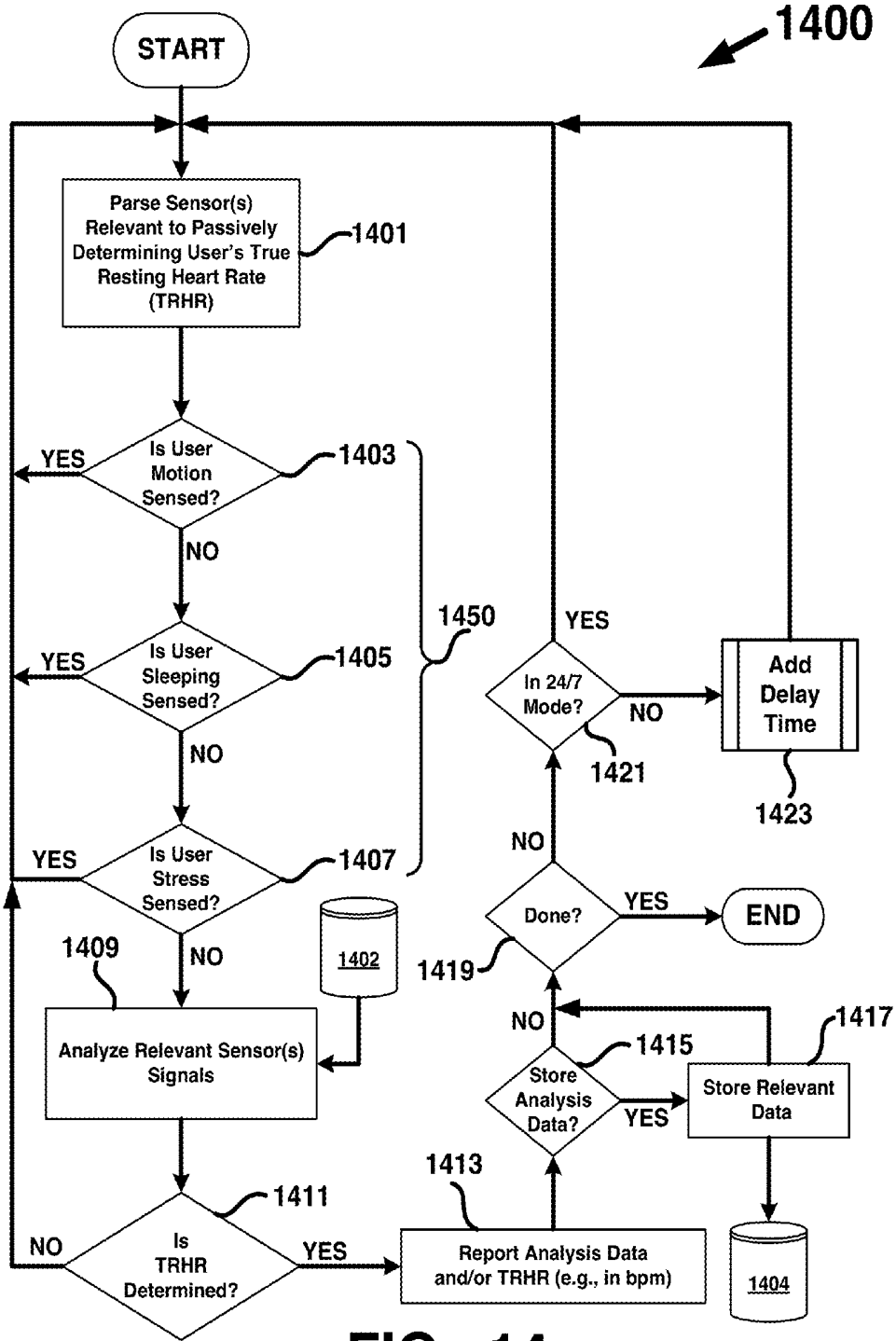

FIG. 14

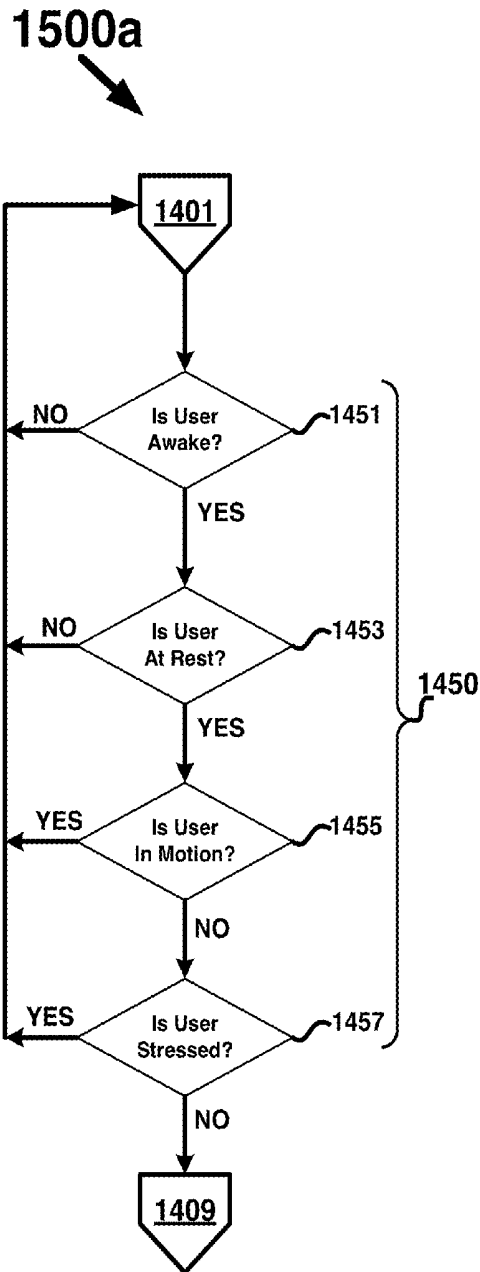

FIG. 15A

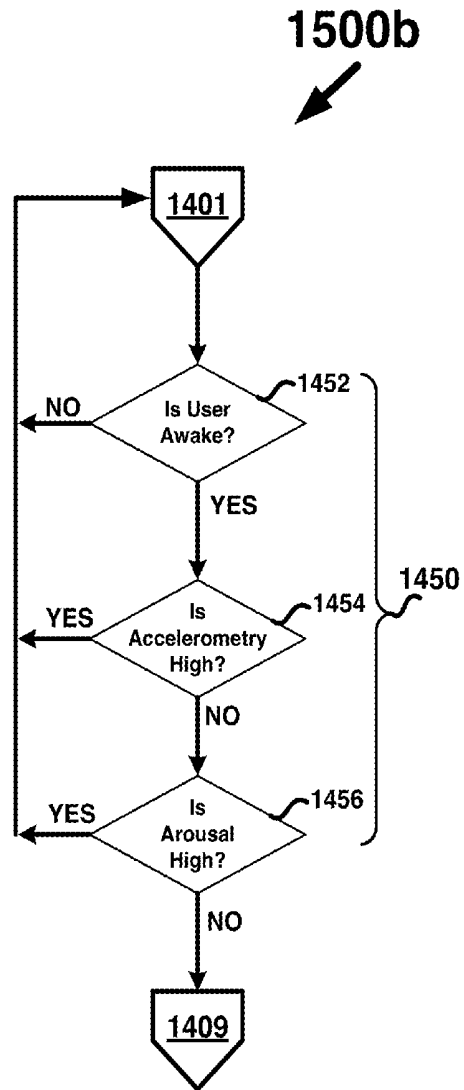

FIG. 15B

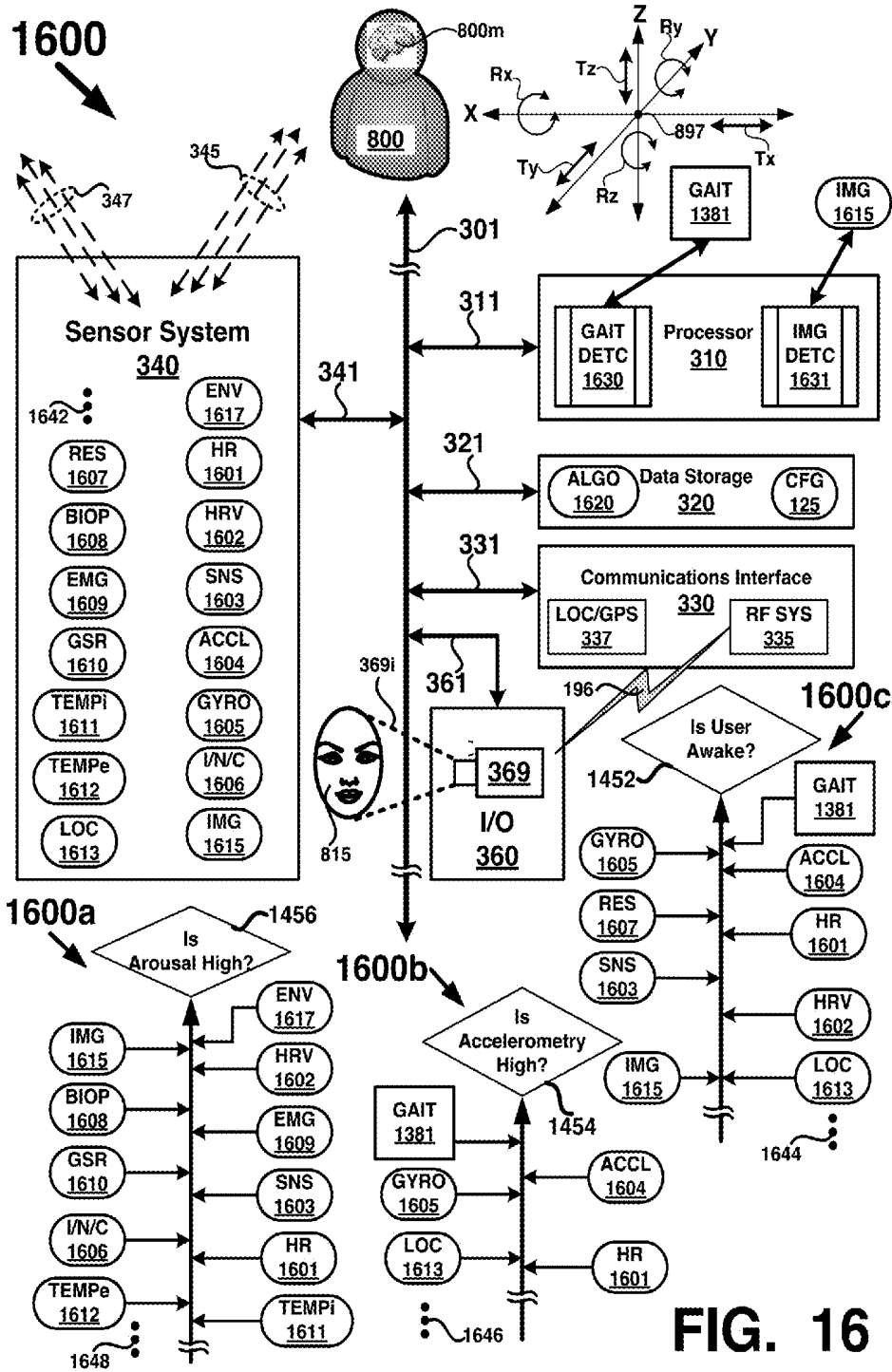

FIG. 16

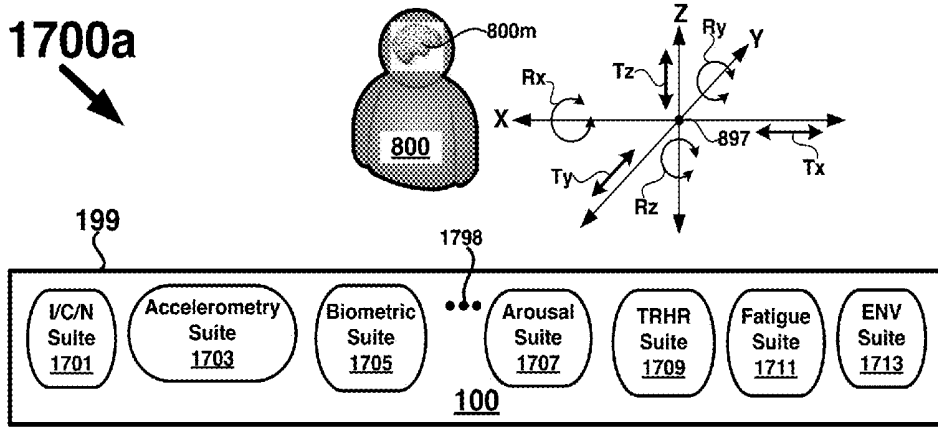

FIG. 17A

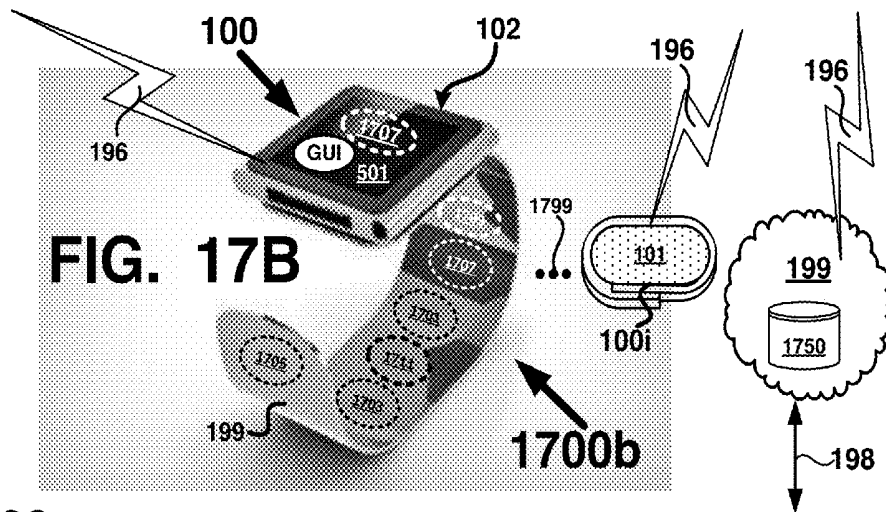

FIG. 17B

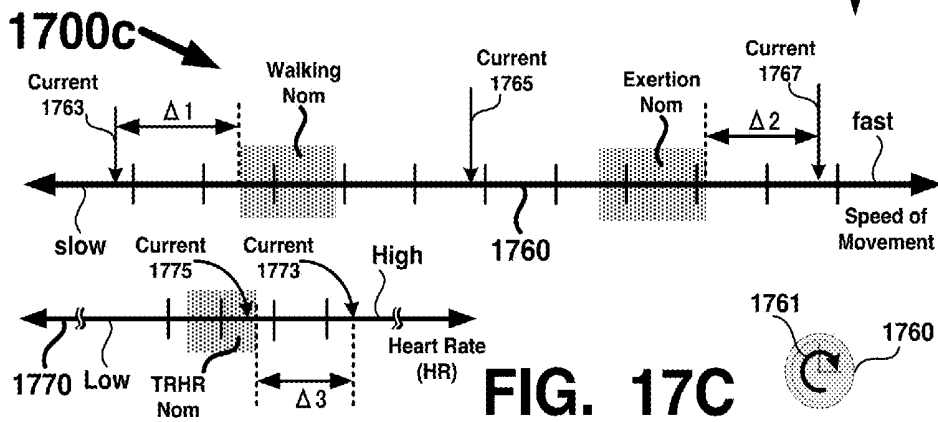

FIG. 17C

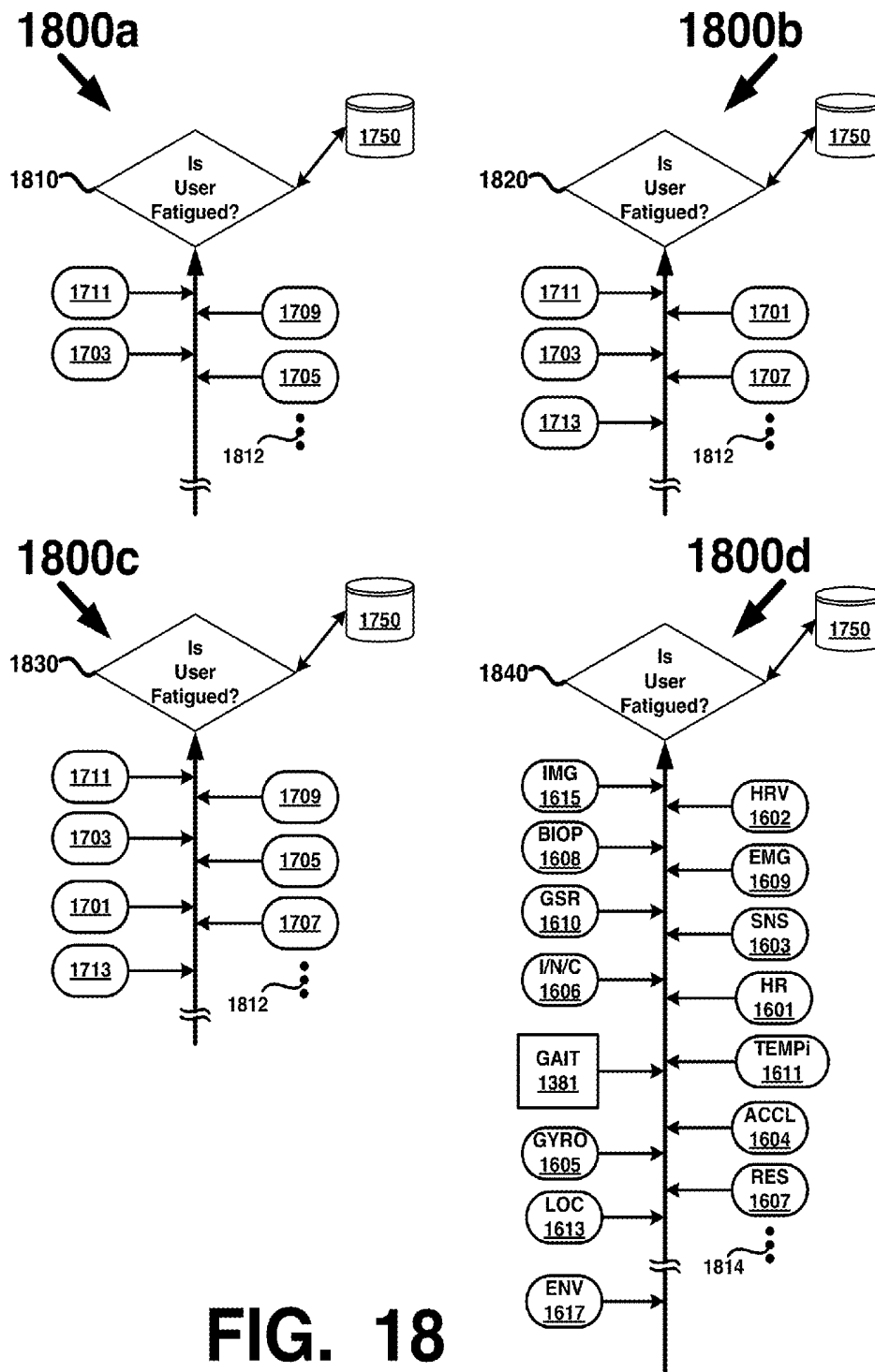
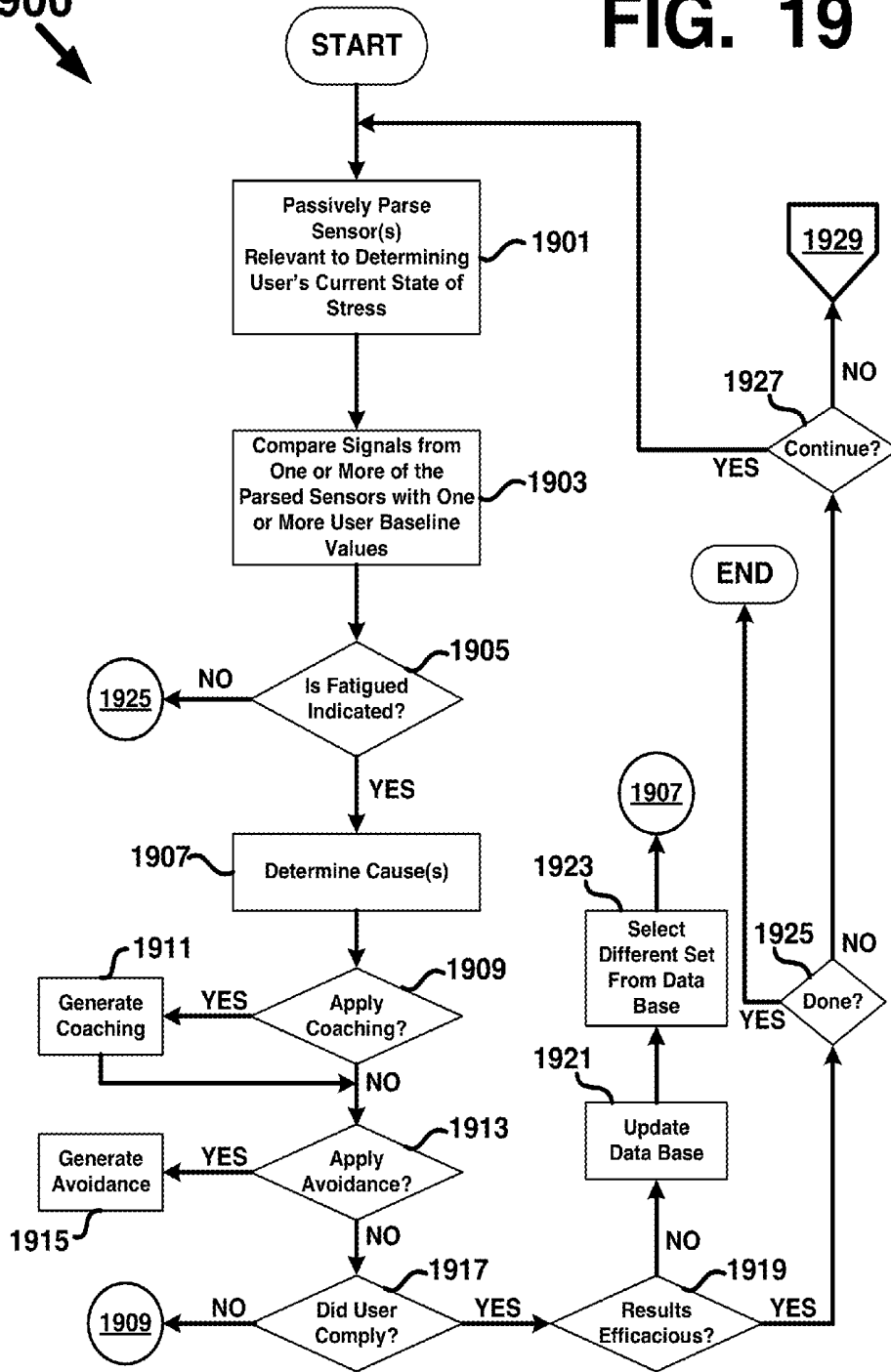

FIG. 18

1900

FIG. 19



## WEARABLE RING FOR SLEEP MONITORING

### CROSS-REFERENCE TO RELATED APPLICATIONS

**[0001]** This Application is a Continuation of Co-Pending U.S. patent application Ser. No. 14/145,856, filed on Dec. 31, 2013, having Attorney Docket No. ALI-282, and titled “Wearable Device To Detect Inflammation”. This Application is also related to the following applications: U.S. patent application Ser. No. 14/073,550, filed on Nov. 6, 2013, having Attorney Docket No. ALI-280, and titled “Protective Covering For Wearable Devices”; U.S. patent application Ser. No. 13/830,860, filed on Mar. 14, 2013, having Attorney Docket No. ALI-152, and titled “Platform For Providing Wellness Assessments And Recommendations Using Sensor Data”; U.S. patent application Ser. No. 13/967,317, filed on Aug. 14, 2013, having Attorney Docket No. ALI-260, and titled “Real-Time Psychological Characteristic Detection Based On Reflected Components Of Light”; and U.S. patent application Ser. No. 13/890,1433, filed on May 8, 2013, having Attorney Docket No. ALI-262, and titled “System And Method For Monitoring The Health Of A User”, all of which are hereby incorporated by reference in their entirety for all purposes.

### FIELD

**[0002]** The present application relates generally to portable electronics, wearable electronics, biometric sensors, personal biometric monitoring systems, location sensing, and more specifically to systems, electronics, structures and methods for wearable devices for inflammation monitoring, contraction monitoring, reporting and health coaching and avoidance for a user.

### BACKGROUND

**[0003]** Systemic inflammation may be a medial indicator, leading indicator or cause of many disease states and ill health known (e.g., genetic disease, communicable disease, the common cold, flu, organ disease, injury, trauma, cancer, etc.). Examples of bodily events that may cause bodily tissues to swell (e.g., capillary dilation, interstitial fluid buildup, etc.) and manifest as inflammation include prolonged stress and sleep deprivation. In the case of sleep deprivation, people often associated a feeling or appearance of puffiness which typically manifests itself around the eyes as bags under the eyes or puffiness of the soft tissues that surround the eyes. Another example is acute inflammation, such as resulting from dosing high levels of sugar due to an insulin response causing blood sugar to be stored in cells and fluid storage in the cells that lead to inflammation. An immune response state of the body (e.g., at the onset of disease or a prolonged disease state) is yet another example of a causation of inflammation. Chronic inflammation may be caused by a bodily system(s) constantly fighting off some prolonged state such as injury to muscles, ligaments, organs and other tissues, and organ disease, for example. Causation of inflammation may be disconnected from or distant the portion(s) of the body where the inflammation manifests itself, as in the case of athletes that over train or injury or organ disease, for example. Systemic inflammation is not typically a localized event and some body event that is the cause of the inflammation will typically be manifested in other areas of the body, such as the fingers of the hands (e.g., any of the digits of the hand including the thumb),

or the toes of the foot, for example. In some examples, body tissues may shrink due to lack of hydration and that shrinkage may be most prominently evident in cases of severe dehydration where slight shrinkages of body tissues may be ascertainable through measurement. One or more biometric indicators may be associated with systemic inflammation and/or dehydration and be measured using a variety of biometric or other types of sensors and systems, such as metrics from electrodermal activity of the skin (e.g., galvanic skin response—GSR, etc.), heart rate monitors, body weight, bio-impedance, body temperature, just to name a few. For example, an increase in skin resistance due to dehydration may be detected using a GSR sensor, and EMG sensor, or other sensors for detecting electrodermal activity.

**[0004]** Moreover, environmental, dietary, social conditions and other externalities may impact bodily functions that cause inflammation, such as stress from work, school, relationships, family members, finances, commuting, etc. Systemic inflammation may be used as a biomarker that may be helpful in diagnosing disease or as an indicator of early onset of disease. Ideally, it would be desirable to accurately distinguish between systemic inflammation caused by some bodily event and/or externalities that effect the body as opposed to swelling of body tissues that may be due to added muscle mass (e.g., cell growth leading to muscle tissue growth) or shrinkage of body tissues due to dehydration.

**[0005]** Accordingly, there is a need for a user wearable device that monitors a plurality of bodily metrics and external data to measure inflammation, indicate inflammation to the user, and optionally provide coaching and/or remediation to the user.

### BRIEF DESCRIPTION OF THE DRAWINGS

**[0006]** Various embodiments or examples (“examples”) of the present application are disclosed in the following detailed description and the accompanying drawings. The drawings are not necessarily to scale:

**[0007]** FIGS. 1A-1B depict a cross-sectional views of examples of wearable devices to detect inflammation coupled with a body portion in different states, a nominal state in FIG. 1A and an inflammation state in FIG. 1B, according to an embodiment of the present application;

**[0008]** FIG. 2 depicts an exemplary computer system, according to an embodiment of the present application;

**[0009]** FIG. 3 depicts a block diagram of one example of a wearable device to detect inflammation, according to an embodiment of the present application;

**[0010]** FIG. 4A depicts cross-sectional views of examples of a portion of the same body in three different dimensional states: a nominal dimension; a contracted dimension; and an inflammation dimension, according to an embodiment of the present application;

**[0011]** FIG. 4B depicts cross-sectional views examples of sensors in a wearable device to detect inflammation in contact with the body portions of FIG. 4A and generating signals, according to an embodiment of the present application;

**[0012]** FIG. 5 depicts a profile view of one example configuration for a wearable device to detect inflammation, according to an embodiment of the present application;

**[0013]** FIGS. 6A-6G depict examples of different configurations for a wearable device to detect inflammation, according to an embodiment of the present application;

**[0014]** FIGS. 7A-7B depict cross-sectional views of examples of different configurations for a wearable device to

detect inflammation and associated sensor systems, according to an embodiment of the present application;

[0015] FIG. 7C depicts cross-sectional views of examples of a wearable device to detect inflammation and a sensor system in three different dimensional states related to a body portion being sensed, according to an embodiment of the present application;

[0016] FIG. 8A depicts a profile view of forces and motions acting on a user having a wearable device to detect inflammation, according to an embodiment of the present application;

[0017] FIG. 8B-8G depicts examples of activities of a user having a wearable device to detect inflammation, according to an embodiment of the present application;

[0018] FIG. 9 depicts a block diagram of sensor systems, data communication systems, data processing systems, wireless client devices, and data systems that may be coupled with and/or in communication with a wearable device to detect inflammation, according to an embodiment of the present application;

[0019] FIG. 10 depicts one example of a flow diagram for measuring, identifying, and remediating inflammation in a wearable device to detect inflammation, according to an embodiment of the present application;

[0020] FIG. 11 depicts a block diagram of an example of a system including one or more wearable devices to detect inflammation, according to an embodiment of the present application;

[0021] FIG. 12A depicts a profile view of one example of a wearable device to detect inflammation, according to an embodiment of the present application;

[0022] FIG. 12B depicts a cross-sectional view of one example of components in a wearable device to detect inflammation, according to an embodiment of the present application;

[0023] FIG. 12C depicts another profile view of another example of a wearable device to detect inflammation, according to an embodiment of the present application;

[0024] FIG. 13 depicts a block diagram of an example of a cycle of monitoring a user having a wearable device to detect inflammation and data inputs that may be used in a calculus for determining whether or not inflammation, contraction, or nominal states are indicated in the user, according to an embodiment of the present application;

[0025] FIG. 14 depicts one example of a flow diagram for passively determining a true resting heart rate (TRHR) of a user, according to an embodiment of the present application;

[0026] FIGS. 15A-15B depict two different examples of sensed data that may be relevant to passively determining a true resting heart rate (TRHR) of a user, according to an embodiment of the present application;

[0027] FIG. 16 depicts a block diagram of non-limiting examples of relevant sensor signals that may be parsed, read, scanned, and/or analyzed for passively determining a true resting heart rate (TRHR) of a user, according to an embodiment of the present application;

[0028] FIG. 17A depicts a block diagram of one example of sensor platform in a wearable device to passively detect fatigue of a user that includes a suite of sensors, according to an embodiment of the present application;

[0029] FIG. 17B depicts one example of a wearable device to passively detect fatigue of a user, according to an embodiment of the present application;

[0030] FIG. 17C depicts one example of speed of movement and heart rate as indicators of fatigue captured by sensors in communication with a wearable device to passively detect fatigue of a user, according to an embodiment of the present application;

[0031] FIG. 18 depicts examples of sensor inputs and/or data that may be sourced internally or externally in a wearable device to passively detect fatigue of a user, according to an embodiment of the present application; and

[0032] FIG. 19 depicts one example of a flow diagram for passively detecting fatigue in a user, according to an embodiment of the present application.

#### DETAILED DESCRIPTION

[0033] Various embodiments or examples may be implemented in numerous ways, including as a system, a process, an apparatus, a user interface, or a series of program instructions on a non-transitory computer readable medium such as a computer readable storage medium or a computer network where the program instructions are sent over optical, electronic, or wireless communication links. In general, operations of disclosed processes may be performed in an arbitrary order, unless otherwise provided in the claims.

[0034] A detailed description of one or more examples is provided below along with accompanying drawing FIGS. The detailed description is provided in connection with such examples, but is not limited to any particular example. The scope is limited only by the claims and numerous alternatives, modifications, and equivalents are encompassed. Numerous specific details are set forth in the following description in order to provide a thorough understanding. These details are provided for the purpose of example and the described techniques may be practiced according to the claims without some or all of these specific details. For clarity, technical material that is known in the technical fields related to the examples has not been described in detail to avoid unnecessarily obscuring the description.

[0035] Reference is now made to FIGS. 1A-1B where cross-sectional views of examples of wearable devices to detect inflammation 100 (device 100 hereinafter) are coupled with a body portion in different states as will be described below. In FIGS. 1A-1B device 100 may include one or more sensors 110 for detecting/sensing force, pressure, or other metric associated with tissues of a body indicative of inflammation and/or contraction, for example. In that pressure may be defined a force per unit of area, hereinafter, the term force F will be used to describe the unit sensed by sensors 110 although one skilled in the art will understand that pressure or other metric may be interchangeably used in place of force F. Sensors 110 generate one or more signals S indicative of force acting on them via a coupling or contact with a body portion 101 of a user, such as a portion of an empennage, neck, torso, wrist, ankle, waist, or other area or portion of a body. In some examples, the body portion being sensed by sensors 110 is of a human body. In other examples, the body portion being sensed by sensors 110 is of a non-human body. For purposes of further explanation, a human body (e.g., of a user 800) will be used as a non-limiting example. Body portion 101 may comprise body tissue or tissues on a portion of a user body, such as the arms, legs, torso, neck, abdomen, etc. Sensors may be used to sense activity (e.g., biometric activity and related electrical signals) within the body tissue (e.g., body portion 101) or on a surface of the body tissue (e.g., a skin surface of body portion 101).

[0036] Device 100 may include other sensors for sensing environmental data, biometric data, motion data that may include little or no motion as in awake and resting or sleeping, just to name a few. Device 100 and some or all of its components may be positioned in a chassis 102 configured to be worn, donned, or otherwise connected with a portion of a user's body and configured to either directly contact some or all of the portion or to be positioned in close proximity to the portion. Device 100 may include a RF system 150 for wireless communication (152, 154, 153, 155) with external wireless systems using one or more radios which may be RF receivers, RF transmitters, or RF transceivers and those radios may use one or more wireless protocols (e.g., Bluetooth, Bluetooth Low Energy, NFC, WiFi, Cellular, broadband, one or more varieties of IEEE 802.11, etc.). Device 100 may include a user interface 120 such as a display (e.g., LED, OLED, LCD, touch screen or the like) or audio/video indicator system (e.g., speaker, microphone, vibration engine, etc.). As systemic inflammation may be a good to excellent indicator of a user's mood, device 100 may serve as a "mood ring" for a user's body. The display or one or more LED's (e.g., color LED's or RGB LED's) may be used to indicate mood as function of indication of inflammation, contraction, or nominal and those indications may be coupled with other biometric sensor readings (e.g., heart rate, heart rate variability, respiration, GSR, EMG, blood pressure, etc.) to indicate mood using one or more combinations of color, sound, or graphics/images presented on the display. In some examples, the user's mood may be displayed or otherwise presented for dissemination by the user, on an external device, such as a wireless client device (e.g., 680, 690, 999), the device 100 or both.

[0037] Device 100 may include a bus 111 or other electrically conductive structure for electrically communicating signals from sensors 110, other sensors, processor(s), data storage, I/O systems, power systems, communications interface, etc. Bus 111 may electrically couple other systems in device 100 such as power source 130 (e.g., a rechargeable battery), biometric sensors 140 (heart rate, body temperature, bioimpedance, respiration, blood oxygen, etc.), sensors of electrodermal activity on or below the skin (e.g., skin conductance, galvanic skin response—GSR, sensors that sense electrical activity of the sympathetic nervous system on the skin and/or below the skin, skin conductance response, electrodermal response, etc.), sensors that sense arousal, sensors for detecting activity of the sympathetic nervous system, electromyography (EMG) sensors, motion sensors 160 (e.g., single or multi-axis accelerometer, gyroscope, piezoelectric device), a compute engine (not shown, e.g., single-core or multiple-core processor, controller, DSP, ASIC, SoC, base-band processor,  $\mu$ P,  $\mu$ C, etc.), and data storage (not shown, e.g., Flash Memory, ROM, SRAM, DRAM, etc.).

[0038] Chassis 102 may have any configuration necessary for coupling with and sensing the body portion 101 of interest and chassis 102 may include an esthetic element (e.g., like jewelry) to appeal to fashion concerns, fads, vanity, or the like. Chassis 102 may be configured as a ring, ear ring, necklace, jewelry, arm band, head band, bracelet, cuff, leg band, watch, belt, sash, or other structure that may be worn or otherwise coupled with the body portion 101. Chassis 102 may include functional elements such as location of buttons, switches, actuators, indicators, displays, A/V devices, waterproofing, water resistance, vibration/impact resistance, just to name a few.

[0039] In FIGS. 1A-1B, device 100 is depicted in cross-sectional view and having an interior portion 102i in contact with the body portion 101 to be sensed by device 100 (e.g., sensed for inflammation, contraction, nominal state, or other). In FIG. 1A, the body portion 101 is depicted in a nominal state in which the body is not experiencing systemic inflammation or contraction (e.g., due to dehydration or other causation). In the nominal state, body portion 101 has nominal dimensions in various direction denoted as  $D_0$  and a force  $F_0$  indicative of the nominal state acts on sensors 101 which generate signal(s) indicative of the nominal state denoted as  $S_0$ . As will be described in greater detail below, state such as the nominal state, the contraction state, and the inflammation state may not be instantaneously determined in some examples, and those states may be determined and re-determined over time (e.g., minutes, hours, days, weeks, months) and in conjunction with other data inputs from different sources that may also be collected and or disseminated over time (e.g., minutes, hours, days, weeks, months).

[0040] In FIG. 1A, signals  $S_0$  indicative of the nominal state (e.g., fluids in tissues of the user are not generating forces on sensors 101 indicative of inflammation and/or contraction) are electrically coupled over bus 111 to other systems of device 100 for analysis, processing, calculation, communication, etc. For example, data from signals  $S_0$  may be wirelessly communicated (154, 152) to an external resource 199 (e.g., the Cloud, the Internet, a web page, web site, compute engine, data storage, etc.) and that data may be processed and/or stored with other data external to device 100, internal to device 100 (e.g., other sensors such as biometric sensors, motion sensors, location data) or both. Resource 199 may be in data communication (198, 196) with other systems and devices 100, using wired and/or wireless communications links. The determination that the state of the user is one that is the nominal state may not be an immediate determination and may require analysis and re-computation over time to arrive at a determination that one or more of  $D_0$ ,  $F_0$  or  $S_0$  are indicative of the nominal state and the user is not experiencing systemic inflammation or contraction. Here, dimension  $D_0$  may have variations in its actual dimension over time as denoted by dashed arrows 117. For example, due to changes in user data, environment, diet, stress, etc., a value for  $D_0$  today may not be the same as the value for  $D_0$  two months from today. As variation 117 may apply to the dimensions associated with contraction and inflammation as will be described below, that is, the dimensions may not be static and change over time as the user undergoes changes that are internal and/or external to the body.

[0041] In FIG. 1B, body portion 101 is depicted in an inflammation state where a dimension  $D_i$  is indicative of systemic inflammation (e.g., increased pressure of fluids in tissues/cells of the user's body) and an inflammation force  $F_i$  acts on sensors 110 to generate signal(s)  $S_i$  and those signals may be electrically coupled over bus 111 to other systems of device 100 for analysis, processing, calculation, communication, etc. For example, data from signals  $S_i$  may be wirelessly communicated (154, 152) to an external resource 199 as was described above in reference to FIG. 1A.

[0042] In FIGS. 1A-1B, chassis 102 of device 100 is depicted as having substantially smooth inner surfaces that contact the body portion 101 and completely encircling the body portion 101. However, actual shapes and configurations for chassis 102 may be application dependent (e.g., may depend on the body part the chassis 102 is to be mounted on)

and are not limited to the examples depicted herein. Device **100a** depicts an alternate example, where chassis **102** includes an opening or gap denoted as **102g** and sensors **110** are positioned at a plurality of locations along the chassis **102** and other sensors denoted as **110g** are positioned in the gap **102g**. Here, as body part undergoes inflammation and its tissues expand, some of the expanded tissue may move into the gap **102g** and exert force  $F_i$  on sensors **110g** and that force may be different (e.g., in magnitude) than the force  $F_i$  exerted on sensors **110** along chassis **102**. Accordingly, signals  $S_i$  from sensors **110g** and **110** may be different (e.g., in magnitude, waveform, voltage, current, etc.) and that difference may be used in the calculus for determining the inflammation state. Conversely, when body part is in the nominal state and/or contraction state, then portions of body part may not extend into the gap **102g** and/or exert less  $F_i$  on sensors **110g** than on sensors **110** and that difference (e.g., in the signals  $S_i$  from sensors **110g** and **110**) may be used in the calculus for determining which state the user is in (e.g., nominal, contraction, or inflammation).

[0043] Device **100b** depicts another alternate example, where chassis **102** includes along its interior portions that contact the body portion, one or more recessed or concave sensors **110cc** and one or more protruding or convex sensors **110cv**, and optionally one or more sensors **110**. Here, when body portion **101** is undergoing inflammation, sensors **110cv** may experience a higher  $F_i$  due to its protruding/convex shape creating a high pressure point with the tissues urged into contact with it due to the inflammation. Sensors **110cc** may experience a lower  $F_i$  due to its recessed/concave shape creating a low pressure point with the tissues urged into contact with it due to the inflammation and/or those tissues not expanding into any or some of a volume created by the recessed/concave shape. Sensors **110** may experience a force  $F_i$  that is in between that of sensors **110cv** and **110cc**. Accordingly, differences in signals  $S_i$  from one or more of the sensors **110**, **110cv**, and **110cc** may be processed and used in the calculus for determining which state the user is in as described above. Similarly, if body portion **101** is in the contraction state, sensors **110cc** may experience little or no force  $F_i$  because tissue may not contact their sensing surfaces, sensors **110cv** may experience a force  $F_i$  that is greater than the force  $F_i$  experience by sensors **110** and the signals  $S_i$  representative of those differences in force  $F_i$  may be processed as described above to determine the users state. On the other hand, if body portion **101** is in the nominal state, sensors **110cc** may experience little or no force  $F_i$  because tissue may not contact their sensing surfaces, sensors **110cv** may experience a force  $F_i$  that is greater than the force  $F_i$  experience by sensors **110** and the signals  $S_i$  representative of those differences in force  $F_i$  may be processed as described above to determine the users state. The processing along with other data inputs may be used to determine if the signals  $S_i$  are more indicative of the contraction state or the nominal state, as those states may have similar characteristics for signals  $S_i$ . Alternate chassis and sensor **110** locations will be described in greater detail below in regards to FIGS. 6A-6G. Shapes for sensors **110cv** and/or **110cc** may be formed by slots, grooves, ridges, undulations, crenulations, dimples, bumps, domes (inward and/outward facing), gaps, spacing's, channels, canals, or other structures and are not limited to the structures depicted herein.

[0044] FIG. 2 depicts an exemplary computer system **200** suitable for use in the systems, methods, and apparatus

described herein. In some examples, computer system **200** may be used to implement circuitry, computer programs, applications (e.g., APP's), configurations (e.g., CFG's), methods, processes, or other hardware and/or software to perform the above-described techniques. Computer system **200** includes a bus **202** or other communication mechanism for communicating information, which interconnects sub-systems and devices, such as one or more processors **204**, system memory **206** (e.g., RAM, SRAM, DRAM, Flash), storage device **208** (e.g., Flash Memory, ROM), disk drive **210** (e.g., magnetic, optical, solid state), communication interface **212** (e.g., modem, Ethernet, one or more varieties of IEEE 802.11, WiFi, WiMAX, WiFi Direct, Bluetooth, Bluetooth Low Energy, NFC, Ad Hoc WiFi, HackRF, USB-powered software-defined radio (SDR), WAN or other), display **214** (e.g., CRT, LCD, OLED, touch screen), one or more input devices **216** (e.g., keyboard, stylus, touch screen display), cursor control **218** (e.g., mouse, trackball, stylus), one or more peripherals **240**. Some of the elements depicted in computer system **200** may be optional, such as elements **214-218** and **240**, for example and computer system **200** need not include all of the elements depicted.

[0045] According to some examples, computer system **200** performs specific operations by processor **204** executing one or more sequences of one or more instructions stored in system memory **206**. Such instructions may be read into system memory **206** from another non-transitory computer readable medium, such as storage device **208** or disk drive **210** (e.g., a HD or SSD). In some examples, circuitry may be used in place of or in combination with software instructions for implementation. The term "non-transitory computer readable medium" refers to any tangible medium that participates in providing instructions to processor **204** for execution. Such a medium may take many forms, including but not limited to, non-volatile media and volatile media. Non-volatile media includes, for example, Flash Memory, optical, magnetic, or solid state disks, such as disk drive **210**. Volatile media includes dynamic memory (e.g., DRAM), such as system memory **206**. Common forms of non-transitory computer readable media includes, for example, floppy disk, flexible disk, hard disk, Flash Memory, SSD, magnetic tape, any other magnetic medium, CD-ROM, DVD-ROM, Blu-Ray ROM, USB thumb drive, SD Card, any other optical medium, punch cards, paper tape, any other physical medium with patterns of holes, RAM, PROM, EPROM, FLASH-EPROM, any other memory chip or cartridge, or any other medium from which a computer may read.

[0046] Instructions may further be transmitted or received using a transmission medium. The term "transmission medium" may include any tangible or intangible medium that is capable of storing, encoding or carrying instructions for execution by the machine, and includes digital or analog communications signals or other intangible medium to facilitate communication of such instructions. Transmission media includes coaxial cables, copper wire, and fiber optics, including wires that comprise bus **202** for transmitting a computer data signal. In some examples, execution of the sequences of instructions may be performed by a single computer system **200**. According to some examples, two or more computer systems **200** coupled by communication link **220** (e.g., LAN, Ethernet, PSTN, wireless network, WiFi, WiMAX, Bluetooth (BT), NFC, Ad Hoc WiFi, HackRF, USB-powered software-defined radio (SDR), or other) may perform the sequence of instructions in coordination with one another. Computer sys-

tem **200** may transmit and receive messages, data, and instructions, including programs, (e.g., application code), through communication link **220** and communication interface **212**. Received program code may be executed by processor **204** as it is received, and/or stored in a drive unit **210** (e.g., a SSD or HD) or other non-volatile storage for later execution. Computer system **200** may optionally include one or more wireless systems **213** in communication with the communication interface **212** and coupled (**215**, **223**) with one or more antennas (**217**, **225**) for receiving and/or transmitting RF signals (**221**, **227**), such as from a WiFi network, BT radio, or other wireless network and/or wireless devices, for example. Examples of wireless devices include but are not limited to: a data capable strap band, wristband, wristwatch, digital watch, or wireless activity monitoring and reporting device; a smartphone; cellular phone; tablet; tablet computer; pad device (e.g., an iPad); touch screen device; touch screen computer; laptop computer; personal computer; server; personal digital assistant (PDA); portable gaming device; a mobile electronic device; and a wireless media device, just to name a few. Computer system **200** in part or whole may be used to implement one or more systems, devices, or methods that communicate with transponder **100** via RF signals (e.g., RF System **135**) or a hard wired connection (e.g., data port **138**). For example, a radio (e.g., a RF receiver) in wireless system(s) **213** may receive transmitted RF signals (e.g., **154**, **152**, **153**, **155** or other RF signals) from wearable device **100** that include one or more datum (e.g., sensor system information) related to nominal state, inflammation, contraction, temperature, temporal data, biometric data, forces, motion, or other events in a user's body. Computer system **200** in part or whole may be used to implement a remote server or other compute engine in communication with systems, devices, or method for use with the transponder **100** as described herein. Computer system **200** in part or whole may be included in a portable device such as a smartphone, tablet, or pad. The portable device may be carried by an emergency responder or medical professional who may use the datum transmitted Tx **132** by transponder **100** and received and presented by the computer system **200** to aid in treating or otherwise assisting the user wearing the transponder **100**.

[0047] Turning now to FIG. 3 where a block diagram of one example **300** of a wearable device to detect inflammation **100** is depicted. In example **300**, device **100** may include but is not limited to having one or more processors, a data storage unit **320**, a communications interface **330**, a sensor system **340**, a power system **350**, an input/output (I/O) system **360**, and an environmental sensor **370**. The foregoing are non-limiting examples of what may be included in device **100** and device **100** may include more, fewer, other, or different systems than depicted. The systems of device **100** may be in communication (**311**, **321**, **331**, **341**, **351**, **352**, **361**, **371**) with a bus **301** or some other electrically conductive structure. In some examples, one or more systems of device **100** may include wireless communication of data and/or signals to one or more other systems of device **100** or another device **100** that is wirelessly linked with device **100** (e.g., via communications interface **330**).

[0048] The various systems may be electrically coupled with a bus **301** (e.g., see bus **111** in FIGS. 1A-1B). Sensor system **340** may include one or more sensors that may be configured to sense **345** an environment **399** external **346** to chassis **102** such as temperature, sound, light, atmosphere, etc. In some examples, one or more sensors for sensing envi-

ronment **399** may be included in the environmental system **370**, such as a sensor **373** for sound (e.g., a microphone or other acoustic transducer), a light sensor **375** (e.g., an ambient light sensor, an optoelectronic device, a photo diode, PIN diode, photo cell, photo-sensitive device **1283** of FIG. 13, etc.), and an atmospheric sensor **378** (e.g., a solid state, a semiconductor, or a metal oxide sensor). Sensor system **340** may include one or more sensors for sensing **347** a user **800** that is connected with or otherwise coupled **800i** with device **100** (e.g., via a portion of chassis **102**) and those sensors may include the aforementioned biometric and other sensors. Sensor system **340** includes one or more of the sensors **110**, **110cv**, **110cc** for generating the signals  $S_0$ ,  $S_s$ ,  $S_C$  as described above. Signals from other sensors in sensor system **340** are generically denoted as  $S_n$  and there may be more signals  $S_n$  than depicted as denoted by **342**. Processor(s) **301** may include one or more of the compute engines as described above (e.g., single-core or multiple-core processor, controller, DSP, ASIC, SoC, baseband processor,  $\mu P$ ,  $\mu P$ , etc.). Computation, analysis or other compute functions associated with signals from sensor system **340** may occur in processor **310**, external to device **100** (e.g., in resource **199**) or both. Data and results from external computation/processing may be communicated to/from device **100** using communications interface **330** via wireless **196** or wired **339** communications links. Sensor system **340** may include one or more motion sensors (e.g., single-axis or multi-axis accelerometers, gyroscopes, vibration detectors, piezoelectric devices, etc.) that generate one or more of the signals  $S_n$  and those signals  $S_n$  may be generated by motion and/or lack of motion (e.g., running, exercise, sleep, rest, eating, etc.) of the user **800**, such as translation (Tx, Ty, Tz) and/or rotation (Rx, Ry, Rz) about an X-Y-Z axes **897** of the users body during day-to-day activities. In some examples, the motion signals  $S_n$  may be from sensors external to device **100** (e.g., from other devices **100**, fitness monitors, data capable strap bands, exercise equipment, smart watches or other wireless systems), internal to device **100** or both.

[0049] Data storage unit **320** may include one or more operating systems (OS), boot code, BIOS, algorithms, data, user data, tables, data structures, applications (APP) or configurations (CFG) denoted as **322-326** that may be embodied in a non-transitory computer readable medium (NTRM) that may be configured to execute on processor **310**, an external processor/compute engine (e.g., resource **199**) or both. There may be more or fewer elements in data storage unit **320** (DS **320** hereinafter) as denoted by **329**. As one example, DS **320** may comprise non-volatile memory, such as Flash memory. CFG **125** may be a configuration file used for configuring device **100** to communicate with wireless client devices, other devices **100**, with wireless access points (AP's), resource **199**, and other external systems. Moreover, CFG **125** may execute on processor **310** and include executable code and/or data for one or more functions of device **100**. CFG **125** may include data for establishing wireless communications links with external wireless devices using one or more protocols including but not limited to Bluetooth, IEEE 802.11, NFC, Ad Hoc WiFi, just to name a few, for example.

[0050] Communications interface **330** may include a RF system **335** coupled with one or more radios **332**, **336** for wireless **196** communications, an external communications port **338** for wired communications with external systems. Port **338** may comprise a standard interface (e.g., USB, HDMI, Lightning, Ethernet, RJ-45, TRS, TRRS, etc.) or pro-

proprietary interface. Communications interface **330** may include a location/GPS unit for determining location of the device **100** (e.g., as worn by the user **800**) and/or for gathering location/GPS data from an external source or both. The one or more radios **332**, **336** may communicate using different wireless protocols. There may be more or fewer radios and/or systems in RF system **335** as denoted by **331**.

[0051] Power system **350** may supply electrical power at whatever voltages and current demands required by systems of device **100** using circuitry and/or algorithms for power conditioning, power management, power regulation, power savings, power standby, etc. One or more power sources **355** may be coupled with power system **350**, such as rechargeable batteries (e.g., Lithium Ion or the like), for example.

[0052] I/O system **360** may include one or more hardware and/or software elements denoted as **362-368** of which there may be more or fewer than depicted as denoted by **365**. Those elements may include but are not limited to a display or other user interface (e.g., **120** of FIGS. 1A-1B), a microphone, a speaker, a vibration engine (e.g., a buzzer or the like), indicator lights (e.g., LED's), just to name a few. I/O system **360** may communicate data to/from the communications interface **330** to other systems in device **100** (e.g., via bus **301** or **111**), for example. An image capture device **369** may be included in I/O system **360**, sensor system **340** or both. Image capture device **369** (e.g., video or still images) may be used to image **369i** facial expressions and/or micro-expressions on a face **815** of a user **800**. Image capture device **369** (e.g., video or still images) may be used to image **369i** a posture of the user **800**'s body (e.g., see **369** and **369i** in FIG. 8A). Hardware and/or software may be used to process captured image **369i** data and generate an output signal that may be used in determining fatigue, stress, systemic inflammation, contraction, or other conditions of user **800**'s emotional, mental or physical state. Signals from image capture device **369** may be treated as one form of sensor signal, regardless of the system in device **100** that the image capture device is positioned in or associated with.

[0053] As a person skilled in the art will recognize from the previous detailed description and from the drawing FIGS. and claims set forth below, modifications and changes may be made to the embodiments of the present application without departing from the scope of this present application as defined in the following claims.

[0054] [0054] Moving on to FIG. 4A where cross-sectional views of examples **400a** of a portion of the same body in three different dimensional states comprised of a nominal dimension **101n**, a contracted dimension **101c**, and an inflammation dimension **101i** are depicted. For purposes of explanation, assume that the body portion depicted is resting on a flat and rigid surface **410**, such as a table top or the like such that a distance from a top **410s** of the surface **410** to a top **101s** of the body portions in the different states (**101n**, **101c**, **101i**) may be accurately measured. In order of Time from the left of the drawing sheet to the right of the drawing sheet, at a time interval  $t_a$ , a dimension  $D_0$  (e.g., height or thickness from **410s** to **101s**) of the nominal body **101n** is measured, and subsequent measurements taken at later time intervals  $t_b$  and  $t_c$  yield dimensions of  $D_c$  and  $D_i$  respectively for contracted body portion **101c** and inflamed body portion **101i** respectively. Here,  $D_c < D_0 < D_i$ . Over the different time intervals ( $t_a$ ,  $t_b$ ,  $t_c$ ) the dimensions of the body portion changed as conditions internal to and/or external to the users body changed. These changes in dimension may continuously vary over

Time with the dimensions sometimes being nominal, sometimes being contracted, and sometimes being inflamed.

[0055] Referring now to FIG. 4B were cross-sectional views examples **400b** of sensors **110** in a wearable device to detect inflammation **100** in contact **102i** with the body portions of FIG. 4A and generating signals indicative of the aforementioned dimensions of the body portions in different states (**101n**, **101c**, **101i**). During time interval  $t_a$ , a dimension  $D_0$  exerts a force  $F_0$  on sensor **110** which generates a signal  $S_0$  indicative of the nominal state for body portion **101n** during time interval  $t_a$ . Similarly, later time intervals  $t_b$  and  $t_c$  yield dimensions of  $D_c$  and  $D_i$ , exerted forces  $F_c$  and  $F_i$ , and generated signals  $S_c$  and  $S_i$  respectively for contracted body portion **101c** and inflamed body portion **101i** during those intervals of Time. Here,  $D_c < D_0 < D_i$  and  $F_c < F_0 < F_i$ . The differences in waveform shapes for the generated signals  $S_n$ ,  $S_c$  and  $S_i$  are only for purposes of illustration and actual waveforms may be different than depicted. Generated signals  $S_n$ ,  $S_c$  and  $S_i$  may or may not follow the relationship  $S_c < S_0 < S_i$  and actual signal magnitudes may be application dependent and may not be linear or proportional to force exerted on sensors **110** by the body portions depicted. In FIG. 4B, the dimension may continuously vary over Time with the dimensions sometimes being nominal, sometimes being contracted, and sometimes being inflamed as was described above. As the nominal, contracted, and inflamed dimensions change with Time, device **100** and/or other devices in communication with device **100** may repeatedly update and retrieve signal data or other data associated with the states from a source such as DS **320** and/or an external resource (e.g., **199**). For this example **400b**, the signal and/or other data for the three states may be repeatedly updated, stored, retrieved or otherwise accessed from resource **199** as denoted by dashed arrows **460-462** for nominal state related data **450**, contracted state related data **451**, and inflamed state related data **452**. The aforementioned changes in dimension over Time are repeatedly sensed and compared with other data to calculate the actual state of the user (i.e., nominal, contracted, inflammation). Therefore an instantaneous or sudden change in any one of the signals ( $S_n$ ,  $S_c$  and  $S_i$ ) from sensors **110** does not automatically indicate an accurate determination of state in the absence of other information and data used in the calculus for determining state. Resource **199** may include additional data as denoted by **469** and that data, as will be described above, may be used along with the signal data to calculate state.

[0056] Moving on to FIG. 5 where a profile view of one example **500** of a configuration for a wearable device to detect inflammation **100** may include a watch band, strap or the like as part of chassis **102**, a buckle **511**, tongue **513**, loops **515**, and a user interface **120** that may include buttons **512** and **514**, a display **501**, a port **338** for wired communication links (e.g., **198**) and/or charging an internal power source such as a rechargeable battery, and a RF system for wireless **196** communications (e.g., with resource **199** or other devices **100**). Device **100** may include a plurality of the sensors **110** disposed at various positions about the strap **102** and user interface **120** as denoted in dashed outline. Upon donning the device **100**, a user may set baseline tension or tightness of the device **100** (e.g., about a wrist) such that one or more portions of the users body are coupled or otherwise connected with the sensors **110**. In that motion of the user, the device **100**, the tension of strap **102** and other factors may change a magnitude of the force ( $F_c$ ,  $F_0$ ,  $F_i$ ) exerted by body tissues against the sensors **110**, the above mentioned repeated measurements

may be used to arrive at correct states over time when used with other data as described above. As will be described in greater detail below, device **100** may include one or more indicators **561** that may be used to visually display a mood of the user (e.g., of the user's body), as denoted by mood indicators **560**. One or more indicator devices such as a LED may be used for indicator **561**, for example. Alternatively or in addition to mood indicators **560**, display **501** may include a GUI or other form of information presentation that includes a graphic or icon displaying the user mood, such as mood indicator **562** which is depicted as a plurality of black bars **563**, where more bars **563** may indicate a better mood than fewer bars **563**. Similarly, a better mood may be indicated by more of the indicators **561** lighting up than fewer indicators **561** lighting up.

**[0057]** FIGS. 6A-6G depict additional examples of different configurations for a wearable device to detect inflammation **100**. In FIGS. 6A and 6G, device **100** may be configured as a ring to be worn on one of the digits of a hand (e.g., fingers or thumb) of a user or optionally on one of the toes of a foot of the user. Swelling of the tissues of the hand, the fingers of the toes are typical when systemic inflammation occurs (e.g., a feeling of puffiness in the hands/fingers) and those body portions may be ideal locations to position device **100** for measuring inflammation. In examples **600a1** and **601a2** of FIG. 6A, device **100** is configured to have one or more grooves or spirals denoted as **612**. Sensors **110** are disposed at a plurality of locations as depicted in dashed line; however, sensors **110g** are disposed at **612** so that tissue from the fingers that expand outward during inflammation may enter into the groove/spiral **612** and exert force (e.g.,  $F_i$ ) on sensors **110g**. Sensors **110g** may measure force as described above or some other metric such as capacitance or GSR, for example. In example **600a3**, device **100** includes a plurality of dimples similar to the sensors **110cv** and **110cc** of FIG. 1B positioned at an interior portion (e.g., **102i**) of chassis **102** as denoted by dashed regions **614**. The dimples may be concave, convex or both. Depending on the state of the body, dimples that are concave may experience a different force than dimples that are convex and signals from those concave and convex dimples may be used to determine the aforementioned states.

**[0058]** In FIG. 6G, device **100** has a chassis configured as a ring. Here, chassis **102** includes a rigid structure **671** and a deformable structure **673**, and sensors **110** are disposed at various locations within the deformable structure **673**. As the body portion the ring is positioned on, expands and contracts due to tissue fluids etc. (e.g.,  $D_c, D_o, D_i$ ), the deformable structure **673** is compressed upon expansion of the tissue and relaxed upon contraction of the tissues. Forces imparted to the deformable structure **673** by the expansion or contraction may be mechanically coupled with the sensors **110** to generate the signals ( $S_c, S_o, S_i$ ) from the exerted forces ( $F_c, F_o, F_i$ ).

**[0059]** In FIG. 6B, device **100** may be configured to have a chassis **102** formed as a band that may be worn on a wrist or ankle of a user, for example. Band **102** may lack a buckle or other fastening structure such as that depicted in FIG. 5 and may instead be made of semi-flexible materials that retain their shape after being wrapped around the body portion to be sensed (e.g., the wrist or ankle). Sensors **110** may be positioned at locations along band **102** where tissue contact (e.g., **101**) may be most effectively coupled with the sensors **110**. Devices **100** in FIGS. 6B-6F, may optionally include a display **601**.

**[0060]** In FIG. 6C, device **100** includes a chassis **102** that may be configured as a bracelet or armband, for example. Band **102** includes an opening **604** which may be used to ease insertion and removal of the body portion (e.g., an arm or ankle) to be sensed by sensors **110** that are disposed at various locations on an interior portion of band **102**. Sensors **110e** may be positioned at opposing edges of opening **604** and may be configured to sense forces from tissue that expands into the opening **604** due to inflammation as was describe above in reference to FIG. 6A.

**[0061]** In FIGS. 6D-6F, device **100** may be configured as a band (**600d**) or waist band or chest band (**600e, 600f**). In FIGS. 6D and 6E, device **100** may be wirelessly linked **196** (e.g., via WiFi or Bluetooth) with a client device (**680, 690**) that includes an application (APP **651, APP 661**) which may be presented on display **601** in the form of a graphical users interface (GUI) through which a user may configure, control, query, command, and perform other operations on device **100**. Client device (**680, 690**) may replace or work in conjunction with resource **199** and/or device **100** to analyze, process, and calculate the states as described above.

**[0062]** The depictions in FIGS. 6A-6G are non-limiting example of devices **100** and other configurations are possible. The devices **100** depicted in FIGS. 6A-6G may all have wireless communication links, wired links or both. In other examples, a user may wear one or more of the devices **100** depicted in FIGS. 6A-6G or elsewhere as described herein, and those devices **100** may be in wireless communication with one another and with resource **199** or other external sources or systems. Data (e.g., from sensor system **340**) may be collected and wirelessly transmitted by a plurality of the devices **100** and one or more of those devices **100** may process, analyze, calculate or perform other operations on that data either individually, with an external system (e.g., **199** or other) or both.

**[0063]** Turning now to FIGS. 7A-7B where cross-sectional views of examples **700a** and **700b** of different configurations for a wearable device to detect inflammation **100** and associated sensor systems **710** are depicted. In FIG. 7A, chassis **102** includes an opening **720** and a sensor **710** positioned in the opening and coupled with chassis **102**. A body portion **101** having a dimension  $D_M$  (e.g., some diameter of a finger, wrist, ankle, etc.) may be inserted into an interior portion of chassis **102** and in contact with interior surfaces of the chassis **102**. Expansion and/or contraction of the body portion **101** generate the aforementioned forces that may cause the chassis **102** to expand primarily at the opening **720** in response to forces caused by expansion of the body portion **101**, or cause the chassis **102** to contract primarily at the opening **720** in response to forces caused by contraction of the body portion **101** as denoted by dashed arrow **117**. Sensor **710** may generate a signal indicative of expansion, contraction, or nominal status based on forces acting on the sensor **710** or on some other metric sensed by sensor **710**. Sensor **710** may include but is not limited to a strain gauge, a piezoelectric device, a capacitive device, a resistive device, or an inductive device. As one example, as a piezoelectric device, sensor **710** may generate a signal of a first magnitude and/or waveform when forces generated by expansion of body portion **101** causes the opening to expand outward and imparting stress or strain (e.g., tension or stretching) to the piezoelectric device causing the signal  $S_i$  to be generated. On the other hand, sensor **710** may generate a signal of a second magnitude and/or waveform when forces generated by contraction of body portion

**101** causes the opening to contract inward and imparting stress or strain (e.g., compression, squeezing, or deformation) to the piezoelectric device causing the signal  $S_C$  to be generated. Sensor **710** may generate the nominal signal  $S_n$  when forces acting on it over time generate signals that are within a range of values not indicative of inflammation (e.g., expansion of opening **720**) or of dehydration or other (e.g., contraction of opening **720**). In other examples, sensor **710** may be a variable capacitance-based, variable resistance-based, or variable inductance-based device that changes its capacitance, resistance or inductance in response to being stretched or compressed.

**[0064]** In FIG. 7B, chassis **102** includes a plurality of openings (**730**, **740**) and sensors (**750**, **760**) positioned in those openings and coupled with chassis **102**. The position of the plurality of openings (**730**, **740**) in chassis **102** may be different than depicted and there may be more than two openings. Sensor **750** and **760** need not be identical types or configurations of sensors and have different operating characteristics and may output different signals in response to expansion, contraction, or nominal forces. As described above in respect to FIG. 7A, expansion and contraction of openings (**730**, **740**) cause signals  $S_i$  or  $S_C$  to be generated. As describe above nominal signal  $S_0$  may be determined over time for each sensor **750** and **760**. Here, sensor **750** may experience different applied forces than sensor **760** in response to expansion and contraction of body portion **101** or in response to a nominal condition of body portion **101**. Over time, signals  $S_i$  and/or  $S_C$  from sensor **750** and **760** may be sampled or otherwise processed to determine if body portion **101** is inflamed or contracted. For example, if over a period of time (e.g., approximately 9 hours) signals from both sensors (**750**, **760**) are indicative of a trend of increasing generated signal strength, that trend may be analyzed to determine inflammation is present in body portion **101** and likely elsewhere in the body of the user **800**. Previous nominal signal  $S_0$  values may be used to validate the upward trending signals (e.g.,  $S_i$ ) from both sensors (**750**, **760**) that are indicative of inflammation. Similarly, for downward trending signals from both sensors (**750**, **760**), a determination may be made (e.g., including using previous nominal signal  $S_0$  values) that body portion **101** has shrunken due to dehydration or other cause. A voting protocol may be invoked when there is an unresolvable difference between the signals from both sensors (**750**, **760**) such that sensor **750** indicates contraction and sensor **760** indicates expansion. If chassis **102** is configured to include three or more sensors disposed in three or more gaps, then the voting protocol may determine inflammation or contraction when a majority of the sensors indicate inflammation or contraction (e.g., 2 out of 3 sensors or 4 out of 5 sensors), for example.

**[0065]** Referring now to FIG. 7C where three examples **770c-700e** depict another example configuration for device **100**. In example **700c**, body portion **101** is inserted or otherwise coupled with a flexible structure **770** in which one or more sensors **710** may be coupled with or may be disposed in flexible structure **770**. Chassis **102** may surround or otherwise be in contact with or coupled with the flexible structure **770** along an interior **102i** of the chassis **102**. Body portion **101** may be completely surrounded by or otherwise in contact with or coupled with the flexible structure **770** along an interior **770c** of the flexible structure **770**. Flexible structure **770** may be made from a variety of materials that are flexible and/or may be repeatedly expanded and contracted in shape

when pressure or force is exerted on the material. Examples include but are not limited to Sorbothane, Foam, Silicone, Rubber, a balloon or bladder filled with a fluid such as a gas or liquid or viscous material such as oil, and a diaphragm, just to name a few.

**[0066]** In example **700c** body portion **101** is depicted inserted into device **100** and having dimension  $D_0$  for the nominal state so that an approximate thickness between **102i** and **770c** is denoted as  $T_1$ . As body portion **101** expands and contracts, flexible structure **770** may also expand and contract as denoted by dashed arrow **117**. One or more of the sensors **710** may be positioned within the flexible structure **770** so that as the flexible structure **770** expands or contracts, forces from the expansion or contraction may couple with the sensor **710** and the sensor **710** may generate a signal (e.g.,  $S_0$ ,  $S_C$ ,  $S_i$ ) responsive or otherwise indicative of the force being applied to it. Other locations for sensor **710** may be within an aperture or other opening formed in chassis **102** and operative to allow forces from the expansion or contraction of **770** to couple with the chassis mounted sensor **710**. Both non-limiting examples for the configurations for sensor **710** are depicted in example **700c** and there may be more or fewer sensors **710** than depicted and other sensor locations may be used.

**[0067]** In example **700d** the body portion **101** has expanded from dimension  $D_0$  to  $D_i$  dimension such that approximate thickness between **102i** and **770c** has reduced from  $T_1$  to  $T_2$ . Here, sensor(s) **710** may generate signal  $S_i$  indicative of possible inflammation. In contrast, in example **700e** the body portion **101** has contracted from dimension  $D_0$  (or other dimension such as  $D_i$ ) to  $D_c$  dimension such that approximate thickness between **102i** and **770c** has increased from  $T_1$  (or other thickness such as  $T_2$ ) to  $T_3$ . Here, sensor(s) **710** may generate signal  $S_C$  indicative of possible contraction (e.g., dehydration). The examples **700c-700e** and configurations for device **100** depicted in FIG. 7C may be used to implement a device **100** such as the rings depicted in FIGS. 6A and 6G or bracelets in FIGS. 6B-6D, for example. As one example, flexible structure **770** may be used for the deformable structure **673** of example **600g** in FIG. 6G.

**[0068]** Attention is now directed to FIG. 8A where a profile view of forces **820** and motions ( $T_x$ ,  $T_y$ ,  $T_z$ ,  $R_x$ ,  $R_y$ ,  $R_z$ ) acting on a user **800** having (e.g., wearing) a wearable device to detect inflammation **100** are depicted. In example **800a**, the user **800** may be in motion and/or the aforementioned forces may be acting on user **800**'s body such that motion signals may be generated by sensors in sensory system **340** in device **100** or other devices user **800** may have that may be configured to generate motion signals that may be communicated to device **100** and/or another system (e.g., **199**) for purposes of analysis, calculation, data collection, coaching, avoidance, etc. Although device **100** is depicted being worn about an arm (e.g., around the biceps) of user **800**, actual locations on the body of user **800** are not limited to the location depicted. Other non-limiting locations may include but are not limited to wrist **801** (e.g., a bracelet or band for device **100**), neck **803**, hand **805** (e.g., a ring for device **100**), leg **807**, head **809**, torso **811**, and ankle **813**, for example.

**[0069]** Movement of user **800**'s body or parts of the body (e.g., limbs, head, etc.) relative to the X-Y-Z axes depicted may generate motion signals and/or force signals (e.g.,  $S_0$ ,  $S_C$ ,  $S_i$ ) due to translation (T) and rotation (R) motions ( $T_x$ ,  $T_y$ ,  $T_z$ ,  $R_x$ ,  $R_y$ ,  $R_z$ ) about the X-Y-Z axes. As will be described in relation to subsequent FIGS., force signals (e.g.,  $S_0$ ,  $S_C$ ,  $S_i$ ) caused by motion of user **800** or imparted to user **800** by

another actor (e.g., a bumpy ride in a car), may need to be cancelled out, excluded, disregarded, or otherwise processed so as to eliminate errors and/or false data for force signals (e.g.,  $S_o$ ,  $S_c$ ,  $S_i$ ), that is, determining the state (e.g., nominal, contracted, inflamed) may require signal processing or other algorithms and/or hardware to separate actual data for force signals (e.g.,  $S_o$ ,  $S_c$ ,  $S_i$ ) from potentially false or erroneous data caused by motion or other inputs that may cause sensors (110, 710, 750, 760, 710) to output signals that are not related to or caused by changes in state of the body portion being sensed by device 100 and its various systems.

[0070] Accordingly, motion signals from sensor system 340 or other systems in device 100 or other devices may be used to filter out non-state related force signals (e.g.,  $S_o$ ,  $S_c$ ,  $S_i$ ) in real-time as the signals are generated, post signal acquisition where the signals are stored and later operated on and/or analyzed or both, for example. To that end, example 800b of FIG. 8B depicts user 800 running with device 100 worn about a thigh of the user 800. User 800 may be prone to overexerting herself to the point where inflammation may result from over training, for example. While user 800 is running, forces such as those depicted in FIG. 8A may act on sensors (e.g., 110) in device 100 and some of that force may generate signals from the sensors that may require filtering using motion signals from motion sensors or the like to cull bad or false signal data from actual state related signal data. As one example, a cadence of user 800 as she runs may generate motion signals that have a pattern (e.g., in magnitude and/or time) that may approximately match the cadence of user 800. Sensors (e.g., 110) coupled with the body portion (e.g., thigh where device 100 is positioned) to be sensed may also experience forces generated by the cadence (e.g., foot-falls, pumping of the arms, etc. associated with running) and signals generated by the sensors may also approximately match the cadence of user 800. The amount of signal data generated by the sensors during the running may be highly suspect as legitimate state related signals because of the repetitive nature of those signals due to the cadence and the simultaneous occurrence of motion signals having a similar pattern or signature as the cadence. Generated force signals (e.g.,  $S_o$ ,  $S_c$ ,  $S_i$ ) may be ignored when the user 800 is running, may be compared with the motion signals or otherwise filtered using data from the motion signals to derive more accurate state related signals, which may indicate that inflammation is occurring (e.g., body portion 101 may show a trend of expansion) during the running due to an excessive workout, an injury, etc. On the other hand, during the running the filtered/processed state signals may indicate contraction is occurring because user 800 has not been properly hydrating her-self (e.g., drinking water) during the running and some trend of shrinkage of the body portion 101 is indicated. In other examples, taking all signal inputs that may be necessary to filter out bad data, etc., the state related signals may indicate no significant deviation of the body portion 101 from the nominal state (e.g., the body portion has not indicated a trend towards expansion or contraction).

[0071] FIGS. 8C-8G depict examples 800c-800g of other activities of a user 800 that may or may not require additional signal processing and/or analysis to determine accurate state related signals. As one example, going from left to right in FIGS. 8C-8E, the amount of additional signal processing that may be necessary for example 800c where the user 800 is walking may be more than is required for example 800d where the user 800 is standing, and may be even less for

example 800e where the user 800 is sitting down. In contrast, example 800f depicts a user 800 rowing and that activity may require additional signal processing as compared with example 800g where the user 800 is resting or sleeping. Example 800g also depicts one example of a multi-device 100 scenario where user 800 has two of the devices 100, one device 100 on a finger of the right hand and another device 100 on the left ankle. In the multi-device 100 scenario there may be a plurality of the devices 100 (e.g., see 800c, 800f, 800g). Those devices 100 may operate independently of one another, one or more of those devices 100 may work in cooperation or conjunction with one another, and one of those devices 100 may be designated (e.g., by user 800 or an APP 661, 651) as or act as a master device 100 that may control and/or orchestrate operation of the other devices 100 which may be designated (e.g., by user 800 or an APP) as or act as subordinate devices 100. Some or all of the devices in a multi-device 100 scenario may be wirelessly linked with one another and/or with an external system or devices (e.g., 199, 680, 690, 200). A single device 100 or multiple devices 100 may be used to gather data about a user's activity, such as motion profiles of how the user 800 walks or runs, etc. In example 800c, devices 100 may be used to gather historical data or other data on user 800's gait while in motion. Gait detection may include but is not limited to detecting accelerometry/motion associated with heel strikes, forefoot strikes, midfoot strikes, limb movement, limb movement patterns, velocity of the body, movement of different segments of the body, pumping and/or movement of the arms, just to name a few. Historical data and/or norms for the user, motion profiles, or other data about the user may be used as data inputs for processing/analysis of accelerometry, motion signals, or other sensor signals or data (e.g., location/GPS data). Gait detection and/or monitoring may be used with or without historical data to determine one or more of biometric data (e.g., true resting heart rate, heart rate variability), physiological and/or psychological state (e.g., fatigue), etc., and those determinations, including indications I/C/N, may be made without active input or action taking by user 800, that is, the determinations may be made by device(s) 100 automatically without user intervention (e.g., a passive user mode). Moreover, those determinations and resulting outputs (e.g., reports, notifications, coaching, avoidance, user mood, etc.) may be handled by device(s) 100 on a continuous basis (e.g., 24 hours a day, seven days a week—24/7).

[0072] Referring now to FIG. 9 where a block diagram 900 of sensor systems, data communication systems, data processing systems, wireless client devices, and data systems that may be coupled with and/or in communication with a wearable device 100 to detect inflammation are depicted. Device 100 may use its various systems to collect and/or process data and/or signals from a variety of sensors and other systems. As one example, accurate determination of state (e.g., nominal, contracted, inflammation) of the user 800 may require a plurality of sensors and their related signals as depicted for sensor system 340 which may sense inputs including but not limited to activity recognition 901 (e.g., rest, sleep, work, exercise, eating, relaxing, chores, etc.), biological state 903 (e.g., biometric data), physiological state 905 (e.g., state of health of user 800's body), psychological state 907 (e.g., state of mental health of user 800's mind 800m), and environmental state 909 (e.g., conditions in environment around the user 800). There may be more of fewer inputs than depicted as denoted by 911 and some of the inputs

may be interrelated to one another. There may be more devices **100** than depicted as denoted by **991** and those devices **100** may be wirelessly linked **196** with one another.

**[0073]** Sensor system **340** may include but is not limited to sensors such as the aforementioned sensor(s) I/C/N **110** (e.g., for sensing force applied by body portion **101**), a gyroscope **930**, motion sensor **932** (e.g., accelerometry using an accelerometer), bioimpedance **934**, body temperature **939**, heart rate **931**, skin resistance **933** (e.g., GSR), respiratory rate **937**, location/GPS **935**, environmental conditions **940** (e.g., external temperature/weather, etc.), pulse rate **936**, salinity/out-gas/emissions **937** (e.g., from skin of user **800**), blood oxygen level **938**, chemical/protein analysis **941**, fatigue **942**, stress **948**, true resting heart rate (TRHR) **946**, heart rate variability (HRV) **944**, just to name a few. As will be described below, sensor system **340** may include sensors for detecting electrical activity associated with arousal activity in the sympathetic nervous system denoted as Arousal/SNS **943**. GSR **933** and bioimpedance **934** are non-limiting examples of SNS related sensors. Device **100** may use some or all of the sensor signals from sensor system **340**. In some applications, one or more of the sensors in sensor system **340** may be an external sensor included in another device (e.g., another device **100**) and signal data from those external sensors may be wirelessly communicated **196** to the device **100** by the another device or by some other system such as **199**, **963**, **970**, **960**, **977** (e.g., a communications and/or GPS satellite), for example. Other inputs and/or data for device **100** may include temporal data **921** (e.g., time, date, month, year, etc.), user data/history **920** which may comprise without limitation any information about and/or of and concerning the user **800** that may relate to health, diet, weight, profession/occupation (e.g., for determining potential stress levels), activities, sports, habits (e.g., the user **800** is a smoker), and status (e.g., single, married, number of children, etc.), and data **910** from (e.g., from sensor (s) **110**) related to the states of inflammation, contraction, and nominal, just to name a few. Processing, analysis, calculation, and other compute operations may occur internal to systems of device **100**, external to device **100** or both. The aforementioned compute operations may be offloaded to external devices/systems or shared between device **100** and other devices and systems. For example, client device **999** may include an APP **998** and processor(s) for performing the compute operations.

**[0074]** Device **100** based on analysis of at least a portion of the data may issue one or more notifications **980**, may issue coaching (e.g., proffer advice) **970**, may report **950** the state (I/C/N) to user **800**, and may issue avoidance **990** (e.g., proffer advice as to how to avoid future reoccurrences of inflammation, fatigue, stress, etc.). A data base may be used as a source for coaching data, avoidance data or both. Report **950** may comprise an indication of whether or not the user **800** has systemic inflammation, is experiencing contraction (e.g., related to dehydration), or is in a nominal state. Notifications **980** may comprise a wide variety of data that may be communicated to user **800** including but not limited to notice of stress levels indicated by some of the data that was processed, steps user **800** may take to remediate inflammation, contraction or other conditions, locations for food, drink or other dietary needs of the user **800**, just to name a few. As one example, if user **800** is experiencing inflammation caused by high dose of sugar (e.g., from eating ice cream), then using location data **935**, device **100** may notify user **800** of a nearby coffee shop where a caffeinated drink may be obtained as an

anti-inflammatory. Coaching **970** may include but is not limited to advising and/or offering suggestions to the user **800** for changing behavior or to improve some aspect of the wellbeing of the user **800**. As one example, if user **800** is bicycling 25 miles each day non-stop (e.g., without sufficient breaks for water or rest), coaching **970** may advise user **800** that inflammation being detected by device **100** may be the result of overdoing his/her exercise routine and may suggest more stops along the route to rest and hydrate or to reduce the speed at which the user **800** is peddling the bicycle to reduce stress to the muscles, etc.

**[0075]** The Report **950**, Notifications **980**, Coaching **970**, and Avoidance **990** may be presented to user **800** in any number of ways including but not limited to one or more of a display on device **100** or a client device (e.g., **999**), an email message, a text message, an instant message, a Tweet, a posting to a blog or web page, a message sent to a professional or social media page, and an audio message, just to name a few. The information/data in Report **950**, Notifications **980**, and Coaching **970**, and the method in which the information/data is communicated may be as varied and extensive as hardware and/or software systems may allow and may evolve or change without limitation. Although I/C/N is depicted in regards to **910** and **950**, other conditions affection user **800** such as true resting heart rate (TRHR), fatigue (e.g., due to stress or other) may also be included in one or more of the user data history **920**, the coaching **970**, the avoidance **990**, the notifications **980**, the reports **950**, as will be described below.

**[0076]** Now, FIG. **10** depicts one example of a flow diagram **1000** for measuring, identifying, and remediating inflammation in a wearable device to detect inflammation **100**. At a stage **1001** and/or a stage **1005**, sensor signals (e.g., from sensor system **340**) may be measured, with a first set of signals measured from sensors for inflammation/contraction/nominal states (e.g., **110**) and a second set of signals from other sensors (e.g., motion and biometric). Stages **1001** and **1005** may occur in series, in parallel, synchronously or asynchronously. For example, second set of signals from motion sensors may be measured at the same time as the first set of signals from sensor(s) **110**. The stage **1001**, the stage **1005** or both may repeat at stages **1003** and **1007** respectively. Repeating at the stages **1003** and **1007** may comprise continuing to measure the first and/or second signals or restarting the measurement of the first and/or second signals.

**[0077]** At a stage **1009** analysis may be performed on the first and second signals to determine which of the three states the user may be in and to correct data errors (e.g., to remove false I/C/N data caused by motion). Stages **1001** and/or **1005** may be repeating (**1003**, **1007**) while stage **1009** is executing or other stages in flow **1000** are executing.

**[0078]** **[0078]**At a stage **1011** a decision may be made as to whether or not to apply almanac data to the analysis from the stage **1009**. If a YES branch is taken, then flow **1000** may access the almanac data at a stage **1013** and stage **1013** may access an almanac data base **1002** to obtain the almanac data. Almanac DB **1002** may include historical data about a user of device **100**, data about the environment in which the user resides and other data that may have bearing on causing or remediating inflammation and/or contraction and may be used to guide the user back to a nominal state. Flow **1000** may transition to another stage after execution of the stage **1013**, such as a stage **1019**, for example. If the NO branch is taken, then flow **1000** may continue at a stage **1015** where a decision to apply location data (e.g., from GPS tracking of a client

device associated with the user—e.g., a smartphone or tablet). If a YES branch is taken, then flow **1000** may transition to a stage **1017** where location data is accessed. Accessed data may be obtained from a location database which may include a log of locations visited by the user and associations/connections of those locations with user behavior such as locations of eateries frequented by the user, locations associated with events that may cause stress in the user (e.g., commute or picking up the kids from school), and other forms of data without limitation. Flow **1000** may transition to another stage after execution of the stage **1017**, such as a stage **1019**, for example. If the NO branch is taken, then flow **1000** may transition to a stage **1019** where some or all of the data compiled from prior stages may be analyzed and flow may transition from the stage **1019** to a stage **1021**.

**[0079]** At the stage **1021** a determination may be made as to whether or not the analysis at the stage **1019** indicates inflammation, contraction, or nominal state (I/C/N). In some applications the stage **1021** may only determine if inflammation (I) or contraction (C) are indicated and the nominal state (N) may not figure into the decision. If a NO branch is taken, then flow **1000** may proceed to a stage **1023** where a report of the indication at the stage **1021** may be generated. At a stage **1025** a decision as to whether or not to delay the report generated at the stage **1023** may be made with the YES branch adding delay at a stage **1027** or the NO branch transitioning flow **1000** to another stage, such as stages **1005** and/or **1001**. The NO branch from the stage **1021** may mean that the data as analyzed thus far may be inconclusive of an indication of I/C/N and the return of flow **1000** back to stages **1005** and/or **1001** may comprise reiterating the prior stages until some indication of I/C/N occurs. The adding of delay at the stage **1027** may be to operative to add wait states or to allow signals received by sensor system **340** to stabilize, for example.

**[0080]** If the YES branch is taken from the stage **1021**, then flow **1000** may transition to a stage **1029** where a notification process may be initiated and flow **1000** may transition to a stage **1031** where a determination as to whether or not a cause of inflammation or contraction is known. If a NO branch is taken, then flow **1000** may transition to a stage **1041** where delay at a stage **1045** may optionally be added as described above at a stage **1047** and flow **1000** may cycle back to stages **1005** and/or **1001**. Analysis at the stage **1019**, determining the indication at the stage **1021**, the reporting at the stage **1023** may include delaying taking any actions or proceeding to other stages in flow **1000** until a certain amount of time has elapsed (e.g., wait states or delay) to allow device **100** to re-calculate, re-analyze or other steps to verify accuracy of data or signals used in those stages. If a plurality of devices **100** are worn by user **800**, then a device **100** indicating inflammation or contraction may query other devices **100** to determine if one or more of those devices **100** concur with it by also indicating inflammation or contraction, for example.

**[0081]** If a YES branch is taken from the stage **1031**, then flow may transition to a stage **1033** where coaching and/or avoidance data may be accessed (e.g., from coaching/avoidance DB **1006** or other). Accessing at the stage **1033** may include an address for data in a data base (e.g., **1006**) that matches a known cause of the inflammation I or the contraction C. At a stage **1035** data from the data base (e.g., coaching and/or avoidance DB **1006**) is selected and at a stage **1037** advice based on the selection at the stage **1035** is proffered to the user in some user understandable form such as audio, video or both.

**[0082]** At a stage **1039** a decision to update a database may be made, such as the data sources discussed in FIG. **9**, may be updated. If a YES branch is taken, then flow **1000** may transition to a stage **1043** where one or more data bases are updated and flow may transition to the stage **1041** as described above. Here, flow **1000** may allow for data sources used by device **100** to be updated with current data or data used to analyze whether or not the user is undergoing I or C. Some or all of the stages in flow **1000** may be implemented in hardware, circuitry, software or any combination of the foregoing. Software implementations of one or more stages of flow **1000** may be embodied in a non-transitory computer readable medium configured to execute on a general purpose computer or compute engine, including but not limited to those described herein in regards to FIGS. **1A-1B**, **2**, **3**, **6A-6G**, **9** and **13**. Stages in flow **1000** may be distributed among different devices and/or systems for execution and/or among a plurality of devices **100**.

**[0083]** Hardware and/or software on device **100** may operate intermittently or continuously (e.g., 24/7) to sense the user **800**'s body and external environment. Detection and/or indication of (I/C/N) (e.g., using flow **1000** and/or other facilities of device **100**) may be an ongoing monitoring process where indications, notifications, reports, and coaching may continue, be revised, be updated, etc., as the device **100** and its systems (e.g., sensor system **340**) continue to monitor and detect changes in the user **800**'s body, such as in the dimension of the body portion **101**. Systemic inflammation may trend upward (e.g., increasing  $D_i$  over time), trend downward (e.g., decreasing  $D_i$  over time), transition back to nominal (e.g.,  $D_0$ ), transition to contracted (e.g.,  $D_c$ ), or make any number of transitions within a state or between states, for example.

**[0084]** Moving along to FIG. **11** where a block diagram of an example of a system **1100** including one or more wearable devices **100a-100e** to detect inflammation are depicted. Here system **1100** may include but is not limited to one or more client devices **999** (e.g., a wireless client device such as a smartphone, smart watch, tablet, pad, PC, laptop, etc.), resource **199**, data storage **1163**, server **1160** optionally coupled with data storage **1161**, wireless access point (AP) **1170**, network attached storage (NAS) **1167**, and one or more devices **100** denoted as wearable devices **100a-100e**. Some or all of the elements depicted in FIG. **11** may be in wireless communications **196** with one another and/or with specific devices. In some examples, some of the devices **100a-100e** may be configured differently than other of the devices **100a-100e**. There may be more or fewer devices **100a-100e** as denoted by **1190**.

**[0085]** User **800** may wear or otherwise don one or more of the devices **100a-100e** for detecting inflammation at one or more different locations **1101-1109** on user **800**'s body, such as a neck body portion **101a** for device **100a**, an arm body portion **101b** for device **100b**, a leg body portion **101c** for device **100c**, a finger body portion **101d** for device **100d**, and a torso body portion **101e** for device **100e**, for example. User **800** may also don one or more other wearable devices such as a data capable strap band, a fitness monitor, a smart watch or other devices and sensor data from one or more of the other devices may be wirelessly communicated (**196**) to one or more of: the devices **100a-100e**; client device **999**; resource **199**; server **1160**, AP **1170**; NAS **1167**; and data storage (**1161**, **1163**), for example. As one example, user **800** may don a data capable wireless strapband **1120** positioned **1111** on a

wrist body portion of user **800**'s left arm. Motion signals and/or biometric signals from other device **1120** may be wirelessly communicated **196** as described above and may be used in conjunction with other sensor signals and data to determine the state (I/C/N) of user **800** as described herein (e.g., as part of flow **1000** of FIG. **10**).

[**0086**] User **800**, client device(s) **999**, and devices **100a-100e** may be located in an environment that is remote from other elements of system **1100** such as resource **199**, AP **1170**, server **1160**, data storage **1163**, data storage **1161**, NAS **1167**, etc., as denoted by **1199**. Wireless communication link **196** may be used for data communications between one or more of the elements of system **1100** when those elements are remotely located. One of the devices **100a-100e** may be designated as a master device and the remaining devices may be designated as slave devices or subordinate devices as was described above. In some examples, regardless of a master/slave designation for the devices **100a-100e**, the client device **999** may oversee, control, command, wirelessly (**196**) gather telemetry from sensor systems **340** of the devices **100a-100e**, wirelessly query the devices **100a-100e**, and perform other functions associated with devices **100a-100e** (e.g., using APP **998**).

[**0087**] As was described above in reference to flow **1000**, first and second sensor data from one or more of the devices **100a-100e** may be wirelessly (**196**) communicated to client device **999** as denoted by **1150**. Client device **999** may perform processing and/or analysis of the sensor data or other data as denoted by **1151**. Client device **999** may generate reports related to user **800**'s state (e.g., I/C/N) or other biometric, physiological, or psychological information concerning user **800**'s body, as denoted by **1153**. Client device **999** may access data from one or more of the devices **100a-100e** and/or other elements of system **1000**, such as other device **1120**, resource **199**, server **1160**, NAS **1167**, or data storage (**1161**, **1163**) as denoted by **1155**. Client device **999** may process data and present coaching advice/suggestions as denoted by **1154**, avoidance advice/suggestions as denoted by **1159**, present notifications as denoted by **1152**, and those data may be presented on a display of client device **999** or elsewhere, for example. Over Time as user **800**'s body changes and other environmental conditions that affect the user **800** change, client device **999** may calculate and set a baseline for a body part dimension  $D_0$  and later as more Time has gone by, client device **999** may reset (e.g., re-calculate) the baseline, such that the baseline for  $D_0$  may change over Time. In some examples, some or all of the functions performed by client device **999** may be performed by resource **198** (e.g., as denoted by **1150-1159**), server **1160** or both.

[**0088**] Now, as was described above, determining the state (e.g., I/C/N) or the state of other biometric, physiological, or psychological information concerning user **800**'s body may not be instantaneously determinable and may in many cases be determinable over time. In FIG. **11**, a temporal line for Time, another line for associated Activity of user **800**, and a dashed line for Sampling of sensor data/signals and other data as described herein may be depictions of an ongoing process that continues and/or repeats over Time at a plurality of different intervals for the Time, Activity, and Sampling as denoted by  $t_0-t_n$  for Time,  $a_0-a_n$  for Activity, and  $S_0-S_n$  for Sampling. One or more of the Activity and/or Sampling may continuously cycle **1177** over Time such that data from sensors and activity may be gathered, analyzed, and acted on by one or more elements of system **1100**. As one example, a

baseline value for dimension  $D_0$  may change over Time as the activities of user **800** change and/or as changes occur within the body of user **800**, such that over Time data from Sampling and Activity may result in dimension  $D_0$  being repeatedly set and reset at Time progresses as described above in reference to **1157**.

[**0089**] Given that Activity and/or Sampling may continuously cycle **1177** over Time, first and second sensor data may be changing, dimension  $D_0$  may be changing, and therefore the data for determining the state (I/C/N) of user **800** may also be changing. Therefore, devices **100** and associated systems, client devices, and other elements, such as those depicted in FIG. **11** for system **1100** may be configured to adapt (e.g., in real time or near real time) to dynamic changes to user **800**'s body (e.g., health, weight, biometric, physiological, or psychological data, body portion **101** dimensions, baseline dimension  $D_0$ , etc.) to determine when signals from sensors **110**, including any processing to eliminate errors caused by motion or other factors, are indicative of inflammation, contraction, or nominal states.

[**0090**] For example, when user **800** is asleep, Activity may be at minimum and Sampling may occur less frequently. On the other hand, when the user **800** is swimming, Activity may be high and Sampling may occur more often than when the user is sleeping. As lack of sleep may manifest as inflammation of body tissues, while the user **800** sleeps, motion signals from sensor system **340** or other sensors may be of lower magnitude and/or frequency, such that little or no processing may be required to determine if signals from sensors **110** are indicative of inflammation caused by lack of sleep. When user **800** wakes up, one or more of reports **1153**, notifications **1152**, or coaching **1154** may be presented to user **800** informing user **800** (e.g., using client device **999**) of the inflammation and optionally advising or suggesting to user **800** steps to take (e.g., in diet, behavior, activity, stress reduction, fitness, etc.) to remediate the inflammation.

[**0091**] As another example, if user **800** is not properly hydrating (e.g., taking in enough fluids such as water), then while sleeping, little or no processing may be required to determine if signals from sensors **110** are indicative of contraction potentially caused by dehydration. When user **800** wakes up, one or more of reports **1153**, notifications **1152**, or coaching **1154** may be presented to user **800** informing user **800** (e.g., using client device **999**) of the inflammation and optionally advising or suggesting to user **800** steps to take (e.g., in diet, behavior, activity, stress reduction, drink more water before exercising/swimming, how much more water to drink, etc.) to remediate the contraction.

[**0092**] Conversely, while user **800** is swimming, motion signals from sensor system **340** or other sensors may be of higher magnitude and/or frequency than when user **800** is sleeping, such that additional processing may be required to determine if signals from sensors **110** are indicative of inflammation caused by over training, strained or injured muscles/tissues, etc. After the swimming is over, ongoing sampling and processing of sensor data may determine that inflammation has been detected and the user **800** may be informed (e.g., using client device **999**) via reports, notifications, etc., of the inflammation and optionally advising or suggesting to user **800** steps to take (e.g., in workout routine) to remediate the inflammation.

[**0093**] In FIG. **11** devices **100a-100e** and **1120** may be configured to sense different activity in body of user **800** and may wirelessly communicate **196** data from their respective

sensors, such as **100a** being configured to sense fatigue, TRHR, I/C/N, and accelerometry (ACCL), **1120** configured to sense ACCL, **100d** configured to sense I/C/N, TRHR, and ACCL, **100e** configured to sense Fatigue and ACCL, **100b** configured to sense I/C/N and ACCL, and **100c** configured to sense I/C/N, fatigue, and TRHR, for example. In some examples, devices **100a-100e** and **1120** may be configured to sense more or fewer types of activity than depicted.

[0094] FIGS. 12A-12C depict different views of examples **1200a-1200c** of a wearable device **100** to detect inflammation. In FIG. 12A, chassis **102** may comprise a flexible material and/or structure (e.g., a space frame, skeletal structure, spring or flat spring) configured to retain a shape once flexed or otherwise wrapped around or mounted to the body portion to be sensed by device **100** (e.g., the wrist, arm, ankle, neck, etc.). Exterior portions of chassis **102** may include a covering **102e** that may include ornamental and/or functional structures denoted as **1295**, such as for an aesthetic purpose and/or to aid traction or gripping of the device **100** by a hand of the user. Components of device **100** as described above in FIGS. 1 and 3 may be positioned within chassis **102**. A variety of sensors may be positioned at one or more locations in device **100**. As one example, sensor(s) **110** may be positioned on the interior portion **102i** so as to be positioned to couple with or contact with body portion **101** (see FIG. 12B) for sensing **345** force exerted by the body portion **101**. Similarly, other sensors, such as those for sensing biometric or other data from user **800**'s body may also be positioned to sense **345** the body portion **101**, such as sensor **1228**. For example, sensor **1228** may include one or more electrodes (**1229**, **1230**) configured to contact tissue (e.g., the skin) of body portion **101** and sense electrical activity of the sympathetic nervous system (SNS) (e.g., arousal) on the surface of body portion **101**, below the surface or both (e.g., dermal or sub-dermal sensing). Sensor **1228** and electrodes (**1229**, **1230**) may be configured for sensing one or more of GSR, EMG, bioimpedance (BIOP) or other activity related to arousal and/or the SNS. Optionally, other sensors may be positioned in device **100** to sense **347** external events, such as sensor **1222** (e.g., to sense external temperature, sound, light, atmosphere (smog, pollution, toxins, cigarette smoke, chemical outgassing) etc.), or sensors **1220**, **1224**, **1226** for sensing motion. Device **100** may include a wired communication link/interface **338** such as a TRS or TRRS plug or some other form of link including but not limited to USB, Ethernet, FireWire, Lightning, RS-232, or others. Device **100** may include one or more antennas **332** for wireless communication **196** as described above.

[0095] In a cross-sectional view of FIG. 12B, an example positioning of components/systems of device **100** is depicted. Here, a substructure **1291**, such as the aforementioned space frame, skeletal structure, spring or flat spring, may be connected with components or systems including but not limited to processor **310**, data storage **320**, sensors **110**, communications interface **310**, sensor system **340**, **340a**, **340b**, I/O **360**, and power system **350**. Bus **111** or bus **301** may be routed around components/systems of device **100** and be electrically coupled with those components/systems. Some systems such as sensor system **340** may be distributed into different sections such as **340a** and **340b**, with sensors in **340a** sensing **345** internal activities in body portion **110** and sensor **340b** sensing **347** external activities. Port **338** is depicted as being recessed and may be a female USB port, lightning port, or other, for example. Port **338** may be used for wired communications and/or supplying power to power system **350**, to

charge battery **355**, for example. Body portion **101** may be positioned within the interior **102i** of chassis **102**.

[0096] FIG. 12C depicts a profile view of another example positioning of internal components of device **100**. An optional cap **1295** may be coupled with chassis **102** and may protect port **338** from damage or contamination when not need for charging or wired communications, for example. A transducer **364**, such as a speaker and/or vibration motor or engine may be included in device **100**. Notifications, reports, or coaching may be audibly communicated (e.g., speech, voice or sound) to user **800** using transducer **364**. Device **100** may include a display, graphical user interface, and/or indicator light(s) (e.g., LED, LED's, RGB LED's, etc.) denoted as DISP **1280** which may be used to indicate a user's mood based on indications (I/C/N) and optionally other biometric data and/or environmental data as described above. The display and/or indicator lights may coincide with and/or provide notice of the above mentioned notifications, reports, or coaching. DISP **1280** may transmit light (e.g., for mood indication) or receive light (e.g., for ambient light detection/sensing via a photo diode, PIN diode, or other optoelectronic device) as denoted by **1281**. Chassis **102** may include an optically transparent/translucent aperture or window through which the light **1281** may pass for viewing by the user **800** or to receive ambient light from ENV **198**. As one example, one or more LED's **1282** may transmit light indicative of mood, as indications of (I/C/N), or other data. As another example, a photo-sensitive device **1283** may receive external light and generate a signal responsive to or indicative of an intensity of the light.

[0097] Referring now to FIG. 13 where a block diagram of an example **1300** of a cycle **1301-1306** of monitoring a user **800** having a wearable device to detect inflammation **100** and data inputs that may be used in a calculus for determining whether or not inflammation, contraction, or nominal states are indicated in the user **800** is depicted. There may be more or fewer data inputs than depicted in example **1300** as denoted by **1393**. As time **1320** progresses, device **100** may receive, analyze, and process sensed signals generated by sensor system **340** as denoted by the arrow **340**. At appropriate intervals, device **100** may communicate information including but not limited to notifications, advise, coaching, visual stimulus, audible stimulus, mechanical stimulus, user biometric data, data from sensor system **340**, motion signal data, data from sensors **110**, mood of user **800**, almanac data, historical data, or any combination of the foregoing as denoted by arrow **1399**.

[0098] Device **100** may receive information depicted in FIG. 13 and/or elsewhere herein from sources, systems, data stores, wireless devices, and devices, including but not limited to resource **199**, client device **999**, other wireless systems (e.g., via **196**), from other devices **100**, from other wireless devices such as exercise equipment, data capable strap bands, fitness monitors, smart watches or the like, reports, notifications, avoidance, coaching (RNC), compute engines (e.g., server **960** or computer system **200**), biometric data, almanac data, historical data, or any combination of the foregoing as denoted by arrow **1398** adjacent to device **100**.

[0099] In FIG. 13, one or more devices **100** may be included in an ecosystem **1310** of devices to measure inflammation or other health metrics (e.g., fatigue, resting heart rate) as denoted by **1390**. User **800** may wear device **100i** as a ring (e.g., see **600g** in FIG. 6G) about a finger and the communication of information denoted by arrows **340**, **1399**, and **1398** as described above may apply to one or more of the wearable

devices to detect inflammation and/or the other health metrics (e.g., such as **100**, **100i**) in ecosystem **1310**. For example, device **100** may communicate **196** data from its sensor system **340** to device **100i**, or vice-versa. As for the aforementioned three states of nominal (e.g., what is normal for user **800**), inflammation, and contraction, over time **1320**, dimension D of body portion **101** may vary in dimension from any of the aforementioned three states. Accordingly, over time **1320**, dimension D of body portion **101** may cycle between any of  $D_0$ ,  $D_i$ , and  $D_c$  as one or more of the items of data, activities, environment, events, sensor signals, sensor data, etc., depicted outside of the dashed line for ecosystem **1310** affect user **800** and manifest in the body of user **800** as one of the three states.

[0100] Accordingly, starting clockwise at  $D_0$ , dashed line **1301** depicts body portion **101** transitioning from nominal to contraction  $D_c$ , dashed line **1303** depicts body portion **101** transitioning from contraction to inflammation  $D_i$ , and dashed line **1305** depicts body portion **101** transitioning from inflammation to nominal  $D_0$ . Similarly, again using  $D_0$  as a starting point and going in a counter-clockwise direction, dashed line **1302** depicts body portion **101** transitioning from nominal to inflammation  $D_i$ , dashed line **1304** depicts body portion **101** transitioning from inflammation to contraction  $D_c$ , and dashed line **1306** depicts body portion **101** transitioning from contraction to nominal  $D_0$ . Therefore, over time **1320** the variations in dimension D of body portion **101b** may change and may transition to/from any of the three states (I/C/N), and device **100** may be configured to monitor those changes and take necessary actions with respect to those changes at any desired interval such as constant (e.g., 24/7), at a less frequent interval (e.g., every ten minutes, every hour, eight times a day, etc.), or in response to a change in one or more of the items of data, environment, events, etc., that are depicted outside of the dashed line for ecosystem **1310** that may affect user **800** and may trigger monitoring by one or more of the devices **100**. Although indications of the three states (I/C/N) may be monitored 24/7 or at some other interval, other biometric parameters (e.g., true resting heart rate), physiological state and/or psychological state (e.g., user fatigue) may be monitored as well, may be monitored in real time, and may be automatic with the user **800** being passive in his/her actions with respect to monitoring by device **100**.

[0101] As discussed above, there are a plurality of items of data, environment, events, etc., that are depicted outside of the dashed line for ecosystem **1310** and there may be more or less than depicted as denoted by **1393** and the depictions in FIG. **13** may be a non-exhaustive list and comprise non-limiting examples presented for purposes of explanation only. For purposes of clarity these examples will be referred to collectively as datum. The datum may affect one or more of user **800**'s mental state, physical state, or both. Some of the datum may affect other datum, such work **1333** may impact stress **1343**, for example. Or exercise **1338** may affect one or more types of biometric data **1378**, for example. As another example, resting heart rate (RHR) **1375** may be affected by whether or not the user **800** is at sleep **1342**, is at rest **1376**, is under stress **1343**, or is in a state of relaxation **1355**. Some of the datum's may be data sensed by, collected by, processed by, or analyzed by one or more of the devices **100** or some other device. Some of the datum's may comprise specific data about user **800** and that data may or may not be static, and may include but is not limited to weight and/or percent body fat **1362**, health data **1341** (e.g., from health history or health

records), family **1335** (e.g., married, single, children, siblings, parents, etc.). Some of the datum's may be analyzed in context with other datum's, such as food/drink **1351**, sugar **1363**, or diet **1340** being analyzed in conjunction with location data **1360** which may be provided by an internal system of devices **100** and/or an external device (e.g., client device **999** or resource **199**). For example, if user **800** experience inflammation (e.g., as reported by device **100** and/or **100i**) due to a high sugar dosage from drinking a chocolate milk shake at an ice cream shop, location data may include a coffee shop (e.g., from eateries data **1350**) the user **800** may be notified of via the notice function or coached to go to using the coaching function. The user **800** may be informed that caffeine may serve as an anti-inflammatory and to have a cup of coffee, latte, low or no sugar energy drink or other caffeinated drink/beverage to reduce the inflammation or return the user **800** to the nominal state. Location data may include history data from locations user **800** frequents, such as the ice cream shop, the coffee shop, grocery stores, restaurants, etc., just to name a few, for example. The reporting, notification, and coaching functions may again be invoked to inform the user **800** that his/her taking the prescribed action has either reduce the inflammation or returned the user's state to nominal.

[0102] Device **100i** may indicate a mood of the user **800** using indicator lights **1282** (e.g., LED's) (e.g., see also **560** and **562** in FIG. **5**) with only two of the five lights activated when the user **800** is experiencing the inflammation state due to the high sugar does and those two indicator lights **1282** may be indicative of the user **800** being in a sluggish or lethargic low energy mood due to insulin production in the user's body resulting from the high sugar dose. Conversely, after receiving the notification and/or coaching and taking affirmative action to remedy the inflammation by drinking the caffeinated beverage, four of the five indicator lights **1282** may activate to indicate reduced inflammation or a return to the nominal state. Those four indicator lights **1282** may be indicative of the user **800** being in a good mood (e.g., more energy). In some example, the reporting function may comprise using the indicator lights **1282** to report some change in body function or other information to user **800**.

[0103] One or more of the reporting, notification, avoidance, coaching (RNC) may be presented on a display of client device **999** (e.g., using a GUI or the like) in a format that may be determined by APP **998**, or other algorithms. Other systems of client device **999** may be used for RNC, such as a vibration engine/motor, ringtones, alarms, audio tones, music or other type of media, etc. As one example a song or excerpt from a song or other media may be played back when inflammation is detected and another song for when contraction (e.g., dehydration to extreme dehydration are indicated).

[0104] During the cycles depicted in FIG. **13**, one or more of the datum's may be updated and/or revised as new data replaces prior data, such as the case for changes in the user **800**'s weight or body fat percentage **1362**, diet **1340**, exercise **1338**, etc. The user **800** may input change in weight or body fat percentage **1362** using client device **999** (e.g., via the GUI and/or APP **998**), or the user may use a wirelessly linked scale that interfaces (e.g., wirelessly) with device **100**, device **100i**, or client device **999** and updates the weight/% body fat. The cycles depicted in FIG. **13** may run (e.g., be active on one or more devices **100**) on a 24/7 basis as described above and updates, revisions, and replacing prior data with new data may also occur on a 24/7 basis.

[0105] In FIG. 13 many non-limiting examples of information related to user 800 or having an effect on user 800 are depicted to illustrate how numerous and broad the information that may be used directly, indirectly, or produced directly or indirectly by one or more devices 100. The following non-limiting examples of information may include but are not limited to: internal data 1331 may include any form of data used and/or produced internally in device 100 and internal data 1331 may be a superset of other data in device 100 and/or depicted in FIG. 13; external data 1332 may include any form of data used and/or produced external to device 100 and may be a superset of other data depicted in FIG. 13; work 1333 may be information related to work the user 800 does or a profession of user 800; school 1334 may be information relating to user 800's education, current educational circumstances, schooling of user 800's children; family 1335 may relate to user 800's immediate and/or extended family and relatives; friends 1335 may relate to friends of user 800; relationships 1337 may relate to intimate and/or societal relationships of user 800; weight and/or percent body fat 1362 may comprise actual data on those metrics and/or user goals for those metrics; circumstances 1361 may comprise events past, present or both that may affect or are currently affecting user 800; athletics 1339 may be data regarding athletic pursuits of user 800; biometric 1378 may comprise data from one or more devices 100, data from medical records, real-time biometric data, etc.; location 1360 may comprise data relating to a current location of user 800, past locations visited by user 800, GPS data, etc.; exercise 1338 may comprise information regarding exercise activity of user 800, exercise logs, motion and/or accelerometer data associated with specific exercises and/or exercise routines; health data 1341 may be any information from any source regarding health of user 800, such as medical records, etc.; diet 1340 may be information on a diet regime of user 800, dietary instructions for user 800, nutrition requirements for a diet (e.g., calories, carbohydrates, food quantizes), etc.; stress 1343 may be actual stress in user 800 as passively determined by device(s) 100, historical data on stress or stressful situations related to user 800, etc.; sugar 1363 may comprise data on sugar intake by user 800 or sensor data indicating an effect of sugar on user 800, or locations (e.g., from location 1360) determined to be associated with high sugar intake by user 800 (e.g., an ice cream shop the user patronizes); at rest 1376 may include any data related to user 800 when the user is at rest and is not sleeping such as biometric data, respiration, arousal, HR, TRHR, HRV, accelerometry, etc.; sleep 1342 may include any data related to user 800 when the user is sleeping such as time of sleep, quality of sleep, respiration, arousal, biometric data, HR, TRHR, HRV, accelerometry, etc.; status 1359 may include data about user 800's social, professional, economic, or financial status as status may have bearing on the emotional and/or physical state of user 800; inactivity 1346 may include data on periods and/or patterns of inactivity of user 800 and sensor data associated with the inactivity such as accelerometry, arousal, HR, HRV, TRHR, arousal, and other biometric data, where inactivity may be one indicator of fatigue and/or depression; travel 1347 may include any data related to how travel may affect user 800 such as stress, fatigue, HR, HRV, arousal, biometric data, diet, sleep, I/C/N, etc., travel 1347 may be combined with other data such as location data 1360 to determine if travel to/from certain destinations have a positive or negative physical and/or mental impact on user 800; commute 1344 may include any data related to how

commuting may affect user 800 such as stress, fatigue, HR, HRV, arousal, biometric data, diet, sleep, I/C/N, etc., travel 1347 may be combined with other data such as location data 1360 or travel 1347 to determine if commuting to/from certain destinations, commute distances, commute times, etc., have a positive or negative physical and/or mental impact on user 800; RESP 1345 may include any data related to respiration of user 800 such as at rest, while sleeping, when under stress, when fatigued, when dehydrate or suffering inflammation (I/C/N), during exercise or other forms of physical exertion, mental exertion, etc.; depression 1352 may include any data related to depression in user 800 include mental or health records, past incidents of detected depression, fatigue, stress, accelerometry, arousal, biometric data, etc.; news 1357 may include any data related to news from a media source or other that may positively or negatively affect user 800 and news 1357 may be received on an external device such as client device 999 and APP 998 may be configured to parse news of interest to user 800 and push data for relevant news (e.g., affects user 800) to device 100; mood 1353 may include any data relating to a mood (e.g., physical and/or mental) of user 800 such as feeling up, down, depressed, fatigued, stressed, or one of the moods indicated by indicators (1282, 561) of devices 100i or 100; finances 1356 may include any data related to financial status or circumstances related to user 800 as financial conditions may have an effect on the mental and/or physical state of user 800; weather 1350 (e.g., weather conditions) may affect user 800's mind 800m and/or body 1350 and may include any data including data from web sites, other locations, or sources that monitor or forecast weather and weather 1350 may be used in conjunction with location 1360 to determine weather conditions proximate the user 800's current location, and weather 1350 may include historical data (e.g., collected over time) on how weather affects user 800; caffeine 1349 may include data on locations (e.g., from location 1360) where user 800 obtains food and/or drink containing, conditions under which user 800 resorts to taking caffeine, and amount of caffeine intake/consumption by user 800; eateries 1350 may include locations (e.g., from location 1360) where user 800 obtains nourishment, has meals, has snacks, has food/drink, etc. and location 1360) may be used to determine the types of food/drink associated with the eateries and that information may be used to determine diet information, compliance with a diet plan, for advice or counseling about diet, etc.; food/drink 1351 may include data on types and quantities of food and/or drink the user 800 has consumed and food/drink 1351 may be related to or used in conjunction with other data such as eateries 1350, caffeine 1349, sugar 1363, diet 1340, location 1360, or others; GAIT 1381 may include data regarding motion and/or accelerometry of user 800 including movement of limbs, speed of movement, patterns, duration of activity that generated data included in GAIT 1381, and history of previous GAIT data that may be compared against current and/or real-time gate data; seasons 1358 may be any data related to the seasons of the year and how those seasons affect user 800, seasons 1358 may be tied or otherwise used in conjunction with weather 1350; ACCL (accelerometry) 1379 may include any data (e.g., motion sensor signals) related to movement of user 800's body and may include real-time and/or historical data on accelerometry of user 800 under different conditions/activities, ACCL 1379 may include data that may be used to determine if motion of user 800 is too low (e.g., user 800 may be fatigued) or too high (e.g., user 800 is stressed or anxious); injury 1348 may

include any data relating to a current injury or history of past injuries to user **800** and may include data from other items such as health data **1341**; disease **1354** may include any data relating to a current disease or history of past diseases for user **800** and may include data from other items such as health data **1341**; relaxation **1355** may include any data related to activities associated with a relaxed state of user **800**'s mental state, physical state or both; arousal **1373** may include any data including historical data and sensor signals that relate to muscle and/or electrical activity in the sympathetic nervous system (SNS) of user **800**; SNS (sympathetic nervous system) **1372** may include any data including historical data and sensor signals (e.g., GSR, EMG) that relate to muscle and/or electrical activity in the sympathetic nervous system (SNS) of user **800** and may be similar to arousal **1373** and may include the same or different data than arousal **1373**; HR (heart rate) **1383** may be any data including sensor signals related to heartbeat (e.g., in bpm) of user **800** and may include historical data on heartbeat of user **800**; HRV (heart rate variability) **1383** may be any data including sensor signals related to HRV of user **800** and may include historical data on HRV of user **800**; TRHR (true resting heart rate) **1375** may include any data, history, real-time data, or other forms of information related to the TRHR of user **800**; temperature **1380** may include data about body temperature (e.g., in real-time) and/or historical body temperature of user **800**; and almanac data **1377** may broadly include any data that may be accessed by device(s) **100** or external devices that may be used in processing, calculating, analyzing, coaching, avoidance, reporting, notifications, advising, or the like and may include data generated by one or more systems of device(s) **100** such as the sensor system **340** or others.

[0106] One or more of the items of information/data described in the foregoing examples for FIG. **13** may be used for passively determining (e.g., in real-time) stress, fatigue, inflammation, contraction, nominal states (I/C/N), arousal of the SNS, true resting heart rate (TRHR), or other data that may be gleaned from user **800** using the systems of device(s) **100**, etc. as described herein. Data in some of the items of data may be duplicated and/or identical to data in other of the items of data. Device(s) **100** and/or external systems (e.g., **199** or **999**) may update, revise, overwrite, add, or delete data from one or more of the items depicted in FIG. **13**. As one or more of the devices **100** operate continuously (e.g., 24/7), on an intermittent basis or both, data in one or more of the items may be changed by new data from one or more of the devices **100**. Some of the devices **100** may access different sub-sets of the items such as devices **100** with only biometric sensor may not write data to ACCL **1379** but may read data from ACCL **1379**; whereas, a device **100** having motion sensors may write sensor data to ACCL **1379** and may optionally read data from ACCL **1379** (e.g., motion signal data from other wirelessly linked devices **100**) to perform analysis, calculations, etc. for example. Data in one or more items in FIG. **13** may be a source for data inputs (e.g., **1601-1617**) depicted in FIG. **16** below or may derive from signals generated by sensors in sensor system **340** (e.g., in FIG. **16**).

[0107] Attention is now directed to FIG. **14** where one example of a flow diagram **1400** for passively determining a true resting heart rate (TRHR) of a user **800** is depicted. At a stage **1401** sensors in sensor system **340** in device **100** or in another device **100** wirelessly linked with device **100** that are relevant to passively determining TRHR of user **800** may be parsed (e.g., scanned, interrogated, analyzed, queried,

receive, read, or activated). Relevant sensors may comprise all or a sub-set of sensors in sensor system **340** of device **100** and/or another device **100** that generate signals that may be processed, analyzed, or otherwise applied to determine the TRHR. Relevant sensors may comprise selected sensors in sensor system **340** of device **100** and/or another device **100** that generate signals that may be processed, analyzed, or otherwise applied to determine the TRHR. Passively may comprise the user **800** doing nothing at all (e.g., taking no action) to assist or otherwise make the determination of TRHR happen. In some examples, user **800** may instruct device(s) **100** (e.g., via the APP on client device **999**) to activate one or more modes of operation, such as the TRHR mode, the I/C/N mode as described above, or a fatigue mode, as will be described below. To that end, the only action on behalf of the user **800** may be to activate the TRHR mode. In some examples, the TRHR mode and/or determining TRHR may be automatically active on device(s) **100** (e.g., at power up) and the user **800** is passive as to its operation. Similarly, the I/C/N and fatigue determinations and/or modes may also be automatic and the user **800** is passive as to their operation.

[0108] At a stage **1403** signals from one or more sensors and/or sensor types for sensing motion may be analyzed to determine whether or not the user **800** is in motion. An indication of motion (e.g., above a threshold value in G's or G's unit of time G's/sec) may mean the user **800** is not at rest. If a YES determination is made, then flow **1400** may transition to another stage, such as cycling back to the stage **1401**, for example. TRHR may comprise a state of user **800** in which the user **800** is at rest (e.g., low or no accelerometry (motion signals attributed to human movement) in user **800**), is not asleep, and is not stressed (e.g., physically and/or mentally). Here, a YES determination of motion being sensed (e.g., via motion sensors in **340**) may indicate that the user **800** is not at rest and one or more biometric signals such as heart rate (HR), heart rate variability (HRV), or arousal activity in the sympathetic nervous system (SNS) may not be reliably used in a determination of TRHR, until such a time as the NO branch is taken from the stage **1403**. At rest may comprise the user **800** being awake (e.g., not sleeping) and not in motion, where not in motion may not mean absolutely still, but rather not exercising, not walking, not talking, etc. For example, at rest may comprise the user being awake and lying down on a sofa, sitting on a chair, or riding on a train?

[0109] If the NO branch is taken, then flow **1400** may transition to a stage **1405** where a determination may be made as to whether or not one signals from sensors in **340** indicate that the user **800** is asleep. Motion signals (e.g., from an accelerometer and/or gyroscope) and other signals such as biometric signals from HR sensors, HRV sensors, SNS sensors (e.g., GSR, EMG, bioimpedance), respiration sensors (RES), or others, may be used singly or in combination to determine if the user **800** is sleeping. If a YES branch is taken, then flow **1400** may transition to another stage, such as cycling back to the stage **1401**, for example. If a NO branch is taken, then flow **1400** may transition to a stage **1407** where signals from one or more sensors in **340** may be analyzed to determine if the user **800** is stressed. Motion signals (e.g., from an accelerometer and/or gyroscope) and other signals such as biometric signals from HR sensors, HRV sensors, SNS sensors (e.g., GSR, EMG, bioimpedance), respiration sensors (RES), I/C/N sensors **110**, or others, may be used singly or in combination to determine if the user **800** is stressed. Stress may comprise mental state (e.g., arousal in

the SNS), emotional state (e.g., angry, depressed), physical state (e.g., illness, injury, inflammation, dehydration), metal activity (e.g., solving a difficult problem), of some combination of those (e.g., fatigue) for example. If a YES branch is taken, then flow **1400** may transition to another stage, such as cycling back to the stage **1401**, for example. If a NO branch is taken, the flow **1400** may transition to a stage **1409**. A taking of the YES branch from one or more of the stages **1403-1407** which are denoted as group **1450** may comprise continually parsing the relevant sensors (e.g., in sensor system **340**) until analysis of signals from the relevant parsed sensors allows each NO branch in group **1450** to be taken so that flow **1400** arrives at the stage **1409**. For example, sensor signals indicating the user **800** is at rest, is not asleep, and is not stressed may allow entry into the stage **1409**.

[0110] At the stage **1409**, sensor signals that are relevant to a passive determination of TRHR are analyzed (e.g., using processor **310**). Passive determination, as described above, does not require any action on part of user **800**. Analysis at the stage **1409** may include using one or more sensors in **340** to determine the user **800**'s HR and/or HRV while the conditions precedent to entry into the stage **1409** are still present, that is the NO branches of group **1450** are still valid (e.g., user **800** is at rest, is not asleep, and is not stressed). Data **1402** may be used as an input for the analysis at the stage **1409**. Data **1402** may include but is not limited to normal values of HR, HRV, GSR, RES, EMG, BIOP, or other measured norms for user **800**. Data **1402** may include prior determined values of TRHR for user **800**, for example. Data **1402** may include one or more of the datum's described above in reference to FIG. **13**.

[0111] At a stage **1411**, a decision may be made as to whether or not the analysis at the stage **1409** has determined TRHR (e.g., in bpm) for user **800**. In a NO branch is taken, then flow **1400** may transition to another stage, such as cycling back to the stage **1401** where the stages in group **1450** may be repeated until all NO branches are taken to the stage **1409**. The NO branch may be taken for a variety of reasons, such as conflicting sensor signals, for example. As one example, if HR is increasing and HRV is also increasing, then stage **1411** may determine that a TRHR value passively determined at the stage **1409** is inaccurate due to both HR and HRV increasing, where, typically as HR increases, HRV decreases. As another example, if GSR increases and HR decreases, then conflict in those signal readings may cause execution of the NO branch as HR typically increases with an increase in GSR. As yet another example, if GSR is indicative of low stress in user **800**, but I/C/N indicates systemic inflammation, then there may be a conflict in those indicators because systemic inflammation typically affects arousal in the SNS and causes an increase in GSR. If a YES branch is taken, then TRHR has been determined and flow **1400** may transition to a stage **1413**.

[0112] At the stage **1413**, the TRHR may be reported (e.g., to a data store and/or display on client device **999** or other device) and/or analysis data (e.g., from stage **1409** and/or **1411**) may be reported (e.g., to a data store and/or display on client device **999** or other device). An example of a data store may include but is not limited to a data storage system in resource **199**, client device **999**, one or more devices **100**, DS **963**, DS **961**, the Cloud, the Internet, NAS, Flash memory, etc., just to name a few. In some examples, the stage **1413** may be optional and may not be executed in flow **1400**.

[0113] At a stage **1415** a determination may be made as to whether or not to store the analysis data. If a YES branch is taken, then at a stage **1417** relevant analysis data (e.g., TRHR or other data from stage **1409** and/or **1411**) is stored (e.g., in a data store **1404**). Data store **1402** may include data that was stored at the stage **1417**. One or more datum depicted in FIG. **13** may be revised and/or updated based on the analysis data. In some examples, data stores **1402** and **1404** may be the same data store. Subsequent to storing the data, flow **1400** may transition to a stage **1419**, which is the same stage flow **1400** may transition to if the NO branch was taken from the stage **1415**.

[0114] At the stage **1419** a determination may be made as to whether or not flow **1400** is Done (e.g., no more stages need to be executed). If a YES branch is taken, flow **1400** may terminate (e.g., END). If a NO branch is taken, flow **1400** may transition to a stage **1421**.

[0115] At the stage **1421**, a determination may be made as to whether or not a 24/7 mode is active (e.g., is set) on device(s) **100**. If a YES branch is taken, then flow **1400** may transition to another stage, such as to the stage **1401** to begin again the parsing of relevant sensor(s) as was described above. The taking of the YES may repeat over and over again so long as the 24/7 mode is set (e.g., either by default or user **800** setting the mode), such that passively determining the TRHR of user **800** is an ongoing process that repeats and may update values of TRHR as appropriate over time as changes in the user's **800** physical and mental states change over time. In some examples, algorithms and/or hardware in device(s) **100** may clear the 24/7 mode so that the NO branch will be taken at the stage **1421**. For example, if fatigue, inflammation, or dehydration are indicated, then device(s) **100** may clear the 24/7 mode and focus their processing, analysis, reporting, notifications, coaching, etc. on addressing those indications, and then at some later time the device(s) **100** may set the 24/7 mode so that the YES branch may be taken in future iterations of flow **1400**.

[0116] If the NO branch is taken, then flow **1400** may transition to a stage **1423** where a time delay may be added to delay transition of flow **1400** back to the stage **1401**. The time delay added may be in any time increment without limitation, such as sub-seconds, seconds, minutes, hours, days, weeks, etc.

[0117] Reference is now made to FIGS. **15A-15B** where two different examples (**1500a**, **1500b**) of sensed data that may be relevant to passively determining TRHR of the user **800** are depicted. In FIG. **15A**, group **1450** includes four determinations instead of the three (**1403-1407**) depicted in FIG. **14**. Here, assuming entry from a prior stage, such as the stage **1401** of FIG. **14**, at a stage **1451** one or more relevant sensor in **340** may be parsed to determine if the user **800** is awake (e.g., motion sensors and/or biometric sensors). At a stage **1453**, one or more relevant sensor in **340** may be parsed to determine if the user **800** is at rest (e.g., motion sensors and/or biometric sensors). At a stage **1455**, one or more relevant sensor in **340** may be parsed to determine if the user **800** is in motion (e.g., motion sensors, GAIT detection, biometric sensors). At a stage **1457**, one or more relevant sensor in **340** may be parsed to determine if the user **800** is stressed (e.g., biometric sensors, HR, HRV, GSR, BIOP, SNS, EMG). Successful execution of stages **1451-1453** (e.g., branches taking YES, YES, NO, NO) may transition the flow of example **1500a** to another stage, such as the stage **1409** of FIG. **14**.

[0118] In FIG. 15B, group 1450 includes three determinations that may be different than the three (1403-1407) depicted in FIG. 14. Here, assuming entry from a prior stage, such as the stage 1401 of FIG. 14, at a stage 1452 one or more relevant sensor in 340 may be parsed to determine if the user 800 is awake (e.g., motion sensors and/or biometric sensors). At a stage 1454, one or more relevant sensor in 340 may be parsed to determine if accelerometry of the user 800 is high (e.g., motion sensors, GAIT detection, location data). At a stage 1456, one or more relevant sensor in 340 may be parsed to determine if arousal in the SNS of user 800 is high (e.g., GSR, BIOP, SNS, EMG, I/C/N). Successful execution of stages 1452-1456 (e.g., branches taking YES, NO, NO) may transition the flow of example 1500b to another stage, such as the stage 1409 of FIG. 14. High accelerometry and/or high arousal may be threshold values that exceed normal values of accelerometry and/or arousal in the user 800 (e.g., normal values for user 800 when awake, at rest and not aroused).

[0119] The determinations in examples 1500a and 1500b may ask similar questions but may parse different sets of sensors to select a YES or NO branch. For example, high accelerometry at the stage 1454 may forego parsing biometric sensors; whereas, stages 1453 and 1455 may parse biometric sensors to determine if the user 800 is at rest and in motion. Stage 1454 may include parsing of biometric sensors as motion by user 800 may affect HR, HRV, SNS, etc. However, high accelerometry may be determined without parsing biometric sensors. There are a variety of relevant sensors that may be parsed to passively determine TRHR, and the above groupings are non-limiting examples only. In some examples, the number and/or types of sensors that are parsed may be changed or altered during execution of flow 1400, of example 1500a, or of example 1500b. As one example, if a determination fails and flow returns to the stage 1401, a mix of sensors used for the next pass through group 1450 may change (e.g., biometric sensor are parsed for the stage 1454 or I/C/N is parsed for the stage 1457).

[0120] Description now turns to FIG. 16 where a block diagram 1600 of non-limiting examples of relevant sensor signals that may be parsed, read, scanned, and/or analyzed for passively determining a true resting heart rate (TRHR) of a user are depicted. Referring back to FIG. 3, sensor system 340 of device 100 may include a plurality of different types of sensors (e.g., force and/or pressure 110, motion, biometric, temperature, etc.) and signals from one or more of those sensors may be coupled (341, 301) with processor 310, data storage 320, communications interface 330, and other systems not depicted in FIG. 16. Communications interface 330 may transmit 196 via RF system 335 sensor signals from 340 and/or may receive 196 sensor signals via RF system 335 from one or more of other devices 100, external systems, and wireless client devices, for example. Sensor signals from 340 may be stored for future use, for use in algorithms executed internally on processor 310 and/or externally of device 100, may be stored as historical data, may be stored as one or more datum's depicted in FIG. 13, for example.

[0121] In sensor system 340, examples of sensors and their respective signals that may be relevant to determining TRHR and/or other states/conditions of user 800's physical and/or mental state (e.g., I/C/N, fatigue, mental state of user 800's mind 800m, etc.) include but are not limited to: sensor 1601 for sensing heart rate (HR); sensor 1602 for sensing heart rate variability (HRV); sensor 1603 for sensing activity (e.g., electrical signals) associated with the sympathetic nervous sys-

tem (SNS) which may include activity associated with arousal; sensor 1604 for sensing motion and/or acceleration, such as a single-axis accelerometer or a multiple-axis accelerometer (ACCL); sensor 1605 for sensing motion and/or acceleration, such as one or more gyroscopes (GYRO); sensor 1606 for sensing inflammation, nominal, and contraction states of tissues of a user (e.g., sensor 110) (I/C/N); sensor 1607 for sensing respiration (RES); sensor 1608 for sensing bioimpedance (e.g., using sub-dermal current applied by electrodes) (BIOP); sensor 1609 for sensing electromyography (EMG); sensor 1610 for sensing skin conductivity, galvanic skin response, etc., at the dermal layer (GSR); sensor 1611 for sensing an internal temperature of user 800's body (TEMPI); sensor 1612 for sensing temperature external to user 800's body (e.g., ambient temperature) (TEMPe); sensor LOC 1613 for sensing location of user 800 via GPS or other hardware (e.g., client device 999) and/or software; and sensor IMG 1615 for image data (e.g., micro-expression detection/recognition, facial expression and/or posture recognition). IMG 1615 may be from image capture device 369 of FIG. 3, for example. IMG 1615 may be positioned in an external device (e.g., client device 999) and image data from IMG 1615 may be wirelessly transmitted to one or more devices 100 or to an external resource (e.g., 199, 960, 999) for processing/analysis, for example.

[0122] In some examples, device 100 or another device or system in communication with device 100 may sense an environment (e.g., 399) user 800 is in for environmental conditions that may affect the user 800, such as light, sound, noise pollution, atmosphere, etc. Sensors such as light sensors, ambient light sensors, acoustic transducers, microphones, atmosphere sensors, or the like may be used as inputs (e.g., via sensor signals, data, etc.) for sensor system 340 or other systems and/or algorithms in device 100 or a system processing data on behalf of one or more devices 100. ENV 1617 denotes one or more environmental sensors. More or fewer sensors may be included in sensor system 340 as denoted by 1642.

[0123] Some of the sensors in 340 may sense the same activity and/or signals in body of the user 800, such as EMG 1609, BIOP 1608, GSR 1610 which may be different ways of sensing activity in the sympathetic nervous system (SNS) and those sensors may be sub-types of SNS 1603. As another example, ACCL 1604 and GRYO 1605 may sense similar motion activity of user 800 as depicted by the X-Y-Z axes. GRYO 1605 may provide motion signals for rotation Rx, Ry, Rz about the X-Y-Z axes and ACCL 1604 may provide motion signals for translation Tx, Ty, Tz along the X-Y-Z axes, for example. In some examples, some of the sensors depicted may be determined by applying calculations and/or analysis on signals from one or more other sensors, such as sensing HR 1601 and calculating HRV from signal data from HR 1601. Signals from one or more sensors may be processed or otherwise analyzed to derive another signal or input used in determining TRHR, such as using motion signals from ACCL 1604 to determine a gait of user 800 (e.g., from walking and/or running). Those signals may be processed or otherwise analyzed by a gait detection algorithm GAIT DETC 1630, any output from GAIT DETC 1630 may be used in determinations of accelerometry 1454 and/or determinations of the user 800 being awake 1452, for example. GAIT DETC 1630 may output one or more signals and/or data denoted as GAIT 1381. GAIT 1381 may serve as an input to one or more stages of flow 1400, example 1500a, or 1500b. GAIT 1381 may

comprise one of the datum's of FIG. 13 and may be used in present determinations (e.g., stage 1454, 1452 of FIG. 16) related to user 800 and/or future determinations (e.g., as historical data) related to user 800.

[0124] As one example of how signals from one or more sensors in 340 may be relevant to determining TRHR and/or relevant to one or more stages used for determining TRHR of user 800, the stage 1456, which determines if arousal is high (e.g., in user 800's sympathetic nervous system (SNS)), hardware and/or software may receive as inputs, signals from one or more relevant sensors including but not limited to: BIOP 1608; GSR 1610; SNS 1603; EMG 1609; ENV 1617; HR 1601; HRV 1602; I/N/C 1606; IMG 1615 (e.g., micro-expression on face 815 of user 800); TEMPi 1611; and TEMPE 1612.

[0125] As another example, determining of accelerometry is high at the stage 1454 may include one or more relevant sensors and their respective signals including but not limited to: ACCL 1604; GYRO 1605; LOC 1613; HR 1601; and GAIT 1381.

[0126] As yet another example, determining if the user 800 is awake at the stage 1452 may include one or more sensors and their respective signals including but not limited to: RES 1607; HR 1601; HRV 1602; SNS 1603; LOC 1613; GYRO 1605; ACCL 1604; IMG 1615 (e.g., process captured images for closed eyes, motion from rapid eye movement (REM) during REM sleep, micro-expressions, etc.); and GAIT 1381. In the examples above, there may be more of fewer sensors and their respective signals as denoted by 1648, 1646, and 1644. Some of the signals may be derived from signals from one or more other sensors including but not limited to HRV 1602 being derived from HR 1601, LOC 1613 being derived from LOC/GPS 337 signals and/or data, GAIT 1381 being derived from ACCL 1604, for example.

[0127] Processor 310 may execute one or more algorithms (ALGO) 1620 that may be accessed from data storage system 320 and/or an external source to process, analyze, perform calculations, or other on signals from sensors in 340 and/or signals or data from external sensors as described above. Some of the algorithms used by processor 310 may reside in CFG 125. APP 998 in client device 999 and/or applications, software, algorithms executing on external systems such as resource 199 and/or server 560 may process, analyze, and perform calculations or other on signals from sensors in 340 in one or more devices 100. As one example, accurate TRHR determinations may require indications that the user 800 is not experiencing physiological stress or other activity that may affect the mind 800m. Therefore, arousal related sensors and their respective signals (e.g., BIOP, EMG, GSR, SNS) and optionally other biometric signals (e.g., HR, HRV, RES, I/C/N), may be analyzed to determine if a state of the user 800's mind 800m is such that the user 800 is not stressed physiologically (e.g., the user 800 is in a peaceful state of mind and/or body). As another example, accelerometry of the user 800's body may be caused by motion of the user 800 and/or motion of another structure the user 800 is coupled with, such as a vehicle, an escalator, an elevator, etc. Therefore, sensor signals from LOC 1613, ACCL 1604 and/or GYRO 1605, GAIT 1381, may be processed along with one or more biometric signals (e.g., HR 1601, SNS 1603) to determine if accelerometry is due to ambulatory or other motion by the user 800 or to some moving frame of reference, such as a train, that the user 800 is riding in. Therefore, at the stage 1454, if GYRO 1605 and/or ACCL 1604 indicate some

motion of user 800, GAIT 1381 is negligible (e.g., the user 800 is not walking), HR 1601 is consistent with a normal HR for the user 800 when awake and at rest, and LOC 1613 indicates the user 800 is moving at about 70 mph, then accelerometry may not be high and a determination of TRHR may proceed because a large component of the motion may be the train the user 800 is riding in, and motion of the user 800 may be due to slight movements made while sitting and/or swaying motion or others of the train. On the other hand, if the user 800 is slowly riding a bicycle, the movement of the user 800's legs, plus increase HR 1601, signals from GYRO 1605 and/or ACCL 1604, and LOC 1613 may indicate high accelerometry even though user 800 is moving slowly. Accordingly, in the bicycle case, the user 800 although moving slowly is not at rest and TRHT may not be accurately determined. As another example, if user 800 is at home in a relaxing environment and is working to solve a complex technical problem, accelerometry may be low, motion signals may be low, and yet arousal related signals may be high due to heightened mental activity needed to solve the complex technical problem. Accordingly, arousal at stage 1456 may be high as the user 800 is stressed (e.g., not necessarily in a bad way) by the problem solving in a way that affects mind 800m and other physiological parameters of the user 800's body that may manifest as arousal and/or HR, HRV, RES, etc. Therefore, the user 800 may be at rest and not in motion, but rather is stressed and TRHS may not accurately be determined.

[0128] Upon determining TRHR (e.g., in bpm), the data for TRHR may be used to compare with one or more other biometric indicators, arousal indicators, I/C/N indicators, fatigue indicators, or others from sensor system 340 and/or from datum's in FIG. 13, for many purposes including but not limited to coaching the user 800, notifications, and reports, just to name a few. As one example, device 100 may notify user 800 that a quality of the user's sleep was not good this Saturday morning using TRHR and an indication of inflammation by device(s) 100. A sleep history (e.g., 1342 in FIG. 13) of the user 800 may indicate that indications of inflammation have occurred in past Saturday mornings and were not present in the user 800 on Friday's the day before. Coaching of user 800 may comprise alerting the user 800 to activities on Friday (e.g., in the evening after work) that may be causes of the inflammation and a suggested remedy for the inflammation (e.g., drink less alcohol on Friday nights).

[0129] As another example, if the user 800 historically has a HR (e.g., HR 1383 in FIG. 13) after working out of X bpm and the difference between that HR and the TRHR is a delta of  $\Delta=5$  bpm, and recently after working out a delta between the user's HR and TRHR is  $\Delta=12$  bpm, then the 7 bpm difference between the users current workout regime and the users historical work regime may be an indication of overtraining by the user 800. Moreover, I/N/C indicators and/or SNS indicators may confirm that the overtraining has resulted in inflammation, dehydration if the user 800 did not properly hydrate during his/her workout, and increased arousal in the SNS of user 800 due to physical stress and/or injury caused by the overtraining. The overtraining may result in user 800 becoming fatigued, in which case GAIT DETC 1630 may determine the user 800 is slower after the workout because the overtraining may have led to injury or affected user 800's state of mind 800m (e.g., as measured by arousal). IMG DETC 1631 may process image data (e.g., from 369) to detect facial expressions, micro-expression, body posture, or other forms of image data that may be used to determine mental

and/or physical state of user **800**, such as injury and/or fatigue from over training, fatigue caused by other factors, lack of sleep or poor sleep, inflammation (I), contraction (C), just to name a few. Device **100** may notify the user **800** of the overtraining and its indicators (e.g., increased HR, indications of inflammation (I), contraction (C), etc.) and coach the user **800** to drink more fluids to reverse the dehydrations, do fewer repetitions as determined by historical exercise data (e.g., **1338** of FIG. **13**) or to rest for 20 minutes after a hard workout, for example. The foregoing are non-limiting examples of how passive determinations of TRHR (e.g., 24/7 and over extended periods of time) may be used and other scenarios may be possible. Moreover, each determination of TRHR may be accomplished without any action on part of the user **800** and without the user **800** even having knowledge that device **100** is currently parsing relevant sensors, analyzing sensor signals, etc. as part continuing process of passively measuring TRHR. As one example, the user **800** may sit down in chair in a hotel lobby to rest/relax for 15 minutes. During that 15 minutes the user **800** is not asleep, is not stressed, and is still (e.g., low accelerometry). Device(s) **100** may have parsed the relevant sensors and determined a TRHR for the user **800** without the user **800** commanding that action or even being aware of it having occurred. The TRHR that was determined in the 15 minutes may be stored as historical data and/or may replace and/or update a prior TRHR measurement.

[0130] Referring back to FIGS. **8A-8G**, non-limiting examples of when TRHR may be determined by device(s) **100** include but are not limited to: in FIGS. **8B, 8C** and **8F**, the user **800** is not at rest, is in motion, has accelerometry not consistent with being at rest and awake, therefore TRHR may not be determined; in FIG. **8G** where if user **800** is asleep, then user **800** is not awake even thou accelerometry may be consistent with little or no motion, therefore TRHR may not be determined; in FIG. **8G** where if user **800** is awake and resting by lying down, then accelerometry may be consistent with little or no motion and if there are no arousal issues in the SNS, then TRHR may be determined; in FIG. **8E** where if user **800** is awake and resting by sitting down, then accelerometry may be consistent with little or no motion, and if there are no arousal issues in the SNS, then TRHR may be determined; and in FIG. **8D** where if user **800** is awake, and standing, then accelerometry may or may not be consistent with little or no motion, and there may be arousal issues in the SNS, then TRHR may not be determined as standing may not be considered to be a state of resting because some physical activity is required for standing. However, the scenario of FIG. **8D** may also be a corner case where user **800** may be at rest, have low or no accelerometry, and have no arousal issues in the SNS such that this corner case may in some examples allow for a determination of TRHR. As to FIG. **8E**, if user **800** is sitting at rest in a moving object such as a car, train, plane, etc., then low accelerometry, and no arousal issues from the SNS may still allow for a determination of TRHR and data from LOC/GPS **337** may be analyzed to determine that some accelerometry or other motion may be attributed to the vehicle the user **800** is sitting in.

[0131] Attention is now directed to FIG. **17A** where a block diagram of one example **1700a** of sensor platform in a wearable device **100** to passively detect fatigue of a user (e.g., in real-time) that includes a suite of sensors including but not limited to sensor suites **1701-1713**. Devices **100** may include all or a subset of the sensor suites **1701-1713**. Sensor suites

**1701-1713** may comprise a plurality of sensors in sensor system **340** that may be tasked and/or configured to perform a variety of sensor functions for one or more of the suites **1701-1713**. For example, biometric suite **1705** may use one or more of the same sensors as the arousal suite **1701**, such as a GSR sensor. As another example, accelerometry suite **1703** may use one or more motion sensors that are also used by the fatigue suite **1711**. As yet another example, I/C/N suite **1701** may use sensors that are also used by the arousal **1707**, biometric **1705**, and TRHR **1709** suites. Accelerometry suite **1703** may use one or more motion sensors (e.g., accelerometers, gyroscopes) to sense motion of user **800** as translation and/or rotation about X-Y-Z axes **897** as described above. Sensor suites **1701-1713** may comprise one or more of the sensor devices (e.g., **1601-1617**, GAIT **1381**) described above in reference sensor system **340** in FIG. **16**. Sensor suites **1701-1713** may comprise a high-level abstraction of a plurality different types of sensors in device **100** that may have their signals processed in such a way as to perform the function of the name of the suite, such as a portion of the plurality different types of sensors having their respective signals selected for analysis etc. to perform the I/C/N function of determining whether or not user **800** is in an inflammation state, a nominal state or a contracted state, for example. Therefore, a sensor suite may not have dedicated sensors and may combine sensor outputs from one or more of the plurality of different types of sensors in device **100**, for example.

[0132] In FIG. **17B**, one example **1700a** of a wearable device **100** to passively detect fatigue of a user **800** is depicted having a chassis **199** that includes a plurality of sensor suites **1701-1711** positioned at predetermined locations within chassis **199**. For example, sensors for detecting biometric signals related to arousal of the SNS for arousal suite **1707** may be positioned at two different locations on chassis **199**, and those sensors may be shared with other suites such as biometric suite **1705**. There may be more or fewer devices **100, 100i** than depicted as denoted by **1799**. Device **100i** may have different sensor suites than device **100**, such as accelerometry suite **1703**, biometric suite **1705**, and ENV suite **1713**; whereas, device **100** may have all of the suites **1701-1713**, for example. Device **100** and its suites (e.g., arousal **1701**, biometric, accelerometry **1703**, and fatigue **1713**) may be used for passively determining fatigue in user **800**, and may also use data from sensor suites in device **100i** (e.g., accelerometry suite **1703** in **100i**) to aid in its determination of fatigue. Data including sensor signal data may be shared between devices **100** and **100i** via wireless communication link **196**, for example. Data from one or more sensor suites may be wirelessly communicated to an external system such as **199** or **999**, for example. Data from any of the sensor suites **1701-1713** in any of the devices (**100, 100i**) may be internally stored (e.g., in DS **320**), externally stored (e.g., in **1750**) or both. Data may be accessed internally or externally for analysis and/or for comparison to norms (e.g., historically normal values) for the user **800**, such as comparing a current HR of user **800** to historical data for a previously determined TRHR of user **800**.

[0133] In FIG. **17C** one example **1700c** of speed of movement and heart rate (HR) as indicators of fatigue captured by sensors (e.g., one or more sensor suites of FIGS. **17A-17B**) in communication with a wearable device **100** to passively detect fatigue of a user **800** are depicted. Here, sensors used for detecting speed of movement and HR may reside on the device **100**, may reside in another device **100** or both. Speed

of movement **1760** of user **800** may range from slow (e.g., dragging of feet) to fast (e.g., walking briskly, jogging, or running). HR **1770** may range from low to high (e.g., in bpm). For purposes of explanation only, assume device **100** has sensor suites: **1703** for accelerometry; **1705** for biometrics; and **1711** for fatigue. The accelerometry suite **1703** may include the aforementioned motion sensors (e.g., gyroscope, multi-axis accelerometer), and may also access location data and/or GPS data (e.g., **1613**, **1360**) to determine distance travelled, speed by dividing distance traveled by time, or to determine if user **800** is more or less remaining in the same location (e.g., a room). Biometric suite **1705** may include sensors for detecting HR, HRV, respiration (RESP), GSR, EMG or others; however, biometric suite **1705** may also access historical or nominal (e.g., normal) data that may be used for comparing current sensor data with normal data for user **800**. Device **100** may operate to passively determine fatigue in user **800** on a continuous basis (e.g., 24/7) as denoted by clock **1760** and interval **1761** which cycles continuously in 24/7 mode or less if the mode is intermittent (e.g., every two hours).

[0134] Now as for speed of movement **1760**, three examples of how accelerometry sensor data and optionally other data such as location data, time of day, day of the week, and historical/normal values for user **800** may be used to determine whether or not the user **800** is fatigued will be described. In a first example, user **800**'s speed of movement is slow **1763** based on accelerometry data and location data being processed to determine that user **800** is moving slowly at 11:00 am on a Wednesday (e.g., at a time the user **800** is usually walking briskly between college classes). Historical data for the time of day and day of the week (11:00 am and Wednesday) include a range of normal walking speeds for user **800** denoted as "Walking Nom". Device **100** and/or an external system may process the sensor data, nominal historical data, and optionally other data (e.g., biometric data) to determine that a calculated difference between the current speed of **1763** and the historical norms, denoted as  $\Delta 1$  may be large enough to indicate fatigue in user **800**. As another example, if during strenuous physical activity (e.g., athletic training) historically normal values for speed of movement are denoted by "Exertion Nom" and current sensor data indicates speed of movement is fast at **1767**, a calculated difference between the current speed of movement **1767** and the historical norms, denoted as  $\Delta 2$  may be large enough to indicate fatigue in user **800**. In the first example, the indicated fatigue that is causing user **800** to move slower than normal may be due to any number of causes, but as an example, the cause may be mental stress due to studying and may also be due to lack of sleep from staying up late to get the studying done. One or more items of data described above in reference to FIG. 13 may be accessed to determine causation and to provide coaching, avoidance, notifications, reports, etc. For example, the accelerometry suite **1703** may be used to determine length of sleep by analyzing a time difference between motion signals indicating the user **800** has gone to sleep (low accelerometry) and later indicating the user **800** has awoken (higher accelerometry). That time difference may indicate the user **800** got three hours of sleep instead of a normal six hours. Coaching may include recommending getting at least two more hours of sleep, not drinking caffeine right after getting up, and not skipping breakfast. Location data and data on eateries may be used (e.g., see FIG. 13) to determine that the user **800** has not visited the normal locations for breakfast

prior to experiencing the slower movement and may be skipping breakfast due to lack of time to eat. Avoidance may include temporal data having information on dates for exams and instructing the user **800** to sleep at least five hours and eat breakfast several days before exams begin to prevent the user **800** from falling into the prior pattern of inadequate sleep and nutrition during exams.

[0135] In the second example,  $\Delta 2$  may indicate overtraining on part of the user **800** that may affect other body functions, such as HR, HRV, inflammation, etc. As one example, current speed of movement **1767** may have strained a muscle in user **800**'s thigh and lead to systemic inflammation (e.g., the I in I/C/N) and that inflammation has elevated the user **800**'s HR to a current high value of **1773** such that there is a difference between current HR **1773** and the user **800**'s TRHR of "TRHR nom". The normal value for TRHR may be determined as described above and may be stored for later use by devices **100** (e.g., see FIG. 13). Device **100** and/or an external system (e.g., **999**) may determine that  $\Delta 2$  in combination with  $\Delta 3$  are indicative of fatigue in user **800**. Coaching may include recommending user **800** abstain from athletic activities, get rested, and address the indicated inflammation (e.g., strain to thigh muscles). Avoidance may include recommending the user take water breaks and/or rest breaks during the athletic activities as opposed to non-stop exertion from the beginning of the activity to the end.

[0136] The examples depicted are non-limiting and data for normal values or ranges of normal values may be stored for later access by devices **100** and/or external systems to aid in determining fatigue, I/C/N, true resting heart rate, stress, etc. As another example, current speed of movement **1765** when analyzed may not trigger any indication of fatigue as its associated accelerometry is not slow or fast, but somewhere in between, or some other metric such as current HR **1775** being within a normal range for TRHR. Current speed of movement **1765** may be associated with low accelerometry but with a speed that is faster than Walking Nom", and may be an indication that user **800** is riding on public transit and may be sitting down thus giving rise to a HR that is within the normal for TRHR, such that the data taken as a whole does not indicate fatigue.

[0137] Referring now to FIG. 18 where examples **1800a-1800d** of sensor inputs and/or data that may be sourced internally or externally in a wearable device **100** to passively detect fatigue of a user are depicted. Stages depicted in examples **1800a-1800d** may be one of a plurality of stages in a process for passively determining fatigue (e.g., in real-time). Data, datum's, items of data, etc. depicted in FIGS. 13 and 16 may be used for in examples **1800a-1800d**.

[0138] In example, **1800a**, a stage **1810** for passively determining fatigue in a user **800** may comprise data from one or more sensor suites: accelerometry **1703**; biometrics **1705**; TRHR **1709**; fatigue **1711**; and more or fewer suites as denoted by **1812**. Moreover, data **1750** may be accessed (e.g., wirelessly for read and/or write) by one or more devices **100** to make the determination at stage **1810**.

[0139] In example **1800b**, a stage **1820** for passively determining fatigue in a user **800** may comprise data from one or more sensor suites: I/C/N **1701**; accelerometry **1703**; arousal **1707**; fatigue **1711**; ENV **1713**; and more or fewer suites as denoted by **1812**. Furthermore, data **1750** may be accessed.

[0140] In example, **1800c**, a stage **1830** for passively determining fatigue in a user **800** may comprise data from one or more sensor suites: I/C/N **1701**; accelerometry **1703**; biomet-

rics 1705; arousal 1707; TRHR 1709; fatigue 1711; ENV 1713; and more or fewer suites as denoted by 1812. Furthermore, data 1750 may be accessed.

[0141] In example 1800*d*, a stage 1840 for passively determining fatigue in a user 800 may comprise data from one or more sensors: IMG 1615; BIOP 1608; GSR 1610; I/N/C 1606; GAIT 1381; GYRO 1605; LOC 1613; ENV 1617; HRV 1602; EMG 1609; SNS 1603; HR 1601; TEMPi 1611; ACCL 1604; and RES 1607, and more or fewer sensors as denoted by 1814. Furthermore, data 1750 may be accessed. Data 1750 may include one or more of the items of data depicted in FIG. 13. Sensors and/or sensor suites in examples 1800*a*-1800*d* may be accessed, parsed, read, or otherwise in real-time and optionally on a 24/7 basis, for example.

[0142] Turning now to FIG. 19 where one example of a flow diagram 1900 for passively detecting fatigue in a user 800 is depicted. Flow 1900 may be executed in hardware, software or both and the hardware and/or software may be included in one or more of the devices 100 and/or in one or more external devices or systems (e.g., 199, 960, 999). At a stage 1901 sensor relevant to determining a current state of stress (or lack of stress) may be parsed (e.g., have their signal outputs read, sensed, by circuitry in device 100) passively, that is without intervention on part of user 800. At a stage 1903 signals from one or more of the relevant sensors that were parsed may be compared with one or more baseline (e.g., normal or nominal) values (e.g., baseline data) as described above (e.g., in FIG. 17C). The baseline values/data may be from an internal data source, an external data source or both as described above. The comparing may be accomplished in hardware (e.g., circuitry), software or both. The hardware and/or software for the stage 1903 and other stages of flow 1900 may reside internal to one or more devices 100, external to one or more of the devices 100 or both. At a stage 1905 a determination may be made as to whether the comparison at stage 1903 is indicative of fatigue (e.g., chronic stress) in user 800. If a NO branch is taken, then flow 1900 may transition to another stage, such as a stage 1921, for example. If a YES branch is taken, then flow 1900 may transition to a stage 1907. At the stage 1907 one or more causes for the indicated fatigue may be determined using one or more items of data and/or sensor signals described herein, such as describe above in reference to FIGS. 9-11 and 13-18, for example.

[0143] At a stage 1909 a decision may be made as to whether or not the determined cause(s) may require applying coaching. If a YES branch is taken, then flow 1900 may transition to a stage 1911 were coaching data (e.g., ASCII text, HTML, XML, SMS, email, digital audio file, or other format of data) may be communicated to user 800, a client device (e.g., 999), one or more devices 100 (e.g., see 501 in FIG. 5) or external device or system. Flow 1400 may transition from stage 1911 to a stage 1913 as will be described below, so that application of avoidance may be decided based on the determined cause(s) at the stage 1907. If a NO branch is taken, then flow 1900 may transition to the stage 1913.

[0144] At the stage 1913 a decision may be made as to whether or not the determined cause(s) may require applying avoidance. If a YES branch is taken, then flow 1900 may transition to a stage 1915 were avoidance data (e.g., ASCII text, HTML, XML, SMS, email, digital audio file, or other format of data) may be communicated to user 800, a client device (e.g., 999), one or more devices 100 (e.g., see 501 in FIG. 5) or external device or system. If a NO branch is taken, flow 1900 may transition to a stage 1917 were a determination

may be made as to whether or not the user 800 has complied with the coaching (if generated), the avoidance (if generated) or both. If a NO branch is taken (e.g., compliance of user 800 is not detected), flow 1900 may transition to another stage, such as the stage 1909, where the analysis for coaching and/or avoidance may be repeated. If a YES branch is taken (e.g., compliance of user 800 is detected), then flow 1900 may transition to a stage 1919.

[0145] At the stage 1919 a determination may be made as to whether or not the results of user compliance at the stage 1917 have been efficacious, that is, has fatigue (e.g., stress) been reduced or eliminated (e.g., as determined by sensors in device(s) 100, etc.). If a NO branch is taken, then flow 1900 may transition to a stage 1921 where one or more data bases may be updated using data from any of the stages of flow 1900 that may relevant to improving results in future interactions of flow 1900. At a stage 1923, a different set or sets of data may be selected from the data base and flow 1900 may transition to another stage, such as the stage 1907 to re-determine the cause(s) of the fatigue. If a YES branch is taken at the stage 1919, then flow 1900 may transition to a stage 1925 where a determination may be made as to whether or not fatigue detection is completed (e.g., is flow 1900 done?). If a YES branch is taken, then flow 1900 may terminate. If a NO branch is taken, then flow 1900 may transition to a stage 1927 were a determination to continue flow 1900 may be made. If a YES branch is taken, then flow 1900 may transition to another stage, such as the stage 1901, for example. Flow 1900 may continuously execute on a 24/7 basis or in some interval, such as every 10 minutes, for example.

[0146] If a NO branch is taken from the stage 1927, then flow 1900 may transition to another flow as denoted by 1929. For example, off-page reference 1929 may represent another flow for determining other activity in body of user 800, such as the flow 1000 of FIG. 10, the flow 1400 of FIG. 14, the flow 1500*a* and/or 1500*b* of FIGS. 15A and 15B, for example. As one example, the NO branch from the stage 1927 may transition to flow 1000 for determination of I/C/N and flow 1000 may transition to flow 1400 for determination of TRHR, and then flow 1400 may transition to flow 1900 for determination of fatigue, on so on and so forth. The flows described herein may execute synchronously, asynchronously, or other on one or more devices 100 and execute in sequence, or in parallel.

[0147] Although the foregoing examples have been described in some detail for purposes of clarity of understanding, the above-described inventive techniques are not limited to the details provided. There are many alternative ways of implementing the above-described techniques or the present application. Waveform shapes depicted herein are non-limiting examples depicted only for purpose of explanation and actual waveform shapes will be application dependent. The disclosed examples are illustrative and not restrictive.

What is claimed is:

1. A wearable device, comprising:

- a ring operative to be donned on a digit of a hand or on a toe of a foot, the ring including
  - one or more radios operative for wireless communication using one or more wireless protocols,
  - pressure sensors disposed on the ring and operative to generate first signals indicative of pressure applied by body tissue coupled with the pressure sensors when the ring is donned,
  - a motion sensor operative to generate a motion signal generated by motion of the ring when donned, and

biometric sensors operative to generate biometric signals when the ring is donned, the biometric signals including an arousal signal indicative of arousal in a sympathetic nervous system (SNS); and

a processor operative to analyze the first signals and the motion signal to determine motion induced error in the first signals caused by the motion of the ring when donned, to subtract out the motion induced error, if present in the first signals, using the motion signal, and to generate a state signal indicative of an inflammation (I) state, a contraction (C) state, or a nominal (N) state of the body tissue,

the processor operative to analyze the biometric signals and the state signal, to communicate information relevant to a sleep state when the motion signal, the arousal signal or both indicate sleep and the state signal indicates the I state, the C state, or the N state.

2. The wearable device of claim 1, wherein the ring includes a display operative to present at least a portion of the information that is relevant to the sleep state.

3. The wearable device of claim 1, wherein the information is wirelessly communicated to a wireless client device using the one or more radios.

4. The wearable device of claim 1, wherein the information comprises one or more types of information selected from the group consisting of a report, coaching, a notification, avoidance, and a mood.

5. The wearable device of claim 1, wherein an interior portion of the ring includes a plurality of dimples that are coupled with the body tissue when the ring is donned, and each dimple including one of the pressure sensors.

6. The wearable device of claim 1, wherein the pressure sensors are positioned adjacent to at least one slot or spiral formed in the ring and operative to couple with body tissue that enters the at least one slot or spiral.

7. The wearable device of claim 1, wherein the biometric sensors comprise a plurality of sensors selected from the group consisting of a heart rate sensor, a respiration sensor, a temperature sensor, a skin conductance sensor, a skin conductance response sensor, a galvanic skin response (GSR) sensor, an electromyography (EMG) sensor, an electrodermal activity sensor, and an electrodermal response sensor.

8. The wearable device of claim 1, wherein the processor is disposed in a system external to the ring, the first signals, the motion signal, and the biometric are wirelessly communicated to the processor using a wireless link between the system and the one or more radios.

9. The wearable device of claim 1, wherein the processor accesses external data that is relevant to the sleep state, and the external data comprises one or more datum selected from the group consisting of true resting heart rate (TRHR), heart rate variability (HRV), fatigue data, location data, diet data, almanac data, health data, and exercise data.

10. The wearable device of claim 1, wherein the processor is included in the ring.

11. The wearable device of claim 1, wherein the information is wirelessly communicated to an external resource.

12. The wearable device of claim 1, wherein the ring includes a rigid structure and a deformable structure, the deformable structure is coupled with the body tissue when the ring is donned and the pressure sensors are coupled with a portion of the deformable structure, the deformable structure operative to compress when the body tissue expands and operative to relax when the body tissue contracts, and wherein

the first signals are indicative of the deformable structure being compressed, relaxed, or not compressed or relaxed.

13. The wearable device of claim 1, wherein the ring includes one or more openings with each opening including one of the pressure sensors positioned in it and coupled with the ring on opposite sides of the opening, an interior portion of the ring is coupled with the body tissue when the ring is donned, the ring expanding at the one or more openings when the body tissue expands, the ring contracting at the one or more openings when the body tissue contracts, and wherein the first signals are indicative of the ring expanding at the one or more opening, contracting at the one or more openings, or not expanding or contracting at the one or more openings.

14. The wearable device of claim 1, wherein the ring includes a flexible structure that is coupled with the body tissue when the ring is donned, and the pressure sensors are coupled with the flexible structure, the flexible structure expanding when the body tissue expands, the flexible structure contracting when the body tissue contracts, and wherein the first signals are indicative of the flexible structure expanding when the body tissue expands, the flexible structure contracting when the body tissue contracts, or the flexible structure not expanding or not contracting.

15. A wearable mood device, comprising:

a ring including

a mood display,

one or more radios operative for wireless communication using one or more wireless protocols,

pressure sensors disposed on the ring and operative to generate first signals indicative of pressure applied by body tissue coupled with the pressure sensors when the ring is donned,

a motion sensor operative to generate a motion signal generated by motion of the ring when donned, and

biometric sensors operative to generate biometric signals when the ring is donned, the biometric signals including an arousal signal indicative of arousal in a sympathetic nervous system (SNS); and

a processor coupled with the mood display, the processor operative to analyze the first signals and the motion signal to determine motion induced error in the first signals caused by the motion of the ring when donned, to subtract out the motion induced error, if present in the first signals, using the motion signal, and to generate a state signal indicative of an inflammation (I) state, a contraction (C) state, or a nominal (N) state of the body tissue, and

the processor operative to analyze the biometric signals and the state signal, to communicate information relevant to a sleep state when the motion signal, the arousal signal or both indicate sleep and the state signal indicates the I state, the C state, or the N state and operative to generate a mood signal that presents the sleep state as one of a plurality of different moods on the mood display.

16. The wearable mood device of claim 15, wherein the mood display includes a plurality of discrete visual display elements, each visual display element when activated is associated with only one of the plurality of different moods.

17. The wearable mood device of claim 15, wherein the mood display is operative to indicate the I state, the C state, or the N state.

18. The wearable mood device of claim 15, wherein the mood display comprises an optoelectronic device.

**19.** The wearable mood device of claim **15**, wherein the mood signal is wirelessly transmitted from the ring to a wireless client device that is wirelessly linked with the one or more radios in the ring.

**20.** The wearable mood device of claim **15**, wherein the ring is donned on a digit of a hand.

\* \* \* \* \*

专利名称(译)	可穿戴式戒指，用于睡眠监测		
公开(公告)号	<a href="#">US20150182164A1</a>	公开(公告)日	2015-07-02
申请号	US14/246971	申请日	2014-04-07
[标]申请(专利权)人(译)	说出II MAX EVERETT		
申请(专利权)人(译)	乱说，II，MAX EVERETT		
当前申请(专利权)人(译)	Alifak		
[标]发明人	UTTER II MAX EVERETT		
发明人	UTTER, II, MAX EVERETT		
IPC分类号	A61B5/00 A61B5/04 A61B5/053 A61B5/0488 A61B5/11 A61B5/0205		
CPC分类号	A61B5/4842 A61B5/0022 A61B5/1107 A61B5/0205 A61B5/681 A61B5/0533 A61B5/0488 A61B5/04001 A61B5/053 A61B5/002 A61B5/02055 A61B5/1072 A61B5/1112 A61B5/1123 A61B5/165 A61B5/6826 A61B5/6831 A61B5/7275 A61B2503/10 A61B2505/07 G16H15/00 G16H20/30 G16H40/63 G16H40/67 A61B5/0004 A61B5/01 A61B5/02405 A61B5/08 A61B5/4809 A61B5/4812 A61B5/4866 A61B5/6843 A61B5/721 A61B5/7282 A61B5/742 G01L1/00		
外部链接	<a href="#">Espacenet</a>	<a href="#">USPTO</a>	

摘要(译)

可佩戴环（例如，在手的手指和/或脚的脚趾上）可以包括用于响应于用户的身体运动产生运动信号的传感器，用于响应于身体部分施加的力产生力信号，用于产生指示身体中的生物特征活动的生物特征信号（例如，心率，呼吸，唤醒），以及用于基于用户位置生成位置信号。可以处理传感器信号以监测可能对用户的睡眠状态产生正面或负面影响的参数（例如，睡眠时间，睡眠质量，水合作用，炎症，收缩，疲劳，TRHR，加速度测量，SNS唤醒，等等。）。从处理的信号导出的数据可以以旨在指示的格式（例如，报告，通知，指导，回避，情绪）呈现给用户（例如，视觉，声音，电子邮件，文本消息，触觉，网页等）。鼓励用户改善他们的睡眠状态。

