



(19) **United States**

(12) **Patent Application Publication**  
**Olsen**

(10) **Pub. No.: US 2013/0211214 A1**

(43) **Pub. Date: Aug. 15, 2013**

(54) **CONFIGURABLE PATIENT MONITORING SYSTEM**

*A61B 5/145* (2006.01)

*A61B 5/0205* (2006.01)

*A61B 5/026* (2006.01)

*A61B 5/1455* (2006.01)

(71) Applicant: **Cercacor Laboratories, Inc., (US)**

(72) Inventor: **Gregory A. Olsen, Trabuco Canyon, CA (US)**

(52) **U.S. Cl.**

CPC ..... *A61B 5/743* (2013.01); *A61B 5/0261* (2013.01); *A61B 5/14552* (2013.01); *A61B 5/14546* (2013.01); *A61B 5/14532* (2013.01); *A61B 5/02055* (2013.01); *A61B 5/01* (2013.01); *A61B 5/7282* (2013.01); *A61B 5/746* (2013.01); *A61B 5/7405* (2013.01); *A61B 5/0008* (2013.01)

(73) Assignee: **CERCACOR LABORATORIES, INC., Irvine, CA (US)**

(21) Appl. No.: **13/762,751**

USPC ..... **600/316**; 600/476; 600/480; 600/479; 600/323; 600/322; 600/324

(22) Filed: **Feb. 8, 2013**

**Related U.S. Application Data**

(60) Provisional application No. 61/597,140, filed on Feb. 9, 2012.

(57)

**ABSTRACT**

A patient monitoring system can display one or more configurable health monitors on a configurable user interface. The health indicators are configured to display a physiological signal from a patient. The patient monitoring system can calculate ranges of values for the health indicator that correspond to a status of the patient. The health indicators can display different outputs based on the value of the physiological signal.

**Publication Classification**

(51) **Int. Cl.**

*A61B 5/00* (2006.01)

*A61B 5/01* (2006.01)

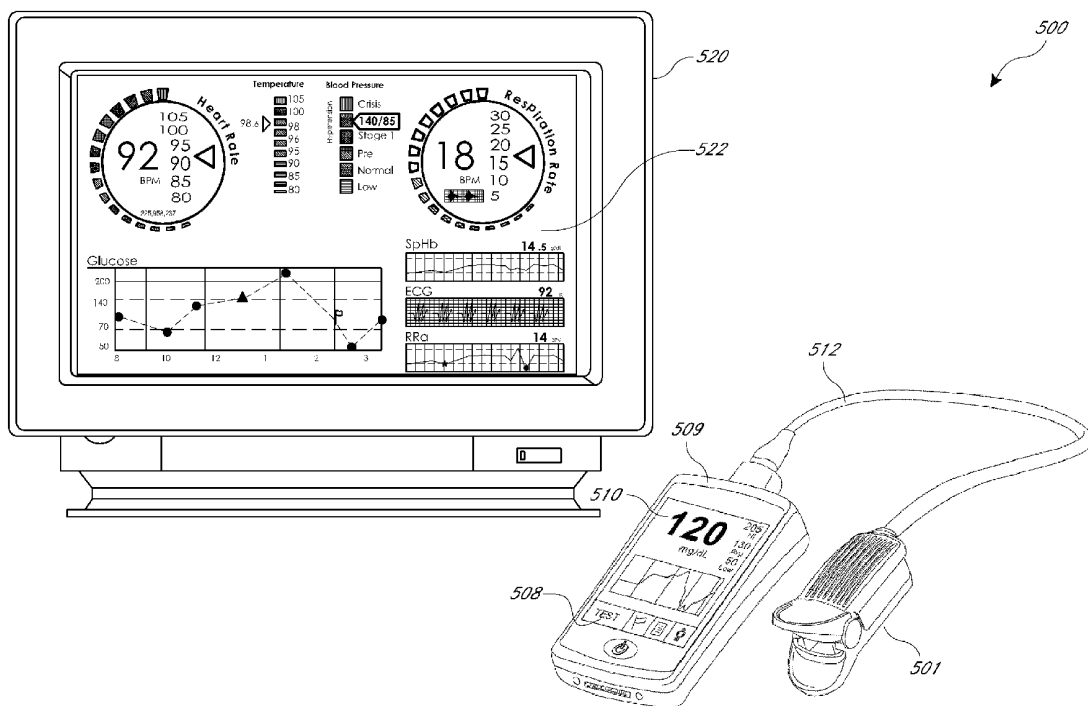

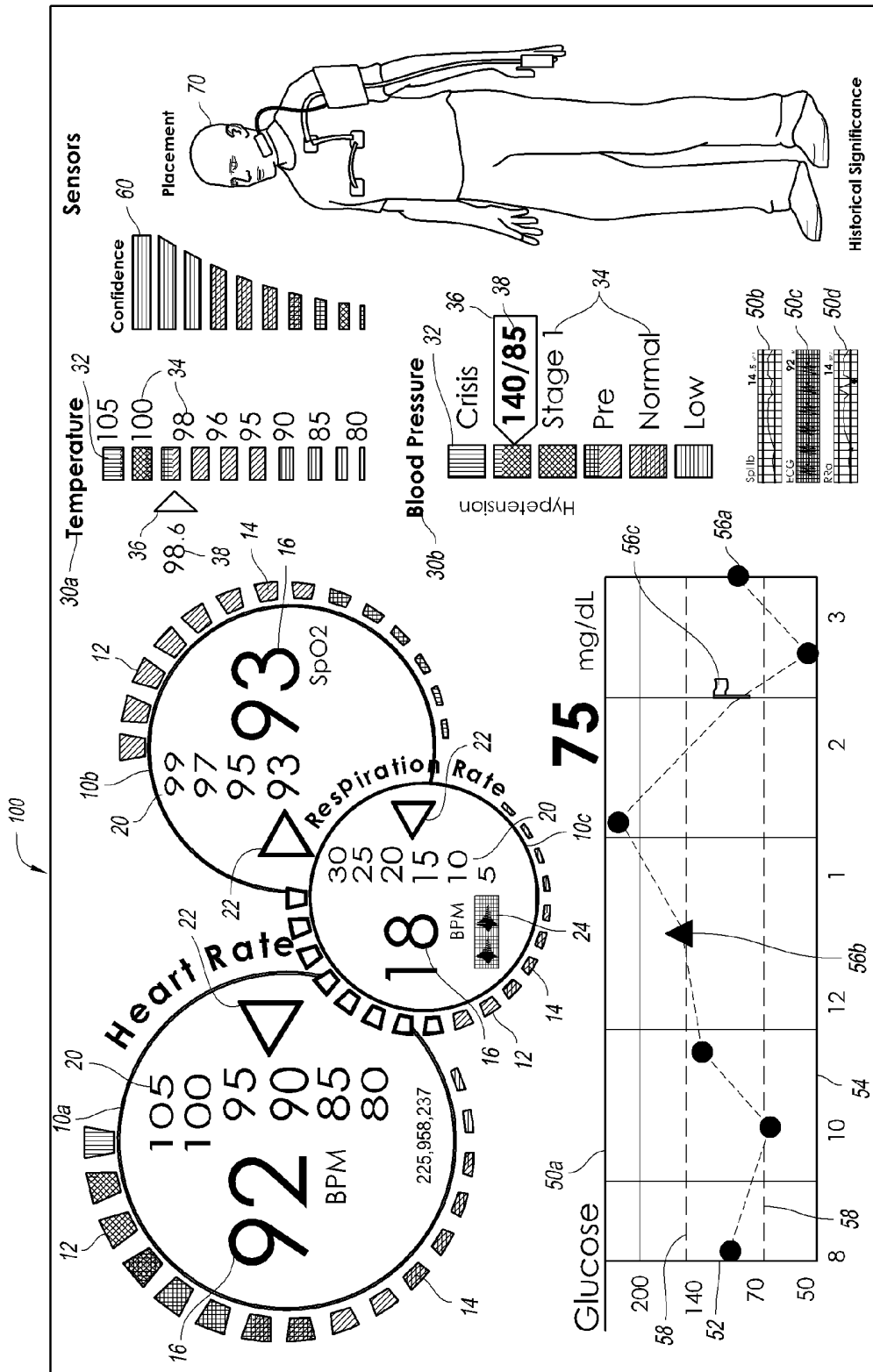

FIG. 1

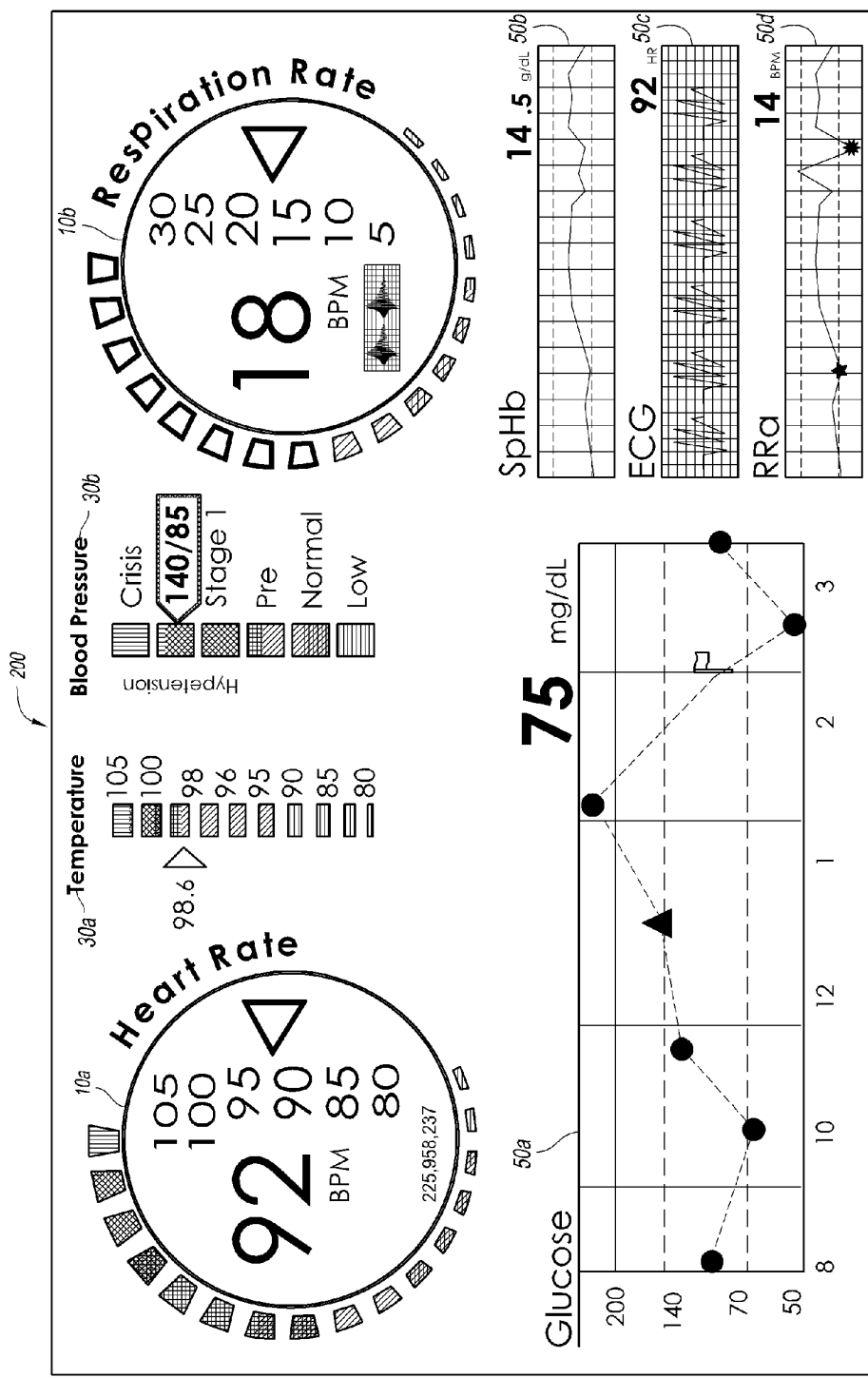

FIG. 2

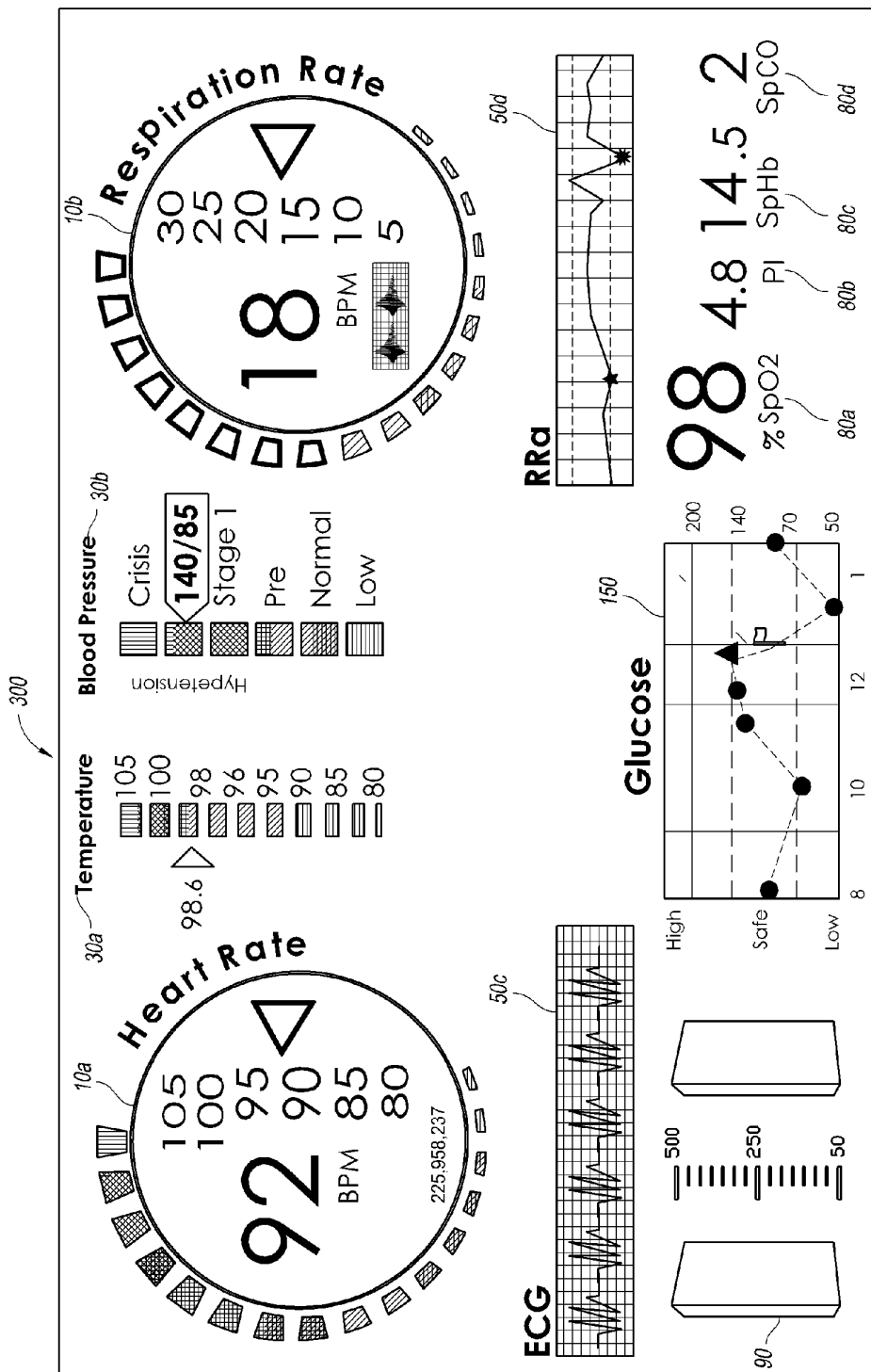

FIG. 3

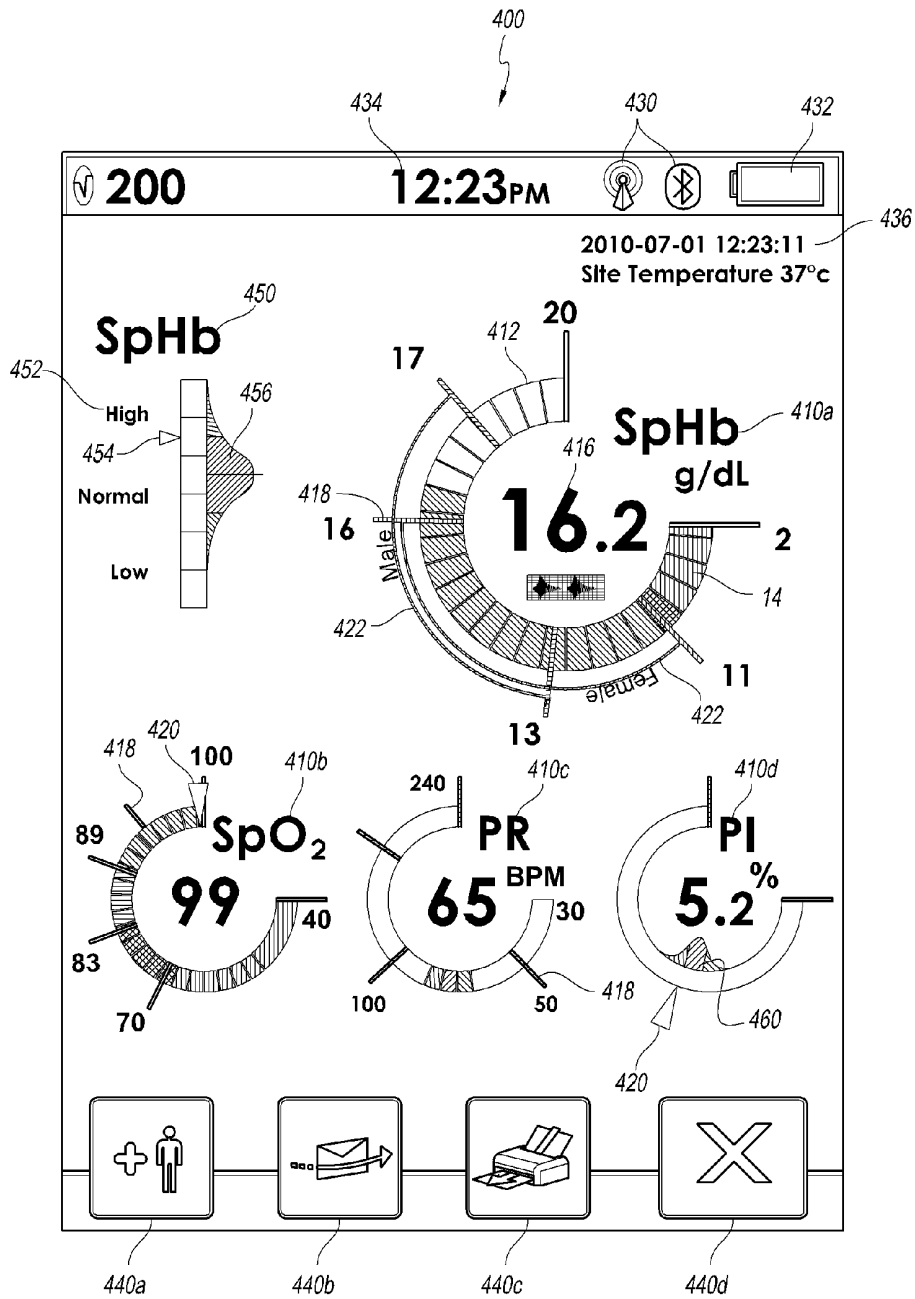

FIG. 4

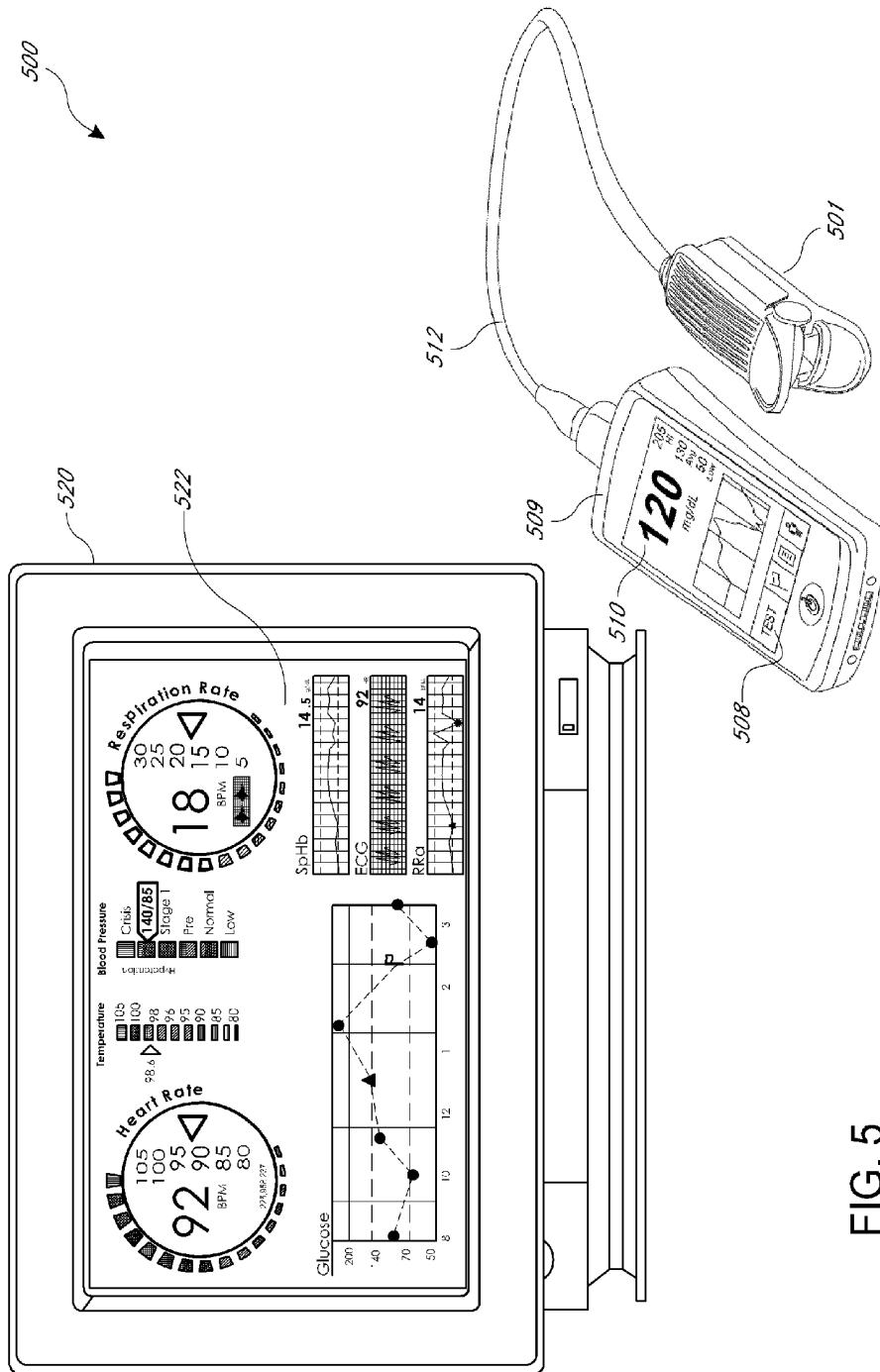

FIG. 5

## CONFIGURABLE PATIENT MONITORING SYSTEM

### CROSS-REFERENCE TO RELATED APPLICATIONS

**[0001]** This application claims priority to U.S. Application No. 61/597,140, filed Feb. 9, 2012, titled PATIENT MONITOR, the entire contents of which are incorporated by reference herein and made a part of this specification.

### BACKGROUND

**[0002]** 1. Field of the Invention

**[0003]** The present disclosure relates to the field of patient monitoring systems.

**[0004]** 2. Description of the Related Art

**[0005]** Patient monitoring systems are used to track and monitor the health and wellness of a patient. A patient's health can be monitored using physiological sensors to record and process a patient's vital signs, such as, pulse rate, temperature, glucose level, and other physiological parameters. A medical practitioner can use this information to track the health of a patient. Each patient has different physiological characteristics, such as gender, age, weight, height, fitness, medical history, and other characteristics, which can affect the range of signals that are considered healthy for each person. For example, the normal resting heart rate for an athlete may be close to fifty beats per minute, whereas for another adult, the normal resting heart rate may be closer to one hundred beats per minute. As such it can be difficult for medical practitioners to quickly evaluate the health of the patient without consulting additional information prior to analyzing the patient's physiological signals, which can be a time consuming process. In some cases, a patient's physiological signals may appear healthy, even though the patient is in need of medical attention. Additional, typical sensors only display the current value for a patient's physiological sensors, which can make it difficult for a medical practitioner to identify trends in the patient's health.

### SUMMARY

**[0006]** Patient monitoring systems can help health practitioners to quickly evaluate a patient's state of health and wellness by providing health indicators that help differentiate between healthy and unhealthy signals. Indicators that are easy to see and understand quickly are critical in the patient care industry. Even more important are indicators that can be readily understood by less educated care providers and by those that speak and/or read a different language than the device displays. In some embodiments of this disclosure, customized health indicators can be configured to account for a patient's specific physiological parameters, including medical history, current medications, and other health considerations. These customizations can assist in the quick recognition of potential problems by the less educated and foreign language observers. In some embodiments, the health indicators can be configured to show the signal over a period of time, which can help a medical practitioner identify how the patient's health is trending.

**[0007]** In one embodiment, a patient monitoring system has a first physiological sensor that is configured to measure at least one physiological signal from a patient. A health indicator is configured to display a signal value based on the output of at least one physiological signal. The patient moni-

toring system is configured to receive patient information and calculate a first range of values and a second range of values for the health indicator. The first range of values corresponds to a first range of physiological signals from the patient and to a healthy patient condition. The second range of values corresponds to a second range of physiological signals from the patient and to an unhealthy patient condition. In some embodiments the calculated ranges can be based at least in part on patient information. The patient monitoring system also has a user interface configured to display the health indicator. The health indicator is configured to display a first output when the signal value is within the first range of values and the health indicator is configured to display a second output when the signal value is within the second range of values.

**[0008]** In some embodiments the patient monitoring system is further configured to calculate a third range of values for the health indicator. The third range of values corresponds to a third range of physiological signals from the patient and corresponds to an intermediate patient condition. In some embodiments, the first, second, and the third ranges of values can overlap.

**[0009]** In some embodiments the health indicator is configured to output an alarm signal when the signal value moves from the first range of values to the second range of values. The alarm signal can be an audible alarm, an electronic message, a visual alarm, or other type of alert system. The patient monitoring system can be configured to communicate with remote devices.

**[0010]** In some embodiments, the first output can be a first color displayed on the health indicator. The second output can be a second color displayed on the health indicator. The first output and the second output can both be displayed when the signal value is in the second range of values.

**[0011]** In some embodiments, the patient information can be age, gender, medical history, or other information about the patient. The health indicator can be number of different indicators such as, a circular indicator, a vertical bar indicator, a trend graph indicator, a Gaussian trend indicator, combinations of the one or more indicators, or other types of indicator. The signal value can be a point on a trend graph, a numeric value, an analog indicator, or other type of representation of the physiological signal value. The physiological sensor can be configured to measure glucose, blood pressure, pulse rate, respiration rate, oxygen saturation, total hemoglobin, carboxyhemoglobin, methemoglobin, perfusion index, temperature, or other physiological parameter. The physiological sensor can be a pulse oximeter, a heart rate monitor, respiratory monitor (e.g., an acoustic monitor), a thermometer, or other physiological sensor.

**[0012]** An embodiment of a method of monitoring a patient has the steps of measuring at least one physiological signal from a patient using a physiological sensor, providing a first health indicator having a signal value based upon the at least one physiological signal, receiving patient information, and calculating a first range of values for the health indicator. The first range of values corresponds to a first range of physiological signals from the patient and to a first patient condition. The method also includes calculating a second range of values for the health indicator. The second range of values corresponds to a second range of physiological signals from the patient and to a second patient condition. The method also includes displaying the first health indicator on a user interface. The first range of values and the second range of values are dis-

played on the first health indicator. The method also includes displaying the signal value on the first health indicator, displaying a first output on the health indicator when the first value is within the first range of values, and displaying a second output on the health indicator when the second value is within the second range of values.

[0013] In some embodiments the method includes the step of displaying a threshold indicator separating the first range of values from the second range of values.

#### BRIEF DESCRIPTION OF THE DRAWINGS

[0014] FIG. 1 is an embodiment of a user interface showing a plurality of health indicators.

[0015] FIG. 2 is another embodiment of a configuration of user interface showing a plurality of health indicators.

[0016] FIG. 3 is another embodiment of a configuration of a user interface showing a plurality of health indicators.

[0017] FIG. 4 is another embodiment of a user interface showing a plurality of health indicators.

[0018] FIG. 5 illustrates an embodiment of an exemplary handheld monitor having a display and an exemplary non-invasive optical sensor of a patient monitoring system.

#### DETAILED DESCRIPTION

[0019] A patient monitoring system can display one or more of a patient's physiological parameters using one or more configurable health indicators on a configurable user interface. Each health indicators can display one or more physiological parameters of the patient. The health indicators can be configured to be easy to read and interpret. The health indicators can include one or more thresholds that can help medical practitioners to evaluate the health and wellness of a patient. The patient monitoring system can display health indicators for a patient's physiological parameters, including heart rate, respiration rate, oxygen saturation (SpO<sub>2</sub>, % SpO<sub>2</sub>), temperature, blood pressure, total hemoglobin (SpHb), perfusion index (PI), carboxyhemoglobin (SpCO), methemoglobin, and other physiological parameters. The physiological signals displayed in each health indicator can be represented by one or more analog indicators and/or one or more digital indicators. The health indicators can be a variety of types including a trend graphs, Gaussian trend graphs, circle indicators, arc indicators, bar indicators, line indicators, and/or other types of indicators. In some embodiments, a health indicator can combine one or more physiological parameters as part of a single health indicator. The displayed values for the health indicators can be derived from sensor signals taken from a patient. For example, pulse rate, blood pressure, and respiration rate can be normalized and combined to determine an overall health indicator. Physiological sensors capable of reading physiological signals are available from healthcare products manufacturers, such as Masimo Corporation located of Irvine, Calif. An example of a physiological sensor and patient monitor is illustrated in FIG. 5.

[0020] A user interface of the patient monitoring system can be configured to display the health indicators. The user interfaces can be customized for each patient. The user interface of the patient monitoring system can provide a centralized display of a patient's health and wellness information. In some embodiments, the patient monitoring system can be configured to display all of and the information associated with the patient on a single display console. In some embodiments the user interface can be displayed on a plurality of

display consoles. Each screen of the user interface can be configured to display one or more health indicators and other information associated with the patient. In some embodiments the health indicators can be configured to be displayed on a handheld display or handheld patient monitor.

[0021] The user interface is configurable and can be configured individually for each patient. A user can configure the user interface. In some embodiments the patient monitoring system can configure the user interface. In some embodiments, the user interface can be generated automatically based on the physiological sensors connected to the patient monitoring system. In some embodiments, the user interface can be configured using a template and/or preconfigured health indicators. Preconfigured user interfaces and health indicators can be further configured and adjusted by the user. The health indicators may include both analog and digital indicators. The analog and digital indicators can be positioned in any number of formations, such as side-by-side, above, below, transposed, etc. The number, type, and arrangement of the health indicators displayed can be determined by various factors, including, the number of physiological sensors, the type of physiological sensors, the settings of the user interface, the hardware configuration, the software configuration, and other factors. Embodiments of user interfaces are illustrated in FIGS. 1 through 4.

[0022] Analog and digital indicators can display measurements of physiological parameters. The indicators can indicate an actual level or a normalized level. The user interfaces can also display information, such as network connection status, network connection strength, network type, power levels, battery power, time, patient identifying information, health provider information, sensor signal confidence levels, sensor placement, and other information.

[0023] In some embodiments a user interface can be configured to display health indicators for each physiological sensor connected to a patient. In some embodiments, a plurality of user interface screens can be configured to display a patient's health information. The user interface screens can be displayed on one or more display consoles. The patient monitoring system can be configured to transfer the signal information to a remote source over a network. In some embodiments the user interface information can be displayed and formatted for viewing on portable computing device, such as a laptop computer, a mobile phone, a tablet computer, and/or other computing device.

[0024] FIGS. 1 through 4 illustrate embodiments of configurable user interfaces.

[0025] FIG. 1 is an embodiment of user interface 100 displaying a plurality of analog and digital health indicators. The user interface 100 includes health indicators for heart rate 10a, respiration rate 10b, oxygen saturation (SpO<sub>2</sub>) 10c, temperature 30a, blood pressure 30b, glucose 50a, total hemoglobin (SpHb) 50b, ECG 50c, and respiration rate (RRa) 50d. The user interface 100 also includes sensor confidence 60, and sensor placement 70 indicators.

[0026] The user interface 100 has three circular health indicators for heart rate 10a, respiration rate 10b and oxygen saturation (SpO<sub>2</sub>) 10c. The circular health indicators have shaped blocks 12 arranged circumferentially around the circular indicator. The blocks 12 increase in size from smaller to larger about the circle. The blocks 12 can illuminate as the value of the measured physiological parameter increases. In some embodiments the blocks display a muted color for each block 12 when the block 12 is not illuminated, such as in

indicators **10a** and **10c**. In some embodiments, the blocks **12** can be clear or display a background color when not illuminated, as in **10b**. In some embodiments an arrow or other measurement indicator can point to a specific value on the indicator.

**[0027]** A color pattern **14** can be associated with the blocks **12**. The color pattern **14** can be configured to indicate patient wellness. The colors of the blocks **12** can help medical practitioners to quickly and easily determine the current status of the physiological parameter. In one embodiment, green can indicate a healthy or normal condition, yellow can indicate deteriorating conditions, and red can indicate critical or severe conditions. In some embodiments, other colors can be used to indicate patient wellness. In some embodiments the blocks **12** can gradually change color around the entire circle moving through blue, green, yellow, orange and, and red, where each block **12** can have one or more colors, as illustrated by patterns **14** on the heart rate indicator **10a**. In some embodiment each block **12** can have a discrete color, as illustrated by the color patterns **14** on indicator **10c**. In some embodiments, red can be used to indicate that a value is too high or too low. In some embodiments, other colors can be used to indicate when the measurements are too low or too high.

**[0028]** In some embodiments, a numeric indicator **16** can be displayed within the circular indicator **10a-c**. A measurement unit, such as BPM, can be associated with the numeric indicator. The numeric value **16** indicates the current measurement of the physiological sensor. In some embodiments the numeric value **16** can be colored to match the color of the associated blocks **12**. In some embodiments the numeric value can be colored to match a color typically associated with the physiological parameter. In some embodiments, the circular indicators **10a-c** can include time based data **24**, such as a respiration auditory waveform or a plethysmograph. The time based data **24** can display the measured signal over a period of time and/or a specific number of measurements.

**[0029]** In some embodiments, the circular indicators **10a-c** can include dial indicators **20**. The numbers of the dial **20** can move past a stationary pointer **22**, such as an arrow. The pointer **22** indicates the current measurement of the physiological sensors, similar to numeric value **16**. The dial **20** can scroll up and down to indicate the current value. In some embodiments the pointer **22** can move up and down to indicate the current measurement. In some embodiments the numbers of the dial **20** and/or the arrow **22** may be colored to indicate the level of patient wellness, similar to blocks **12**.

**[0030]** The user interface **100** has vertical bar indicators, temperature **30a** and blood pressure **30b**. The bar indicators **30a-b** have a plurality of bars **32**, descriptors **34**, a measurement indicator **36**, and a measured value **38**. The bars **32** can have a color pattern **14**. In some embodiments, the bars **32** can be implemented as dots, dashes, arrow, rectangles, squares, or the like. The indicators **30a-b** can have descriptors **34**, such as numbers, words, or symbols relating to the measured condition. The measurement pointer **36** can move up and down along the vertical scale to indicate the current measurement of the physiological sensors. In some embodiments, the bars can scroll through the values and the pointer **36** can remain stationary. The pointer **36** can be implemented using other shapes such as an arrow, circle, star, line or other shape. A measured value **38** can be associated with the pointer **36**. The indicator **36** and/or the measured value **38** can be colored to indicate the level of patient wellness. In some embodiments

the bars and/or descriptors can illuminate or flash based on the occurrence of an event, such as an alarm.

**[0031]** The temperature indicator **30a**, in this embodiment, has numeric descriptors **34** with an arrow-shaped pointer **36**. The pointer **36** moves up and down the bars **32** to indicate the current temperature value. The measured value **38** shows a numeric value for the current measurement of the patient's temperature.

**[0032]** The blood pressure indicator **30b**, in this embodiment, has a plurality of bars **32**, with each bar **32** associated with a text descriptor **34**. The descriptors **34** indicate conditions relating to blood pressure measurements, including stages of hypertension. The pointer **36** is a block arrow with a value **38** showing the current blood pressure measurement. Each bar **32** has an associated range of measurement values. The pointer **36** moves discretely between bars. The pointer **36** only moves between bars **32** when an upper or lower threshold has been surpassed.

**[0033]** The user interface **100** also includes sensor information, such as sensor confidence indicators **60** and sensor placement indicators **70**. The sensor confidence indicator **60** can display the strength and integrity of the sensor signal. In this embodiment the sensor confidence indicator is a vertical bar chart with bars illustrating the relative strength of the sensor signals. In some embodiments the indicator can be color coded. In some embodiments there can be a sensor confidence indicator for each sensor. Sensor confidence indicators can be used to provide information for any of the sensors used by the patient monitoring system.

**[0034]** The sensor placement indicator **70** shows the relative placement of each sensor on the patient. The sensor placement indicator shows an illustration of the patient with the positioning of each sensors connected to the patient. The illustration can change to match the characteristics of the actual patient (e.g., man, woman, child, elderly, etc.). The indicator can display the recommended or expected placement of the sensor on the patient. In some embodiments, the sensor placement indicator can show the actual position of the sensor(s) on the patient.

**[0035]** The user interface **100** also includes trend graphs to show physiological parameter measurements over time, such as glucose **50a**, total hemoglobin (SpHb) **50b**, ECG, **50c**, and respiration rate (RRa) **50d**. The trend indicators can help to identify trends in a patient's health, such as when a patient is moving from a healthy condition toward an unhealthy condition. Trends in the patient's measurements can be shown by displaying physiological measurements over a period of time. Trend graph **50a** includes a vertical axis **52**, a horizontal axis **54**, a measurement indicator **56**, and threshold levels **58**. The trend graph **50a** shows measurements of the physiological parameters over a defined time period. The vertical axis **52** indicates the magnitude of the measurement and the horizontal axis **54** indicates time. In some embodiments the vertical and horizontal axes may not have values displayed. In some embodiments, the current value of the physiological parameter can be displayed on the upper right side of the trend graph.

**[0036]** The measurements can show discrete measurements with continuous measurements in real-time. In some embodiments, the measurement indicator **56** can be used to provide additional information about the measurement data. For example, a circle indicator **56a** can indicate discrete non-invasive measurements and a triangle indicator **56b** can indicate a discrete invasive measurement. Other shapes, such as a

flag indicator **56c**, can be used to show other conditions and/or measurements. In some embodiments, an indicator **56** can be used to show when a measurement has exceeded an upper or lower threshold. The type of measurement indicator **56** can be used to indicate a severe or critical condition based on multiple measurements from different physiological parameters. For discrete measurements, connecting lines, such as a dashed line, may be added between measurements to better visualize the trends of the measurements. For real-time or continuous measurements the information can be shown as a solid line. In some embodiments, the most recent or current value may be displayed above the graph. Threshold levels **58** may be shown on the trend graph. The threshold levels **58** can indicate upper and/or lower thresholds, such as in **50a**, **50b**, and **50d**. The threshold levels **58** may be accompanied by threshold descriptors, as illustrated by the trend graph **150** in FIG. 3. Trend graphs **50b-d** have the same characteristics as those described in association with trend graph **50a**.

[0037] The trend graph **50a-d** may be scaled and shaped as appropriate to fit within a user interface. The trend graph **50a-d** may be interchangeable. The larger trend graph **50a** can be replaced with one of smaller trend graphs **50b-c**. The larger trend graph **50a** can be minimized and exchanged with one of the smaller trend graphs **50b-d**. In some embodiment the trend graphs can change position based on the occurrence of an event. For example, in if an alarm is triggered in one of the trend graphs **50b-d**, trend graph **50a** could be replaced with the alarming parameter by the patient monitoring system.

[0038] The health indicators illustrated in the user interface **100** can have ranges and thresholds to help evaluate the health and wellness of the patient. A range can have one or more thresholds. Some physiological parameters may have upper thresholds and lower thresholds, while other parameters may only have an upper threshold or a lower threshold. The thresholds can be useful in tracking and monitoring a patient's health. Some physiological parameters can have a single threshold to determine whether the patient is in a healthy or unhealthy range. Some physiological parameters can have a plurality of thresholds that can be used to help evaluate the state of health of the patient. For example, a blood pressure measurement can identify different stages of hypertension, as illustrated in indicator **30b**. The ranges and thresholds can be adjusted based on the physiological parameter being monitored. For example, a SpO<sub>2</sub> health indicator, such as **10b**, can have only a lower threshold, whereas a heart rate indicator, such as **10a**, can have both an upper and a lower threshold.

[0039] The ranges and thresholds for each physiological parameter can be based on typical or expected values for a patient. The ranges and thresholds can be based on gender, age, height, weight, and other patient data. For example, females can have different ranges and thresholds than males. In some embodiments, a medical practitioner can determine ranges and thresholds for each parameter. In some embodiments, the patient monitoring system can determine the ranges and thresholds based at least in part on patient information provided to the system. A user can provide the system with information about the patient, such as gender, age, height, weight, medical history, and the like. The system can analyze the information and determine appropriate ranges and thresholds for the patient. In some embodiments, the ranges and thresholds can be determined by referencing one or more predefined look-up tables. In some embodiments, the ranges and thresholds can be calculated using one or more

algorithms. In some embodiments the user can modify the ranges and thresholds after the system has completed a determination of the ranges and thresholds.

[0040] When a threshold is met or exceeded, the system may be programmed to trigger an event. The event may be an alarm, an on-screen notification, an audible alarm, an electronic message sent to a health practitioner, or other user-specified event. In some embodiments, the user interface can change to indicate that an event has been triggered. For example, the indicators can change color, the indicator can flash, the indicator can increase in size, the indicator can switch to a different position on the display, or other change to the user interface to indicate that an event has been triggered. In some embodiments the triggered indicator can replace another more prominent indicator on the display

[0041] The health indicators can display the range and threshold information in a number of ways. The indicators can have marks, text, or other indication on the health indicator that identifies threshold. Other descriptors or annotations can be placed on the health indicators to identify ranges and or thresholds, which could be based on gender, age, or other information about the patient. The indicators can have numeric values associated with the descriptors. In some embodiments, no numeric values are associated with the indicators, such as the indicator **450** in FIG. 4. The indicators can have descriptors that indicate maximum and minimum thresholds for the physiological parameter, such as descriptors **422**, described in association with FIG. 4, showing minimum and maximums for males and females, or thresholds **58** in trend graph **50a**. A practitioner can use the ranges and thresholds to assess the severity of the physiological parameter levels.

[0042] In some embodiments, the ranges can be identified by color patterns, and the thresholds are identified by changes to the color pattern. This can aid the less educated or foreign language speakers to identify problems quickly. The color of the health indicator bars can indicate patient condition, such as normal, deteriorating, severe, and critical. For example, green can indicate a normal physiological signal, yellow can indicate a deteriorating condition, orange can indicate a severe condition, and red can indicate a critical condition. A health practitioner can quickly assess a patient's health by evaluating the color of each health indicator. This can be particularly helpful for when a health practitioner sees a new or unfamiliar patient. The patient monitoring system can use ranges and thresholds in all of the indicators.

[0043] FIG. 2 illustrates another configuration of the health indicators illustrated in FIG. 1.

[0044] FIG. 3 is another embodiment of a configuration of a user interface **300** that shows a plurality of health indicators for heart rate **10a**, respiration rate **10b**, temperature **30a**, blood pressure **30b**, glucose **150**, ECG **50c**, and respiration rate (RRa) **50d**, oxygen saturation (% SpO<sub>2</sub>) **80a**, perfusion index (PI) **80b**, total hemoglobin (SpHb) **80c**, carboxyhemoglobin (SpCO) **80d**, and bar indicators **90**. The heart rate **10a**, respiration rate **10b**, temperature **30a**, blood pressure **30b**, indicators are substantially the same as the indicators described in association with FIG. 1. In this embodiment of the user interface **300**, the indicators have been positioned and sized differently than those in FIG. 1.

[0045] The user interface **300** illustrates another embodiment of a trend chart **150**. The trend chart **150** is substantially similar to the trend chart **50a**. The trend chart **150** has upper and lower thresholds forming three regions, identified by

descriptors on the left side of the chart. Measurement values above the upper threshold are “High,” measurement values below the lower threshold are “Low,” and measurement values between the upper and lower thresholds are “Safe.” In this embodiment the current measurement value is displayed by the lines on the trend graph and not by a numerical indicator.

[0046] The user interface 300 illustrates another embodiment of a vertical bar indicator 90. The measurement value is illustrated by the height of the indicator 90. The width of the indicators 90 can indicate the amount of data being used and the upper and lower bounds next to the indicators 90 can indicate specific measurement values. In some embodiments, the indicator can change color to indicate the criticality of the measurement value. For example the indicator can be red if the value exceeds a threshold.

[0047] The user interface 300 also includes digital indicators for oxygen saturation (% SpO<sub>2</sub>) 80a, perfusion index (PI) 80b, total hemoglobin (SpHb) 80c, and carboxyhemoglobin (SpCO) 80d. The indicators 80a-d display the current values of the various physiological parameters. The indicator 80a is larger than the other indicators 80b-d. The indicators can be configured to position the indicator that is most critical in the position of indicator 80a. The measured value can be colored to indicate the level of patient wellness. In some embodiments the indicators can illuminate or flash based on the occurrence of an event, such as an alarm.

[0048] FIG. 4 illustrates another embodiment of a user interface 400. The user interface 400 shows a plurality of health indicators, including total hemoglobin (SpHb), circular indicator 410a and Gaussian indicator 450, oxygen saturation (SpO<sub>2</sub>) 410b, heart rate (PR) 410c, and perfusion index (PI) 410d. The user interface 400 also includes network information 430, power, battery power 432, time 434, patient site information 436, and additional program specific commands 440a-d.

[0049] The user interface 400 illustrates another embodiment of circular indicators 410a-d. The circular indicators 410a-d have a gauge 412 arranged circumferentially about a numeric value 416. In this embodiment, a quarter of the indicator is used to display the name and units of the physiological parameter and  $\frac{3}{4}$  of the indicator is the gauge 412. The gauge 412 can illuminate to correspond to the current sensor measurement. The gauge can include one or more blocks, as illustrated in 410a-c. The circular indicator 410a can have a measurement pointer 420 that identifies the current measurement. In some embodiments the gauge 412 has a color pattern associated with the health indicator reading.

[0050] The circular indicators 410a-d can have one or more reference points 418 at specific positions about the indicator. The reference points 418 can be lines, points, or other indicators that can indicate ranges and thresholds of the physiological parameter. In some embodiments, no values are displayed on the gauge, such as 410d. In some embodiments, reference point 418 can have numeric values, such as indicators 410a-c.

[0051] The indicators can have descriptors or reference information 422 on or about the gauge 412. The descriptors 422 can indicate wellness thresholds or other information related to the health indicator. The health indicator 410a has descriptors 422 showing ranges for male and female patients. In some embodiments, the descriptors 422 can illustrate ranges for other classifications such as age (e.g., children, elderly, etc.), fitness level (e.g., athlete), or other classifica-

tion. In some embodiments the descriptors 422 can indicate a maximum threshold and/or a minimum threshold.

[0052] The circular indicators 410a-d may be interchangeable. The larger indicator 410a can be replaced with one of smaller indicators 410b-d. The larger indicator 410a can be reduced in size and the other indicator can be increased in size. In some embodiments the indicator 450 can also be replaced when the indicator 410a is replaced. In some embodiment the indicators 410a-d can change position based on the occurrence of an event. For example, if an alarm is triggered in one of the indicators 410b-d, indicator 410a could be replaced with the alarming parameter by the patient monitoring system.

[0053] In some embodiments the indicators 410a-d can illustrate trends based on the color and intensity of the gauge 412. In one embodiment the highest intensity portion of the gauge 412 can indicate the most recent measurement with the intensity reducing for previous measurements. The intensity can be varied by the luminescence and/or the shade of color of the gauge 412. The intensity can be varied based on time or the number of measurements. For example, an indicator may be configured to show the last four measurements, with each measurement having a different intensity. In another example, the indicator may show measurements over the previous hour with a representative measurement shown for every ten minute period having a different intensity. In some embodiments the intensity can be increased to show which value has the most measurements, similar to a Gaussian trend. In some embodiments the indicator can have discrete intensity levels and/or colors that indicate timing of the measurements. For example the indicator 410c has three blocks that can represent different intensities and/or colors. In some embodiments the gauge can use the color associated with the severity of the measurement, for example if the measurement is a healthy measurement, that portion of the gauge can be a shade of green, whereas if it is an unhealthy measurement, that portion of the gauge can be a shade of red.

[0054] The user interface 400 also includes the indicator 450 configured to illustrate a distribution of measurements over a period of time, such as a Gaussian trend. The Gaussian trend indicator can have descriptors 452, an indicator 454, a distribution graph 456. The indicator 454 can indicate the current measurement. The distribution graph 456 indicates the amount of time spent at each measurement relative to other measurements. The distribution graph can be updated with each measurement. In some embodiments, the distribution graph can calculate the distribution for an indefinite period of time. In some embodiments the distribution can be a rolling window of time that only monitors distribution for a set amount of time going backwards. For example, the distribution graph 456 could show the distribution of measurements for 30 minutes, one hour, 6 hours, 24 hours or any appropriate length of time. An example of a Gaussian trend graph 460 being used in conjunction with a circular indicator is illustrated in indicator 410d. An embodiment of a time distribution graph, such as a Gaussian trend, can be used in conjunction with all indicators and parameters discussed herein.

[0055] The user interface 400 also includes exemplary program specific commands 440a-d. In this embodiment, the program specific commands include paging a medical practitioner 440a, sending the user interface information via electronic messaging 440b, printing 440c, and exiting out of the interface 440d.

[0056] FIG. 5 illustrates an embodiment of a patient monitoring system 500. In the depicted embodiment, the patient monitoring system 500 includes a display 520 and a monitoring device 500, which includes a finger clip sensor 501 connected to a monitor 509 via a cable 512. The patient monitoring system display 520 is configured to display a user interface 522, such as one of the user interfaces described in association with FIGS. 1-4.

[0057] In the embodiment shown, the monitor 509 includes a display 510. The monitor 509 can advantageously include electronic processing, signal processing, and data storage devices capable of receiving signal data from said sensor 501, processing the signal data to determine one or more output measurement values indicative of one or more physiological parameters of a monitored patient, and displaying the measurement values, trends of the measurement values, combinations of measurement values, and the like.

[0058] The monitor 509 can also include other components, such as a speaker, power button, removable storage or memory (e.g., a flash card slot), an AC power port, one or more control buttons 508 and one or more network interfaces, such as a universal serial bus interface or an Ethernet port. The display 510 can have a user interface displaying one or more health indicators, such as the indicators described herein. The cable 512 connecting the sensor 501 and the monitor 509 can be implemented using one or more wires, optical fiber, flex circuits, or the like.

[0059] The embodiments set forth above are illustrative of inventive principles and features, and these principles may be applied to patient monitoring systems that have different user interfaces or health indicators that do not match the embodiments of the patient monitoring system illustrated in the Figures. For example, the user interfaces may have different or additional health indicators. The health indicators may have different sizes and shapes, or different color patterns. As such, the principles and features discussed herein can be applied in embodiments of various shapes, sizes and configurations.

[0060] Although this invention has been disclosed in the context of certain preferred embodiments and examples, it will be understood by those skilled in the art that the present invention extends beyond the specifically disclosed embodiments to other alternative embodiments and/or uses of the invention and obvious modifications and equivalents thereof. In addition, while a number of variations of the invention have been shown and described in detail, other modifications, which are within the scope of this invention, will be readily apparent to those of skill in the art based upon this disclosure. Accordingly, Applicants contemplate that various features and aspects of the disclosed embodiments can be combined with or substituted for one another in order to form varying modes of the disclosed invention. Thus, it is intended that the scope of the present invention herein disclosed should not be limited by the particular disclosed embodiments described above, but should be determined only by a fair reading of the claims that follow.

What is claimed is:

1. A patient monitoring system, comprising:

at least one physiological sensor including a first and second light emitter and a detector, wherein the physiological sensor is configured to measure at least one physiological signal from a patient;

at least one health indicator, wherein the health indicator is configured to display a signal value based upon the at least one physiological signal;

a processor:

receive patient information;

calculate a first range of values for the at least one health indicator based at least in part on the patient information, wherein the first range of values corresponds to a first range of physiological signals from the patient, wherein the first range of values corresponds to a first patient condition;

calculate a second range of values for the at least one health indicator based at least in part on the patient information, wherein the second range of values corresponds to a second range of physiological signals from the patient, wherein the second range of values corresponds to a second patient condition; and

wherein the at least one health indicator is configured to display a first output when the signal value is within the first range of values; and

wherein the at least one health indicator is configured to display a second output when the signal value is within the second range of values.

2. The patient monitoring system of claim 1, wherein the first patient condition is a healthy condition.

3. The patient monitoring system of claim 1, wherein the first patient condition is an unhealthy condition.

4. The patient monitoring system of claim 1, wherein the patient monitoring system is further configured to calculate a third range of values for the health indicator, wherein the third range of values corresponds to a third range of physiological signals from the patient, wherein the third range of values corresponds to an intermediate patient condition;

5. The patient monitoring system of claim 4, wherein the first range of values, the second range of values, and the third range of values do not overlap.

6. The patient monitoring system of claim 1, wherein the first health indicator is configured to output an alarm signal when the signal value moves from the first range of values to the second range of values.

7. The patient monitoring system of claim 6, wherein the alarm signal is an audible alarm

8. The patient monitoring system of claim 1, wherein the first output is a first color displayed on the health indicator and the second output is a second color displayed on the health indicator.

9. The patient monitoring system of claim 1, wherein the first output and the second output are both displayed when the signal value is in the second range of values.

10. The patient monitoring system of claim 1, wherein the patient monitoring system is configured to communicate the signal value with a mobile device.

11. The patient monitoring system of claim 1, wherein the patient information is at least one of age, gender, height, or weight.

12. The patient monitoring system of claim 1, wherein the patient information is information associated with the medical history of the patient.

13. The patient monitoring system of claim 1, wherein the health indicator is a circular health indicator.

14. The patient monitoring system of claim 1, wherein the health indicator is a vertical bar indicator.

15. The patient monitoring system of claim 1, wherein the health indicator is a trend graph indicator.

16. The patient monitoring system of claim 15, wherein the health indicator is a wherein the signal value is a point on a trend graph.

17. The patient monitoring system of claim 1, wherein the signal value is a numeric value.

18. The patient monitoring system of claim 1, wherein the signal value is an analog indicator.

19. The patient monitoring system of claim 1, wherein the at least one physiological sensor is configured to measure glucose, blood pressure, pulse rate, respiration rate, oxygen saturation, total hemoglobin, carboxyhemoglobin, methemoglobin, perfusion index, or temperature.

20. The patient monitoring system of claim 1, wherein the physiological sensor is a pulse oximeter.

21. A method of monitoring a patient, comprising;  
receiving patient information;

calculating a first range of values for the health indicator, wherein the first range of values corresponds to a first range of physiological signals from the patient, wherein the first range of values corresponds to a healthy patient condition;

calculating a second range of values for the health indicator, wherein the second range of values corresponds to a second range of physiological signals from the patient;

wherein the second range of values corresponds to an unhealthy patient condition; and  
measuring at least one physiological signal from a patient using a physiological sensor having a first and second light emitter and a detector;

displaying the signal value on the first health indicator;  
displaying a first output on the health indicator when the first value is within the first range of values; and  
displaying a second output on the health indicator when the second value is within the second range of values.

22. The method of claim 21, further comprising the step of displaying a threshold indicator separating the first range of values from the second range of values.

23. The method of claim 21, wherein the physiological sensor is configured to measure glucose, blood pressure, pulse rate, respiration rate, oxygen saturation, total hemoglobin, carboxyhemoglobin, methemoglobin, perfusion index, or temperature.

24. The patient monitoring system of claim 21, wherein the patient information is at least one of age, gender, height, or weight.

\* \* \* \* \*

专利名称(译)	可配置的患者监护系统		
公开(公告)号	<a href="#">US20130211214A1</a>	公开(公告)日	2013-08-15
申请号	US13/762751	申请日	2013-02-08
[标]申请(专利权)人(译)	CERCACOR LAB		
当前申请(专利权)人(译)	Masimo公司		
[标]发明人	OLSEN GREGORY A		
发明人	OLSEN, GREGORY A.		
IPC分类号	A61B5/00 A61B5/01 A61B5/145 A61B5/0205 A61B5/026 A61B5/1455		
CPC分类号	A61B5/742 A61B5/744 A61B5/14551 A61B5/743 A61B5/0261 A61B5/14552 A61B5/0008 A61B5/14532 A61B5/02055 A61B5/01 A61B5/7282 A61B5/746 A61B5/7405 A61B5/14546 A61B5/021 A61B5/02416 A61B5/0816 G06T11/206 G06T13/80 G06T2219/2016 G16H40/63 G16H50/20		
优先权	61/597140 2012-02-09 US		
其他公开文献	US9480435		
外部链接	<a href="#">Espacenet</a> <a href="#">USPTO</a>		

摘要(译)

患者监测系统可以在可配置的用户界面上显示一个或多个可配置的健康监测器。健康指示器被配置为显示来自患者的生理信号。患者监测系统可以计算健康指标的值的范围，其对应于患者的状态。健康指示器可以基于生理信号的值显示不同的输出。

