



US 20190029578A1

(19) **United States**

(12) **Patent Application Publication**

**Al-Ali et al.**

(10) **Pub. No.: US 2019/0029578 A1**

(43) **Pub. Date: Jan. 31, 2019**

(54) **REGIONAL OXIMETRY USER INTERFACE**

(71) Applicant: **MASIMO CORPORATION**, Irvine, CA (US)

(72) Inventors: **Ammar Al-Ali**, San Juan Capistrano, CA (US); **Keith Ward Indorf**, Riverside, CA (US); **Faisal Kashif**, Irvine, CA (US)

(21) Appl. No.: **16/025,532**

(22) Filed: **Jul. 2, 2018**

(52) **U.S. Cl.**

CPC ..... **A61B 5/14542** (2013.01); **H01R 13/5224** (2013.01); **A61B 5/14552** (2013.01); **A61B 5/14553** (2013.01); **A61B 5/1455** (2013.01); **A61B 5/6833** (2013.01); **A61B 5/7275** (2013.01); **A61B 5/742** (2013.01); **A61B 5/14551** (2013.01); **A61B 5/14557** (2013.01); **A61B 2562/22** (2013.01); **A61B 2562/222** (2013.01); **A61B 2562/225** (2013.01); **A61B 2562/227** (2013.01); **A61B 2562/228** (2013.01); **H01R 2201/12** (2013.01); **A61B 5/746** (2013.01)

**Related U.S. Application Data**

(63) Continuation of application No. 14/507,660, filed on Oct. 6, 2014, now Pat. No. 10,010,276.

(60) Provisional application No. 62/012,170, filed on Jun. 13, 2014, provisional application No. 61/887,878, filed on Oct. 7, 2013, provisional application No. 61/887,856, filed on Oct. 7, 2013, provisional application No. 61/887,883, filed on Oct. 7, 2013.

**Publication Classification**

(51) **Int. Cl.**

**A61B 5/145** (2006.01)  
**A61B 5/00** (2006.01)  
**A61B 5/1455** (2006.01)  
**H01R 13/52** (2006.01)

(57)

**ABSTRACT**

A regional oximetry system has a display and at least one processor causing a plurality of views to be displayed on the display, each configured to occupy at least a portion of the display. The views are adapted to present data responsive to at least one physiological signal. A first sensor port is configured to receive at least a first physiological signal representative of a regional tissue oxygenation level, and a second sensor port is configured to receive at least a second physiological signal representative of an arterial oxygen saturation level. One view presents a first trend graph of the first physiological signal and a second trend graph of the second physiological signal. An area between the first trend graph and the second trend graph can include a differential analysis of regional-to-central oxygen saturation.

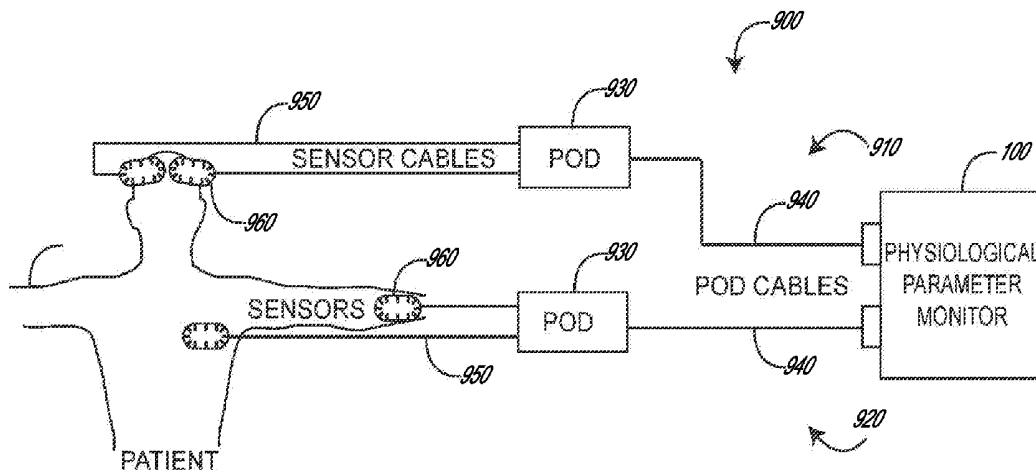

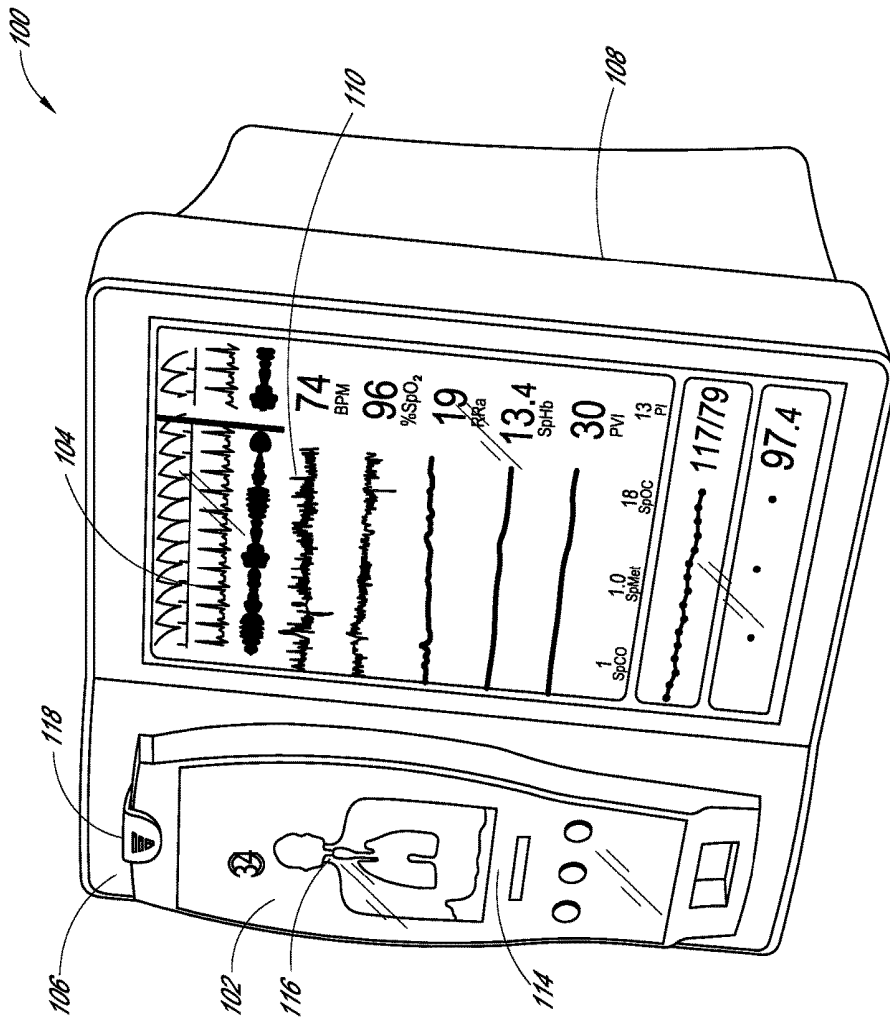

FIG. 1A

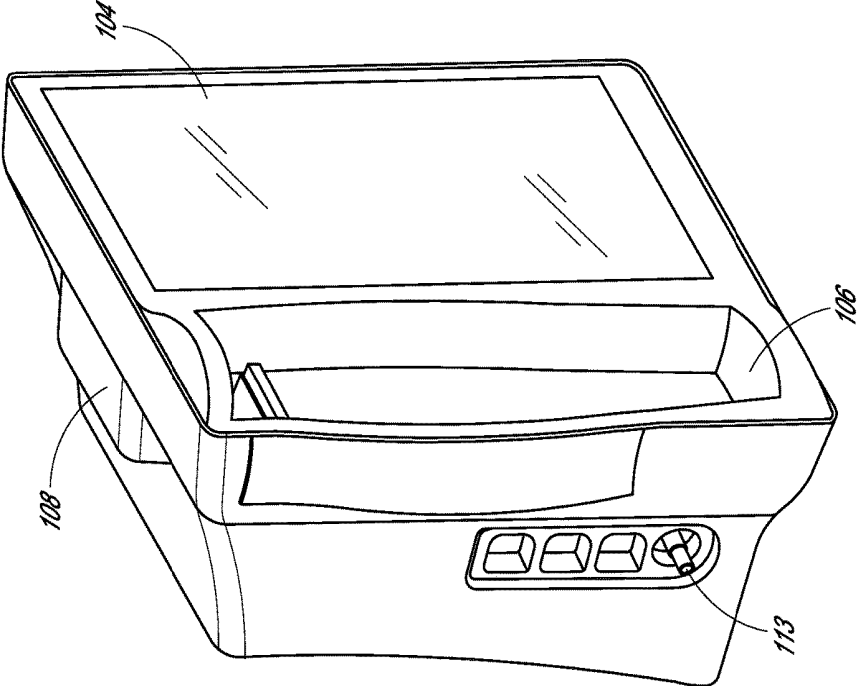

FIG. 1B

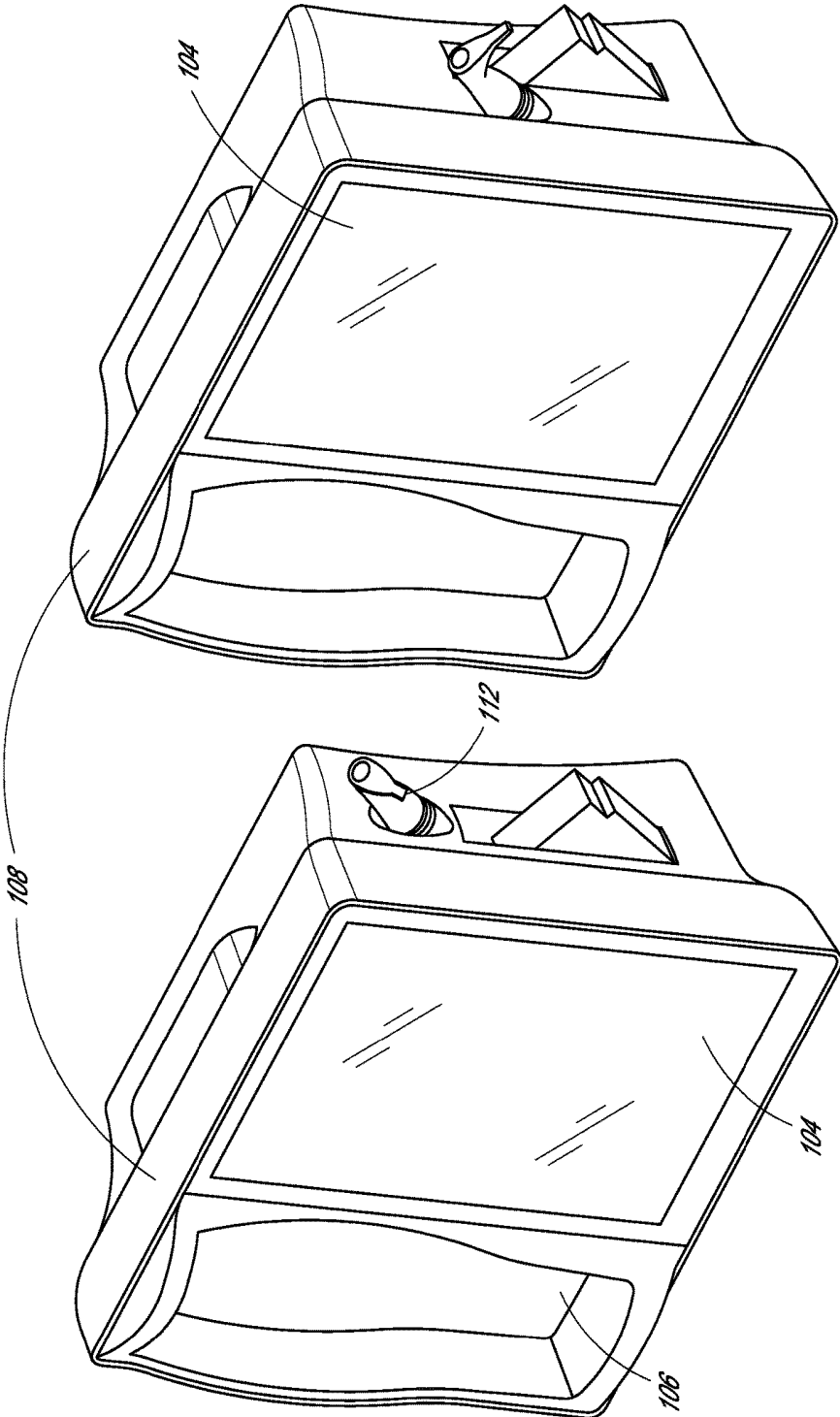

FIG. 1C

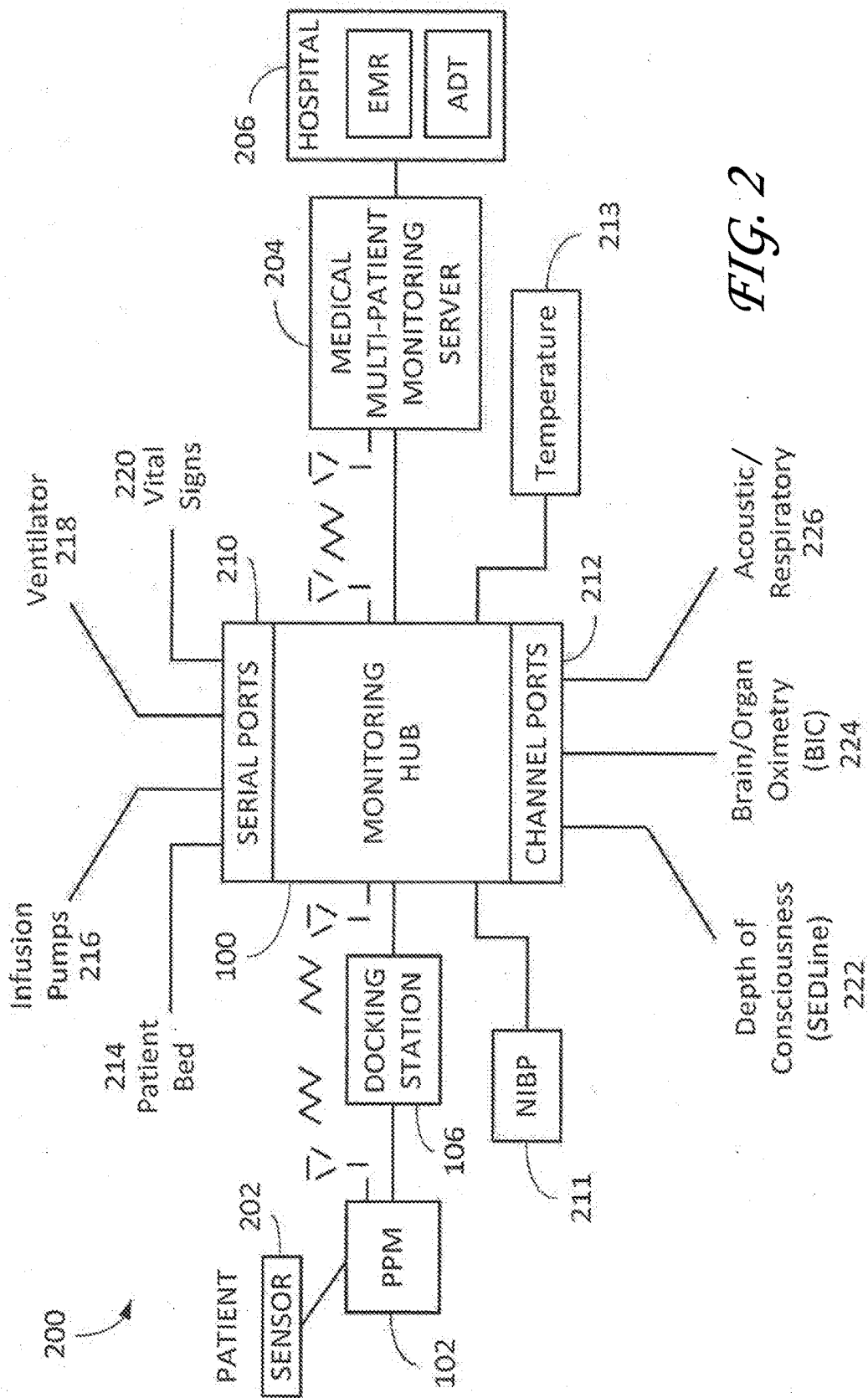

FIG. 2

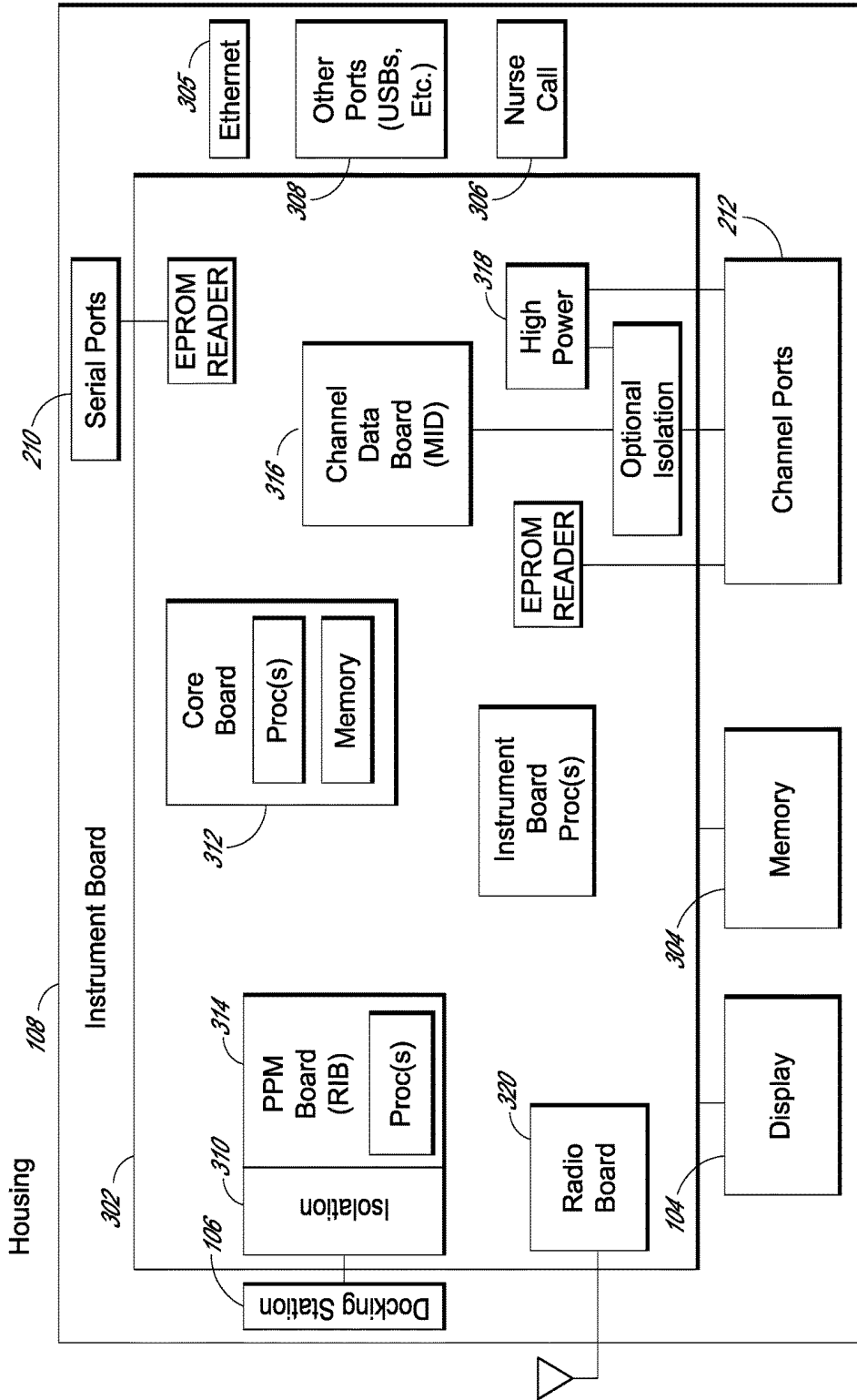
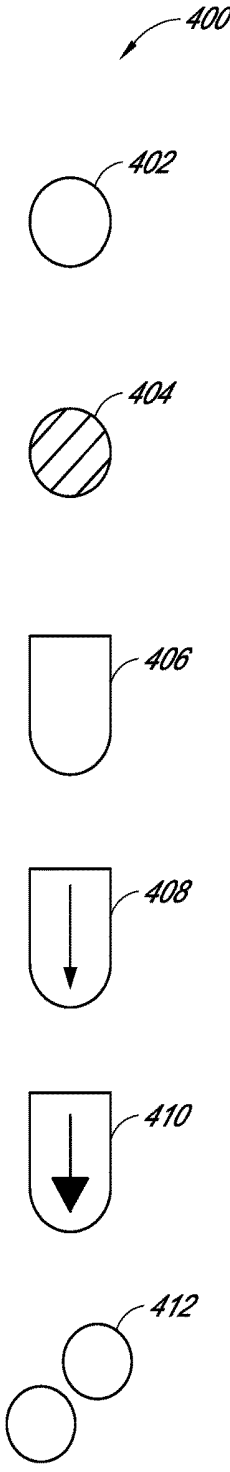

FIG. 3



*FIG. 4*

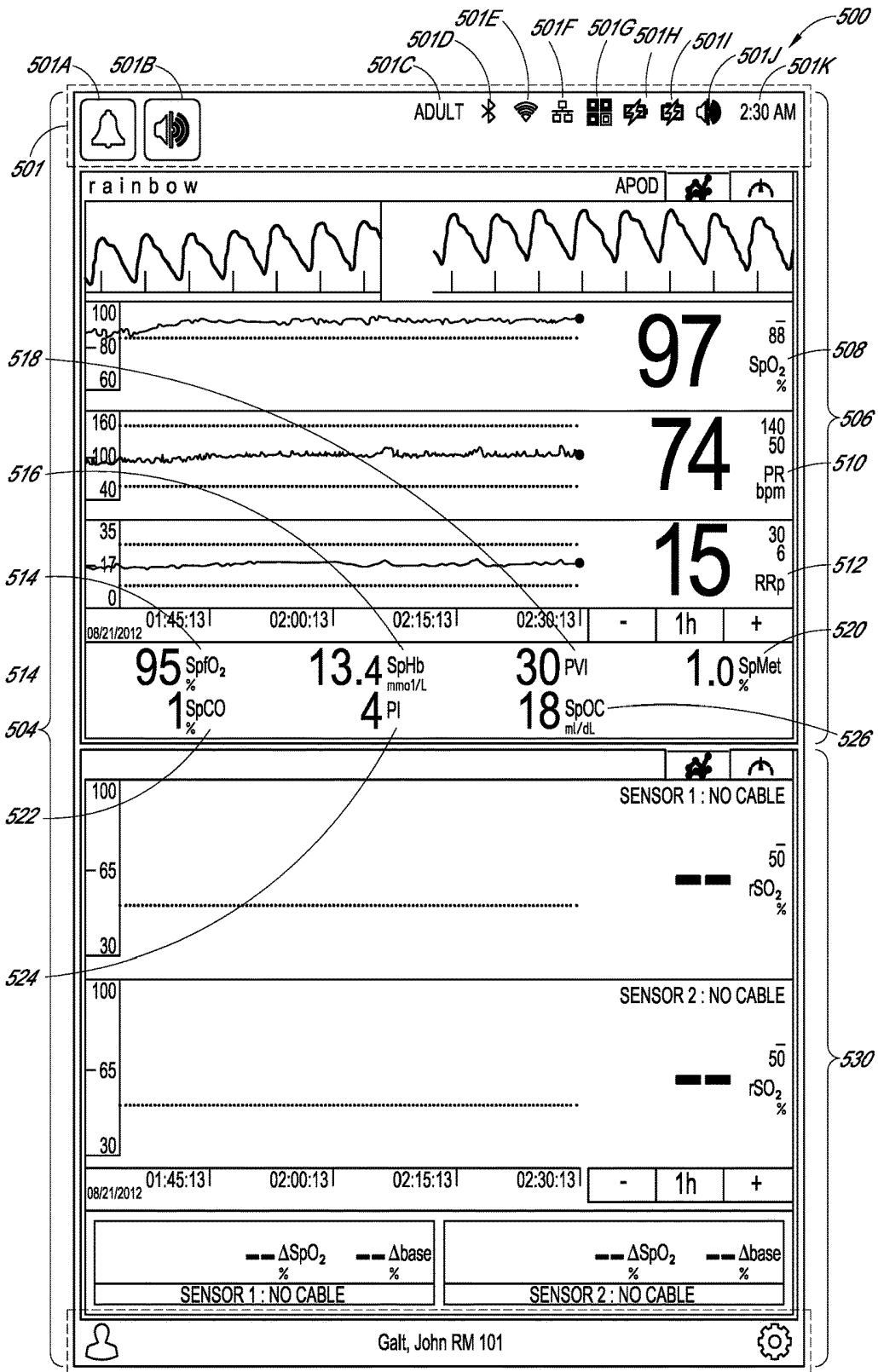
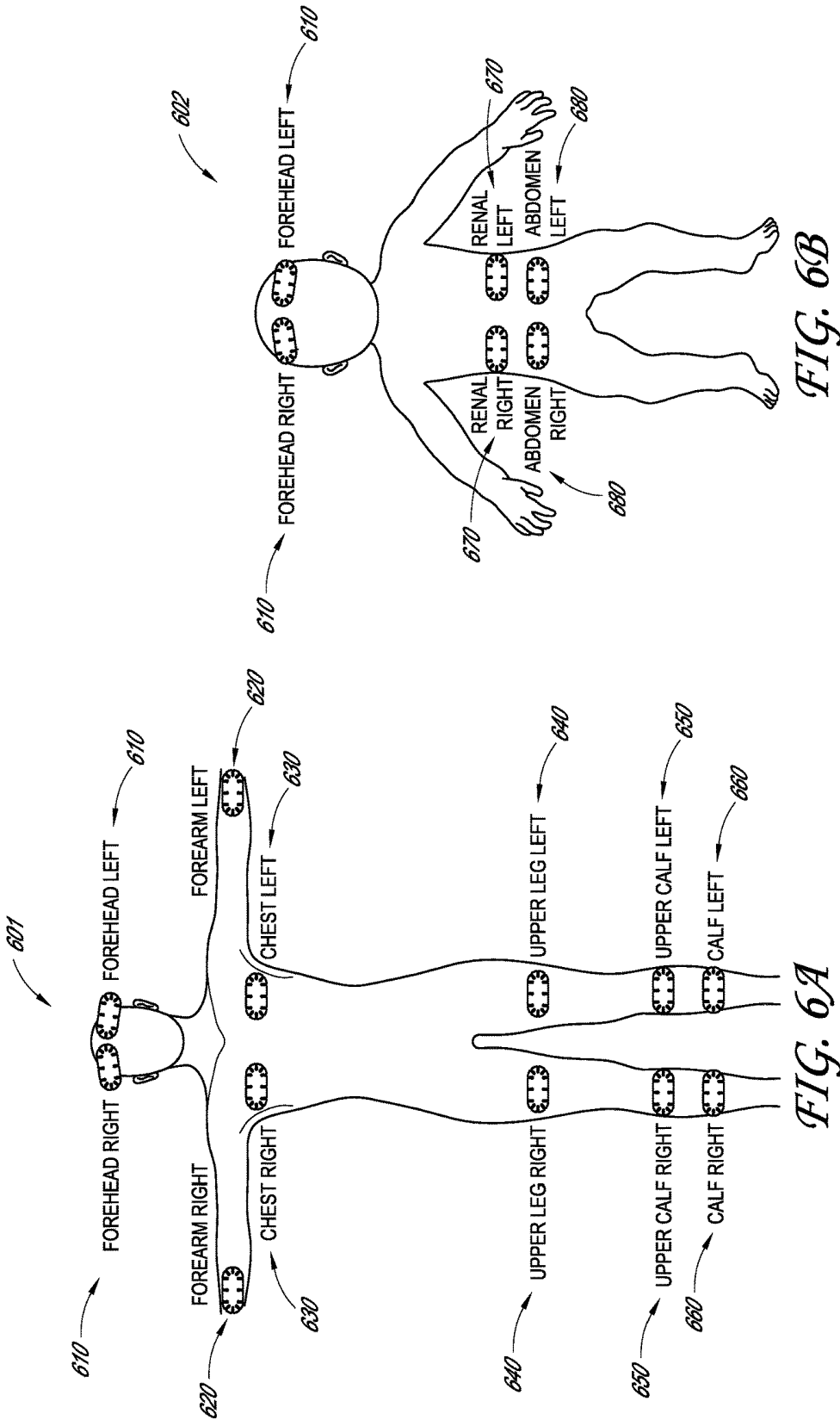

FIG. 5



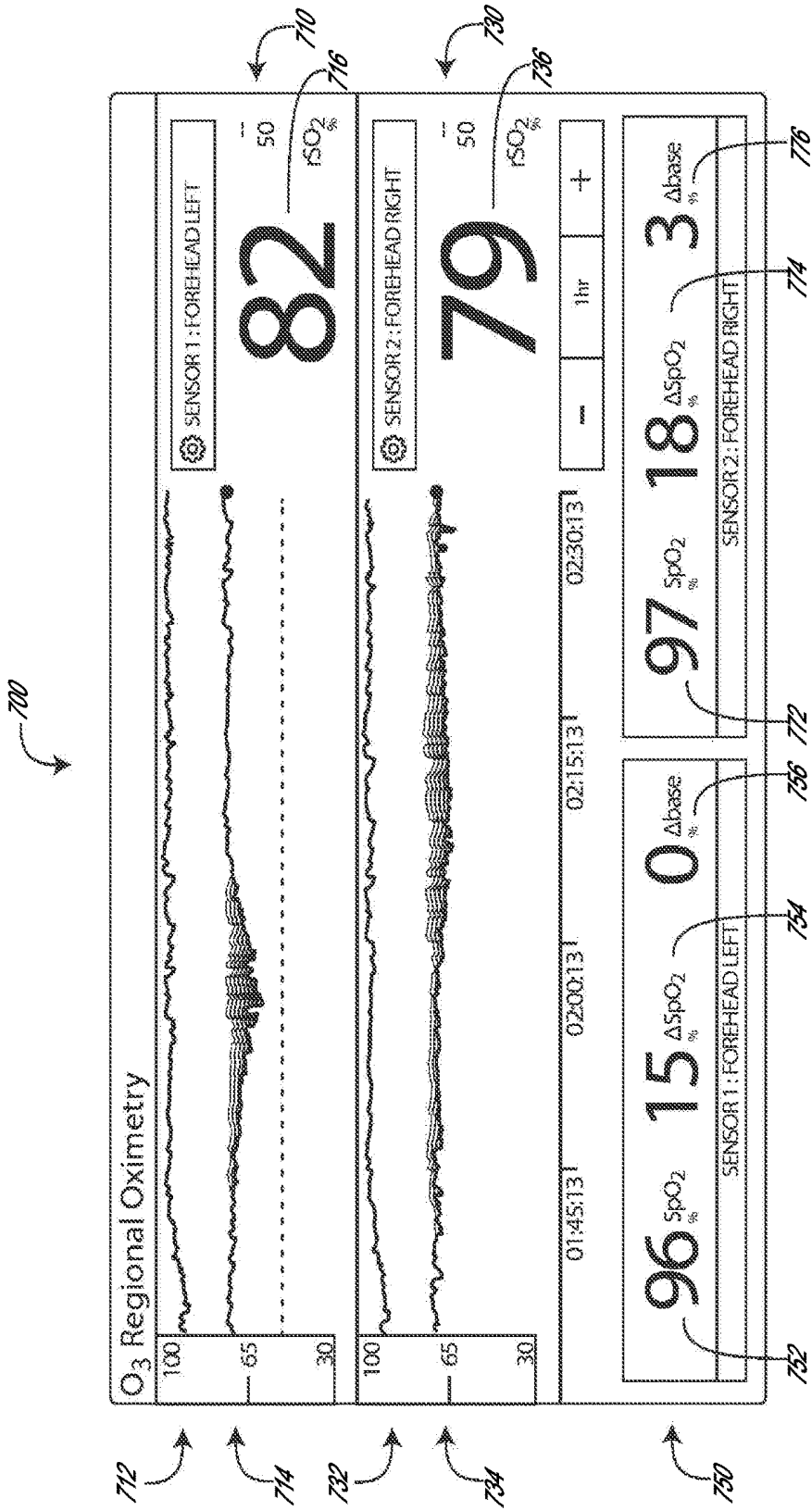

FIG. 7

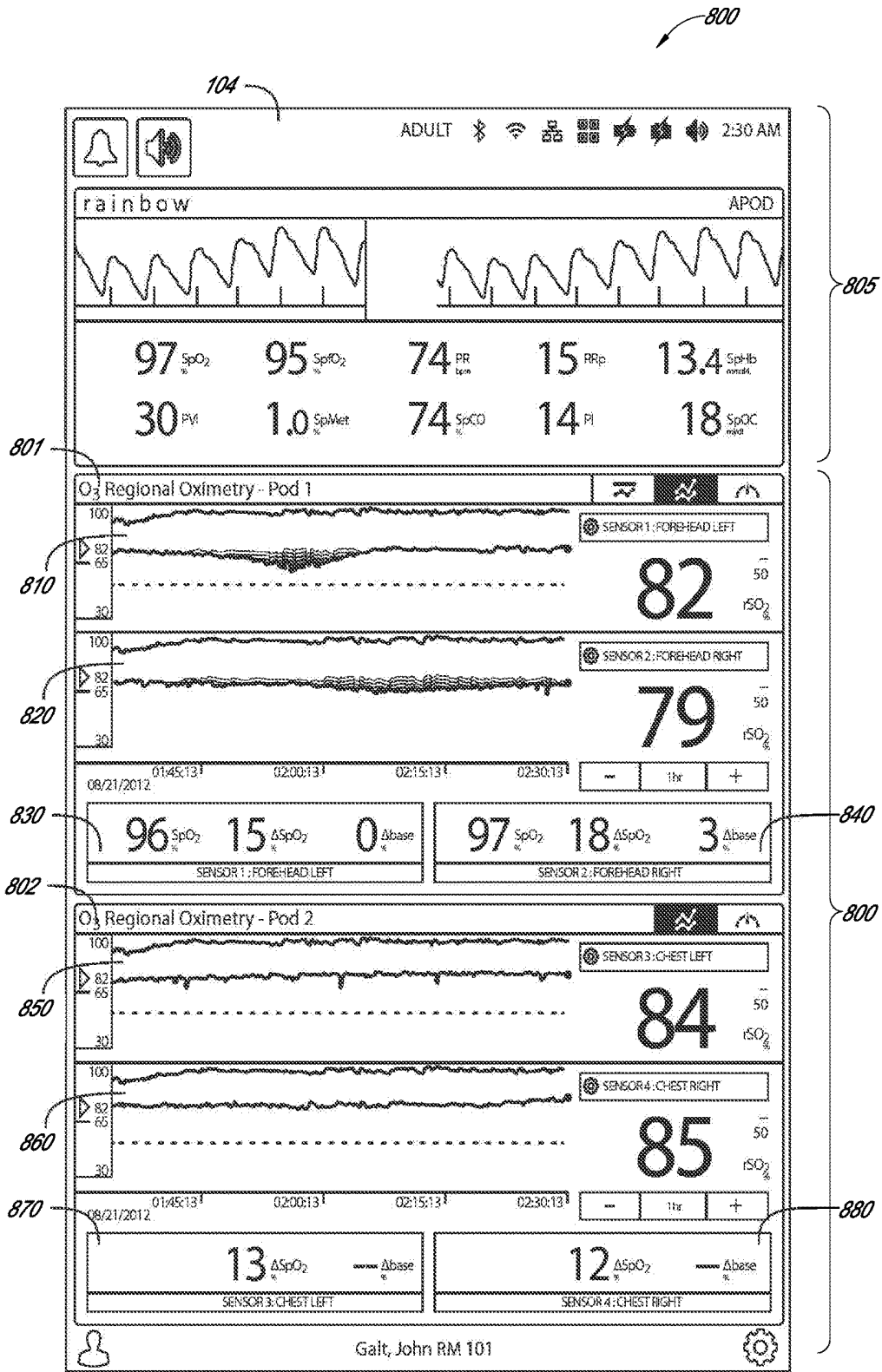

FIG. 8

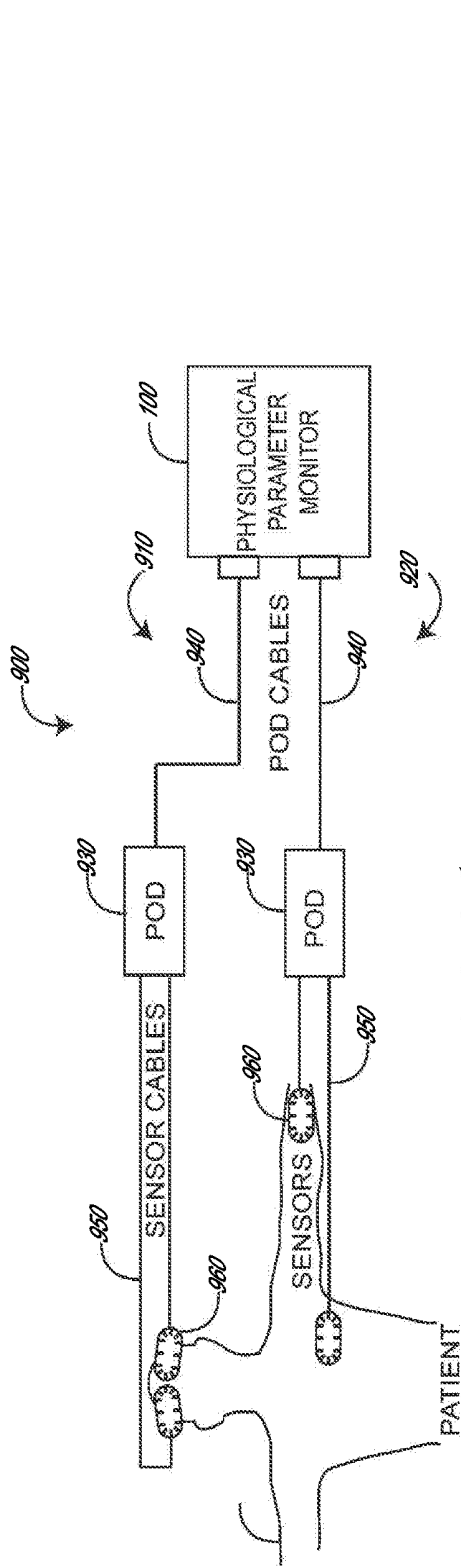

FIG. 9A

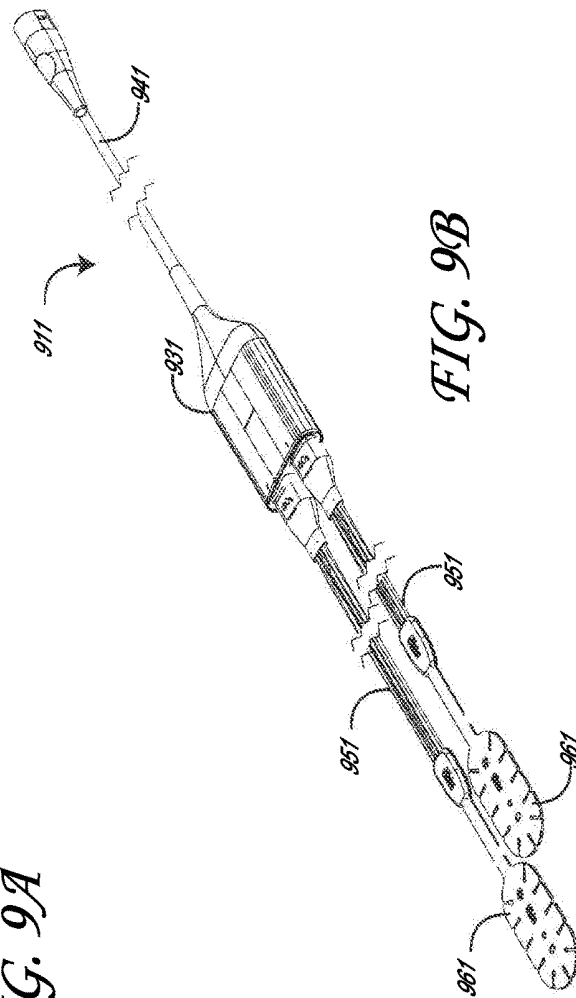

FIG. 9B

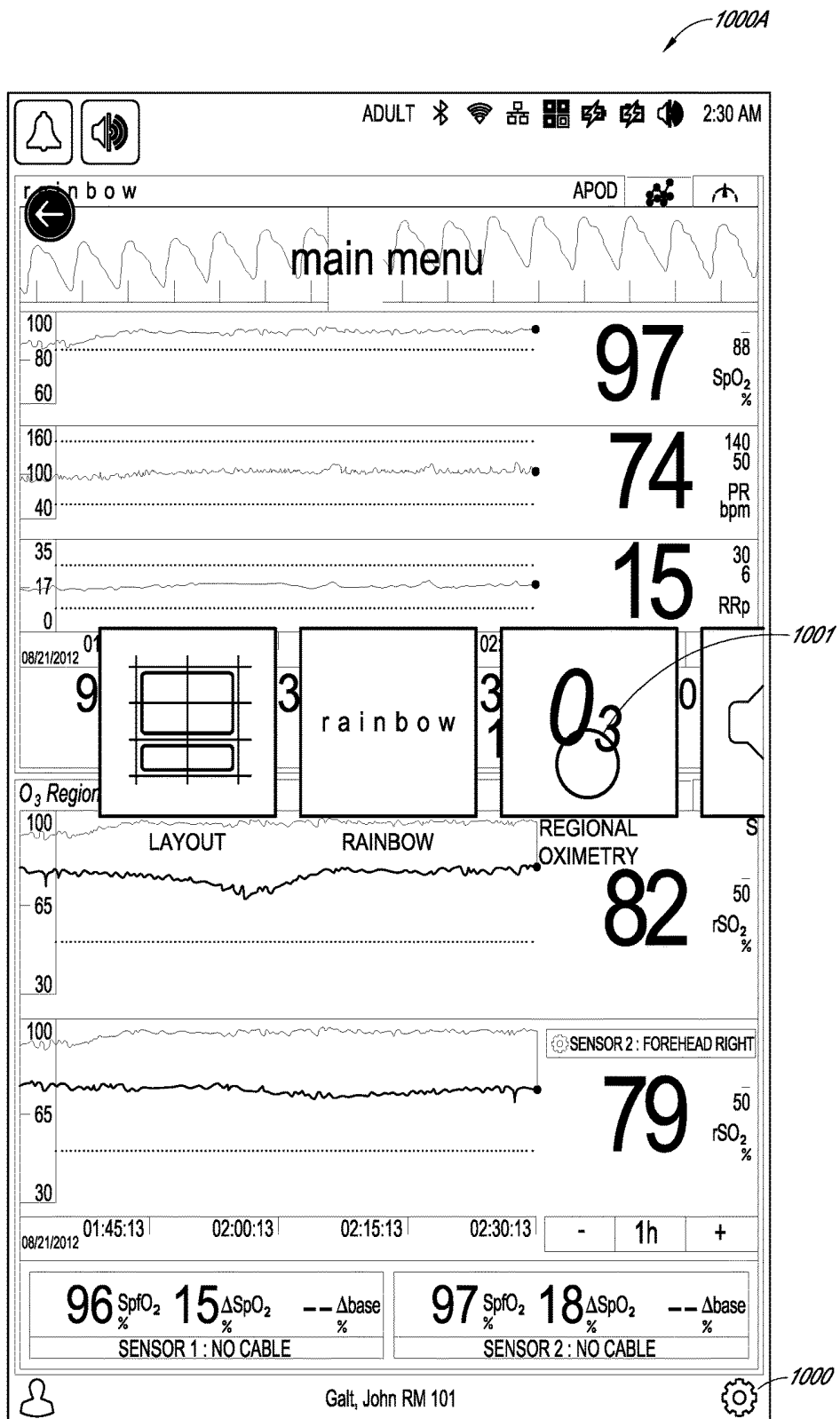

FIG. 10A

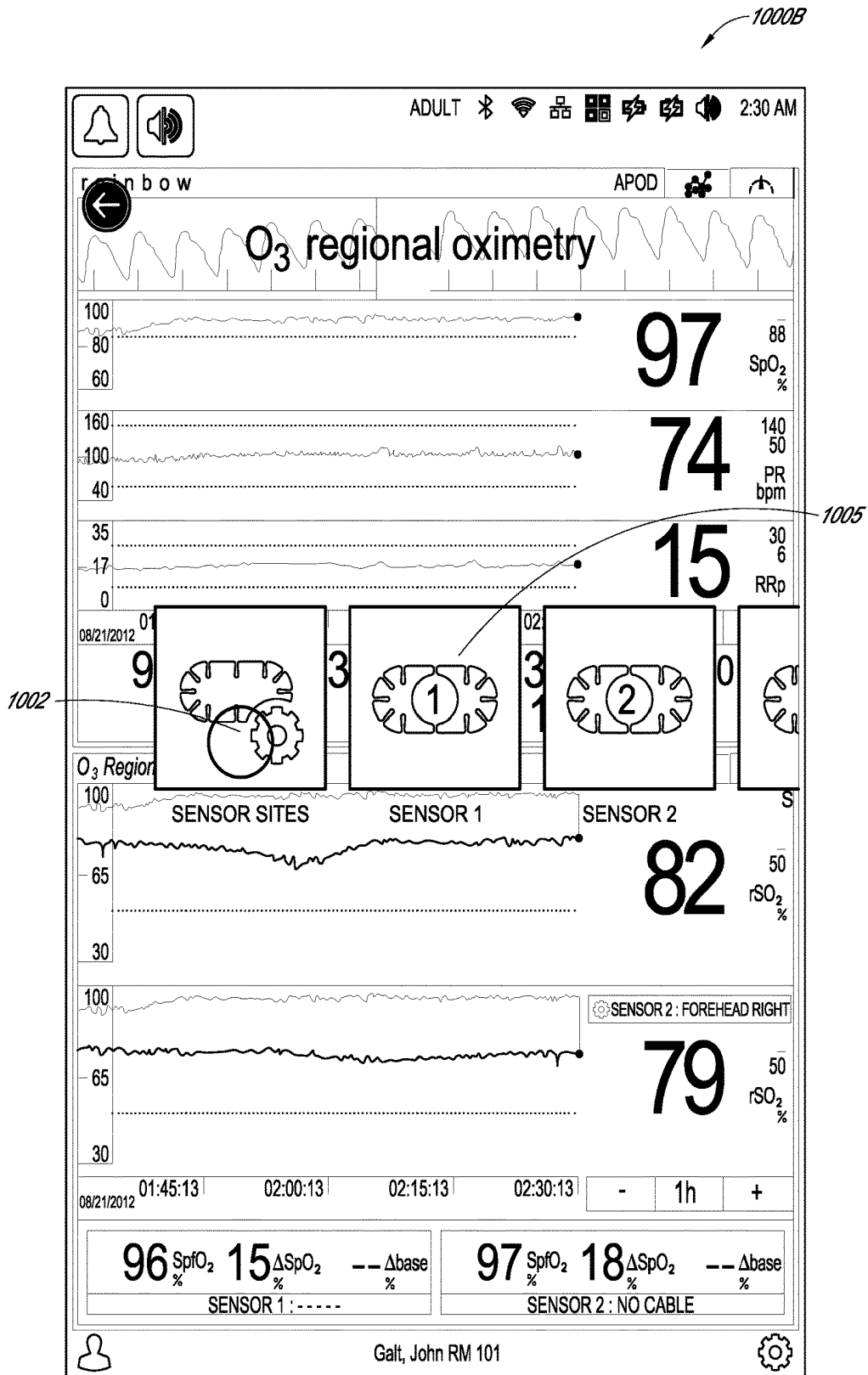

FIG. 10B

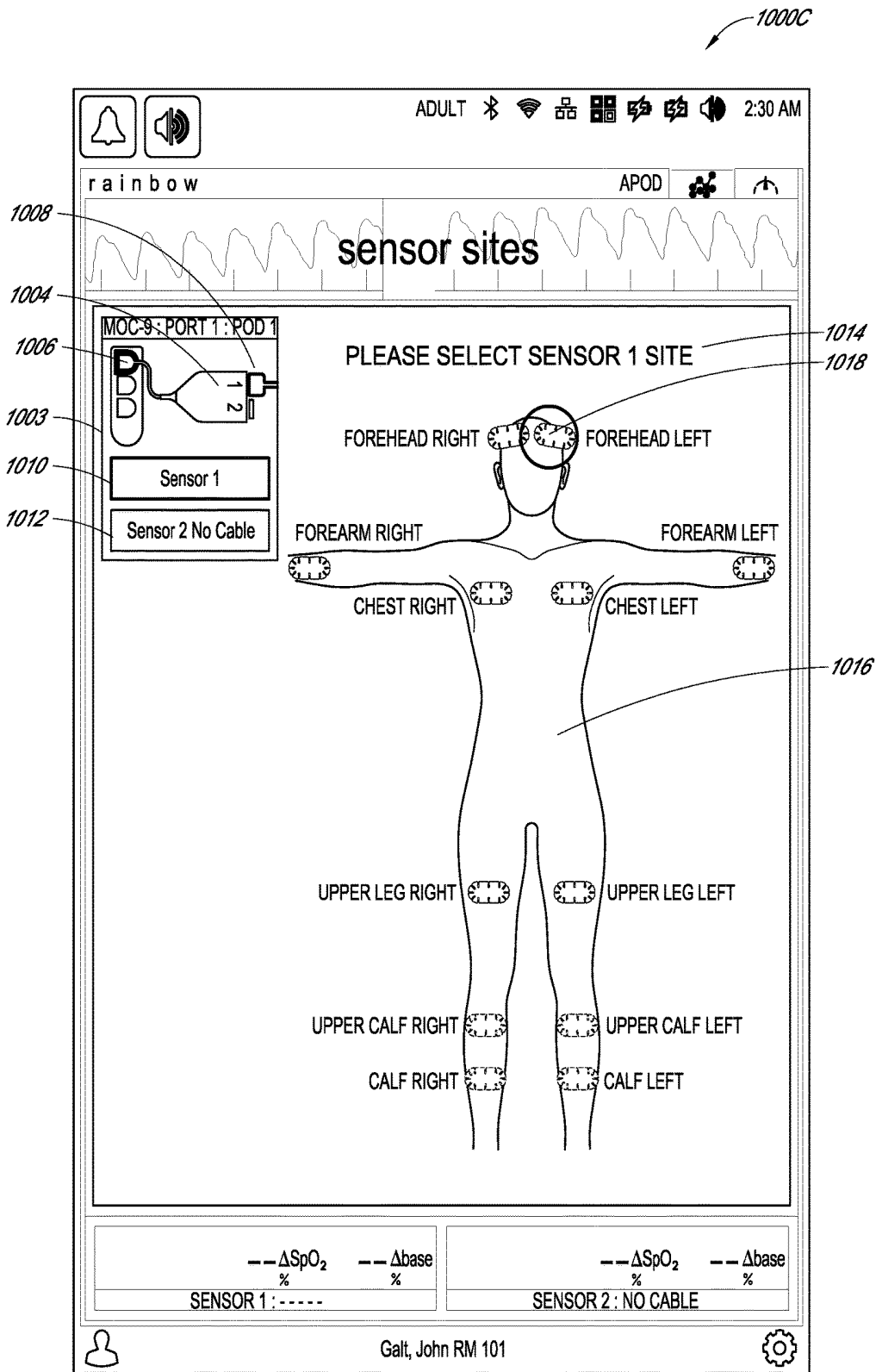

FIG. 10C

1000D

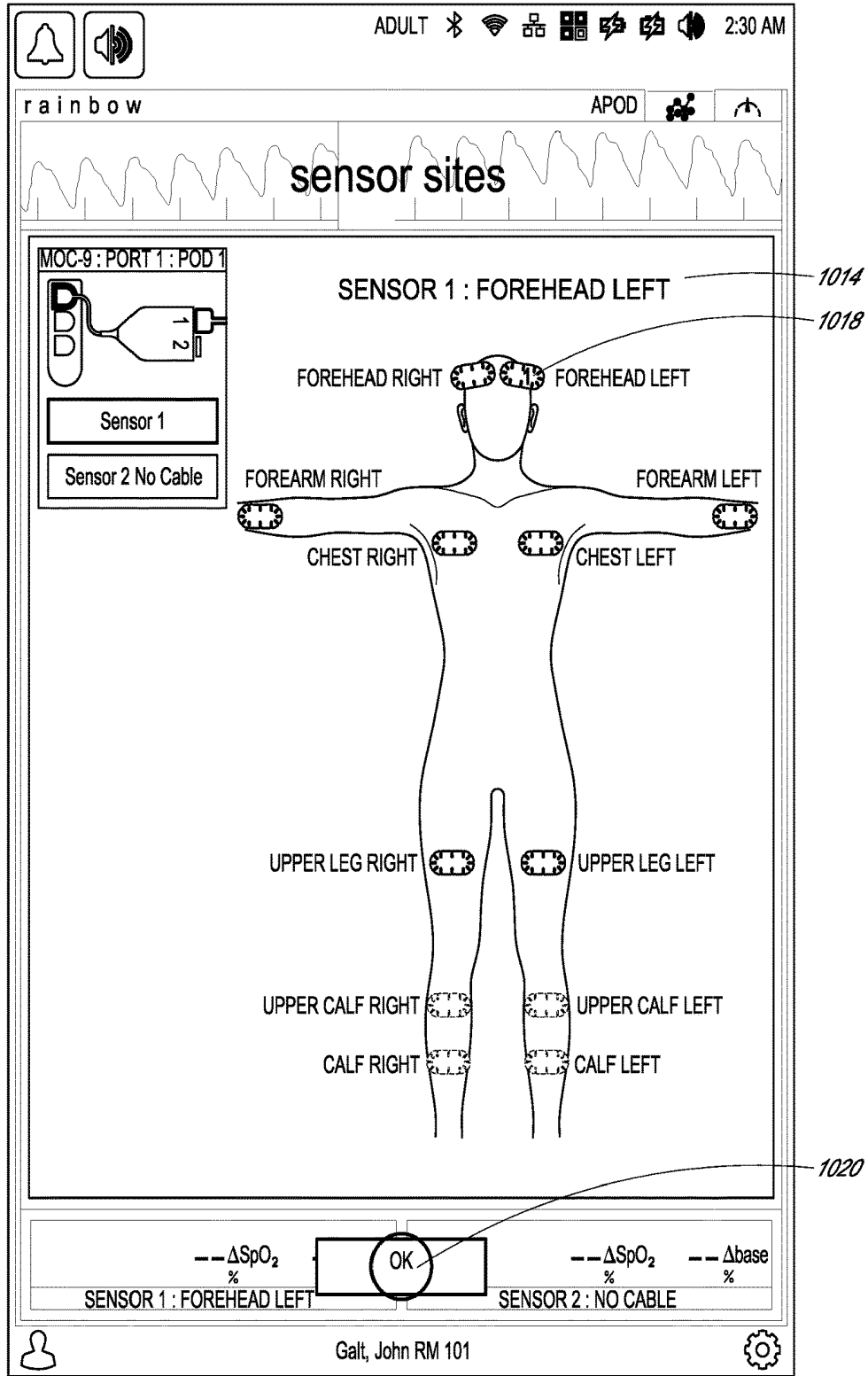

FIG. 10D

1000E

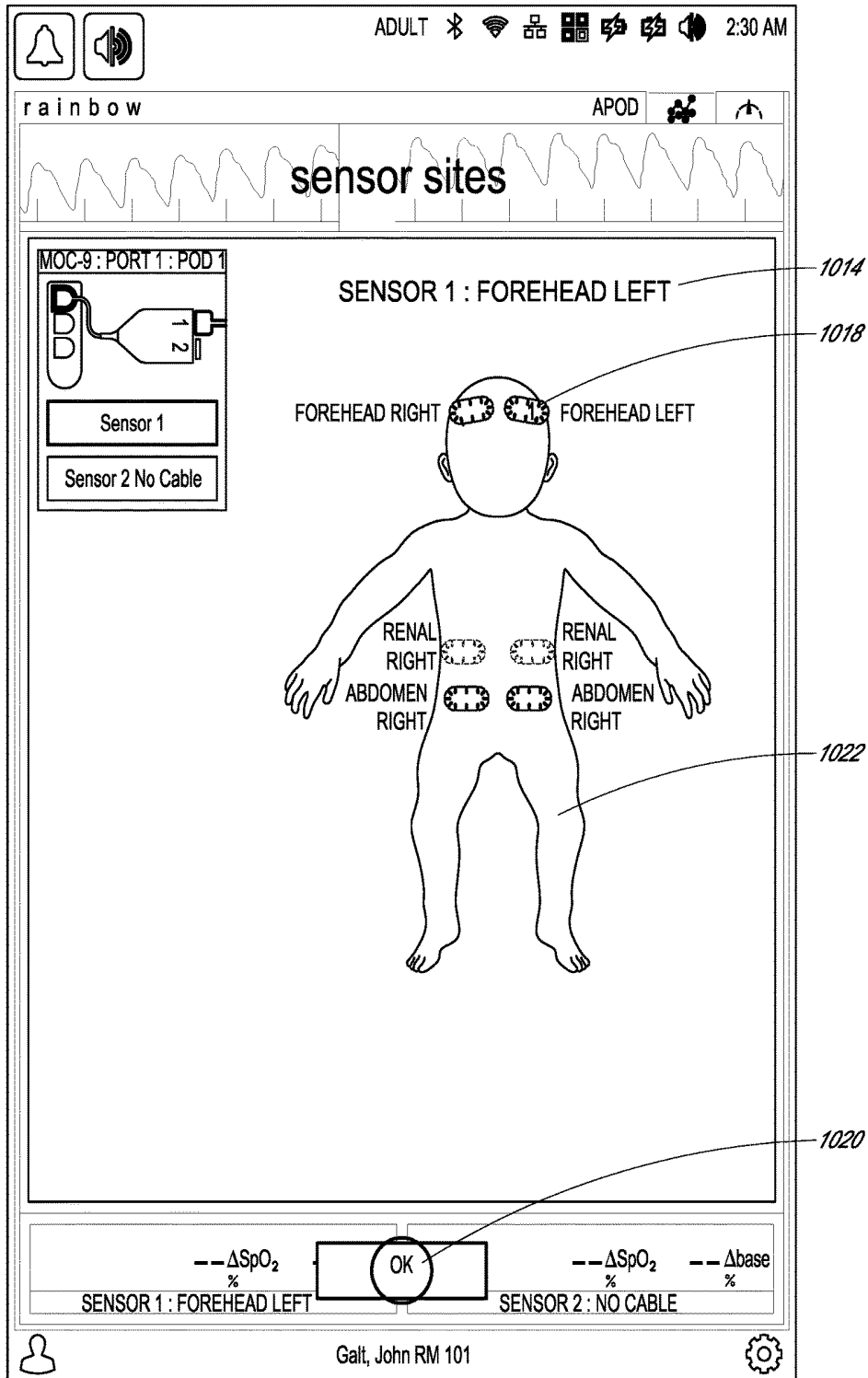

FIG. 10E

1000F

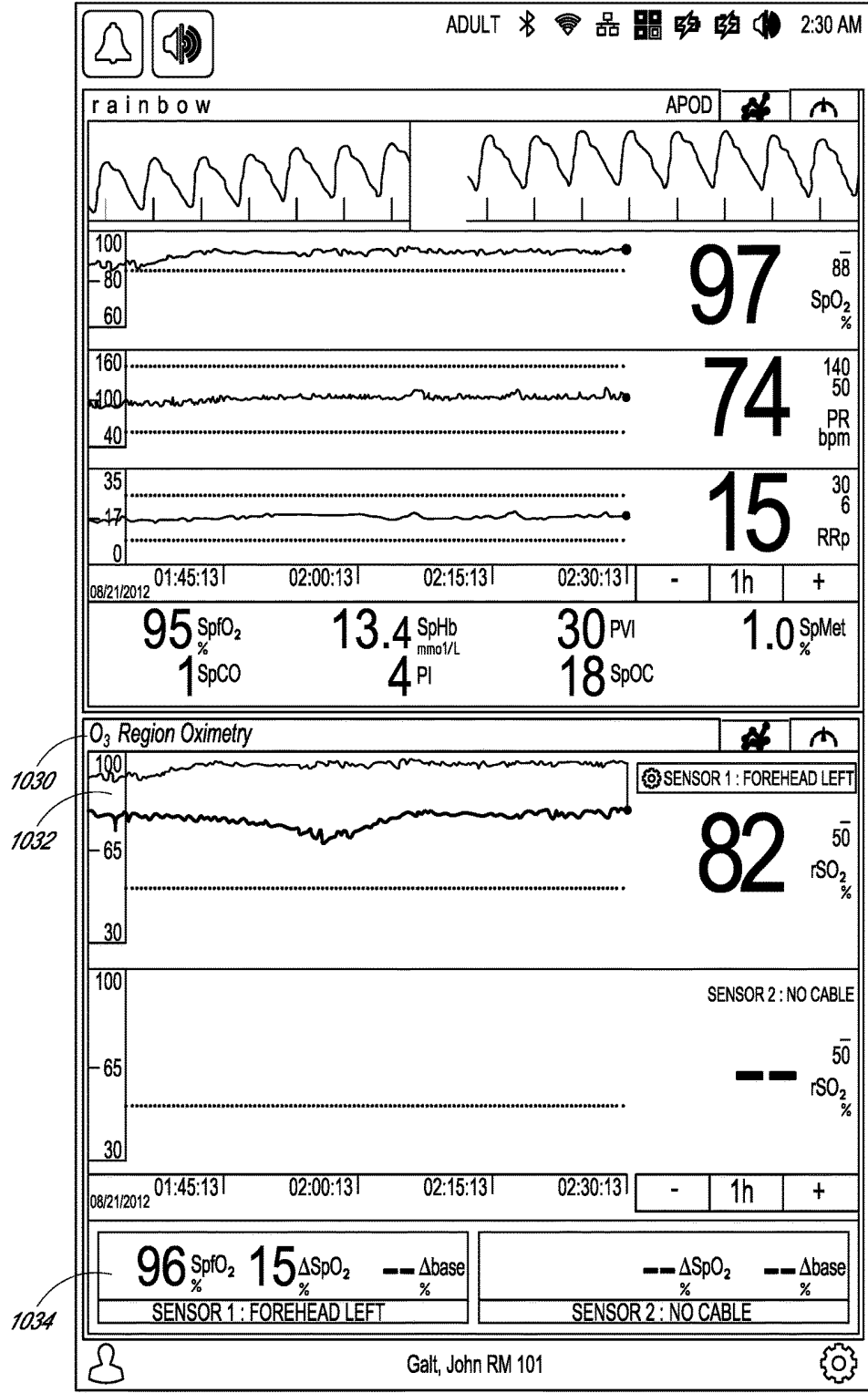
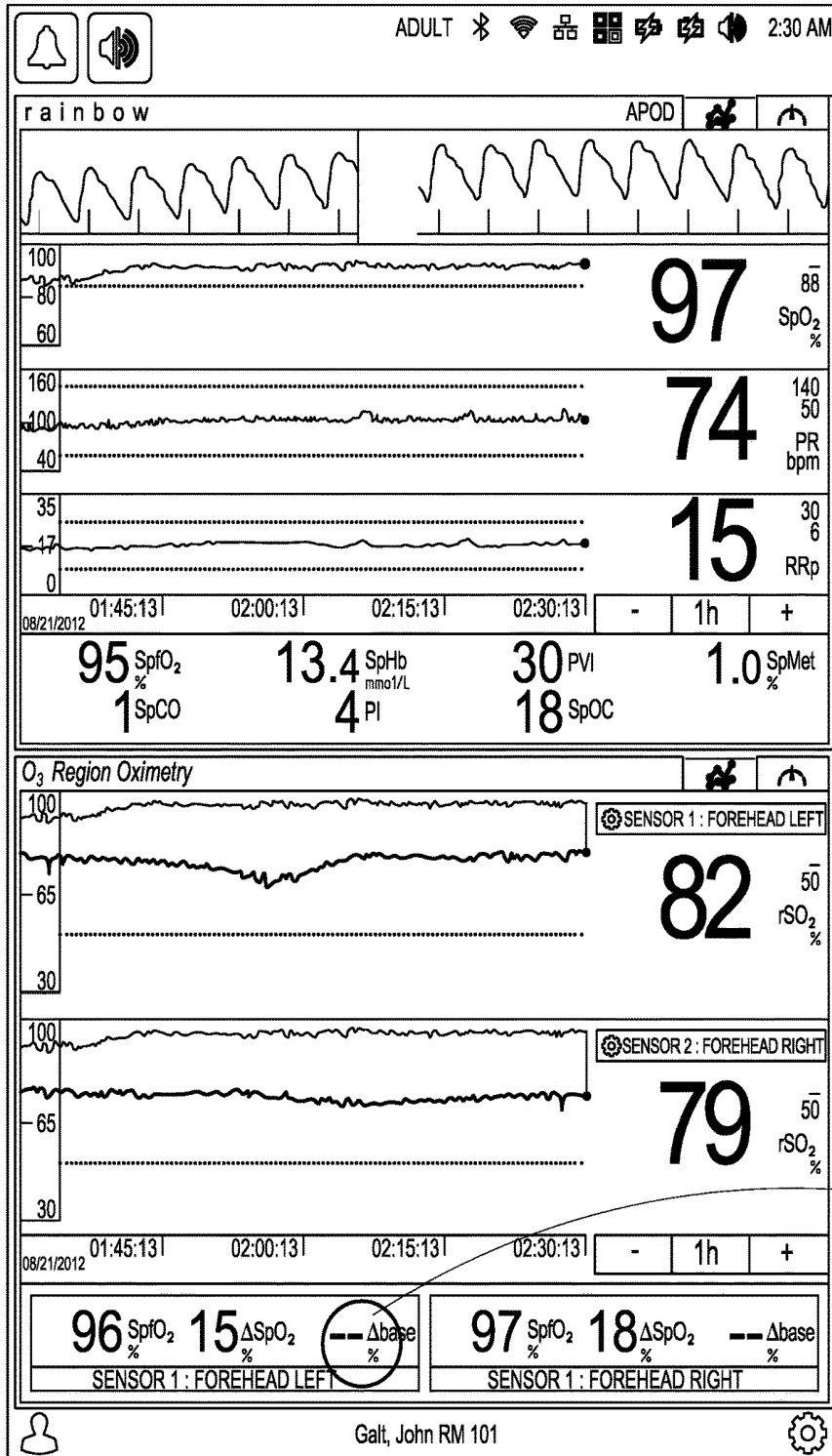

FIG. 10F

1100A



1102

FIG. 11A

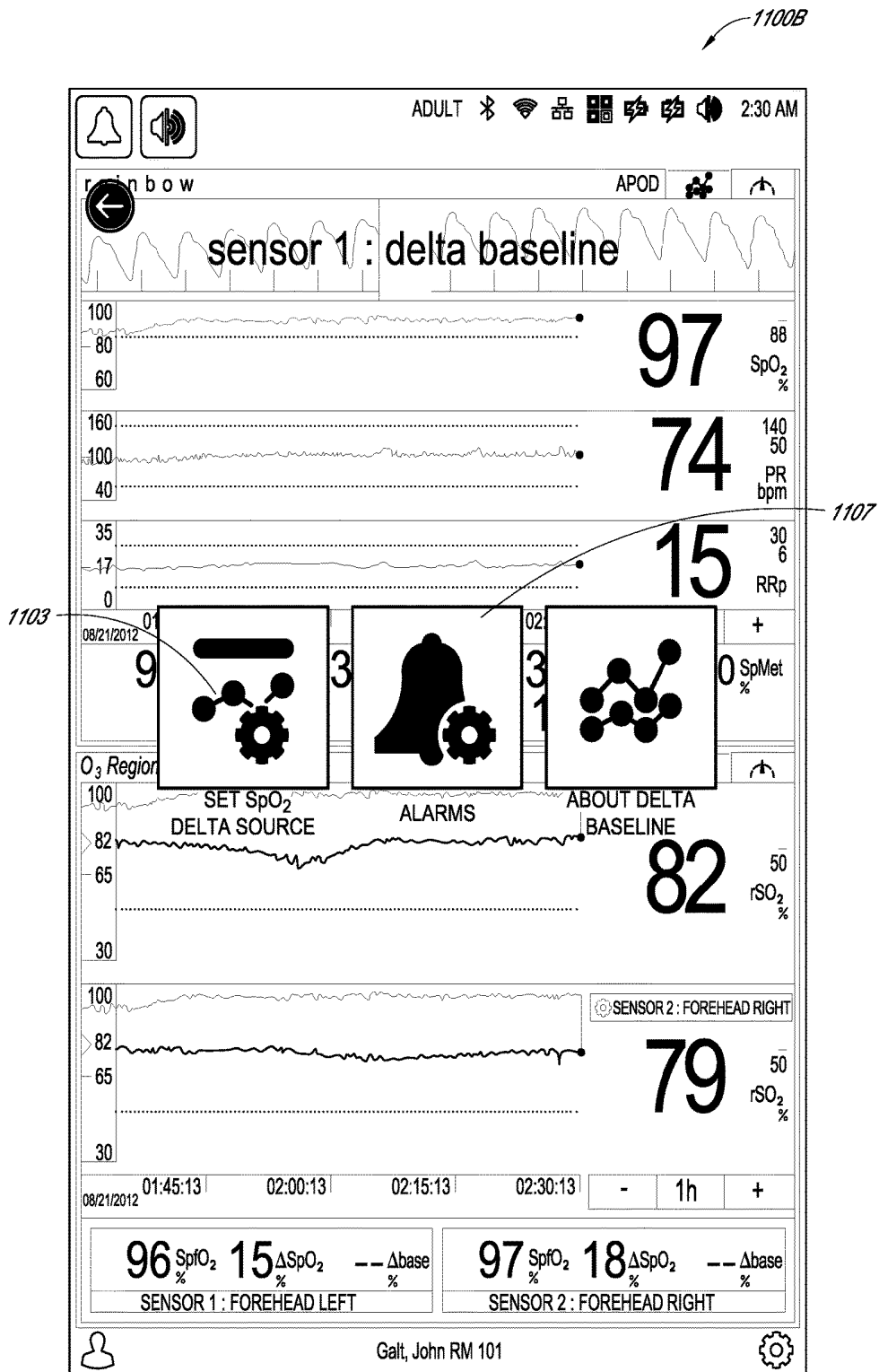

FIG. 11B

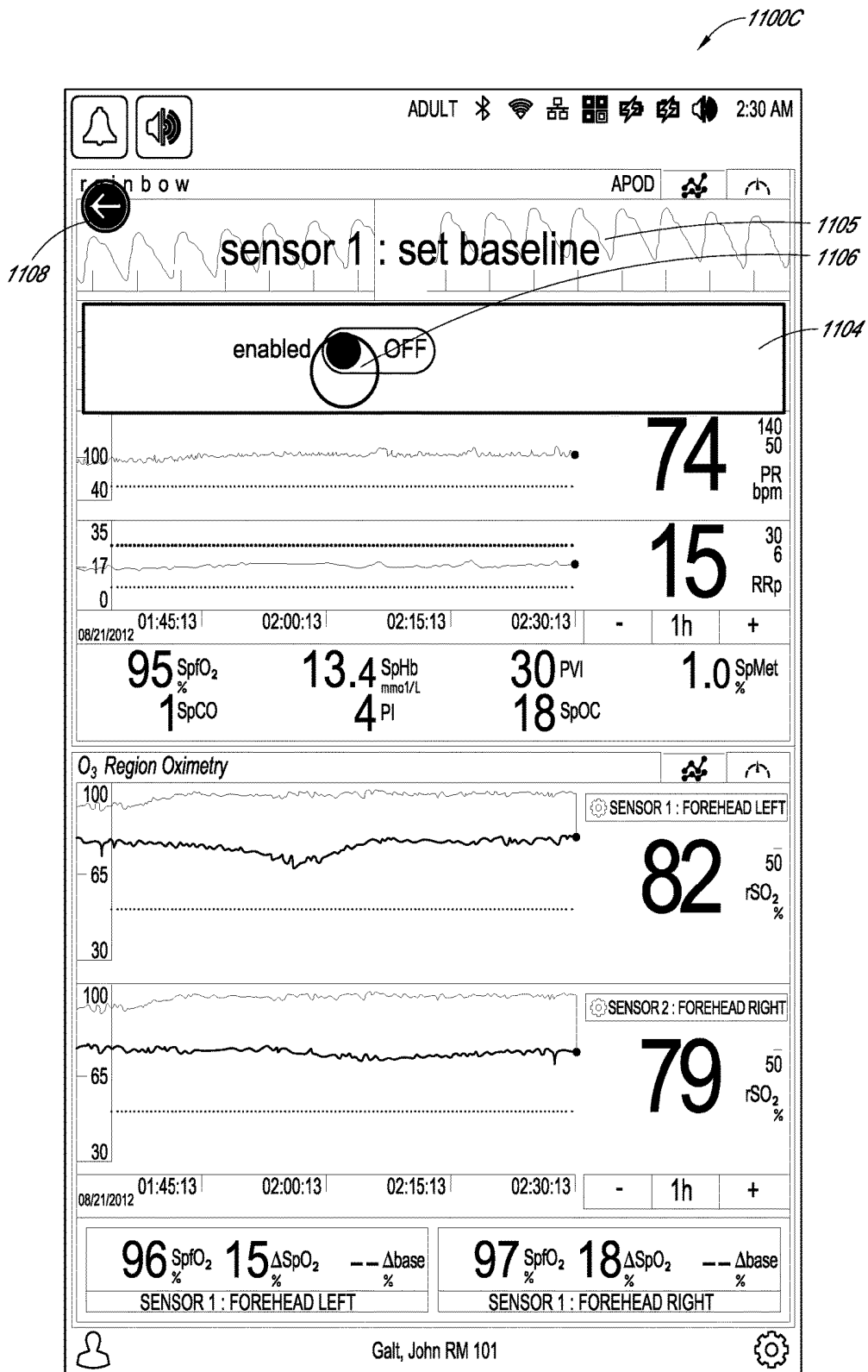

FIG. 11C

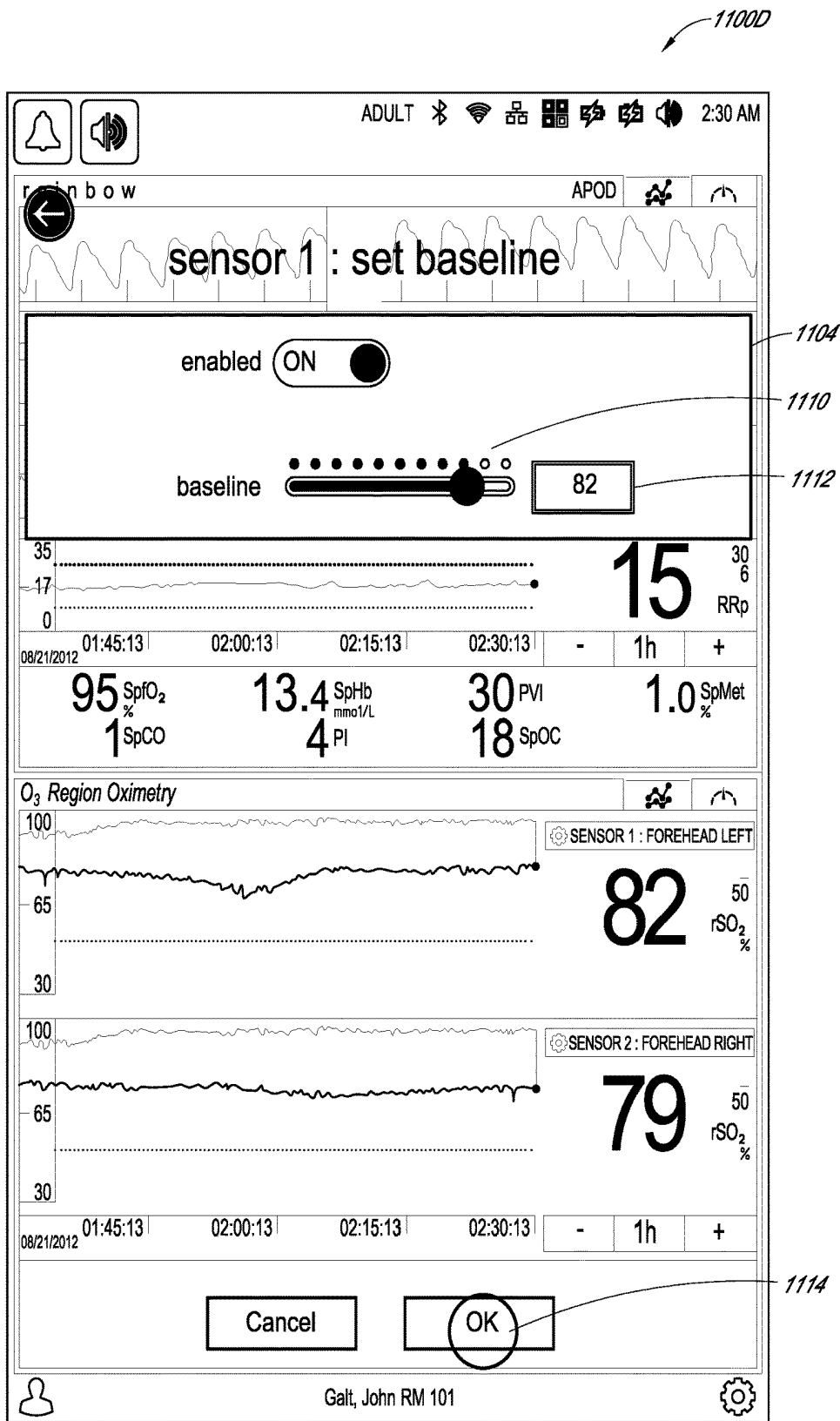

FIG. 11D

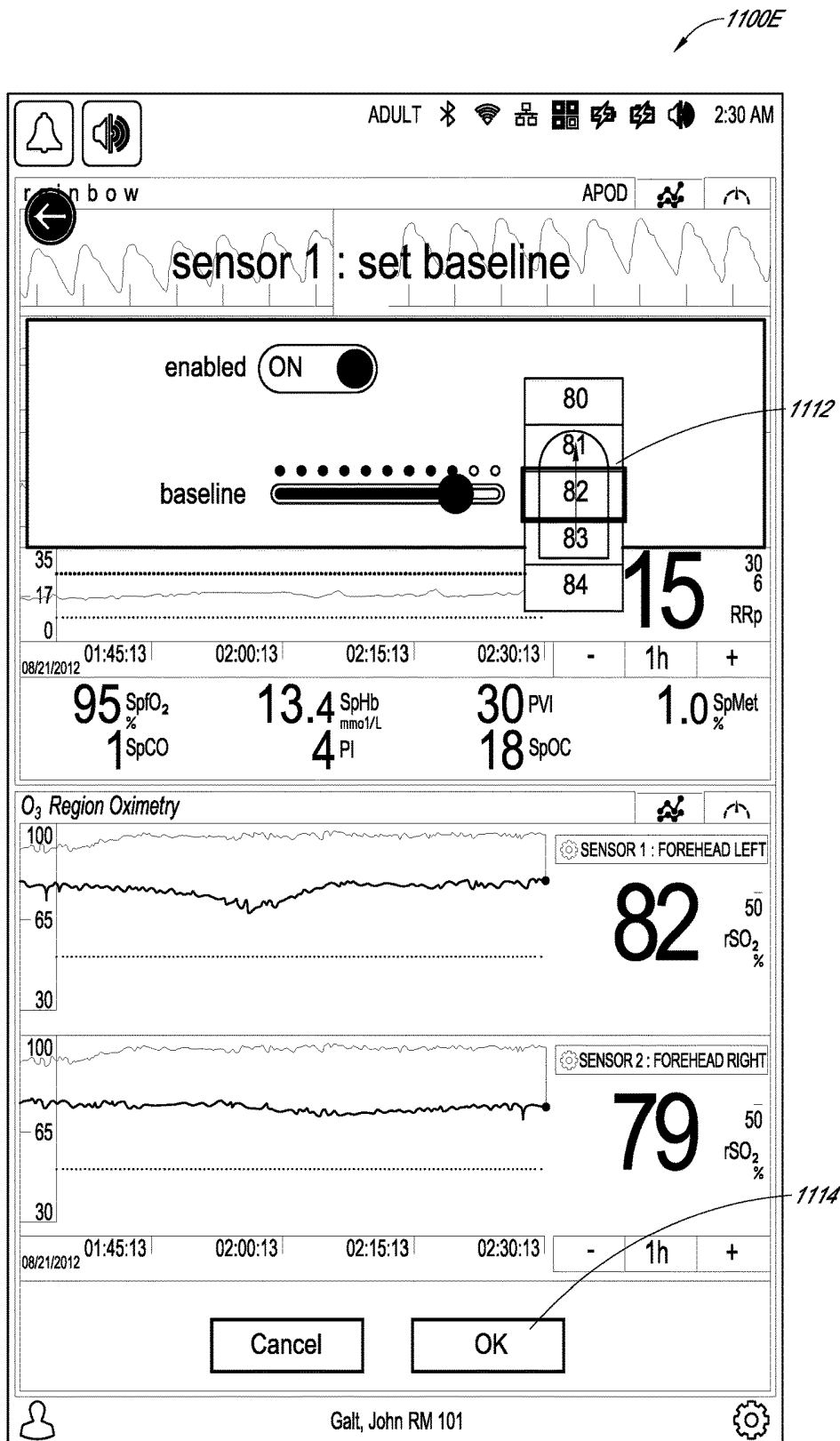

FIG. 11E

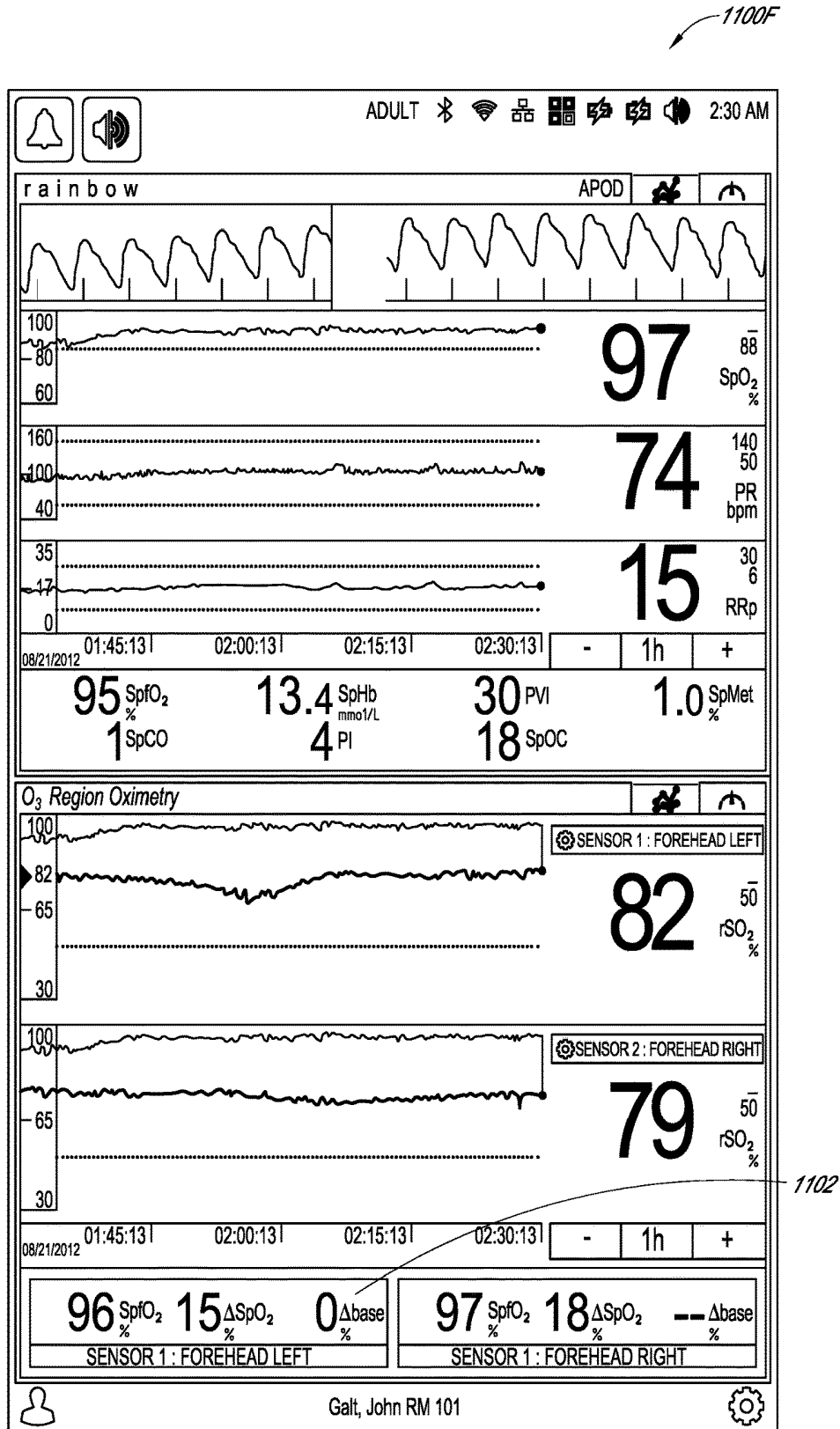

FIG. 11F

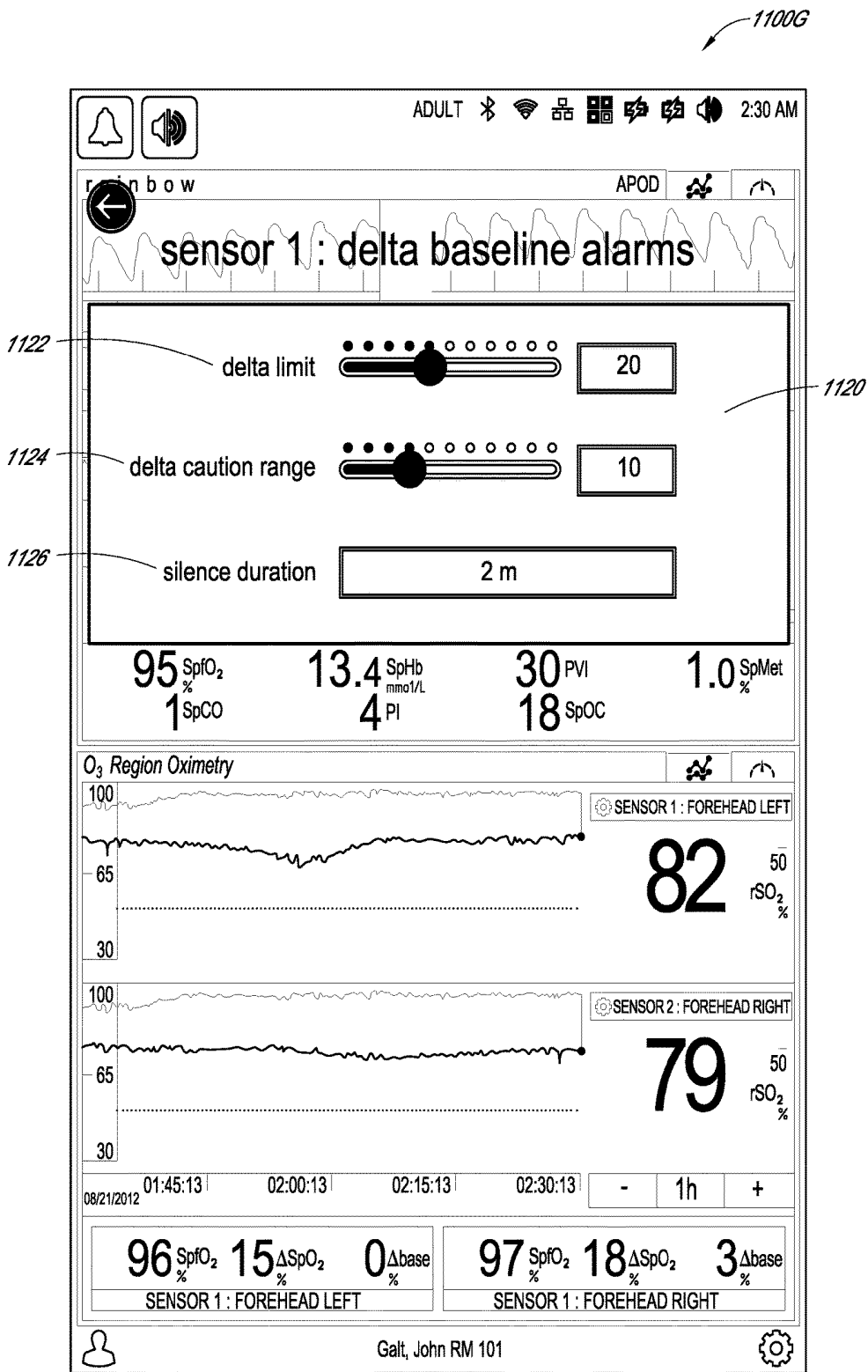

FIG. 11G

1200A

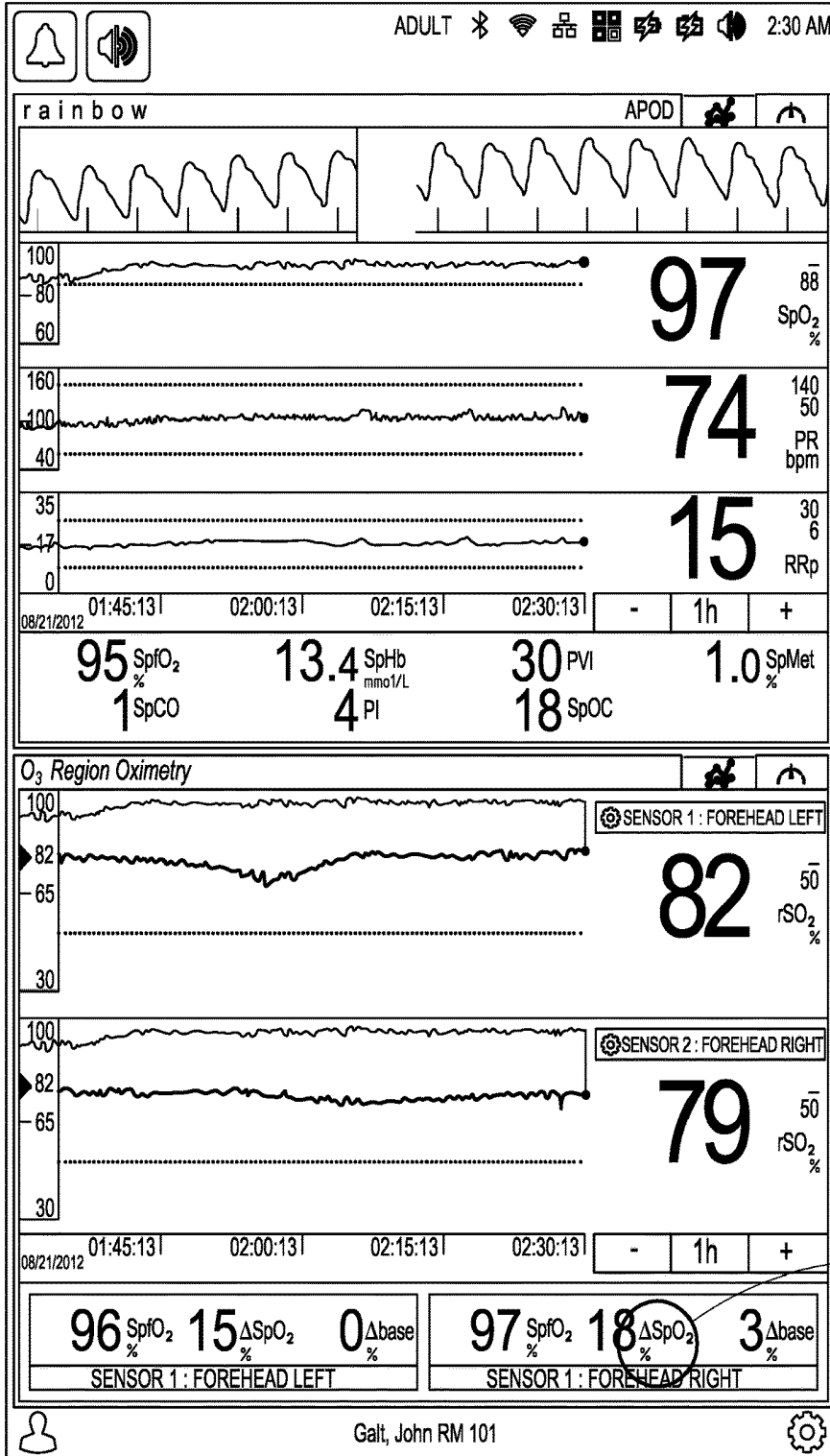

FIG. 12A

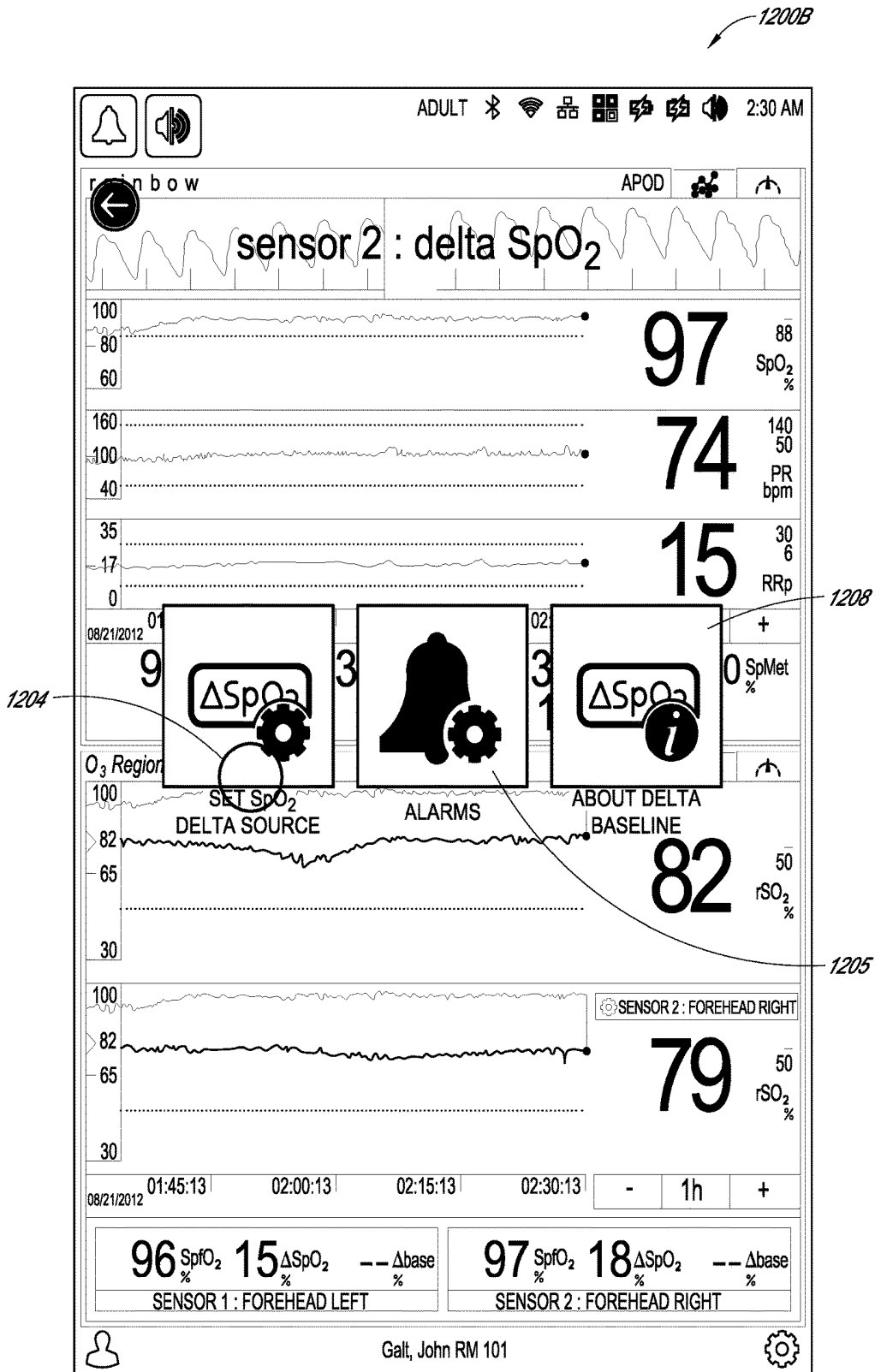

FIG. 12B

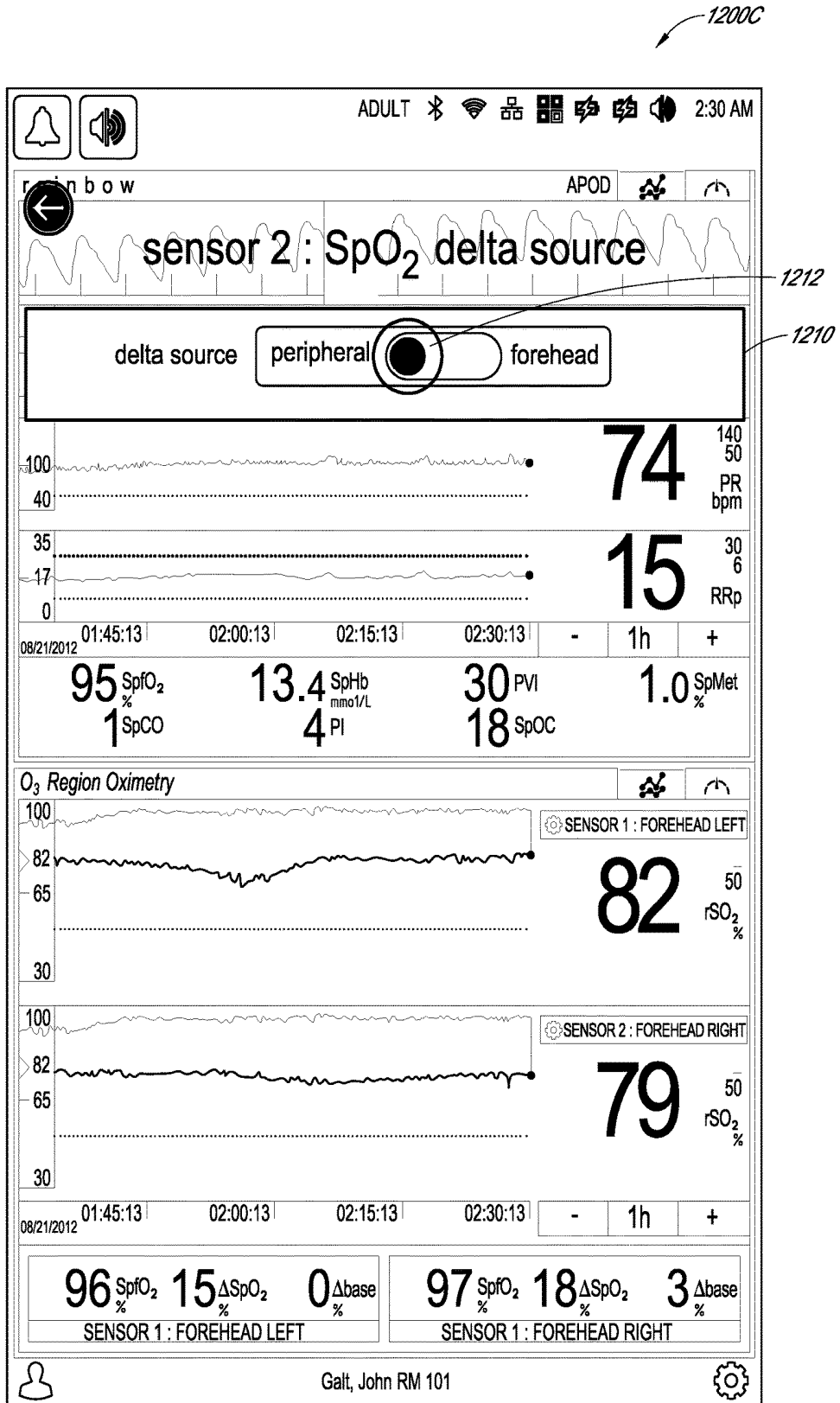

FIG. 12C

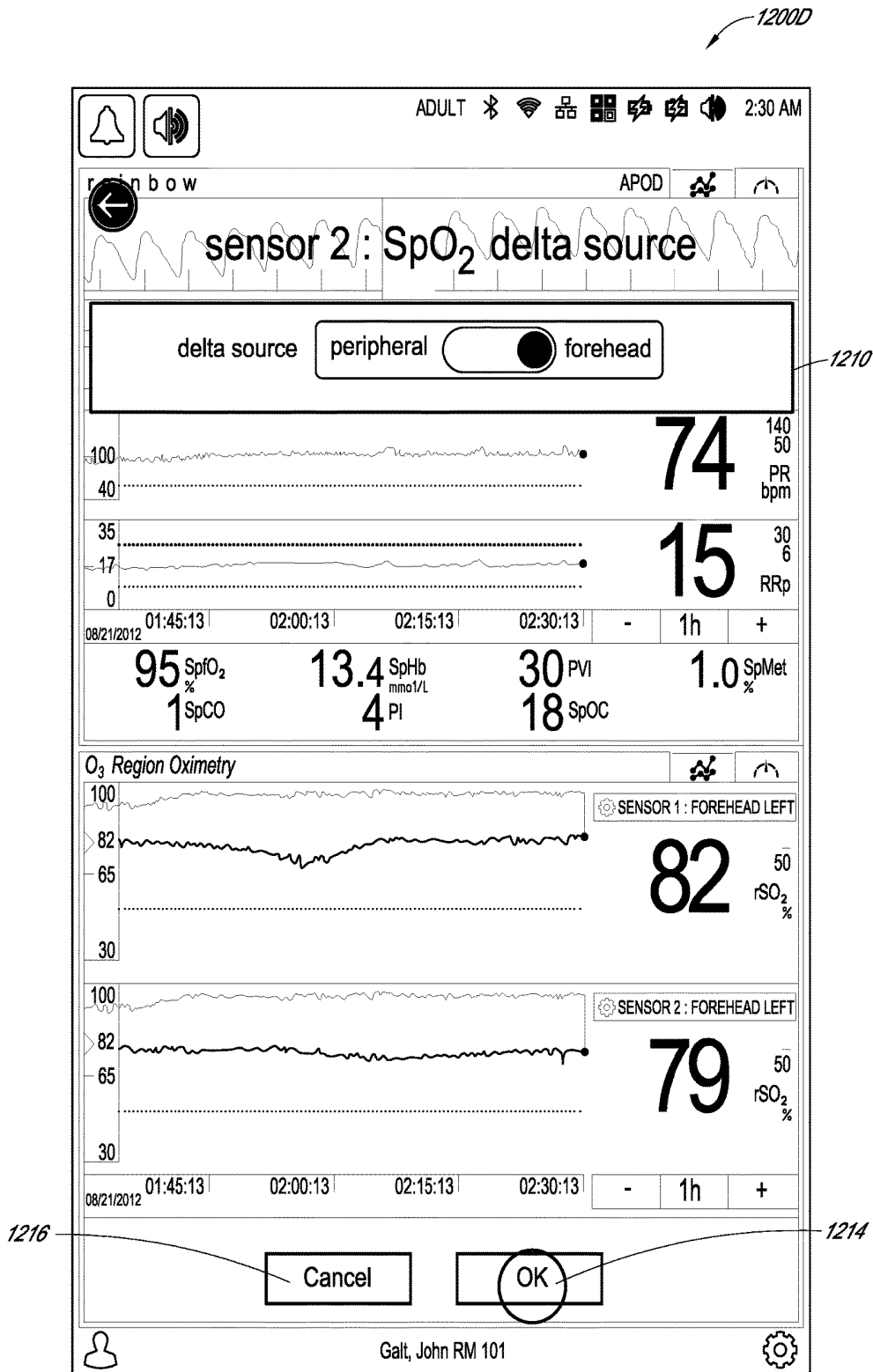

FIG. 12D

1200E

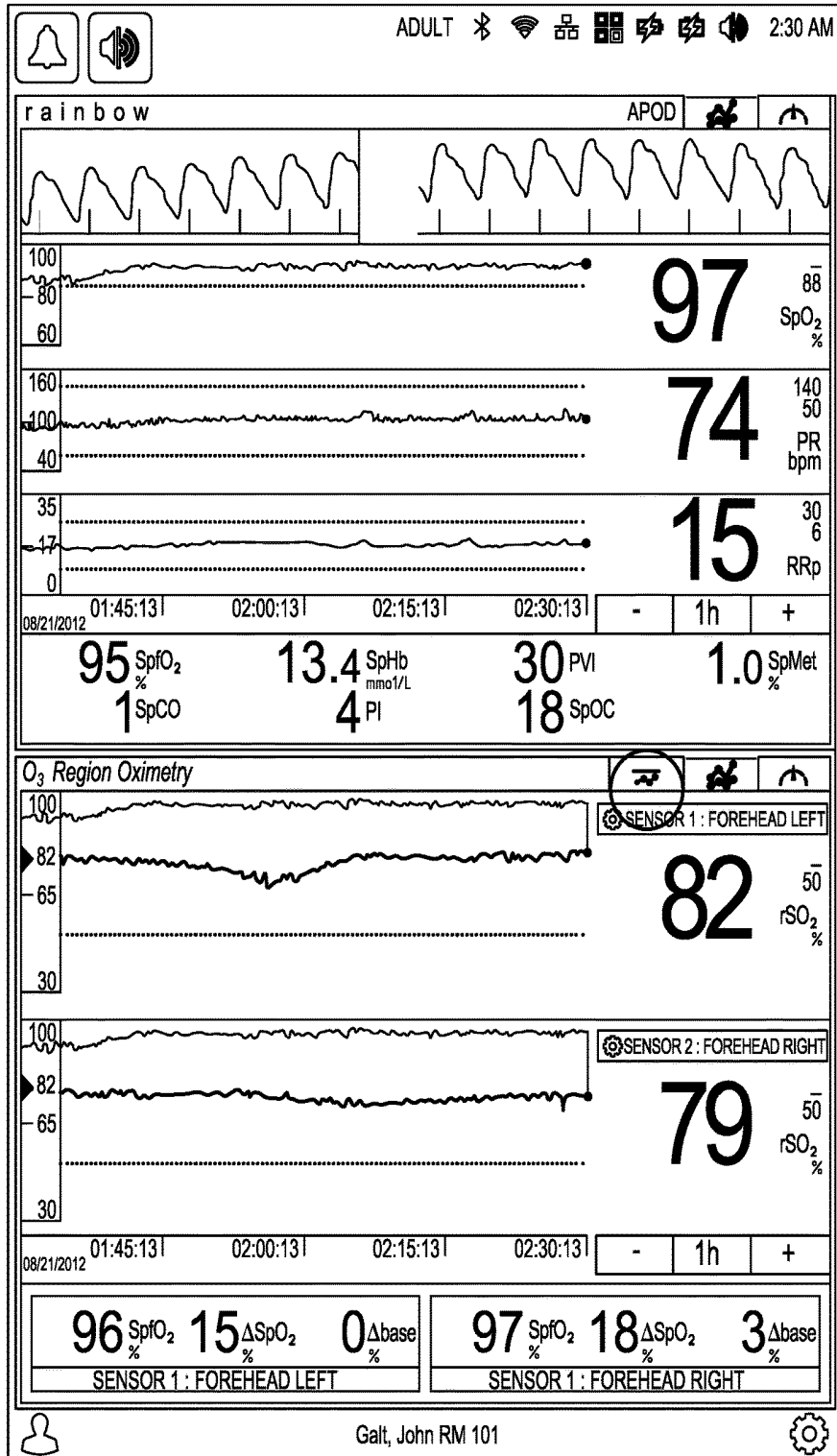

FIG. 12E

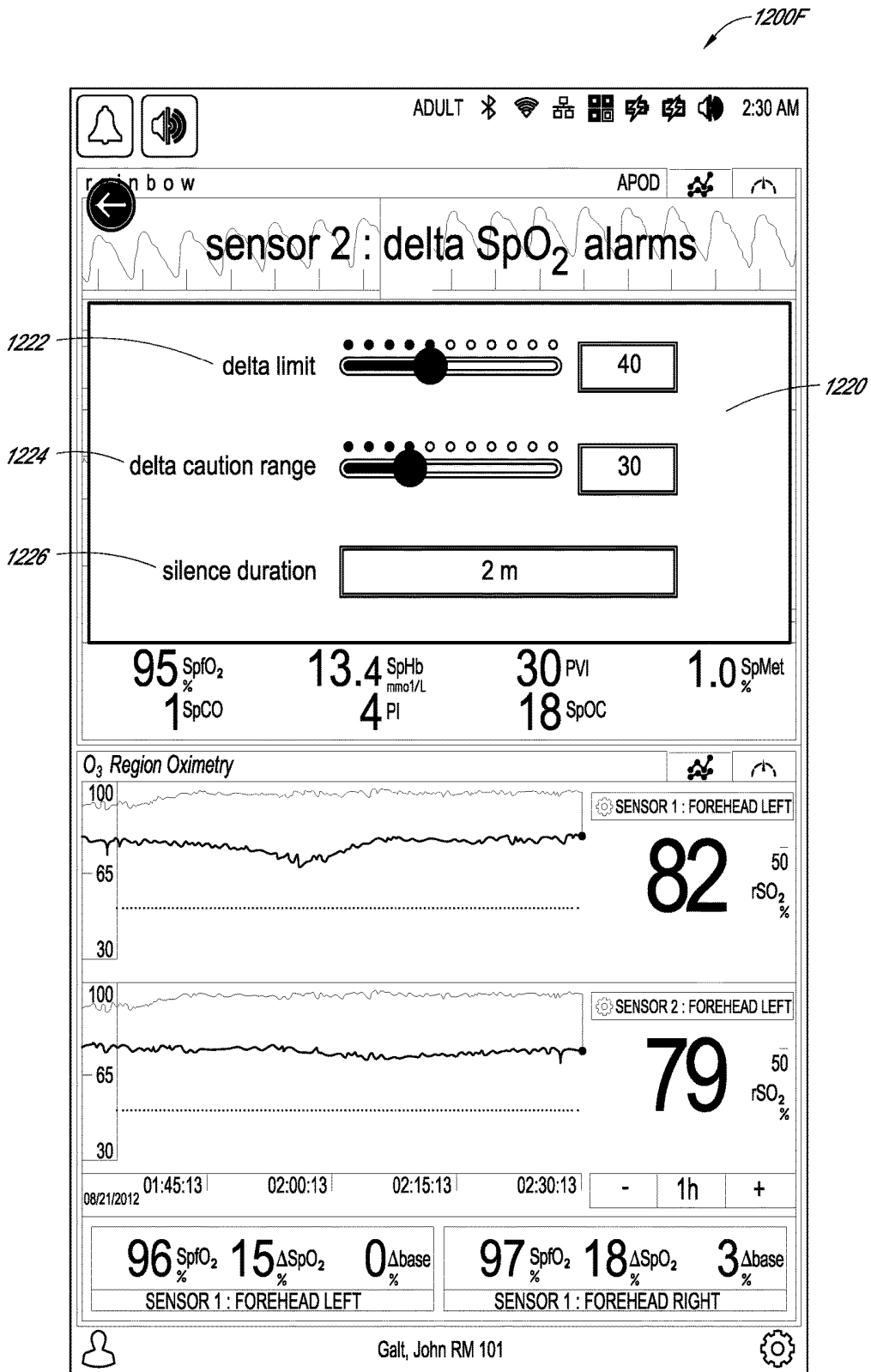

FIG. 12F

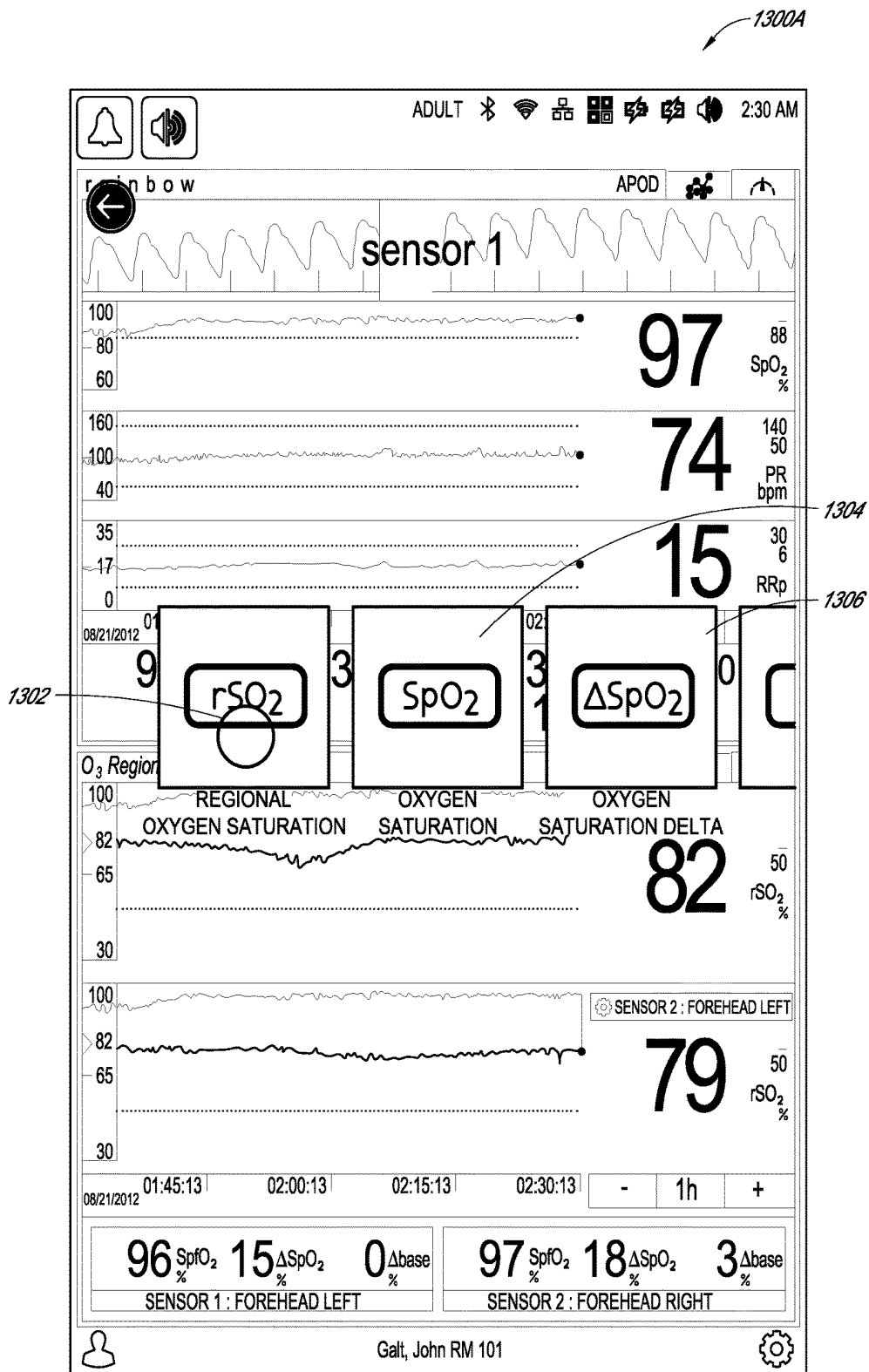

FIG. 13A

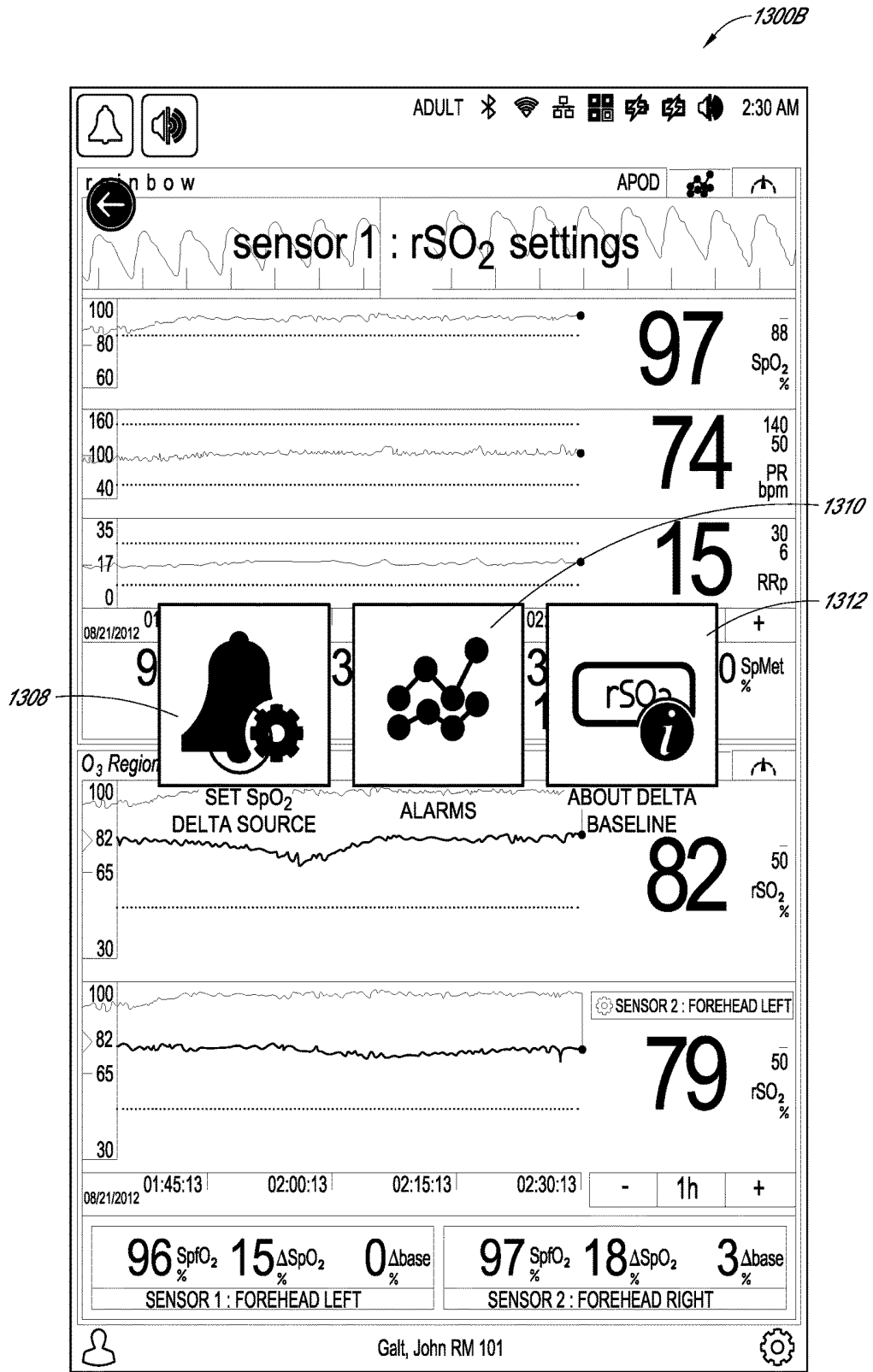

FIG. 13B

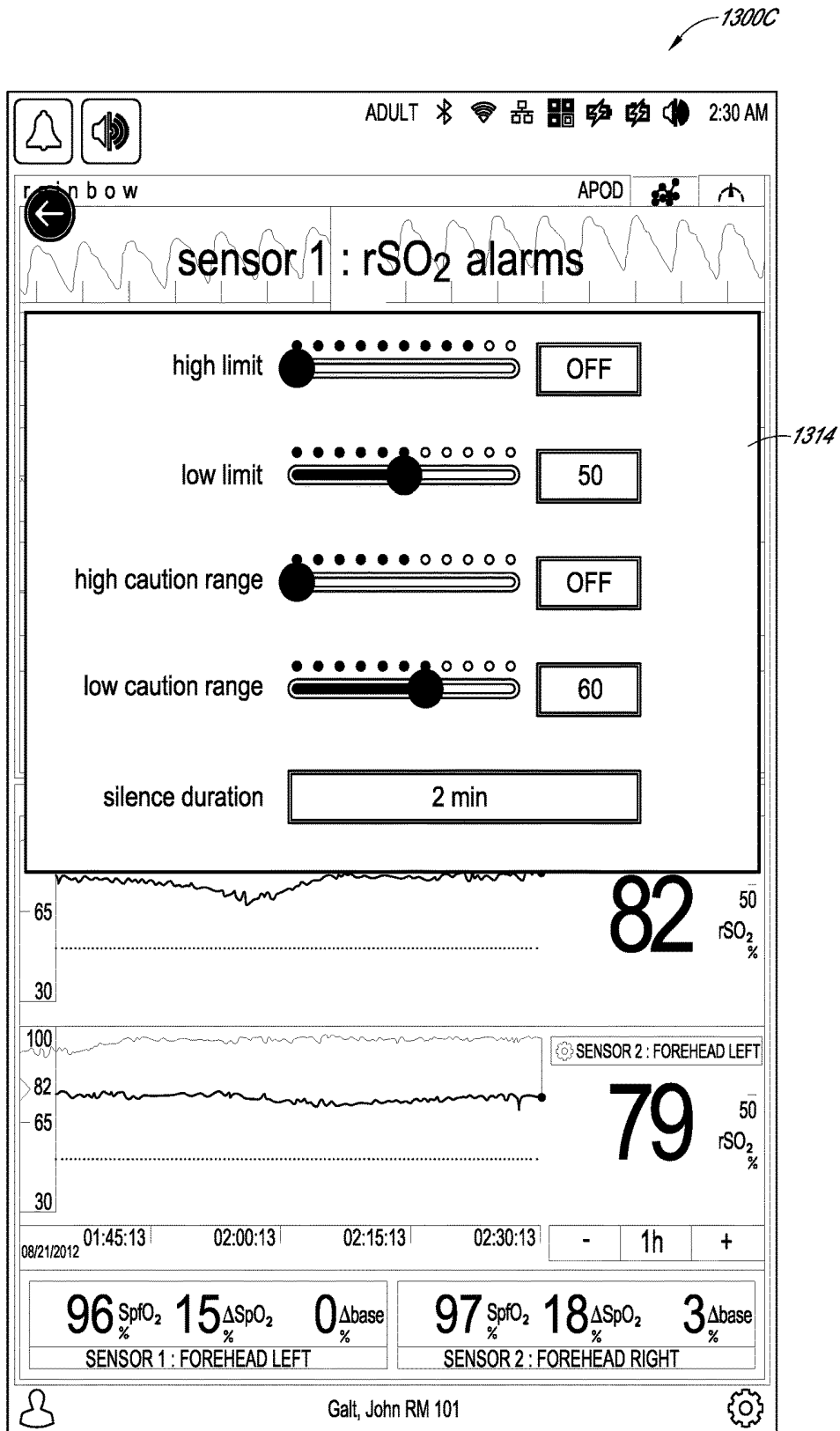

FIG. 13C

1300D

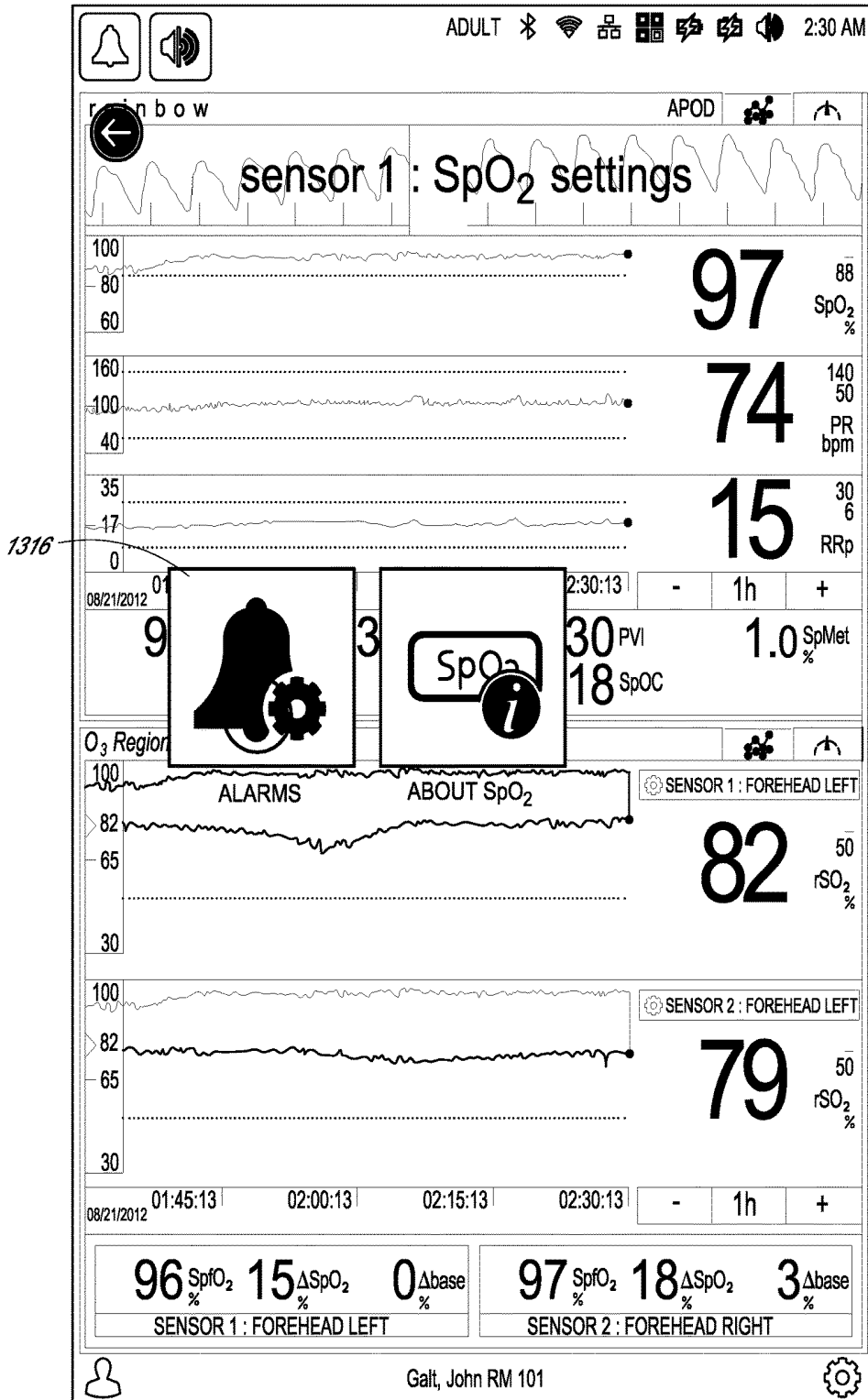

FIG. 13D

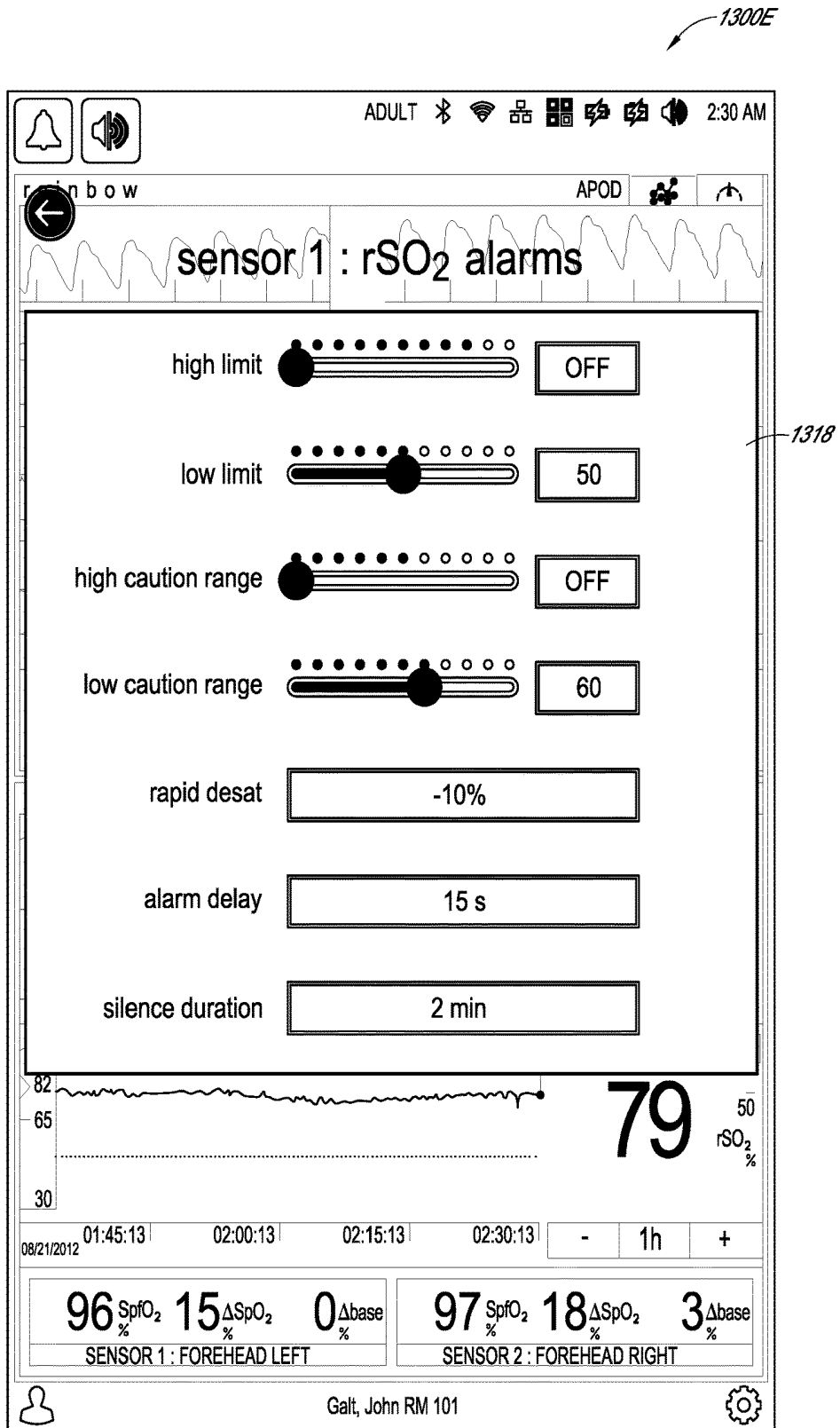

FIG. 13E

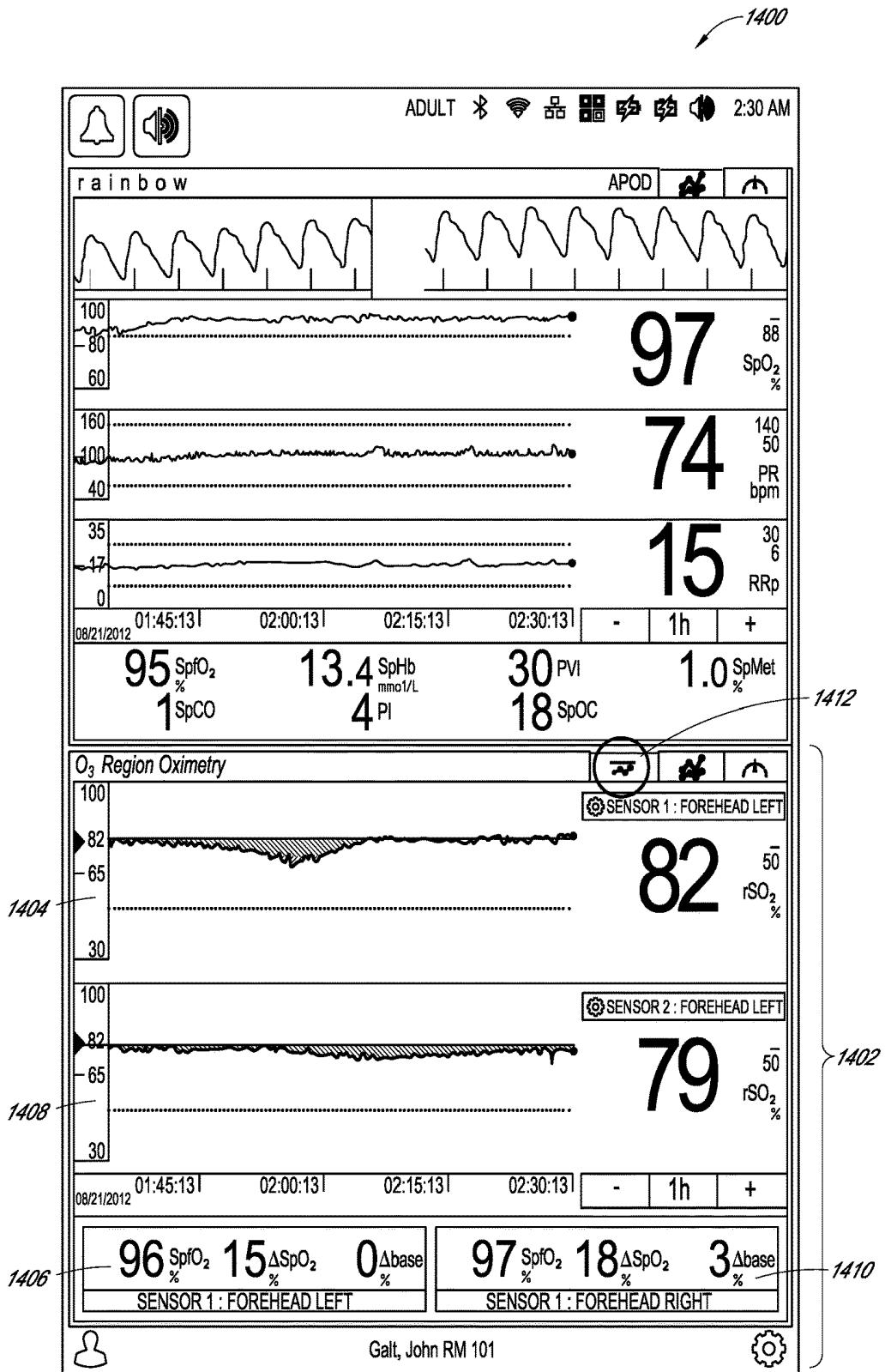

FIG. 14

1500A

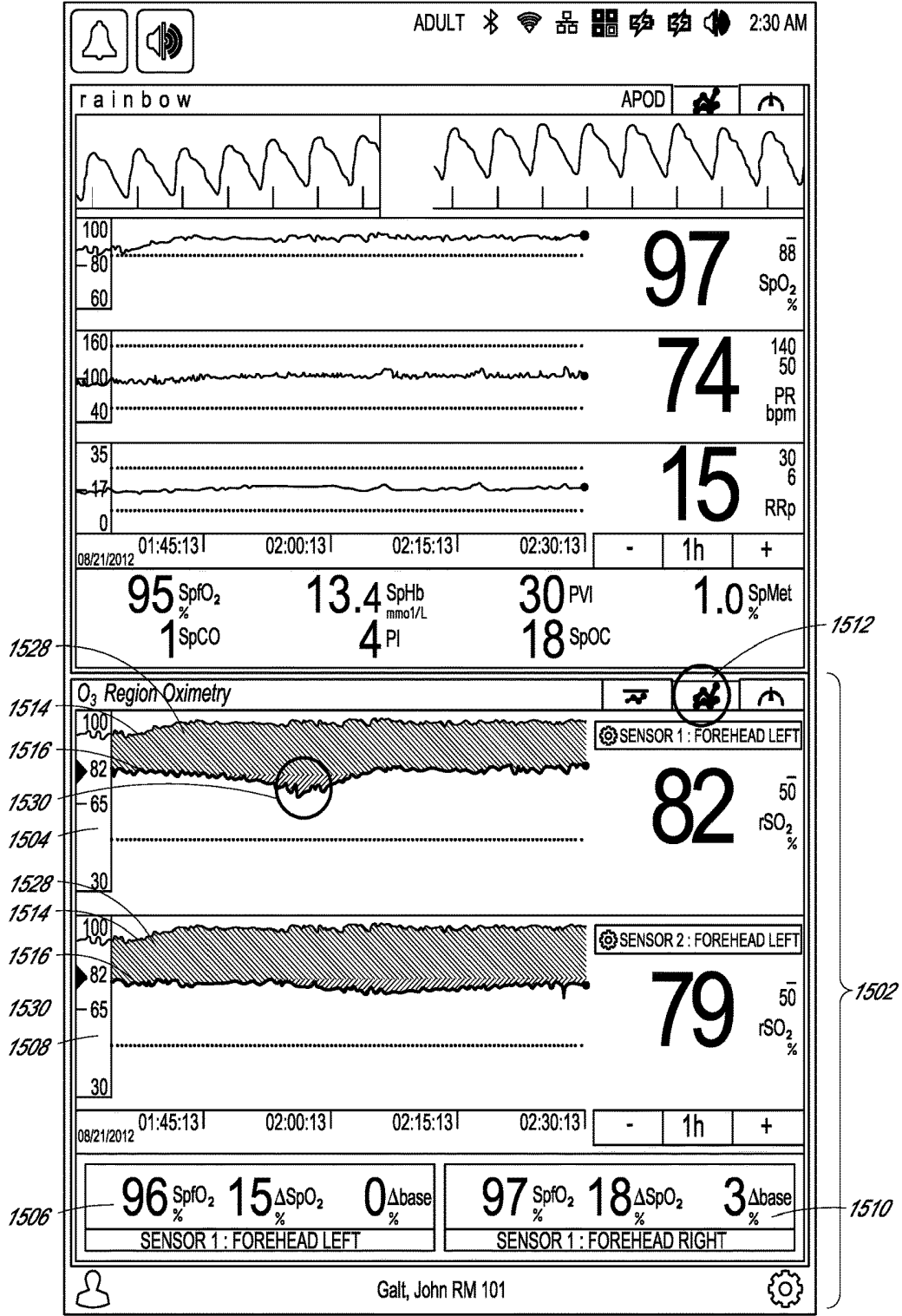

FIG. 15A

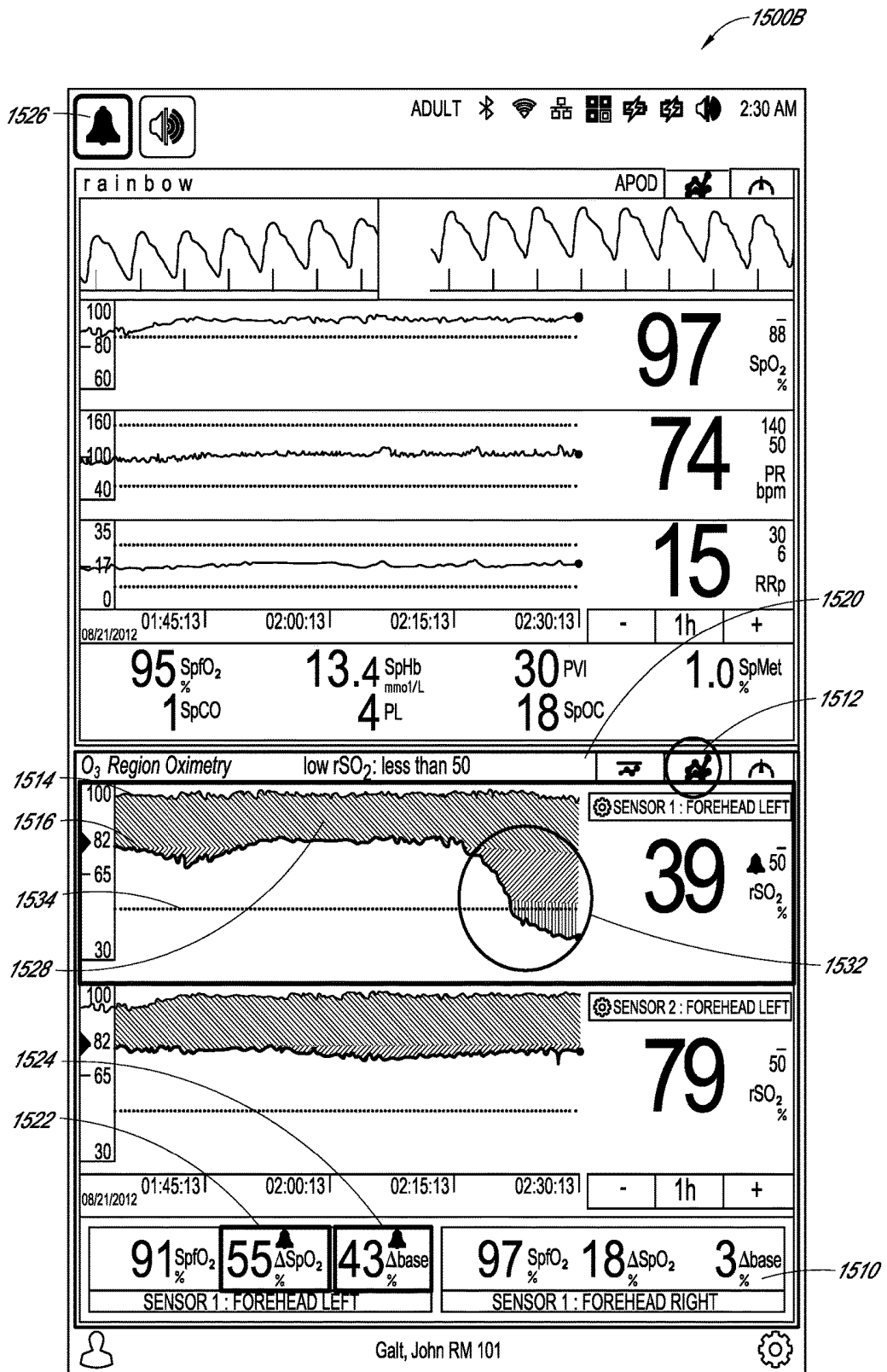

FIG. 15B

## REGIONAL OXIMETRY USER INTERFACE

### PRIORITY CLAIM AND RELATED APPLICATIONS

**[0001]** Any and all applications for which a foreign or domestic priority claim is identified in the Application Data Sheet as filed with the present application are hereby incorporated by reference under 37 CFR 1.57.

**[0002]** This application is a continuation of U.S. patent application Ser. No. 14/507,660, filed Oct. 6, 2014, which claims a priority benefit under 35 U.S.C. § 119 to the following U.S. Provisional Patent Applications:

Serial No.	Date	Title
61/887,856,	Oct. 7, 2013,	Regional Oximetry Sensor,
61/887,878,	Oct. 7, 2013,	Regional Oximetry Pod,
61/887,883,	Oct. 7, 2013,	Regional Oximetry User interface, and
62/012,170,	Jun. 13, 2014	Peel-Off Resistant Regional Oximetry Sensor.

**[0003]** Each of the foregoing disclosures is incorporated by reference herein in its entirety.

### FIELD OF THE DISCLOSURE

**[0004]** The present disclosure relates generally to patient monitoring devices and systems, and specifically to improving user interaction with a patient monitor and medical data communication hub.

### BACKGROUND OF THE DISCLOSURE

**[0005]** Regional oximetry, also referred to as tissue oximetry and cerebral oximetry, enables the continuous assessment of the oxygenation of tissue. The measurement is taken by placing one or more sensors on a patient, frequently on the patient's left and right forehead. Regional oximetry estimates regional tissue oxygenation by transcutaneous measurement of areas that are vulnerable to changes in oxygen supply and demand. Regional oximetry exploits the ability of light to penetrate tissue and determine hemoglobin oxygenation according to the amount of light absorbed by hemoglobin.

**[0006]** Regional oximetry differs from pulse oximetry in that tissue sampling represents primarily (70-75%) venous, and less (20-25%) arterial blood. The technique uses two photo-detectors with each light source, thereby allowing selective sampling of tissue beyond a specified depth beneath the skin. Near-field photo-detection is subtracted from far-field photo-detection to provide selective tissue oxygenation measurement beyond a pre-defined depth. Moreover, regional oximetry monitoring does not depend upon pulsatile flow.

**[0007]** Regional oximetry is a useful patient monitoring technique to alert clinicians to dangerous clinical conditions. Changes in regional oximetry have been shown to occur in the absence of changes in arterial saturation or systemic hemodynamic parameters.

### SUMMARY

**[0008]** The present disclosure provides a regional oximetry system with improved user interaction. In one aspect of the regional oximetry system, a display is provided, and a processor is provided causing a plurality of views to be

displayed on the display. The views are configured to occupy at least a portion of the display. In some embodiments a first sensor port is configured to receive a first physiological signal representative of a regional tissue oxygenation level. In some embodiments a second sensor port is configured to receive a second physiological signal representative of an arterial oxygen saturation level. In some embodiments, the views are adapted to present data responsive to at least one physiological signal. In some embodiments, one view presents a first trend graph of a first physiological signal representative of a regional tissue oxygenation level, and a second trend graph of a second physiological signal representative of an arterial oxygen saturation level. In some embodiments an area between the first trend graph and the second trend graph can include a differential analysis of regional-to-central oxygen saturation.

**[0009]** Another aspect of a regional oximetry system includes obtaining a first waveform responsive to a physiological signal representative of a regional tissue oxygenation level, obtaining a second waveform responsive to a physiological signal representative of an arterial oxygen saturation level, determining, using at least one processor, a data trend responsive to the first physiological signal, determining, using at least one processor, a data trend responsive to the second physiological signal, and determining, using the at least one processor, a difference between the data trend responsive to the first physiological signal and the data trend responsive to the second physiological signal. In some embodiments, the regional oximetry system further presents, in a first display view, the determined data trends responsive to the first and second physiological signals, and in a second display view, the determined difference between the data trend responsive to the first and second physiological signals.

**[0010]** Yet another aspect of a regional oximetry system is a display and a processor causing a plurality of views to be displayed on the display. In some embodiments the views are configured to occupy at least a portion of the display. The views are adapted to present data responsive to at least one physiological signal. In some embodiments a first sensor port is configured to receive a first physiological signal representative of a regional tissue oxygenation level. In some embodiments the processor is configured to set a baseline level representative of an acceptable state of the regional tissue oxygenation. One view, for example, can present a differential analysis of a physiological signal representative of a regional tissue oxygenation level and a baseline level representative of an acceptable state of regional tissue oxygenation.

**[0011]** In yet another aspect of a regional oximetry system a display is provided, a sensor port is provided that is adapted to communicate with at least one sensor, and a processor is provided causing a plurality of views to be displayed on the display. The views are configured to occupy at least a portion of the display. A set sensor menu view is configured to occupy at least a portion of the display and is adapted to present a connectivity status of the sensor port and the at least one sensor.

**[0012]** For purposes of summarizing the disclosure, certain aspects, advantages, and novel features have been described herein. Of course, it is to be understood that not necessarily all such aspects, advantages, or features will be embodied in any particular embodiment.

## BRIEF DESCRIPTION OF THE DRAWINGS

**[0013]** The following drawings and the associated descriptions are provided to illustrate embodiments of the present disclosure and do not limit the scope of the claims.

**[0014]** FIGS. 1A-1C are perspective views of a medical monitoring hub;

**[0015]** FIG. 2 is a simplified block diagram of a medical monitoring environment;

**[0016]** FIG. 3 is a simplified hardware block diagram of a medical monitoring system;

**[0017]** FIG. 4 is a finger control gesture legend for a touchscreen interface;

**[0018]** FIG. 5 is an illustration of a display view;

**[0019]** FIGS. 6A-6B are illustrations of potential regional oximetry sensor site locations for an adult and for a child, respectively;

**[0020]** FIG. 7 is an illustration of a regional oximetry display;

**[0021]** FIG. 8 is an illustration of a medical monitoring hub display;

**[0022]** FIGS. 9A-9B illustrate embodiments for regional oximetry monitoring;

**[0023]** FIGS. 10A-10F illustrate embodiments of a user interface for selecting a regional oximetry sensor site;

**[0024]** FIGS. 11A-11G illustrate embodiments of a user interface for setting a baseline for a regional oximetry sensor;

**[0025]** FIGS. 12A-12F illustrate embodiments of a user interface for setting a source for measuring arterial oxygen saturation;

**[0026]** FIGS. 13A-13E illustrate embodiments of a user interface for setting parameters of a sensor used in a regional oximetry system;

**[0027]** FIG. 14 illustrates an embodiment of a display of regional oximetry baseline delta measurements; and

**[0028]** FIGS. 15A-15B illustrate embodiments of a display of regional-to-central oxygenation saturation measurements.

**[0029]** While the foregoing "Brief Description of the Drawings" references generally various embodiments of the disclosure, an artisan will recognize from the disclosure herein that such embodiments are not mutually exclusive. Rather, the artisan would recognize a myriad of combinations of some or all of such embodiments.

## DETAILED DESCRIPTION

**[0030]** The following description is merely illustrative in nature and is in no way intended to limit the disclosure, its application, or uses. For purposes of clarity, the same reference numbers will be used in the drawings to identify similar elements. It should be understood that steps within a method may be executed in different order without altering the principles of the present disclosure.

**[0031]** The present disclosure relates to a user interface for a medical monitoring hub configured to be the center of monitoring activity for a given patient. An example of a medical monitoring hub is disclosed in U.S. patent application Ser. No. 13/651,167 assigned to the assignee of the present disclosure, and is incorporated by reference herein.

**[0032]** In an embodiment, the hub comprises a large, easily-readable display, such as an about ten (10) inch display dominating the majority of real estate on a front face of the hub. The display could be much larger or much

smaller depending upon design constraints. However, for portability and current design goals, the preferred display is roughly sized proportional to the vertical footprint of one of the dockable portable patient monitors. Other considerations are recognizable by those skilled in the art from the disclosure herein.

**[0033]** The display provides measurement data for a wide variety of monitored parameters for the patient under observation in numerical or graphic form. In various embodiments, the measurement data is automatically configured based on the type of data and information being received at the hub. In an embodiment, the hub is moveable, portable, and mountable so that it can be positioned to convenient areas within a caregiver environment. For example, the hub is collected within a singular housing.

**[0034]** In an embodiment, the hub may advantageously receive data from a portable patient monitor while docked or undocked from the hub. Typical portable patient monitors, such as oximeters or co-oximeters can provide measurement data for a large number of physiological parameters derived from signals output from optical and/or acoustic sensors, electrodes, or the like. The physiological parameters include, but are not limited to oxygen saturation (including arterial blood oxygenation, regional oximetry (also known as tissue oximetry and cerebral oximetry), carboxyhemoglobin, methemoglobin, total hemoglobin, glucose, pH, bilirubin, fractional saturation, pulse rate, respiration rate, components of a respiration cycle, indications of perfusion including perfusion index, signal quality and/or confidences, plethysmograph data, indications of wellness or wellness indexes or other combinations of measurement data, audio information responsive to respiration, ailment identification or diagnosis, blood pressure, patient and/or measurement site temperature, depth of sedation, organ or brain oxygenation, hydration, measurements responsive to metabolism, combinations of the same or the like, to name a few. In other embodiments, the hub may output data sufficient to accomplish closed-loop drug administration in combination with infusion pumps or the like.

**[0035]** In an embodiment, the hub communicates with other devices that are interacting with the patient in a number of ways in a monitoring environment. For example, the hub advantageously receives serial data from other devices without necessitating their reprogramming or that of the hub. Such other devices include pumps, ventilators, all manner of monitors monitoring any combination of the foregoing parameters, ECG/EEG/EKG devices, electronic patient beds, and the like. Moreover, the hub advantageously receives channel data from other medical devices without necessitating their reprogramming or that of the hub. When a device communicates through channel data, the hub may advantageously alter the large display to include measurement information from that device. Additionally, the hub accesses call systems, such as those used by nurses or other attendants, to ensure that call situations from the device are passed to the appropriate nurse or attendant call system.

**[0036]** The hub also communicates with hospital systems to advantageously associate incoming patient measurement and treatment data with the patient being monitored. For example, the hub may communicate wirelessly or otherwise to a multi-patient monitoring system, such as a server or collection of servers, which in turn may communicate with a caregiver's data management systems, such as, for example, an Admit, Discharge, Transfer ("ADT") system

and/or an Electronic Medical Records (“EMR”) system. The hub advantageously associates the data flowing through it with the patient being monitored, thereby providing the electronic measurement and treatment information to be passed to the caregiver’s data management systems without the caregiver associating each device in the environment with the patient.

**[0037]** In an embodiment, the hub advantageously includes a reconfigurable and removable docking station. The docking station may dock additional layered docking stations to adapt to different patient monitoring devices. Additionally, the docking station itself is modularized so that it may be removed if the primary dockable portable patient monitor changes its form factor. Thus, the hub is flexible in how its docking station is configured.

**[0038]** In an embodiment, the hub includes a large memory for storing some or all of the data it receives, processes, and/or associates with the patient, and/or communications it has with other devices and systems. Some or all of the memory may advantageously comprise removable SD memory.

**[0039]** The hub communicates with other devices through at least (1) the docking station to acquire data from a portable monitor, (2) innovative universal medical connectors to acquire channel data, (3) serial data connectors, such as RJ ports to acquire output data, (4) Ethernet, USB, and nurse call ports, (5) Wireless devices to acquire data from a portable monitor, and (6) other wired or wireless communication mechanisms known to an artisan. The universal medical connectors advantageously provide optional electrically-isolated power and communications, and are designed to be smaller in cross section than other commonly-used isolation configurations. The connectors and the hub communicate to advantageously translate or configure data from other devices to be usable and displayable for the hub. In an embodiment, a software developers kit (“SDK”) is provided to a device manufacturer to establish or define the behavior and meaning of the data output from their device. When the output is defined, the definition is programmed into a memory residing in the cable side of the universal medical connector and supplied as an original equipment manufacturer (“OEM”) to the device provider. When the cable is connected between the device and the hub, the hub understands the data and can use it for display and processing purposes without necessitating software upgrades to the device or the hub. In an embodiment, the hub can negotiate the schema and even add additional compression and/or encryption. Through the use of the universal medical connectors, the hub organizes the measurement and treatment data into a single display and alarm system effectively and efficiently, bringing order to the monitoring environment.

**[0040]** As the hub receives and tracks data from other devices according to a channel paradigm, the hub may advantageously provide processing to create virtual channels of patient measurement or treatment data. In an embodiment, a virtual channel may comprise a non-measured parameter that is, for example, the result of processing data from various measured or other parameters. An example of such a parameter includes a wellness indicator derived from various measured parameters that give an overall indication of the wellbeing of the monitored patient. An example of a wellness parameter is disclosed in U.S. patent application Ser. Nos. 13/269,296, 13/371,767 and 12/904,925, by the

assignee of the present disclosure and incorporated by reference herein. By organizing data into channels and virtual channels, the hub may advantageously time-wise synchronize incoming data and virtual channel data.

**[0041]** The hub also receives serial data through serial communication ports, such as RJ connectors. The serial data is associated with the monitored patient and passed on to the multi-patient server systems and/or caregiver backend systems discussed above. Through receiving the serial data, the caregiver advantageously associates devices in the caregiver environment, often from varied manufacturers, with a particular patient, avoiding a need to have each individual device associated with the patient communicating independently with hospital systems. Such association is vital as it reduces caregiver time spent entering biographic and demographic information about the patient into each device. Moreover, in an embodiment, through the SDK the device manufacturer may advantageously provide information associated with any measurement delay of their device, thereby further allowing the hub to advantageously time-wise synchronize serial incoming data and other data associated with the patient.

**[0042]** In an embodiment, when a portable patient monitor is docked, and it includes its own display, the hub effectively increases its display real estate. For example, in an embodiment, the portable patient monitor may simply continue to display its measurement and/or treatment data, which may be now duplicated on the hub display, or the docked display may alter its display to provide additional information. In an embodiment, the docked display, when docked, presents anatomical graphical data of, for example, the heart, lungs, organs, the brain, or other body parts being measured and/or treated. The graphical data may advantageously animate similar to and in concert with the measurement data. For example, lungs may inflate in approximate correlation to the measured respiration rate and/or the determined inspiration/expiration portions of a respiration cycle; the heart may beat according to the pulse rate or along generally understood actual heart contraction patterns; the brain may change color or activity based on varying depths of sedation; or the like. In an embodiment, when the measured parameters indicate a need to alert a caregiver, a changing severity in color may be associated with one or more displayed graphics, such as the heart, lungs, brain, organs, circulatory system or portions thereof, respiratory system or portions thereof, other body parts or the like. In still other embodiments, the body portions may include animations on where, when or how to attach measurement devices.

**[0043]** The hub may also advantageously overlap parameter displays to provide additional visual information to the caregiver. Such overlapping may be user definable and configurable. The display may also incorporate analog-appearing icons or graphical indicia.

**[0044]** In the interest of clarity, not all features of an actual implementation are described in this specification. An artisan will of course appreciate that in the development of any such actual implementation (as in any development project), numerous implementation-specific decisions must be made to achieve a developer’s specific goals and sub-goals, such as compliance with system and business-related constraints, which will vary from one implementation to another. Moreover, it will be appreciated that such a development effort might be complex and time-consuming, but would never-

theless be a routine undertaking of device and systems engineering for those of ordinary skill having the benefit of this disclosure.

[0045] To facilitate a complete understanding of the disclosure, the remainder of the detailed description describes the disclosure with reference to the drawings, wherein like reference numbers are referenced with like numerals throughout.

[0046] FIG. 1A illustrates a perspective view of an embodiment of a medical monitoring hub 100 with an embodiment of a docked portable patient monitor 102 according to an embodiment of the disclosure. The hub 100 includes a display 104, and a docking station 106, which in an embodiment is configured to mechanically and electrically mate with the portable patient monitor 102, each housed in a movable, mountable and portable housing 108. The housing 108 includes a generally upright inclined shape configured to rest on a horizontal flat surface, although the housing 108 can be affixed in a wide variety of positions and mountings and comprise a wide variety of shapes and sizes.

[0047] In an embodiment, the display 104 may present a wide variety of measurement and/or treatment data in numerical, graphical, waveform, or other display indicia 110. In an embodiment, the display 104 occupies much of a front face of the housing 108, although an artisan will appreciate the display 104 may comprise a tablet or tabletop horizontal configuration, a laptop-like configuration or the like. Other embodiments may include communicating display information and data to a table computer, smartphone, television, or any display system recognizable to an artisan. The upright inclined configuration of FIG. 1A presents display information to a caregiver in an easily viewable manner.

[0048] FIG. 1B shows a perspective side view of an embodiment of the hub 100 including the housing 108, the display 104, and the docking station 106 without a portable monitor docked. Also shown is a connector for noninvasive blood pressure (NIBP) 113.

[0049] In an embodiment, the housing 108 may also include pockets or indentations to hold additional medical devices, such as, for example, a blood pressure monitor or temperature sensor 112, such as that shown in FIG. 1C.

[0050] The portable patient monitor 102 of FIG. 1A may advantageously comprise an oximeter, co-oximeter, respiratory monitor, depth of sedation monitor, noninvasive blood pressure monitor, vital signs monitor or the like, such as those commercially available from Masimo Corporation of Irvine, Calif., and/or disclosed in U.S. Pat. Nos. 2002/0140675, 2010/0274099, 2011/0213273, 2012/0226117, 2010/0030040; U.S. Pat. App. Ser. Nos. 61/242,792, 61/387457, 61/645,570, Ser. No. 13/554,908 and U.S. Pat. Nos. 6,157,850, 6,334,065, and the like. The portable patient monitor 102 may communicate with a variety of noninvasive and/or minimally invasive devices such as optical sensors with light emission and detection circuitry, acoustic sensors, devices that measure blood parameters from a finger prick, cuffs, ventilators, and the like. The portable patient monitor 102 may include its own display 114 presenting its own display indicia 116. The display indicia 116 may advantageously change based on a docking state of the portable patient monitor 102. When undocked, the display indicia 116 may include parameter information and may alter orientation based on information provided by, for example, a gravity sensor or an accelerometer.

[0051] In an embodiment, the docking station 106 of the hub 100 includes a mechanical latch 118, or a mechanically releasable catch to ensure that movement of the hub 100 doesn't mechanically detach the portable patient monitor 102 in a manner that could damage the same.

[0052] Although disclosed with reference to particular portable patient monitors 102, an artisan will recognize from the disclosure herein there is a large number and wide variety of medical devices that may advantageously dock with the hub 100. Moreover, the docking station 106 may advantageously electrically and not mechanically connect with the monitor 102, and/or wirelessly communicate with the same.

[0053] FIG. 2 illustrates a simplified block diagram of a monitoring environment 200 including the hub 100 of FIGS. 1A-1C, according to an embodiment of the disclosure. As shown in FIG. 2, the environment may include the portable patient monitor 102 communicating with one or more patient sensors 202, such as, for example, oximetry optical sensors, acoustic sensors, blood pressure sensors, respiration sensors or the like. In an embodiment, additional sensors, such as, for example, a NIBP sensor or system 211 and a temperature sensor or sensor system 213 may communicate directly with the hub 100. The sensors 202, 211 and 213 when in use are typically in proximity to the patient being monitored if not actually attached to the patient at a measurement site.

[0054] As disclosed, the portable patient monitor 102 communicates with the hub 100, in an embodiment, through the docking station 106 when docked and, in an embodiment, wirelessly when undocked, however, such undocked communication is not required. The hub 100 communicates with one or more multi-patient monitoring servers 204 or server systems, such as, for example, those disclosed with in U.S. Pat. Pub. Nos. 2011/0105854, 2011/0169644, and 2007/0180140. In general, the server 204 communicates with caregiver backend systems 206 such as EMR and/or ADT systems. The server 204 may advantageously obtain through push, pull or combination technologies patient information entered at patient admission, such as demographical information, billing information, and the like. The hub 100 accesses this information to seamlessly associate the monitored patient with the caregiver backend systems 206. Communication between the server 204 and the monitoring hub 100 may be accomplished by any technique recognizable to an artisan from the disclosure herein, including wireless, wired, over mobile or other computing networks, or the like.

[0055] FIG. 2 also shows the hub 100 communicating through its serial data ports 210 and channel data ports 212. As disclosed in the forgoing, the serial data ports 210 may provide data from a wide variety of patient medical devices, including electronic patient bed systems 214, infusion pump systems 216 including closed-loop control systems, ventilator systems 218, blood pressure or other vital sign measurement systems 220, or the like. Similarly, the channel data ports 212 may provide data from a wide variety of patient medical devices, including any of the foregoing, and other medical devices. For example, the channel data ports 212 may receive data from depth of consciousness monitors 222, such as those commercially available from Masimo Corporation of Irvine, Calif. under the SEDLine® and under the O<sub>3</sub>™ Regional Oximetry for the Root™ Patient Monitoring and Connectivity Platform™ brand names, brain or

other organ oximetry devices **224**, noninvasive blood pressure or acoustic devices **226**, or the like. In an embodiment, a device that is connected to the hub **100** through one or more of the channel data ports **212** may include board-in-cable (“BIC”) solutions, where the processing algorithms and the signal processing devices that accomplish those algorithms are mounted to a board housed in a cable or cable connector, which in some embodiments has no additional display technologies. The BIC solution outputs its measured parameter data to the channel port **212** to be displayed on the display **104** of hub **100**. In an embodiment, the hub **100** may advantageously be entirely or partially formed as a BIC solution that communicates with other systems, such as, for example, tablets, smartphones, or other computing systems.

[0056] Although illustrated with reference to a single docking station **106**, the environment **200** may include multiple, stacked docking stations where a subsequent docking station mechanically and electrically docks to a first docking station to change the form factor for a different portable patient monitor. Such stacking may include more than 2 docking stations, and may reduce or increase the form factor for mechanical compliance with mating mechanical structures on a portable device.

[0057] FIG. 3 illustrates a simplified hardware block diagram of the hub **100** of FIGS. 1A-1C, according to an embodiment of the disclosure. As shown in FIG. 3, the housing **108** of the hub **100** positions and/or encompasses an instrument board **302**, the display **104**, memory **304**, and the various communication connections, including the serial ports **210**, the channel ports **212**, Ethernet ports **305**, nurse call port **306**, other communication ports **308** including standard USB or the like, and the docking station interface **310**. The instrument board **302** comprises one or more substrates including communication interconnects, wiring, ports and the like to enable the communications and functions described herein, including inter-board communications. A core board **312** includes the main parameter, signal, and other processor(s) and memory. A portable patient monitor board (“RIB”) **314** includes patient electrical isolation for the portable patient monitor **102** and one or more processors. A channel board (“MID”) **316** controls the communication with the channel ports **212**, including optional patient electrical isolation and power supply **318**. A radio board **320** includes components configured for wireless communications. Additionally, the instrument board **302** may advantageously include one or more processors and controllers, busses, all manner of communication connectivity and electronics, memory, memory readers including EPROM readers, and other electronics recognizable to an artisan from the disclosure herein. Each board comprises substrates for positioning and support, interconnect for communications, electronic components including controllers, logic devices, hardware/software combinations and the like to accomplish the tasks designated above and others.

[0058] An artisan will recognize from the disclosure herein that the instrument board **302** may comprise a large number of electronic components organized in a large number of ways. Using different boards such as those disclosed above advantageously provides organization and compartmentalization to the complex system.

[0059] Attention is now directed to embodiments of a user interface by which a user may interact with the hub **100**. In particular, a touchscreen display **104** is integral to the hub **100**. An example of a physiological monitor touchscreen

interface is disclosed in U.S. patent application Ser. No. 13/850,000, assigned to the assignee of the present disclosure, and is incorporated by reference herein.

[0060] In general, the touchscreen interface provides an intuitive, gesture-oriented control for the hub **100**. The touchscreen interface employs interface constructs on the touchscreen display **104** that are particularly adapted to finger control gestures so as to change at least one of a physiological monitor operating characteristic and a physiological touchscreen display characteristic. In particular, the touchscreen display **104** presents a user with interface constructs responsive to finger control gestures so as to change displays and settings, such as monitor operating characteristics, display contents and display formats.

[0061] FIG. 4 illustrates a legend of finger control gestures **400** for use with a touchscreen display **104** according to an embodiment. The finger control gestures **400** include a touch **402**, a touch and hold **404**, a touch and move **406**, a flick **408**, a drag and drop **410**, and a pinch **412**. A touch **402** is a finger control gesture that executes the desired action once the user's finger is released from the screen. A touch and hold **404** is a finger control gesture that executes the desired action once the user has held his or her finger on the screen continuously for a predetermined duration (e.g., a few seconds), received a “hold completion” notification, and has released his or her finger from the screen. A touch and move **406** is a finger control gesture that manipulates and/or translates objects across the display **104** in the desired and permitted direction to a deliberate stopping point. To execute a touch and move finger control gesture **406**, the user touches an object, moves the object (left, right, up, down, diagonally, etc.), and releases the object. A flick **408** is a finger control gesture comprising contact of an object on the display **104** in conjunction with a quick finger movement in a particular direction, typically along a single vector. To execute a flick **408** finger control gesture the user touches an object on the display **104**, moves the object (typically, but not necessarily in a single direction) and releases the finger from the display **104** quickly, in a manner such that the contact point has a velocity throughout its path of motion. A drag and drop **410** is a finger control gesture by which the user moves an object to another location or to another object (e.g., a folder) and positions it there by releasing it. To execute a drag and drop **410** finger control gesture, the user touches, holds, drags and drops the object. A pinch **412** is a finger control gesture that expands or contracts the field of view on the display **104**. To execute a pinch **412** finger control gesture, the user touches the display **104** at two touch points using two fingers, for example, the thumb and index finger of a user's hand. Moving the touch points apart from each other zooms in on the field of view, enlarging it, while moving the touch points together zooms out on the field of view, contracting it.

[0062] In an embodiment the user interface includes multiple controls. For example, a toggle control enables a user to slide a knob to switch between toggle states. The toggle control also enables the user to press left or right of the toggle to quickly move the toggle left or right. If the toggle control is labeled, the user can press the label to quickly move the knob left or right.

[0063] The following paragraphs include a description of additional touch screen controls that can be used with the system of the present disclosure. The system can include any combination of the following controls and the present dis-

closure is not intended to be limited by the following descriptions of various controls.

[0064] In some embodiments, a spinner control enables the user to press a center (focused) tile to expand a spinner when the spinner is closed and to collapse a spinner when the spinner is opened. The spinner control enables the user to swipe up or down which, when the spinner is open, scrolls through spinner tiles. The spinner control enables the user to press an unfocused tile which then scrolls the tile into a center, focused position. And the spinner control enables the user to collapse an open spinner by pressing anywhere outside the spinner.

[0065] A slider control enables the user to move a knob by sliding the knob. The slider control also enables the user to quickly move the knob to a specific position by pressing anywhere along the slider path.

[0066] A slider spinner control combines the control capabilities of the spinner control and the slider control.

[0067] A button control enables a user to perform an action, as defined by the button description, by pressing the button.

[0068] An icon menu control enables the user to open a specified menu by pressing a tile. The icon menu control enables the user to scroll icons left or right by swiping left or right anywhere on the display. The icon menu control enables the user to quickly center a tile corresponding to an indicator icon by pressing an indicator button.

[0069] A window control enables the user to open a parameter or measurement window when no parameter or measurement alarm is present, by pressing the parameter or measurement. The window control enables the user to silence a parameter or measurement alarm when a parameter or measurement alarm is present, by pressing the parameter or measurement. The window control enables a parameter or measurement to be moved to a different location on the display 104 by using a drag and drop 410 finger control gesture.

[0070] A well control enables the user to open a parameter or measurement menu when no parameter or measurement alarm is present, by pressing the parameter or measurement. The well control enables the user to silence a parameter or measurement alarm when a parameter or measurement alarm is present, by pressing the parameter or measurement.

[0071] A live waveform control enables the user to separate waveforms by swiping down. The live waveform control enables the user to combine waveforms by swiping up.

[0072] A trend line control enables the user to zoom in by pinching in, zoom out by pinching out, change a time range by panning, and open a parameter or measurement trend menu by pressing the y-axis.

[0073] An alarm silence icon control enables the user to silence all alarms by pressing the alarm silence icon.

[0074] An audio pause icon control enables the user to pause audio for a predetermined period of time, by pressing the audio pause icon.

[0075] Other status bar icon controls enable the user to open the relevant menu, by pressing the relevant status bar icon.

[0076] A back arrow control enables the user to exit a menu or abandon any changes made, by pressing a back arrow icon.

[0077] A confirm-or-cancel control enables the user to confirm changes to settings by pressing an OK button. The

confirm-or-cancel control enables the user to cancel changes to settings by pressing a cancel button.

[0078] A home control enables the user to navigate to the main screen at any time by pressing a home button.

[0079] FIG. 5 illustrates an embodiment of a user interface 500 displayed on the display 104 of the hub 100. In an embodiment the display 104 comprises a color, modular, touchscreen integral to the hub 100. Positioned horizontally along the top of the display 104 is a top status line 501 that displays system status as well as that provide shortcuts to menu items or actions. In an embodiment the icons presented on the top status line 501 include alarm silence 501A, audio pause 501B, profiles 501C, Bluetooth 501D, Wi-Fi 501E, Ethernet 501F, connectivity gateway 501G, portable patient monitor battery status 501H, monitoring hub battery status 501I, sounds 501J, and current time 501K. The alarm silence icon 501A displays alarm status and mutes all audible alarms for monitoring devices connected to the hub 100. The audio pause icon 501B displays audio pause status and temporarily silences an alarm event. The profiles icon 501C provides access to a profiles screen; the example shown illustrates that the profile is set to "Adult" for an adult patient. The Bluetooth icon 501D provides access to a Bluetooth screen. If this icon is visible on the status line 501, then Bluetooth connectivity has been enabled. The Wi-Fi icon 501E provides access to a Wi-Fi screen. If this icon is visible on the status line 501, then Wi-Fi connectivity has been enabled. The icon itself also indicates the strength of the wireless signal. The Ethernet icon 501F provides access to an Ethernet screen. If this icon is visible on the status line 501, then Ethernet connectivity has been enabled. The connectivity gateway icon 501G provides access to a connectivity gateway screen. The example illustrated indicates that standalone devices are connected to three of the available four ports. The color of the icon matches the status colors of the connected standalone devices. The portable patient monitor battery status icon 501H displays the charging status of the portable patient monitor 102 and provides access to a portable patient monitor battery screen. The example illustrates that the battery is currently charging. The monitoring hub battery status icon 501I displays the charging status of the monitoring hub 100 and provides access to a monitoring hub battery screen. The example illustrates that the battery is currently charging. The sounds icon 501J provides access to a sounds screen to adjust alarm and pulse tone volume. In an embodiment the sounds icon 501J does not indicate the actual volume level of the alarm and the pulse tone. The current time icon 501K displays the current time and provides access to a localization screen which contains settings related to local time, language and geography.

[0080] Positioned horizontally along the bottom of the display 104 is a bottom status line 502 that displays additional icons and information including a main menu icon, a gender icon, and a patient identifier that includes patient-specific information, such as, for example, the patient's name and room location. Although the disclosed embodiment employs status lines 501, 502 oriented horizontally along the top and bottom of the display 104, one skilled in the art would readily appreciate that information of the type presented in the top status line 501 and in the bottom status line 502 may be presented in numerous different formats, combinations and configurations, including without limitation, one or more status bars positioned vertically on the

display 104. Moreover a skilled artisan will appreciate that other useful information may be displayed in status bars 501, 502.

[0081] In an embodiment the user interface creates a window for every monitoring device connected to the hub 100. Parameters or measurements can be expanded within a window to customize views. A central portion 504 of the display 104 presents patient measurement data, in this example, in two windows 506, 530. An upper window 506 presents patient data measured by a noninvasive monitoring platform—such as the rainbow® Pulse CO-Oximetry™ monitoring platform by Masimo Corporation of Irvine, Calif.—which enables the assessment of multiple blood constituents and physiologic parameters including oxygen saturation (SpO<sub>2</sub>) 508, pulse rate (PR) 510, respiration rate (RRp) 512, fractional arterial oxygen saturation (SpfO<sub>2</sub>) 514, total hemoglobin (SpHb) 516, plethysmograph variability index (PVI) 518, methemoglobin (SpMet) 520, carboxyhemoglobin (SpCO) 522, perfusion index (PI) 524, and oxygen content (SpOC) 526.

[0082] Advantageously, the display 104 is configurable to permit the user to adjust the manner by which the physiologic parameters are presented on the display 104. In particular, physiologic measurements of greater interest or importance to the clinician may be displayed in larger format and may also be displayed in both numerical and graphical formats to convey the current measurement as well as the historical trend of measurements for a period of time, such as, for example, the preceding hour. In an embodiment the oxygen saturation 508, pulse rate 510, and respiration rate 512 measurements are displayed in such a manner, taking up a larger portion of the upper portion 506 of the display 104, while the fractional arterial oxygen saturation 514, total hemoglobin 516, plethysmograph variability index 518, methemoglobin 520, carboxyhemoglobin 522, perfusion index 524, and oxygen content 526 measurements are displayed as numbers, taking up a smaller portion of the upper portion 506 of the display 104.

[0083] In an embodiment the presentation of measurement information may be adjusted easily by using the finger control gestures 400. For example, the touch and move 406 finger control gesture may be used to move an object on the display 104 representing a measurement from one location of the display 104 to another location of the display 104. Advantageously, when the object is moved, the display 104 automatically scales its presentation of information based upon the parameters that are active. For example, fewer parameters result in the presentation of larger digits, trend lines, and waveform cycles. In an embodiment the location to which an object is moved determines, at least in part, the manner by which that object will be presented on the display 104.

[0084] A lower window 530 of the display 104 presents patient data measured by a regional oximetry platform—such as the O<sub>3</sub>™ regional oximetry module by Masimo Corporation of Irvine, Calif.—which allows the continuous assessment of tissue oxygenation beneath one or more sensors placed on the patient's skin to help clinicians detect regional hypoxemia. Regional oximetry—also referred to as tissue oximetry and cerebral oximetry—enables the continuous assessment of the oxygenation of tissue beneath the sensor. Simultaneous measurement of both tissue oxygen saturation (rSO<sub>2</sub>) and arterial blood oxygenation (SpO<sub>2</sub>) provides clinicians, such as anesthesiologists or perfusion-

ists, a differential analysis of regional-to-central oxygen saturation monitoring, which helps the clinician to maintain brain oxygenation and safe cerebral perfusion during procedures.

[0085] In an embodiment the regional oximetry module is configured by applying one or more regional oximetry sensors to the patient, for example, the patient's forehead, and by connecting the module(s) to the hub 100. In an embodiment the regional oximetry module has as few as one and as many as four sensors. In an embodiment the regional oximetry module is connected to the hub 100 through the hub's 100 channel ports 212.

[0086] In an embodiment the regional oximetry platform uses near-infrared spectroscopy (NIRS) to continuously and simultaneously measure regional oxygen saturation (rSO<sub>2</sub>) and arterial oxygen saturation (SpO<sub>2</sub>), enabling the regional oximetry platform to automatically derive the differential analysis of a patient's regional-to-central oxygen saturation. In an embodiment the hub 100 derives the differential analysis of a patient's regional-to-central oxygenation saturation by comparing measurements provided to the hub 100 from two sources, such as a pulse oximetry measurement device and a regional oximetry measurement device.

[0087] FIGS. 6A-6B illustrate regional oximetry monitor user interface embodiments for designating adult and child sensor placement sites. As shown in FIG. 6A, an adult form 601 is generated on a user interface display. In an embodiment, between one and four sensor sites can be designated on the adult form 601, including left and right forehead 610, left and right forearm 620, left and right chest 630, left and right upper leg 640, left and right upper calf 650 and left and right calf 660 sites. Accordingly, between one and four sensors can be located on various combinations of these sites. The hub 100, which is in communication with these sensors, displays between one and four corresponding regional oximetry graphs and readouts, as described with respect to FIGS. 7 and 8, below. In other embodiments, any number of sensors and sensor sites can be used, including all of the sensor sites illustrated in FIG. 6A and/or other sensor sites as well.

[0088] As shown in FIG. 6B, a child form 602 is generated on a user interface display. In an embodiment between one and four sensor sites can be designated on the child form 602, including left and right forehead 610, left and right renal 670, and left and right abdomen 680 sites. Accordingly, between one and four sensors can be located on these sites. The hub 100, which is in communication with these sensors, displays between one and four corresponding regional oximetry graphs and readouts, as described in FIGS. 7 and 8 below. In other embodiments, any number of sensors and sensor sites can be used, including all of the sensor sites illustrated in FIG. 6B and/or other sensor sites as well.

[0089] FIG. 7 illustrates an embodiment of a regional oximetry window display 700 for monitoring parameters derived from one or more regional oximetry sensors. This particular example is a two-sensor display for monitoring, for example, a forehead left 710 site and a forehead right 730 site. In an upper portion of the display 700, the forehead left 710 site displays, for example, an SpO<sub>2</sub> graph 712, an rSO<sub>2</sub> graph 714 and an rSO<sub>2</sub> readout 716. Similarly, the forehead right 730 site displays, for example, an SpO<sub>2</sub> graph 732, an rSO<sub>2</sub> graph 734 and an rSO<sub>2</sub> readout 736. In other embodiments, any number of sensors and sensor sites can be used.

[0090] Also shown in FIG. 7, in a lower portion of the display 700, is a forehead left display well 750 that displays, for example, an SpO<sub>2</sub> readout 752, a ΔSpO<sub>2</sub> readout 754 and a Δbase readout 756. Similarly, the forehead right display well 730 displays, for example, an SpO<sub>2</sub> readout 772, a ΔSO<sub>2</sub> readout 774 and a Δbase readout 776.

[0091] FIG. 8 illustrates an embodiment of the user interface 800 in which a regional oximetry parameter display 104 accommodates four regional oximetry sensor inputs. In this example, a first two-sensor display 801 is enabled for monitoring a forehead left site 810, 830 and a forehead right site 820, 840. A second two-sensor display 802 is enabled for monitoring a chest left site 850, 870, and a chest right site 860, 880. Notably, a pulse oximetry parameter display 805 is allocated less display space than the regional oximetry parameter display 806 to accommodate the graphical area needed to display the regional oximetry parameter data. In an embodiment the display 800 automatically scales to allocate display space according to preferences set by the user. In other embodiments, any number of sensors and sensor sites can be used.

[0092] FIGS. 9A-9B generally illustrate embodiments for regional oximetry monitoring. As shown in FIG. 9A, a regional oximetry pod array 900 has a first pod assembly 910 and a second pod assembly 920. Each pod assembly 910, 920 communicates with an array of one or two regional oximetry sensors 960 via sensor cables 950. In other embodiments the pod assemblies 910, 920 can communicate with any number of regional oximetry sensors 960. The sensors 960 are attached to various patient locations, with one or two regional oximetry pods 930 and a corresponding number of pod cables 940 providing communications between the pods 930 and the hub 100. In other embodiments any number of sensors, positioned at any number of sensor sites on the patient's body can be used, and any number of pod assemblies can be used to connect the sensors to the hub 100. The pods 930 perform the physiological sensor signal processing normally associated with a monitoring device, which advantageously allows regional oximetry pods 930 to easily integrate with third party monitors 100 ranging from relatively "dumb" display devices that perform little or no signal processing to relatively "intelligent" multi-parameter patient monitors, which communicate with a variety of sensors and which perform sophisticated signal processing at the monitor level.

[0093] As shown in FIG. 9B, a regional oximetry pod assembly 911 embodiment has a pod 931 that communicates with up to two regional oximetry sensors 961 via sensor cables 951. In other embodiments the pod 931 can communicate with any number of regional oximetry sensors 961. In turn, the pod 931 communicates with an attached monitor hub 100 via a pod cable 941. In an embodiment the pod cable 941 connects to one of the channel ports 212 of the hub 100.

[0094] Embodiments of user interfaces for configuring a regional oximetry system to operate with a hub 100 follow.

[0095] When multiple regional oximetry sensors 960 are positioned on a patient's body and connected to the hub 100, there is a potential for confusion as to where each sensor is positioned on the patient. This potential for confusion is increased when, as in some embodiments, pod assemblies 920, 930 are used to connect multiple sensors 960 to the hub 100 because embodiments of pod assemblies 920, 930 can connect multiple sensors 960 to a single channel port 212 of

the hub 100. Inadvertent mislabeling of sensor location can lead to misreading of the physiological data being displayed, thereby posing a risk to the patient. Advantageously embodiments of the user interface for configuring a regional oximetry system to operate with a hub 100, disclosed herein, address this concern by displaying information describing the connectivity status and configuration of sensors 960, pod assemblies 920, 930 and channel ports 212. In some embodiments the information describing the connectivity status and configuration includes visual representations to assist clinicians in properly labeling and configuring the hub 100 to work appropriately with a regional oximetry system.

[0096] FIGS. 10A-10F illustrate embodiments of a user interface for selecting a first sensor site employing a menu-based, hierarchical navigation structure. FIG. 10A illustrates a main menu 1000A which is accessed by pressing a main menu icon 1000. The main menu presents several options for the user to select. The main menu options permit the user to navigate to various features of the user interface. Main menu options include, without limitation, device settings, information, trend settings, profiles, connectivity, layout, and sounds. As depicted in FIG. 10A, a regional oximetry device icon 1001 is selected using a touch 402 finger control gesture, which causes the display 104 to replace the main menu with a regional oximetry menu 1000B, illustrated in FIG. 10B. Selection of the sensor sites icon 1002 opens a sensor sites menu 1000C shown in FIG. 10C. As illustrated in FIG. 10C a connectivity window 1003 graphically displays the connectivity state of the channel ports 212 of the hub 100. In this illustrative example, pod 1 1004 is connected to port 1 1006, and sensor cable 1 1008 is connected to pod 1 1004. A sensor 1 button 1010 is illuminated to indicate that sensor 1 is connected. In contrast, a sensor 2 button 1012 is not illuminated (or grayed-out), indicating that no sensor cable is connected to it. An information line 1014 instructs the user to select a sensor 1 site. As illustrated, an adult form 1016 is generated to display potential sites of the patient's body where a regional oximetry sensor can be placed, including right and left forehead, right and left forearm, right and left chest, right and left upper leg, right and left upper calf, and right and left calf. With the touch finger control gesture 402 the user selects a sensor location on the adult form 1016 to identify where, on the patient, the regional oximetry sensor has been placed. As illustrated in FIG. 10C the left forehead sensor site 1018 is selected.

[0097] FIG. 10D illustrates a confirmation user interface display 1000D for selecting a first sensor site. The left forehead sensor site 1018 changes color, for example from white to blue, and the numeral "1" appears on the left forehead sensor site 1018, indicating that the sensor 1 site has been selected. Additionally the information line 1014 indicates that the sensor site has been selected by stating "SENSOR 1: FOREHEAD LEFT." The user is prompted to confirm the sensor site selection by touching an OK button 1020.

[0098] FIG. 10E illustrates an embodiment of a user interface in which the patient is a child 1000E. A child form 1022 is generated to display potential sites of the patient's body where a regional oximetry sensor can be placed, including right and left forehead, right and left renal and right and left abdomen. In this example, the left forehead sensor site 1018 changes color, for example from white to blue, and the numeral "1" appears on the left forehead sensor site 1018, indicating that the sensor 1 site has been selected.

Additionally the information line **1014** indicates that the sensor site has been selected by stating “SENSOR 1: FOREHEAD LEFT.” The user is prompted to confirm the sensor site selection by touching an “OK” button **1020**.

[**0099**] FIG. 10F illustrates an embodiment of a user interface display in which a sensor **1** is configured and monitoring the patient’s regional oximetry of the left forehead **1000F**. In this example, a two-sensor window **1030** is enabled for monitoring a forehead left site **1032**, **1034**. Configuration of additional pods, selection of additional sensor sites, and modification of sensor sites can be performed in a similar manner to that described with respect to FIGS. 10A-F.

[**0100**] FIGS. 11A-11D illustrate embodiments of a user interface for setting a baseline for a regional oximetry sensor. The baseline is a reading of the patient’s regional oximetry level before a patient is sedated. The baseline is compared with the patient’s sedated regional oximetry measurements to assess whether the patient is being adequately oxygenated during, for example, a procedure.

[**0101**] FIG. 11A illustrates an embodiment of a graphical display **1100A** in which two regional oximetry sensors are positioned on the patient, where sensor **1** is positioned on the left forehead and sensor **2** is positioned on the right forehead. To initiate the process of setting a baseline for, say, sensor **1**, the user selects a  $\Delta$ base icon **1102** using a touch finger gesture **402**. As illustrated in FIG. 11B, a sensor **1** delta baseline menu **1100B** appears. By selecting the set baseline icon **1103**, a set baseline display **1100C** appears as illustrated in FIG. 11C. A baseline action screen **1104** appears with an information line **1105** instructing the user to set a baseline for sensor **1**. The user enables the baseline feature for sensor **1** by sliding a toggle switch **1106** into the “on” position using, for example, a touch and move **406** finger control gesture. An arrow icon **1108** allows the user to navigate back to the previous screen if desired. Advantageously, while the user is engaged in configuring the hub **100** by engaging action screens, monitored data is displayed in the background with brightness reduced. FIG. 11D illustrates an updated set baseline display **1100D**. The action screen **1104** expands to include a baseline setting slider **1110** and a numerical display **1112**. As the user slides the baseline setting slider **1112** left or right, using for example the touch and move **406** finger control gesture, a corresponding numerical value is indicated on the numerical display **1112**. FIG. 11E illustrates an embodiment **1100E** in which the baseline is set by using a flick **408** finger control gesture on the numerical display **1112**. In this example the user confirms the sensor site selection by touching an “OK” button **1114**, and the action screen **1104** closes returning the user interface display **1100F** to its previous level of brightness, as illustrated in FIG. 11F. The  $\Delta$ base object **1102** now displays a numerical value, indicating that the baseline feature has been enabled and set. Setting baselines for additional sensor sites can be performed in a similar manner as to that described herein.

[**0102**] Referring back to FIG. 11B, by selecting the alarms icon **1107**, the user navigates to a menu to set sensor **1** delta baseline alarms **1100G**, illustrated in FIG. 11G. A delta baseline alarms action screen **1120** appears in which the user can set alarm conditions for the monitoring of sensor **1** delta baseline information. In an embodiment the alarm conditions include a delta limit **1122**, a delta caution range **1124**, and a silence duration **1126**. Advantageously the alarm

conditions can be used to graphically represent the status of the delta baseline metric on a trend view, as described below with respect to FIGS. 15A-B.

[**0103**] In an embodiment the hub **100** displays a differential analysis of a patient’s regional-to-central oxygen saturation, also referred to as  $\Delta$ SpO<sub>2</sub>, where measurement of the patient’s arterial oxygen saturation is compared with one or more measurements of regional oxygen saturation. The source of measurements of the patient’s arterial oxygen saturation used to determine the patient’s regional-to-central oxygen saturation can be provided by the regional oximetry sensor or by a peripheral arterial oxygen sensor. FIGS. 12A-12E illustrate embodiments of a user interface for setting a source for measuring arterial oxygen saturation for determining a patient’s regional-to-central oxygen saturation. FIG. 12A illustrates an embodiment of a user interface **1200A** in which two regional oximetry sensors are positioned on the patient, where sensor **1** is positioned on the left forehead and sensor **2** is positioned on the right forehead. To initiate the process of setting a delta SpO<sub>2</sub> source for, say, sensor **2**, the user selects a  $\Delta$ SpO<sub>2</sub> icon **1202** using a touch finger gesture **402**. As illustrated in FIG. 12B, a delta SpO<sub>2</sub> screen **1200B** appears with three delta SpO<sub>2</sub> menu icons on the display including a “set SpO<sub>2</sub> delta source” icon **1204**, an “alarms” icon **1206**, and an “about delta baseline” icon **1208**. When the user selects the “set SpO<sub>2</sub> delta source” icon **1204**, an SpO<sub>2</sub> delta source display **1200C** appears. A delta source action screen **1210** appears, as illustrated in FIG. 12C. The information line instructs the user to select an SpO<sub>2</sub> delta source for sensor **2**. The user selects the SpO<sub>2</sub> delta source for sensor **2**, in this case, by sliding a toggle switch icon **1212** either to the regional oximetry sensor location—which in this case is identified as forehead—or to a peripheral setting, using a touch and move **406** finger control gesture. As illustrated in FIG. 12D, once the SpO<sub>2</sub> delta source is selected (to forehead in this illustration) the user is prompted to confirm the delta source selection by touching an “OK” button **1214**. Alternatively, the user can cancel the delta source selection by touching a “cancel” button **1216**. The action screen **1210** then closes returning the main display **1200E** to its previous level of brightness, as illustrated in FIG. 12E, indicating that in this embodiment, the sensor **2** SpO<sub>2</sub> delta source is set.

[**0104**] Referring back to FIG. 12B, by selecting the alarms icon **1205**, the user navigates to a menu to set sensor **2** delta SpO<sub>2</sub> alarms **1200F**, illustrated in FIG. 12F. A delta baseline alarms action screen **1220** appears in which the user can set alarm conditions for the monitoring of sensor **2** delta baseline information, including a delta limit **1222**, a delta caution range **1224**, and a silence duration **1226**.

[**0105**] FIGS. 13A-13E illustrate embodiments of a user interface for setting parameters of a sensor used in a regional oximetry system to operate with the hub **100**. The user navigates from the main menu and the regional oximetry menu (described above with respect to FIGS. 10A-B) to arrive at, say, a sensor **1** menu **1300A**, as illustrated in FIG. 13A. By selecting a regional oxygen saturation icon **1302**, the user navigates to a menu for sensor **1** regional oxygen saturation (rSO<sub>2</sub>) settings **1300B** as illustrated in FIG. 13B. Similarly, by selecting an alarms icon **1308**, the user navigates to a screen for setting sensor **1** rSO<sub>2</sub> alarms **1300C** which displays an action screen **1314** for setting sensor **1** regional oxygen saturation (rSO<sub>2</sub>) alarms, as illustrated in FIG. 13C. In an embodiment the alarms include high limit,

low limit, high caution range, low caution range, and silence duration. The action screen **1314** features buttons to turn on or off various alarms and sliders by which the user can set parameters, such as limits, ranges and durations, to establish alarm triggering conditions for a given sensor positioned on a patient.

[**0106**] Referring back to the sensor menu of FIG. **13A**, the user can select the oxygen saturation icon **1304** to navigate to, for example, the sensor **1** oxygen saturation ( $\text{SpO}_2$ ) settings menu **1300D**, illustrated in FIG. **13D**. By selecting an alarms icon **1316**, the user navigates to a sensor **1**  $\text{SpO}_2$  alarms menu **1300E** displaying an action screen **1318** for setting sensor **1** oxygen saturation ( $\text{SpO}_2$ ) alarms, as illustrated in FIG. **13E**. In an embodiment the alarms include high limit, low limit, high caution range, low caution range, rapid desaturation, alarm delay and silence duration. The action screen **1318** features buttons to turn on or off various alarms, sliders by which the user can set parameters, such as limits, ranges and durations, to establish alarm triggering conditions for a given patient. Advantageously the alarm conditions can be used to graphically represent the status of the delta baseline metric on a trend view, as described below with respect to FIGS. **15A-B**.

[**0107**] FIG. **14** illustrates an embodiment of a monitor display **1400** in which regional oximetry baseline delta measurements are presented. In this embodiment a two-sensor display **1402** is configured to present monitored patient data from the patient's left forehead **1404**, **1406** and from the patient's right forehead **1408**, **1410**. A baseline view icon **1412** is selected which results in formatting the patient's measured data to be presented graphically, with a baseline that has been set by the user, at the trend displays **1404**, **1408**. In the present example illustrated in FIG. **14** the baseline is set to 82 for both sensor **1** (positioned on the patient's left forehead) and sensor **2** (positioned on the patient's right forehead). Accordingly the user readily sees differences between the measured regional oximetry and a baseline level. Additionally, the present difference between the measured regional oximetry and the baseline is displayed numerically at well displays **1406**, **1410** next to the  $\Delta$ base label.

[**0108**] FIG. **15A** illustrates an embodiment of a monitor display **1500A** in which, among other things, the patient's regional-to-central oxygenation saturation measurements, or  $\text{SpO}_2$  delta, are presented. In this embodiment a two-sensor window display **1502** is configured to present monitored patient data from the patient's left forehead **1504**, **1506** and from the patient's right forehead **1508**, **1510**. A trend view icon **1512** is selected which, in this example, results in formatting the patient's measured data to be presented graphically with two trend lines: a first line representing measured arterial oxygen saturation **1514** and a second line representing regional oxygen saturation **1516** thereby visually reflecting the difference between the two measurements. In an embodiment the first line **1514** is displayed in a first color, for example, white, and the second line **1516** is displayed in a second color, for example, blue. Accordingly the user readily sees differences between the measured arterial oxygen saturation and the measured regional oxygen saturation and is able to distinguish one measurement from the other. Additionally, the present difference between the measured arterial oxygen saturation and measured regional oxygen saturation is displayed numerically at well displays **1506**, **1510** next to the  $\Delta\text{SpO}_2$  label.

[**0109**] Advantageously the area **1528** between the first line representing measured arterial oxygen saturation **1514** and the second line representing regional oxygen saturation **1516** is shaded with varying colors to visually indicate the state of the metric, in this case, the patient's regional-to-central oxygenation saturation measurements, or  $\text{SpO}_2$  delta. In an embodiment the area **1528** is shaded with, for example, a green color when no alarm or caution range is met, a yellow color when a caution range is met, and a red color when an alarm limit is met or exceeded, thereby visually alerting the user to circumstances that might require attention or clinical action. As illustrated in FIG. **15A** a portion **1530** of the area **1528** between the first line representing measured arterial oxygen saturation **1514** and the second line representing regional oxygen saturation **1516** for sensor **1** is shaded to indicate that the regional oximetry measurement of the patient's left forehead entered into the caution range.

[**0110**] FIG. **15B** illustrates an embodiment of a monitor display **1500B** configured as the one in FIG. **15A**, however multiple alarms are triggered. These include an alarm that the patient's left forehead regional oxygen saturation is less than 50 percent **1520**, an alarm that the regional-to-central oxygen saturation measurements of the patient's left forehead region differ by 55 percentage points **1522**, and an alarm that the patient's left forehead regional oxygen saturation is 43 percentage points below the patient's baseline **1524**. In an embodiment the alarm conditions are highlighted visually with bold borders that are, for example, bright red in color. Additionally the alarm silence icon **1526** is illuminated in, for example, bright red. The alarm silence icon **1526** is an indicator as well as a functional button. It always indicates the presence (or lack of presence) of alarms, and it can be used to temporarily suspend audible alarms for a predetermined amount of time, known as the silence duration. When the alarm silence icon is illuminated red, it signals that there is currently at least one active alarm that has not been silenced.

[**0111**] As previously described the area **1528** between the first line representing measured arterial oxygen saturation **1514** and the second line representing regional oxygen saturation **1516** is shaded with varying colors to visually indicate the state of the metric, in this case, the patient's regional-to-central oxygenation saturation measurements, or  $\text{SpO}_2$  delta. As illustrated in FIG. **15B** a portion **1532** of the area **1528** between the first line representing measured arterial oxygen saturation **1514** and the second line representing regional oxygen saturation **1516** for sensor **1** is shaded to indicate that the regional oximetry measurement of the patient's left forehead entered into the caution range and into the alarm limit range. For easy reference, a dotted line **1534** indicates the alarm limit as set by the user.

[**0112**] A regional oximetry user interface has been disclosed in detail in connection with various embodiments. These embodiments are disclosed by way of examples only and not to limit the scope of the claims that follow. One of ordinary skill in the art will appreciate from the disclosure herein any variations and modifications.

[**0113**] The term "and/or" herein has its broadest least limiting meaning which is the disclosure includes A alone, B alone, both A and B together, or A or B alternatively, but does not require both A and B or require one of A or one of

B. As used herein, the phrase “at least one of” A, B, “and” C should be construed to mean a logical A or B or C, using a non-exclusive logical or.

**[0114]** As used herein, the term module may refer to, be part of, or include an Application Specific Integrated Circuit (ASIC); an electronic circuit; a combinational logic circuit; a field programmable gate array (FPGA); a processor (shared, dedicated, or group) that executes code; other suitable components that provide the described functionality; or a combination of some or all of the above, such as in a system-on-chip. The term module may include memory (shared, dedicated, or group) that stores code executed by the processor.

**[0115]** The apparatuses and methods described herein may be implemented by one or more computer programs executed by one or more processors. The computer programs include processor-executable instructions that are stored on a non-transitory tangible computer readable medium. The computer programs may also include stored data. Non-limiting examples of the non-transitory tangible computer readable medium are nonvolatile memory, magnetic storage, and optical storage.

**[0116]** Although the foregoing has been described in terms of certain preferred embodiments, other embodiments will be apparent to those of ordinary skill in the art from the disclosure herein. Additionally, other combinations, omissions, substitutions and modifications will be apparent to the skilled artisan in view of the disclosure herein. Accordingly, the present invention is not intended to be limited by the description of the preferred embodiments, but is to be defined by reference to the claims.

**[0117]** Additionally, all publications, patents, and patent applications mentioned in this specification are herein incorporated by reference to the same extent as if each individual publication, patent, or patent application was specifically and individually indicated to be incorporated by reference.

**1-14.** (canceled)

**15.** A regional oximetry system comprising:  
a display; and

at least one processor, the processor causing a plurality of views to be displayed on the display, each view configured to occupy at least a portion of the display, each of the views adapted to present data responsive to at least one physiological signal;

a sensor port configured to receive a physiological signal representative of a regional tissue oxygenation level; the processor configured to set a baseline level representative of an acceptable state of the regional tissue oxygenation;

wherein one of the views presents a differential analysis of the regional tissue oxygenation level and the baseline level.

**16.** The regional oximetry system according to claim **15** wherein the view presents a numerical representation of the differential analysis of the regional tissue oxygenation level and the baseline level as presently measured.

**17.** The regional oximetry system according to claim **15** wherein the view presents a graphical representation of the differential analysis of the regional tissue oxygenation level and the baseline level.

**18.** The regional oximetry system according to claim **15** further comprising a first view that presents a numerical representation of the differential analysis of the regional tissue oxygenation level and the baseline level, and a second view that presents a graphical representation of the differential analysis of the regional tissue oxygenation level and the baseline level.

**19.** The regional oximetry system according to claim **17** wherein the graphical representation of the differential analysis of the regional tissue oxygenation level and the baseline level includes trend information.

**20.** The regional oximetry system according to claim **15** further comprising:

a set baseline menu view configured to occupy at least a portion of the display and adapted to present baseline display configuration information and baseline display configuration selections, the baseline menu comprising:

an enable toggle;

a baseline slider; and

a baseline spinner;

wherein the baseline slider and the baseline spinner are adapted to enable manual setting of the baseline level.

**21.** A regional oximetry system comprising:

a display;

a sensor port adapted to communicate with at least one sensor; and

at least one processor, the processor causing a plurality of views to be displayed on the display, each view configured to occupy at least a portion of the display;

wherein a set sensor menu view is configured to occupy at least a portion of the display and adapted to present a connectivity status of the sensor port and the at least one sensor.

**22.** The regional oximetry system according to claim **21** further comprising:

a pod array adapted to communicate with the at least one sensor and with the sensor port;

wherein the set sensor menu view presents a connectivity status of the pod array with the connectivity status of the sensor port and the at least one sensor.

**23.** The regional oximetry system according to claim **22** wherein the pod array is adapted to communicate with a plurality of sensors.

**24.** The regional oximetry system according to claim **22** wherein the set sensor menu view displays a graphical representation of the connectivity status of the sensor port, the pod array, and the at least one sensor.

**25.** The regional oximetry system of claim **20** wherein the set sensor menu view presents a human form to display potential sites of a patient's body where a sensor can be placed.

\* \* \* \* \*

专利名称(译)	区域血氧测定用户界面		
公开(公告)号	<a href="#">US20190029578A1</a>	公开(公告)日	2019-01-31
申请号	US16/025532	申请日	2018-07-02
[标]申请(专利权)人(译)	梅西莫股份有限公司		
申请(专利权)人(译)	Masimo公司		
当前申请(专利权)人(译)	Masimo公司		
[标]发明人	AL ALI AMMAR INDORF KEITH WARD KASHIF FAISAL		
发明人	AL-ALI, AMMAR INDORF, KEITH WARD KASHIF, FAISAL		
IPC分类号	A61B5/145 A61B5/00 A61B5/1455 H01R13/52		
CPC分类号	A61B5/6833 H01R13/5224 A61B5/14542 A61B5/742 A61B2562/225 A61B2562/22 A61B5/7275 A61B5/1455 A61B5/746 A61B2562/228 H01R2201/12 A61B2562/227 A61B5/14553 A61B5/14557 A61B2562/222 A61B5/14551 A61B5/14552		
优先权	62/012170 2014-06-13 US 61/887878 2013-10-07 US 61/887856 2013-10-07 US 61/887883 2013-10-07 US		
外部链接	<a href="#">Espacenet</a> <a href="#">USPTO</a>		

摘要(译)

区域血氧测定系统具有显示器和至少一个处理器，使得多个视图显示在显示器上，每个视图被配置为占据显示器的至少一部分。视图适于响应于至少一个生理信号呈现数据。第一传感器端口被配置为接收表示区域组织氧合水平的至少第一生理信号，并且第二传感器端口被配置为接收表示动脉氧饱和度水平的至少第二生理信号。一个视图呈现第一生理信号的第一趋势图和第二生理信号的第二趋势图。第一趋势图和第二趋势图之间的区域可以包括区域到中心氧饱和度的差异分析。

