



(19) **United States**

(12) **Patent Application Publication**  
**Goldminz et al.**

(10) **Pub. No.: US 2018/0256063 A1**

(43) **Pub. Date: Sep. 13, 2018**

(54) **CONFIGURABLE MULTI-CHANNEL ECG AND EEG MONITOR**

*A61B 5/042* (2006.01)

*A61B 5/0476* (2006.01)

*A61B 5/00* (2006.01)

(71) Applicants: **Lavy Goldminz**, Haifa (IL); **Moshe Chen**, Haifa (IL); **Yoav Shoham**, Haifa (IL)

(52) **U.S. Cl.**  
CPC ..... *A61B 5/04288* (2013.01); *A61B 5/04004* (2013.01); *A61B 5/0006* (2013.01); *A61B 5/0476* (2013.01); *A61B 5/7225* (2013.01); *A61B 5/0422* (2013.01)

(72) Inventors: **Lavy Goldminz**, Haifa (IL); **Moshe Chen**, Haifa (IL); **Yoav Shoham**, Haifa (IL)

(21) Appl. No.: **15/757,376**

(57) **ABSTRACT**

(22) PCT Filed: **Sep. 4, 2016**

(86) PCT No.: **PCT/IL2016/050973**

§ 371 (c)(1),

(2) Date: **Mar. 5, 2018**

**Related U.S. Application Data**

(60) Provisional application No. 62/214,988, filed on Sep. 6, 2015.

A monitor that includes multiple detection channels having multiple input ports for receiving a group of electrical physiological signals from a person; wherein multiple switching circuits of the monitor are configured according to a first configuration when the monitor operates in a first mode, thereby causing each electrical physiological signal of the group to be processed by up to a single selected detection channel of the multiple detection channels; wherein the multiple switching circuits of the monitor are configured according to a second configuration when the monitor operates in a second mode thereby causing one or more of the multiple electrical physiological signals of the group to be processed by at least two selected detection channels of the multiple detection channels.

**Publication Classification**

(51) **Int. Cl.**  
*A61B 5/0428* (2006.01)  
*A61B 5/04* (2006.01)

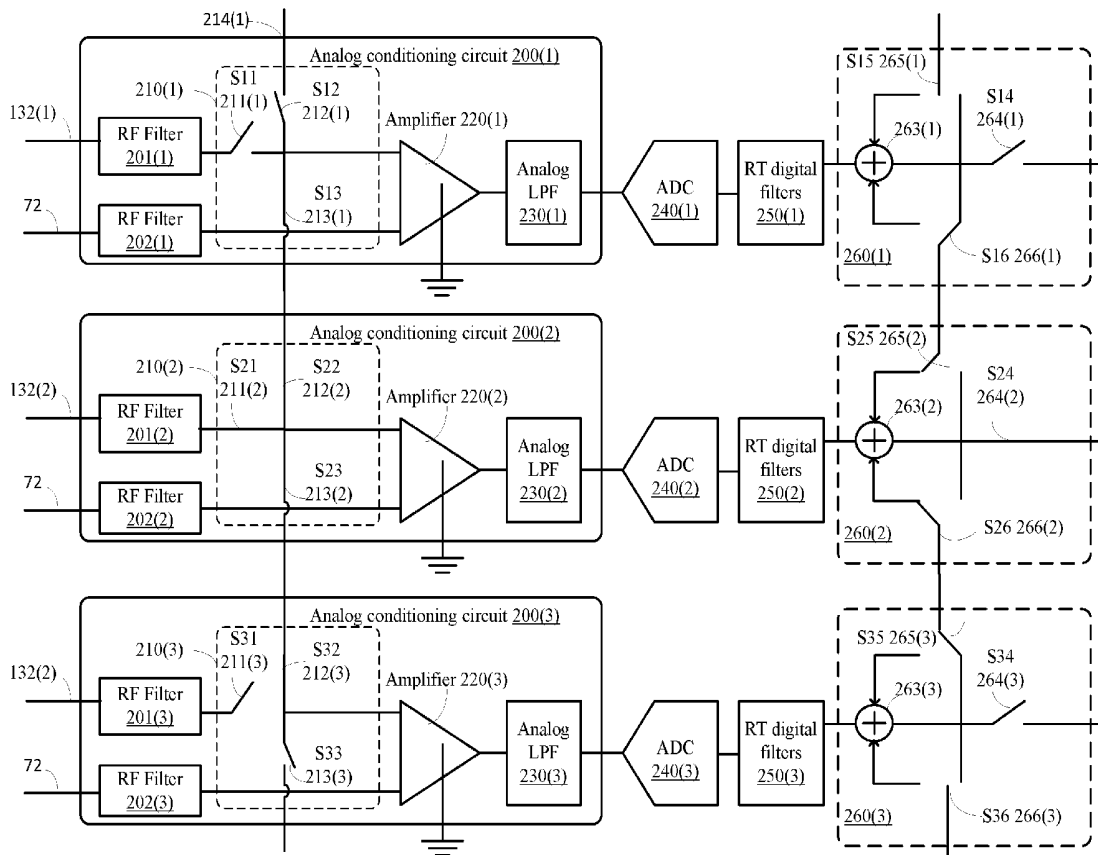

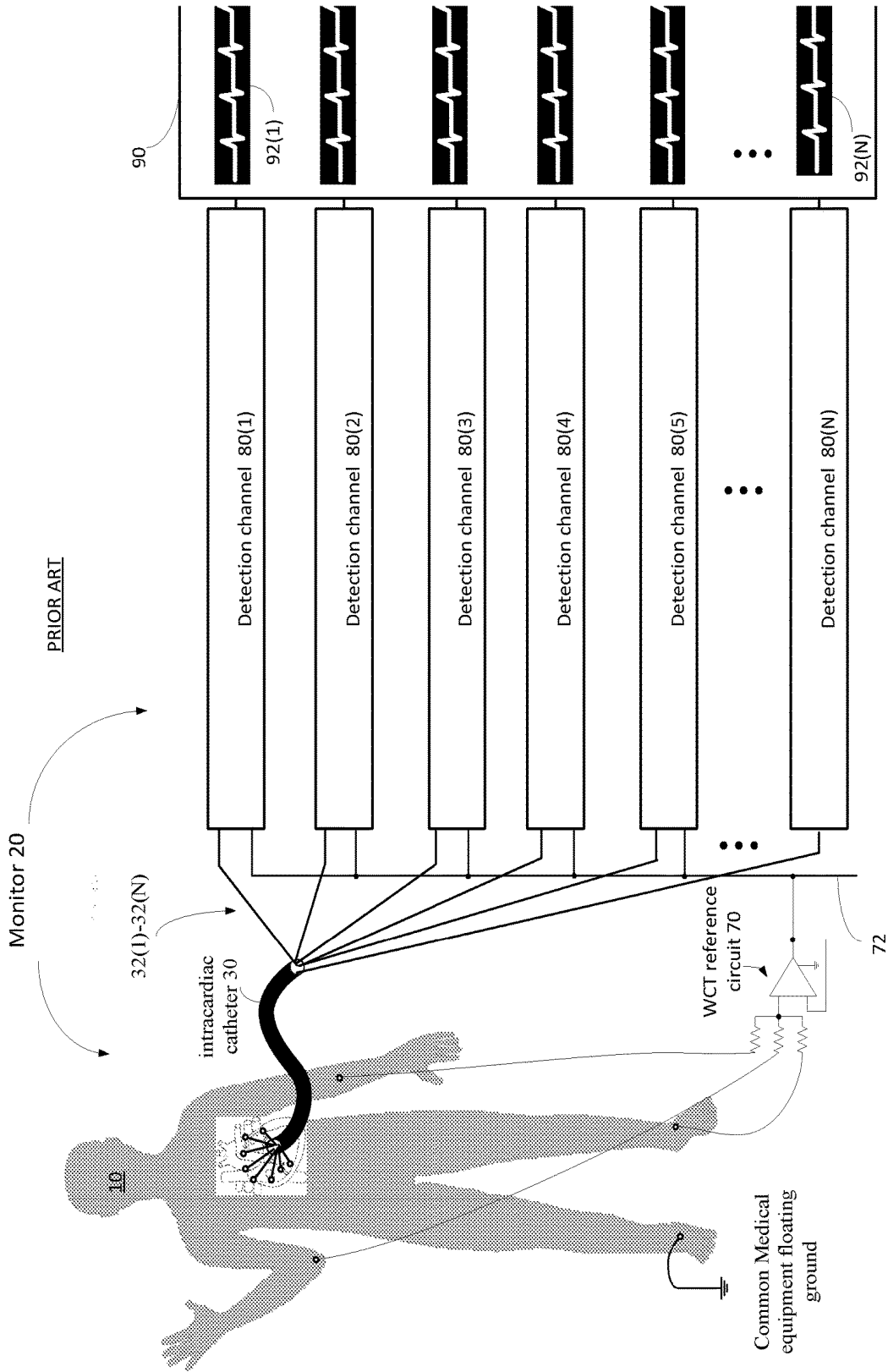

FIG. 1

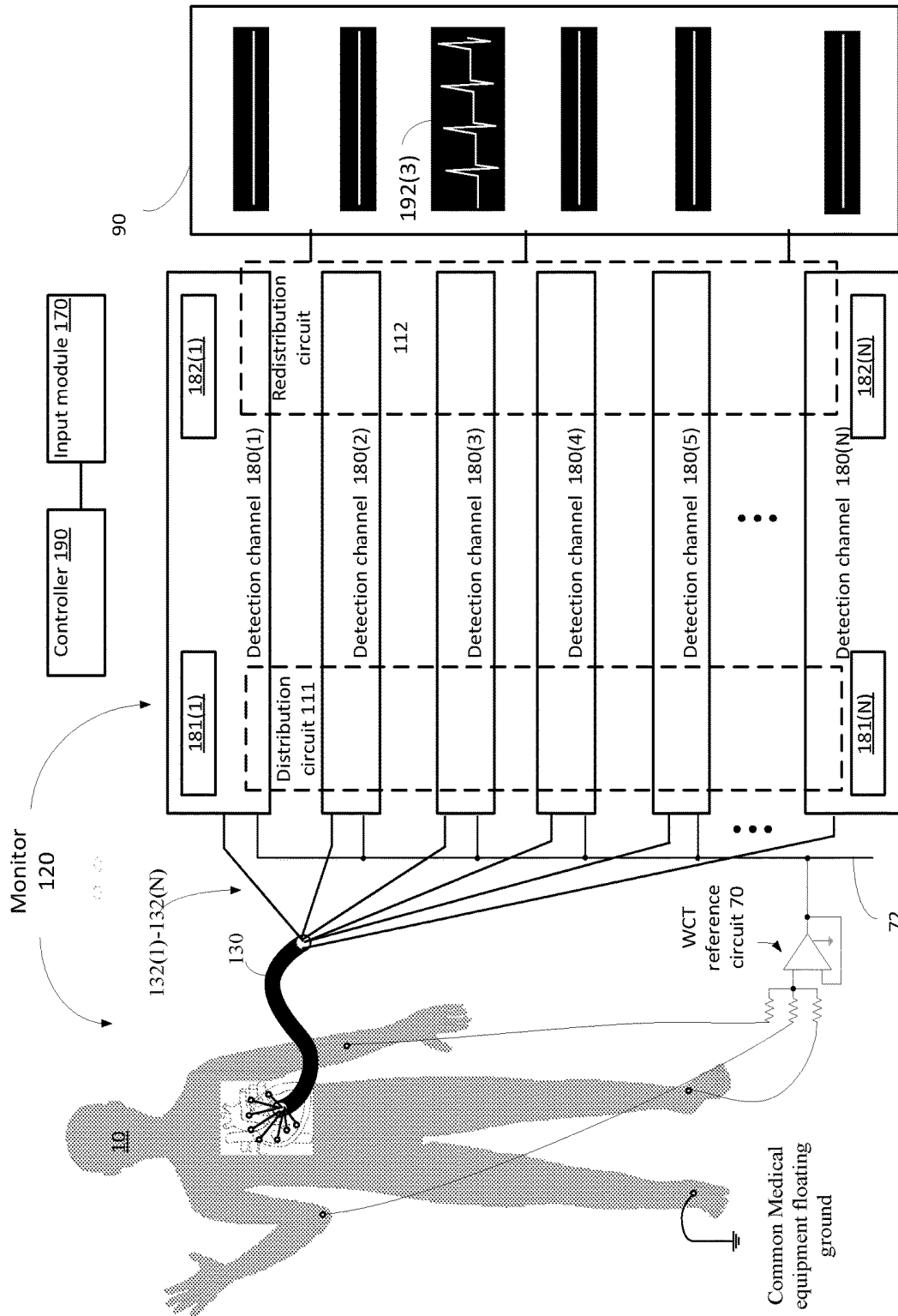

FIG. 2

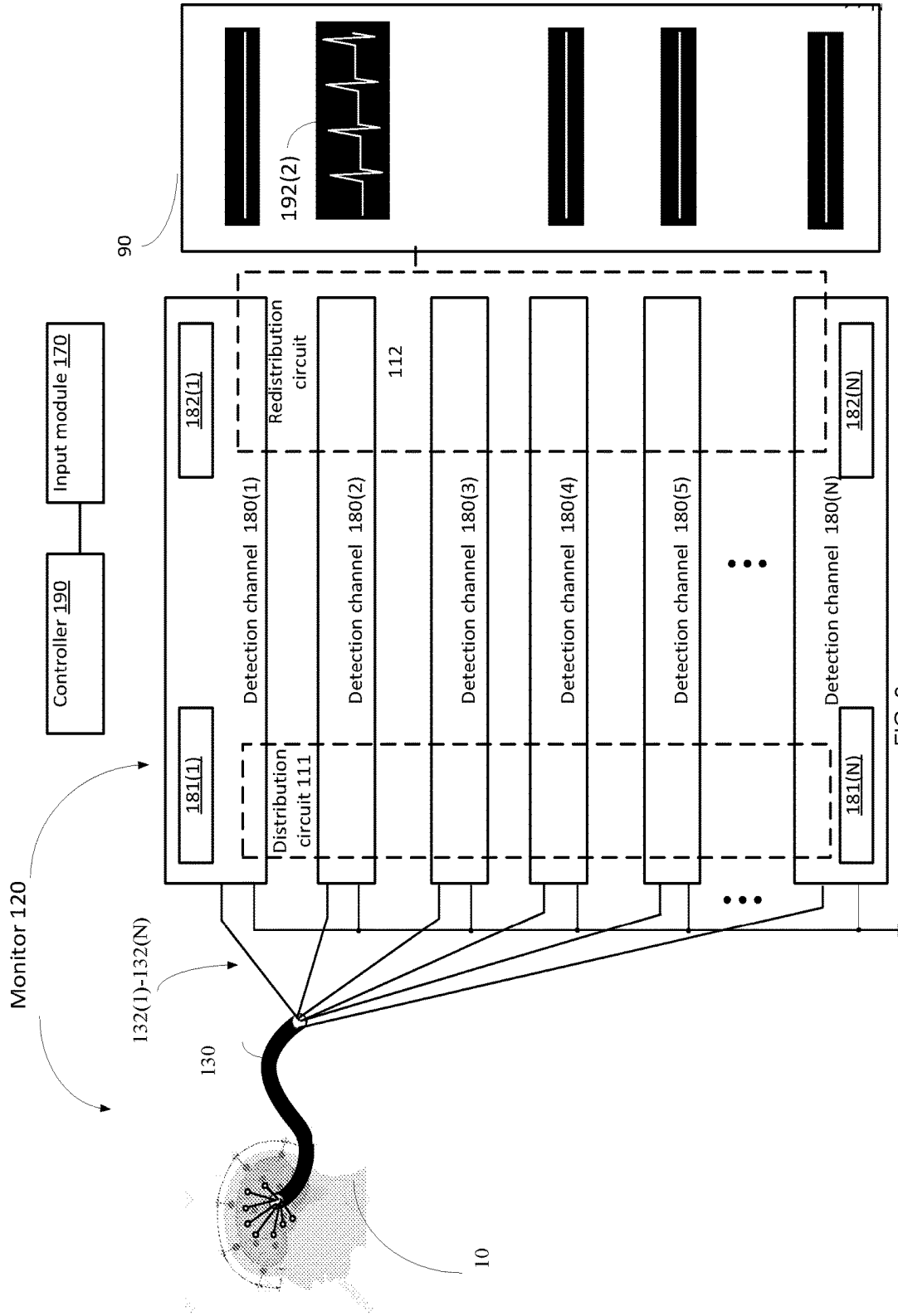

FIG. 3

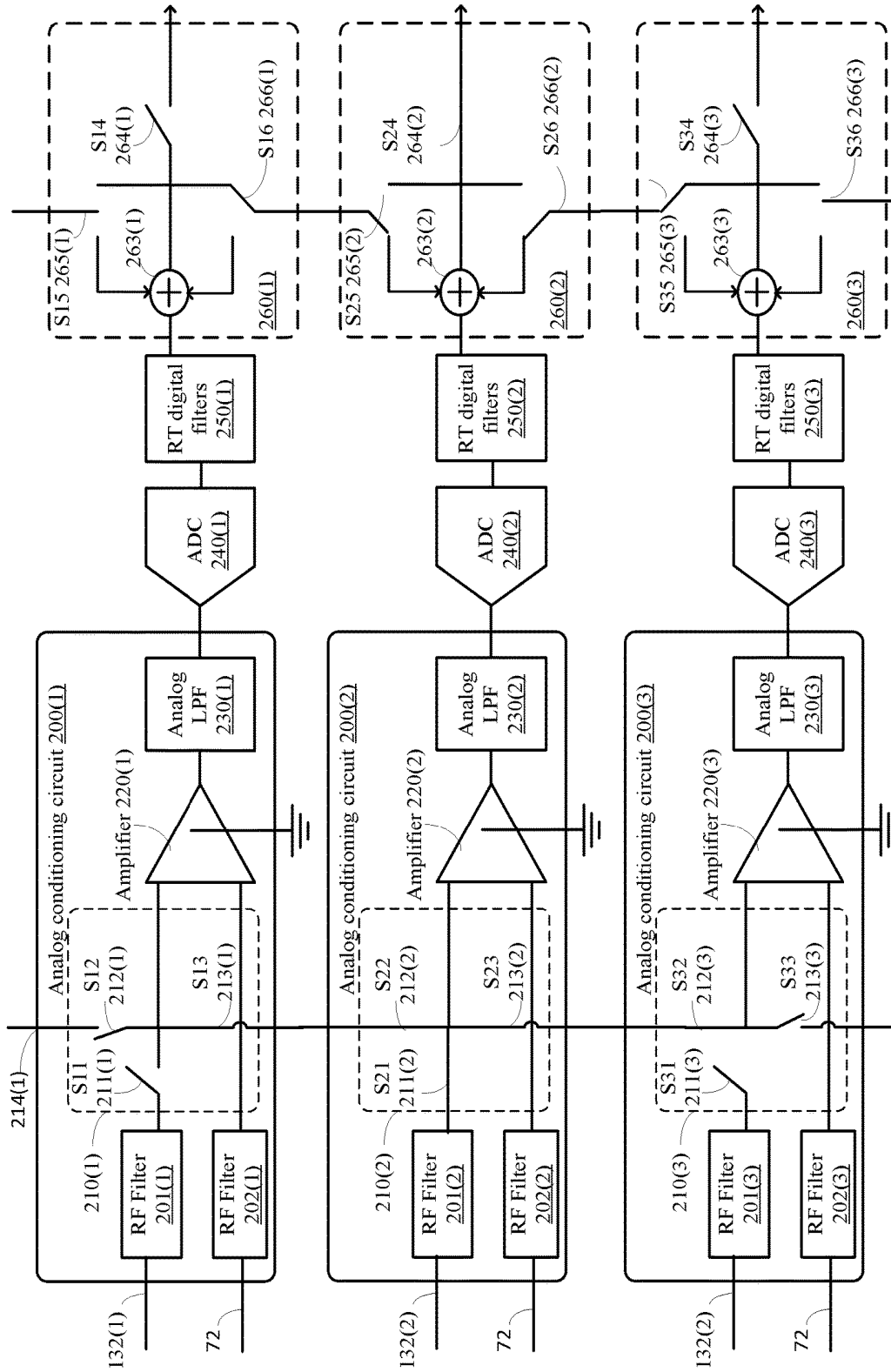
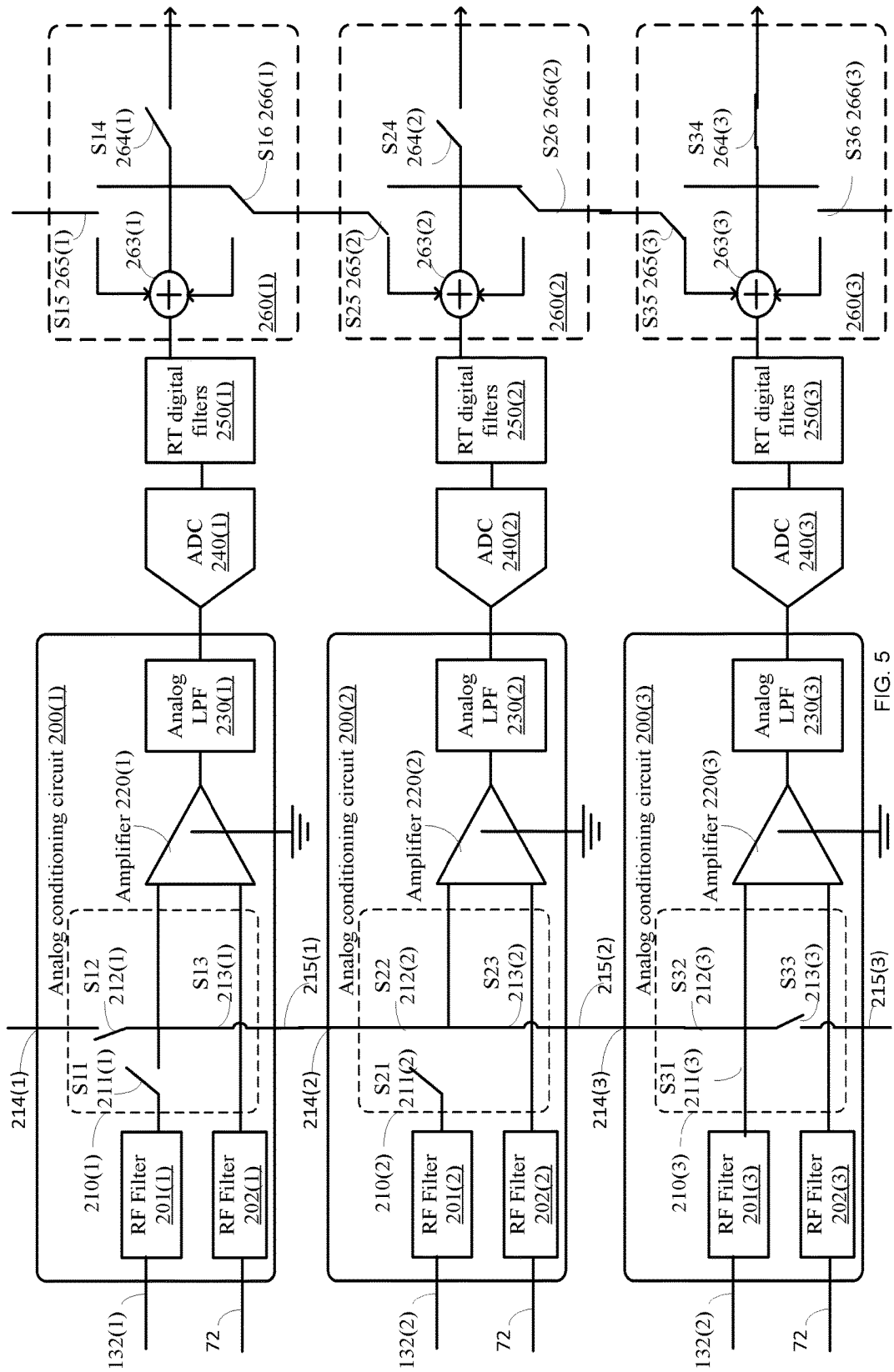

FIG. 4



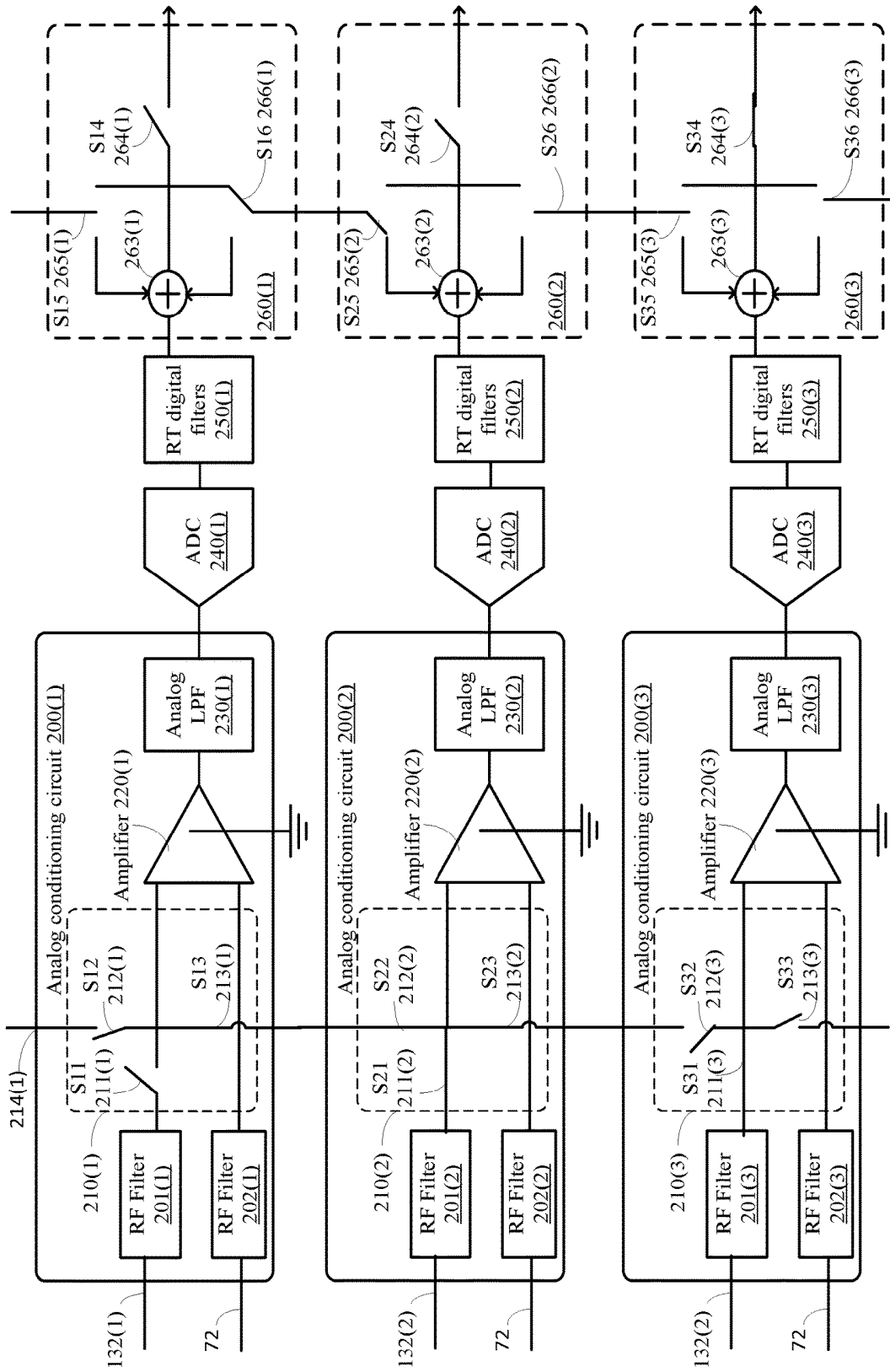

FIG. 6

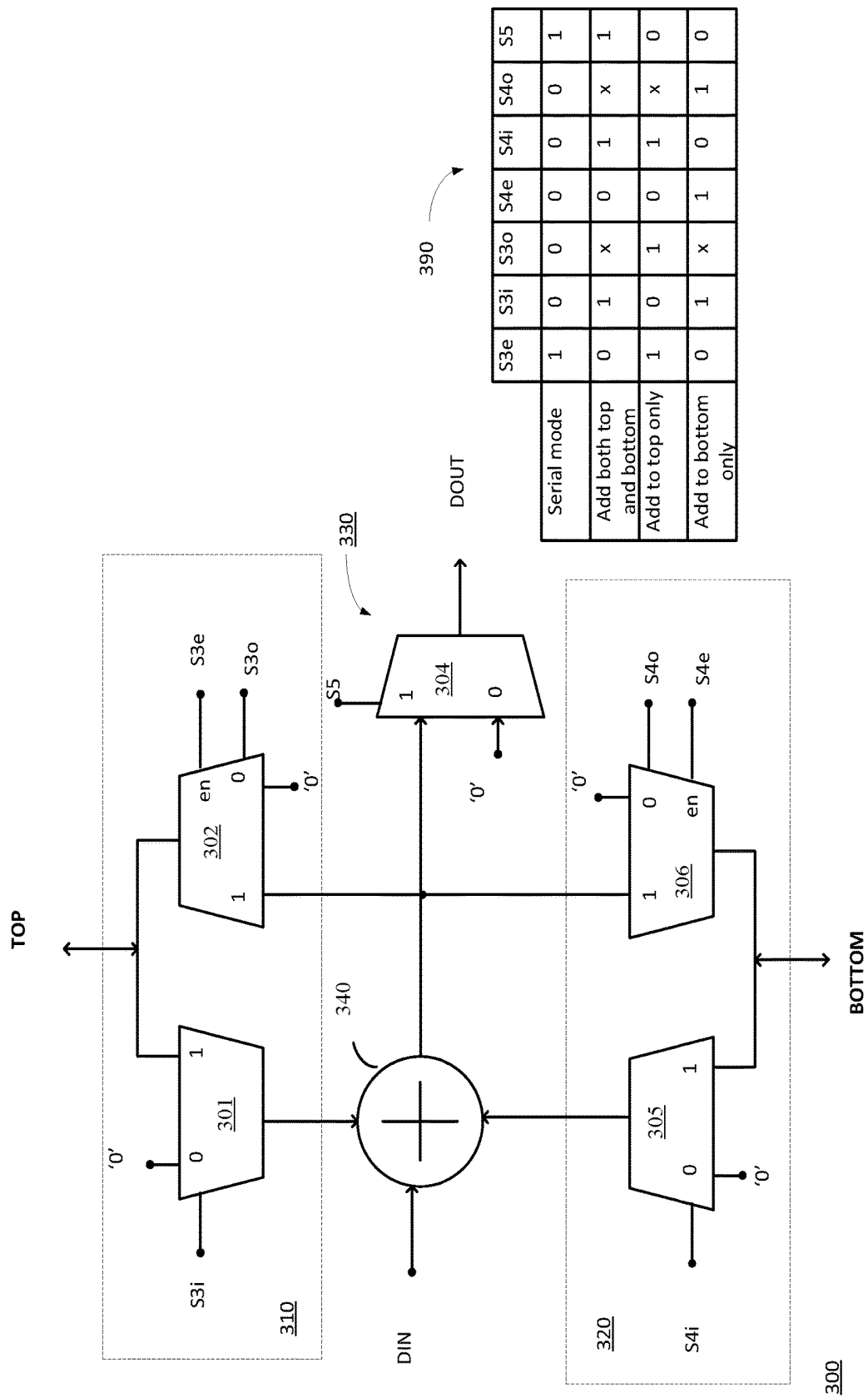

FIG. 7



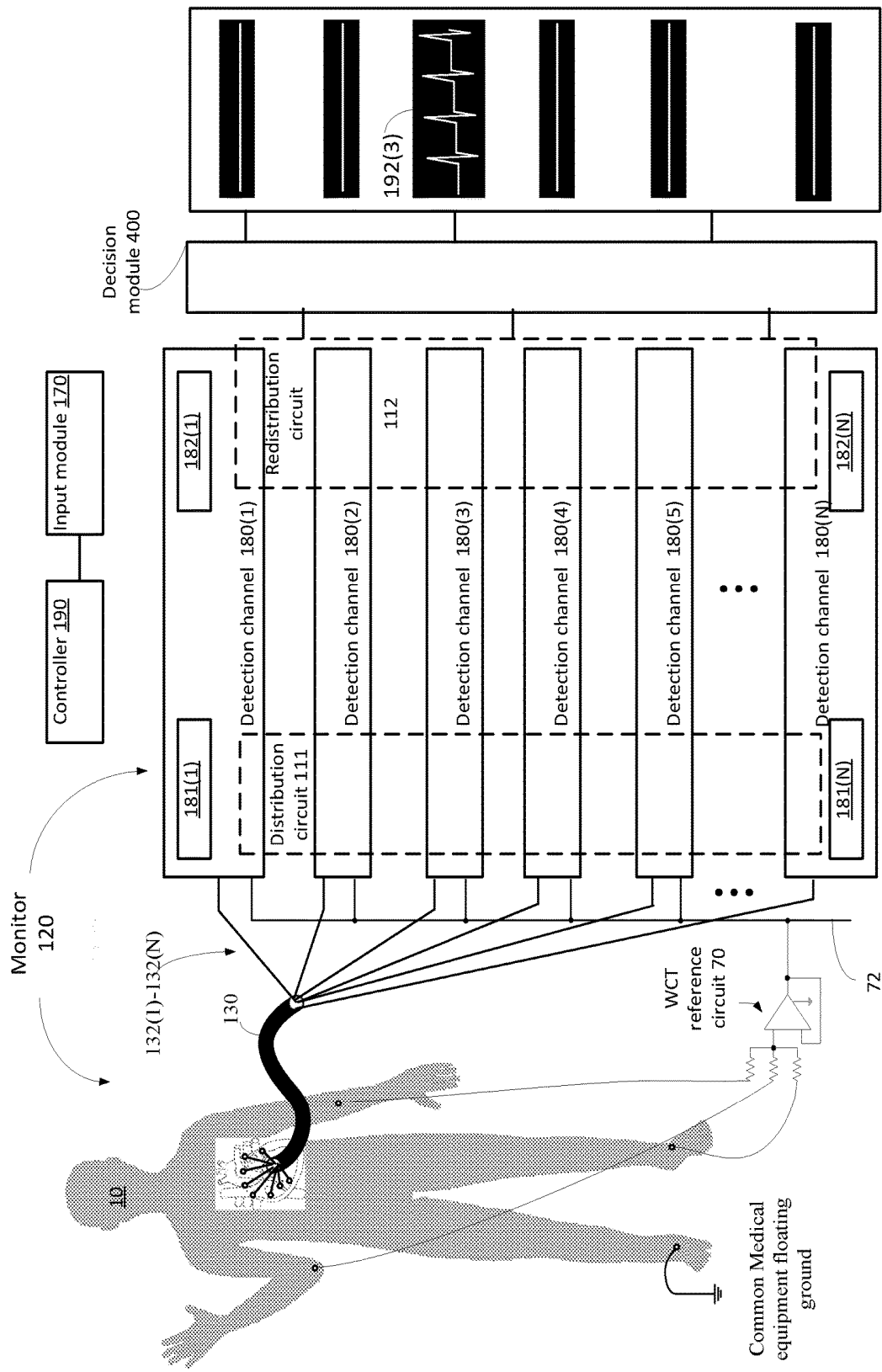

FIG. 8

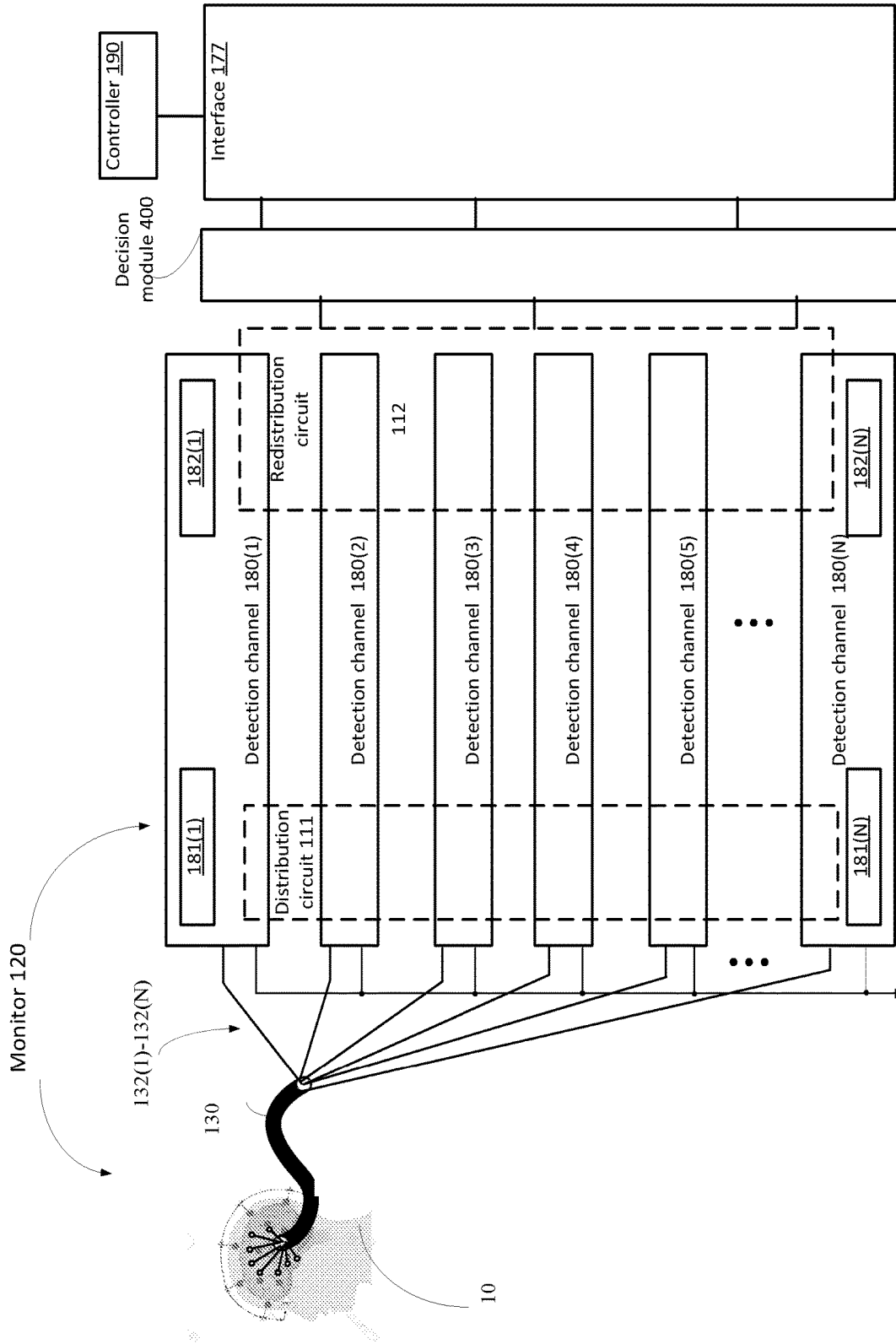

FIG. 9

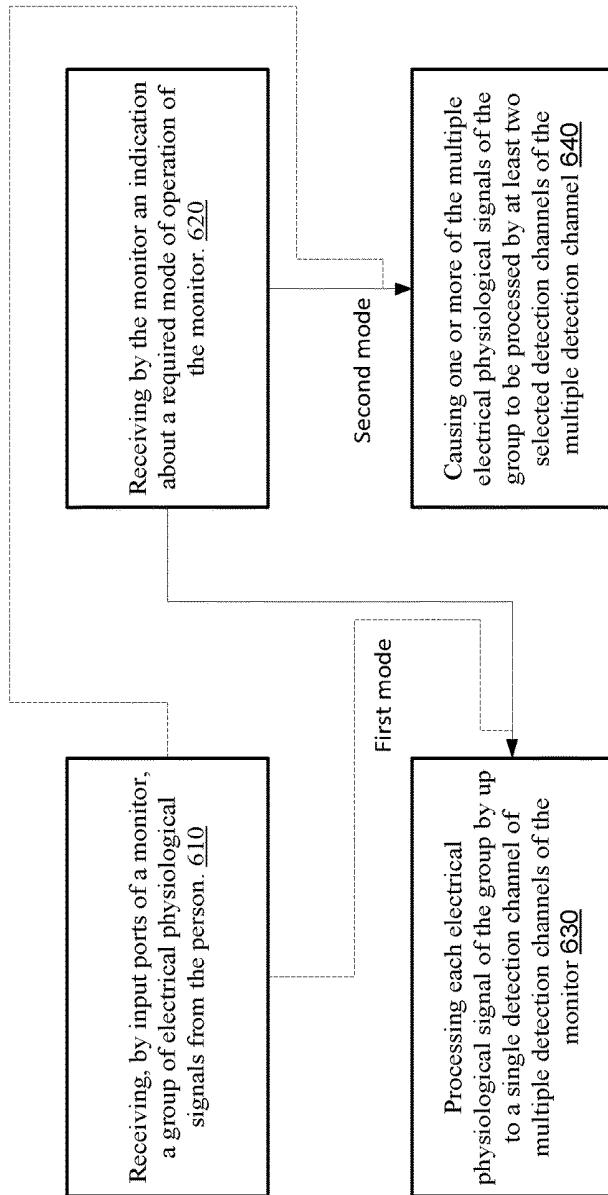

FIG. 10

## CONFIGURABLE MULTI-CHANNEL ECG AND EEG MONITOR

### BACKGROUND OF THE INVENTION

**[0001]** Various monitoring procedures such as electroencephalogram (EEG) and electrocardiogram (ECG) monitoring procedures are implemented using monitors that include increasing numbers of detection channel.

**[0002]** A monitor may include multiple electrodes.

**[0003]** The number of catheter electrodes in intra-cardiac ECG monitors and in Wearable EEG monitors is constantly increasing.

**[0004]** Each catheter electrode is connected to a different detection channel. Each detection channel may process only a single electrical physiological signal.

**[0005]** FIG. 1 illustrates a prior art monitor **20** that monitors a person **10**. The monitor **20** includes an intracardiac catheter **30** that includes multiple (N) conductors **32(1)-32(N)**. Each conductor electrically connected to an electrode and each receives a single ECG signal.

**[0006]** Each detection channel of the N detection channels **80(1)-80(N)** of monitor **20** may receive up to a single ECG signal (and a reference WCT signal generated by WCT reference circuit **70**) and process only up to a single ECG signal.

**[0007]** A display **90** displays multiple (N) ECG waveforms **92(1)-92(N)**—one per each ECG signal.

**[0008]** Each detection channel has its own analog signal conditioning circuit. Each analog conditioning channel amplifies and filters the signals received by the catheter tip.

**[0009]** In modern monitors the output of the analog signal conditioning circuit is converted to digital signals (also referred to as intermediate digital signals) by analog to digital converters (ADC) for further digital signal processing.

**[0010]** The increasing number of electrodes is used to obtain higher resolution and a more detailed electric activity map of an organ of the person. As a result a more complex multi-channel electronic (Analog and Digital) and software is required.

**[0011]** In an environment of a large number of electrodes a fine detailed ECG (or EEG) line originated from a specific electrode is required to help the user to reach more accurate medical decisions.

**[0012]** Noise generated by detection channels (for example—noise introduced by the signal conditioning circuits and/or the ADC) is the main obstacle to obtain a clear ECG (or EEG) picture.

**[0013]** The intra-cardiac ECG system (as in Wearable EEG system) must enable the user to focus on each of the many detection channels and to extract a high quality signal from the selected detection channel.

**[0014]** Each detection channel connected to each electrode must be realized by low noise circuitry.

**[0015]** Building a low noise multi-channel device in which each detection channel is good enough to view the fine details needed is expensive and power inefficient.

### SUMMARY OF THE INVENTION

**[0016]** According to an embodiment of the invention there may be provided a monitor that may include multiple detection channels having multiple input ports for receiving a group of electrical physiological signals from a person;

wherein multiple switching circuits of the monitor may be configured according to a first configuration when the monitor operates in a first mode, thereby causing each electrical physiological signal of the group to be processed by up to a single selected detection channel of the multiple detection channels; wherein the multiple switching circuits of the monitor may be configured according to a second configuration when the monitor operates in a second mode thereby causing one or more of the multiple electrical physiological signals of the group to be processed by at least two selected detection channels of the multiple detection channels.

**[0017]** The multiple switching circuits may be coupled to multiple analog signal conditioning circuits of the multiple detection channels.

**[0018]** The multiple switching circuits belong to multiple analog signal conditioning circuits of the multiple detection channels.

**[0019]** The switching circuits that belong to different detection channels may be configured to output different electrical physiological signals when the monitor operates in the first mode; and wherein a plurality of switching circuits that belong to a plurality of different selected detection channels may be configured to output a same electrical physiological signal when the monitor operates in the second mode.

**[0020]** The at least two switching circuits may belong to neighboring detection channels.

**[0021]** The at least two switching circuits may belong to more than two detection channels.

**[0022]** The each switching circuit may include three or more inputs for receiving three or more electrical physiological signals of the group.

**[0023]** The each switching circuit is positioned between different analog components of the analog conditioning circuit.

**[0024]** The each switching circuit is a first analog component of the analog conditioning circuit.

**[0025]** The each switching circuit is a last analog component of the analog conditioning circuit.

**[0026]** The each switching circuit is followed by an analog amplifier of the analog conditioning circuit; wherein the analog amplifier is also fed by a reference signal.

**[0027]** The multiple detection channels comprise multiple analog conditioning circuits that may be followed by multiple analog to digital converters for converting multiple analog output signals of the multiple analog conditioning circuits to multiple intermediate digital signals; wherein the multiple analog to digital converters may be followed by a digital manipulator; wherein the digital manipulator is prevented from adding intermediate digital signals from analog conditioning circuits of different selected detection channels when the monitor operates in a first mode; wherein the digital manipulator may be configured to add intermediate digital signals from analog conditioning circuits of the at least two selected detection channels when the monitor operates in the second mode.

**[0028]** The digital manipulator may include a digital manipulation circuit per each detection channel; wherein each digital manipulation circuit is coupled to a set of digital to analog converters of a set of detection channels.

**[0029]** The a digital manipulation circuit of a given detection channel that belongs to a given set of detection channels may include: a plurality of IO interfaces, each IO interface is coupled to a digital manipulation circuit of another

detection channel of the given set; an adder that has (a) a first input that is coupled to the analog to digital circuit of the given detection channel, (b) an IO interface for each other detection channel of the set, wherein each IO interface is coupled to a digital manipulation circuit of another detection channel of the set, and (c) an adder output; an output circuit for outputting a digital manipulation circuit output signal; wherein the output circuit is coupled to the adder output and to each one of the plurality of IO interfaces.

**[0030]** The digital manipulator is followed by a decision module for making decisions based upon output signals of the detection channels. The decision module may be a hardware processor or may hosted or executed by the hardware processor, may be a part of a gaming device, of a wearable device, and the like.

**[0031]** The monitor further may include a display for displaying multiple output signals of the multiple detection channels.

**[0032]** The display may be configured to display an aggregate signal that represents an outcome of the processing each one of the one or more of the multiple electrical physiological signals by the at least two selected detection channels of the multiple detection channels.

**[0033]** The group of physiological signals may be electrocardiogram (ECG) signals.

**[0034]** The group of physiological signals may be electroencephalogram (EEG) signals.

**[0035]** The monitor may include a controller that may be configured to determine an operational mode of the monitor.

**[0036]** According to an embodiment of the invention there may be provided a method for monitoring a person, the method may include receiving, by input ports of a monitor, a group of electrical physiological signals from a person; configuring multiple switching circuits of the monitor according to a first configuration when the monitor operates in a first mode, thereby causing each electrical physiological signal of the group to be processed by up to a single selected detection channel of multiple detection channels of the monitor; configuring multiple switching circuit of the monitor according to a second configuration when the monitor operates in a second mode, thereby causing one or more of the multiple electrical physiological signals of the group to be processed by at least two selected detection channels of the multiple detection channels.

**[0037]** According to an embodiment of the invention there may be provided a non-transitory computer readable medium that may store instructions that once executed by a monitor cause the monitor to: configure multiple switching circuits of the monitor according to a first configuration when the monitor operates in a first mode, thereby causing each electrical physiological signal of a group of electrical physiological signals received from a person to be processed by up to a single selected detection channel of multiple detection channels of the monitor; configuring multiple switching circuit of the monitor according to a second configuration when the monitor operates in a second mode, thereby causing one or more of the multiple electrical physiological signals of the group to be processed by at least two selected detection channels of the multiple detection channels.

**[0038]** According to an embodiment of the invention there is provided a monitor that includes an adaptor for directing an electrical physiological signal to multiple detection channels and an adder or a redistribution circuit for adding the

outputs of the multiple detection channels to provide an enhanced signal of better quality. The adaptor and/or the adder may be static or configurable. The adaptor may precede the detection channels, and may be included in the input physiological interface.

#### BRIEF DESCRIPTION OF THE DRAWINGS

**[0039]** In order to understand the invention and to see how it may be carried out in practice, a preferred embodiment will now be described, by way of non-limiting example only, with reference to the accompanying drawings, in which:

**[0040]** FIG. 1 illustrates a person and a prior art monitor;

**[0041]** FIG. 2 illustrates a monitor according to an embodiment of the invention;

**[0042]** FIG. 3 illustrates a monitor according to an embodiment of the invention;

**[0043]** FIG. 4 illustrates detection channels according to an embodiment of the invention;

**[0044]** FIG. 5 illustrates detection channels according to an embodiment of the invention;

**[0045]** FIG. 6 illustrates detection channels according to an embodiment of the invention;

**[0046]** FIG. 7 illustrates an output switching circuit according to an embodiment of the invention;

**[0047]** FIG. 8 illustrates a monitor according to an embodiment of the invention;

**[0048]** FIG. 9 illustrates a monitor according to an embodiment of the invention; and

**[0049]** FIG. 10 illustrates a method according to an embodiment of the invention.

**[0050]** It will be appreciated that for simplicity and clarity of illustration, elements shown in the figures have not necessarily been drawn to scale. For example, the dimensions of some of the elements may be exaggerated relative to other elements for clarity. Further, where considered appropriate, reference numerals may be repeated among the figures to indicate corresponding or analogous elements.

#### DETAILED DESCRIPTION OF THE DRAWINGS

**[0051]** According to an embodiment of the invention there may be provided a monitor that may include multiple detection channels, each detection channel includes an analog conditioning circuit for amplifying and filtering electrical physiological signals received by multiple electrodes such as intra body electrodes for intra-cardiac ECG or electrodes embedded in wearable EEG devices.

**[0052]** The monitor may be a health monitor or may monitor a person for other reasons (not related to health). For example the monitor may be used to generate commands or decisions based upon monitored electrical physiological signals of a person. For example, the monitor may be a wearable EEG device that monitors electrical physiological signals for gaming purposes, controlling electronic devices, assisting in disable person to control devices and/or to communicate, and the like.

**[0053]** Each detection channel may exhibit high input impedance.

**[0054]** The monitor may measure a signal provided by a single electrode or by a plurality of channels in parallel.

**[0055]** In order to measure a signal by the plurality of channels the monitor is arranged to (a) distribute signals between the multiple detection channels and (b) to add processed signals from the multiple detection channels.

**[0056]** The distribution may be performed in the analog domain while the redistribution may be performed in the analog domain or in the digital domain. Performing the adding in the digital domain may assist in compensating noises and/or inaccuracies resulting from the analog to digital conversion.

**[0057]** FIG. 2 illustrates a monitor **120** according to an embodiment of the invention.

**[0058]** Monitor **120** includes a physiological input interface **130**, multiple (N) detection channels **180(1)-180(N)**, a distribution circuit **111**, a redistribution circuit **112**, a display **90**, WCT reference circuit **70**, controller **190** and input module **170**.

**[0059]** Controller **190** controls the operation of the monitor **120** and especially controls the configuration of distribution circuit **111** and redistribution circuit **112**.

**[0060]** N is a positive integer that exceeds three.

**[0061]** Input module **170** may be a keyboard, a mouse, a touch screen (that may or may not be display **90**) for receiving instructions from a user of the monitor **120**.

**[0062]** The user may instruct monitor **120** to operate in a first mode (also referred as to a serial mode) in which each detection channel operates independently from each other and any electrical physiological signal is processed by up to a single detection channel.

**[0063]** The user may instruct monitor **120** to operate in a second mode during which at least one electrical physiological signal is processed by two or more detection channels. See, for example, FIGS. 4, 5 and 6.

**[0064]** Physiological input interface **130** includes multiple conductors **132(1)-132(N)** that are coupled between N electrodes that contact person **10** and the N detection channels **180(1)-180(N)**.

**[0065]** It is noted that any one of the electrodes and/or the conductors may be disconnected (not be used). Additionally or alternatively, the monitor **120** may include unused electrodes and conductors that are not illustrated in FIG. 2.

**[0066]** In FIG. 2 the physiological input interface **130** is illustrated as being an intercardiac catheter but this is not necessarily so. For example (see FIG. 3) the physiological input interface may be a set of EEG conductors.

**[0067]** Each one of the N detection channels may include an analog signal conditioning circuit, an ADC and a digital processing circuit.

**[0068]** For simplicity of explanation only the first and N'th detection channels are illustrated as including an analog signal conditioning circuit (**181(1)** and **181(N)** respectively) and a digital processing circuit (**181(1)** and **181(N)** respectively).

**[0069]** Each one of the detection channels may have high input impedance. The distribution of an electrical physiological signal between two or more detection channels may not distort (or only insignificantly distort) the distributed electrical physiological signals.

**[0070]** The multiple detection channels (or at least some of the N detection channels) may be coupled to in parallel to each other by (a) distribution circuit **111** for distributing signals between the detection channels and (b) by redistribution circuit **112** for adding processed signals from the plurality of detection channels.

**[0071]** The distributed signals may include the electrical physiological signals provided by the physiological input interface **130** or partially processed electrical physiological signals (for example filtered electrical physiological sig-

nals). In FIGS. 4-6 the distributed signals are already high pass filtered before being distributed.

**[0072]** The processed signals that are summed by the redistribution circuit **112** may be digitally processed signals, analog processed signal and the like.

**[0073]** The distribution circuit **111** may distribute any electrical physiological signal to any detection channel or may distribute any electrical physiological signal to a subset of the detection channels.

**[0074]** The number of parallelly connected channels may be dynamic (between two detection channels up to all of the multiple detection channels) and may be determined (by the user) according to the resolution fine details the user wants to observe in the sensed ECG or EEG signal.

**[0075]** According to an embodiment of the invention some of the detection channels may operate in a "serial" manner (single detection channel per electrical physiological signal) while other detection channels may work in parallel to each other (and process the same electrical physiological signal). See, for example, FIG. 6.

**[0076]** The user may request to focus on two or more electrical physiological signals at the same time and there may be multiple groups of detection channels—each group operates in parallel on one of these focused electrical physiological signals.

**[0077]** FIG. 2 also illustrates an ECG waveform **192(2)** that is obtained by summing (or applying a weighted sum) on output signals of two or more detection channels.

**[0078]** FIG. 3 illustrates the monitor **120** as performing an EEG measurement.

**[0079]** FIG. 4 illustrates three detection channels **180(1)**, **180(2)** and **180(3)** and a switching circuit of monitor **120** according to an embodiment of the invention.

**[0080]** It is assumed, for simplicity of explanation, that the three detection channels operate in parallel to process the electrical physiological signal received from second conductor **132(2)**.

**[0081]** Each detection channel includes a pair of radio frequency (RF) filters.

**[0082]** First detection channel **180(1)** includes (a) a first RF filter **201(1)** for filtering the electrical physiological signal received from first conductor **132(1)** to provide a first RF filtered signal and (b) a first reference RF filter **202(1)** for filtering reference signal **72**.

**[0083]** Second detection channel **180(2)** includes (a) a second RF filter **201(2)** for filtering the electrical physiological signal received from second conductor **132(2)** to provide a second RF filtered signal and (b) a second reference RF filter **202(2)** for filtering reference signal **72**.

**[0084]** Third detection channel **180(3)** includes (a) a third RF filter **201(3)** for filtering the electrical physiological signal received from third conductor **132(3)** to provide a third RF filtered signal and (b) a third reference RF filter **202(3)** for filtering reference signal **72**.

**[0085]** The pair of RF filters are followed by an input switching unit that may be a part of the distribution circuit.

**[0086]** Each input switching circuit includes a main input, a top input and a bottom input. The main input is used for receiving a main filtered RF signal—the filtered RF signal from the RF filter that belong to the same detection channel as the input switching circuit.

**[0087]** The terms "top", "above", "bottom" and "below" are used to distinguish between two detection channels that may be coupled to a given detection channel. These terms

refer to an arbitrary order of the detection channels. For example—second detection channel is above third detection channel and below first detection channels.

**[0088]** The top input is used for receiving a top filtered RF signal from an RF filter that belongs to a detection channel that is “above” the detection channel of the input switching circuit.

**[0089]** The bottom input is used for receiving a bottom filtered RF signal from an RF filter that belongs to a detection channel that is “below” the detection channel of the input switching circuit.

**[0090]** Each input switching circuit may select which filtered RF signal (out of the main filtered RF signal, the top filtered RF signal and the bottom filtered RF signal) to output. In FIG. 4 each input switching circuit include a main switch, a top switch and a bottom switch for performing the selection.

**[0091]** First detection channel **180(1)** includes first input switching circuit **210(1)** that includes a first main input, first top input **214(1)**, first bottom input **215(1)**, first main switch **S11 211(1)**, first top switch **S12 212(1)** and first bottom switch **S13 213(1)**.

**[0092]** Second detection channel **180(2)** includes second input switching circuit **210(2)** that includes a second main input, second top input **214(2)**, second bottom input **215(2)**, second main switch **S21 211(2)**, second top switch **S22 212(2)** and second bottom switch **S23 213(2)**.

**[0093]** Third detection channel **180(3)** includes third input switching circuit **210(3)** that includes a third main input, third top input **214(3)**, third bottom input **215(3)**, third main switch **S31 211(3)**, third top switch **S32 212(3)** and third bottom switch **S33 213(3)**.

**[0094]** Each input switching circuit includes an amplifier (such as a differential amplifier) that receives a filtered RF reference signal and an output signal of the input switching circuit.

**[0095]** First till third detection channels **180(1)**, **180(2)** and **180(3)** include first, second and third amplifiers **220(1)**, **220(2)** and **220(3)** respectively.

**[0096]** In FIG. 4 it is assumed that the electrical physiological signal from the second conductor **132(2)** is processed by the three detection channels.

**[0097]** Table 1 illustrates the state of various switches. Open (disconnected) is represented by 0 and closed (connected) is represented by 1.

TABLE 1

S11	S12	S13	S21	S22	S23	S31	S22	S23
0	0	1	1	1	1	0	1	0

**[0098]** In each detection channel the amplifier is followed by an analog low pass filter (LPF). The pair of input RF signals, the input switching circuit, the amplifier and the analog LPF form an analog conditioning circuit.

**[0099]** First till third detection channels **180(1)**, **180(2)** and **180(3)** include first analog LPF **230(1)**, second analog LPF **230(2)** and third analog LPF **230(3)** respectively.

**[0100]** First detection channel **180(1)** includes a first analog conditioning circuit **200(1)**. First analog conditioning circuit **200(1)** includes first RF filter **201(1)**, first reference RF filter **202(1)**, first input switching circuit **210(1)**, first amplifier **220(1)** and first analog LPF **230(1)**.

**[0101]** The second detection channel **180(2)** includes a second analog conditioning circuit **200(2)**. Second analog conditioning circuit **200(2)** includes second RF filter **201(2)**, second reference RF filter **202(2)**, second input switching circuit **210(2)**, second amplifier **220(2)** and second analog LPF **230(2)**.

**[0102]** The third detection channel **180(3)** includes a third analog conditioning circuit **200(3)**. Third analog conditioning circuit **200(3)** includes third RF filter **201(3)**, third reference RF filter **202(3)**, third input switching circuit **210(3)**, third amplifier **220(3)** and third analog LPF **230(3)**.

**[0103]** In each detection channel the analog conditioning circuit is followed by an ADC that is followed by real time (RT) digital filters. The RT digital filters are followed by an output switching circuit that belongs to the redistribution circuit.

**[0104]** Each output switching circuit includes a main input, a top switch, a bottom switch and an output switch.

**[0105]** The main input is used for receiving a main digitally filtered signal—the digitally filtered signal from the RT digital filters that belong to the same detection channel as the output switching circuit.

**[0106]** The output switch is used to determine whether an output signal of the adder is provided to a display and be displayed by the display.

**[0107]** The top switch may be in an input position, an open position and an output position.

**[0108]** When in an input position the top switch is used for feeding the adder (of the output switching circuit of the top switch) with signals from an output switching circuit of a top detection channel that is “above” the detection channel of the output switching circuit.

**[0109]** When in an output position the top switch is used for feeding the adder (of the output switching circuit of the top switch) with signals from an output switching circuit of a top detection channel with an output of the adder (of the output switching circuit of the top switch).

**[0110]** When in an open position the output switching circuits of the top detection channel and of the top switch are disconnected.

**[0111]** The bottom switch may be in an input position, an open position and an output position.

**[0112]** When in an input position the bottom switch is used for feeding the adder (of the output switching circuit of the bottom switch) with signals from an output switching circuit of a bottom detection channel that is “below” the detection channel of the output switching circuit.

**[0113]** When in an output position the bottom switch is used for feeding the output switching circuit of the bottom detection channel with an output of the adder (of the output switching circuit of the bottom switch).

**[0114]** When in an open position the output switching circuits of the bottom detection channel and of the bottom switch are disconnected.

**[0115]** Referring to FIG. 4—first detection channel includes first output switching circuit **260(1)**. First output switching circuit **260(1)** includes first adder **263(1)**, first top switch **S15 265(1)**, first bottom switch **S16 266(1)** and first output switch **S14 264(1)**. First top switch **S15 265(1)** and first bottom switch **S16 266(1)** are in an input mode when they are connected to an input of the adder (oriented to the left), are in an output mode when they are connected to the output of the adder (oriented to the right) or disconnected (vertical).

[0116] Second detection channel includes second output switching circuit 260(2). Second output switching circuit 260(2) includes second adder 263(2), second top switch S15 265(2), second bottom switch S16 266(2) and second output switch S14 264(2). Second top switch S15 265(2) and second bottom switch S16 266(2) are in an input mode when they are connected to an input of the adder (oriented to the left), are in an output mode when they are connected to the output of the adder (oriented to the right) or disconnected (vertical).

[0117] Third detection channel include third output switching circuit 260(3). Third output switching circuit 260(3) includes third adder 263(3), third top switch S15 265(3), third bottom switch S16 266(3) and third output switch S14 264(3). Third top switch S15 265(3) and third bottom switch S16 266(3) are in an input mode when they are connected to an input of the adder (oriented to the left), are in an output mode when they are connected to the output of the adder (oriented to the right) or disconnected (vertical).

[0118] Because there are more than two detection channels then signals from another detection channel may be digitally filtered signal that was only processed by the other detection signals or may be a sum of digitally filtered signals that were processed by two or more other detection channels.

[0119] In FIG. 4 it is assumed that the second output switching circuit sums the output signals from the first and third output switching circuits and outputs its output signal to the display.

[0120] Table 2 illustrates the state of various switches. Input position is represented by In, output position is represented by Out, disconnected is represented by 0 and connected is represented by 1.

TABLE 2

S15	S16	S14	S25	S26	S24	S35	S36	S34
0	Out	0	In	In	1	Out	0	0

[0121] FIG. 5 illustrates three detection channels 180(1), 180(2) and 180(3) and a switching circuit of monitor 120 according to an embodiment of the invention.

[0122] It is assumed, for simplicity of explanation, that the three detection channels operate in parallel to process the electrical physiological signal received from third conductor 132(3).

[0123] Table 3 illustrates the state of various switches. Open (disconnected) is represented by 0 and closed (connected) is represented by 1.

TABLE 3

S11	S12	S13	S21	S22	S23	S31	S22	S23
0	0	1	0	1	1	1	1	0

[0124] Table 4 illustrates the state of various switches. Input position is represented by In, output position is represented by Out, disconnected is represented by 0 and connected is represented by 1.

TABLE 4

S15	S16	S14	S25	S26	S24	S35	S36	S34
0	Out	0	In	Out	0	In	0	1

[0125] FIG. 6 illustrates three detection channels 180(1), 180(2) and 180(3) and a switching circuit of monitor 120 according to an embodiment of the invention.

[0126] It is assumed, for simplicity of explanation, that the first two detection channels operate in parallel to process the electrical physiological signal received from second conductor 132(2) and that the third detection signal operated in a serial manner to process the electrical physiological signal received from first conductor 132(1).

[0127] Table 5 illustrates the state of various switches. Open (disconnected) is represented by 0 and closed (connected) is represented by 1.

TABLE 5

S11	S12	S13	S21	S22	S23	S31	S22	S23
0	0	1	1	1	1	1	0	0

[0128] Table 6 illustrates the state of various switches. Input position is represented by In, output position is represented by Out, disconnected is represented by 0 and connected is represented by 1.

TABLE 6

S15	S16	S14	S25	S26	S24	S35	S36	S34
0	Out	0	In	Out	0	0	0	1

[0129] The top and bottom switches of the output switching circuit may be included in or replaced by a top IO interface and a bottom IO interface.

[0130] FIG. 7 illustrates an output switching circuit 300 according to an embodiment of the invention.

[0131] Output switching circuit 300 includes adder 340, top switch 310, bottom switch 320 and output switch 330.

[0132] Top switch 310 includes a top input multiplexer 301 and a top output multiplexer 302.

[0133] Bottom switch 302 includes a top input multiplexer 301 and a top output multiplexer 302.

[0134] Output switch 330 includes output multiplexer 304.

[0135] The top input multiplexer 301 has a first input that is fed by zero, a second input that is connected to a top output switching circuit and is controlled by a select signal S3i for selecting between the first and second inputs. The output of the top input multiplexer 301 is connected to an input of adder 340.

[0136] The bottom input multiplexer 305 has a first input that is fed by zero, a second input that is connected to a bottom output switching circuit and is controlled by a select signal S4i for selecting between the first and second inputs. The output of the bottom input multiplexer 305 is connected to another input of adder 340.

[0137] The output multiplexer 304 has a first input that is fed by zero, a second input that is connected to the output of adder 340 and is controlled by a select signal S5 for selecting



between the first and second inputs. The output of the output multiplexer 304 is the output port of the output switching circuit 300.

[0138] The top output multiplexer 302 has a first input that is fed by zero, a second input that is connected to the output of adder and is controlled by a select signal S3o for selecting between the first and second inputs and by an enable signal S3e. The output of the top output multiplexer 301 is connected to a top output switching circuit.

[0139] The bottom output multiplexer 302 has a first input that is fed by zero, a second input that is connected to the output of adder and is controlled by a select signal S4o for selecting between the first and second inputs and by an enable signal S4e. The output of the bottom output multiplexer 301 is connected to a bottom output switching circuit.

[0140] Table 7 illustrates the control signals at various modes. Open (disconnected) is represented by 0, closed (connected) is represented by 1 and don't care is represented by x.

TABLE 7

S3e	S3i	S3o	S4e	S4i	S4o	S5	
1	0	0	0	0	0	1	Serial mode
0	1	X	0	1	X	1	Add both top and bottom
1	0	1	0	1	X	0	Add from top only
0	1	X	1	0	1	0	Add from bottom only

[0141] FIG. 8 illustrate monitor 120 according to an embodiment of the invention.

[0142] Monitor 120 of FIG. 8 differs from monitor of FIG. 2 by including a decision module 400 for making decisions and/o generating commands based upon the output signals of the detection channels.

[0143] The decision module 400 may translate outputs of one or more channels to commands. The decision module 400 may receive or generate a mapping between output signals of detection channels and commands.

[0144] FIG. 9 illustrate monitor 120 according to an embodiment of the invention.

[0145] Monitor 120 of FIG. 9 differs from monitor of FIG. 3 by including a decision module 400 for making decisions and/o generating commands based upon the output signals of the detection channels. An additional difference is the replacement of monitor 90 and input module 170 by an output interface 177. The interface 177 may be a man machine interface (such as a display, a keyboard, a mouse), a receiver, a transmitter, and the like. Interface 177 may transmit commands to the appropriate device (for example a part of an entertainment module), receive instructions and/or information (mapping) and the like. It is noted that interface 177 may replace (or be included in addition to) the display illustrated in various other figures.

[0146] FIG. 10 illustrates method 600 according to an embodiment of the invention.

[0147] Method 600 starts by steps 610 and 620.

[0148] Step 610 may include receiving, by input ports of a monitor, a group of electrical physiological signals from the person.

[0149] Step 620 may include receiving by the monitor an indication about a required mode of operation of the monitor. Step 620 may be replaced by determining by the monitor the required mode. For example, the determining may be

responsive to signal to noise ratio of the received electrical physiological signals or to any other property of the received electrical physiological signals and/or of expected (desired or allowed) properties of the received electrical physiological signals.

[0150] If the monitor should operate in a first mode (also referred to as serial mode) then steps 610 and 620 are followed by step 630 of processing each electrical physiological signal of the group by up to a single detection channel of multiple detection channels of the monitor. Thus—there may be idle detection channels.

[0151] If the monitor should operate in a second mode (also referred to as parallel mode or hybrid mode) then steps 610 and 620 are followed by step 640 of causing one or more of the multiple electrical physiological signals of the group to be processed by at least two selected detection channels of the multiple detection channels.

[0152] A configuration of multiple switching circuits of the monitor when the monitor operates in the first mode differs from a configuration of the multiple switching circuits of the monitor when the monitor operates in the second mode.

[0153] In a hybrid mode one or more electrical physiological signals are processed only by a single detection channel each. One or more other electrical physiological signals are processed by a plurality of detection channels each. See, for example FIG. 6.

[0154] In a fully parallel mode only one electrical physiological signal is processed—and is processed by a plurality of detection channels. See, for example, FIGS. 4 and 5.

[0155] Any combination of any components illustrated in any of the figures is provided.

[0156] Any reference to the term “comprising” or “having” should be interpreted also as referring to “consisting” of “essentially consisting of”. For example—a monitor that comprises certain components can include additional components, can be limited to the certain components or may include additional components that do not materially affect the basic and novel characteristics of the monitor—respectively.

[0157] In the foregoing specification, the invention has been described with reference to specific examples of embodiments of the invention. It will, however, be evident that various modifications and changes may be made therein without departing from the broader spirit and scope of the invention as set forth in the appended claims.

[0158] Moreover, the terms “front,” “back,” “top,” “bottom,” “over,” “under” and the like in the description and in the claims, if any, are used for descriptive purposes and not necessarily for describing permanent relative positions. It is understood that the terms so used are interchangeable under appropriate circumstances such that the embodiments of the invention described herein are, for example, capable of operation in other orientations than those illustrated or otherwise described herein.

[0159] Those skilled in the art will recognize that the boundaries between logic blocks are merely illustrative and that alternative embodiments may merge logic blocks or circuit elements or impose an alternate decomposition of functionality upon various logic blocks or circuit elements. Thus, it is to be understood that the architectures depicted herein are merely exemplary, and that in fact many other architectures can be implemented which achieve the same functionality.

**[0160]** Any arrangement of components to achieve the same functionality is effectively “associated” such that the desired functionality is achieved. Hence, any two components herein combined to achieve a particular functionality can be seen as “associated with” each other such that the desired functionality is achieved, irrespective of architectures or intermedial components. Likewise, any two components so associated can also be viewed as being “operably connected” or “operably coupled” to each other to achieve the desired functionality.

**[0161]** Furthermore, those skilled in the art will recognize that boundaries between the above described operations merely illustrative. The multiple operations may be combined into a single operation, a single operation may be distributed in additional operations and operations may be executed at least partially overlapping in time. Moreover, alternative embodiments may include multiple instances of a particular operation, and the order of operations may be altered in various other embodiments.

**[0162]** Also for example, in one embodiment, the illustrated examples may be implemented as circuitry located on a single integrated circuit or within a same device. Alternatively, the examples may be implemented as any number of separate integrated circuits or separate devices interconnected with each other in a suitable manner.

**[0163]** Also for example, the examples, or portions thereof, may implemented as soft or code representations of physical circuitry or of logical representations convertible into physical circuitry, such as in a hardware description language of any appropriate type.

**[0164]** Also, the invention is not limited to physical devices or units implemented in non-programmable hardware but can also be applied in programmable devices or units able to perform the desired device functions by operating in accordance with suitable program code, such as mainframes, minicomputers, servers, workstations, personal computers, notepads, personal digital assistants, electronic games, automotive and other embedded systems, cell phones and various other wireless devices, commonly denoted in this application as ‘computer systems’.

**[0165]** However, other modifications, variations and alternatives are also possible. The specifications and drawings are, accordingly, to be regarded in an illustrative rather than in a restrictive sense.

**[0166]** In the claims, any reference signs placed between parentheses shall not be construed as limiting the claim. The word ‘comprising’ does not exclude the presence of other elements or steps than those listed in a claim. Furthermore, the terms “a” or “an,” as used herein, are defined as one or more than one. Also, the use of introductory phrases such as “at least one” and “one or more” in the claims should not be construed to imply that the introduction of another claim element by the indefinite articles “a” or “an” limits any particular claim containing such introduced claim element to inventions containing only one such element, even when the same claim includes the introductory phrases “one or more” or “at least one” and indefinite articles such as “a” or “an.” The same holds true for the use of definite articles. Unless stated otherwise, terms such as “first” and “second” are used to arbitrarily distinguish between the elements such terms describe. Thus, these terms are not necessarily intended to indicate temporal or other prioritization of such elements the mere fact that certain measures are recited in mutually

different claims does not indicate that a combination of these measures cannot be used to advantage.

**[0167]** While certain features of the invention have been illustrated and described herein, many modifications, substitutions, changes, and equivalents will now occur to those of ordinary skill in the art. It is, therefore, to be understood that the appended claims are intended to cover all such modifications and changes as fall within the true spirit of the invention.

We claim:

**1.** A monitor that comprises multiple detection channels having multiple input ports for receiving a group of electrical physiological signals from a person;

wherein multiple switching circuits of the monitor are configured according to a first configuration when the monitor operates in a first mode, thereby causing each electrical physiological signal of the group to be processed by up to a single selected detection channel of the multiple detection channels;

wherein the multiple switching circuits of the monitor are configured according to a second configuration when the monitor operates in a second mode thereby causing one or more of the multiple electrical physiological signals of the group to be processed by at least two selected detection channels of the multiple detection channels.

**2.** The monitor according to claim **1** wherein the multiple switching circuits are coupled to multiple analog signal conditioning circuits of the multiple detection channels.

**3.** The monitor according to claim **1** wherein the multiple switching circuits belong to multiple analog signal conditioning circuits of the multiple detection channels.

**4.** The monitor according to claim **3** wherein switching circuits that belong to different detection channels are configured to output different electrical physiological signals when the monitor operates in the first mode; and

wherein a plurality of switching circuits that belong to a plurality of different selected detection channels are configured to output a same electrical physiological signal when the monitor operates in the second mode.

**5.** The monitor according to claim **4** wherein the at least two switching circuits belong to neighboring detection channels.

**6.** The monitor according to claim **4** wherein the at least two switching circuits belong to more than two detection channels.

**7.** The monitor according to claim **4** wherein each switching circuit comprises three or more inputs for receiving three or more electrical physiological signals of the group.

**8.** The monitor according to claim **4** wherein each switching circuit is positioned between different analog components of the analog conditioning circuit.

**9.** The monitor according to claim **4** wherein each switching circuit is a first analog component of the analog conditioning circuit.

**10.** The monitor according to claim **4** wherein each switching circuit is a last analog component of the analog conditioning circuit.

**11.** The monitor according to claim **4** wherein each switching circuit is followed by an analog amplifier of the analog conditioning circuit; wherein the analog amplifier is also fed by a reference signal.

**12.** The monitor according to claim **1** wherein the multiple detection channels comprise multiple analog conditioning

circuits that are followed by multiple analog to digital converters for converting multiple analog output signals of the multiple analog conditioning circuits to multiple intermediate digital signals;

wherein the multiple analog to digital converters are followed by a digital manipulator;

wherein the digital manipulator is prevented from adding intermediate digital signals from analog conditioning circuits of different selected detection channels when the monitor operates in a first mode;

wherein the digital manipulator is configured to add intermediate digital signals from analog conditioning circuits of the at least two selected detection channels when the monitor operates in the second mode.

**13.** The monitor according to claim **12** wherein the digital manipulator comprises a digital manipulation circuit per each detection channel; wherein each digital manipulation circuit is coupled to a set of digital to analog converters of a set of detection channels.

**14.** The monitor according to claim **13** wherein a digital manipulation circuit of a given detection channel that belongs to a given set of detection channels comprises:

a plurality of IO interfaces, each IO interface is coupled to a digital manipulation circuit of another detection channel of the given set;

an adder that has (a) a first input that is coupled to the analog to digital circuit of the given detection channel, (b) an IO interface for each other detection channel of the set, wherein each IO interface is coupled to a digital manipulation circuit of another detection channel of the set, and (c) an adder output;

an output circuit for outputting a digital manipulation circuit output signal;

wherein the output circuit is coupled to the adder output and to each one of the plurality of IO interfaces.

**15.** The monitor according to claim **12** wherein the digital manipulator is followed by a decision module for making decisions based upon output signals of the detection channels.

**16.** The monitor according to claim **1** further comprising a display for displaying multiple output signals of the multiple detection channels.

**17.** The monitor according to claim **15** wherein the display is configured to display an aggregate signal that represents an outcome of the processing each one of the one or more of the multiple electrical physiological signals by the at least two selected detection channels of the multiple detection channels.

**18.** The monitor according to claim **1** wherein the group of physiological signals are electrocardiogram (ECG) signals.

**19.** The monitor according to claim **1** wherein the group of physiological signals are electroencephalogram (EEG) signals.

**20.** The monitor according to claim **1** comprising a controller that is configured to determine an operational mode of the monitor.

**21.** A method for monitoring a person, the method comprises:

receiving, by input ports of a monitor, a group of electrical physiological signals from the person;

wherein the monitor operates in a first mode, processing each electrical physiological signal of the group by up to a single detection channel of multiple detection channels of the monitor;

wherein the monitor operates in a second mode, causing one or more of the multiple electrical physiological signals of the group to be processed by at least two selected detection channels of the multiple detection channels;

wherein a configuration of multiple switching circuits of the monitor when the monitor operates in the first mode differs from a configuration of the multiple switching circuits of the monitor when the monitor operates in the second mode.

**22.** A non-transitory computer readable medium that stores instructions that once executed by a monitor cause the monitor to:

receive, by input ports of a monitor, a group of electrical physiological signals from a person;

wherein the monitor operates in a first mode, processing each electrical physiological signal of the group by up to a single detection channel of multiple detection channels of the monitor;

wherein the monitor operates in a second mode, causing one or more of the multiple electrical physiological signals of the group to be processed by at least two selected detection channels of the multiple detection channels;

wherein a configuration of multiple switching circuits of the monitor when the monitor operates in the first mode differs from a configuration of the multiple switching circuits of the monitor when the monitor operates in the second mode.

\* \* \* \* \*

专利名称(译)	可配置的多通道ECG和EEG监护仪		
公开(公告)号	<a href="#">US20180256063A1</a>	公开(公告)日	2018-09-13
申请号	US15/757376	申请日	2016-09-04
[标]申请(专利权)人(译)	goldminz大勒 陈摩西 SHOHAM约阿夫		
申请(专利权)人(译)	goldminz , LAVY 陈 , MOSHE SHOHAM , 约阿夫		
当前申请(专利权)人(译)	goldminz , LAVY 陈 , MOSHE SHOHAM , 约阿夫		
[标]发明人	GOLDMINZ LAVY CHEN MOSHE SHOHAM YOAV		
发明人	GOLDMINZ, LAVY CHEN, MOSHE SHOHAM, YOAV		
IPC分类号	A61B5/0428 A61B5/04 A61B5/042 A61B5/0476 A61B5/00		
CPC分类号	A61B5/04288 A61B5/04004 A61B5/0422 A61B5/0476 A61B5/7225 A61B5/0006		
优先权	62/214988 2015-09-06 US		
外部链接	<a href="#">Espacenet</a> <a href="#">USPTO</a>		

摘要(译)

一种监视器，包括多个检测通道，所述检测通道具有多个输入端口，用于接收来自人的一组电生理信号；其中，当监视器以第一模式操作时，根据第一配置配置监视器的多个切换电路，从而使得组中的每个电生理信号由多个检测通道中的单个选定检测通道处理；其中，当监视器以第二模式操作时，根据第二配置配置监视器的多个切换电路，从而使该组的多个电生理信号中的一个或多个由该多个的至少两个选定的检测通道处理检测通道。

