



(19) **United States**

(12) **Patent Application Publication**
Al-Ali

(10) **Pub. No.: US 2017/0231537 A1**

(43) **Pub. Date: Aug. 17, 2017**

(54) **ADAPTIVE ALARM SYSTEM**

(52) **U.S. Cl.**

(71) Applicant: **MASIMO Corporation**, Irvine, CA (US)

CPC *A61B 5/14551* (2013.01); *A61B 5/746* (2013.01); *A61B 5/7275* (2013.01); *G08B 29/26* (2013.01)

(72) Inventor: **Ammar Al-Ali**, San Juan Capistrano, CA (US)

(57) **ABSTRACT**

(21) Appl. No.: **15/583,718**

(22) Filed: **May 1, 2017**

Related U.S. Application Data

(63) Continuation of application No. 13/037,184, filed on Feb. 28, 2011.

(60) Provisional application No. 61/309,419, filed on Mar. 1, 2010, provisional application No. 61/328,630, filed on Apr. 27, 2010.

Publication Classification

(51) **Int. Cl.**

A61B 5/1455 (2006.01)
G08B 29/26 (2006.01)
A61B 5/00 (2006.01)

Systems and electronic processes for reducing electronic alarms in a medical patient monitoring system. For example, a system for reducing electronic alarms can include an optical sensor and one or more hardware processors in electronic communication with the optical sensor. The one or more hardware processors can be programmed to measure oxygen saturation values of a patient over a first period of time, determine if at least one oxygen saturation value obtained over the first period of time exceeds a first alarm threshold, determine whether a first alarm should be triggered based on the determination that the at least one oxygen saturation value obtained over the first period of time exceeds the first alarm threshold, determine a second alarm threshold to be applied during a second period of time subsequent to the first period of time, the second alarm threshold replacing the first alarm threshold.

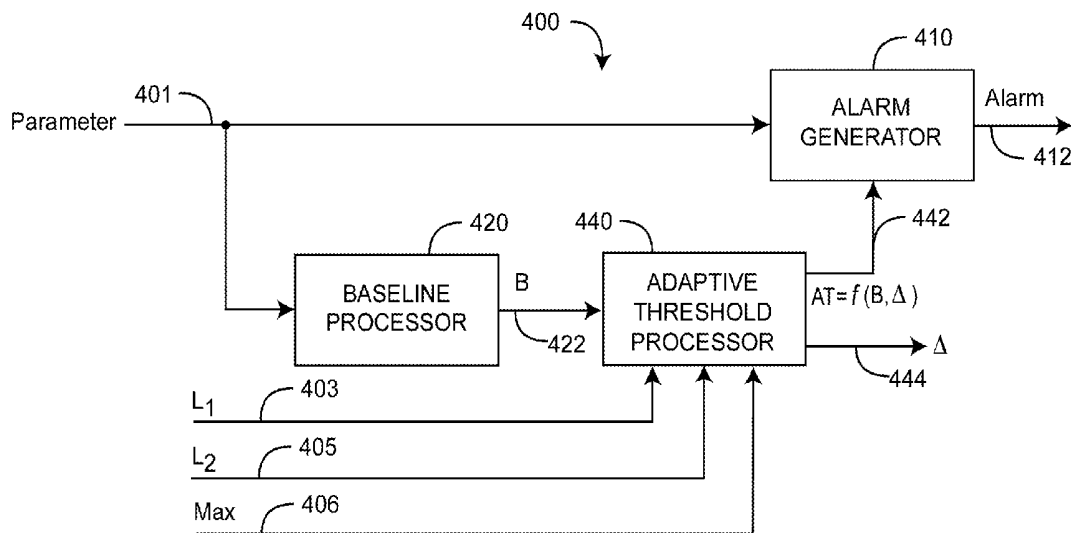

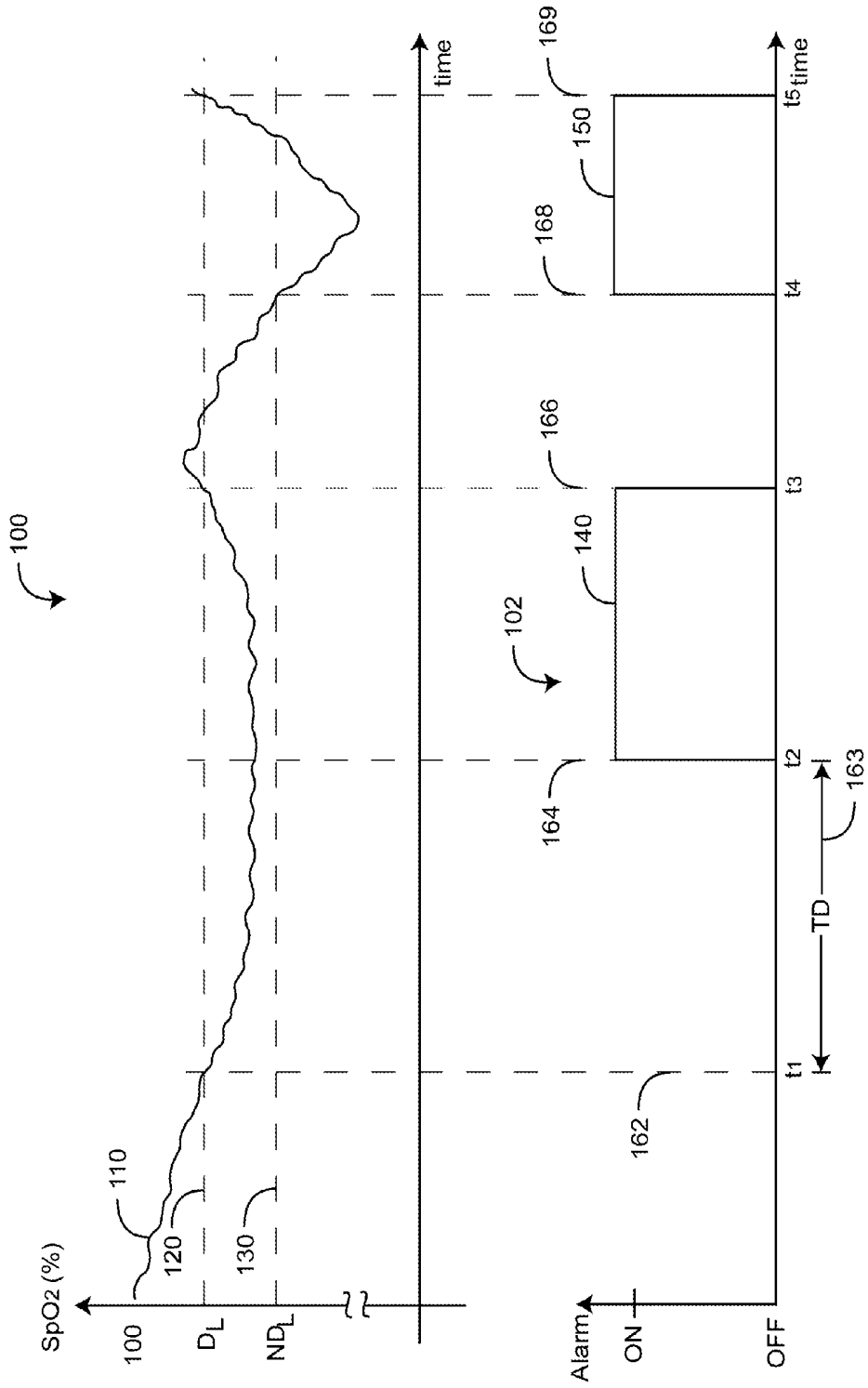

FIG. 1

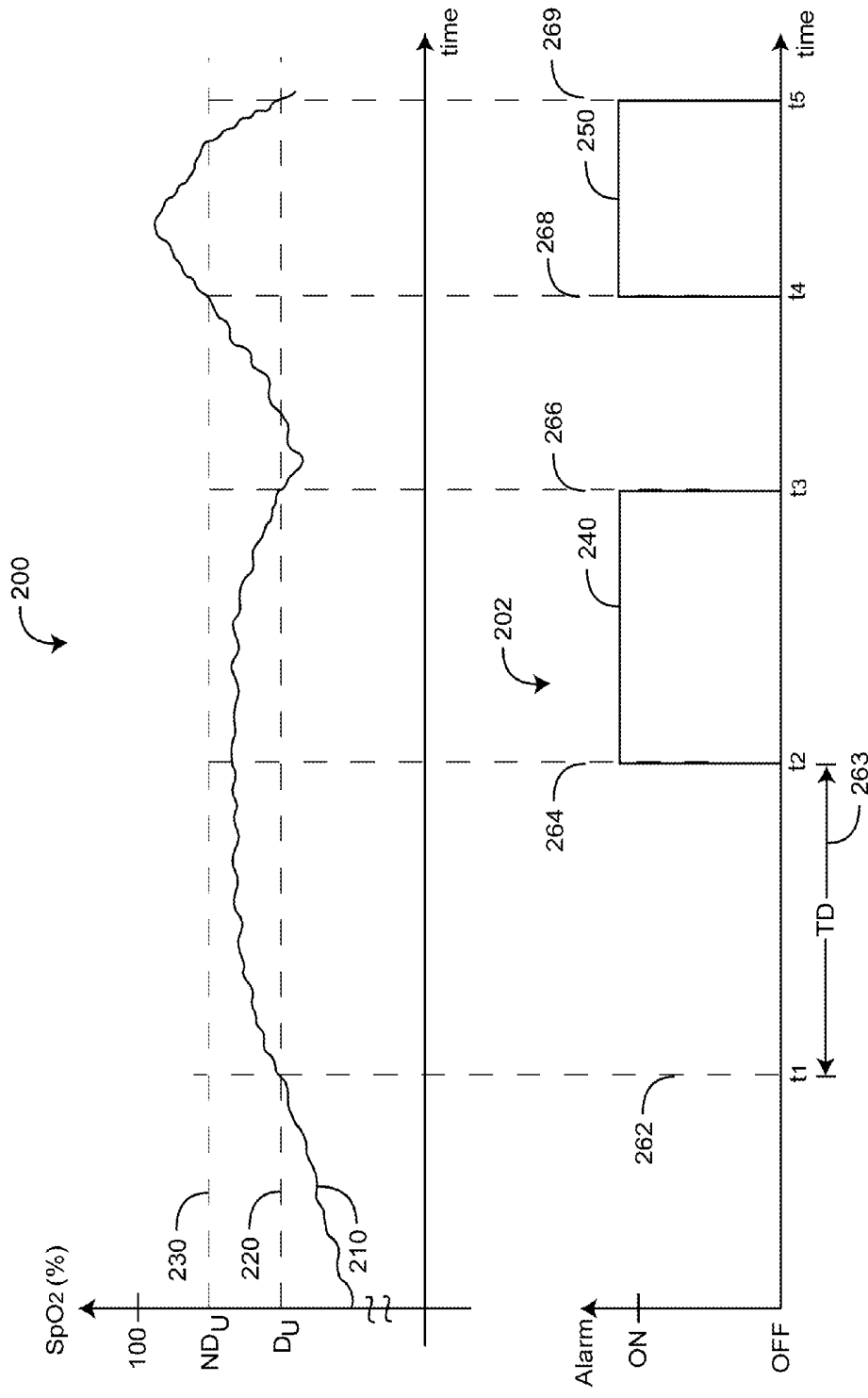

FIG. 2

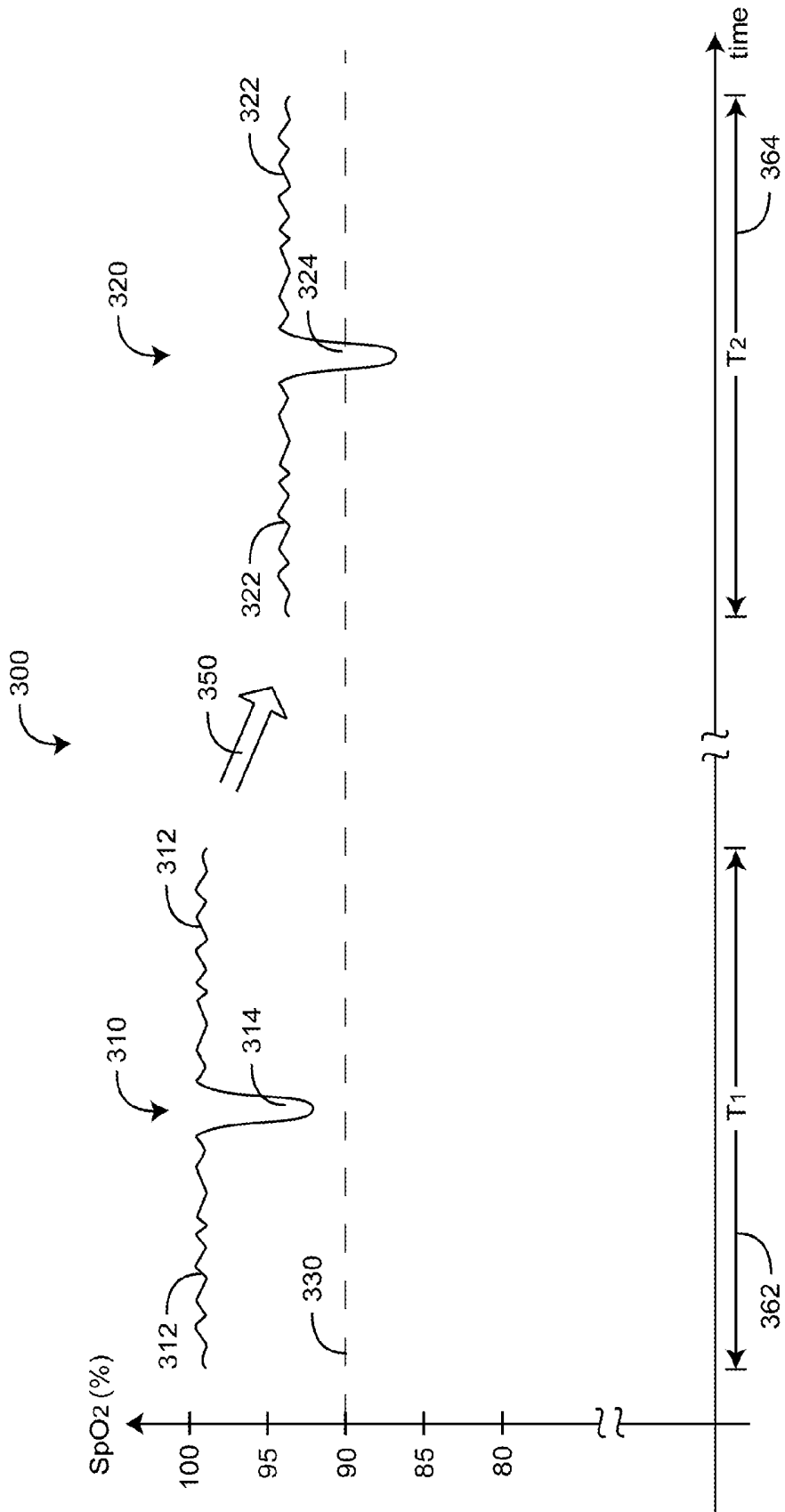

FIG. 3

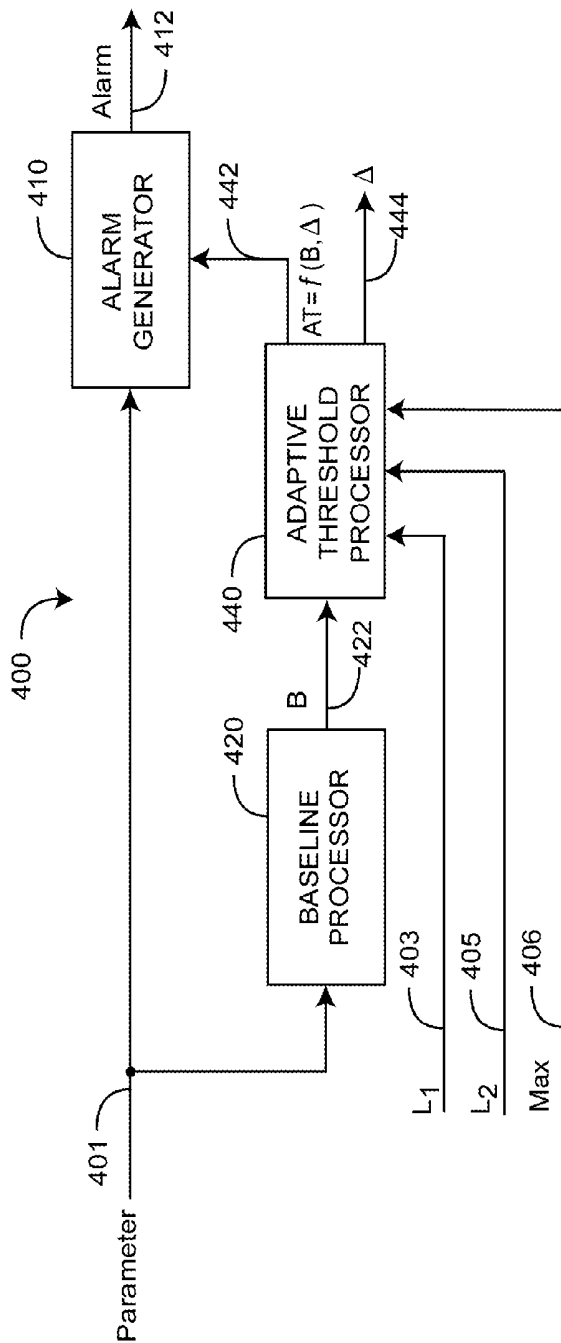

FIG. 4A

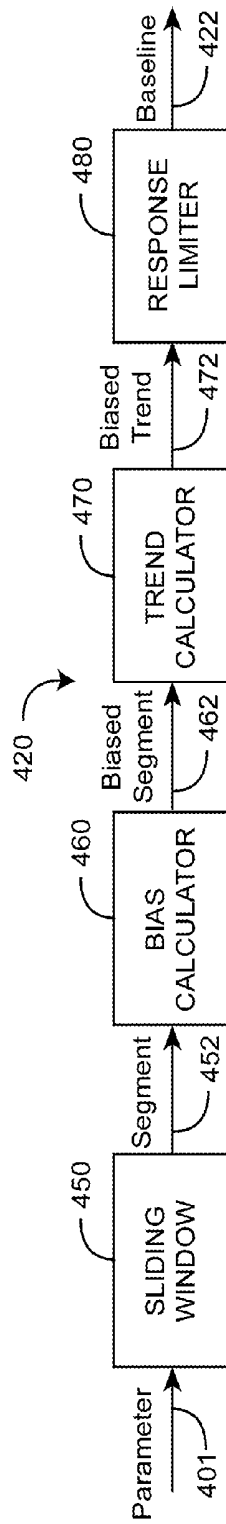

FIG. 4B

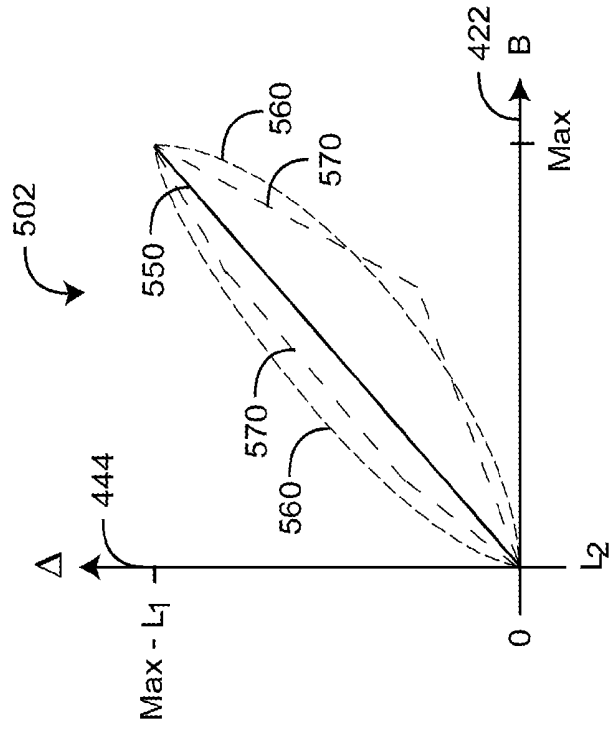

FIG. 5B

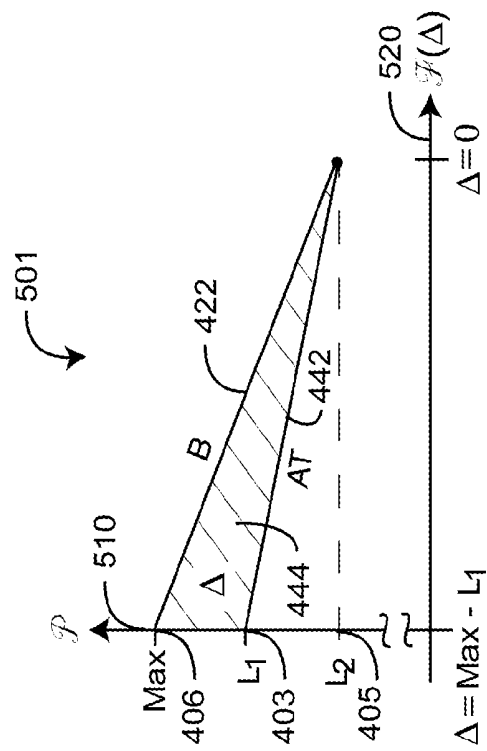

FIG. 5A

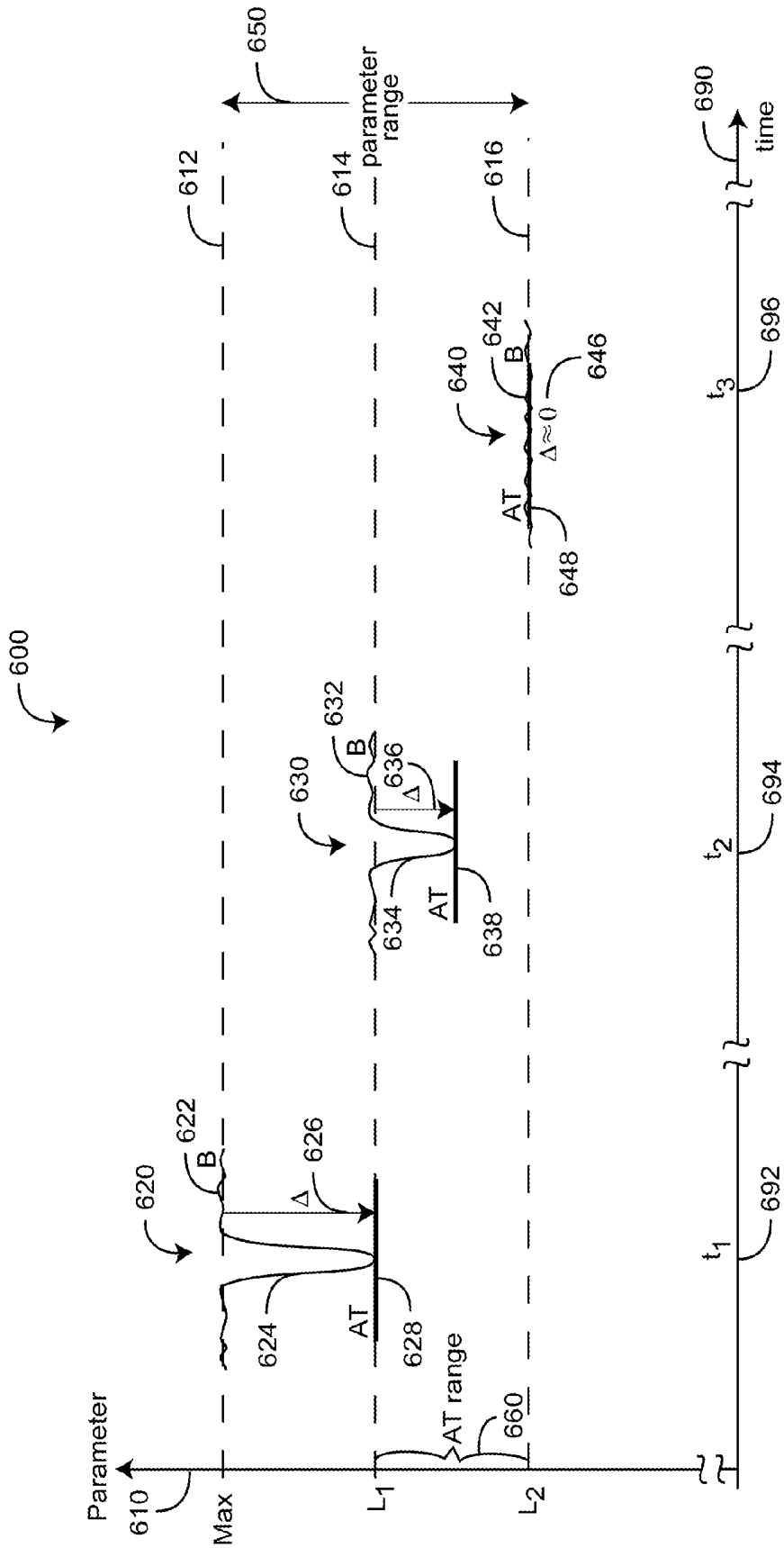

FIG. 6

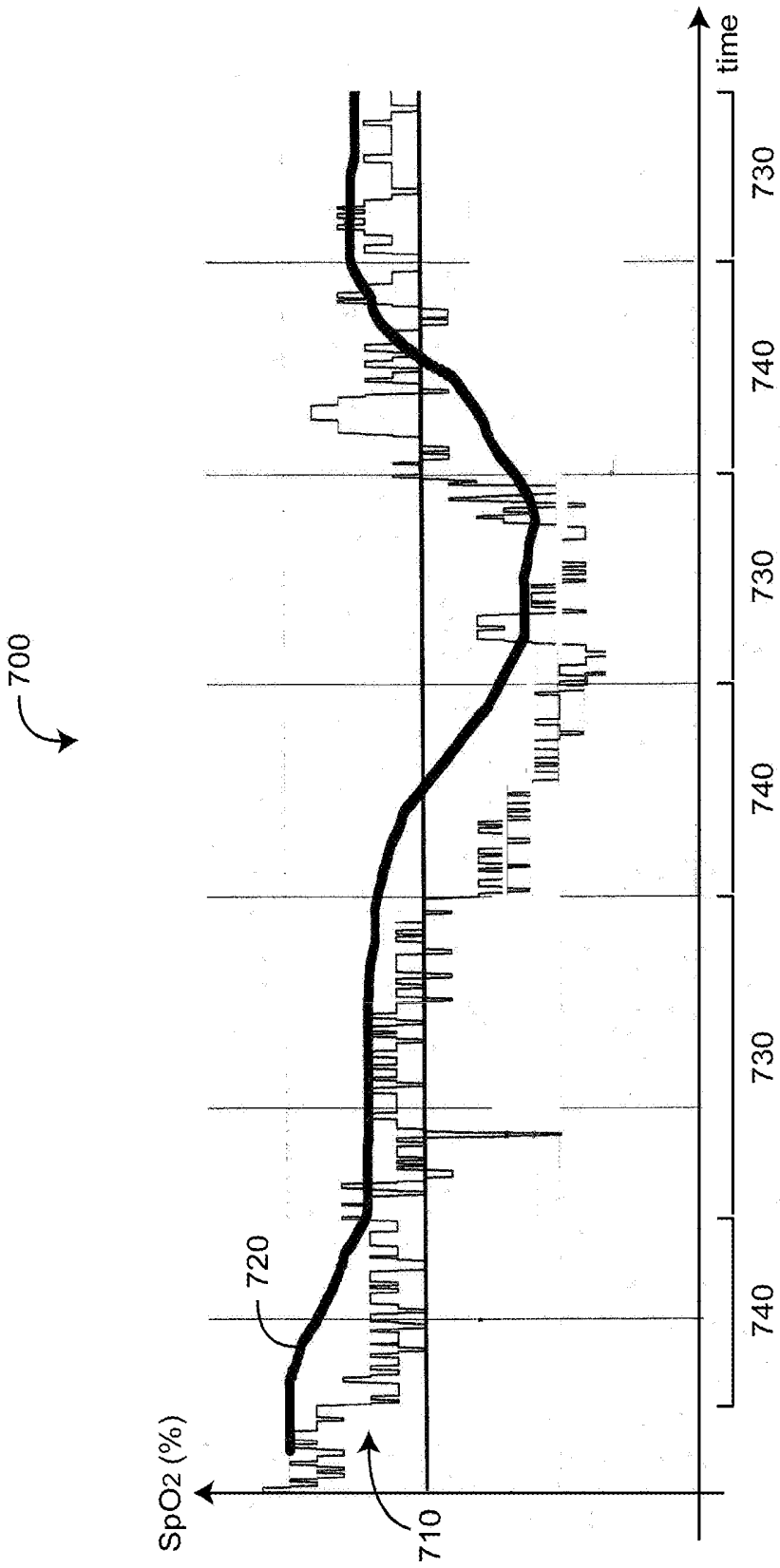

FIG. 7

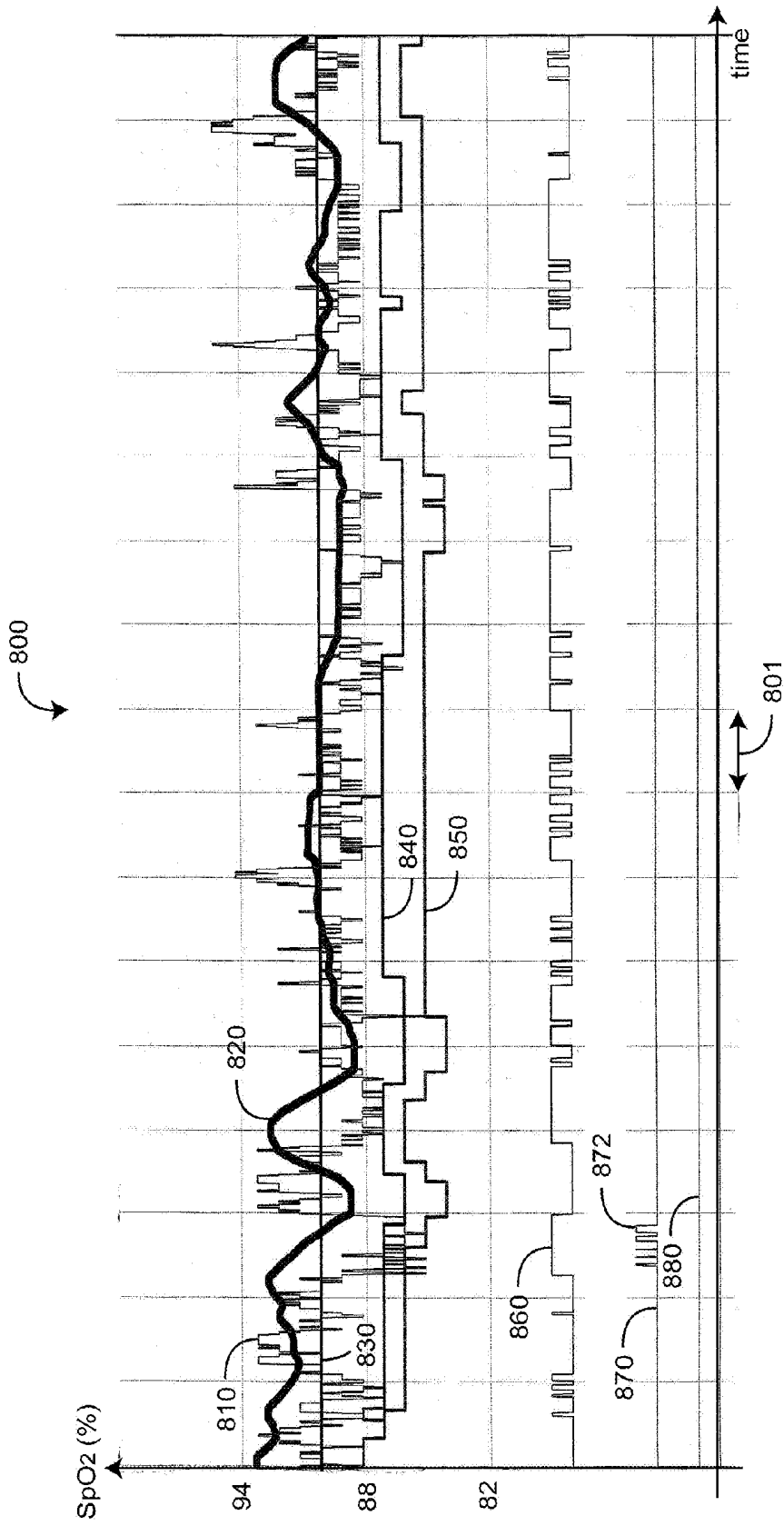

FIG. 8

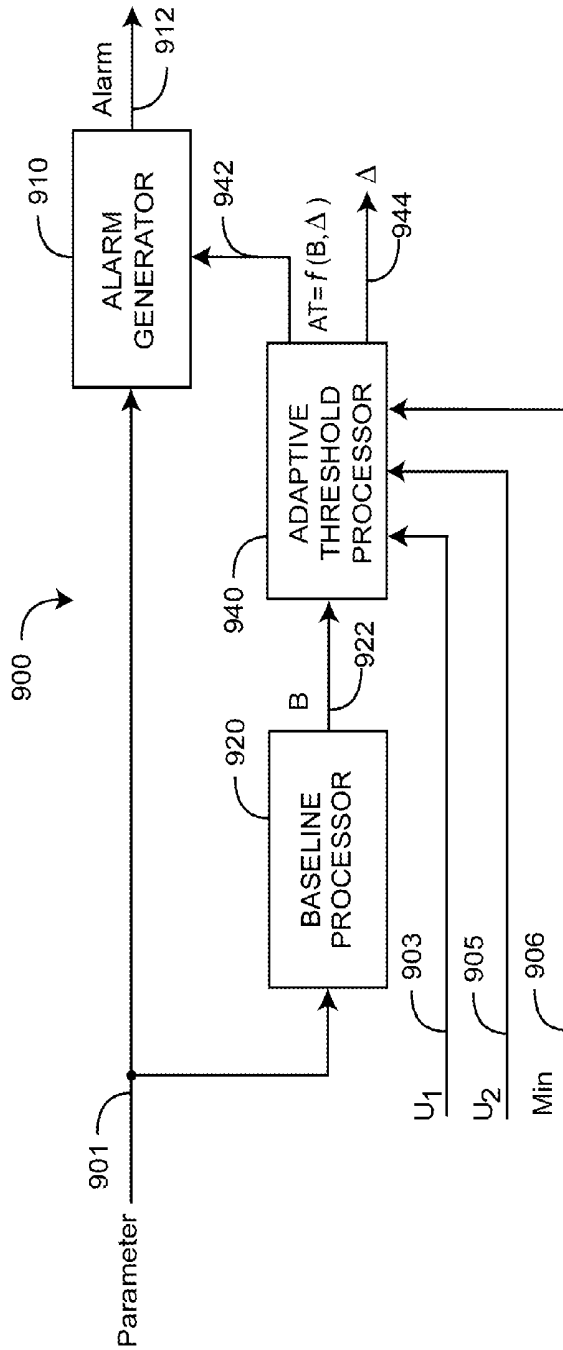

FIG. 9A

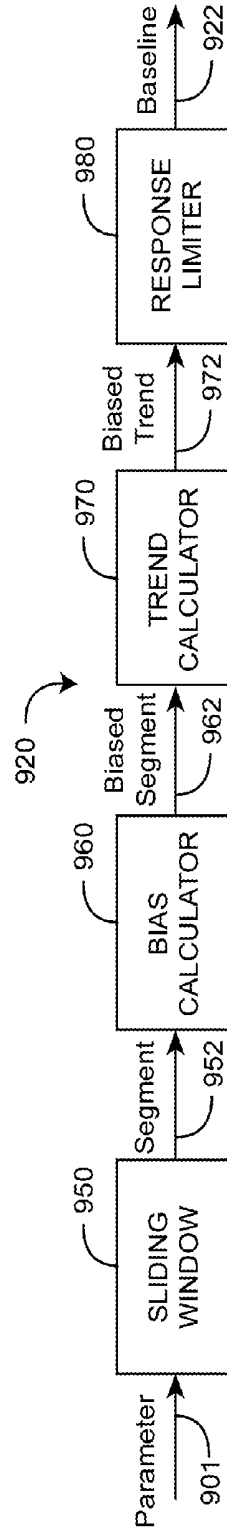

FIG. 9B

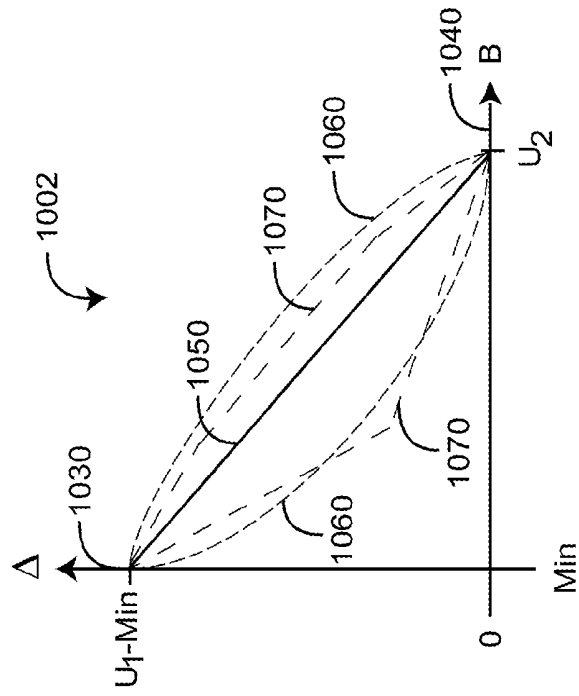

FIG. 10B

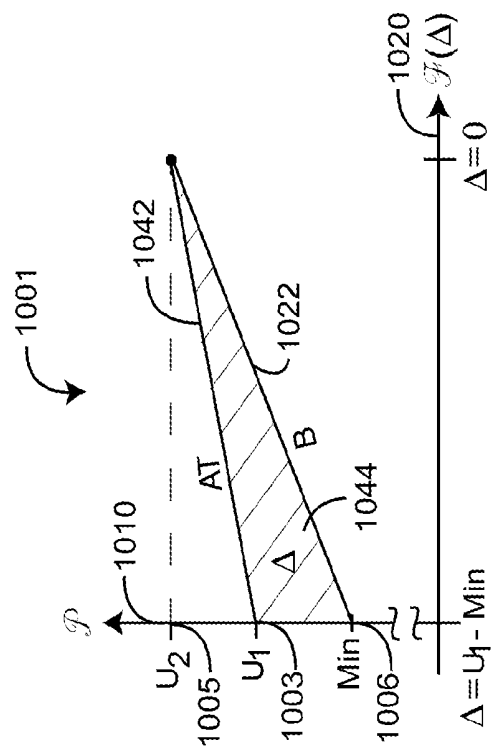

FIG. 10A

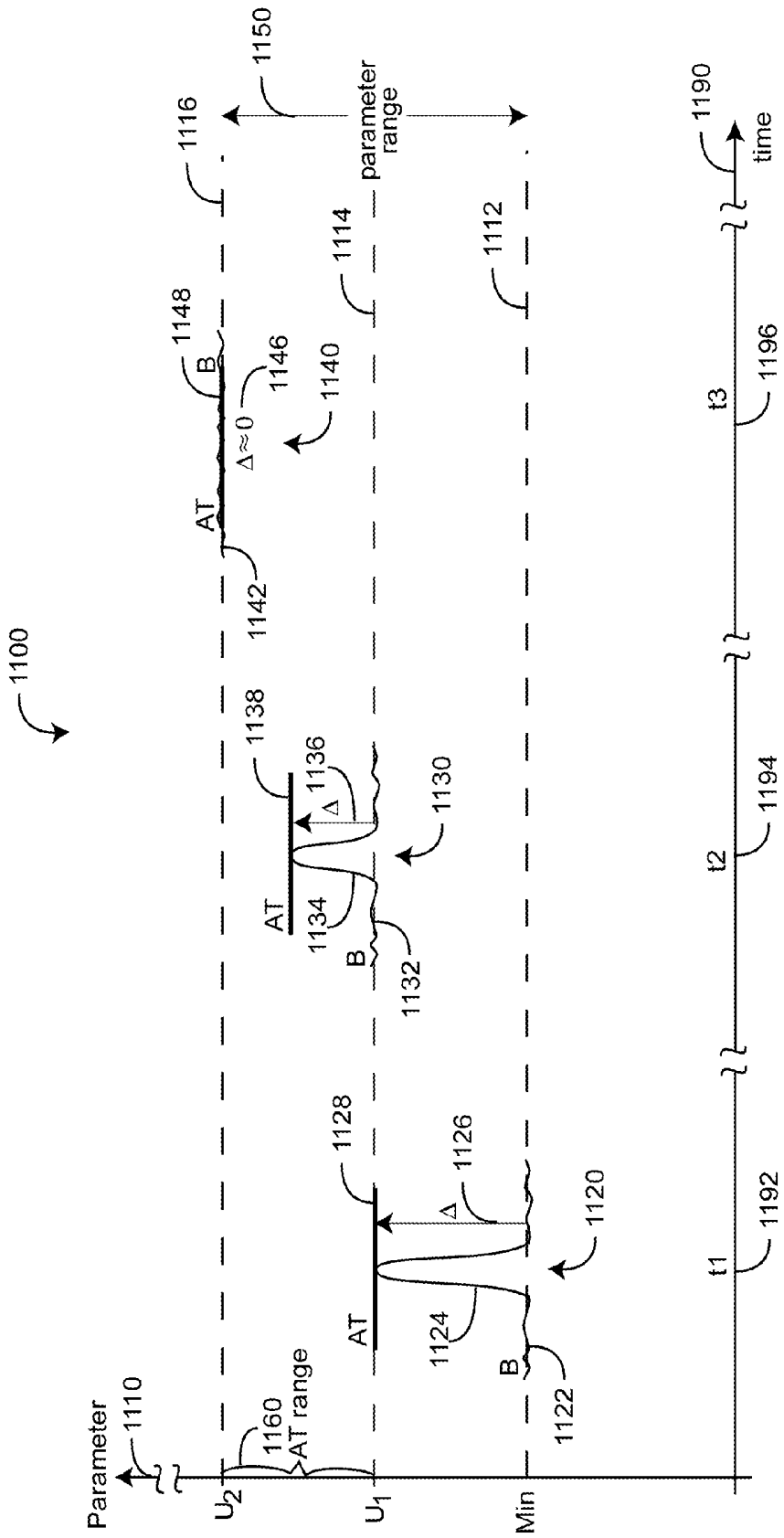

FIG. 11

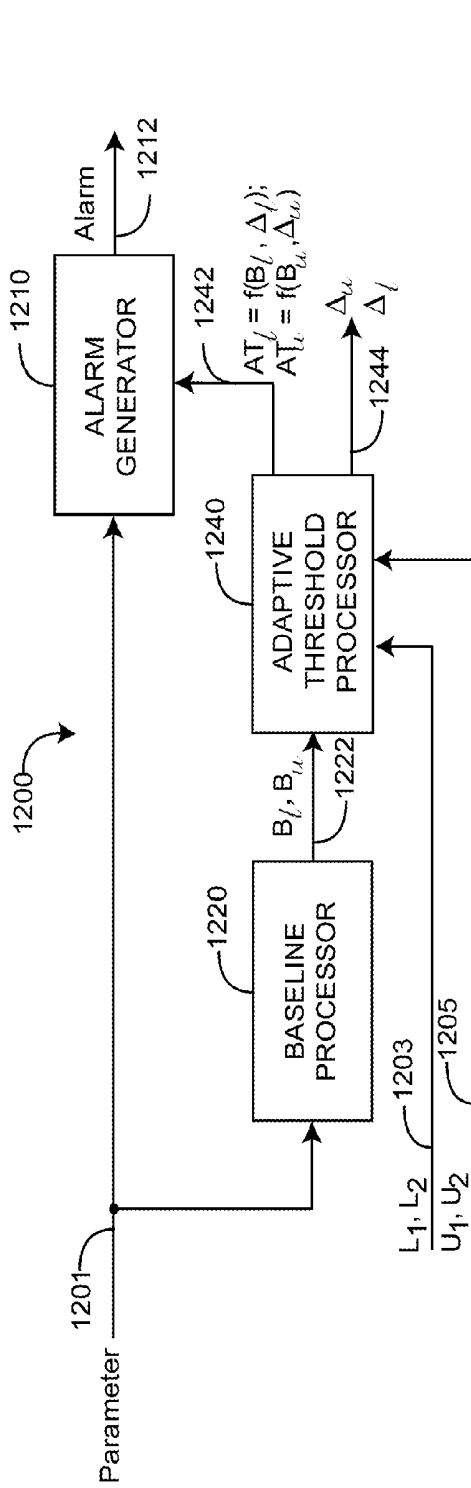

FIG. 12A

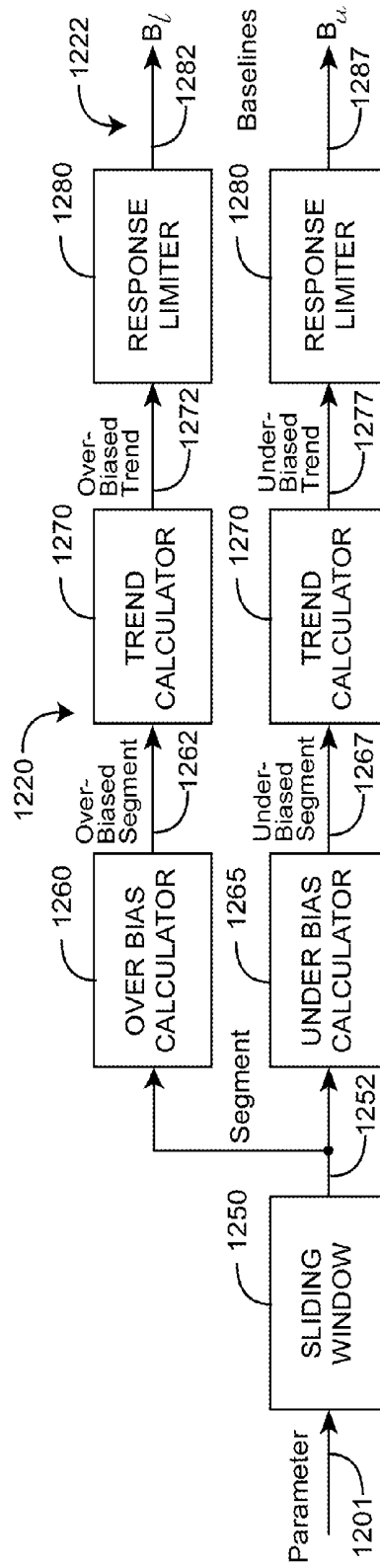

FIG. 12B

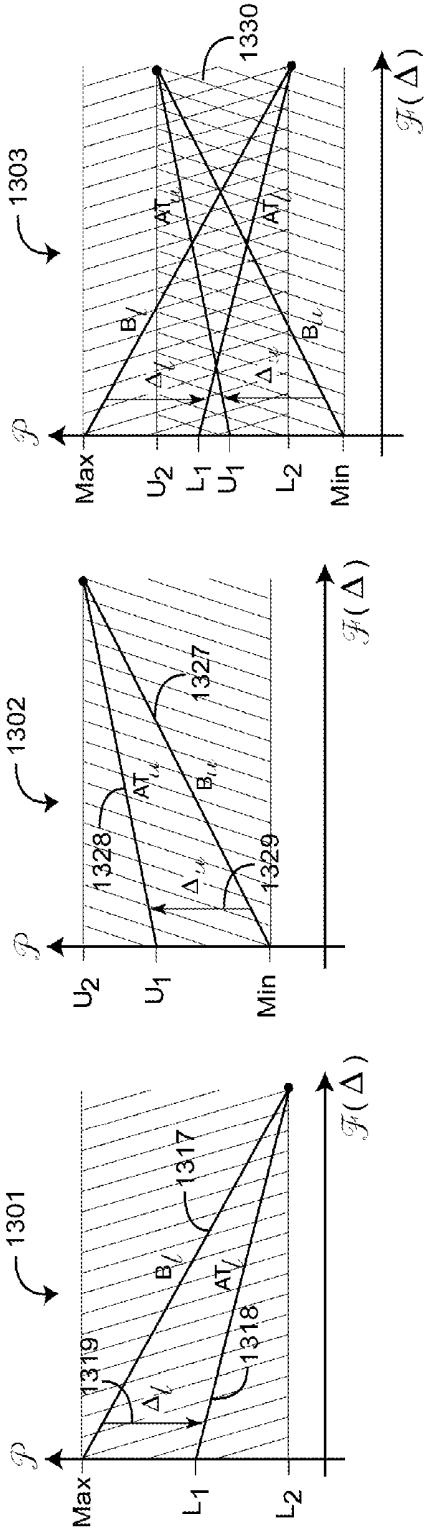

FIG. 13A

FIG. 13B

FIG. 13C

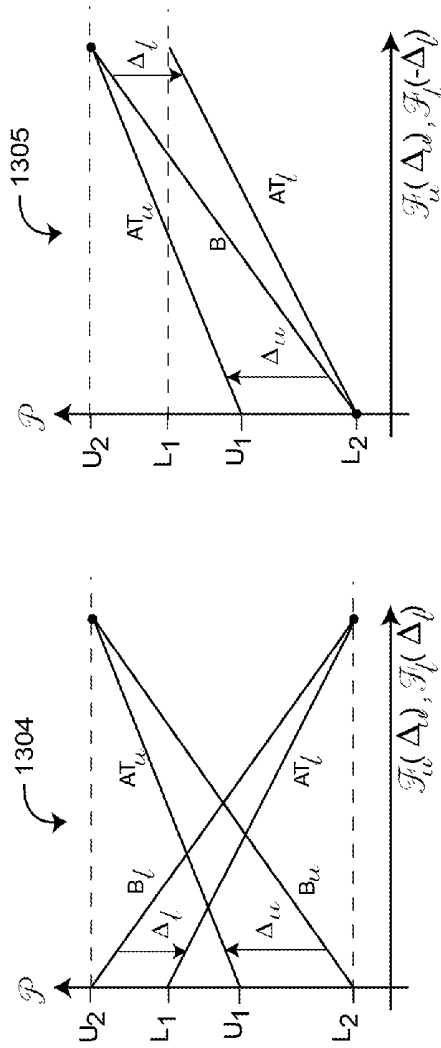

FIG. 13D

FIG. 13E

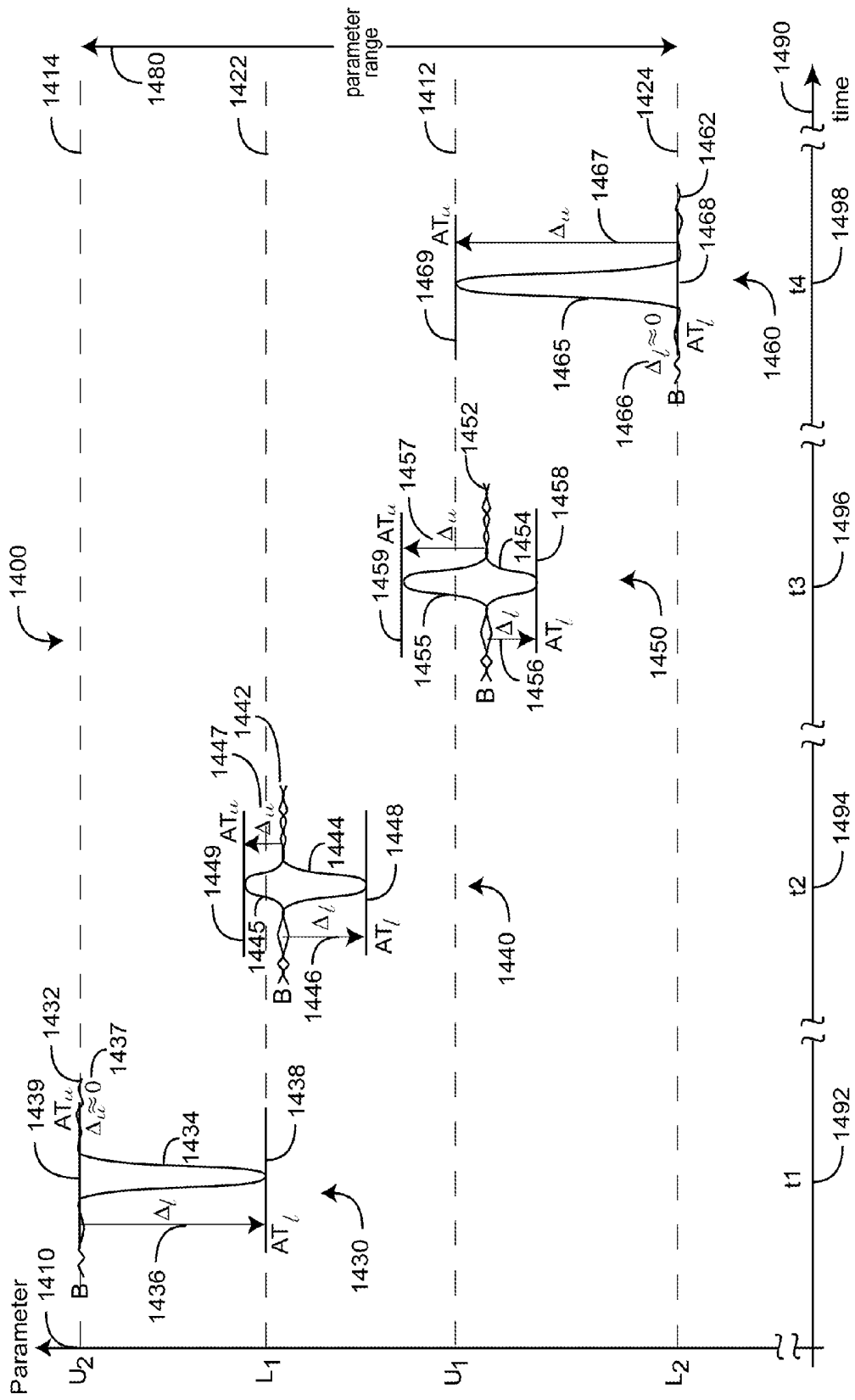

FIG. 14

ADAPTIVE ALARM SYSTEM

PRIORITY CLAIM TO RELATED PROVISIONAL APPLICATIONS

[0001] The present application claims priority benefit under 35 U.S.C. §119(e) to U.S. patent application Ser. No. 13/037,184, filed Feb. 18, 2011 titled Adaptive Alarm System; Provisional Patent Application Ser. No. 61/309,419, filed Mar. 1, 2010 titled Adaptive Threshold Alarm System; and U.S. Provisional Patent Application Ser. No. 61/328,630, filed Apr. 27, 2010 titled Adaptive Alarm System; all of the above-cited provisional patent applications are hereby incorporated by reference herein.

BACKGROUND OF THE INVENTION

[0002] Pulse oximetry systems for measuring constituents of circulating blood have gained rapid acceptance in a wide variety of medical applications, including surgical wards, intensive care and neonatal units, general wards, home care, physical training, and virtually all types of monitoring scenarios. A pulse oximetry system generally includes an optical sensor applied to a patient, a monitor for processing sensor signals and displaying results and a patient cable electrically interconnecting the sensor and the monitor. A pulse oximetry sensor has light emitting diodes (LEDs), typically one emitting a red wavelength and one emitting an infrared (IR) wavelength, and a photodiode detector. The emitters and detector are typically attached to a finger, and the patient cable transmits drive signals to these emitters from the monitor. The emitters respond to the drive signals to transmit light into the fleshy fingertip tissue. The detector generates a signal responsive to the emitted light after attenuation by pulsatile blood flow within the fingertip. The patient cable transmits the detector signal to the monitor, which processes the signal to provide a numerical readout of physiological parameters such as oxygen saturation (SpO_2) and pulse rate.

SUMMARY OF THE INVENTION

[0003] Conventional pulse oximetry assumes that arterial blood is the only pulsatile blood flow in the measurement site. During patient motion, venous blood also moves, which causes errors in conventional pulse oximetry. Advanced pulse oximetry processes the venous blood signal so as to report true arterial oxygen saturation and pulse rate under conditions of patient movement. Advanced pulse oximetry also functions under conditions of low perfusion (small signal amplitude), intense ambient light (artificial or sunlight) and electrosurgical instrument interference, which are scenarios where conventional pulse oximetry tends to fail.

[0004] Advanced pulse oximetry is described in at least U.S. Pat. Nos. 6,770,028; 6,658,276; 6,157,850; 6,002,952; 5,769,785 and 5,758,644, which are assigned to Masimo Corporation (“Masimo”) of Irvine, Calif. and are incorporated by reference herein. Corresponding low noise optical sensors are disclosed in at least U.S. Pat. Nos. 6,985,764; 6,813,511; 6,792,300; 6,256,523; 6,088,607; 5,782,757 and 5,638,818, which are also assigned to Masimo and are also incorporated by reference herein. Advanced pulse oximetry systems including Masimo SET® low noise optical sensors and read through motion pulse oximetry monitors for measuring SpO_2 , pulse rate (PR) and perfusion index (PI) are available from Masimo. Optical sensors include any of

Masimo LNOP®, LNCS®, SofTouch™ and Blue™ adhesive or reusable sensors. Pulse oximetry monitors include any of Masimo Rad-8®, Rad-5®, Rad®-5v or SatShare® monitors.

[0005] Advanced blood parameter measurement systems are described in at least U.S. Pat. No. 7,647,083, filed Mar. 1, 2006, titled Multiple Wavelength Sensor Equalization; U.S. Pat. No. 7,729,733, filed Mar. 1, 2006, titled Configurable Physiological Measurement System; U.S. Pat. Pub. No. 2006/0211925, filed Mar. 1, 2006, titled Physiological Parameter Confidence Measure and U.S. Pat. Pub. No. 2006/0238358, filed Mar. 1, 2006, titled Noninvasive Multi-Parameter Patient Monitor, all assigned to Masimo Laboratories, Irvine, Calif. (Masimo Labs) and all incorporated by reference herein. An advanced parameter measurement system that includes acoustic monitoring is described in U.S. Pat. Pub. No. 2010/0274099, filed Dec. 21, 2009, titled Acoustic Sensor Assembly, assigned to Masimo and incorporated by reference herein.

[0006] Advanced blood parameter measurement systems include Masimo Rainbow® SET, which provides measurements in addition to SpO_2 , such as total hemoglobin (SpHb™), oxygen content (SpOC™), methemoglobin (SpMet®), carboxyhemoglobin (SpCO®) and PVI®. Advanced blood parameter sensors include Masimo Rainbow® adhesive, ReSposable™ and reusable sensors. Advanced blood parameter monitors include Masimo Radical-7™, Rad-87™ and Rad-57™ monitors, all available from Masimo. Advanced parameter measurement systems may also include acoustic monitoring such as acoustic respiration rate (RRa™) using a Rainbow Acoustic Sensor™ and Rad-87™ monitor, available from Masimo. Such advanced pulse oximeters, low noise sensors and advanced physiological parameter measurement systems have also gained rapid acceptance in a wide variety of medical applications, including surgical wards, intensive care and neonatal units, general wards, home care, physical training, and virtually all types of monitoring scenarios.

[0007] FIGS. 1-3 illustrate problems and issues associated with physiological parameter measurement systems having fixed threshold alarm schemas. FIG. 1 illustrates a lower-limit, fixed-threshold alarm schema with respect to an oxygen saturation (SpO_2) parameter. Two alarm thresholds, D_L (delay) and ND_L (no delay), are defined. If oxygen saturation falls below D_L for a time delay greater than TD, an alarm is triggered. If oxygen saturation falls below ND_L an alarm is immediately triggered. D_L 120 is typically set around or somewhat above 90% oxygen saturation and ND_L 130 is typically set at 5% to 10% below D_L . For example, say a person's oxygen saturation 110 drops below D_L 120 at $t=t_1$ 162 and stays below D_L for at least a time delay TD 163. This triggers a delayed alarm 140 at $t=t_2$ 164, where $t_2=t_1+TD$. The alarm 140 remains active until oxygen saturation 110 rises above D_L 120 at $t=t_3$ 166. As another example, say that oxygen saturation 110 then drops below ND_L 130, which triggers an immediate alarm 150 at $t=t_4$ 168. The alarm 150 remains active until oxygen saturation 110 rises above D_L 120 at $t=t_5$ 169.

[0008] FIG. 2 illustrates an upper-limit, fixed-threshold alarm schema with respect to an oxygen saturation (SpO_2) parameter. This alarm scenario is particularly applicable to the avoidance of ROP (retinopathy of prematurity). Again, two alarm thresholds, D_U (delay) and ND_U (no delay), are defined. D_U 220 might be set at or around 85% oxygen

saturation and ND_U 230 might be set at or around 90% oxygen saturation. For example, a neonate's oxygen saturation 210 rises above D_U 220 at $t=t_1$ 262 and stays above D_U for at least a time delay TD 263. This triggers a delayed alarm 240 at $t=t_2$ 264, where $t_2=t_1+TD$. The alarm 240 remains active until oxygen saturation 210 falls below D_U 220 at $t=t_3$ 166. Oxygen saturation 210 then rises above ND_U 230, which triggers an immediate alarm 250 at $t=t_4$ 268. The alarm 250 remains active until oxygen saturation 210 falls below D_U 220 at $t=t_5$ 269.

[0009] FIG. 3 illustrates a baseline drift problem with the fixed threshold alarm schema described above. A person's oxygen saturation is plotted on an oxygen saturation (SpO_2) versus time graph 300. In particular, during a first time interval T_1 362, a person has an oxygen saturation 310 with a relatively stable "baseline" 312 punctuated by a shallow, transient desaturation event 314. This scenario may occur after the person has been on oxygen so that baseline oxygen saturation is near 100%. Accordingly, with a fixed threshold alarm 330 set at, say, 90%, the transient event 314 does not trigger a nuisance alarm. However, the effects of oxygen treatments wear off over time and oxygen saturation levels drift downward 350. In particular, during a second time interval T_2 364, a person has an oxygen saturation 320 with a relatively stable baseline 322. The later baseline 322 is established at a substantially lower oxygen saturation than the earlier baseline 312. In this scenario, a shallow, transient desaturation event 324 now exceeds the alarm threshold 330 and results in a nuisance alarm. After many such nuisance alarms, a caregiver may lower the alarm threshold 330 to unsafe levels or turn off alarms altogether, significantly hampering the effectiveness of monitoring oxygen saturation.

[0010] A fixed threshold alarm schema is described above with respect to an oxygen saturation parameter, such as derived from a pulse oximeter. However, problematic fixed threshold alarm behavior may be exhibited in a variety of parameter measurement systems that calculate physiological parameters related to circulatory, respiratory, neurological, gastrointestinal, urinary, immune, musculoskeletal, endocrine or reproductive systems, such as the circulatory and respiratory parameters cited above, as but a few examples.

[0011] An adaptive alarm system, as described in detail below, advantageously provides an adaptive threshold alarm to solve false alarm and missed true alarm problems associated with baseline drift among other issues. For example, for a lower limit embodiment, an adaptive alarm system adjusts an alarm threshold downwards when a parameter baseline is established at lower values. Likewise, for an upper limit embodiment, the adaptive alarm system adjusts an alarm threshold upwards in accordance with baseline drift so as to avoid nuisance alarms. In an embodiment, the rate of baseline movement is limited so as to avoid masking of transients. In an embodiment, the baseline is established along upper or lower portions of a parameter envelope so as to provide a margin of safety in lower limit or upper limit systems, respectively.

[0012] One aspect of an adaptive alarm system is responsive to a physiological parameter so as to generate an alarm threshold that adapts to baseline drift in the parameter and reduce false alarms without a corresponding increase in missed true alarms. The adaptive alarm system has a parameter derived from a physiological measurement system using a sensor in communication with a living being. A baseline

processor calculates a parameter baseline from an average value of the parameter. Parameter limits specify an allowable range of the parameter. An adaptive threshold processor calculates an adaptive threshold from the parameter baseline and the parameter limits. An alarm generator is responsive to the parameter and the adaptive threshold so as to trigger an alarm indicative of the parameter crossing the adaptive threshold. The adaptive threshold is responsive to the parameter baseline so as to increase in value as the parameter baseline drifts to a higher parameter value and to decrease in value as the parameter baseline drifts to a lower parameter value.

[0013] In various embodiments, the baseline processor has a sliding window that identifies a time slice of parameter values. A trend calculator determines a trend from an average of the parameter values in the time slice. A response limiter tracks only the relatively long-term transitions of the trend. A bias calculator deletes the highest parameter values in the time slice or the lowest parameter values in the time slice so as to adjust the baseline to either a lower value or a higher value, respectively. The adaptive threshold becomes less responsive to baseline drift as the baseline approaches a predefined parameter limit. A first adaptive threshold is responsive to lower parameter limits and a second adaptive threshold is responsive to upper parameter limits. The alarm generator is responsive to both positive and negative transients from the baseline according to the first adaptive threshold and the second adaptive threshold. The first adaptive threshold is increasingly responsive to negative transients and the second adaptive threshold is decreasingly responsive to positive transients as the baseline trends toward lower parameter values.

[0014] Another aspect of an adaptive alarm system measures a physiological parameter, establishes a baseline for the parameter, adjusts an alarm threshold according to drift of the baseline and triggers an alarm in response to the parameter measurement crossing the alarm threshold. In various embodiments, the baseline is established by biasing a segment of the parameter, calculating a biased trend from the biased segment and restricting the transient response of the biased trend. The alarm threshold is adjusted by setting a parameter limit and calculating a delta difference between the alarm threshold and the baseline as a linear function of the baseline according to the parameter limit. The delta difference is calculated by decreasing delta as the baseline drifts toward the parameter limit and increasing delta as the baseline drifts away from the parameter limit. A parameter limit is set by selecting a first parameter limit in relation to a delayed alarm and selecting a second parameter limit in relation to an un-delayed alarm. A segment of the parameter is biased by windowing the parameter measurements, removing a lower value portion of the windowed parameter measurements and averaging a remaining portion of the windowed parameter measurements. An upper delta difference between an upper alarm threshold and the baseline is calculated and a lower delta difference between a lower alarm threshold and the baseline is calculated.

[0015] A further aspect of an adaptive alarm system has a baseline processor that inputs a parameter and outputs a baseline according to a trend of the parameter. An adaptive threshold processor establishes an alarm threshold at a delta difference from the baseline. An alarm generator triggers an alarm based upon a parameter transient from the baseline crossing the alarm threshold. In various embodiments, a

trend calculator outputs a biased trend and the baseline is responsive to the biased trend so as to reduce the size of a transient that triggers the alarm. A response limiter reduces baseline movement due to parameter transients. The adaptive threshold processor establishes a lower alarm threshold below the baseline and an upper alarm threshold above the baseline so that the alarm generator is responsive to both positive and negative transients from the baseline. The baseline processor establishes a lower baseline biased above the parameter trend and an upper baseline biased below the parameter trend. The lower alarm threshold is increasingly responsive to negative transients and the upper alarm threshold is decreasingly responsive to positive transients as the baseline trends toward lower parameter values.

DESCRIPTION OF THE DRAWINGS

[0016] FIGS. 1-3 are exemplar graphs illustrating problems and issues associated with physiological parameter measurement systems having fixed threshold alarm schemas;

[0017] FIGS. 4A-B are general block diagrams of an adaptive alarm system having lower parameter limits;

[0018] FIGS. 5A-B are a graph of a physiological parameter versus delta space and a graph of delta versus baseline, respectively, illustrating the relationship between a baseline, a lower-limit adaptive threshold and a variable difference delta between the baseline and the adaptive threshold;

[0019] FIG. 6 is an exemplar graph of a physiological parameter versus time illustrating an adaptive alarm system having a lower-limit adaptive threshold;

[0020] FIG. 7 is a graph of oxygen saturation versus time illustrating a baseline for determining an adaptive threshold;

[0021] FIG. 8 is a graph of oxygen saturation versus time comparing adaptive-threshold alarm performance with fixed-threshold alarm performance;

[0022] FIGS. 9A-B are general block diagrams of an adaptive alarm system having upper parameter limits;

[0023] FIGS. 10A-B are a graph of a physiological parameter versus delta space and a graph of delta versus baseline, respectively, illustrating the relationship between a baseline, an upper-limit adaptive threshold and a variable delta difference between the baseline and the adaptive threshold;

[0024] FIG. 11 is an exemplar graph of a physiological parameter versus time illustrating an adaptive alarm system having an upper-limit adaptive threshold;

[0025] FIGS. 12A-B are general block diagrams of an adaptive alarm system having both lower alarm limits and upper alarm limits;

[0026] FIGS. 13A-E are physiological parameter versus delta space graphs illustrating a lower-limit adaptive threshold, an upper-limit adaptive threshold, and a combined lower- and upper-limit adaptive threshold in various delta spaces; and

[0027] FIG. 14 is an exemplar graph of a physiological parameter versus time illustrating an adaptive alarm system having both lower and upper alarm limits.

DETAILED DESCRIPTION OF THE PREFERRED EMBODIMENTS

[0028] FIGS. 4A-B illustrate an adaptive alarm system 400 embodiment having lower parameter limits L_1 and L_2 . As shown in FIG. 4A, the adaptive alarm system 400 has parameter 401, first limit (L_1) 403, second limit (L_2) 405 and

maximum parameter value (Max) 406 inputs and generates a corresponding alarm 412 output. The parameter 401 input is generated by a physiological parameter processor, such as a pulse oximeter or an advanced blood parameter processor described above, as examples. The adaptive alarm system 400 has an alarm generator 410, a baseline processor 420, and an adaptive threshold processor 440. The alarm generator 410 has parameter 401 and adaptive threshold (AT) 442 inputs and generates the alarm 412 output accordingly. A baseline processor 420 has the parameter 401 input and generates a parameter baseline (B) 422 output. The baseline processor 420, is described in detail with respect to FIG. 4B, below. An adaptive threshold processor 440 has parameter baseline (B) 422, L_1 403, L_2 405 and Max 406 inputs and generates the adaptive threshold (AT) 442. The adaptive threshold processor 440 is described in detail with respect to FIGS. 5A-B, below.

[0029] As shown in FIG. 4A, in an embodiment L_1 403 and L_2 405 may correspond to conventional fixed alarm thresholds with and without an alarm time delay, respectively. For an adaptive threshold schema, however, L_1 403 and L_2 405 do not determine an alarm threshold per se, but are reference levels for determining an adaptive threshold (AT) 442. In an embodiment, L_1 403 is an upper limit of the adaptive alarm threshold AT when the baseline is near the maximum parameter value (Max), and L_2 405 is a lower limit of the adaptive alarm threshold, as described in detail with respect to FIGS. 5A-B, below. In an exemplar embodiment when the parameter is oxygen saturation, L_1 403 is set at or around 90% and L_2 405 is set at 5 to 10% below L_1 , i.e. at 85% to 80% oxygen saturation. Many other L_1 and L_2 values may be used for an adaptive threshold schema as described herein.

[0030] Also shown in FIG. 4A, in an embodiment the alarm 412 output is triggered when the parameter 401 input falls below AT 442 and ends when the parameter 401 input rises above AT 442 or is otherwise cancelled. In an embodiment, the alarm 412 output is triggered after a time delay (TD), which may be fixed or variable. In an embodiment, the time delay (TD) is a function of the adaptive threshold (AT) 442. In an embodiment, the time delay (TD) is zero when the adaptive threshold (AT) is at the second lower limit (L_2) 405.

[0031] As shown in FIG. 4B, a baseline processor 420 embodiment has a sliding window 450, a bias calculator 460, a trend calculator 470 and a response limiter 480. The sliding window 450 inputs the parameter 401 and outputs a time segment 452 of the parameter 401. In an embodiment, each window incorporates a five minute span of parameter values. The bias calculator 460 advantageously provides an upward shift in the baseline (B) 422 for an additional margin of error over missed true alarms. That is, a baseline 422 is generated that tracks a higher-than-average range of parameter values, effectively raising the adaptive threshold AT slightly above a threshold calculated based upon a true parameter average, as shown and described in detail with respect to FIGS. 7-8, below. In an embodiment, the bias calculator 460 rejects a lower range of parameter values from each time segment 452 from the sliding window so as to generate a biased time segment 462.

[0032] Also shown in FIG. 4B, the trend calculator 470 outputs a biased trend 472 of the remaining higher range of parameter values in each biased segment 462. In an embodiment, the biased trend 462 is an average of the values in the biased time segment 462. In other embodiments, the biased

trend **462** is a median or mode of the values in the biased time segment **462**. The response limiter **480** advantageously limits the extent to which the baseline **422** output tracks the biased trend **472**. Accordingly, the baseline **422** tracks only relatively longer-lived transitions of the parameter, but does not track (and hence mask) physiologically significant parameter events, such as oxygen desaturations for a SpO₂ parameter to name but one example. In an embodiment, the response limiter **480** has a low pass transfer function. In an embodiment, the response limiter **480** is a slew rate limiter. [0033] FIGS. 5A-B further illustrate an adaptive threshold processor **440** (FIG. 4A) having a baseline (B) **422** input and generating an adaptive threshold (AT) **442** output and a delta (Δ) **444** ancillary output according to parameter limits L_1 **403**, L_2 **405** and Max **406**, as described above. As shown in FIG. 5A, as the baseline (B) **422** decreases (increases) the adaptive threshold (AT) **444** monotonically decreases (increases) between L_1 **403** and L_2 **405**. Further, as the baseline (B) **422** decreases (increases) the delta (Δ) **444** difference between the baseline (B) **422** and the adaptive threshold (AT) **442** monotonically decreases (increases) between $\text{Max}-L_1$ and zero.

[0034] As shown in FIG. 5B, the relationship between the delta (Δ) **444** and the baseline (B) **444** may be linear **550** (solid line), non-linear **560** (small-dash lines) or piecewise-linear (large-dash lines), to name a few. In an embodiment, the adaptive threshold processor **440** (FIG. 4A) calculates an adaptive threshold (AT) **442** output in response to the baseline (B) **422** input according to a linear relationship. In a linear embodiment, the adaptive threshold processor **440** (FIG. 4A) calculates the adaptive threshold (AT) **442** according to EQS. 1-2:

$$\Delta = -\left(\frac{\text{Max} - L_1}{\text{Max} - L_2}\right)(\text{Max} - B) + (\text{Max} - L_1) \quad (1)$$

$$AT = B - \Delta \quad (2)$$

where $\Delta = \text{Max} - L_1$ @ $B = \text{Max}$; $\Delta = 0$ @ $B = L_2$
and where $AT = L_1$ @ $B = \text{Max}$; $AT = L_2$ @ $B = L_2$, accordingly.

[0035] FIG. 6 illustrates the operational characteristics an adaptive alarm system **400** (FIG. 4A) having parameter limits Max **612**, L_1 **614** and L_2 **616** and an alarm responsive to a baseline (B) **622**, **632**, **642**; an adaptive threshold (AT) **628**, **638**, **648**; and a corresponding Δ **626**, **636**, **646** according to EQS. 1-2, above. In particular, a physiological parameter **610** is graphed versus time **690** for various time segments t_1 , t_2 , t_3 **692-696**. The parameter range (PR) **650** is:

$$\text{PR} = \text{Max} - L_2 \quad (3)$$

and the adaptive threshold range (ATR) **660** is:

$$\text{ATR} = L_1 - L_2 \quad (4)$$

[0036] As shown in FIG. 6, during a first time period t_1 **692**, a parameter segment **620** has a baseline (B) **622** at about Max **612**. As such, Δ **626** = $\text{Max} - L_1$ and the adaptive threshold (AT) **628** is at about L_1 **614**. Accordingly, a transient **624** having a size less than Δ **626** does not trigger the alarm **412** (FIG. 4A).

[0037] Also shown in FIG. 6, during a second time period t_2 **694**, a parameter segment **630** has a baseline (B) **632** at about L_1 **614**. As such, Δ **636** is less than $\text{Max} - L_1$ and the adaptive threshold (AT) **638** is between L_1 and L_2 . Accord-

ingly, a smaller transient **634** will trigger the alarm as compared to a transient **624** in the first time segment.

[0038] Further shown in FIG. 6, during a third time period t_3 **696**, a parameter segment **640** has a baseline (B) **642** at about L_2 **616**. As such, Δ **646** is about zero and the adaptive threshold (AT) **648** is at about L_2 . Accordingly, even a small negative transient will trigger the alarm. As such, the behavior of the alarm threshold AT **628**, **638**, **648** advantageously adapts to higher or lower baseline values so as to increase or decrease the size of negative transients that trigger or do not trigger the alarm **412** (FIG. 4A).

[0039] FIG. 7 is a parameter versus time graph **700** illustrating the characteristics of an adaptive alarm system **400** (FIGS. 4A-B), as described with respect to FIGS. 4-6, above, where the parameter is oxygen saturation (SpO₂). The graph **700** has a SpO₂ trace **710** and a superimposed baseline trace **720**. The graph **700** also delineates tracking periods **730**, where the baseline **720** follows the upper portions of SpO₂ values, and lagging periods **740**, where the baseline **720** does not follow transient SpO₂ events. The tracking time periods **730** illustrate that the baseline **720** advantageously tracks at the higher range of SpO₂ values **710** during relatively stable (flat) periods, as described above. Lagging time periods **740** illustrate that the baseline **720** is advantageously limited in response to transient desaturation events so that significant desaturations fall below an adaptive threshold (not shown) and trigger an alarm accordingly.

[0040] FIG. 8 is a parameter versus time graph **800** illustrating characteristics of an adaptive alarm system **400** (FIGS. 4A-B), as described with respect to FIGS. 4-6, above, where the parameter is oxygen saturation (SpO₂). Vertical axis (SpO₂) resolution is 1%. The time interval **801** between vertical hash marks is five minutes. The graph **800** has a SpO₂ trace **810** and a baseline trace **820**. The graph **800** also has a fixed threshold trace **830**, a first adaptive threshold (AT) trace **840** and a second AT trace **850**. The graph **800** further has a fixed threshold alarm trace **860**, a first adaptive threshold alarm trace **870** and a second adaptive threshold alarm trace **880**. In this example, L_1 is 90% and L_2 is 85% for the first AT trace **840** and first AT alarm trace **870**. L_2 is 80% for a second AT trace **850** and a second AT alarm trace **880**. The fixed threshold **830** results in many nuisance alarms **860**. By comparison, the adaptive threshold alarm with $L_2 = 85\%$ has just one time interval of alarms **872** during a roughly 6% desaturation period (from 92% to 86%). The adaptive threshold alarm with $L_2 = 80\%$, has no alarms during the 1 hour 25 minute monitoring period.

[0041] FIGS. 9A-B illustrate an adaptive alarm system **900** embodiment having upper parameter limits U_1 and U_2 . As shown in FIG. 9A, the adaptive alarm system **900** has parameter **901**, first limit (U_1) **903**, second limit (U_2) **905** and minimum parameter value (Min) **906** inputs and generates a corresponding alarm **912** output. The parameter **901** input is generated by a physiological parameter processor, such as a pulse oximeter or an advanced blood parameter processor described above, as examples. The adaptive alarm system **900** has an alarm generator **910**, a baseline processor **920**, and an adaptive threshold processor **940**. The alarm generator **910** has parameter **901** and adaptive threshold (AT) **942** inputs and generates the alarm **912** output accordingly. A baseline processor **920** has the parameter **901** input and generates a parameter baseline (B) **922** output. The baseline processor **920**, is described in detail with respect to

FIG. 9B, below. An adaptive threshold processor 940 has parameter baseline (B) 922, U_1 903, U_2 905 and Min 906 inputs and generates the adaptive threshold (AT) 942. The adaptive threshold processor 940 is described in detail with respect to FIGS. 10A-B, below.

[0042] As shown in FIG. 9A, in an embodiment U_1 903 and U_2 905 may correspond to conventional fixed alarm thresholds with and without an alarm time delay, respectively. For an adaptive threshold schema, however, U_1 903 and U_2 905 do not determine an alarm threshold per se, but are reference levels for determining an adaptive threshold (AT) 942. In an embodiment, U_1 903 is a lower limit of the adaptive alarm threshold AT when the baseline is near the minimum parameter value (Min), and U_2 905 is an upper limit of the adaptive alarm threshold, as described in detail with respect to FIGS. 10A-B, below. In an exemplar embodiment when the parameter is oxygen saturation, U_1 903 is set at or around 85% and U_2 905 is set at or around 90% oxygen saturation. Many other U_1 and U_2 values may be used for an adaptive threshold schema as described herein.

[0043] Also shown in FIG. 9A, in an embodiment the alarm 912 output is triggered when the parameter 901 input rises above AT 942 and ends when the parameter 901 input falls below AT 942 or is otherwise cancelled. In an embodiment, the alarm 912 output is triggered after a time delay (TD), which may be fixed or variable. In an embodiment, the time delay (TD) is a function of the adaptive threshold (AT) 942. In an embodiment, the time delay (TD) is zero when the adaptive threshold (AT) is at the second upper limit (U_2) 905.

[0044] As shown in FIG. 9B, a baseline processor 920 embodiment has a sliding window 950, a bias calculator 960, a trend calculator 970 and a response limiter 980. The sliding window 950 inputs the parameter 901 and outputs a time segment 952 of the parameter 901. In an embodiment, each window incorporates a five minute span of parameter values. The bias calculator 960 advantageously provides a downward shift in the baseline (B) 922 for an additional margin of error over missed true alarms. That is, a baseline 922 is generated that tracks a lower-than-average range of parameter values, effectively lowering the adaptive threshold AT slightly below a threshold calculated based upon a true parameter average. In an embodiment, the bias calculator 960 rejects an upper range of parameter values from each time segment 952 from the sliding window so as to generate a biased time segment 962.

[0045] Also shown in FIG. 9B, the trend calculator 970 outputs a biased trend 972 of the remaining lower range of parameter values in each biased segment 962. In an embodiment, the biased trend 962 is an average of the values in the biased time segment 962. In other embodiments, the biased trend 962 is a median or mode of the values in the biased time segment 962. The response limiter 980 advantageously limits the extent to which the baseline 922 output tracks the biased trend 972. Accordingly, the baseline 922 tracks only relatively longer-lived transitions of the parameter, but does not track (and hence mask) physiologically significant parameter events, such as oxygen desaturations for a SpO_2 parameter to name but one example. In an embodiment, the response limiter 980 has a low pass transfer function. In an embodiment, the response limiter 980 is a slew rate limiter.

[0046] FIGS. 10A-B further illustrate an adaptive threshold processor 940 (FIG. 9A) having a baseline (B) 922 input

and generating an adaptive threshold (AT) 942 output and a delta (Δ) 944 ancillary output according to parameter limits U_1 903, U_2 905 and Min 906, as described above. As shown in FIG. 10A, as the baseline (B) 922 decreases (increases) the adaptive threshold (AT) 944 monotonically decreases (increases) between U_1 903 and U_2 905. Further, as the baseline (B) 922 decreases (increases) the delta (Δ) 944 difference between the baseline (B) 922 and the adaptive threshold (AT) 942 monotonically decreases (increases) between Min- U_1 and zero.

[0047] As shown in FIG. 10B, the relationship between the delta (Δ) 944 and the baseline (B) 944 may be linear 550 (solid line), non-linear 560 (small-dash lines) or piecewise-linear (large-dash lines), to name a few. In an embodiment, the adaptive threshold processor 940 (FIG. 9A) calculates an adaptive threshold (AT) 942 output in response to the baseline (B) 922 input according to a linear relationship. In a linear embodiment, the adaptive threshold processor 940 (FIG. 9A) calculates the adaptive threshold (AT) 942 according to EQS. 5-6:

$$\Delta = -\left(\frac{U_1 - \text{Min}}{U_2 - \text{Min}}\right)(B - \text{Min}) + (U_1 - \text{Min}) \quad (5)$$

$$AT = B + \Delta \quad (6)$$

where $\Delta = U_1 - \text{Min}$ @ $B = \text{Min}$; $\Delta = 0$ @ $B = U_2$
and where $AT = U_1$ @ $B = \text{Min}$; $AT = U_2$ @ $B = U_2$, accordingly.
[0048] FIG. 11 illustrates the operational characteristics an adaptive alarm system 900 (FIG. 9A) having parameter limits Min 1112, U_1 1114 and U_2 1116 and an alarm responsive to a baseline (B) 1122, 1132, 1142; an adaptive threshold (AT) 1128, 1138, 1148; and a corresponding Δ 1126, 1136, 1146 according to EQS. 5-6, above. In particular, a physiological parameter 1110 is graphed versus time 1190 for various time segments t_1 , t_2 , t_3 1192-1196. The parameter range (PR) 1150 is:

$$PR = U_2 - \text{Min} \quad (7)$$

and the adaptive threshold range (ATR) 1160 is:

$$ATR = U_2 - U_1 \quad (8)$$

[0049] As shown in FIG. 11, during a first time period t_1 1192, a parameter segment 1120 has a baseline (B) 1122 at about Min 1112. As such, Δ 1126 = $U_1 - \text{Min}$ and the adaptive threshold (AT) 1128 is at about U_1 1114. Accordingly, a transient 1124 having a size less than Δ 1126 does not trigger the alarm 912 (FIG. 9A).

[0050] Also shown in FIG. 11, during a second time period t_2 1194, a parameter segment 1130 has a baseline (B) 1132 at about U_1 1114. As such, Δ 1136 is less than $U_1 - \text{Min}$ and the adaptive threshold (AT) 1138 is between U_1 and U_2 . Accordingly, a smaller transient 1134 will trigger the alarm as compared to a transient 1124 in the first time segment.

[0051] Further shown in FIG. 11, during a third time period t_3 1196, a parameter segment 1140 has a baseline (B) 1142 at about U_2 1116. As such, Δ 1146 is about zero and the adaptive threshold (AT) 1148 is at about U_2 . Accordingly, even a small positive transient will trigger the alarm. As such, the behavior of the alarm threshold AT 1128, 1138, 1148 advantageously adapts to higher or lower baseline values so as to increase or decrease the size of positive transients that trigger or do not trigger the alarm 912 (FIG. 9A).

[0052] FIGS. 12A-B illustrate an adaptive alarm system 1200 embodiment having lower limits L_1, L_2 1203, such as described with respect to FIGS. 4A-B above, or upper limits U_1, U_2 1205 such as described with respect to FIGS. 9A-B above, or both. As shown in FIG. 12A, the adaptive alarm system 1200 has parameter 1201, lower limit 1203 and upper limit 1205 inputs and generates a corresponding alarm 1212 output. The parameter 1201 input is generated by a physiological parameter processor, such as a pulse oximeter or an advanced blood parameter processor described above, as examples. The adaptive alarm system 1200 has an alarm generator 1210, a baseline processor 1220 and an adaptive threshold processor 1240. The alarm generator 1210 has parameter 1201 and adaptive threshold (AT) 1242 inputs and generates the alarm 1212 output accordingly. A baseline processor 1220 has the parameter 1201 input and generates one or more parameter baseline 1222 outputs. The baseline processor 1220, is described in detail with respect to FIG. 12B, below. An adaptive threshold processor 1240 has parameter baseline 1222, lower limit L_1, L_2 1203 and upper limit U_1, U_2 1205 inputs and generates lower and upper adaptive threshold AT_l, AT_u 1242 outputs. The adaptive threshold processor 1240 also generates ancillary upper and lower delta 1244 outputs. The adaptive threshold processor 1240 is described in detail with respect to FIGS. 13A-E, below.

[0053] As shown in FIG. 12A, in an embodiment L_1, L_2 1203 and U_1, U_2 1205 may correspond to conventional fixed alarm thresholds with an alarm delay (L_1, U_1) and without an alarm delay (L_2, U_2). For an adaptive threshold schema, however, these limits 1203, 1205 do not determine an alarm threshold per se, but are reference levels for determining lower and upper adaptive thresholds AT_l, AT_u 1242.

[0054] Also shown in FIG. 12A, in an embodiment the alarm 1212 output is triggered when the parameter 1201 input falls below AT_l 1242 and ends when the parameter 1201 input rises above AT_l 1242 or the alarm is otherwise cancelled. Further, the alarm 1212 output is triggered when the parameter 1201 input rises above AT_u 1242 and ends when the parameter 1201 input falls below AT_u 1242 or the alarm is otherwise cancelled. In an embodiment, the alarm 1212 output is triggered after a time delay (TD), which may be fixed or variable. In an embodiment, the time delay (TD) is a function of the adaptive thresholds (AT_l, AT_u) 1242. In an embodiment, the time delay (TD) is zero when the lower adaptive threshold (AT_l) 1242 is at the second lower limit (L_2) 1203 or when the upper adaptive alarm threshold AT_u 1242 is at the second upper limit (U_2) 1205.

[0055] As shown in FIG. 12B, a baseline processor 1220 embodiment has a sliding window 1250, an over-bias calculator 1260, an under-bias calculator 1265, trend calculators 1270 and response limiters 1280. The sliding window 1250 inputs the parameter 1201 and outputs a time segment 1252 of the parameter 1201. In an embodiment, each window incorporates a five minute span of parameter 1201 values.

[0056] Also shown in FIG. 12B, the over-bias calculator 1260 advantageously provides an upward shift in the lower baseline (B_l) 1282 for an additional margin of error over missed lower true alarms. That is, a lower baseline (B_l) 1282 is generated that tracks a higher-than-average range of parameter values, effectively raising the lower adaptive threshold AT_l slightly above a threshold calculated based upon a true parameter average. In an embodiment, the

over-bias calculator 1260 rejects a lower range of parameter values from each time segment 1252 of the sliding window 1250 so as to generate an over-biased time segment 1262.

[0057] Further shown in FIG. 12B, the under-bias calculator 1265 advantageously provides a downward shift in the upper baseline (B_u) 1287 for an additional margin of error over missed upper true alarms. That is, an upper baseline (B_u) 1287 is generated that tracks a lower-than-average range of parameter values, effectively lowering the upper adaptive threshold AT_u slightly below a threshold calculated based upon a true parameter average. In an embodiment, the under-bias calculator 1267 rejects an upper range of parameter values from each time segment 1252 of the sliding window 1250 so as to generate an under-biased time segment 1267.

[0058] Additionally shown in FIG. 12B, the trend calculator 1270 outputs an over-biased trend 1272 of the remaining higher range of parameter values in each over-biased segment 1262. Further, the trend calculator 1270 outputs an under-biased trend 1277 of the remaining lower range of parameter values in each under-biased segment 1267. In an embodiment, the biased trends 1272, 1277 are each an average of the values in the corresponding biased time segments 1262, 1267. In other embodiments, the biased trends 1272, 1277 are each a median or mode of the values in the corresponding biased time segments 1262, 1267. The response limiter 1280 advantageously limits the extent to which the baseline 1222 outputs track the biased trends 1272, 1277. Accordingly, the baseline 1222 outputs track only relatively longer-lived transitions of the parameter 1201, but do not track (and hence mask) physiologically significant parameter events. In an embodiment, the response limiter 1280 has a low pass transfer function. In an embodiment, the response limiter 1280 is a slew rate limiter.

[0059] FIGS. 13A-E illustrate parameter (P) operating ranges and ideal ranges in view of both lower and upper parameter limits. As shown in FIG. 13A, as the baseline (B_l) 1317 decreases (increases) the adaptive threshold (AT_l) 1318 monotonically decreases (increases) between L_1 and L_2 . Further, as the baseline (B_l) 1317 decreases (increases) the delta (Δ_l) 1319 difference between the baseline (B_l) 1317 and the adaptive threshold (AT_l) 1318 monotonically decreases (increases) between $Max-L_1$ and 0.

[0060] As shown in FIG. 13B, as the baseline (B_u) 1327 increases (decreases) the adaptive threshold (AT_u) 1328 monotonically increases (decreases) between U_1 and U_2 . Further, as the baseline (B_u) 1327 increases (decreases) the delta (Δ_u) 1329 difference between the adaptive threshold (AT_u) 1328 and the baseline (B_u) 1327 monotonically decreases (increases) between $Min-U_1$ and 0.

[0061] As shown in FIG. 13C, combining FIGS. 13A-B, the parameter (P) operating range is bounded by the overlapping regions of 13A and 13B 1330 having an upper bound of U_2 and a lower bound of L_2 . In particular, L_1, L_2 are the upper and lower limits of the lower adaptive alarm threshold AT_l ; and U_2, U_1 are the upper and lower limits of the upper adaptive alarm threshold AT_u .

[0062] FIG. 13D illustrates parameter (P) versus the overlapping independent delta domains F_u, F_l for upper and lower baselines B_u, B_l ; adaptive thresholds AT_u, AT_l and deltas Δ_u, Δ_l , based upon FIGS. 13A-C. FIG. 13E illustrates parameter (P) versus the overlapping independent delta domains F_u, F_l (reversed); for upper and lower baselines B_u, B_l ; adaptive thresholds AT_u, AT_l and deltas Δ_u, Δ_l .

[0063] As shown in FIG. 13E, the equations for bi-lateral adaptive thresholds are:

$$\Delta_u = -\left(\frac{U_1 - L_2}{U_2 - L_2}\right)(B - L_2) + (U_1 - L_2) \quad (9)$$

$$AT_u = B + \Delta_u \quad (10)$$

where $\Delta_u = U_1 - L_2$ @ $B = L_2$; and $\Delta_u = 0$ @ $B = U_2$; and where $AT_u = U_1$ @ $B = L_2$; and $AT_u = U_2$ @ $B = U_2$.

Further:

[0064]

$$\Delta_l = \left(\frac{U_2 - L_1}{U_2 - L_2}\right)(B - L_2) \quad (11)$$

$$AT_l = B - \Delta_l \quad (12)$$

where $\Delta_l = U_2 - L_1$ @ $B = U_2$; and $\Delta_l = 0$ @ $B = L_2$; and where $AT_l = L_1$ @ $B = U_2$; $AT_l = L_2$ @ $B = L_2$.

[0065] Although shown as a linear relationship, in general:

$$\Delta_l = f_1(B); \Delta_u = f_2(B)$$

That is, Δ_l and Δ_u can each be a linear function of B, a non-linear function of B or a piecewise linear function of B, to name a few, in a manner similar to that described with respect to FIGS. 5B and 10B, above.

[0066] FIGS. 14A-B illustrate the operational characteristics an adaptive alarm system 1200 (FIGS. 12A-B) having upper limits U_1, U_2 1412, 1414 and lower limits L_1, L_2 1422, 1424. An alarm 1212 (FIG. 12A) output is responsive to a baseline (B) 1432, 1442, 1452, 1462; an upper delta (Δ_u) 1437, 1447, 1457, 1467; and a corresponding upper adaptive threshold (AT_u) 1439, 1449, 1459, 1469, according to EQS. 9-10, above. Further, the alarm 1212 (FIG. 12A) output is responsive to a lower delta (Δ_l) 1436, 1446, 1456, 1466 and a corresponding lower adaptive threshold (AT_l) 1438, 1448, 1458, 1468, according to EQS. 11-12, above.

[0067] As shown in FIGS. 14A-B, a physiological parameter 1410 is graphed versus time 1490 for various time segments t_1, t_2, t_3, t_4 1492-1498. The parameter range (PR) 1480 is:

$$PR = U_2 - L_2 \quad (13)$$

the lower adaptive threshold AT_l range is:

$$ATR_l = L_1 - L_2 \quad (14)$$

the upper adaptive threshold AT_u range is:

$$ATR_u = U_2 - U_1 \quad (15)$$

[0068] As shown in FIG. 14A, during a first time period t_1 1492, a parameter segment 1430 has a baseline (B) 1432 at about U_2 1414. As such, Δ_l 1436 = $U_2 - L_1$; Δ_u 1437 = 0; AT_l 1438 = L_1 ; AT_u 1439 = U_2 . Accordingly, a negative transient 1434 having a size less than $U_2 - L_1$ does not trigger an alarm.

[0069] Also shown in FIG. 14A, during a second time period t_2 1494, a parameter segment 1440 has a baseline (B) 1442 less than U_2 . As such, Δ_l 1446 is less than $U_1 - L_1$ and the adaptive threshold (AT_u) 1447 is between U_1 and U_2 . Accordingly, a smaller negative transient 1444 will trigger the alarm as compared to the negative transient 1434 in the first time segment 1430.

[0070] Further shown in FIG. 14A, during a third time period t_3 1496, a parameter segment 1450 has a baseline (B) 1452 less than U_1 1412. As such, a smaller negative transient 1454 will trigger the alarm as compared to the negative transient 1444 in the second time segment 1440. However, a larger positive transient 1455 is needed to trigger the alarm as compared to the positive transient 1445 in the second time segment 1440.

[0071] Additionally shown in FIG. 14A, during a fourth time period t_4 1460, a parameter segment 1460 has a baseline (B) 1462 at about L_2 1424. As such, Δ_l 1466 = 0; Δ_u 1467 = $U_1 - L_2$; AT_l 1468 = L_2 ; AT_u 1469 = U_1 . Accordingly, a positive transient 1465 having a size less than $U_1 - L_2$ does not trigger an alarm.

[0072] An adaptive alarm system has been disclosed in detail in connection with various embodiments. These embodiments are disclosed by way of examples only and are not to limit the scope of the claims that follow. One of ordinary skill in the art will appreciate many variations and modifications.

What is claimed is:

1. A system for reducing electronic alarms in a medical patient monitoring system, the system comprising:

an optical sensor configured to transmit optical radiation into a tissue site of a patient and detect attenuated optical radiation indicative of at least one physiological parameter of a patient; and

one or more hardware processors in electronic communication with the optical sensor, the one or more hardware processors configured to:

measure oxygen saturation values of a patient over a first period of time;

determine if at least one oxygen saturation value obtained over the first period of time exceeds a first alarm threshold;

determine whether a first alarm should be triggered based on the determination that the at least one oxygen saturation value obtained over the first period of time exceeds the first alarm threshold;

determine a second alarm threshold to be applied during a second period of time subsequent to the first period of time, the second alarm threshold replacing the first alarm threshold, the second alarm threshold being determined by:

comparing at least a first oxygen saturation value obtained during the first time period with a lower limit associated with oxygen saturation; and

computing a second alarm threshold based on the comparison where the second alarm threshold is computed to be at a value less than the at least first oxygen saturation value and greater than the lower limit and at an offset from the first oxygen saturation value, wherein the offset is configured to diminish as a difference between the at least first oxygen saturation value and the lower limit diminishes;

measure oxygen saturation values of a patient over the second period of time to determine at least a second oxygen saturation value; and

determine whether a second alarm should be triggered by determining if at least one oxygen saturation value obtained during the second period of time

exceeds the second alarm threshold and triggering an alarm if it is determined the second alarm should be triggered.

2. The system of claim 1, wherein the one or more hardware processors are configured to calculate a first baseline measurement from the measured oxygen saturation values over the first period of time and wherein the at least one oxygen saturation value obtained during the first period of time corresponds to the first baseline measurement.

3. The system of claim 2, wherein the one or more hardware processors are configured to calculate a second baseline measurement from the measured oxygen saturation values over the second period of time and wherein the at least one oxygen saturation value obtained during the second period of time corresponds to the second baseline measurement.

4. The system of claim 1, wherein the lower limit is predefined and corresponds to a minimum parameter value for oxygen saturation.

5. The system of claim 1, wherein the one or more hardware processors are further configured to wait for a time delay prior to the triggering of the second alarm, and wherein the time delay is a function of the second alarm threshold.

6. The system of claim 5, wherein the time delay decreases as the difference between the at least first oxygen saturation value and the lower limit diminishes.

7. The system of claim 1, wherein the first alarm threshold is predetermined.

8. A system for reducing electronic alarms in a medical patient monitoring system including a pulse oximeter in communication with an optical sensor, the system comprising one or more hardware processors configured to:

measure oxygen saturation values of a patient over a first period of time;

determine if at least one oxygen saturation value obtained over the first period of time exceeds a first alarm threshold;

determine whether a first alarm should be triggered based on the determination that the at least one oxygen saturation value obtained over the first period of time exceeds the first alarm threshold;

compare at least a first oxygen saturation value obtained during the first time period with a lower limit associated with oxygen saturation;

compute a second alarm threshold based on the comparison;

determine a time delay based on the computed second alarm threshold, wherein the time delay approaches zero as the first oxygen saturation value approaches the lower limit;

measure oxygen saturation values of a patient over the second period of time to determine at least a second oxygen saturation value; and

determine whether a second alarm should be triggered by determining if at least one oxygen saturation value obtained during the second period of time exceeds the second alarm threshold and triggering an alarm if it is determined the second alarm should be triggered.

9. The system of claim 8, wherein the first alarm threshold is predetermined.

10. The system of claim 8, wherein the lower limit is predefined and corresponds to a minimum parameter value for oxygen saturation.

11. The system of claim 8, where the second alarm threshold is computed to be at a value less than the at least first oxygen saturation value and greater than the lower limit and at an offset from the first oxygen saturation value, wherein the offset is configured to diminish as a difference between the at least first oxygen saturation value and the lower limit diminishes;

12. An electronic method for reducing electronic alarms in a medical patient monitoring system, the electronic method comprising:

measuring oxygen saturation values of a patient over a first period of time;

determining if at least one oxygen saturation value determined over the first period of time exceeds a first alarm threshold;

determining whether a first alarm should be triggered based on the determination that at least one oxygen saturation value obtained during the first period of time exceeds the first alarm threshold;

comparing at least a first oxygen saturation value obtained during the first time period with a lower limit associated with oxygen saturation;

computing the second alarm threshold based on the comparison where the second alarm threshold is computed to be at a value less than the at least first oxygen saturation value and greater than the lower limit and at an offset from the first oxygen saturation value, wherein the offset is configured to diminish as a difference between the at least first oxygen saturation value and the lower limit diminishes and wherein the second alarm threshold is configured to be applied during a second period of time subsequent to the first period of time, the second alarm threshold replacing the first alarm threshold;

measuring oxygen saturation values of a patient over the second period of time to determine at least a second oxygen saturation value; and

determining whether a second alarm should be triggered by determining if at least one oxygen saturation value obtained during the second period of time exceeds the second alarm threshold and triggering an alarm if it is determined the second alarm should be triggered.

13. The electronic method of claim 12, wherein the one or more hardware processors are configured to calculate a first baseline measurement from the measured oxygen saturation values over the first period of time and wherein the at least one oxygen saturation value obtained during the first period of time corresponds to the first baseline measurement.

14. The electronic method of claim 13, wherein the one or more hardware processors are configured to calculate a second baseline measurement from the measured oxygen saturation values over the second period of time and wherein the at least one oxygen saturation value obtained during the second period of time corresponds to the second baseline measurement.

15. The electronic method of claim 12, wherein the lower limit is predefined and corresponds to a minimum parameter value for oxygen saturation.

16. The electronic method of claim 12, wherein the one or more hardware processors are further configured to wait for a time delay prior to the triggering of the second alarm, and wherein the time delay is a function of the second alarm threshold.

17. The electronic method of claim 16, wherein the time delay decreases as the difference between the at least first oxygen saturation value and the lower limit diminishes.

18. The electronic method of claim 12, wherein the first alarm threshold is predetermined.

* * * * *

专利名称(译)	自适应报警系统		
公开(公告)号	US20170231537A1	公开(公告)日	2017-08-17
申请号	US15/583718	申请日	2017-05-01
[标]申请(专利权)人(译)	梅西莫股份有限公司		
申请(专利权)人(译)	Masimo公司		
当前申请(专利权)人(译)	Masimo公司		
[标]发明人	AL ALI AMMAR		
发明人	AL-ALI, AMMAR		
IPC分类号	A61B5/1455 G08B29/26 A61B5/00		
CPC分类号	A61B5/1455 A61B5/74 A61B5/14552 A61B5/746 A61B5/14551 A61B2560/0276 G08B29/26		
优先权	61/309419 2010-03-01 US 61/328630 2010-04-27 US		
其他公开文献	US9775570		
外部链接	Espacenet USPTO		

摘要(译)

用于减少医疗患者监测系统中的电子警报的系统 and 电子过程。例如，用于减少电子警报的系统可以包括光学传感器和与光学传感器电子通信的一个或多个硬件处理器。可以对一个或多个硬件处理器进行编程以在第一时间段内测量患者的氧饱和度值，确定在第一时间段内获得的至少一个氧饱和度值是否超过第一警报阈值，确定是否第一警报应该基于在第一时间段内获得的至少一个氧饱和度值超过第一警报阈值的确定来触发，确定在第一时间段之后的第二时间段期间应用的第二警报阈值，第二个告警阈值替换第一个告警阈值。

