



(19) **United States**  
(12) **Patent Application Publication**  
**Bardy et al.**

(10) **Pub. No.: US 2015/0087922 A1**  
(43) **Pub. Date: Mar. 26, 2015**

(54) **SELF-CONTAINED PERSONAL AIR FLOW SENSING MONITOR**

*A61B 5/145* (2006.01)  
*A61B 5/11* (2006.01)  
*A61B 5/1455* (2006.01)  
*A61B 5/00* (2006.01)

(71) Applicant: **Bardy Diagnostics, Inc.**, Vashon, WA (US)

(52) **U.S. Cl.**  
CPC ..... *A61B 5/02055* (2013.01); *A61B 5/14551* (2013.01); *A61B 5/04085* (2013.01); *A61B 5/04087* (2013.01); *A61B 5/04325* (2013.01); *A61B 5/6823* (2013.01); *A61B 5/7282* (2013.01); *A61B 5/01* (2013.01); *A61B 5/14532* (2013.01); *A61B 5/1118* (2013.01); *A61B 5/4818* (2013.01); *A61B 5/03* (2013.01); *A61B 5/087* (2013.01)  
USPC ..... **600/301**

(72) Inventors: **Gust H. Bardy**, Carnation, WA (US);  
**Jon Mikalson Bishey**, Seattle, WA (US);  
**Jason Felix**, Vashon Island, WA (US)

(73) Assignee: **Bardy Diagnostics, Inc.**, Vashon, WA (US)

(21) Appl. No.: **14/082,102**

(22) Filed: **Nov. 15, 2013**

**Related U.S. Application Data**

(63) Continuation-in-part of application No. 14/080,717, filed on Nov. 14, 2013, Continuation-in-part of application No. 14/080,725, filed on Nov. 14, 2013.

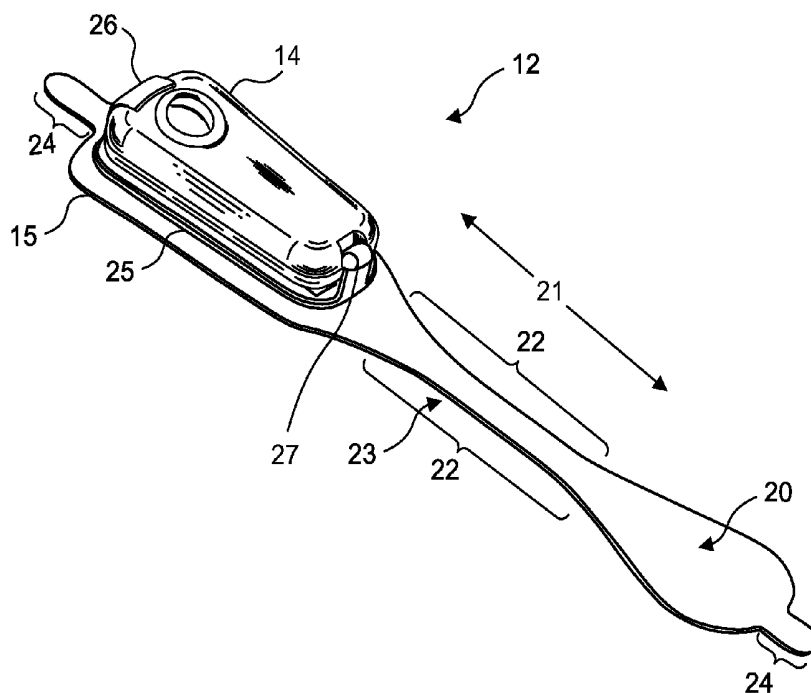
(60) Provisional application No. 61/882,403, filed on Sep. 25, 2013, provisional application No. 61/882,403, filed on Sep. 25, 2013.

**Publication Classification**

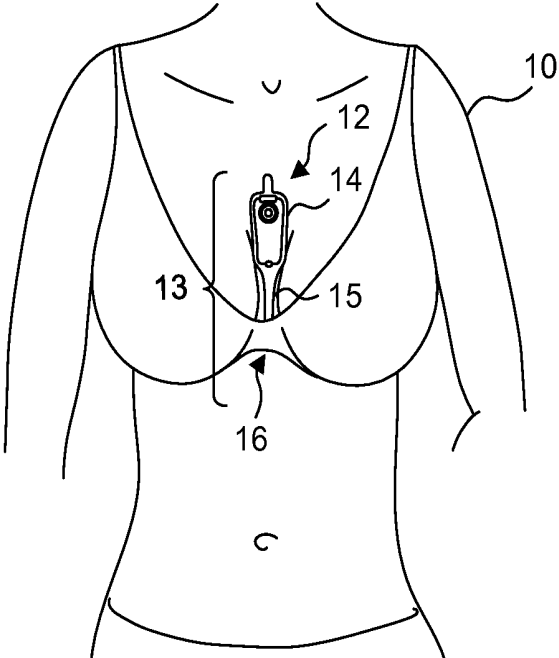
(51) **Int. Cl.**  
*A61B 5/0205* (2006.01)  
*A61B 5/0408* (2006.01)  
*A61B 5/0432* (2006.01)  
*A61B 5/03* (2006.01)  
*A61B 5/01* (2006.01)

(57) **ABSTRACT**

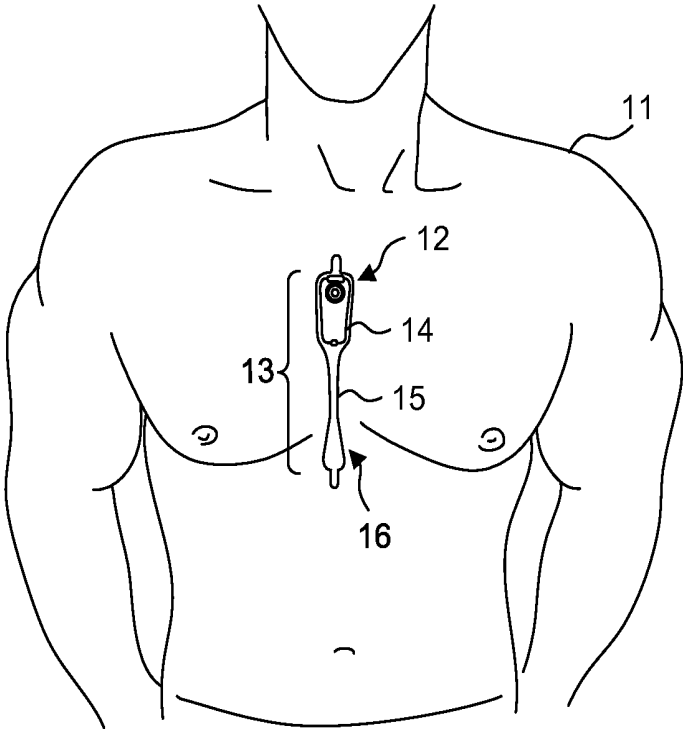
Physiological monitoring can be provided through a wearable monitor that includes two components, a flexible extended wear electrode patch and a removable reusable monitor recorder. The wearable monitor sits centrally (in the midline) on the patient's chest along the sternum oriented top-to-bottom. The placement of the wearable monitor in a location at the sternal midline (or immediately to either side of the sternum) benefits extended wear by removing the requirement that ECG electrodes be continually placed in the same spots on the skin throughout the monitoring period. Instead, the patient can place an electrode patch anywhere within the general region of the sternum. Power is provided through a battery provided on the electrode patch, which avoids having to open the monitor recorder's housing for battery replacement. The monitor further includes sensors for monitoring patient's air flow and respiratory measures contemporaneously with the ECG monitoring.



**Fig. 1.**



**Fig. 2.**



**Fig. 3.**

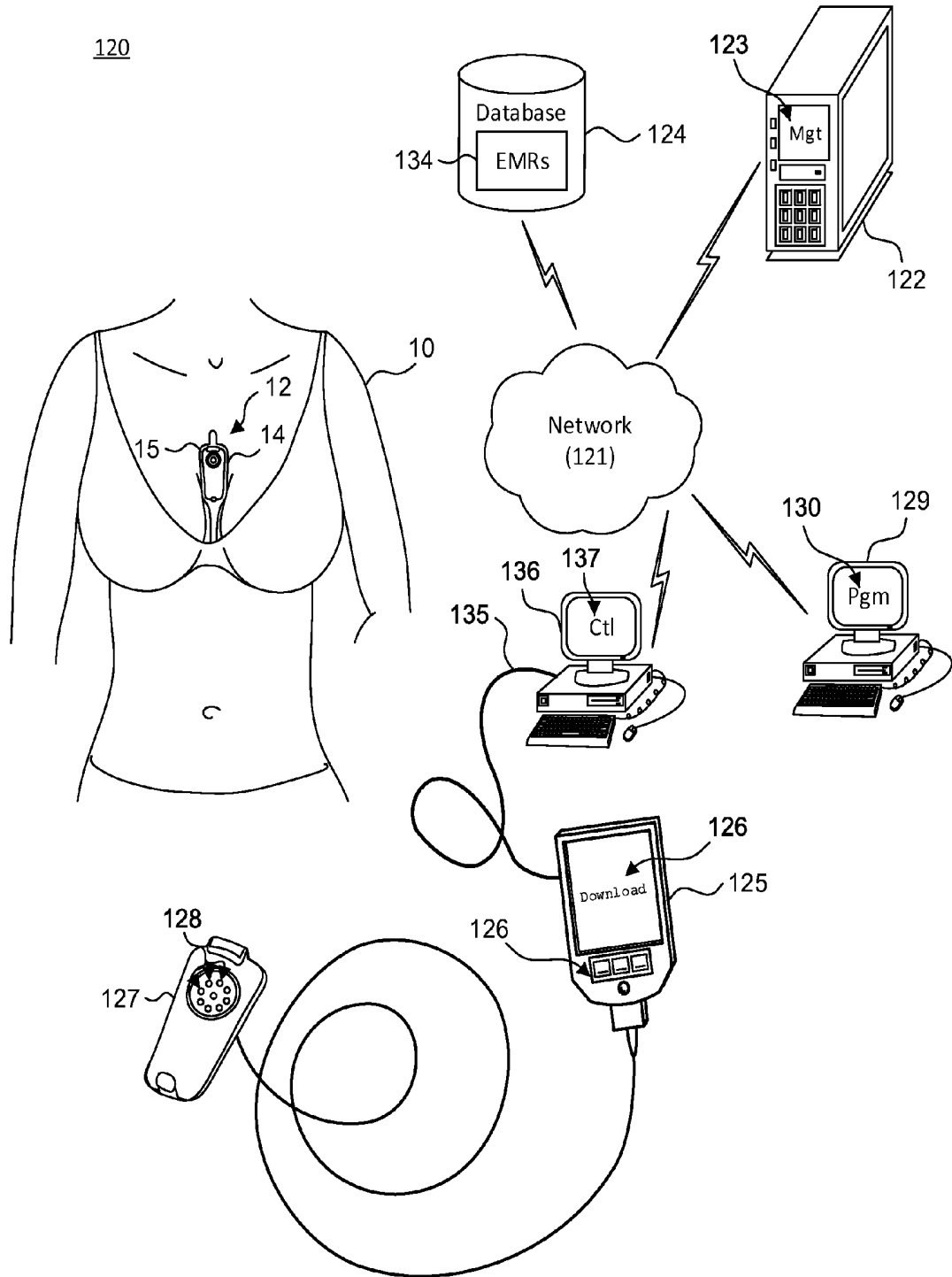


Fig. 4.

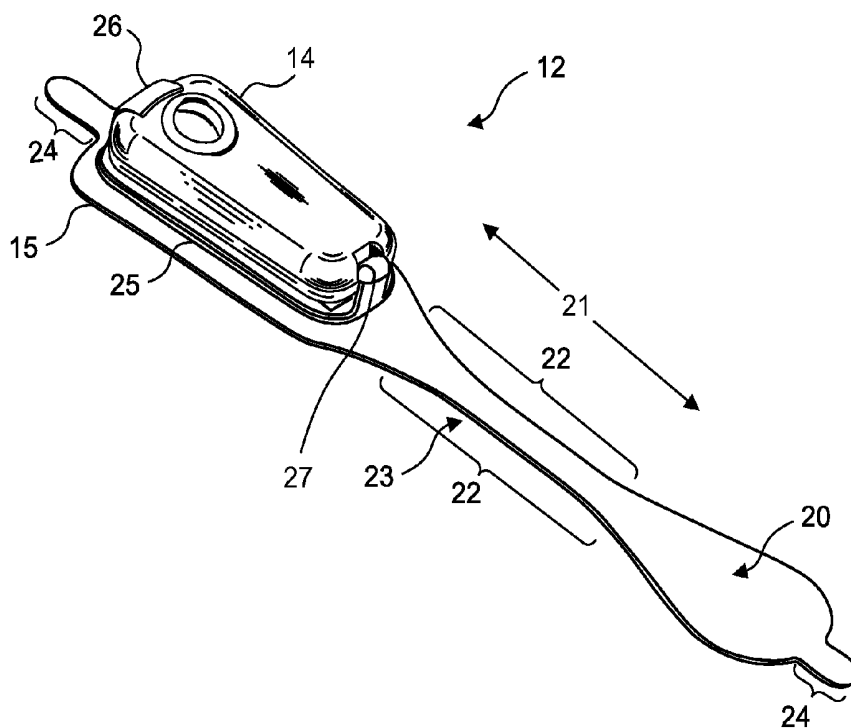
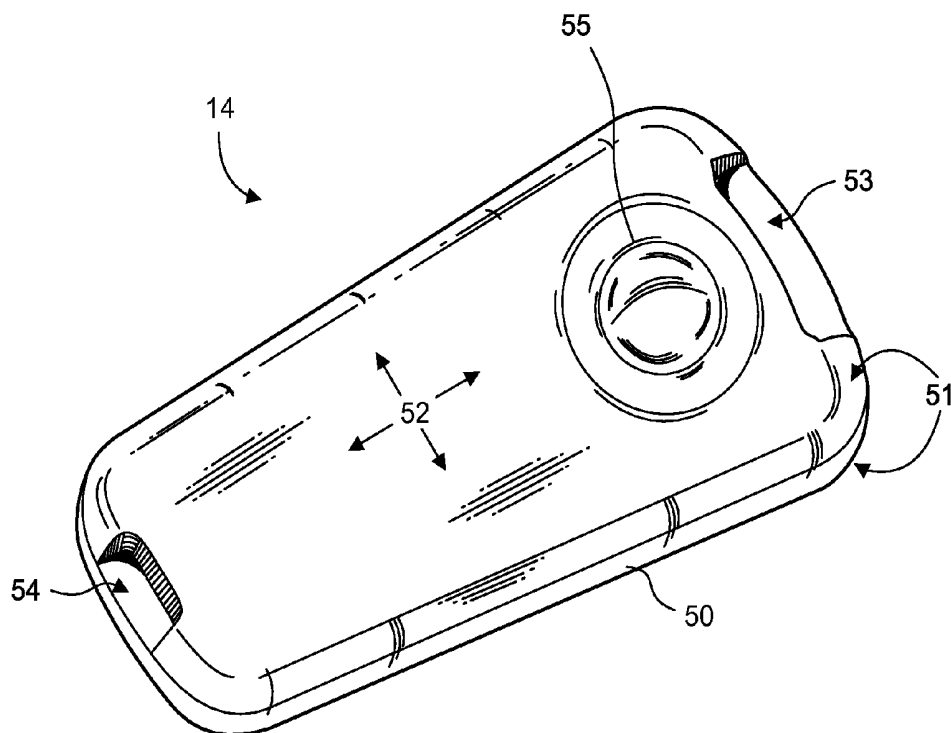
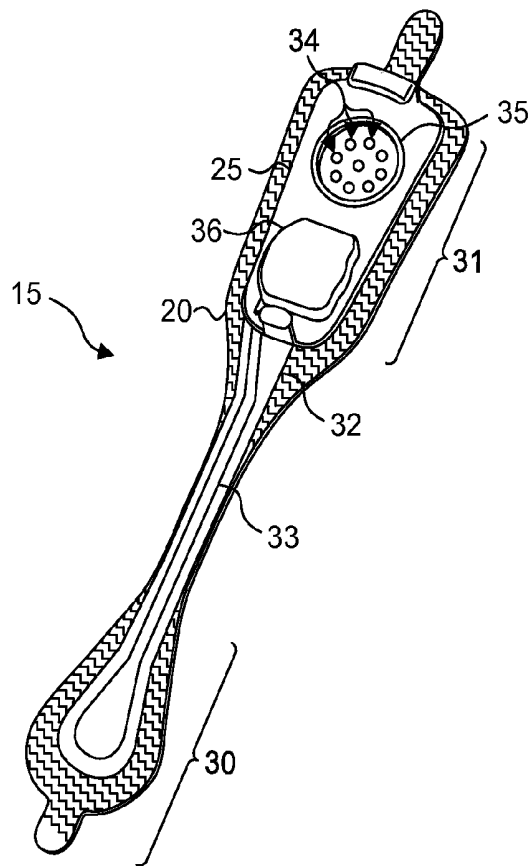


Fig. 5.



**Fig. 6.**



**Fig. 7.**

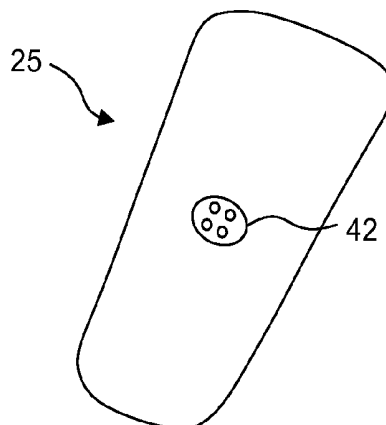


Fig. 8.

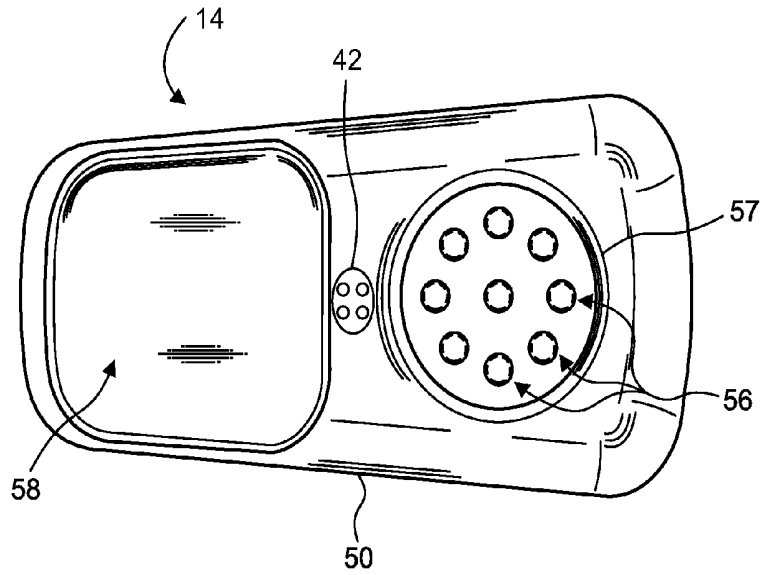


Fig. 9.

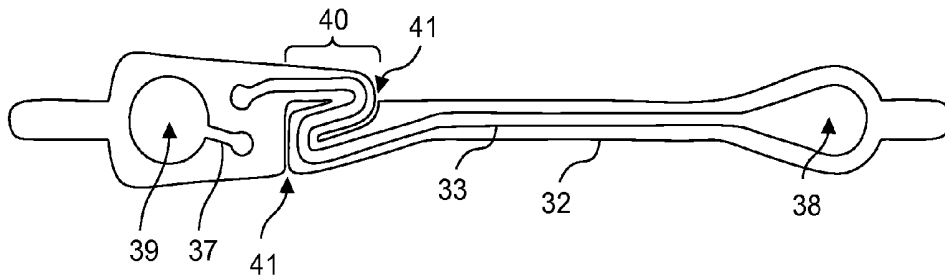


Fig. 10.

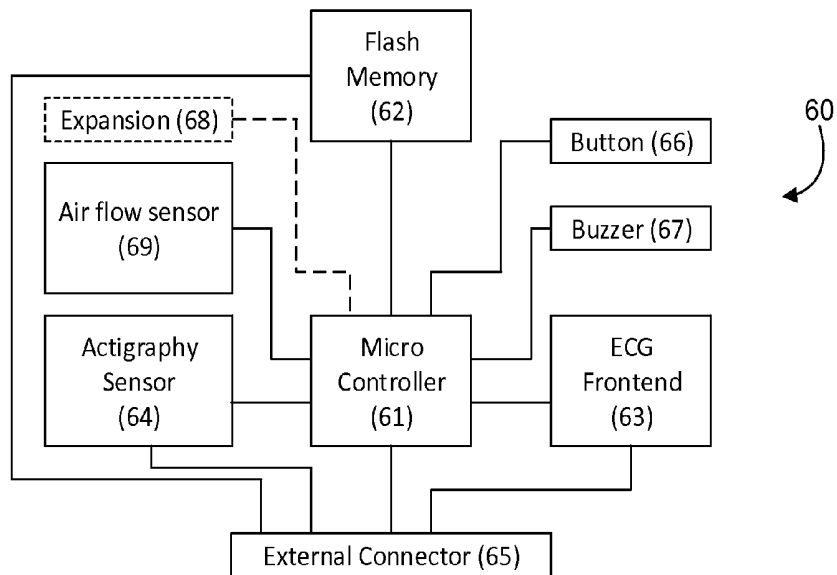
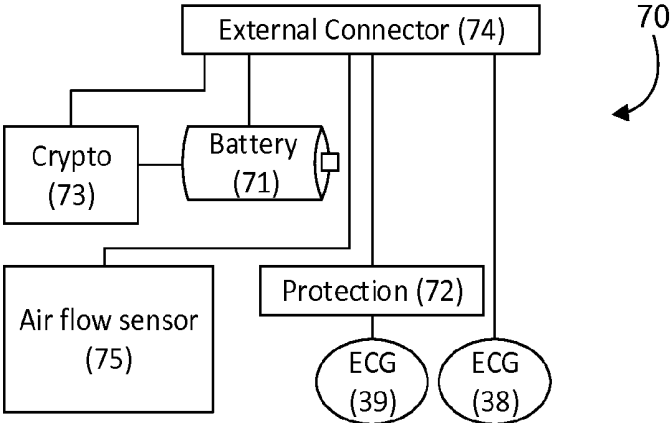
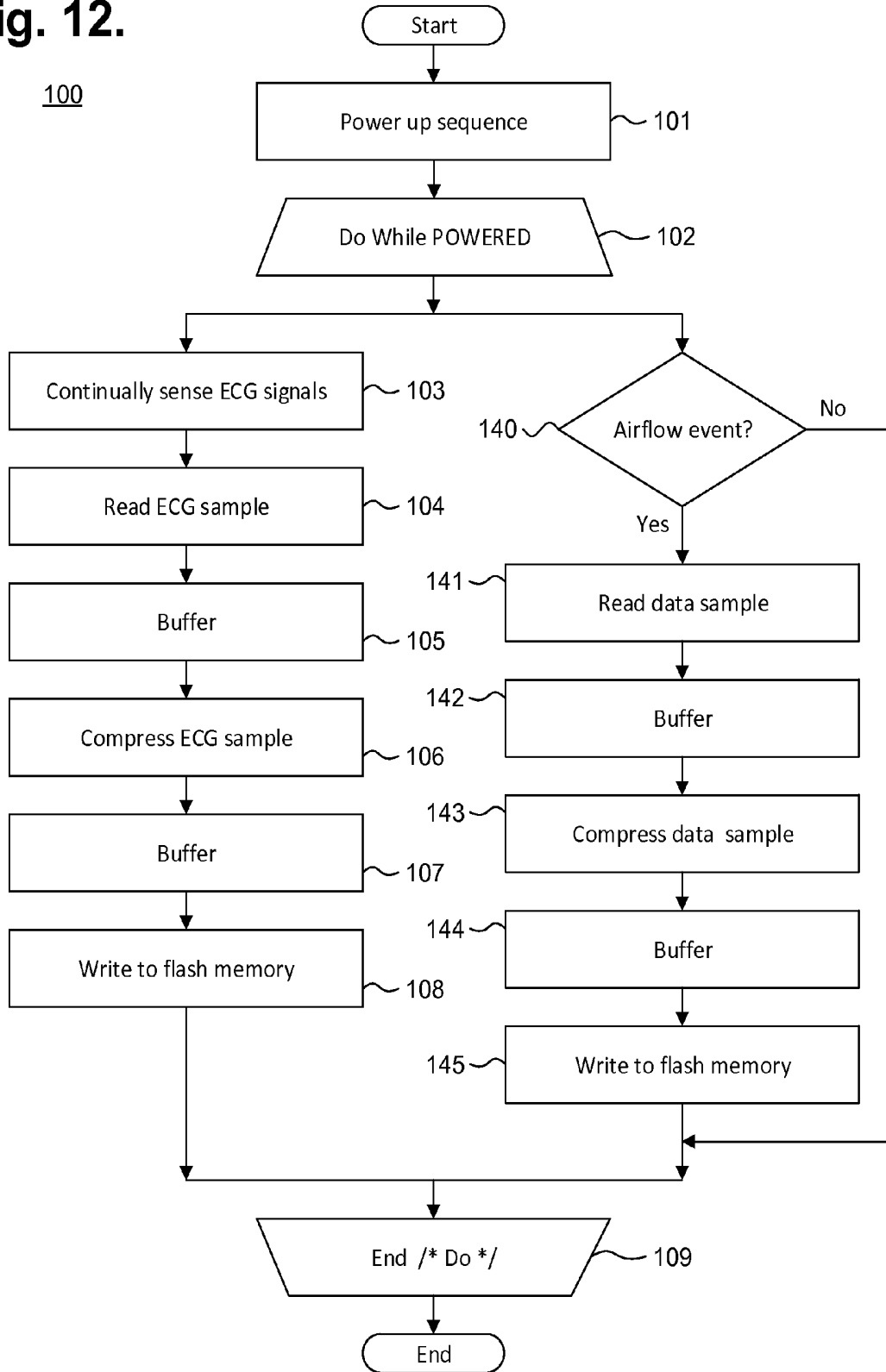


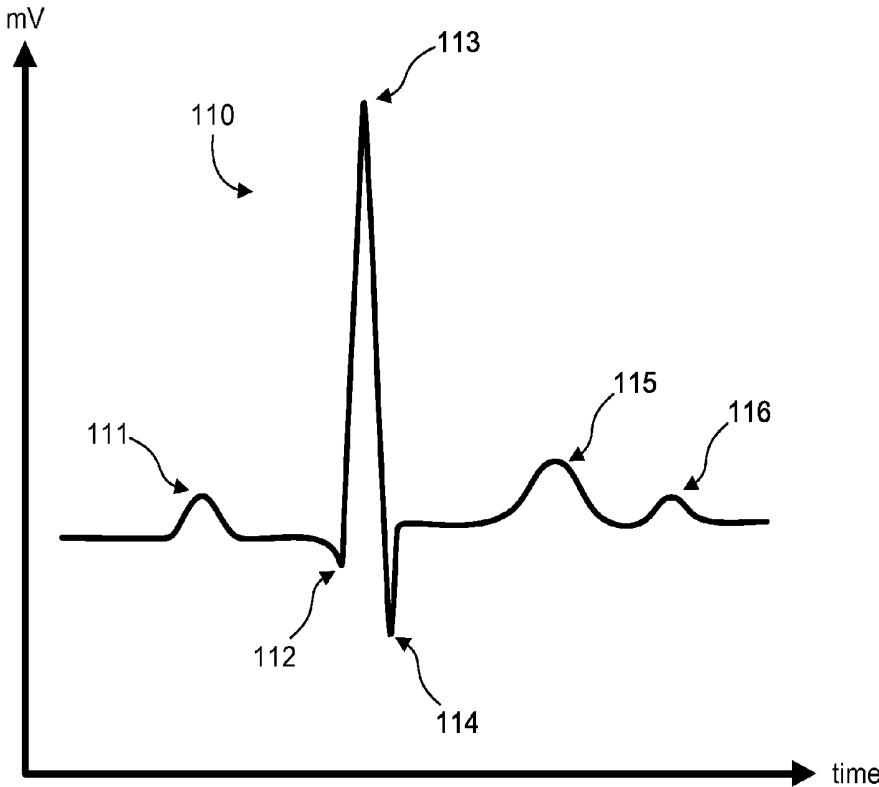
Fig. 11.



**Fig. 12.**

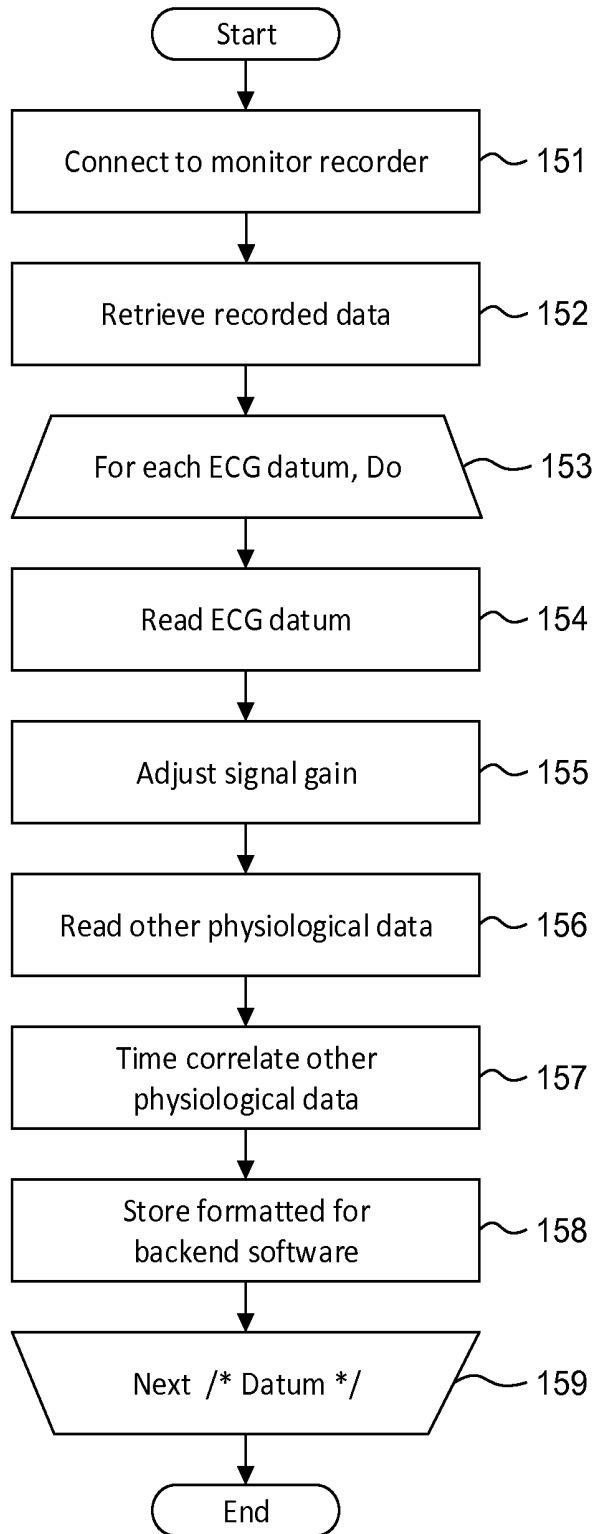


**Fig. 13.**



**Fig. 14.**

150



**Fig. 15.**

160

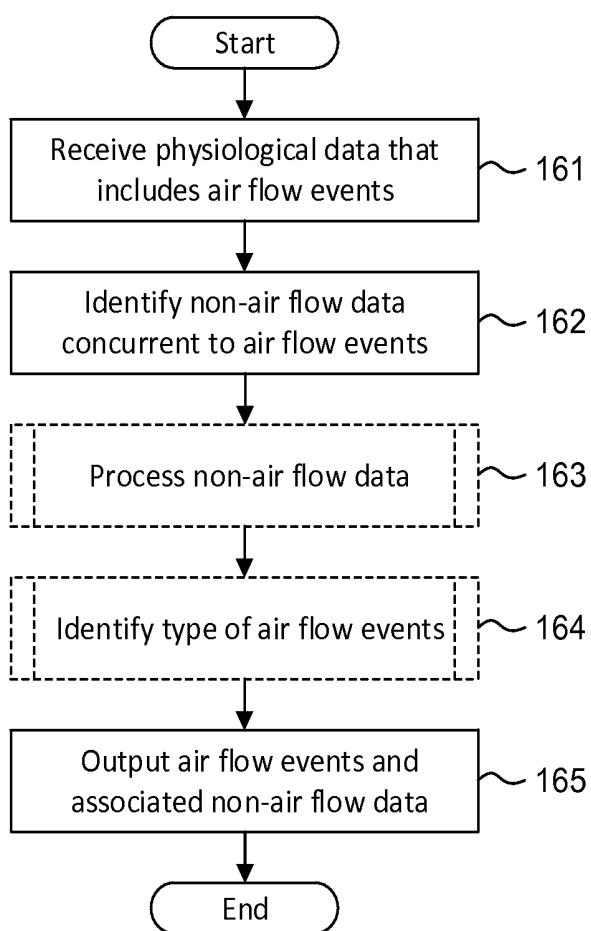
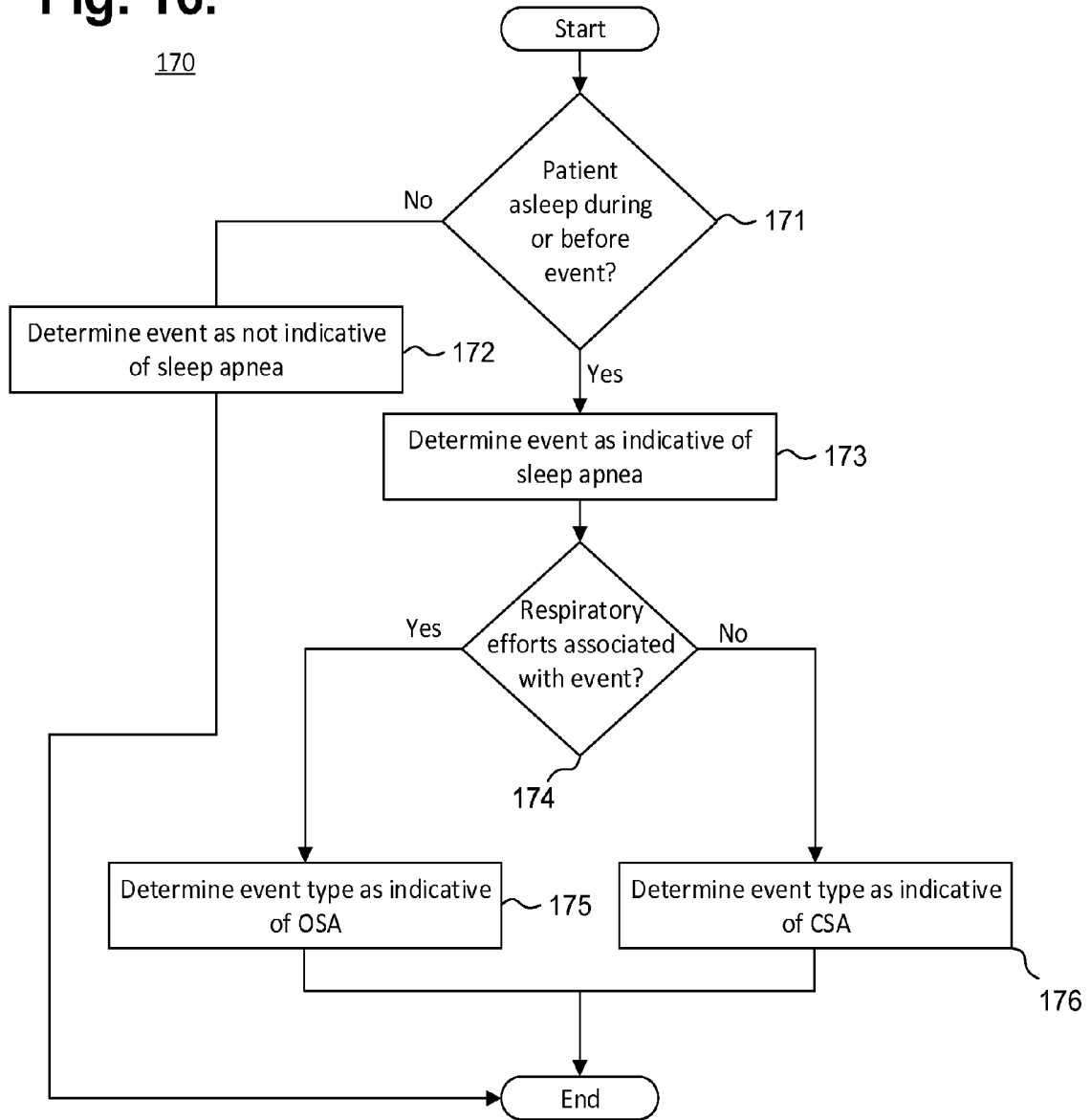
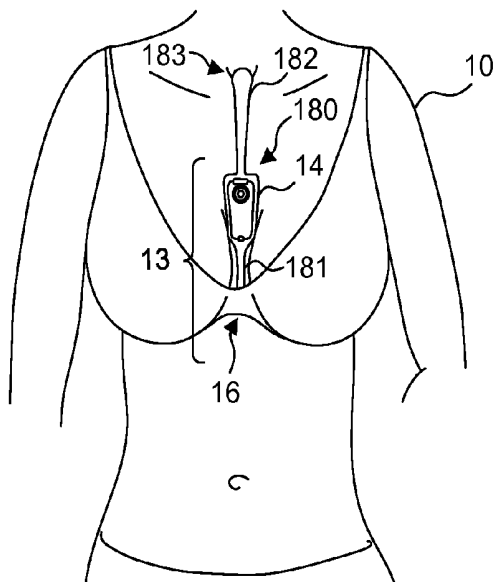


Fig. 16.



**Fig. 17.**



**Fig. 18.**

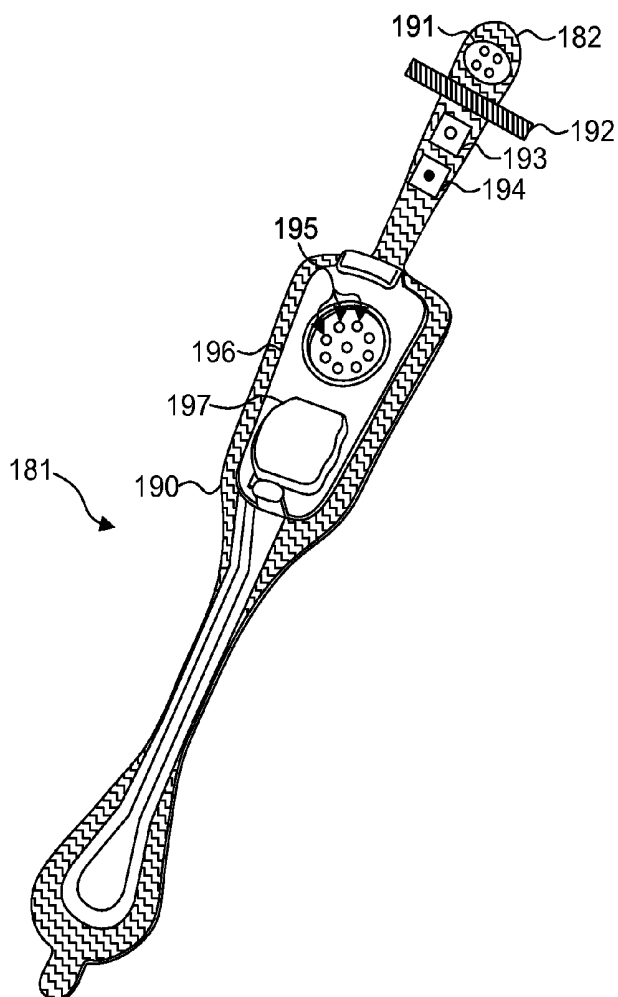
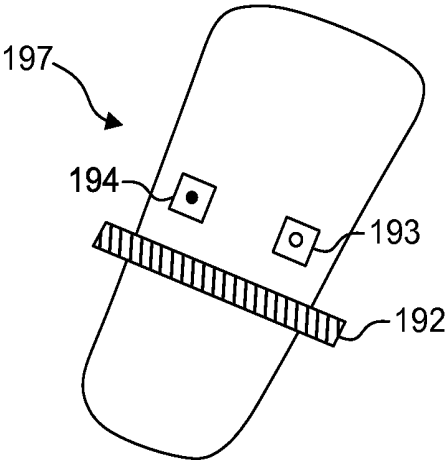


Fig. 19.



## SELF-CONTAINED PERSONAL AIR FLOW SENSING MONITOR

### CROSS-REFERENCE TO RELATED APPLICATION

**[0001]** This non-provisional patent application is a continuation-in-part of U.S. patent application Ser. No. 14/080,717, filed Nov. 14, 2013, pending, and a continuation-in-part of U.S. patent application Ser. No. 14/080,725, filed Nov. 14, 2013, pending, and further claims priority under 35 U.S.C. §119(e) to U.S. Provisional Patent application, Ser. No. 61/882,403, filed Sep. 25, 2013, the disclosures of which are incorporated by reference.

### FIELD

**[0002]** This application relates in general to electrocardiographic monitoring and, in particular, to a self-contained personal air flow sensing monitor.

### BACKGROUND

**[0003]** The heart emits electrical signals as a by-product of the propagation of the action potentials that trigger depolarization of heart fibers. An electrocardiogram (ECG) measures and records such electrical potentials to visually depict the electrical activity of the heart over time. Conventionally, a standardized set format 12-lead configuration is used by an ECG machine to record cardiac electrical signals from well-established traditional chest locations. Electrodes at the end of each lead are placed on the skin over the anterior thoracic region of the patient's body to the lower right and to the lower left of the sternum, on the left anterior chest, and on the limbs. Sensed cardiac electrical activity is represented by PQRSTU waveforms that can be interpreted post-ECG recordation to derive heart rate and physiology. The P-wave represents atrial electrical activity. The QRSTU components represent ventricular electrical activity.

**[0004]** An ECG is a tool used by physicians to diagnose heart problems and other potential health concerns. An ECG is a snapshot of heart function, typically recorded over 12 seconds, that can help diagnose rate and regularity of heartbeats, effect of drugs or cardiac devices, including pacemakers and implantable cardioverter-defibrillators (ICDs), and whether a patient has heart disease. ECGs are used in-clinic during appointments, and, as a result, are limited to recording only those heart-related aspects present at the time of recording. Sporadic conditions that may not show up during a spot ECG recording require other means to diagnose them. These disorders include fainting or syncope; rhythm disorders, such as tachyarrhythmias and bradyarrhythmias; apneic episodes; and other cardiac and related disorders. Thus, an ECG only provides a partial picture and can be insufficient for complete patient diagnosis of many cardiac disorders.

**[0005]** The inadequacy of conventional, short-term, ECG recordings is particularly apparent in the case of sleep apnea, a type of sleep disorder that affects a patient's breathing during sleep and may also impact the patient's cardiac activity. ECG monitoring alone may not be useful in diagnosing the condition due to a natural heart rate reduction during sleep. As a patient enters non-rapid eye movement (NREM) sleep, the patient experiences physiological changes due to a withdrawal of activity of the patient's sympathetic nervous system. As a result, even healthy people may experience sinus bradyarrhythmia during sleep, and ECG monitoring alone

may not always reveal whether the bradyarrhythmia is naturally-occurring or is caused by a pathological condition, such as an apneic episode. Furthermore, if the patient experiences other types of arrhythmias during sleep, without having a telemetry of the patient's air flow, the flow of air in and out of the patient's lungs during breathing, or another indicator of the patient's respiration, the physician may not be always be able to determine if an arrhythmia is a result of a sleep apnea episode or of some other morbidity. However, considering that cardiac manifestations of sleep apnea are most apparent at night, a short-term ECG monitoring done in a clinic during business hours may not reveal even the presence of the cardiac arrhythmia.

**[0006]** Diagnostic efficacy can be improved, when appropriate, through the use of long-term extended ECG monitoring coupled to pulmonary measures. Recording sufficient ECG and related physiology over an extended period is challenging, and often essential to enabling a physician to identify events of potential concern. A 30-day observation period is considered the "gold standard" of ECG monitoring, yet achieving a 30-day observation day period has proven unworkable because such ECG monitoring systems are arduous to employ, cumbersome to the patient, and excessively costly. Ambulatory monitoring in-clinic is implausible and impracticable. Nevertheless, if a patient's ECG and pulmonary measures could be recorded in an ambulatory setting, thereby allowing the patient to engage in activities of daily living, the chances of acquiring meaningful information and capturing an abnormal event while the patient is engaged in normal activities becomes more likely to be achieved.

**[0007]** For instance, the long-term wear of ECG electrodes is complicated by skin irritation and the inability ECG electrodes to maintain continual skin contact after a day or two. Moreover, time, dirt, moisture, and other environmental contaminants, as well as perspiration, skin oil, and dead skin cells from the patient's body, can get between an ECG electrode, the non-conductive adhesive used to adhere the ECG electrode, and the skin's surface. All of these factors adversely affect electrode adhesion and the quality of cardiac signal recordings. Furthermore, the physical movements of the patient and their clothing impart various compressional, tensile, and torsional forces on the contact point of an ECG electrode, especially over long recording times, and an inflexibly fastened ECG electrode will be prone to becoming dislodged. Notwithstanding the cause of electrode dislodgment, depending upon the type of ECG monitor employed, precise re-placement of a dislodged ECG electrode maybe essential to ensuring signal capture at the same fidelity. Moreover, dislodgment may occur unbeknownst to the patient, making the ECG recordings worthless. Further, some patients may have skin that is susceptible to itching or irritation, and the wearing of ECG electrodes can aggravate such skin conditions. Thus, a patient may want or need to periodically remove or replace ECG electrodes during a long-term ECG monitoring period, whether to replace a dislodged electrode, reestablish better adhesion, alleviate itching or irritation, allow for cleansing of the skin, allow for showering and exercise, or for other purpose. Such replacement or slight alteration in electrode location actually facilitates the goal of recording the ECG signal for long periods of time.

**[0008]** Conventionally, Holter monitors are widely used for long-term extended ECG monitoring. Typically, they are used for only 24-48 hours. A typical Holter monitor is a wearable and portable version of an ECG that include cables for each

electrode placed on the skin and a separate battery-powered ECG recorder. The cable and electrode combination (or leads) are placed in the anterior thoracic region in a manner similar to what is done with an in-clinic standard ECG machine. The duration of a Holter monitoring recording depends on the sensing and storage capabilities of the monitor, as well as battery life. A "looping" Holter monitor (or event) can operate for a longer period of time by overwriting older ECG tracings, thence "recycling" storage in favor of extended operation, yet at the risk of losing event data. Although capable of extended ECG monitoring, Holter monitors are cumbersome, expensive and typically only available by medical prescription, which limits their usability. Further, the skill required to properly place the electrodes on the patient's chest hinders or precludes a patient from replacing or removing the precordial leads and usually involves moving the patient from the physician office to a specialized center within the hospital or clinic. Also, Holter monitors do not provide information about the patient's air flow, further limiting their usefulness in diagnosing the patient.

**[0009]** The ZIO XT Patch and ZIO Event Card devices, manufactured by iRhythm Tech., Inc., San Francisco, Calif., are wearable stick-on monitoring devices that are typically worn on the upper left pectoral region to respectively provide continuous and looping ECG recording. The location is used to simulate surgically implanted monitors. Both of these devices are prescription-only and for single patient use. The ZIO XT Patch device is limited to a 14-day monitoring period, while the electrodes only of the ZIO Event Card device can be worn for up to 30 days. The ZIO XT Patch device combines both electronic recordation components, including battery, and physical electrodes into a unitary assembly that adheres to the patient's skin. The ZIO XT Patch device uses adhesive sufficiently strong to support the weight of both the monitor and the electrodes over an extended period of time and to resist disadherence from the patient's body, albeit at the cost of disallowing removal or relocation during the monitoring period. Moreover, throughout monitoring, the battery is continually depleted and battery capacity can potentially limit overall monitoring duration. The ZIO Event Card device is a form of downsized Holter monitor with a recorder component that must be removed temporarily during baths or other activities that could damage the non-waterproof electronics. Both devices represent compromises between length of wear and quality of ECG monitoring, especially with respect to ease of long term use, female-friendly fit, and quality of atrial (P-wave) signals. Furthermore, both devices do not monitor the patient's air flow, further limiting their usefulness in diagnosing the patient.

**[0010]** While portable devices that combine respiratory and cardiac monitoring exist, these devices are also generally inadequate for long-term monitoring due to their inconvenience and restraint that they place on the patient's movements. For example, SleepView monitor devices, manufactured by Cleveland Medical Devices Inc. of Cleveland, Ohio, require a patient to wear multiple sensors on the patient's body, including a belt on the patient's chest, a nasal cannula, and an oximetry sensor on the patient's finger, with these sensors being connected by tubing and wires to a recording device worn on the belt. Having to wear these sensors throughout the patient's body limits the patient's mobility and may be embarrassing to the patient if worn in public, deterring the patient from undergoing such a monitoring for an extended period of time.

**[0011]** Therefore, a need remains for a self-contained personal air flow monitor capable of recording both air flow data, other respiratory data such as respiratory rate and effort, and ECG data, practicably capable of being worn for a long period of time in both men and women, and capable of recording atrial signals reliably.

**[0012]** A further need remains for a device capable of recording signals ideal for arrhythmia discrimination, especially a device designed for atrial activity recording, as the arrhythmias are coupled to the associated pulmonary problems common to sleep apnea and other respiratory disorders.

#### SUMMARY

**[0013]** Physiological monitoring can be provided through a wearable monitor that includes two components, a flexible extended wear electrode patch and a removable reusable monitor recorder. The wearable monitor sits centrally (in the midline) on the patient's chest along the sternum oriented top-to-bottom. The placement of the wearable monitor in a location at the sternal midline (or immediately to either side of the sternum), with its unique narrow "hourglass"-like shape, benefits long-term extended wear by removing the requirement that ECG electrodes be continually placed in the same spots on the skin throughout the monitoring period. Instead, the patient is free to place an electrode patch anywhere within the general region of the sternum, the area most likely to record high quality atrial signals or P-waves. In addition, power is provided through a battery provided on the electrode patch, which avoids having to either periodically open the housing of the monitor recorder for the battery replacement, which also creates the potential for moisture intrusion and human error, or to recharge the battery, which can potentially take the monitor recorder off line for hours at a time. In addition, the electrode patch is intended to be disposable, while the monitor recorder is a reusable component. Thus, each time that the electrode patch is replaced, a fresh battery is provided for the use of the monitor recorder. The wearable monitor further includes an air flow sensor and air flow telemetry can be collected contemporaneously with ECG data either with sensors contained on the underlying dermal patch or with a hub-and-spoke configuration that allows for either a direct sensor contact with the monitor or a wirelessly relayed transfer of air flow and pulmonary data to the central monitor.

**[0014]** One embodiment provides a self-contained personal air flow sensing monitor recorder. A sealed housing is adapted to be removably secured into the non-conductive receptacle on a disposable extended wear electrode patch. Electronic circuitry is included within the sealed housing. An externally-powered micro-controller is operable to execute under micro programmable control and is electrically interfaced to one or more respiratory sensors comprising an air flow sensor and at least one of an SPO2 sensor, a PCO2 sensor, and a respiratory rate sensor, the one or more respiratory sensors comprised within at least one of the disposable extended wear electrode patch and the sealed housing. An electrocardiographic front end circuit is electrically interfaced to the micro-controller and is operable to sense electrocardiographic signals through electrocardiographic electrodes provided on the disposable extended wear electrode patch. Externally-powered flash memory is electrically interfaced with the micro-controller and is operable to store samples of the electrocardiographic signals and respiratory events including air flow events detected by the respiratory

sensors. In a further embodiment, one or more of the respiratory sensors can be included on an elongated tab that can extend over a patient's sternal notch, proximal to the patient's trachea.

**[0015]** A further embodiment provides a self-contained personal air flow sensing monitor. A disposable extended wear electrode patch includes a flexible backing formed of an elongated strip of stretchable material with a narrow longitudinal midsection and, on each end, a contact surface is at least partially coated with an adhesive dressing provided as a crimp relief. A pair of electrocardiographic electrodes is conductively exposed on the contact surface of each end of the elongated strip. A non-conductive receptacle is adhered to an outward-facing end of the elongated strip and includes a plurality of electrical pads. A flexible circuit is affixed on each end of the elongated strip as a strain relief and includes a pair of circuit traces electrically coupled to the pair of electrocardiographic electrodes and a pair of the electrical pads. A reusable electrocardiography monitor has a sealed housing adapted to be removably secured into the non-conductive receptacle. A micro-controller is operable to execute under micro programmable control and is electrically interfaced to an electrocardiographic front end circuit that is operable to sense electrocardiographic signals through the electrocardiographic electrodes via the pair of electrical pads. An air flow sensor is operable to sense air flow events, the air flow sensor electrically interfaced with the micro-controller over an expansion bus operatively interconnected to the micro-controller. A flash memory is electrically interfaced with the micro-controller and is operable to store samples of the electrocardiographic signals and the air flow events.

**[0016]** An even further embodiment provides a self-contained personal monitor with a disposable air flow sensing component. A disposable extended wear electrode patch includes a flexible backing formed of an elongated strip of stretchable material with a narrow longitudinal midsection and, on each end, a contact surface is at least partially coated with an adhesive dressing provided as a crimp relief. A pair of electrocardiographic electrodes is conductively exposed on the contact surface of each end of the elongated strip. A non-conductive receptacle is adhered to an outward-facing end of the elongated strip and includes a plurality of electrical pads. A flexible circuit is affixed on each end of the elongated strip as a strain relief and includes a pair of circuit traces electrically coupled to the pair of electrocardiographic electrodes and a pair of the electrical pads. Respiratory event sensors that include an air flow sensor and a respiratory rate sensor are electrically coupled to at least one of the electrical pads and operable to sense air flow events. A reusable electrocardiography monitor has a sealed housing adapted to be removably secured into the non-conductive receptacle. A micro-controller is operable to execute under micro programmable control and is electrically interfaced to an electrocardiographic front end circuit that is operable to sense electrocardiographic signals through the electrocardiographic electrodes via the pair of electrical pads, the micro-controller further being electrically interfaced to the air flow sensor over an expansion bus electrically coupled to the at least one electrical pad. A flash memory is electrically interfaced with the micro-controller and is operable to store samples of the electrocardiographic signals and respiratory events comprising air flow events and respiratory rate events.

**[0017]** The monitoring patch is especially suited to the female anatomy. The narrow longitudinal midsection can fit

nicely within the intermammary cleft of the breasts without inducing discomfort, whereas conventional patch electrodes are wide and, if adhered between the breasts, would cause chafing, irritation, frustration, and annoyance, leading to low patient compliance.

**[0018]** The foregoing aspects enhance ECG monitoring performance and quality facilitating long-term ECG recording, critical to accurate arrhythmia diagnosis.

**[0019]** In addition, the foregoing aspects enhance comfort in women (and certain men), but not irritation of the breasts, by placing the monitoring patch in the best location possible for optimizing the recording of cardiac signals from the atrium, another feature critical to proper arrhythmia diagnosis. And, such ECG recording systems can easily be interfaced with air flow and respiratory recording systems that can extend cephalad to the sternum for recording tracheal airflow and for monitoring respiratory rate and underlying dermal SpO<sub>2</sub> and pCO<sub>2</sub> measures, all features of pulmonary disorders.

**[0020]** Finally, the foregoing aspects as relevant to monitoring are equally applicable to recording other physiological measures, such as temperature, respiratory rate, blood sugar, oxygen saturation, and blood pressure, as well as other measures of body chemistry and physiology. Still other embodiments will become readily apparent to those skilled in the art from the following detailed description, wherein are described embodiments by way of illustrating the best mode contemplated. As will be realized, other and different embodiments are possible and the embodiments' several details are capable of modifications in various obvious respects, all without departing from their spirit and the scope. Accordingly, the drawings and detailed description are to be regarded as illustrative in nature and not as restrictive.

#### BRIEF DESCRIPTION OF THE DRAWINGS

**[0021]** FIGS. 1 and 2 are diagrams showing, by way of examples, a self-contained personal air flow sensing monitor, including a monitor recorder in accordance with one embodiment, respectively fitted to the sternal region of a female patient and a male patient.

**[0022]** FIG. 3 is a perspective view showing a system for remote interfacing of a self-contained personal air flow sensing monitor in accordance with one embodiment inserted.

**[0023]** FIG. 4 is a perspective view showing an extended wear electrode patch with the monitor recorder in accordance with one embodiment.

**[0024]** FIG. 5 is a perspective view showing the monitor recorder of FIG. 4.

**[0025]** FIG. 6 is a perspective view showing the extended wear electrode patch of FIG. 4 without a monitor recorder inserted.

**[0026]** FIG. 7 is an alternative view of the non-conductive receptacle 25 of FIG. 6.

**[0027]** FIG. 8 is a bottom plan view of the monitor recorder of FIG. 4.

**[0028]** FIG. 9 is a top view showing the flexible circuit of the extended wear electrode patch of FIG. 4 when mounted above the flexible backing.

**[0029]** FIG. 10 is a functional block diagram showing the component architecture of the circuitry of the monitor recorder of FIG. 4.

**[0030]** FIG. 11 is a functional block diagram showing the circuitry of the extended wear electrode patch of FIG. 4.

[0031] FIG. 12 is a flow diagram showing a monitor recorder-implemented method for monitoring ECG and air flow data for use in the monitor recorder of FIG. 4.

[0032] FIG. 13 is a graph showing, by way of example, a typical ECG waveform.

[0033] FIG. 14 is a flow diagram showing a method for offloading and converting ECG and other physiological data from a self-contained air flow sensing monitor in accordance with one embodiment.

[0034] FIG. 15 is a flow diagram showing method for processing data collected by the self-contained personal air flow sensing monitor in accordance with one embodiment.

[0035] FIG. 16 is a flow diagram showing a routine for identifying a type of an air flow event for use in the method of FIG. 15 in accordance with one embodiment.

[0036] FIG. 17 is a diagram showing, by way of example, a self-contained personal air flow sensing monitor fitted to the sternal region of a female patient 10 in accordance with a further embodiment.

[0037] FIG. 18 is a perspective view showing the extended wear electrode patch with an elongated tab in accordance with one embodiment without the monitor 14 inserted in accordance with one embodiment.

[0038] FIG. 19 shows an alternative perspective view of the non-conductive receptacle 196 of FIG. 18 in accordance with one embodiment

#### DETAILED DESCRIPTION

[0039] Long-term collection of air flow telemetry contemporaneous with collection of ECG data allows a physician interpreting physiological monitoring results to correlate abnormal respiratory and cardiac events, helping the physician in diagnosing the patient. Results of such a monitoring can be particularly useful for diagnosing sleep apnea conditions, which have both respiratory and cardiac components. For example, obstructive sleep apnea (OSA) is a disorder characterized by physical occlusion of upper airways during a patient's sleep, which causes either an apnea, a complete cessation of air flow, or a hypopnea, a partial cessation of air flow. An OSA episode causes the patient to transiently awaken to a lighter stage of sleep, the awakening followed by a restoration of the air flow. The occlusion causes a hypoxemia, an abnormal decrease in blood oxygen level, and is accompanied by strenuous respiratory efforts, such as thoracoabdominal movements, of the patient. OSA episodes may further be accompanied by cardiac arrhythmias. The hypoxemia is accompanied by a rise in peripheral sympathetic activity, which in turn may trigger a tachyarrhythmia once the patient's respiration resumes. The sympathetic activity may remain at a heightened level even during the patient's wakefulness, triggering further tachyarrhythmias. Furthermore, in some patients, the hypoxemia can be accompanied by cardiac parasympathetic activity, which can cause a profound nocturnal bradycardia.

[0040] Central sleep apnea (CSA), which can be a form of Cheyne-Stokes breathing, is similarly associated with cardiac abnormalities and has been estimated to occur in 30-40% of patients with heart failure. CSA is caused by a defect in central ventilatory control by the brain of the patient; due to the defect, the brain fails to send respiratory commands to the appropriate muscles, and the patient stops breathing. In contrast to OSA, the lack of respiratory commands results in respiratory efforts being absent during the OSA episode. As the patient stops breathing during a CSA episode, the patient

develops hypoxemia and hypercapnia, an abnormal increase in blood carbon dioxide levels; due to the rising hypoxemia and hypercapnia, the brain reinitiates breathing, with the breathing rate gradually rising until reaching the level of hyperpnea, abnormally deep breathing, which gradually ceases as the levels of blood oxygen and carbon dioxide are restored to normal. The patient's heart rate rises gradually with the rise of the respiration rate, and thus, the hyperpnea may trigger a tachyarrhythmia. Monitoring both air flow and cardiac activity of the patient allows to correlate the cardiac and respiratory abnormalities that OSA and CSA cause, and aid in diagnosing these conditions.

[0041] Physiological monitoring can be provided through a wearable monitor that includes two components, a flexible extended wear electrode patch and a removable reusable monitor recorder. FIGS. 1 and 2 are diagrams showing, by way of examples, a self-contained personal air flow sensing monitor 12, including a monitor recorder 14 in accordance with one embodiment, respectively fitted to the sternal region of a female patient 10 and a male patient 11. The wearable monitor 12 sits centrally (in the midline) on the patient's chest along the sternum 13 oriented top-to-bottom with the monitor recorder 14 preferably situated towards the patient's head. In a further embodiment, the orientation of the wearable monitor 12 can be corrected post-monitoring, as further described infra. The electrode patch 15 is shaped to fit comfortably and conformal to the contours of the patient's chest approximately centered on the sternal midline 16 (or immediately to either side of the sternum 13). The distal end of the electrode patch 15 extends towards the Xiphoid process and, depending upon the patient's build, may straddle the region over the Xiphoid process. The proximal end of the electrode patch 15, located under the monitor recorder 14, is below the manubrium and, depending upon patient's build, may straddle the region over the manubrium.

[0042] The placement of the wearable monitor 12 in a location at the sternal midline 16 (or immediately to either side of the sternum 13) significantly improves the ability of the wearable monitor 12 to cutaneously sense cardiac electric signals, particularly the P-wave (or atrial activity) and, to a lesser extent, the QRS interval signals in the ECG waveforms that indicate ventricular activity while simultaneously facilitating comfortable long-term wear for many weeks. The sternum 13 overlies the right atrium of the heart and the placement of the wearable monitor 12 in the region of the sternal midline 13 puts the ECG electrodes of the electrode patch 15 in a location better adapted to sensing and recording P-wave signals than other placement locations, say, the upper left pectoral region or lateral thoracic region or the limb leads. In addition, placing the lower or inferior pole (ECG electrode) of the electrode patch 15 over (or near) the Xiphoid process facilitates sensing of ventricular activity and provides superior recordation of the QRS interval.

[0043] The monitor recorder 14 of the wearable air flow sensing monitor 12 senses and records the patient's air flow and ECG data into an onboard memory. In addition, the wearable monitor 12 can interoperate with other devices. FIG. 3 is a functional block diagram showing a system 120 for remote interfacing of a self-contained personal air flow sensing monitor 12 in accordance with one embodiment. The monitor recorder 14 is a reusable component that can be fitted during patient monitoring into a non-conductive receptacle provided on the electrode patch 15, as further described infra with reference to FIG. 4, and later removed for offloading of

stored ECG data or to receive revised programming. Following completion of ECG and air flow monitoring, the monitor recorder **14** can then be connected to a download station **125**, which could be a programmer or other device that permits the retrieval of stored ECG monitoring data, execution of diagnostics on or programming of the monitor recorder **14**, or performance of other functions. The monitor recorder **14** has a set of electrical contacts (not shown) that enable the monitor recorder **14** to physically interface to a set of terminals **128** on a paired receptacle **127** of the download station **125**. In turn, the download station **125** executes a communications or offload program **126** (“Off-load”) or similar program that interacts with the monitor recorder **14** via the physical interface to retrieve the stored ECG monitoring data. The download station **125** could be a server, personal computer, tablet or handheld computer, smart mobile device, or purpose-built programmer designed specific to the task of interfacing with a monitor recorder **14**. Still other forms of download station **125** are possible.

**[0044]** Upon retrieving stored ECG monitoring data from a monitor recorder **14**, middleware first operates on the retrieved data to adjust the ECG waveform, as necessary, and to convert the retrieved data into a format suitable for use by third party post-monitoring analysis software, as further described infra with reference to FIG. **14**. The formatted data can then be retrieved from the download station **125** over a hard link **135** using a control program **137** (“Ctl”) or analogous application executing on a personal computer **136** or other connectable computing device, via a communications link (not shown), whether wired or wireless, or by physical transfer of storage media (not shown). The personal computer **136** or other connectable device may also execute middleware that converts ECG data and other information into a format suitable for use by a third-party post-monitoring analysis program, as further described infra with reference to FIG. **13**. Note that formatted data stored on the personal computer **136** would have to be maintained and safeguarded in the same manner as electronic medical records (EMRs) **134** in the secure database **124**, as further discussed infra. In a further embodiment, the download station **125** is able to directly interface with other devices over a computer communications network **121**, which could be some combination of a local area network and a wide area network, including the Internet, over a wired or wireless connection.

**[0045]** A client-server model could be used to employ a server **122** to remotely interface with the download station **125** over the network **121** and retrieve the formatted data or other information. The server **122** executes a patient management program **123** (“Mgt”) or similar application that stores the retrieved formatted data and other information in a secure database **124** cataloged in that patient’s EMRs **134**. In addition, the patient management program **123** could manage a subscription service that authorizes a monitor recorder **14** to operate for a set period of time or under pre-defined operational parameters, such as described in commonly-assigned U.S. patent application, entitled “Self-Authenticating Electrocardiography Monitoring Circuit,” Ser. No. \_\_\_\_\_, filed \_\_\_\_\_, pending, the disclosure of which is incorporated by reference.

**[0046]** The patient management program **123**, or other trusted application, also maintains and safeguards the secure database **124** to limit access to patient EMRs **134** to only authorized parties for appropriate medical or other uses, such as mandated by state or federal law, such as under the Health

Insurance Portability and Accountability Act (HIPAA) or per the European Union’s Data Protection Directive. For example, a physician may seek to review and evaluate his patient’s ECG monitoring data, as securely stored in the secure database **124**. The physician would execute an application program **130** (“Pgm”), such as a post-monitoring ECG analysis program, on a personal computer **129** or other connectable computing device, and, through the application **130**, coordinate access to his patient’s EMRs **134** with the patient management program **123**. Other schemes and safeguards to protect and maintain the integrity of patient EMRs **134** are possible.

**[0047]** During use, the electrode patch **15** is first adhered to the skin along the sternal midline **16** (or immediately to either side of the sternum **13**). A monitor recorder **14** is then snapped into place on the electrode patch **15** to initiate ECG monitoring. FIG. **4** is a perspective view showing an extended wear electrode patch **15** with a monitor recorder **14** inserted in accordance with one embodiment. The body of the electrode patch **15** is preferably constructed using a flexible backing **20** formed as an elongated strip **21** of wrap knit or similar stretchable material with a narrow longitudinal mid-section **23** evenly tapering inward from both sides. A pair of cut-outs **22** between the distal and proximal ends of the electrode patch **15** create a narrow longitudinal midsection **23** or “isthmus” and defines an elongated “hourglass”-like shape, when viewed from above. The electrode patch **15** incorporates features that significantly improve wearability, performance, and patient comfort throughout an extended monitoring period. During wear, the electrode patch **15** is susceptible to pushing, pulling, and torquing movements, including compressional and torsional forces when the patient bends forward, and tensile and torsional forces when the patient leans backwards. To counter these stress forces, the electrode patch **15** incorporates strain and crimp reliefs, such as described in commonly-assigned U.S. patent application, entitled “Extended Wear Electrocardiography Patch,” Ser. No. 14/080,717, filed Nov. 14, 2013, pending, the disclosure of which is incorporated by reference. In addition, the cut-outs **22** and longitudinal midsection **23** help minimize interference with and discomfort to breast tissue, particularly in women (and gynecomastic men). The cut-outs **22** and longitudinal midsection **23** further allow better conformity of the electrode patch **15** to sternal bowing and to the narrow isthmus of flat skin that can occur along the bottom of the intermammary cleft between the breasts, especially in buxom women. The cut-outs **22** and longitudinal midsection **23** help the electrode patch **15** fit nicely between a pair of female breasts in the intermammary cleft. Still other shapes, cut-outs and conformities to the electrode patch **15** are possible. For example, an elongated tab may extend from the flexible backing, as further described infra with reference to FIGS. **17-19**.

**[0048]** The monitor recorder **14** removably and reusably snaps into an electrically non-conductive receptacle **25** during use. The monitor recorder **14** contains electronic circuitry for recording and storing the patient’s electrocardiography as sensed via a pair of ECG electrodes provided on the electrode patch **15**, such as described in commonly-assigned U.S. patent application, entitled “Extended Wear Ambulatory Electrocardiography and Physiological Sensor Monitor,” Ser. No. 14/080,725, filed Nov. 14, 2013, pending, the disclosure of which is incorporated by reference. The non-conductive receptacle **25** is provided on the top surface of the flexible backing **20** with a retention catch **26** and tension clip **27**

molded into the non-conductive receptacle **25** to conformably receive and securely hold the monitor recorder **14** in place.

**[0049]** The monitor recorder **14** includes a sealed housing that snaps into place in the non-conductive receptacle **25**. FIG. **5** is a perspective view showing the monitor recorder **14** of FIG. **4**. The sealed housing **50** of the monitor recorder **14** intentionally has a rounded isosceles trapezoidal-like shape **52**, when viewed from above, such as described in commonly-assigned U.S. Design patent application, entitled "Electrocardiography Monitor," Serial No. 29/472,046, filed Nov. 7, 2013, pending, the disclosure of which is incorporated by reference. The edges **51** along the top and bottom surfaces are rounded for patient comfort. The sealed housing **50** is approximately 47 mm long, 23 mm wide at the widest point, and 7 mm high, excluding a patient-operable tactile-feedback button **55**. The sealed housing **50** can be molded out of polycarbonate, ABS, or an alloy of those two materials. The button **55** is waterproof and the button's top outer surface is molded silicon rubber or similar soft pliable material. A retention detent **53** and tension detent **54** are molded along the edges of the top surface of the housing **50** to respectively engage the retention catch **26** and the tension clip **27** molded into non-conductive receptacle **25**. Other shapes, features, and conformities of the sealed housing **50** are possible.

**[0050]** The electrode patch **15** is intended to be disposable. The monitor recorder **14**, however, is reusable and can be transferred to successive electrode patches **15** to ensure continuity of monitoring. The placement of the wearable monitor **12** in a location at the sternal midline **16** (or immediately to either side of the sternum **13**) benefits long-term extended wear by removing the requirement that ECG electrodes be continually placed in the same spots on the skin throughout the monitoring period. Instead, the patient is free to place an electrode patch **15** anywhere within the general region of the sternum **13**.

**[0051]** As a result, at any point during ECG monitoring, the patient's skin is able to recover from the wearing of an electrode patch **15**, which increases patient comfort and satisfaction, while the monitor recorder **14** ensures ECG monitoring continuity with minimal effort. A monitor recorder **14** is merely unsnapped from a worn out electrode patch **15**, the worn out electrode patch **15** is removed from the skin, a new electrode patch **15** is adhered to the skin, possibly in a new spot immediately adjacent to the earlier location, and the same monitor recorder **14** is snapped into the new electrode patch **15** to reinitiate and continue the ECG monitoring.

**[0052]** During use, the electrode patch **15** is first adhered to the skin in the sternal region. FIG. **6** is a perspective view showing the extended wear electrode patch **15** of FIG. **4** without a monitor recorder **14** inserted. A flexible circuit **32** is adhered to each end of the flexible backing **20**. A distal circuit trace **33** and a proximal circuit trace (not shown) electrically couple ECG electrodes (not shown) to a pair of electrical pads **34**. The electrical pads **34** are provided within a moisture-resistant seal **35** formed on the bottom surface of the non-conductive receptacle **25**. When the monitor recorder **14** is securely received into the non-conductive receptacle **25**, that is, snapped into place, the electrical pads **34** interface to electrical contacts (not shown) protruding from the bottom surface of the monitor recorder **14**, and the moisture-resistant seal **35** enables the monitor recorder **14** to be worn at all times, even during bathing or other activities that could expose the monitor recorder **14** to moisture.

**[0053]** In addition, a battery compartment **36** is formed on the bottom surface of the non-conductive receptacle **25**, and a pair of battery leads (not shown) electrically interface the battery to another pair of the electrical pads **34**. The battery contained within the battery compartment **35** can be replaceable, rechargeable or disposable.

**[0054]** The air flow monitor **12** can monitor a patient's physiology, including both the patient's air flow and ECG. FIG. **7** is an alternative perspective view of the non-conductive receptacle **25** in accordance with one embodiment, showing an air flow sensor **42** included on the surface of non-conductive receptacle **25** that faces the flexible backing **20**. The air flow sensor **42** includes a microphone that is positioned to detect sounds of breathing of the patient through the patient's sternum **13**. The microphone may also be able to record sounds associated with the breathing, such as snoring. The microphone can be a MicroElectrical-Mechanical System (MEMS) microphone, though other types of microphones can be used in a further embodiment. In a further embodiment, the air flow sensor can be located in a different part of the electrode patch **15**. In a still further embodiment, the air flow sensor **42** can be located on the monitor recorder **14**. While the air flow sensor is shown to be the only component present on the surface of the non-conductive receptacle, other components may also be present on the surface. For example, an SPO<sub>2</sub> sensor to measure blood oxygen level (not shown) can be included on the surface. In one embodiment, the SPO<sub>2</sub> sensor can include a reflectance pulse oximetry sensor; in a further embodiment, a transmissive pulse oximetry may be included as part of the SPO<sub>2</sub> sensor. Similarly, a pCO<sub>2</sub> sensor (not shown) to measure blood carbon dioxide level may also be included on the surface. In addition, a respiratory rate sensor can be located on the surface of the non-conductive receptacle **25**. In one embodiment, the respiratory rate sensor can include a strain gauge, with parts of the strain gauge extending beyond the material of the non-conductive receptacle **25** and the flexible backing **20**, and contacting the patient's skin. The respiratory rate sensor can detect patient respiration and may further be able to detect an amplitude of the chest movements during the respiration, which may assist in determining whether respiratory efforts are present during an apneic episode. In one embodiment, the parts of the gauge contacting the skin, the "arms," may be adhered to the skin, making the gauge capable of detecting expansion and contraction of the patient's chest as well as pauses between the chest movements. In a further embodiment, the respiratory rate sensor can include a transthoracic impedance sensor. All of the sensors on the surface can also be located in other parts of the patch **15**.

**[0055]** While the self-contained air flow sensing monitor as shown in FIG. **4** is capable of long-term collection of air flow and ECG data, the monitor can be further modified for an improved air flow monitoring. For example, the extended wear patch may be further modified to provide improved access to sounds of breathing in the patient's trachea. FIG. **17** is a diagram showing, by way of example, a self-contained personal air flow sensing monitor **180** fitted to the sternal region of a female patient **10** in accordance with a further embodiment, with a modified, elongated extended wear electrode patch **181**. The patch **181** includes an elongated tab **182**, the tab **182** extending over the patient's sternal notch **183**. The extended tab **182** reaching over the sternal notch **183** allows improved air flow telemetry detection, with an air flow sensor being placed over the sternal notch **13**. This placement allows

the air flow sensor to detect sounds from the trachea of the patient 10, which may provide improved quality of the air flow telemetry. The monitor recorder 14 stores the recorded air flow telemetry as described supra and infra.

[0056] FIG. 18 is a perspective view showing the extended wear electrode patch with an elongated tab in accordance with one embodiment without the monitor 14 inserted. The length and other dimensions of the extended tab 182 may vary depending on the height of the patient and the tab 182 is of sufficient length to reach the patient's sternal notch 183. The tab 182 can be made of the same material as the flexible backing 190, and be a continuous piece of stretchable material with the backing 190. While shown as having as widening towards a rounded proximal end, other shapes of the tab 182 are also possible. Still other shapes and configurations of the tab 182 are possible.

[0057] An air flow sensor 191, which includes the microphone as described above, can be located near the proximal end of the tab 182, allowing the sensor 191 to detect tracheal breathing sounds through the sternal notch 183. In a further embodiment, the air flow sensor can be located in another part of the tab 182. Other sensors can also be located on extended tab 182, such as a respiratory rate sensor 192, SPO2 sensor 193, and pCO<sub>2</sub> sensor 194. In the embodiment where the respiratory sensor includes a strain gauge, the strain gauge may extend beyond the materials of the tab 182, contacting the patient's skin, and allowing the gauge to measure movements of the patient's chest. In a further embodiment, the other sensors may be collected at other parts of the patch 181, as further described with reference to FIG. 19. The recorded telemetry from the sensors can be transmitted to the electrical pads 195 of the non-conductive receptacle 196 over wiring included in the patch 180, allowing the monitor recorder 14 to receive the telemetry through the electric pads 195 once the monitor recorder is snapped into the non-conductive receptacle 196. The sensors 191-195 can be electrically connected to the battery 197, or be powered from another source. In a further embodiment, the sensors located on the extended tab 182 can be electrically connected to a wireless transceiver (not shown), and can transmit the recorded telemetry over the wireless transceiver to the monitor recorder 14. In the described embodiment, the extended tab 182 can be at least partially covered with adhesive to facilitate the attachment of the patch to the sternal node. Similarly, the parts of the respiratory rate sensor contacting the patient's skin may further be covered with an adhesive. While the extended tab 182 can affect the placement of sensors and the shape of the patch 181, unless otherwise mentioned, configurations and characteristics of the embodiment of the monitor 180 can be the same as described above and below in regards to the embodiment of the self-contained air flow sensing monitor shown with reference to FIG. 4, and the data collected by the embodiment of the monitor 180 can be processed in the same way as the data collected by the embodiment of the monitor shown in FIG. 4.

[0058] As mentioned above, in the electrode patch shown in FIG. 18, respiratory sensors other than the air flow sensor 191 can be included either on the elongated tab 182 or on other parts of the patch 181. FIG. 19 shows an alternative perspective view of the non-conductive receptacle 196 of FIG. 18 in accordance with one embodiment, showing the surface of the non-conductive receptacle 196 that faces the flexible backing 190. The respiratory rate sensor 192, SPO2 sensor 193, and pCO<sub>2</sub> sensor 194 can be located on the surface of the non-conductive receptacle, though other locations for these sen-

sors are also possible. In the embodiment where the respiratory rate sensor 192 is a strain gauge, the arms of the gauge may extend beyond the receptacle 196, contacting the patient's skin and allowing to the movement of the patient's chest.

[0059] The monitor recorder 14 draws power externally from the battery provided in the non-conductive receptacle 25, thereby uniquely obviating the need for the monitor recorder 14 to carry a dedicated power source. FIG. 8 is a bottom plan view of the monitor recorder 14 of FIG. 4. A cavity 58 is formed on the bottom surface of the sealed housing 50 to accommodate the upward projection of the battery compartment 36 from the bottom surface of the non-conductive receptacle 25, when the monitor recorder 14 is secured in place on the non-conductive receptacle 25. A set of electrical contacts 56 protrude from the bottom surface of the sealed housing 50 and are arranged in alignment with the electrical pads 34 provided on the bottom surface of the non-conductive receptacle 25 to establish electrical connections between the electrode patch 15 and the monitor recorder 14. In addition, a seal coupling 57 circumferentially surrounds the set of electrical contacts 56 and securely mates with the moisture-resistant seal 35 formed on the bottom surface of the non-conductive receptacle 25. In the further embodiment where the air flow sensor 42 is located on the monitor recorder 14, the air flow sensor 42 can also be located on the bottom surface, though other locations are possible.

[0060] The placement of the flexible backing 20 on the sternal midline 16 (or immediately to either side of the sternum 13) also helps to minimize the side-to-side movement of the wearable monitor 12 in the left- and right-handed directions during wear. To counter the dislodgment of the flexible backing 20 due to compressional and torsional forces, a layer of non-irritating adhesive, such as hydrocolloid, is provided at least partially on the underside, or contact, surface of the flexible backing 20, but only on the distal end 30 and the proximal end 31. As a result, the underside, or contact surface of the longitudinal midsection 23 does not have an adhesive layer and remains free to move relative to the skin. Thus, the longitudinal midsection 23 forms a crimp relief that respectively facilitates compression and twisting of the flexible backing 20 in response to compressional and torsional forces. Other forms of flexible backing crimp reliefs are possible.

[0061] Unlike the flexible backing 20, the flexible circuit 32 is only able to bend and cannot stretch in a planar direction. The flexible circuit 32 can be provided either above or below the flexible backing 20. FIG. 9 is a top view showing the flexible circuit 32 of the extended wear electrode patch 15 of FIG. 4 when mounted above the flexible backing 20. A distal ECG electrode 38 and proximal ECG electrode 39 are respectively coupled to the distal and proximal ends of the flexible circuit 32. A strain relief 40 is defined in the flexible circuit 32 at a location that is partially underneath the battery compartment 36 when the flexible circuit 32 is affixed to the flexible backing 20. The strain relief 40 is laterally extendable to counter dislodgment of the ECG electrodes 38, 39 due to tensile and torsional forces. A pair of strain relief cutouts 41 partially extend transversely from each opposite side of the flexible circuit 32 and continue longitudinally towards each other to define in 'S'-shaped pattern, when viewed from above. The strain relief respectively facilitates longitudinal extension and twisting of the flexible circuit 32 in response to tensile and torsional forces. Other forms of circuit board strain relief are possible.

**[0062]** ECG monitoring and other functions performed by the monitor recorder **14** are provided through a micro controlled architecture. FIG. **10** is a functional block diagram showing the component architecture of the circuitry **60** of the monitor recorder **14** of FIG. **4**. The circuitry **60** is externally powered through a battery provided in the non-conductive receptacle **25** (shown in FIG. **6**). Both power and raw ECG signals, which originate in the pair of ECG electrodes **38, 39** (shown in FIG. **9**) on the distal and proximal ends of the electrode patch **15**, are received through an external connector **65** that mates with a corresponding physical connector on the electrode patch **15**. The external connector **65** includes the set of electrical contacts **56** that protrude from the bottom surface of the sealed housing **50** and which physically and electrically interface with the set of pads **34** provided on the bottom surface of the non-conductive receptacle **25**. The external connector includes electrical contacts **56** for data download, microcontroller communications, power, analog inputs, and a peripheral expansion port. The arrangement of the pins on the electrical connector **65** of the monitor recorder **14** and the device into which the monitor recorder **14** is attached, whether an electrode patch **15** or download station (not shown), follow the same electrical pin assignment convention to facilitate interoperability. The external connector **65** also serves as a physical interface to a download station **125** that permits the retrieval of stored ECG monitoring data, communication with the monitor recorder **14**, and performance of other functions.

**[0063]** Operation of the circuitry **60** of the monitor recorder **14** is managed by a microcontroller **61**. The microcontroller **61** includes a program memory unit containing internal flash memory that is readable and writeable. The internal flash memory can also be programmed externally. The microcontroller **61** draws power externally from the battery provided on the electrode patch **15** via a pair of the electrical contacts **56**. The microcontroller **61** connects to the ECG front end circuit **63** that measures raw cutaneous electrical signals and generates an analog ECG signal representative of the electrical activity of the patient's heart over time.

**[0064]** The circuitry **60** of the monitor recorder **14** also includes a flash memory **62**, which the microcontroller **61** uses for storing ECG monitoring data and other physiology and information. The flash memory **62** also draws power externally from the battery provided on the electrode patch **15** via a pair of the electrical contacts **56**. Data is stored in a serial flash memory circuit, which supports read, erase and program operations over a communications bus. The flash memory **62** enables the microcontroller **61** to store digitized ECG data. The communications bus further enables the flash memory **62** to be directly accessed externally over the external connector **65** when the monitor recorder **14** is interfaced to a download station.

**[0065]** The circuitry **60** of the monitor recorder **14** further includes an actigraphy sensor **64** implemented as a 3-axis accelerometer. The accelerometer may be configured to generate interrupt signals to the microcontroller **61** by independent initial wake up and free fall events, as well as by device position. In addition, the actigraphy provided by the accelerometer can be used during post-monitoring analysis to correct the orientation of the monitor recorder **14** if, for instance, the monitor recorder **14** has been inadvertently installed upside down, that is, with the monitor recorder **14** oriented on the electrode patch **15** towards the patient's feet, as well as for other event occurrence analyses, such as described in com-

monly-assigned U.S. patent application, entitled "Event Alerting Through Actigraphy Embedded Within Electrocardiographic Data," Ser. No. \_\_\_\_\_, filed \_\_\_\_\_, pending, the disclosure of which is incorporated by reference.

**[0066]** The microcontroller **61** includes an expansion port that also utilizes the communications bus. External devices, such as the air flow sensor **69**, separately drawing power externally from the battery provided on the electrode patch **15** or other source, can interface to the microcontroller **61** over the expansion port in half duplex mode. For instance, an external physiology sensor can be provided as part of the circuitry **60** of the monitor recorder **14**, or can be provided on the electrode patch **15** with communication with the microcontroller **61** provided over one of the electrical contacts **56**. The physiology sensor can include an SpO<sub>2</sub> sensor, a pCO<sub>2</sub> sensor, blood pressure sensor, temperature sensor, glucose sensor, respiratory rate sensor, air flow sensor, volumetric pressure sensing, or other types of sensor or telemetric input sources. For instance, in the embodiment where the air flow sensor **69** is included as part of the monitor recorder **14**, the air flow sensor **69** is incorporated into the circuitry **60** and interfaces the microcontroller **61** over the expansion port in half duplex, and may be configured to generate interrupt signals to the microcontroller **61** when detecting an air flow event, as further discussed infra with reference to FIG. **12**. Similarly, other respiratory sensors such as the SpO<sub>2</sub> sensor, a pCO<sub>2</sub> sensor, and a respiratory rate sensor, can be connected to the microcontroller **61** in the same way and generate an interrupt signal upon detecting a respiratory event. In a further embodiment, a wireless interface for interfacing with other wearable (or implantable) physiology monitors, as well as data offload and programming, can be provided as part of the circuitry **60** of the monitor recorder **14**, or can be provided on the electrode patch **15** with communication with the microcontroller **61** provided over one of the electrical contacts **56**, such as described in commonly-assigned U.S. patent application, entitled "Remote Interfacing of an Extended Wear Electrocardiography and Physiological Sensor Monitor," Ser. No. \_\_\_\_\_, filed \_\_\_\_\_, pending, the disclosure of which is incorporated by reference.

**[0067]** Finally, the circuitry **60** of the monitor recorder **14** includes patient-interfaceable components, including a tactile feedback button **66**, which a patient can press to mark events or to perform other functions, and a buzzer **67**, such as a speaker, magnetic resonator or piezoelectric buzzer. The buzzer **67** can be used by the microcontroller **61** to output feedback to a patient such as to confirm power up and initiation of ECG monitoring. Still other components as part of the circuitry **60** of the monitor recorder **14** are possible.

**[0068]** While the monitor recorder **14** operates under micro control, most of the electrical components of the electrode patch **15** operate passively. FIG. **11** is a functional block diagram showing the circuitry **70** of the extended wear electrode patch **15** of FIG. **4**. The circuitry **70** of the electrode patch **15** is electrically coupled with the circuitry **60** of the monitor recorder **14** through an external connector **74**. The external connector **74** is terminated through the set of pads **34** provided on the bottom of the non-conductive receptacle **25**, which electrically mate to corresponding electrical contacts **56** protruding from the bottom surface of the sealed housing **50** to electrically interface the monitor recorder **14** to the electrode patch **15**.

**[0069]** The circuitry **70** of the electrode patch **15** performs three primary functions. First, a battery **71** is provided in a

battery compartment formed on the bottom surface of the non-conductive receptacle 25. The battery 71 is electrically interfaced to the circuitry 60 of the monitor recorder 14 as a source of external power. The unique provisioning of the battery 71 on the electrode patch 15 provides several advantages. First, the locating of the battery 71 physically on the electrode patch 15 lowers the center of gravity of the overall wearable monitor 12 and thereby helps to minimize shear forces and the effects of movements of the patient and clothing. Moreover, the housing 50 of the monitor recorder 14 is sealed against moisture and providing power externally avoids having to either periodically open the housing 50 for the battery replacement, which also creates the potential for moisture intrusion and human error, or to recharge the battery, which can potentially take the monitor recorder 14 off line for hours at a time. In addition, the electrode patch 15 is intended to be disposable, while the monitor recorder 14 is a reusable component. Each time that the electrode patch 15 is replaced, a fresh battery is provided for the use of the monitor recorder 14, which enhances ECG monitoring performance, quality, and duration of use. Finally, the architecture of the monitor recorder 14 is open, in that other physiology sensors or components can be added by virtue of the expansion port of the microcontroller 61. Requiring those additional sensors or components to draw power from a source external to the monitor recorder 14 keeps power considerations independent of the monitor recorder 14. Thus, a battery of higher capacity could be introduced when needed to support the additional sensors or components without effecting the monitor recorder's circuitry 60.

[0070] In the embodiment where the air flow sensor 75 is a part of the electrode patch 15, the air flow sensor 75 is included as a part of the circuitry 70 and can draw power from the battery 71. In this embodiment, the air flow sensor 75 is connected to the external connector 74, and may be configured to generate interrupt signals to the microcontroller 61 when detecting an air flow event, as further discussed infra with reference to FIG. 12. Other respiratory sensors, such as the SpO<sub>2</sub> sensor, the pCO<sub>2</sub> sensor, and the respiratory rate sensor can be included as part of the circuitry 70 in the same manner as the air flow sensor 69.

[0071] Second, the pair of ECG electrodes 38, 39 respectively provided on the distal and proximal ends of the flexible circuit 32 are electrically coupled to the set of pads 34 provided on the bottom of the non-conductive receptacle 25 by way of their respective circuit traces 33, 37. The signal ECG electrode 39 includes a protection circuit 72, which is an inline resistor that protects the patient from excessive leakage current.

[0072] Last, in a further embodiment, the circuitry 70 of the electrode patch 15 includes a cryptographic circuit 73 to authenticate an electrode patch 15 for use with a monitor recorder 14. The cryptographic circuit 73 includes a device capable of secure authentication and validation. The cryptographic device 73 ensures that only genuine, non-expired, safe, and authenticated electrode patches 15 are permitted to provide monitoring data to a monitor recorder 14, such as described in commonly-assigned U.S. patent application, entitled "Self-Authenticating Electrocardiography Monitoring Circuit," Ser. No. \_\_\_\_\_, filed \_\_\_\_\_, pending, the disclosure which is incorporated by reference.

[0073] The monitor recorder 14 continuously monitors the patient's heart rate and physiology. FIG. 12 is a flow diagram showing a monitor recorder-implemented method 100 for

monitoring ECG and air flow data for use in the monitor recorder 14 of FIG. 4. Initially, upon being connected to the set of pads 34 provided with the non-conductive receptacle 25 when the monitor recorder 14 is snapped into place, the microcontroller 61 executes a power up sequence (step 101). During the power up sequence, the voltage of the battery 71 is checked, the state of the flash memory 62 is confirmed, both in terms of operability check and available capacity, and microcontroller operation is diagnostically confirmed. In a further embodiment, an authentication procedure between the microcontroller 61 and the electrode patch 15 are also performed.

[0074] Following satisfactory completion of the power up sequence, an iterative processing loop (steps 102-109) is continually executed by the microcontroller 61. During each iteration (step 102) of the processing loop, the ECG frontend 63 (shown in FIG. 10) continually senses the cutaneous ECG electrical signals (step 103) via the ECG electrodes 38, 29 and is optimized to maintain the integrity of the P-wave. A sample of the ECG signal is read (step 104) by the microcontroller 61 by sampling the analog ECG signal output front end 63. FIG. 12 is a graph showing, by way of example, a typical ECG waveform 110. The x-axis represents time in approximate units of tenths of a second. The y-axis represents cutaneous electrical signal strength in approximate units of millivolts. The P-wave 111 has a smooth, normally upward, that is, positive, waveform that indicates atrial depolarization. The QRS complex usually begins with the downward deflection of a Q wave 112, followed by a larger upward deflection of an R-wave 113, and terminated with a downward waveform of the S wave 114, collectively representative of ventricular depolarization. The T wave 115 is normally a modest upward waveform, representative of ventricular depolarization, while the U wave 116, often not directly observable, indicates the recovery period of the Purkinje conduction fibers.

[0075] Sampling of the R-to-R interval enables heart rate information derivation. For instance, the R-to-R interval represents the ventricular rate and rhythm, while the P-to-P interval represents the atrial rate and rhythm. Importantly, the PR interval is indicative of atrioventricular (AV) conduction time and abnormalities in the PR interval can reveal underlying heart disorders, thus representing another reason why the P-wave quality achievable by the self-contained personal air flow sensing monitor described herein is medically unique and important. The long-term observation of these ECG indicia, as provided through extended wear of the wearable monitor 12, provides valuable insights to the patient's cardiac function and overall well-being.

[0076] Each sampled ECG signal, in quantized and digitized form, is temporarily staged in buffer (step 105), pending compression preparatory to storage in the flash memory 62 (step 106). Following compression, the compressed ECG digitized sample is again buffered (step 107), then written to the flash memory 62 (step 108) using the communications bus. Processing continues (step 109), so long as the monitoring recorder 14 remains connected to the electrode patch 15 (and storage space remains available in the flash memory 62), after which the processing loop is exited and execution terminates. Still other operations and steps are possible.

[0077] The monitor recorder 14 also receives data from the air flow sensor 42. The data is received in a conceptually-separate execution thread as part of the iterative processing loop (steps 102-109) continually executed by the microcontroller 61. Patient's air flow is monitored by the air flow sensor

42, and the air flow sensor 42 determines presence of an air flow event, an air flow abnormality potentially indicative of a medical condition, that needs to be recorded as part of the monitoring (step 140). The abnormalities in air flow to be recorded include both interruptions of airflow, such as apneas and hypopneas, as well increased air flow due to, for example, deepening of the patient's breathing during a hyperpnea. The presence of the interruption of air flow can be detected by either a complete lack of a sound of breathing, or, for a partial interruption, by a weakening below a certain threshold of a strength of the sound signal detected. Similarly, when the frequency of breathing sounds becomes greater than a pre-defined threshold, an increased air flow can be detected. Other techniques to detect air flow abnormalities can be used. If the duration of an air flow abnormality exceeds a temporal threshold, the abnormality is determined to be an air flow event (step 140). The temporal threshold can be 10 seconds, which is the length at which an air flow interruption is classified as an apnea or a hypopnea, though other temporal thresholds can be used. If no abnormalities are detected or they do not rise to a level of an air flow event (step 140), the method 100 proceeds to step 109. A detection of an air flow event (140) causes the air flow signal to generate an interrupt signal to the microcontroller 61, triggering further processing of the event as described below. During each iteration (step 102) of the processing loop, if air flow event data is detected (step 140), a sample of the air flow telemetry is read (step 141) by the microcontroller 61 and, if necessary, converted into a digital signal by the onboard ADC of the microcontroller 61. Each air flow event data sample, in quantized and digitized form, is temporarily staged in buffer (step 142), pending compression preparatory to storage in the flash memory subsystem 62 (step 143). Following compression, the compressed air flow data sample is again buffered (step 144), then written to the flash memory 62 (step 145) using the communications bus. Processing continues (step 109), so long as the monitoring recorder 14 remains connected to the electrode patch 15 (and storage space remains available in the flash memory 62), after which the processing loop is exited and execution terminates. Still other operations and steps are possible.

[0078] While the method 100 is described with reference to detecting an air flow event, abnormal physiological events detected by other respiratory sensors, such as the respiratory rate sensor 192, SpO<sub>2</sub> sensor 193, and pCO<sub>2</sub> sensor 194 can be recorded using similar steps. For example, a respiratory rate sensor would detect a respiratory rate event upon the rate of respiration, or the amplitude of movement of the patient's chest during the patient's respiration, rising above or falling below a certain threshold for a certain duration of time. An oxygen level event can be determined upon the patient's blood oxygen level as measured by the SpO<sub>2</sub> 193 sensor rising above or falling below a certain threshold. Similarly, a carbon dioxide level event can be determined upon the carbon dioxide level as measured by the pCO<sub>2</sub> 194 sensor rising above or falling below a certain threshold. Upon the event detection, the event would be processed as described with regards to air flow 141-145 *mutatis mutandis*. Respiratory events collected by these additional respiratory sensors, the respiratory rate sensor 192, the SpO<sub>2</sub> sensor 193, and the pCO<sub>2</sub> sensor 194, further aid a physician interpreting monitoring results in diagnosing an abnormal condition.

[0079] The monitor recorder 14 stores ECG data and other information in the flash memory subsystem 62 (shown in

FIG. 10) using a proprietary format that includes data compression. As a result, data retrieved from a monitor recorder 14 must first be converted into a format suitable for use by third party post-monitoring analysis software. FIG. 14 is a flow diagram showing a method 150 for remote interfacing of a self-contained personal air flow sensing monitor 12 in accordance with one embodiment. The method 150 can be implemented in software and execution of the software can be performed on a download station 125, which could be a programmer or other device, or a computer system, including a server 122 or personal computer 129, such as further described supra with reference to FIG. 3, as a series of process or method modules or steps. For convenience, the method 150 will be described in the context of being performed by a personal computer 136 or other connectable computing device (shown in FIG. 3) as middleware that converts ECG data and other information into a format suitable for use by a third-party post-monitoring analysis program. Execution of the method 150 by a computer system would be analogous *mutatis mutandis*.

[0080] Initially, the download station 125 is connected to the monitor recorder 14 (step 151), such as by physically interfacing to a set of terminals 128 on a paired receptacle 127 or by wireless connection, if available. The data stored on by the monitor recorder 14, including ECG and physiological monitoring data, other recorded data, and other information are retrieved (step 152) over a hard link 135 using a control program 137 ("Ctl") or analogous application executing on a personal computer 136 or other connectable computing device. The data retrieved from the monitor recorder 14 is in a proprietary storage format and each datum of recorded ECG monitoring data, as well as any other physiological data or other information, must be converted, so that the data can be used by a third-party post-monitoring analysis program. Each datum of ECG monitoring data is converted by the middleware (steps 153-159) in an iterative processing loop. During each iteration (step 153), the ECG datum is read (step 154) and, if necessary, the gain of the ECG signal is adjusted (step 155) to compensate, for instance, for relocation or replacement of the electrode patch 15 during the monitoring period. In addition, depending upon the configuration of the wearable monitor 12, other physiological data (or other information), including patient events, such as air flow events, fall, peak activity level, sleep detection, detection of patient activity levels and states and so on, may be recorded along with the ECG monitoring data is read (step 156) and is time-correlated to the ECG monitoring data (step 157). For instance, air flow events recorded by the air flow events recorded by the air flow sensor 42 would be temporally matched to the ECG data to provide the proper physiological context to the sensed event occurrence. Similarly, actigraphy data may have been sampled by the actigraphy sensor 64 based on a sensed event occurrence, such as a sudden change in orientation due to the patient taking a fall. In response, the monitor recorder 14 will embed the actigraphy data samples into the stream of data, including ECG monitoring data, that is recorded to the flash memory 62 by the micro-controller 61. Post-monitoring, the actigraphy data is temporally matched to the ECG data to provide the proper physiological context to the sensed event occurrence. As a result, the three-axis actigraphy signal is turned into an actionable event occurrence that is provided, through conversion by the middleware, to third party post-monitoring analysis programs, along with the ECG record-

ings contemporaneous to the event occurrence. Other types of processing of the other physiological data (or other information) are possible.

**[0081]** Thus, during execution of the middleware, any other physiological data (or other information) that has been embedded into the recorded ECG monitoring data is read (step 156) and time-correlated to the time frame of the ECG signals that occurred at the time that the other physiological data (or other information) was noted (step 157). Finally, the ECG datum, signal gain adjusted, if appropriate, and other physiological data as time correlated are stored in a format suitable to the backend software (step 158) used in post-monitoring analysis.

**[0082]** In a further embodiment, the other physiological data, if apropos, is embedded within an unused ECG track. For example, the SCP-ENG standard allows multiple ECG channels to be recorded into a single ECG record. The monitor recorder 14, though, only senses one ECG channel. The other physiological data can be stored into an additional ECG channel, which would otherwise be zero-padded or altogether omitted. The backend software would then be able to read the other physiological data in context with the single channel of ECG monitoring data recorded by the monitor recorder 14, provided the backend software implemented changes necessary to interpret the other physiological data. Still other forms of embedding of the other physiological data with formatted ECG monitoring data, or of providing the other physiological data in a separate manner, are possible.

**[0083]** Processing continues (step 159) for each remaining ECG datum, after which the processing loop is exited and execution terminates. Still other operations and steps are possible.

**[0084]** The collection of the ECG data as described above, and as described in a commonly assigned U.S. patent application, entitled "Extended Wear Ambulatory Electrocardiography and Physiological Sensor Monitor," Ser. No. 14/080,725, filed Nov. 14, 2013, pending, the disclosure of which is incorporated by reference, allows acquisition of ECG data collected over an extended period of time, and when combined the recording of air flow events, simplifies monitoring for episodes of cardiorespiratory conditions. The data collected by the monitor 12 and downloaded to the download station 125 can be further processed by the application software 130 to correlate the air flow events with ECG and other non-air flow data physiological data, which can be helpful to a physician in diagnosing the patient. FIG. 15 is a flow diagram showing the method 160 for processing data collected by the self-contained personal air flow sensing monitor 12 in accordance with one embodiment. Physiological data that includes the identified air flow events, and non-air flow data, including the ECG data and, if applicable, data collected by other sensors of the monitor 12, is received by the application software 130 (step 161). The non-air flow physiological data collected approximately concurrently to the airflow events is identified (step 162). The approximately concurrent data can include not only data that was collected at the same time as when the air flow events took place, but also data collected within a specified time interval from a beginning or an end of each of the air flow events. Optionally, the identified concurrent data can be processed to detect other physiological events, such as cardiac arrhythmias, approximately contemporaneous to air flow events (step 163). For example, the sampled ECG signals can be processed to identify a presence of a cardiac arrhythmia that is substantially contemporaneous

to the air flow events. For example, a heart rate in excess of 100 beats per minute (bpm) can indicate a tachyarrhythmia, and temporal intervals where the heart rate exceeds the 100 bpm threshold can be marked as an event indicative of a tachyarrhythmia. Similarly, a heart rate falling below 60 bpm can be indicative of a bradyarrhythmia, and temporal intervals where the patient's heart rate exceeds 60 bpm can be marked as events indicative of a bradyarrhythmia. Similarly, the substantially contemporaneous actigraphy data can also be processed to detect actigraphy events, as further described in detail in commonly-assigned U.S. patent application, entitled "Event Alerting Through Actigraphy Embedded Within Electrocardiographic Data," Ser. No. \_\_\_\_\_, filed \_\_\_\_\_, pending, the disclosure of which is incorporated by reference. Other ways to process the non-air flow data are possible. The occurrence of arrhythmias concurrent with respiratory problems can indicate the diagnosis of serious sleep apnea. While the method 160 is described with reference to processing data from a monitoring that has already concluded, in a further embodiment, the processing can be performed on the air flow monitor 12, and the occurrence of arrhythmias concurrent with respiratory problems can also serve as a source of initiating an alarm system for patient awareness and alerting the patient with an auditory alert or vibratory alert on the monitor itself, such as through the use of the buzzer 67.

**[0085]** Following the optional identification of the contemporaneous data, the type of the air flow event can be detected (step 164), as further described with reference to FIG. 16. Finally, the information about the air flow events and approximately concurrent non-air flow data is output to a user, such as a physician, such as through a screen of a personal computer 129 (step 165). The output information can include the time the events occurred, the duration of the events, the nature of the event (interruption of air flow or an increased air flow), the magnitude of the air flow abnormality during the event, the type of the event, as well as information about the identified concurrent non-air flow physiological data. In a further embodiment, the sounds recorded during the events, such as snoring can also be output. Any events identified based on the non-air flow data can also be output to the user. In a further embodiment, non-air flow physiological data that is not substantially contemporaneous to the air flow events is also output to the user.

**[0086]** Identification of a type of an air flow event can provide further help to the physician interpreting the results in diagnosing the patient. FIG. 16 is a flow diagram showing a routine 170 for identifying a type of an air flow event for use in the method 160 of FIG. 15. As sleep apnea air flow events occur during a patient's sleep or upon awakening, when respiration resumes, whether the patient was asleep during or immediately prior to an air flow event is important to diagnosing sleep apnea. Whether the patient was asleep approximately concurrently to an air flow event, which includes the period of time during the event or in a predefined temporal interval before the event, is determined by the application software 130 (step 171). The determination can be made using the data collected by the actigraphy sensor 64, which monitors the patient's posture and movement rate. When the actigraphy sensor 64 data shows that the patient assumed a recumbent position and the patient's movement rate has fallen below a predefined threshold, the application software 130 can determine that the patient has fallen asleep. Other physiological data can also be used to determine if the patient

is asleep. For example, falling asleep is characterized by a gradual decrease of the patient's heart rate. By obtaining an average of the heart rate of the patient when the patient is awake, either by analyzing the ECG data and other physiological data collected during the monitoring or from another source, the application software 130 can mark a gradual decline in heart rate from that level as the patient falling asleep. Other ways to determine whether the patient is asleep are possible. If the event occurs when the patient is not asleep and has not been within the predefined temporal period before the event (step 171), the event is determined as not indicative of a sleep apnea condition (step 172), and the routine 170 ends. If the patient is asleep during the event (step 171), the application software 130 determines the event to be indicative of a sleep apnea condition (step 173). The application further determines whether respiratory efforts are associated with the event (step 174). For apneic or hypopneic events, the association is present when the event is accompanied by respiratory efforts. For hyperpneic events, the association is present when the hyperpneic event was preceded within a predefined time interval by an apneic or hypopneic event accompanied by respiratory efforts. The presence of respiratory efforts can be determined using the data collected the respiratory rate sensor 192 or the actigraphy sensor 64, with the presence of chest movements during an air flow event being indicative of respiratory efforts. In a further embodiment, the respiratory efforts can be detected based on data collected by an impedance pneumograph included as one of the physiological sensors of the monitor 12, which can detect chest movements. Other ways to determine the presence of the respiratory efforts are possible.

[0087] If the respiratory efforts are associated with the event (step 174), the application determines the event type to be indicative of an OSA condition (step 175), terminating the routine 170. If the respiratory efforts are not associated with the event (step 176), the application determines the event to be indicative of a CSA condition (step 175), terminating the routine 150. While the routine 170 is described in relation to a sleep apnea condition, in a further embodiment, the application software can be used to identify other types of respiratory events.

[0088] While the invention has been particularly shown and described as referenced to the embodiments thereof, those skilled in the art will understand that the foregoing and other changes in form and detail may be made therein without departing from the spirit and scope.

1. A self-contained personal air flow sensing monitor recorder, comprising:

a sealed housing adapted to be removably secured into a non-conductive receptacle on a disposable extended wear electrode patch; and

an electronic circuitry comprised within the sealed housing, comprising:

an externally-powered micro-controller operable to execute under micro programmable control and electrically interfaced to one or more respiratory sensors comprising an air flow sensor and at least one of an SpO<sub>2</sub> sensor, a pCO<sub>2</sub> sensor, and a respiratory rate sensor, the one or more respiratory sensors comprised within at least one of the disposable extended wear electrode patch and the sealed housing;

an electrocardiographic front end circuit electrically interfaced to the micro-controller and operable to sense electrocardiographic signals through electro-

cardiographic electrodes provided on the disposable extended wear electrode patch, each of the electrocardiographic electrodes adapted to be positioned axially along the midline of the sternum for capturing action potential propagation; and

an externally-powered flash memory electrically interfaced with the micro-controller and operable to store samples of the electrocardiographic signals and respiratory events comprising physiological events detected by the respiratory sensors.

2. A self-contained personal air flow sensing monitor recorder according to claim 1, further comprising:

a server computer system centrally accessible over a data communications network and operable to receive physiological data comprising the respiratory events and the samples of the electrocardiographic signals and to execute programming code stored in a memory, comprising:

an identification module to identify non-air flow physiological data comprising the samples of the electrocardiographic signals and the respiratory events detected by one of the SpO<sub>2</sub> sensor, the pCO<sub>2</sub> sensor, and the respiratory rate sensor collected approximately concurrently to air flow events; and

an output module to output the air flow events and the identified non-air flow data.

3. A self-contained personal air flow sensing monitor recorder according to claim 2, further comprising at least one of:

a processing module to process non-air flow events and to detect the non-air flow events; and

a type module to determine a type of one of the air flow events based on the physiological data,

wherein the output module outputs at least one of the non-air flow events and the type of the air flow event.

4. A self-contained personal air flow sensing monitor recorder according to claim 3, further comprising:

a respiratory efforts module to determine whether respiratory efforts are associated with the air flow event based on the physiological data; and

a condition module to determine that the air flow event is indicative of one of an obstructive sleep apnea condition and a central sleep condition based on whether the respiratory efforts are associated with the air flow event, wherein the physiological data further comprises at least one of an actigraphy sensor data and respiratory rate events.

5. A self-contained personal air flow sensing monitor recorder according to claim 1, further comprising:

a pair of electrical contacts external to the sealed housing and electrically connected to at least one of the micro-controller and the flash memory;

a battery provided on the disposable extended wear electrode patch; and

a pair of electrical pads external to the disposable extended wear electrode patch and disposed to operatively couple with the pair of the electrical contacts, the electrical pads further electrically interfaced via battery leads to the battery.

6. A self-contained personal air flow sensing monitor recorder according to claim 1, the disposable extended wear electrode patch further comprising:

a flexible backing formed of an elongated strip of stretchable material with a narrow longitudinal midsection and,

- on each end, a contact surface at least partially coated with an adhesive dressing provided as a crimp relief;
  - a tab extending from the flexible backing on which at least one of the respiratory event sensors is comprised;
  - a pair of electrocardiographic electrodes conductively exposed on the contact surface of each end of the elongated strip, respectively;
  - a non-conductive receptacle adhered to an outward-facing surface of the elongated strip and comprising a plurality of electrical pads; and
  - a flexible circuit affixed on each end of the elongated strip as a strain relief and comprising a pair of circuit traces electrically coupled to the pair of the electrocardiographic electrodes and a pair of the electrical pads, at least one of the circuit traces adapted to extend along the narrow longitudinal midsection to serve as the strain relief.
- 7.** A self-contained personal air flow sensing monitor, comprising:
- a disposable extended wear electrode patch comprising:
    - a flexible backing formed of an elongated strip of stretchable material with a narrow longitudinal midsection and, on each end, a contact surface at least partially coated with an adhesive dressing provided as a crimp relief;
    - a pair of electrocardiographic electrodes conductively exposed on the contact surface of each end of the elongated strip;
    - a non-conductive receptacle adhered to an outward-facing surface of the elongated strip and comprising a plurality of electrical pads; and
    - a flexible circuit affixed on each end of the elongated strip as a strain relief and comprising a pair of circuit traces electrically coupled to the pair of the electrocardiographic electrodes and a pair of the electrical pads, at least one of the circuit traces adapted to extend along the narrow longitudinal midsection to serve as the strain relief; and
  - a reusable electrocardiography monitor having a sealed housing adapted to be removably secured into the non-conductive receptacle and comprising:
    - a micro-controller operable to execute under micro programmable control and electrically interfaced to an electrocardiographic front end circuit that is operable to sense electrocardiographic signals through the electrocardiographic electrodes via the pair of the electrical pads;
    - an air flow sensor operable to sense air flow events, the air flow sensor electrically interfaced with the micro-controller over an expansion bus operatively interconnected to the micro-controller; and
    - a flash memory electrically interfaced with the micro-controller and operable to store samples of the electrocardiographic signals and the air flow events.
- 8.** A self-contained personal air flow sensing monitor according to claim 7, further comprising:
- a battery comprised on the disposable extended wear electrode patch and electrically interfaced via battery leads to a pair of the electrical pads; and at least one of:
    - the micro-controller operable to draw power from the battery via the pair of the electrical pads;
    - the flash memory operable to draw power from the battery via the pair of the electrical pads; and
- the air flow sensor operable to draw power from the battery via the pair of the electrical pads.
- 9.** A self-contained personal air flow sensing monitor according to claim 8, further comprising:
- a physiology sensor comprised within one of the disposable extended wear electrode patch and the reusable electrocardiography monitor and operable to sense physiology and to draw power from the battery via the battery leads, the physiology sensor electrically interfaced with the micro-controller over the expansion bus; and
  - the flash memory further operable through the expansion bus to store samples of the physiology sensed by the physiology sensor.
- 10.** An self-contained personal air flow sensing monitor according to claim 9, wherein the physiology sensor is selected from the group comprising an SpO<sub>2</sub> sensor, a pCO<sub>2</sub> sensor, a blood pressure sensor, a temperature sensor, a respiratory rate sensor, a glucose sensor, an air flow sensor, and a volumetric pressure sensor.
- 11.** An self-contained personal air flow sensing monitor according to claim 9, wherein the expansion bus is electrically coupled to at least one of the electrical pads.
- 12.** A self-contained personal air flow sensing monitor according to claim 7, further comprising:
- a server computer system centrally accessible over a data communications network and operable to receive physiological data comprising the air flow events and samples of the electrocardiographic signals and to execute programming code stored in a memory, comprising:
    - an identification module to identify non-air flow physiological data comprising the samples of the electrocardiographic signals collected approximately concurrently to the air flow events; and
    - an output module to output the air flow events and the identified non-air flow data.
- 13.** A self-contained personal air flow sensing monitor according to claim 12, further comprising at least one of:
- a processing module to process non-air flow events and to detect the non-air flow events; and
  - a type module to determine a type of one of the air flow events based on the physiological data,
- wherein the output module outputs at least one of the non-air flow events and the type of the air flow event.
- 14.** A self-contained personal air flow sensing monitor according to claim 13, further comprising:
- a respiratory efforts module to determine whether respiratory efforts are associated with an air flow event based on the physiological data; and
  - a condition module to determine that the air flow event is indicative of one of an obstructive sleep apnea condition and a central sleep condition based on whether the respiratory efforts are associated with the air flow event,
- wherein the physiological data further comprises at least one of an actigraphy sensor data and respiratory rate data.
- 15.** A self-contained personal monitor with a disposable air flow sensing component, comprising:
- a disposable extended wear electrode patch comprising:
    - a flexible backing formed of an elongated strip of stretchable material with a narrow longitudinal midsection and, on each end, a contact surface at least partially coated with an adhesive dressing provided as a crimp relief;

- a pair of electrocardiographic electrodes conductively exposed on the contact surface of each end of the elongated strip, respectively;
  - a non-conductive receptacle adhered to an outward-facing surface of the elongated strip and comprising a plurality of electrical pads; and
  - a flexible circuit affixed on each end of the elongated strip as a strain relief and comprising a pair of circuit traces electrically coupled to the pair of the electrocardiographic electrodes and a pair of the electrical pads, at least one of the circuit traces adapted to extend along the narrow longitudinal midsection to serve as the strain relief; and
- respiratory sensors comprising an air flow sensor and a respiratory rate sensor electrically coupled to at least one of the electrical pads and operable to sense air flow events;
- a reusable electrocardiography monitor having a sealed housing adapted to be removably secured into the non-conductive receptacle and comprising:
    - a micro-controller operable to execute under micro programmable control and electrically interfaced to an electrocardiographic front end circuit that is operable to sense electrocardiographic signals through the electrocardiographic electrodes via the pair of the electrical pads, the micro-controller further electrically interfaced to respiratory event sensors over an expansion bus electrically coupled to the at least one electrical pad;
    - a flash memory electrically interfaced with the micro-controller and operable to store samples of the electrocardiographic signals and the respiratory events comprising air flow events and respiratory rate events.
- 16.** A self-contained personal monitor with a disposable air flow sensing component according to claim **15**, further comprising:
- a server computer system centrally accessible over a data communications network and operable to receive physiological data comprising the air flow events and samples of the electrocardiographic signals and to execute programming code stored in a memory, comprising:
    - an identification module to identify non-air flow physiological data comprising ECG data and the respiratory rate events collected approximately concurrently to the air flow events; and
    - an output module to output the air flow events and the identified non-air flow data.
- 17.** A self-contained personal monitor with a disposable air flow sensing component according to claim **16**, further comprising at least one of:
- a processing module to process non-air flow event and to detect the non-air flow events; and
  - a type module to determine a type of one of the air flow events based on the physiological data, wherein the output module outputs at least one of the non-air flow events and the type of the air flow event.
- 18.** A self-contained personal monitor with a disposable air flow sensing component according to claim **17**, further comprising:
- a respiratory efforts module to determine whether respiratory efforts are associated with an air flow event based on the physiological data; and
  - a condition module to determine that the air flow event is indicative of one of an obstructive sleep apnea condition and a central sleep condition based on whether the respiratory efforts are associated with the air flow event.
- 19.** A self-contained personal monitor with a disposable air flow sensing component according to claim **15**, further comprising:
- an elongated tab extending off the flexible backing and on which at least one of the air flow sensor and the respiratory rate sensor are comprised.
- 20.** A self-contained personal monitor with a disposable air flow sensing component according to claim **19**, further comprising:
- a physiology sensor comprised within one of the disposable extended wear electrode patch and the reusable electrocardiography monitor and operable to sense physiology, the physiology sensor electrically interfaced with the micro-controller over the expansion bus; and
  - the flash memory further operable through the expansion bus to store samples of the physiology sensed by the physiology sensor.
- \* \* \* \* \*

专利名称(译)	自给式个人空气流量传感监视器		
公开(公告)号	<a href="#">US20150087922A1</a>	公开(公告)日	2015-03-26
申请号	US14/082102	申请日	2013-11-15
[标]申请(专利权)人(译)	BARDY诊断		
申请(专利权)人(译)	BARDY诊断, INC.		
当前申请(专利权)人(译)	BARDY诊断, INC.		
[标]发明人	BARDY GUST H BISHEY JON MIKALSON FELIX JASON		
发明人	BARDY, GUST H. BISHEY, JON MIKALSON FELIX, JASON		
IPC分类号	A61B5/0205 A61B5/0408 A61B5/0432 A61B5/03 A61B5/01 A61B5/145 A61B5/11 A61B5/1455 A61B5/00		
CPC分类号	A61B5/02055 A61B5/01 A61B5/03 A61B5/04085 A61B5/04087 A61B5/04325 A61B5/7282 A61B5/1118 A61B5/14532 A61B5/14551 A61B5/4818 A61B5/6823 A61B5/087 A61B5/0006 A61B5/0022 A61B5/021 A61B5/0816 A61B5/14552 A61B5/6832 A61B7/003 G16H40/67		
优先权	61/882403 2013-09-25 US		
其他公开文献	US9364155		
外部链接	<a href="#">Espacenet</a> <a href="#">USPTO</a>		

摘要(译)

生理监测可以通过包括两个部件的可穿戴式监视器来提供，所述两个部件是柔性延长的耐磨电极贴片和可移除的可重复使用的监视记录器。可穿戴式监视器沿着胸骨朝向顶部到底部居中地（在中线）坐在患者的胸部上。可穿戴式监视器在胸骨中线（或者直接在胸骨的任一侧）的位置的放置通过消除在整个监视期间将ECG电极连续地放置在皮肤上的相同点中的要求而有益于延长的磨损。相反，患者可以将电极贴片放置在胸骨的一般区域内的任何地方。通过设置在电极贴片上的电池提供电力，这避免了为了更换电池而打开监视记录器的壳体。监视器还包括用于在ECG监测的同时监测患者的空气流量和呼吸测量的传感器。

