



US010433744B2

(12) **United States Patent**  
**Bojovic et al.**

(10) **Patent No.:** **US 10,433,744 B2**  
(45) **Date of Patent:** **Oct. 8, 2019**

(54) **MOBILE THREE-LEAD CARDIAC MONITORING DEVICE AND METHOD FOR AUTOMATED DIAGNOSTICS**

(58) **Field of Classification Search**  
CPC ..... A61B 5/04012  
See application file for complete search history.

(71) Applicant: **HEARTBEAM, INC.**, Santa Clara, CA (US)

(56) **References Cited**

(72) Inventors: **Bosko Bojovic**, Belgrade (RS); **Ljupco Hadzиеvski**, Belgrade (RS); **Vladan Vukcevic**, Belgrade (RS); **Uros Mitrovic**, Belgrade (RS); **Marjan Miletic**, Boljevac (RS)

U.S. PATENT DOCUMENTS

4,216,780 A 8/1980 Rubel  
4,850,370 A 7/1989 Dower  
(Continued)

(73) Assignee: **HeartBeam, Inc.**, Santa Clara, CA (US)

FOREIGN PATENT DOCUMENTS

(\* ) Notice: Subject to any disclaimer, the term of this patent is extended or adjusted under 35 U.S.C. 154(b) by 157 days.

EP 1659936 A1 3/2005  
WO WO01/70105 A2 9/2001

OTHER PUBLICATIONS

(21) Appl. No.: **15/096,159**

Dower et al.; A clinical comparison of three vcg lead systems using resistance-combining networks; American Heart Journal; 55(4); pp. 523-534; Apr. 1958.

(22) Filed: **Apr. 11, 2016**

(65) **Prior Publication Data**

*Primary Examiner* — Carl H Layno

US 2016/0296132 A1 Oct. 13, 2016

*Assistant Examiner* — Jennifer Ghand

**Related U.S. Application Data**

(74) *Attorney, Agent, or Firm* — Shay Glenn LLP

(60) Provisional application No. 62/145,431, filed on Apr. 9, 2015.

(57) **ABSTRACT**

(51) **Int. Cl.**  
*A61B 5/04* (2006.01)  
*A61B 5/0404* (2006.01)  
(Continued)

Methods and apparatuses, including devices and systems, for remote and detection and/or diagnosis of acute myocardial infarction (AMI). In particular, described herein are handheld devices having an electrode configuration capable of recording three orthogonal ECG lead signals in an orientation-specific manner, and transmitting these signals to a processor. The processor may be remote or local, and it may automatically or semi-automatically detect AMI, atrial fibrillation or other heart disorders based on the analyses of the deviation of the recorded 3 cardiac signals with respect to previously stored baseline recordings.

(52) **U.S. Cl.**  
CPC ..... *A61B 5/0404* (2013.01); *A61B 5/0006* (2013.01); *A61B 5/046* (2013.01); *A61B 5/04011* (2013.01); *A61B 5/04012* (2013.01); *A61B 5/04085* (2013.01); *A61B 5/684* (2013.01); *A61B 5/6823* (2013.01);  
(Continued)

**13 Claims, 9 Drawing Sheets**

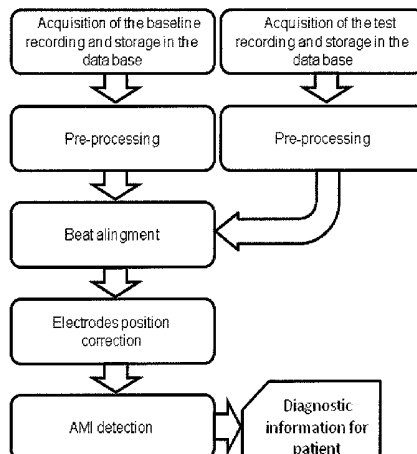



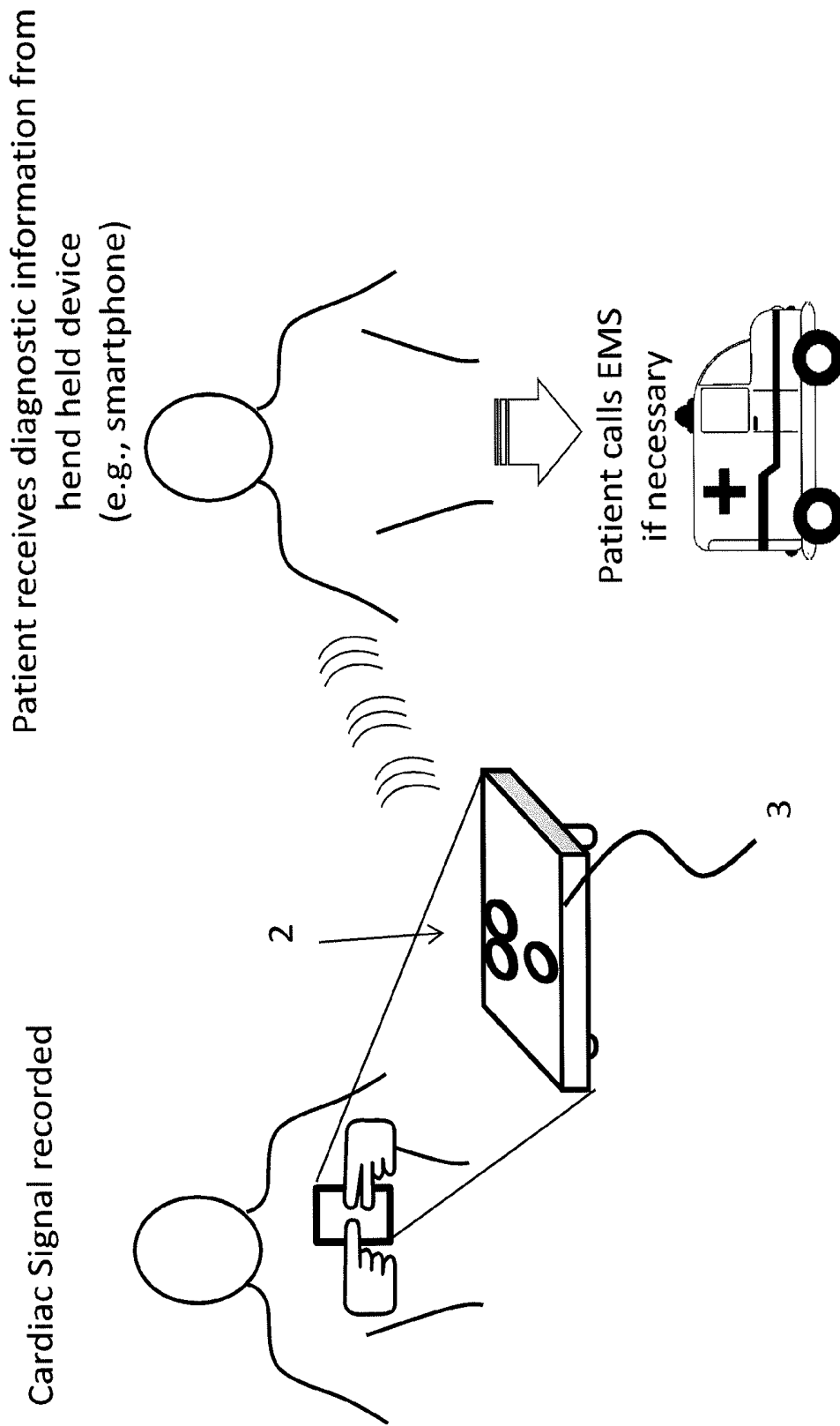

FIG. 1A

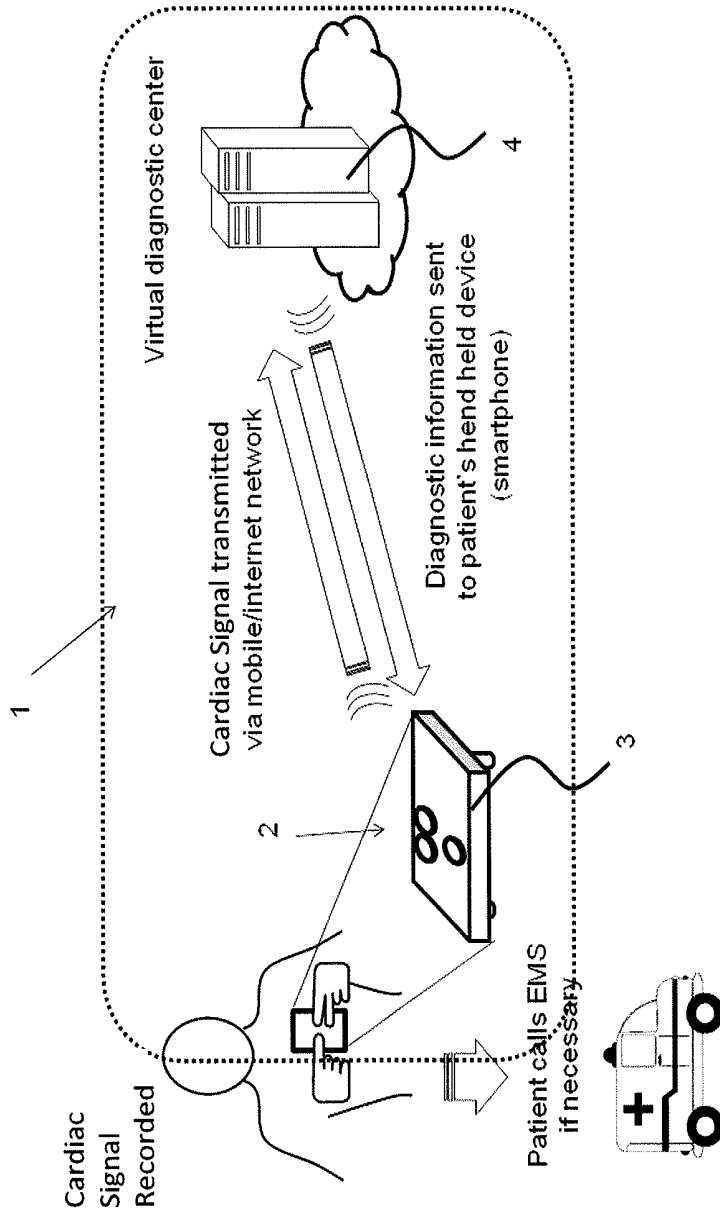

FIG. 1B

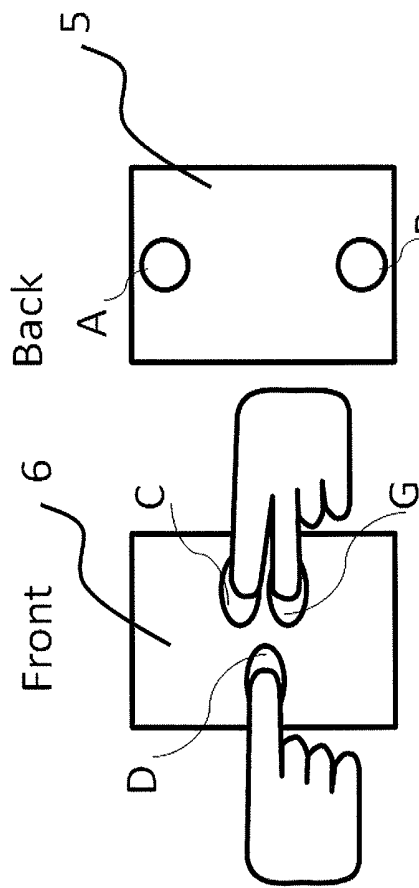

FIG. 2A C G G

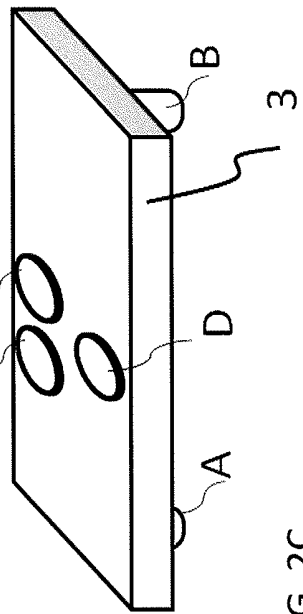

FIG. 2C

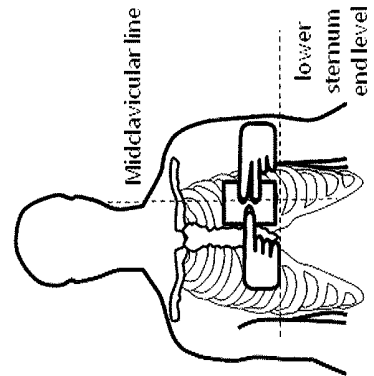

FIG. 2D

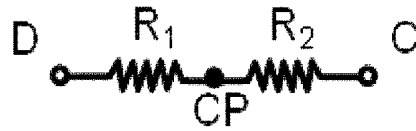

FIG. 3

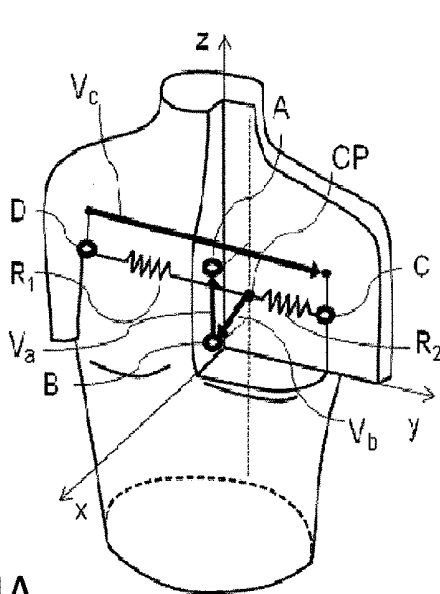

FIG. 4A

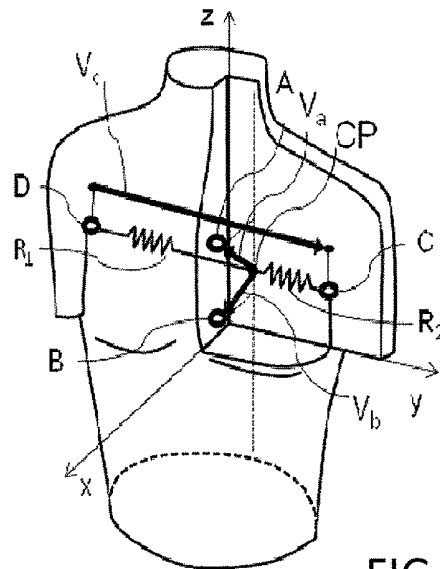

FIG. 4C

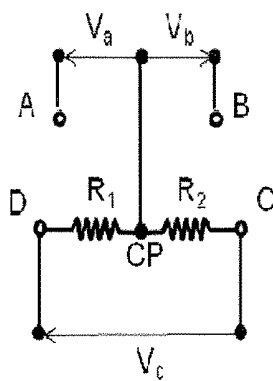

FIG. 4B

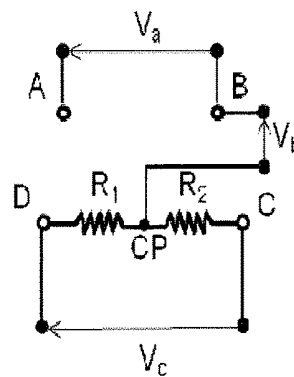

FIG. 4D

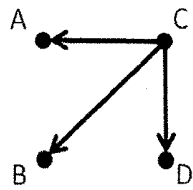

FIG. 4E

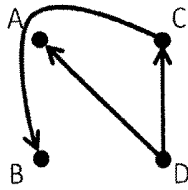

FIG. 4F

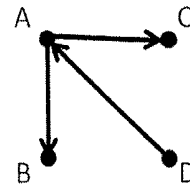
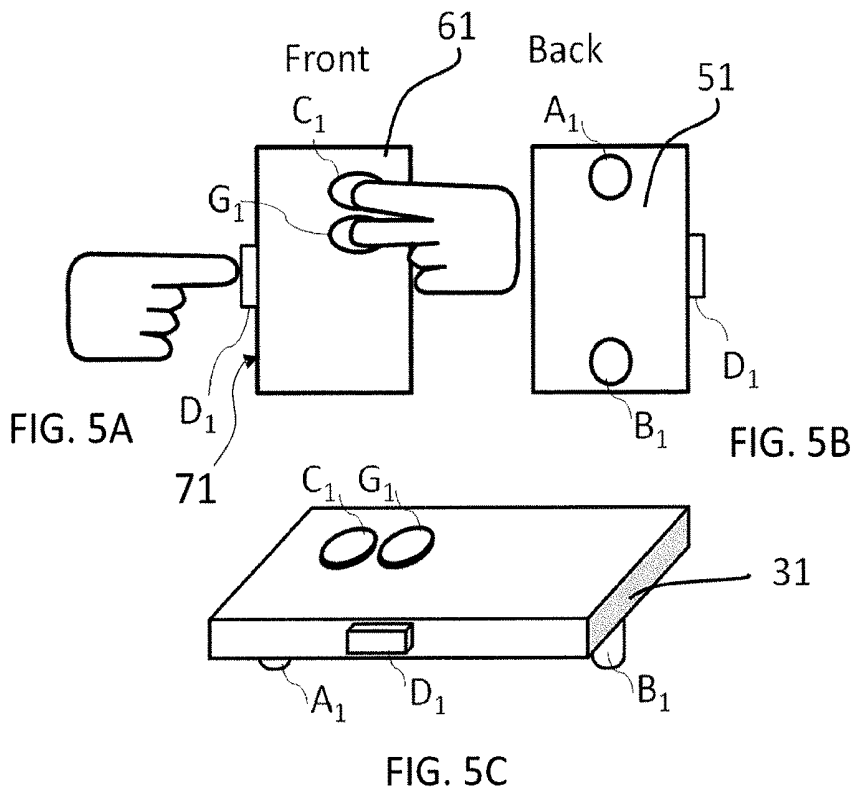

FIG. 4G



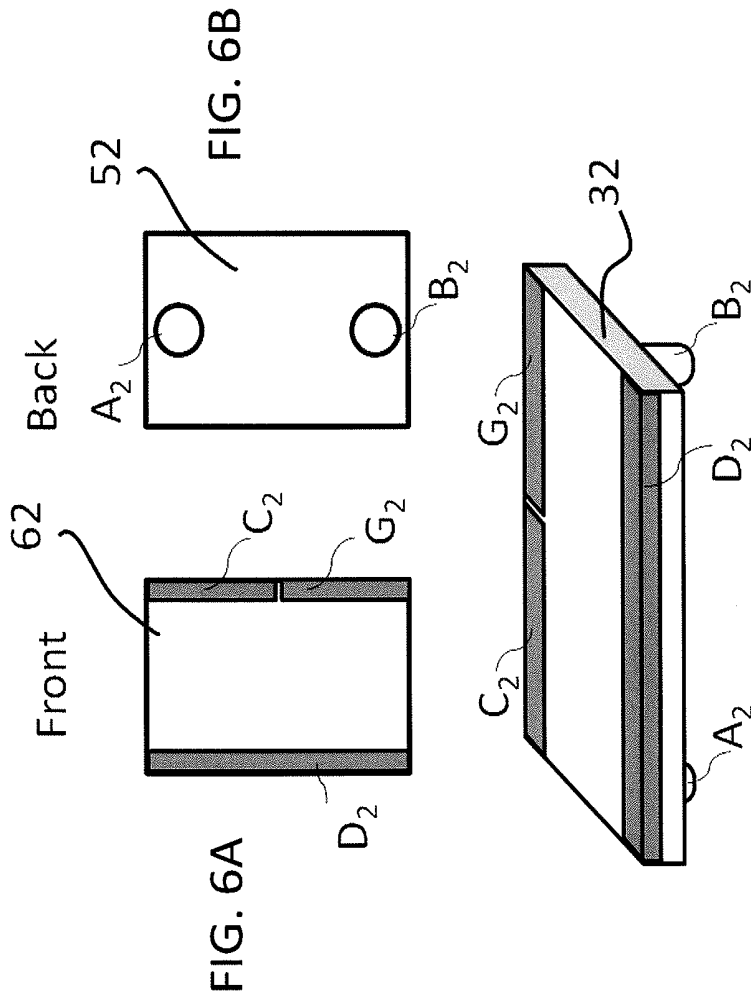

FIG. 6C

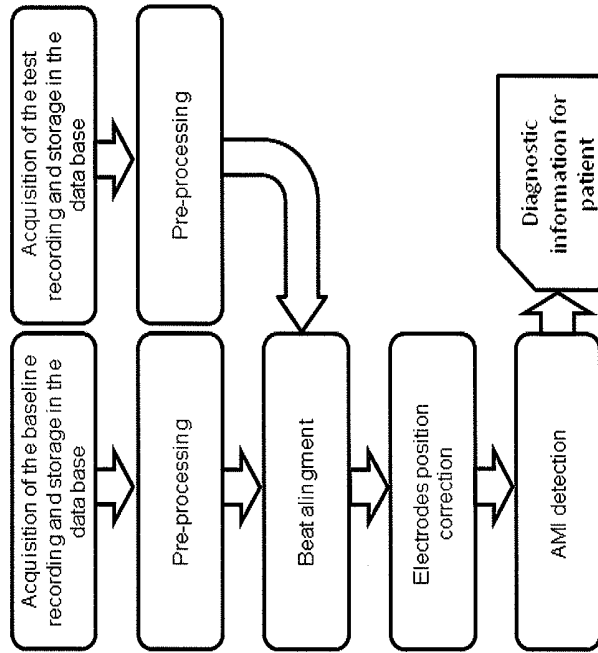

FIG. 8

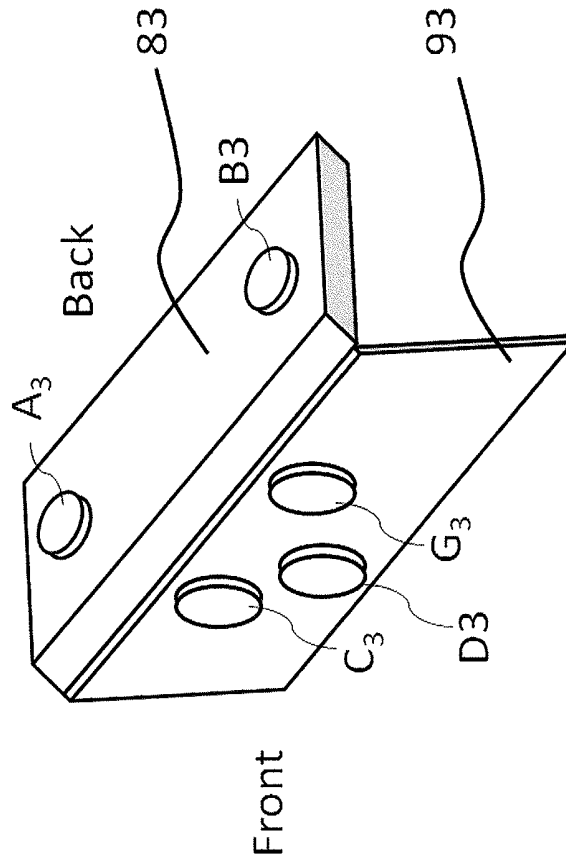

FIG. 7

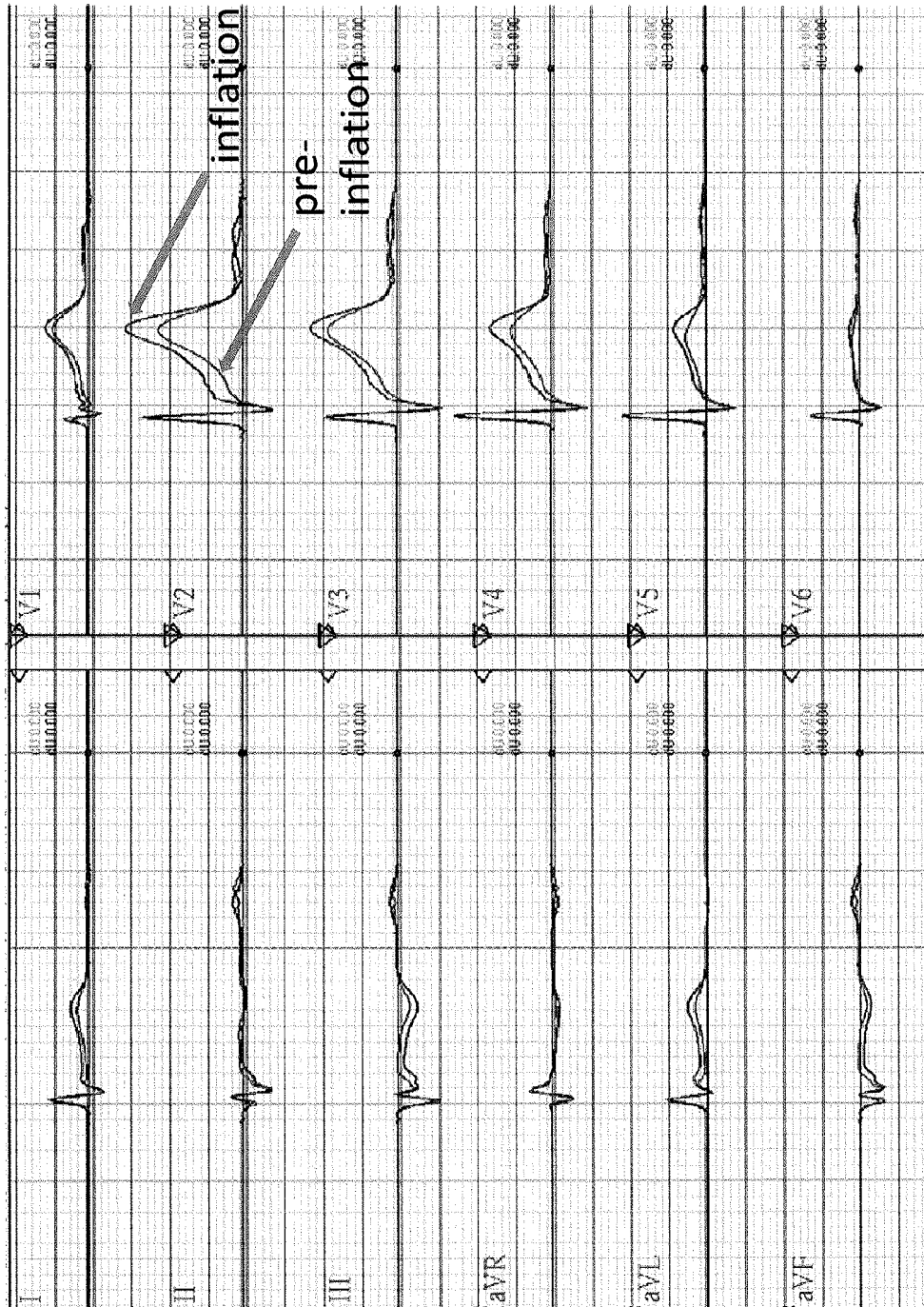

FIG. 9

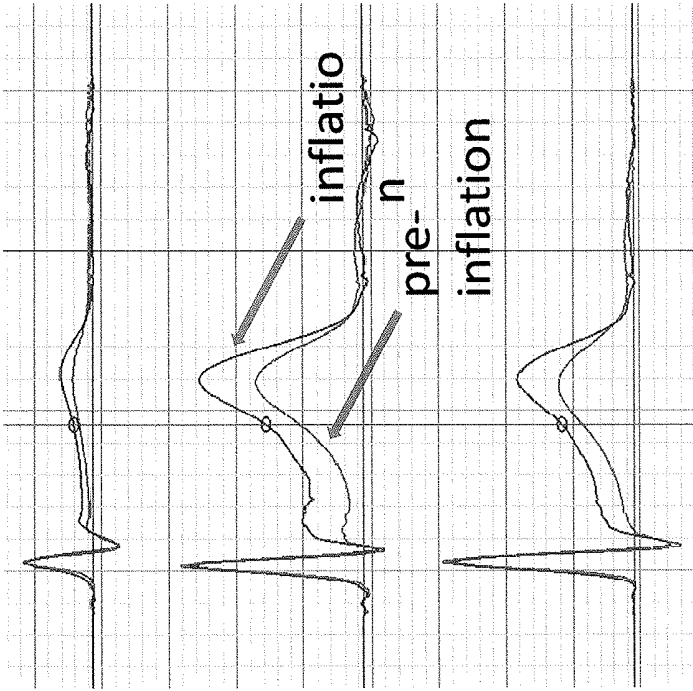

FIG. 10

**MOBILE THREE-LEAD CARDIAC  
MONITORING DEVICE AND METHOD FOR  
AUTOMATED DIAGNOSTICS**

CROSS REFERENCE TO RELATED  
APPLICATIONS

This application claims priority to U.S. Provisional Patent Application No. 62/145,431 titled "MOBILE THREE-LEAD CARDIAC MONITORING DEVICE AND METHOD FOR AUTOMATED DIAGNOSTICS" filed Apr. 9, 2015 which is incorporated herein by reference in its entirety.

INCORPORATION BY REFERENCE

All publications and patent applications mentioned in this specification are herein incorporated by reference in their entirety to the same extent as if each individual publication or patent application was specifically and individually indicated to be incorporated by reference.

Field

Described herein are methods and apparatuses for recording bioelectric signals. More particularly, described herein are hand held apparatuses (devices and systems) for recording, processing and transmitting of ECG data via commercial network to a remote PC computer for automated analysis and generation of information on ECG status and providing feedback information to the handheld device.

Background

Acute Myocardial Infarction (AMI, also referred to as heart attack) remains a leading cause of mortality in the developed world. Finding accurate and cost-effective solutions for AMI diagnosis is vital. Survival of patients having AMI may depend critically on reducing treatment delay, and particularly reducing the time between symptoms onset and medical treatment time. A technology that would enable AMI diagnosis early after occurrence of AMI symptoms, for example, at patient's home or where ever the patient may be, may significantly decrease AMI mortality.

In the AMI setting, the conventional 12-lead ECG is not only the most important piece of information, but it is also nearly as important as all other information combined. Therefore, a technology for early AMI diagnosis may rely on ECG recording. The ECG recording may be performed by the patient himself, but such a technology would need to overcome the problem of complicated application of 12-lead ECG electrodes, and to enable automated software based AMI detection.

Electrocardiogram (ECG) data recording as acquisition of bioelectric signals for cardiac condition status detection is widely known in the art. In general, before the recording is performed, characteristic points on patient's body are identified and electrodes are positioned with respect to these points. During the recording procedure, the electrical voltages between two characteristics points are measured, and corresponding signals are called ECG leads. The conventional ECG uses 10 electrodes to record 12 leads, and the 12 leads ECG (12L ECG) is widely adopted standard in cardiac diagnostics.

It has long been suggested that urgent cardiac diagnostics which enables a patient, wherever he may be, to record his ECU himself and send it to his cardiologist in the remote diagnostic center via commercial telecommunication network (cellular or similar) would be beneficial. On the bases of the received ECG and the conversation with the patient, the cardiologist on duty could decide whether the patient's

state requires urgent medical intervention, and act accordingly. There are a number of patents and products which, within the said concept of urgent cardiac diagnostics, offer different solutions for recording and transmitting the ECG signal. The simplest of these devices uses only a single 'lead' or pair of electrodes. However, devices recording only one ECG lead may be used only for rhythm disorders. Because the ECG changes needed for detection of an AMI may occur in as few as only two among 12 leads of a conventional ECG, it may be difficult, to reliably use only a single lead (or in some cases only a few leads) to reliably and thoroughly detect AMI. Further, it is also unreasonable for a patient to record a full 12L ECG by himself, because of the difficulty in placing the leads.

Solutions capable of detecting AMI that use different surrogates of 12L ECG are also known. For example, Heartview P12 by Aerotel (Aerotel Medical Systems, Holon, Israel), Smartheart, by SHL (SHL Telemedicine, Tel Aviv, Israel) and CardioBip (e.g., U.S. Pat. No. 7,647,093). All these solutions have significant drawbacks. For example, all of these solutions typically require complicated measuring procedures (such as with Heartview, Smartheart), and may require attaching electrodes by the means of cables, taking the clothes off from the waist up, using straps and multi-step recording procedure (e.g., see US20120059271A1 to Amitai et al.). Existing or proposed systems may also require extensive calibration procedures (e.g., Cardiobip), requiring the patient to be in a medical facility with specially trained personnel prior to using the device by himself. Finally, all of these procedures may require medical personnel for interpretation of recorded ECG.

For example, the Cardiobip device is the simplest for use by the patient, and allows simple positioning of the device by pressing it against the chest, with no cables or straps, and recording the ECG. In this example, a diagnostic center may use a PC computer with corresponding software for processing of three special ECG leads and reconstruction of the three leads into a standard 12 lead ECG. The reconstruction is required for interpretation of ECG by the medical personnel. Accuracy of the reconstruction of a 12 standard ECG leads using the recordings of three special leads may be achieved by strictly determined arrangement of integrated electrodes in the mobile device and corresponding leads. A hand-held device may include 5 built in electrodes (see, e.g., EP1659936) three of which may be placed in contact with the chest of the patient and the remaining two electrodes in contact with right and left hand fingers. The reconstruction algorithm in the Cardiobip device is premised on the assumption that the diffuse electric activity of the heart muscle can be approximated by a time-changing electrical dipole (heart dipole) immersed in a low conducting environment. The Heart dipole is represented by a vector defined by three non-coplanar projections, so that it can be determined on the basis of recording of electric potential between any three pairs of points corresponding to three non-coplanar directions, i.e. three special ECG leads not lying on the same plane. Standard ECG leads are reconstructed as linear combinations of the recorded special leads and coefficients by which the transformation matrix is defined. It can be shown, by an in depth analysis, that there are two dominant error sources in such reconstruction. Unfortunately, the heart dipole is only the first term in the multipole mathematical expansion of diffuse heart electrical activity and this approximation is valid only for recording points at a sufficient distance from the heart. In the points near the heart, the linearity of the system necessary for signal reconstruction is

significantly affected by the non-dipole content created due to the presence of higher order terms in multipole expansion.

Further the described reconstruction techniques for converting a few leads into a 12 lead signal for analysis by a cardiologist or other technical expert are also limited. In order to carry enough diagnostic information the three special leads need to be as close to orthogonal as possible (e.g., three vector axis with 90 degrees angle between each of them). The opposite to orthogonal is the case of three coplanar vectors, that is three vectors in the same plane, in which case the diagnostic information corresponding to the axis perpendicular to that plane is completely missing. Importantly the assumptions needed for this modeling, treating the heart as a dipole (and estimating at a distance) and making orthogonal measurements of the heart leads, are at odds with each other, since the orthogonal lead positions are far easier to obtain if the electrodes are closer to the heart, while in this case the non-dipole content is higher. Existing systems such as Cardiobip must rely on the use of a configuration that optimally fulfills both requirements, in which all three leads use the right hand electrode as a reference. These systems also have additional drawbacks. For example, Cardiobip uses three integrated electrodes on the chest side of the device. It was observed in clinical studies using Cardiobip that breast in female patients and pronounced pectoralis muscle in male patients may prevent a reliable contact of all three electrodes with the chest surface simultaneously. It has also been observed that the symmetrical arrangement of finger electrodes on the front side of the device may cause switching of left and right hand fingers in about 10% recordings, making the recording useless for diagnostics.

Similarly, other solutions that use a reduced set of three leads (e.g., US20140163349A1; US20100076331) typically use the three leads that are coplanar and therefore lack enough diagnostic information for AMI detection.

In addition, the requirement for trained medical personnel for the interpretation of recorded ECG may be an organizational challenge and increases the operational cost of the system, and the accuracy of the human ECG interpretation may have large variance. Automated software for ECG interpretation is also used in the systems for early diagnosis of AMI, but they have performance that is inferior to that of human interpreters. The chest pain is the main symptom suggesting an AMI, or ischemia (the underlying physiological process). The main ECG parameter used is the ST segment elevation (STE). Unfortunately, a large number of patients (up to 15%) presenting with chest pain have STE of non-ischemic etiology (NISTE) on their presenting (to the emergency room) ECG. Thus, both human readers and automated software may often misinterpret NISTE as a new STE due to ischemia. In a typical emergency room (ER) scenario, patients with chest pain are examined by emergency physician who must promptly decide if the acute ischemia is present, relaying just on the on-site (current) ECG recording.

Thus, it would be advantageous to provide a technology capable of separating new from old STE, as it could significantly increase performance of automated AMI detection, and make it a viable enhancement or even replacement for human interpretation, particularly when qualified human interpretation is not available. Described herein are methods and apparatuses that may address the problems and needs discussed above, particularly the need for early automated remote diagnostics of AMI. In particular the methods and apparatuses described herein may provide a mechanically

stable and improved electrical contact, while eliminating errors associated with switching of finger contacts.

#### SUMMARY OF THE DISCLOSURE

In general, described herein are methods and apparatuses for recording and analyzing cardiac signals to automatically detect one or more indicators of cardiac dysfunction, including in particular AMI. These apparatuses may typically include a housing having at least four electrodes arranged thereon in an asymmetric manner on two or more surfaces to provide orthogonal, or quasi-orthogonal leads.

As used herein, a cardiac signal may refer to a voltages produced by a human heart as sensed between selected points on the surface of a subject's body, and may also be referred to as cardiac electrical signals (e.g., electrocardiac signals). These cardiac signals may include electrocardiogram (ECG) signals. It should be understood that although the term ECG (electrocardiogram) is commonly used to refer to conventional 12-lead ECG signals, the cardiac signals (cardiac electrical signals) described herein are not limited to these conventional 12-lead ECG signals. Further, although the disclosure herein may use and refer to terms including characteristic points (such as P, Q, R, S, T) and intervals (such as ST segment) on the cardiac signals described, these characteristic points may refer to points, positions or regions equivalent to the positions on conventional 12-lead ECG signals.

Described herein are mobile, hand-held apparatuses for automated cardiac electrical signal analysis. For example, an apparatus may include: a housing having a back, a first side, and a front; a first electrode and a second electrode integrated on the back of the housing configured to measure bioelectric signals from a patient's chest, wherein the first and second electrode are positioned a distance of at least 5 cm apart; a third electrode configured to measure bioelectric signals from the patient's right hand; a fourth electrode configured to measure bioelectric signals from the patient's left hand; wherein one or both of the third electrode and the fourth electrode are integrated on the front of the housing; and a processor within the housing configured to record three orthogonal cardiac leads from the first, second, third and fourth electrodes, wherein less than three pairs of said electrodes comprise the third electrode.

Alternatively or additionally, any of these apparatuses may include: a housing having a back, a first side, and a front; a first electrode and a second electrode integrated on the back of the housing configured to measure bioelectric signals from a patient's chest, wherein the first and second electrode are positioned a distance of at least 5 cm apart; a third electrode configured to measure bioelectric signals from the patient's right hand; a fourth electrode configured to measure bioelectric signals from the patient's left hand; and a processor configured to record 3 orthogonal cardiac leads from the first, second, third and fourth electrodes, wherein the processor comprises a register configured to store a first set of three orthogonal cardiac leads taken at a first time, and a comparator configured to determine a difference signal between the first set of three orthogonal cardiac leads and a second set of three orthogonal cardiac leads taken at a second time.

For example, described herein are mobile, hand-held, three-lead apparatuses for automated electrical cardiac-signal analysis. An apparatus may include: a housing having a back, a first side, and a front, wherein the front is parallel with the back; a first electrode and a second electrode integrated on the back of the housing configured to measure

bioelectric signals from a patient's chest, wherein the first and second electrode are positioned a distance of at least 5 cm apart; a third electrode configured to measure bioelectric signals from the patient's right hand; a fourth electrode configured to measure bioelectric signals from the patient's left hand; wherein one or both of the third electrode and the fourth electrode are integrated on the front of the housing; a resistive network connecting at least two of the first, second, third and fourth electrodes, wherein the resistive network forms a central point (CP); a processor within the housing configured to record 3 orthogonal, or quasi-orthogonal cardiac leads from the first, second, third and fourth electrodes, wherein less than three pairs of said electrodes comprise the third electrode; and a communication circuit within the housing configured to transmit the 3 cardiac leads to an internal or remote processor.

At least one lead may be formed between one of the said electrodes and the central point (CP) formed by mutually connecting at least two electrodes by the resistive network. For example, the third and fourth (right and left hand) electrodes may be separated by a resistive network to form a central point so that at least one lead including the third and fourth electrodes may be measured between the central point and the third or fourth electrode.

In general, the apparatus may be oriented, e.g., including an up and down, relative to the patient's body. The apparatus may include a marker (e.g., one or more of: alphanumeric marker, e.g., label, body shape, light, e.g., LED, etc.). For example, the apparatus may include a marker on the housing indicating the orientation of the housing, such as an LED marker on the housing indicating the orientation of the housing.

The third and fourth electrodes may be disposed on two opposed sides with respect to a longitudinal plane of symmetry of the device housing, said plane of symmetry being substantially perpendicular to the back surface of the device housing.

In any of these variations, a ground electrode may be present on the housing for contacting one of the patient's hands disposed on either the side or front of the housing.

Either the third or fourth electrodes may be band-shaped and disposed along the side of the device housing.

The housing may comprise a mobile phone housing, whereby the third or fourth electrodes are configured as conductive transparent areas on the touch screen of the mobile phone. The housing may be incorporated in a mobile phone housing. The housing may be an extension structure of a mobile phone housing communicating with the said phone using an electrical connector or wireless communication. The housing may form a mobile phone protective case. For example, the housing may form a mobile phone protective case with a phone display protective cover and the third and fourth electrodes incorporated in the phone display protective cover.

In some variations, the apparatus is integrated with or connected to a cover (e.g., back cover) of a mobile phone. For example the housing for the apparatus may be a back cover for a mobile phone that can be retrofitted (e.g., used to replace) a standard back cover of a smartphone or other mobile phone. In some variations, the apparatus can be connected to the cover (e.g., back cover) of the mobile phone, e.g., by an adhesive or other attachment mechanism.

Also described herein are methods of detecting cardiac anomalies, such as detecting ischemia, atrial fibrillation or other cardiac disorder; these methods may be automated methods. Any of these methods may be methods for automated cardiac diagnostics, and may include: acquiring a first

set of at least three orthogonal leads from a patient's chest and hands at a first time; acquiring a second set of at least three orthogonal leads from the patient's chest and hands a second time; performing a beat alignment in a processor on the first and second sets of at least three orthogonal leads to synchronize representative beats from the first and second sets of at least three orthogonal leads; calculating a difference signal representing the change between the first and second at least three orthogonal leads; detecting cardiac changes suggestive of a cardiac condition by comparing parameters of the first and second at least three orthogonal leads or by comparing parameters of the difference signal to a predefined threshold; and communicating cardiac changes from the device to the patient.

Alternatively or additionally, a method for automated cardiac diagnostics may include: positioning a device configured to detect at least three orthogonal leads from a patient's chest and hands against the subject's chest in a first recording position; acquiring a first set of at least three orthogonal leads from the device at a first time; communicating the first set of at least three orthogonal leads to a processor; positioning the device against the subject's chest in a second recording position; acquiring a second set of at least three orthogonal leads from the patient using the device at a second time; communicating the second set of at least three orthogonal leads to the processor; performing a beat alignment in the processor to synchronize representative beats from the first and second sets of at least three orthogonal leads; calculating a difference signal representing the change between the first and second sets of at least three orthogonal leads; detecting cardiac changes suggestive of a cardiac condition by comparing one or more parameters of the difference signal to a predefined threshold; and communicating cardiac changes from the device to the patient.

For example, a method for automated cardiac diagnostics may include: placing a device comprising a housing having four integrated electrodes arranged to measure three orthogonal leads from a patient's chest and hands against the subject's chest in a first recording position; acquiring a first 3 lead cardiac recording (also referred to as three cardiac lead recording and three lead electrical cardiac readings) from the device at a first time (e.g., taking a baseline recordings); communicating the first 3 lead recording to a processor; keeping the device at the same first recording position or placing the device against the subject's chest in a second recording position; acquiring a second 3 lead recording from the device at a second time (diagnostic recordings); communicating the second 3 lead recording to the processor; performing a beat alignment in the processor to synchronize representative beats from the first and second 3 lead recordings; calculating a difference signal representing the change between the first and second 3 cardiac leads recordings; detecting changes in the cardiac signals (e.g., changes in the cardiac signal records, also referred to herein as cardiac changes) suggestive of cardiac conditions, such as ischemia or atrial fibrillation, by comparing parameters of the first and second 3 lead cardiac recording or by comparing parameters of the difference signal to a predefined threshold; and communicating any cardiac changes suggestive of a cardiac condition from the device to the patient.

The first and second recording positions may be different or the same. In some variations, the method (or an apparatus performing the method) may detect if the positions have changed and either correct for the different recording positions or indicate that the hand-held device needs to be more accurately repositioned. For example, the method may include compensating for chest electrode miss-positioning

between the first and second recording positions in the processor by compensating a heart electrical axis deviation in a 3 cardiac leads vector space.

Communicating the first 3 lead electrical cardiac recording to the processor may comprise wirelessly transmitting the first 3 lead electrical cardiac recordings to a remote processor, transmitting a partial cardiac-recording processing result to a remote processing, or just transferring the 3-lead cardiac recordings to an internal processor for processing, or for patient alert.

In general, these methods may include pre-processing the first and second 3 lead electrical cardiac recordings in the processor to achieve one or more of: eliminate power line interference, baseline wandering and/or muscle noise; obtain a representative beat using fiducial points and median beat procedure; and check for switching of the left and right finger.

The parameters of the diagnostic recording, baseline recording and difference signal may be vector magnitude of the cardiac signal, where the vector components are three cardiac leads of the diagnostic, baseline and difference signals in a single time instant (J point, J+80 ms) or average in predetermined time interval (e.g., the ST segment or other predetermined interval) and radius of the sphere which envelopes the vector signal hodograph of the ST segment (or other predetermined interval).

The parameters of the diagnostic recording, baseline recording and difference signal may be RR variability (or equivalent), amplitude of P waves (or equivalent), or averaged amplitude of P waves when detection of atrial fibrillation or atrial flutter are desired.

Any of these methods may also include transmitting any cardiac signal changes suggestive of a cardiac condition from the processor to the device. The methods may also include communicating any cardiac signal changes suggestive of a cardiac condition from the device to the patient comprises presenting a visual and/or audible alert to the patient.

For example, a method for automated cardiac diagnostics may include: placing a device comprising a housing having four integrated electrodes arranged to measure three orthogonal, or quasi-orthogonal, leads from a patient's chest and hands against the subject's chest in a first recording position; acquiring a first 3 lead cardiac recording from the device at a first time; communicating the first 3 lead cardiac recording to a processor; storing the first 3 lead cardiac recording as baseline recording; keeping the device at the same first location, or placing the device against the subject's chest in a second recording position; acquiring a second 3 lead cardiac recording from the device at a second time; communicating the second 3 lead cardiac recording to the processor; pre-processing the first and second 3 lead cardiac recordings in the processor to eliminate power line interference, baseline wandering and muscle noise, obtain a representative beat using fiducial points and median beat procedure, and to check for switching of the left and right finger; performing beat alignment in the processor to bring representative beats from the first and second 3 lead cardiac recordings in a same time frame so that corresponding points are synchronized; compensating for chest electrode mispositioning between the first and second recording positions in the processor by compensating a heart electrical axis deviation in a 3 cardiac leads vector space; calculating a difference signal representing the change between the first and second 3 cardiac leads recordings; detecting cardiac signal changes suggestive of cardiac condition (e.g. ischemia, atrial fibrillation, atrial flutter, etc.) by comparing

parameters of the first and second 3 lead cardiac recording or by comparing parameters of the difference signal to a predefined threshold; communicating any cardiac signal changes suggestive of a cardiac condition from the device to the patient.

In general, described herein are apparatuses configured to perform any of the methods described herein. For example, an apparatus configured to provide an automated cardiac diagnostics may include: a housing comprising at least four electrodes connected to a processor within the housing; wherein the processor is configured to: acquire a first set of at least three orthogonal leads from a patient's chest and hands at a first time; acquire a second set of at least three orthogonal leads from the patient's chest and hands a second time; perform a beat alignment on the first and second sets of at least three orthogonal leads to synchronize representative beats from the first and second sets of at least three orthogonal leads; calculate a difference signal representing the change between the first and second at least three orthogonal leads; detect cardiac changes suggestive of a cardiac condition by comparing parameters of the first and second at least three orthogonal leads or by comparing parameters of the difference signal to a predefined threshold; and communicate cardiac changes from the device to the patient.

Although the description of the methods and apparatuses included herein describes the use of a set of orthogonal, or quasi-orthogonal, cardiac signals, these methods and apparatuses may be used with any set of signals (cardiac electrical signals) which contain significant independent cardiac information. For example, an implementation that used cardiac leads represented by vectors that are not completely orthogonal would not deviate from the spirit of this invention. It would be important to have the respective cardiac vectors orientated at relative angles greater than 30° with respect to one another. Such smaller relative angles may still provide significantly linearly independent information and allow the apparatuses and methods described herein to produce similar and clinically/diagnostically relevant results. Accordingly, for simplicity, without implying any limitation, we may herein refer to our cardiac leads as orthogonal leads. Thus, orthogonal leads may be strictly orthogonal (e.g., having deviation of the leads relative angles from 90° less than 10°, less than 8°, less than 7°, less than 6°, less than 5°, less than 4°, less than 3°, less than 2°, less than 1°, etc.) or approximately orthogonal (e.g., having deviation of the leads relative angles from 90° less than 30°, 25°, 20°, 15°, etc.). Alternatively, the quasi-orthogonality can be assessed based on the cross-correlation function of combinations of data from any two leads, data which were required at about the same time and with the same device. Given that herein orthogonality refers to the amount of independent information content, two leads from the set may be deemed quasi-orthogonal if their cross-correlation is less than 0.6.

#### BRIEF DESCRIPTION OF THE DRAWINGS

FIG. 1A shows one variation of a schematic configuration of a diagnostic system for detection of cardiac disorders such as AMI, including a local processor in the system.

FIG. 1B is another schematic of a remote diagnostic system, wherein the processor is remote from the hand-held device.

FIG. 2A shows a front (non-chest) view of one variation of a handheld device with two recording and one ground electrode.

FIG. 2B shows a back (chest) view of one variation of a handheld device with two recording electrodes.

FIG. 2C shows an axonometric view of a handheld device.

FIG. 2D shows a front view of the device placed against the patient's body in a recording position.

FIG. 3 shows a simple electrical scheme for obtaining a central point CP by connecting the electrodes of both hands via a simple resistive network with two resistors.

FIG. 4A shows schematic configuration of the three cardiac leads measured on the torso with one lead using central point as the reference pole—the preferred embodiment.

FIG. 4B shows an electrical circuit of the three cardiac leads with one lead using central point as the reference pole.

FIG. 4C shows a schematic configuration of the three cardiac leads measured on the torso with two leads using central point as the reference pole.

FIG. 4D is an electrical circuit of the three cardiac leads with two leads using central point as the reference pole.

FIGS. 4E, 4F and 4G show schematic diagrams of three possible configurations for measuring 3 leads among two chest and two hand electrodes.

FIG. 5A shows a front (non-chest) view of the handheld device with two front and one side electrode.

FIG. 5B shows a back (chest) view of the handheld device with two front and one side electrode.

FIG. 5C shows an axonometric view of the handheld device with two front and one side electrode.

FIG. 6A is a front (non-chest) view of the handheld device with electrodes on the edges of the device.

FIG. 6B is a back (chest) view of the handheld device with electrodes on the edges of the device.

FIG. 6C is an axonometric view of the handheld device with electrodes on the edges of the device.

FIG. 7 is an axonometric view of the handheld device realized as a flip case attachable to a mobile phone.

FIG. 8 shows a flow chart of the method for detecting AMI.

FIG. 9 shows one example of a patient with BER (Benign Early Repolarization), showing median beats in 12 leads. Both pre-inflation and inflation recordings show ST segment elevation in precordial leads, which is typically problematic for a human reader to distinguish ischemic from non-ischemic recording.

FIG. 10 is an example of a patient with BER (Benign Early Repolarization), showing median beats in 3 special leads. The signal difference between pre-inflation and inflation recordings enables the algorithm to distinguish ischemic from non-ischemic recording.

#### DETAILED DESCRIPTION

Described herein are apparatuses (including devices and systems) and methods for remote diagnostics of cardiac conditions, such as acute myocardial infarction (AMI), atrial fibrillation (AFib), or the like. In particular, described herein are handheld devices with special electrode configurations capable of recording three orthogonal cardiac lead signals in an orientation-specific manner, and transmitting these signals to a processor (e.g., PC or other computing device). The processor may be configured to diagnose/detect AMI and transmit the diagnostic information back to the handheld device. The handheld device may communicate the diagnostic information to the patient via characteristic sounds, voice messages or via a graphical display. The processor may be configured via hardware, software, firmware, or the

like, and may process the signals received to produce a difference signal and extract information reliably related to detection of AMI (and additional information of clinical relevance). Thus, these apparatuses and methods may perform automated detection of cardiac conditions on the basis of a 3-lead system, without the necessity for 12L ECG reconstruction, reducing or eliminating the need for medical personnel to interpret the ECG, unlike prior art systems, which typically rely on medical personnel for such decisions. The automated diagnostic methods described herein, in combination with the improved handheld cardiac devices, address many of the needs and problems present in other systems.

Specifically, described herein are 3-lead cardiac recording devices for user placement on the chest, which include an arrangement of electrodes on both the front and back (and in some variations, one or more sides) so that the devices may be held by both of the user's hand in a predefined orientation, so as to record a 3 lead cardiac signals when held against the user's chest. In order to fulfill above described functions, the handheld device may record three leads without using cables (e.g., may include only surface electrodes held or held against the body). Further, the resulting three leads are non-coplanar, and as close to orthogonal as possible. Finally, at least one electrode may be mounted on the front side of the device (opposite to the chest side), to produce the force needed to hold device against the chest. Unlike prior art devices, there is no requirement for low, non-dipolar content, as the apparatuses and methods described herein do not require reconstruction of 12L ECG from the measured 3 leads.

The handheld devices described herein are configured to be mechanically stable and allow good electrical contact with the chest and to eliminate possibility for switching of finger contacts. The handheld devices described herein may include five electrodes, e.g., four recording electrodes and one ground electrode. Typically, the handheld device may include two chest electrodes which are the recording electrodes, and may be located on the back side of the device. The remaining three non-chest electrodes may be used for collecting cardiac signals from the fingers of the right and left hand and the third one may be used as the ground electrode. At least one of these three non-chest electrodes may be mounted on the front side for pressing with the fingers in order to produce enough pressure to hold the device against the chest. Finally, the requirement of avoiding finger switching may be fulfilled by an asymmetric electrode configuration. For example, one of the three non-chest electrodes may establish contact with one finger of the first hand, and the remaining two electrodes may establish contact with the other hand. One of these two electrodes may be used as common ground electrode and the other may be used for signal measuring. An example of such configuration has two chest recording electrodes, one recording finger electrode on the left side of the device and two finger electrodes on the front side of the device, one recording and one ground electrode. The optimal position of the handheld device on the chest is with center of the device on the left side of the chest approximately above the center of the heart muscle. In this position, the chest electrodes are approximately on the midclavicular line, the vertical line passing through the midpoint of the clavicle bone, same as for the V4 electrode of the conventional ECG, and the lower chest electrode is at about the level of the lower end of the sternum.

In another embodiment, the ground electrode may be excluded from the configuration, which may give acceptable 50-60 Hz electrical noise performance if a ground-free

signal amplifier configuration is used. A four recording electrode configuration (having two chest and two finger electrodes) may also fulfill the condition of high orthogonality discussed above. The simplest way to fulfill this requirement is to record signals in three main body directions: lateral (left arm-right arm), sagittal (back-front) and caudal (head-toes). For example, the signal in the lateral direction may be obtained by measuring the lead between left and right hand. The signal in the caudal direction may be obtained by measuring the lead between the two chest electrodes, with the condition that the distance between the chest electrodes in caudal direction is at least 5 cm, preferably greater than about 10 cm, in order to be greater than the approximate diameter of the heart muscle. In an ideal case, the signal in the sagittal direction would be measured between the back and the chest of the patient, which is not possible with the constraint of using only finger and chest electrodes. To overcome this, we use a simple resistive network to make a central point (CP) that is close to the heart electrical center. For recording a lead in approximately sagittal direction, we record the voltage of the lower chest electrode with respect to a central point (CP), obtained using two hand electrodes and two resistors. The two resistors may be equal, approximately 5 k $\Omega$  each, or unequal, the first one approximately 5 k $\Omega$  between the left hand electrode and the CP, and the second one approximately 10 k $\Omega$  between the right hand electrode and the CP. This asymmetry reflects the left-side position of the heart in the torso, thus shifting the CP at the approximate electrical center of the heart. In this way we obtain a three lead system that are substantially orthogonal.

Other similar lead configurations with the same CP may be chosen using the same set of two chest and two hand electrodes, with the distance between the chest electrodes in caudal direction at least 5 cm, preferably greater than about 10 cm. Such a lead configuration may be substantially orthogonal, for example when both chest electrodes are used to record leads with the reference pole at the CP. Another possibility to define CP is using three electrodes, two hand electrodes and one chest electrode, and 3 resistors connected in a Y (star) configuration.

Other lead configurations without CP may also be used, like the configuration recording the signal of two chest electrodes and right hand electrode with respect to left hand electrode. Such configurations without resistors or CP are more noise resistant to, for example, 50-60 Hz electrical noise, but have less orthogonal lead directions than the described ones using a CP. Generally, any other lead configuration using the same four described electrodes (a total of 20 configurations without a CP) results in leads that are non-coplanar and as such capture diagnostic signal in all three directions, but may lack a high degree of orthogonality. However, these configurations may have different levels of orthogonality, depending on the use of the right hand electrode. The configuration using the right hand electrode as the common reference pole in all 3 leads may have the lowest orthogonality, since the right hand electrode is farthest from the heart among the four electrodes, and thus the angles between the vectors corresponding to the three leads are the smallest. The configurations using right hand electrode in two leads have better orthogonality, while best orthogonality is achieved in the configurations using right hand electrode in only one lead.

The effectiveness of the described solution is not affected if one or more chest electrodes are added on the back side of the device, and one or more corresponding additional leads are recorded and used in diagnostic algorithms. Also,

the effectiveness will not be affected if front electrodes are pressed with palms or any other part of hands instead with the fingers.

In order to prevent turning the device upside down during the recording procedure, so that the upper side is facing toes of the patient, instead of facing his head, which would lead to a useless recording, either upper or front side of the device may be clearly identified and/or formed, (including being marked) to be easily distinguishable by the patient, for example by a LED diode indicating the current phase of recording.

The handheld cardiac device may be configured as a stand-alone device incorporating an ECG recording module including amplifiers and AD convertor, data storage module, communication module operating on GSM, WWAN, or a similar telecommunication standard for communication with the remote processor (e.g., PC computer, pad, smartphone, etc.) and circuitry (e.g., Wi-Fi, Bluetooth, etc.) for communicating the diagnostic information to the user. Alternatively, it can be realized as a modified mobile phone that includes measuring electrodes and the recording module. Furthermore, it can be realized as a device that is attached to the mobile phone as a case or interchangeable back cover. The attached device incorporates measuring electrodes and the recording module and communicates with the mobile phone using a connector or a wireless connection such as Bluetooth or ANT.

If the device is configured as modified mobile phone or as a device attached to a mobile phone, the hand electrodes may be mounted on the display side of a mobile phone. The hand electrodes can be integrated in the edges of the display side of the phone, or as conductive areas incorporated in a transparent layer covering the display of the phone, arranged in the same way as hand electrodes in the preferred embodiment, and marked with a special color when an cardiac signals measuring application is active.

The signal processing and diagnostic software can also be run on the processor (e.g., microprocessor) including a processor integrated in the handheld device, instead of running on a remote processor (e.g., PC computer). In this case, the communication of recorded information to the remote computer may no longer be required, except for data and processing backups. Also, when the diagnostic processing is carried out by a remote processor, a backup version of the software running on the microprocessor may be integrated in the handheld device, and may be used in situations when the user is in a zone without wireless network coverage.

Also described herein are methods and apparatuses for automated detection of AMI (or ischemia, the underlying physiological process). These automated systems may include three cardiac leads that are substantially orthogonal contain the majority of diagnostic information that is present in the conventional 12-lead ECG. Each user may be registered in the diagnostic system by performing the first transmission of his/her non symptomatic cardiac recording with 3 cardiac leads. This first recording may be used as a reference baseline recording for AMI detection in the diagnostic recording (diagnostic recording meaning any further recording of the 3 cardiac leads of the same user). The availability of the reference baseline cardiac recording may allow distinguishing new from old STE (or equivalent parameter), and also other cardiac signal changes suggesting an AMI, providing a tool for automated AMI detection that may have diagnostic accuracy comparable to human ECG interpreters.

The optimal placement of the handheld devices described herein is typically on the chest is with center of the device on the left side of the chest approximately above the center of the heart muscle. In this position, the right edge of the device may be about 3 cm away from the midsternal line, the vertical middle line of the sternum, and the lower edge of the device is at about level of the lower end of the sternum. In an ideal case, the user chooses the optimal position on the chest in the first baseline recording and repeats this position in each future diagnostic recording. In such situation, the cardiac recordings are repeatable, and it is easy to detect cardiac signal changes suggesting an AMI.

In some variations, an adhesive may be used. Thus the apparatus may include an adhesive material or an adhesive patch or dock may be used to connect to reproducibly connect to the apparatus and hold it in a predetermined position on the user. For example, the same recording position of the electrodes during the baseline recording and any further test recording can be achieved using a self-adhesive patch with (or connecting to a device with) the chest electrodes. A self-adhesive patch with the chest electrodes may be attached for the first recordings and remains on the same place on the user chest. Similarly, a patch to which the apparatus may dock to place the electrodes in a predetermined location may be used. The user needs to touch the hand electrodes.

In a realistic case, the user may place the device at a position that is different compared to the baseline position, which may compromise diagnostic accuracy. This misplacement is equivalent to a virtual change of the heart electrical axis in the 3D vector space defined by the 3 cardiac leads. In some variations, this angular change may be calculated for each test recording compared to baseline recording. If the angular change is greater than a threshold, such as 15 degrees, the user may be alerted to choose a position that is closer to the baseline position. If the change is lower than the threshold, it may be compensated for by rotating the signal loops of the test recording in the 3D vector space and get the signal that is substantially equivalent to the baseline signal.

Although switching of the left and right finger or turning the device upside down is not very likely (due to asymmetric electrode configuration and configuration of the apparatus, e.g., by clear marking of the upper or front side of the device), it may still be possible. In this case all three signals may become unusable. Both of these user errors may be easily detected, since in both cases the signal of the lead recorded between the left and the right hand may become inverted. In such case, the user may be alerted to repeat the recording using the correct recording position.

The method for automated detection of AMI (or ischemia) may, in some variations, the following steps: placing the device in a recording position on the user chest; acquisition of a first 3 lead cardiac recording and communicating the signals to the processing unit; storage of the first recording in the data base of the processing unit as baseline recording for further comparison with any subsequent diagnostic recording; acquisition of the 3 lead cardiac diagnostic recording and communicating the signal to the processing unit, and processing of the resulting signals. Processing of the stored baseline signals and signals of the diagnostic recordings by the processing unit may include the following steps: pre-processing to eliminate power line interference, baseline wandering and muscle noise, obtain representative beat using fiducial points and median beat procedure, check for switching of the left and right finger, beat alignment to bring baseline and test recordings' representative beats in the same time frame so as the corresponding points are

synchronized, compensation for chest electrode mispositioning in recording the test signal by compensating the heart electrical axis deviation in the 3 cardiac leads vector space, calculating difference signal, representing the change between baseline and diagnostic 3 cardiac leads signals, detection of cardiac signal changes suggesting ischemia by comparing the parameters of the test recording to the baseline recording or by comparing parameters on the difference signal to a predefined threshold, communicating information by the processing unit to the device, and finally communicating the diagnostic information by the device to the patient.

The STE (ST segment elevation) is the most common ECG change in case of ischemia, usually measured at the J point or up to 80 msec later. Using STE as a parameter, the ischemic changes may be detected by comparing STE in the test recording to the baseline recording. Also, the ischemic changes may be detected by measuring the vector difference of the ST vector in the vector space defined by the 3 special cardiac leads (STVD), taking the baseline recording as a reference. As mentioned above, although these parameters (e.g., ST, J, STVD, STE), are defined with respect to traditional 12-lead ECG signals, they be herein refer to equivalent measures determined for the three cardiac leads (orthogonal signals) described herein. Thus, these equivalent points, regions or phenomena (e.g., STE, ST, J, STVD, etc.) may be identified by comparison between the cardiac signals described herein and traditional ECG signals, including traditional 12-lead ECG signals.

Other parameters of the ECG signal may also be used for comparison with the baseline reference signal, such the "Clew", defined as the radius of the sphere which envelopes the vector signal hodograph between J and J+80 msec points.

Cardiac signals for an individual are highly repeatable as far as their shape is concerned. The changes of the signal shape are generally small for a healthy, or an individual in stable condition. For example, the change of the position of the heart with respect to rib cage can change the heart electrical axis by up to 10°. However, there are conditions when the signal shape may change over time, like Benign Early Repolarization (BER). Such signal changes are highly individual and could be significant. To compensate for such changes, a number of baseline recordings, taken by the user over a period of time, may be used to form a reference that forms a 3D contour in the vector space defined by the 3 special cardiac leads (instead of a single point when single baseline recording is used). In using such a 3D contour reference, the ST vector difference (STVD) may be defined as a distance from the 3D contour instead from the baseline ST vector. If more than one parameter is used for ischemia detection, such a reference contour may be constructed as a hyper-surface in a multidimensional parameter space defined by such parameters. In this case a hyper-distance from the reference hyper-surface will be defined in the said parameter space.

In some conditions, the signal shape changes may also be intermittent (the condition "comes and goes"), like in Brugada syndrome, WPW syndrome, Bundle Branch Blocks (BBB), etc. To compensate for signal changes in such conditions, two groups of baseline recordings (e.g., at least two recordings) may be used to define the reference, one with normal signals and one with the said intermittent condition present. These two groups will form two 3D contours in the vector space, forming a reference for comparison. These two 3D contours may overlap or not. If there is no overlap, the ST vector difference (STVD) will be

defined as a distance from closest point on the two 3D contours. If more than one parameter is used for ischemia detection, such reference contours would be constructed as two hyper-surfaces in a multidimensional parameter space defined by such parameters. In this case a hyper-distance from the reference hyper-surface will be defined in the said parameter space.

Primary use of the methods described herein may be applied to the detection of the most urgent cardiac diagnosis—the AMI. Additionally, the diagnostic methods (e.g., software) in the remote processor (or integrated processor in the handheld device) can detect other cardiac conditions such as chronic Coronary Artery Disease (CAD), Left Ventricular Hypertrophy (LVH), Bundle Branch Blocks (BBB), Brugada syndrome, rhythm disorders such as Atrial Fibrillation (AF) etc.

Although the methods described herein do not require the reconstruction of conventional 12 lead ECG recordings, they may be used to reconstruct them. In many of the above mentioned conditions to be detected, treatment may be urgently needed, although to a lesser extent compared to AMI. Also, many of such conditions are transient, and may be detected using here described technology, but may not be present when the user later comes to the physician's office. In such a case, it would be useful to present the ECG signals for the condition that was discovered at the time of recording, so that physician may use it to confirm the diagnosis. Physicians are familiar with the conventional 12 lead ECG recording. Therefore, 3 special cardiac leads recorded when the condition was discovered may be transformed to produce an approximate reconstruction of conventional 12 lead ECG recording. Such reconstruction may be obtained by multiplication of the 3 special cardiac leads with a 12x3 matrix. This matrix may be obtained as a population matrix, that is a matrix with coefficients that are calculated as average, or median, values of individual matrices obtained by simultaneously recording conventional 12 lead ECG and 3 special cardiac leads in a population of individuals, with each individual matrix obtained using least squares method. The coefficients of such matrices are dependent of the shape of the user's body. Therefore, instead of using a single population matrix, multiple matrices may be used, each for a group of users defined by simple parameters of the body shape and structure, like gender, height, weight, chest circumference, etc., that may be easily obtained by the user. Also, matrix coefficients may be obtained as continuous functions of such body parameters.

FIG. 1A illustrates one variation of a method of operating a system 2 for cardiac signal detection and/or diagnosis. In FIG. 1A, the user may record cardiac signals (e.g., at two or more times), and the apparatus may process the three orthogonal leads to compare the different times (e.g., baseline vs. assay time). The processor of the apparatus may further determine if the resulting differential signal indicates that cardiac problem, and can alert the user. The user (patient) can then get medical assistance as necessary. FIG. 1B shows a view of another variations of a system and method for detecting cardiac dysfunction, including a system 1 for remote diagnostics of AMI including handheld device 2 incorporating built in electrodes for cardiac signal acquisition, mounted directly on the casing 3 of the handheld device and a PC computer 4 connected via a telecommunication link to the device.

The device further incorporates an cardiac signal recording circuitry including amplifiers and AD convertor for amplifying the signals detected by the electrodes, data storage (e.g., memory) for storing the recording signal,

communication circuitry operating on GSM, WWAN, or a similar telecommunication standard for communication with the remote processor 4 and visual and/or audio (e.g., monitor, speaker, etc.) for communicating the diagnostic information to the user.

The device may be communicating with the remote processor 4 via integrated communication circuitry. The remote processor 4 may communicate with the handheld device 2 via integrated communication module. The processor 4 may be equipped with diagnostic software for processing the received cardiac signals, producing diagnostic information and for transmitting the information back to the handheld device for communicating the diagnostic information to the patient via microphone producing characteristic sounds or voice messages or in the form of graphical information via a display integrated in the device. As a consequence, the system may be capable of performing automated detection of a cardiac condition on the basis of a 3-lead system and doesn't require interpretation of the processed diagnostic information by a specialist. Alternatively, instead of a remote processor, the system may include a microprocessor integrated in the casing 3 of the handheld device for processing the recorded cardiac signals and producing diagnostic information.

FIGS. 2A, 2B and 2C show front, back and axonometric views, respectively, of the preferred embodiment of the handheld device. FIG. 2A shows the front view of the device 2 in the recording position as held by the user. The casing 3 of the device may incorporate four recording electrodes A, B, C, D, and one ground electrode G arranged in such arrangement that enables recording of three special ECG lead signals. On the flat back surface 5 of the device in this example are mounted two recording electrodes, A and B, used to make contact with the chest of the patient in the recording position. The two chest electrodes, A and B, are preferably arranged to cover distance greater than at least 5 cm, preferably greater than about 10 cm in caudal direction. The reason for having such spaced arrangement is to achieve the distance greater than approximate diameter of the heart muscle which is needed to approach as much as possible lead orthogonality.

In addition to the two chest electrodes, A and B, the device in this example has two recording electrodes, C and D, mounted on the flat front surface 6 substantially parallel and opposite to the back surface 5. These electrodes, C and D, are used for recording cardiac signals of the hands by pressing with fingers of the left and right hand respectively. The fifth electrode G serves as grounding electrode and is mounted on the front surface 6 for pressing with a left hand finger.

Referring back to FIG. 2A, there is shown a view of the preferred embodiment of the invention in recording position. For operation, the user (e.g., patient) places the device in his left hand so that patient's index and middle finger contact electrodes C and G respectively, positions and presses the device against his chest so that the chest electrodes A and B contact his chest in the manner shown in FIG. 2E for producing tight contact between chest and the device. This may produce enough pressure for holding the device against the chest. Simultaneously, a finger of the right hand (or any other part of the right hand) presses the reference electrode D mounted on the front surface 6 of the casing 3.

Referring back to FIG. 2D there is shown a front view of the device placed against the patient's body in recording position according to the preferred embodiment of the invention. In an optimal recording position the center of the device is placed closely above the center of the heart so that

the chest electrodes A and B are approximately on the midclavicular line (the vertical line passing through the midpoint of the clavicle bone), and the lower chest electrode B is at about the level of the lower end of the sternum.

The example in FIG. 3 shows a simple electrical scheme for obtaining a central point CP by connecting the electrodes of both hands via a simple resistive network with two resistors.

FIG. 4A shows a spatial view of the lead configuration according to one embodiment, illustrating the arrangement of active electrodes A, B, C, D with respect to the body, as well as relative arrangement between the electrodes. FIG. 4B shows a simplified electrical scheme illustrating the same relative arrangement between the electrodes shown in FIG. 4A. For recording a lead in approximately sagittal direction, the voltage of the lower chest electrode B with respect to a central point CP may be obtained using the hand electrodes C, D and two resistors R1, R2. The two resistors R1, R2 can be equal, approximately 5 k $\Omega$ , each, or unequal, approximately 5 k $\Omega$  between the left hand electrode and the CP, and 10 k $\Omega$  between the right hand electrode and the CP. This asymmetry may reflect the left-side position of the heart in the torso, thus putting the CP point at the approximate electrical center of the heart. In this way a substantially orthogonal three lead configuration may be obtained.

FIG. 4C shows a spatial view of an alternative lead configuration with the central point CP using the same set of chest and hand electrodes A, B, C, D, illustrating arrangement of the electrodes with respect to the body, as well as relative arrangement between the electrodes. FIG. 4D shows simplified electrical scheme illustrating the same relative arrangement between the electrodes A, B, C, and D, shown in the FIG. 4C. This alternative lead configuration using a central point CP and measuring two leads between the CP and each of the chest electrodes is also substantially orthogonal, since the chest electrodes A, B are used to record leads with the reference pole at the CP which is obtained using two hand electrodes C, D and two resistors R1, R2.

Other lead configurations without central point CP and resistors may also be used, like the configuration shown in FIG. 4E, recording the signal of two chest electrodes and right hand electrode with respect to left hand electrode. Other two similar configurations are shown in FIGS. 4F and 4G. Such configurations without resistors are subject to less external interference, such as 50-60 Hz electrical noise, but have less orthogonal lead directions than the previously described ones using a CP. Generally, any other lead configuration using the same four described electrodes may result in non-coplanarity and, as such, captures the diagnostic signal in all three directions, but lacks high orthogonality. There are a total of 20 possible configurations without a CP, including ones shown in FIGS. 4E, 4F and 4G. However, these configurations have different levels of orthogonality, depending on the use of the right hand electrode. The configuration using the right hand electrode as the common reference pole in all 3 leads have the lowest orthogonality, since the right hand electrode is farthest from the heart among the four electrodes, and thus the angles between the vectors corresponding to the three leads are the smallest. The configurations using right hand electrode in two leads, such as the configuration shown in FIG. 4F, have better orthogonality, while best orthogonality is achieved in the configurations using right hand electrode in only one lead, such as the configurations shown in FIGS. 4E and 4G.

FIGS. 5A, 5B and 5C show front view, back view and an axonometric view, respectively, of an alternative embodiment of the hand held device, whereby FIG. 5A shows the

front view of the device in the recording position as held by the user. In the alternative embodiment, the electrode D1 for recording ECG signal of the right arm by pressing with finger of the right hand is mounted on the flank 71 of the casing 31, instead on the front surface 61 as in the embodiment described above. Active recording electrodes A1 and B1 for recording ECG signal of the patient's chest are mounted on the back surface 51 of the device in the same manner as in the embodiment above. An active recording electrode C1 for recording ECG signal of the left hand by pressing with finger of the left hand and ground electrode G1 for pressing with another finger of the left hand are mounted on the front surface 61 also in the same manner as above.

The finger switching may be prevented by having an asymmetric electrode configuration, so that the right hand electrode cannot be wrongly pressed by the left hand, and vice versa. However in each of the embodiments (preferred and alternative), the upper (facing head) and lower part (facing toes) of the device may be easily distinguished, since turning the device upside down would lead to wrong recording. This may be done by integrating LED diodes in either upper or front side of the device, indicating the current recording phase, in the front surface of the device casing.

The handheld cardiac device may be realized as a stand-alone device incorporating an ECG recording circuitry including amplifiers and AD converter, data storage circuitry (memory), communication circuitry operating on GSM, WWAN, or a similar telecommunication standard for communication with the remote PC computer and an output for communicating the diagnostic information to the user (e.g., screen, speaker, etc.). In so embodiments, the apparatus may be configured to operate with a modified mobile phone that includes measuring electrodes and the cardiac signal recording capability. Furthermore, the apparatus can be realized as a system that is attached to a mobile phone (smartphone) as a case or interchangeable back cover. The attached device may incorporate measuring electrodes and the cardiac signal recording module (including electrodes, balancing circuit, etc.) and communicates with the mobile phone using a connector or a wireless connection such as Bluetooth or ANT.

FIGS. 6A, 6B and 6C show a front view, back view and axonometric view, respectively, of another alternative embodiment of the hand held device. On the back side 52 of the device there are electrodes A2, B2 are mounted for touching the chest of the patient conducting the recording in the same manner as in the preferred embodiment. On the front side 62 of the device there are three electrodes, an active electrode C2, a reference electrode D2 and a ground electrode G2. All three electrodes C2, D2 and G2 have elongated, beam or band like shape and are integrated on the front side 62 of the device, preferably along the two longer, parallel edges of the housing 32 so as to be partially accessible from the sides. In the recording position, the electrodes C2, D2 and G2 are touched by fingers of the left and right hand, in the manner equivalent to the one shown for electrodes C, D and G shown in FIG. 2A, respectively. This electrode arrangement is suitable if the device is realized as a modified mobile phone that includes measuring electrodes and the cardiac signal recording module, or if it is realized as a device that is attached to the mobile phone as a case or interchangeable back cover. In such embodiment, the elongated electrodes may be a part of the frame surrounding the display of the mobile phone or tablet.

Beside, this alternative electrode arrangement, featuring two electrodes on one side and on electrode on the opposite

side, fulfills the requirement of asymmetry as well, needed for avoiding finger switching.

In another alternative embodiment, the device is a modified mobile phone that includes recording electrodes and the cardiac signal recording module, with a touch screen. The three hand electrodes for pressing with hands or fingers are realized as transparent conductive areas incorporated in a transparent layer covering the display of the phone, arranged in the same way as hand electrodes in the preferred embodiment. The smart phone application will mark the conductive areas on the screen with a special color when the cardiac signal recording application is active.

In another alternative embodiment, the device contains self-adhesive patch with the chest electrodes. The self-adhesive patch is attached on the user chest enabling the same chest electrode positions for the baseline and all subsequent diagnostic recordings as described above. Alternatively or additionally, the apparatus (e.g., system) may include a patch having a docking region for connecting with any of the electrode-including devices described herein, that may be used to connect (or provide fiducial reference for) the device to the same location on a user's chest. For example, a docking adhesive patch may include a mating component or region that connects to the device to hold the chest electrodes on the device in a reproducible location on the user's chest. In some variations, the docking adhesive comprises a Band-Aid type material that is worn by the user over an extended period of time (e.g., hours, days, weeks), and may be replaced with another adhesive to maintain the same reference location.

FIG. 7 shows another embodiment of the device realized as an extension **83** to a mobile phone, such as a case or interchangeable back cover, having a form of a so called flip case or wallet for mobile phone, incorporating chest electrodes **A3** and **B3** on the back side of the device, and the left and right hand finger electrodes **C3**, **D3** and **G3** incorporated in the flip-type phone display cover **93** of mobile phone casing.

FIG. 8 shows a block diagram of the method for automated detection of AMI according to the preferred embodiment of the invention. A method for automated detection of AMI (or ischemia) may include all or some of the steps described below. First, placing the device in a recording position on the user chest.

An optimal position of the handheld device on the chest is with center of the device on the left side of the chest approximately above the center of the heart muscle. In this position, the chest electrodes are approximately on the midclavicular line, the vertical line passing through the midpoint of the clavicle bone, same as for the V4 electrode of the conventional ECG, and the lower chest electrode is at about the level of the lower end of the sternum. The user presses one active electrode and one ground electrodes with the fingers of the left hand and one active electrode with the finger of the right hand on the front side of the device.

The method may also include acquisition of a first 3 lead cardiac recording and communicating the signals to the processing unit. The user of the automated AMI diagnostic system may perform the recording of the 3-lead cardiac signal by holding the handheld device against the chest for a short period of time (e.g., at least 30 seconds, at least 20 seconds, at least 10 seconds, at least 5 seconds, etc.). The recording is stored in the memory of the device and then transmitted to the remote PC computer via commercial communication network.

The method may also include storage of the first recording in the data base of the processing unit as a baseline. After

performing the first transmission of his/her cardiac signal, the cardiac signal recording is stored in a remote processor, and the user may be registered in the diagnostic system. Before this first transmission, the user or his MD/nurse may enter (via a dedicated web site) his medical data such as age, gender, risk factors for cardiovascular disease, etc., and indicate if he/she is currently having chest pain or any other symptom suggesting ischemia. If the answer is negative, this first cardiac recording is kept in the diagnostic system as a baseline recording that will serve as a reference for comparison in any further transmission when symptoms suggesting ischemia may occur.

The method may further include acquisition of the 3 lead cardiac diagnostic recording and communicating the signal to the processing unit. Any subsequent recording after the baseline recording has been accepted and stored in the data base is considered to be diagnostic recording. The user of the automated AMI diagnostic system performs the diagnostic recording of the 3-lead cardiac signal by holding the handheld device against the chest for at least 10 seconds. The diagnostic recording is stored in the memory of the device and then transmitted to the remote PC computer via commercial communication network.

In general, the methods described herein may include processing of the stored signals of baseline and diagnostic recordings by the processing unit. Processing may include pre-processing. For example the apparatus/method may be configured to let  $V_a$ ,  $V_b$ ,  $V_c$  be the 3 special leads recorded using the handheld device. Before performing any analysis, cardiac signal must be "cleaned" from the disturbing factors like power line interference, baseline wandering and muscle noise. While the former two may be removed using standard adaptive filtering and cubic spline techniques, respectively, the latter is suppressed using time-averaging median beat procedure.

To create a median beat, the entire cardiac signal may be delineated, resulting in set of fiducial points  $S = \{P_1, P_2, \dots, P_n\}$ , where  $P_i = \{Q_i, R_i, J_i, T_i, T_{i,end}\}$  (or points equivalent to these locations) are fiducial points of  $i$ -th beat. Based on  $S$ , the signal is then divided into  $n$  individual beats of the same length. Finally, individual beats are synchronized using cross-correlation (CC) and for each sample median value across all  $n$  beats is calculated. Thus, the entire cardiac signal is represented by the single most-representative median beat. A set of fiducial points  $P = \{Q, R, J, T, T_{end}\}$  associated to the median beat are simply calculated as median values of the fiducial point of the individual beats.

Techniques for obtaining representative beat other than median beat may also be used. The delineation of the cardiac signal resulting in fiducial points for each beat may be done using different techniques like wavelet transform, support vector machine, etc.

The same pre-processing procedure is used for both baseline and diagnostic recording.

If the lead recorded between the left and the right hand, or other lead capturing the signal in the lateral direction, is inverted, the user is alerted to repeat the recording using the correct recording position.

The processing may also include beat alignment. For example, the apparatus or method may be configured to let  $B$  and  $D$  denote to the median beats extracted from the baseline and diagnostic ECGs, respectively, and  $P_B$  and  $P_D$  are their associated fiducial points. The goal of beat alignment is to bring  $B$  and  $D$  in the same time frame so as the corresponding points are accurately synchronized. This involves finding of such transformed  $B$ , referred to as  $B^*$ , so that it is optimally synchronized to the  $D$ . The applied

transformation is piece-wise uniform re-sampling of B, so that corresponding segments in B\* and D, defined by PB and PD, respectively, have the same number of samples. Optimal alignment is obtained by searching for such fiducial points PB\* that optimize cost function or similarity measure (SM) which quantifies the alignment:

$$P_B^* = \text{argopt}_{P_B} \text{SM} \quad (1)$$

B\* is then obtained by transforming B using the  $P_B^*$ .

In the present embodiment, we used CC which is commonly used SM for shape-based alignment problems. However, use of solely CC may lead to wrong alignment as shape in B and D may be significantly different. Therefore, we introduce weighting functions  $f_{wi}$ , which penalizes large deviations from the  $P_B^*$ , as the fiducial points  $P_B$  are assumed to be accurately known:

$$f_{wi} = e^{-\left(\frac{\Delta P_{Bi}}{ci}\right)^2} \quad (2)$$

where  $i=Q, R, J, T, T_{end}$ .  $\Delta P_{Bi}$  is deviation from the  $i$ -th fiducial point and  $ci$  is scaling factor which depends on the fiducial points. Namely, as the R point is the most stable reference in ECG signal, its deviation is penalized the most. On the other hand, as J and  $T_{end}$  points are the least stable, thus, larger deviations are allowed. The overall SM is then calculated as product of CC and sum of weighting functions  $f_{wi}$ :

$$\text{SM} = \text{CC}(B(P_B), D) \sum_{i=1}^5 f_{wi} (|P_B - P_{Bi}|) \quad (3)$$

Finally, according to the Eq. (1) the  $B^*$  is obtained by finding optimum of SM given in Eq. (3).

The processing may also include compensation for chest electrode mispositioning. During regular use of the handheld device, chest electrodes may not be placed on the same spot every time, thus leading to changes in shape of cardiac signal even in absence of any pathology. This change can be modeled as "virtual" heart electrical axis deviation in the Va, Vb, Vc leads vector space if lead positions are assumed to be constant, with the heart electrical axis represented by the R vector—the heart vector at the moment of maximal magnitude in the QRS complex (or equivalent region in the three-lead cardiac signals described herein). However, this is undesired property as the difference signal  $\Delta D$  will be significant, even though there are no pathologically induced changes. To overcome this problem, we transform D, resulting in  $D^*=TD$ , so that its heart electrical axis overlaps with the axis of  $B^*$ . The transform T is calculated using least squares method and Q-J segment (QRS complex) of D and  $B^*$  as input.

In general, processing may also include calculating difference signal, representing the change between baseline and diagnostic3 cardiac leads signals. The difference signal  $\Delta D^*$  is calculated as:

$$\Delta D^* = D^* - B^* \quad (4)$$

Ultimately, such difference signal  $\Delta D^*$  will reflect solely pathologically induced changes and it will be independent on heart axis deviation.

Since the quality of the device misplacement compensation decreases with increase of the angle heart axis deviation, if the angular change is greater than a threshold, such as 15 deg, the user is prompted to choose a position that is closer to the baseline position.

The processing methods and apparatus described herein may also include detection of ischemic changes. The STE is

the most common ECG change in case of ischemia, measured usually at the J point or up to 80 msec later. In the present solution, the ischemic changes are detected by comparing the test recording to the baseline recording. In the preferred embodiment, the parameter or "marker" for ischemia detection is STVM (or equivalent region in the cardiac signals described herein), the vector magnitude of the corrected difference signal  $\Delta D$  at 80 msec after the J point (J+80 msec), compared to a predefined threshold, such as 0.1 mV.

In other embodiments, vector magnitude in other time points may be used as marker for ischemia, such as J point, J+60 msec, T max, etc. Other markers may be used that describe the shape of the ST segment (ECG signal segment between J and J+80 msec points, or similar). Such a marker is the "Clew", defined as the radius of the sphere which envelopes the vector signal hodograph between J and J+80 msec points. Also, other composite markers may be used, such as a logistic regression using a linear combination of STVM and Clew markers.

To compensate for signal shape change over time, a number of baseline recordings, taken by the user over a period of time, may be used to form a reference that forms a 3D contour in the vector space defined by the 3 special cardiac leads (instead of a single point when single baseline recording is used). In using such a 3D contour reference, the ST vector difference (STVD) will be defined as a distance from the 3D contour instead from the baseline ST vector. If more than one parameter is used for ischemia detection, such a reference contour would be constructed as a hyper-surface in a multidimensional parameter space defined by such parameters. In this case a hyper-distance from the reference hyper-surface will be defined in the said parameter space.

In users having cardiac condition with intermittent signal shape changes, compensation for such changes may be done by forming two groups of baseline recordings (at least two recordings) to define the reference, one with normal signals and one with the said condition. These two groups will form two 3D contours in the vector space, forming a reference for comparison, and the ST vector difference (STVD) will be defined as a distance from closest point on the two 3D contours. If more than one parameter is used for ischemia detection, such reference contours would be constructed as two hyper-surfaces in a multidimensional parameter space defined by such parameters. In this case a hyper-distance from the reference hyper-surface will be defined in the said parameter space.

Any of these methods and apparatuses may be configured for communicating information by the processing unit to the device. The created diagnostic information may be transmitted from the remote processor (e.g., a PC computer, server, etc.) to the device memory via commercial communication network. The method and apparatuses may also be configured for communicating the diagnostic information by the device to the patient. The received diagnostic information may be presented to the user in a form of characteristic sound, voice, graphics or text.

Additionally, an approximate conventional 12 lead ECG signal may be sent to the user's physician for evaluation. This signal may be produced as an approximate reconstruction of conventional 12 leads by transforming the 3 special cardiac leads signals recorded by the user. This reconstruction may be obtained by multiplication of the 3 special cardiac leads with a  $12 \times 3$  matrix. In one embodiment, this matrix may be obtained computationally by using a general solution of potentials distribution on the surface of the human body, similar to those previously described for defining a conventional vector cardiogram. In another embodi-

ment, this matrix may be obtained as a population matrix, that is a matrix with coefficients that are calculated as an average, or median, values of individual matrices obtained by simultaneously recording conventional 12 lead ECG and 3 special cardiac leads in a population of individuals, with each individual matrix obtained using least squares method. In yet another embodiment, multiple matrices may be used in corresponding user groups defined by simple parameters of the body shape and structure, like gender, height, weight, chest circumference, etc., that may be easily obtained by the user. Also, matrix coefficients may be obtained as continuous functions of such body parameters.

EXAMPLES

A clinical study was done to evaluate the diagnostic accuracy of the methods described above for detecting myocardial ischemia provoked by balloon inflation in coronary arteries during a PCI (Percutaneous Coronary Intervention) procedure.

In this example, data was acquired continuously. Continuous data from standard 12 lead ECG with additional three special leads were obtained from each patient during the entire period of balloon occlusion, and for a short period before and after. Target duration for balloon occlusion was at least 90 sec if the patient is stable. In each patient, one baseline recording was taken prior to the beginning of the PCI procedure, and one pre-inflation during the procedure, prior to first balloon insertion. In each lesion/intervention site, one inflation recording was taken just before the balloon deflation. The analyzed data set contains ECG recordings of 66 patients and 120 balloon occlusions (up to three arteries inflated per patient).

Data was analyzed by the methods described above (using the embodiment with a linear combination of STVM and "Clew" markers), and results were compared to the interpretation of the same data set by three experienced cardiologist (one interventional cardiologist, two cardiac electrophysiologists), blinded to any clinical data. All inflation recordings were assumed to be ischemia-positive and all pre-inflation recordings to be ischemia-negative. The study data set was divided into two sets of approximately same sizes, learning and test sets (using a random number generator). The markers for ischemia detection were chosen and marker thresholds tuned on the learning set before the algorithm was applied to the test set.

Table 1, below illustrates the results of this study, comparing automatically scored readings with readings scored by human (e.g., cardiologist), showing a greater success rate using the automatic methods described herein compared to those of trained human experts (human reader's average).

TABLE 1

Sensitivity, specificity and accuracy of the automated method compared to human expert reading.			
	SEN [%]	SPE [%]	ACC [%]
Automated method	89.06	91.18	89.80
Human readers	76.11	64.14	71.86
Difference	12.95	27.04	17.93

The results given in Table 1 show the superiority of using the availability of the reference baseline cardiac recording for distinguishing new from old ST deviation.

Another clinical study was done to evaluate the diagnostic accuracy of the algorithm based on 3 orthogonal cardiac

leads in detecting Atrial Fibrillation. The data set included 453 recordings from 25 patients after Pulmonary Vein Isolation (227 recordings with sinus rhythm and 226 with Atrial Fibrillation). The "Clew" marker was applied to the P wave, combined with commonly used RR interval marker. Table 1, below illustrates the results of this study.

TABLE 2

Performance of the automated method in detecting Atrial Fibrillation			
	SEN [%]	SPE [%]	ACC [%]
Automated method	99.12	92.04	95.58

When a feature or element is herein referred to as being "on" another feature or element, it can be directly on the other feature or element or intervening features and/or elements may also be present. In contrast, when a feature or element is referred to as being "directly on" another feature or element, there are no intervening features or elements present. It will also be understood that, when a feature or element is referred to as being "connected", "attached" or "coupled" to another feature or element, it can be directly connected, attached or coupled to the other feature or element or intervening features or elements may be present. In contrast, when a feature or element is referred to as being "directly connected", "directly attached" or "directly coupled" to another feature or element, there are no intervening features or elements present. Although described or shown with respect to one embodiment, the features and elements so described or shown can apply to other embodiments. It will also be appreciated by those of skill in the art that references to a structure or feature that is disposed "adjacent" another feature may have portions that overlap or underlie the adjacent feature.

Terminology used herein is for the purpose of describing particular embodiments only and is not intended to be limiting of the invention. For example, as used herein, the singular forms "a", "an" and "the" are intended to include the plural forms as well, unless the context clearly indicates otherwise. It will be further understood that the terms "comprises" and/or "comprising," when used in this specification, specify the presence of stated features, steps, operations, elements, and/or components, but do not preclude the presence or addition of one or more other features, steps, operations, elements, components, and/or groups thereof. As used herein, the term "and/or" includes any and all combinations of one or more of the associated listed items and may be abbreviated as "/".

Spatially relative terms, such as "under", "below", "lower", "over", "upper" and the like, may be used herein for ease of description to describe one element or feature's relationship to another element(s) or feature(s) as illustrated in the figures. It will be understood that the spatially relative terms are intended to encompass different orientations of the device in use or operation in addition to the orientation depicted in the figures. For example, if a device in the figures is inverted, elements described as "under" or "beneath" other elements or features would then be oriented "over" the other elements or features. Thus, the exemplary term "under" can encompass both an orientation of over and under. The device may be otherwise oriented (rotated 90 degrees or at other orientations) and the spatially relative descriptors used herein interpreted accordingly. Similarly, the terms "upwardly", "downwardly", "vertical", "horizon-

tal” and the like are used herein for the purpose of explanation only unless specifically indicated otherwise.

Although the terms “first” and “second” may be used herein to describe various features/elements (including steps), these features/elements should not be limited by these terms, unless the context indicates otherwise. These terms may be used to distinguish one feature/element from another feature/element. Thus, a first feature/element discussed below could be termed a second feature/element, and similarly, a second feature/element discussed below could be termed a first feature/element without departing from the teachings of the present invention.

As used herein in the specification and claims, including as used in the examples and unless otherwise expressly specified, all numbers may be read as if prefaced by the word “about” or “approximately,” even if the term does not expressly appear. The phrase “about” or “approximately” may be used when describing magnitude and/or position to indicate that the value and/or position described is within a reasonable expected range of values and/or positions. For example, a numeric value may have a value that is  $\pm 0.1\%$  of the stated value (or range of values),  $\pm 1\%$  of the stated value (or range of values),  $\pm 2\%$  of the stated value (or range of values),  $\pm 5\%$  of the stated value (or range of values),  $\pm 10\%$  of the stated value (or range of values), etc. Any numerical range recited herein is intended to include all sub-ranges subsumed therein.

Although various illustrative embodiments are described above, any of a number of changes may be made to various embodiments without departing from the scope of the invention as described by the claims. For example, the order in which various described method steps are performed may often be changed in alternative embodiments, and in other alternative embodiments one or more method steps may be skipped altogether. Optional features of various device and system embodiments may be included in some embodiments and not in others. Therefore, the foregoing description is provided primarily for exemplary purposes and should not be interpreted to limit the scope of the invention as it is set forth in the claims.

The examples and illustrations included herein show, by way of illustration and not of limitation, specific embodiments in which the subject matter may be practiced. As mentioned, other embodiments may be utilized and derived there from, such that structural and logical substitutions and changes may be made without departing from the scope of this disclosure. Such embodiments of the inventive subject matter may be referred to herein individually or collectively by the term “invention” merely for convenience and without intending to voluntarily limit the scope of this application to any single invention or inventive concept, if more than one is, in fact, disclosed. Thus, although specific embodiments have been illustrated and described herein, any arrangement calculated to achieve the same purpose may be substituted for the specific embodiments shown. This disclosure is intended to cover any and all adaptations or variations of various embodiments. Combinations of the above embodiments, and other embodiments not specifically described herein, will be apparent to those of skill in the art upon reviewing the above description.

What is claimed is:

1. A method for automated cardiac diagnostics, the method comprising:

acquiring a first set of at least three orthogonal leads from a patient’s chest and hands at a first time;

acquiring a second set of at least three orthogonal leads from the patient’s chest and hands a second time;

determining if the second set of at least three orthogonal leads is rotated relative to the first set of at least three orthogonal leads in a three-dimensional (3D) vector space and compensating for any rotation;

performing a beat alignment in a processor on the first and second sets of at least three orthogonal leads to synchronize representative beats from the first and second sets of at least three orthogonal leads;

calculating a difference signal representing the change between the first and second at least three orthogonal leads in the 3D vector space;

detecting cardiac changes suggestive of a cardiac condition by comparing parameters of the first and second at least three orthogonal leads or by comparing parameters of the difference signal to a predefined threshold; and

communicating cardiac changes to the patient.

2. A method for automated cardiac diagnostics, the method comprising:

positioning a device configured to detect at least three orthogonal leads from a patient’s chest and hands against the subject’s chest in a first recording position; acquiring a first set of at least three orthogonal leads from the device at a first time;

communicating the first set of at least three orthogonal leads to a processor;

positioning the device against the subject’s chest in a second recording position;

acquiring a second set of at least three orthogonal leads from the patient using the device at a second time;

communicating the second set of at least three orthogonal leads to the processor;

determining if the second set of at least three orthogonal leads is rotated relative to the first set of at least three orthogonal leads in a vector space and compensating for any rotation;

performing a beat alignment in the processor to synchronize representative beats from the first and second sets of at least three orthogonal leads;

calculating a difference signal representing the change between the first and second sets of at least three orthogonal leads in the vector space;

detecting cardiac changes suggestive of a cardiac condition by comparing one or more parameters of the difference signal to a predefined threshold;

communicating cardiac changes from the device to the patient.

3. The method of claim 2, wherein positioning the device comprises placing a housing of the device having four integrated electrodes against the patient’s chest.

4. The method of claim 2, wherein communicating the first and second sets of at least three orthogonal leads to the processor comprises communicating the first and second sets of at least three orthogonal leads to a local processor within the housing.

5. The method of claim 2, wherein detecting cardiac changes comprises detecting one or more of: acute ischemia, atrial fibrillation, atrial flutter, premature ventricular contractions (PVCs), and premature atrial contractions (PACs).

6. The method of claim 2, wherein the first and second recording positions are the same position.

7. The method of claim 2, wherein the first and second recording positions are different.

8. The method of claim 2, wherein communicating the first and second sets of at least three orthogonal leads to the

processor comprises wirelessly transmitting the first and second sets of at least three orthogonal leads to a remote processor.

9. The method of claim 2, further comprising pre-processing the first and second sets of at least three orthogonal leads in the processor to achieve one or more of:

eliminate power line interference, baseline wandering and/or muscle noise; obtain a representative beat using fiducial points and median beat procedure; and check for switching of the left and right finger.

10. The method of claim 2, wherein detecting cardiac changes suggestive of the cardiac condition comprises determining the Clew of a P wave and processing said Clew in order to detect atrial fibrillation.

11. The method of claim 2, further comprising transmitting any ECG changes suggestive of a cardiac condition from the processor to the device.

12. The method of claim 2, wherein communicating any ECG changes suggestive of a cardiac condition from the device to the patient comprises presenting a visual and/or audible alert to the patient.

13. A method for automated ECG diagnostics, the method comprising:

placing a device comprising a housing having four integrated electrodes arranged to measure three orthogonal leads from a patient's chest and hands against the subject's chest in a first recording position;

acquiring a first 3 lead ECG recording from the device at a first time;

communicating the first 3 lead ECG recording to a processor;

storing the first 3 lead ECG recording as baseline recording;

placing the device against the subject's chest in a second recording position;

acquiring a second 3 lead ECG recording from the device at a second time;

communicating the second 3 lead ECG recording to the processor;

pre-processing the first and second 3 lead ECG recordings in the processor to eliminate power line interference, baseline wandering and muscle noise, obtain a representative beat using fiducial points and median beat procedure, and to check for switching of the left and right finger;

performing beat alignment in the processor to bring representative beats from the first and second 3 lead ECG recordings in a same time frame so that corresponding points are synchronized;

compensating for chest electrode miss-positioning between the first and second recording positions in the processor by compensating a heart electrical axis deviation in a 3 ECG leads vector space;

calculating a difference signal representing the change between the first and second 3 ECG leads recordings;

detecting ECG changes suggesting ischemia by comparing parameters of the first and second 3 lead ECG recording or by comparing parameters of the difference signal to a predefined threshold;

communicating any ECG changes suggesting ischemia from the device to the patient.

\* \* \* \* \*

专利名称(译)	用于自动诊断的移动式三导心脏监测设备和方法		
公开(公告)号	<a href="#">US10433744</a>	公开(公告)日	2019-10-08
申请号	US15/096159	申请日	2016-04-11
[标]申请(专利权)人(译)	BOJOVIC博斯科 HADZIEVSKI LJUPCO VUKCEVIC VLADAN MITROVIC UROS 米莱迪克Marjan		
申请(专利权)人(译)	BOJOVIC, 博斯科 HADZIEVSKI, LJUPCO VUKCEVIC, VLADAN 米特罗维奇, UROS MILETIC, MARJAN		
当前申请(专利权)人(译)	HEARTBEAM, INC.		
[标]发明人	BOJOVIC BOSKO HADZIEVSKI LJUPCO VUKCEVIC VLADAN MITROVIC UROS MILETIC MARJAN		
发明人	BOJOVIC, BOSKO HADZIEVSKI, LJUPCO VUKCEVIC, VLADAN MITROVIC, UROS MILETIC, MARJAN		
IPC分类号	A61B5/04 A61B5/00 A61B5/0404 A61B5/046 G16H40/67 G16H50/20 G16H40/63 A61B5/0408		
CPC分类号	A61B5/04011 A61B5/6825 G16H50/20 A61B5/04012 A61B5/684 A61B5/6898 A61B5/04085 G16H40/67 A61B5/747 A61B5/046 A61B5/0404 G16H40/63 A61B5/0006 A61B5/6823 A61B2560/0468 A61B2562/0209 G06F19/00 G06F19/3418		
优先权	62/145431 2015-04-09 US		
其他公开文献	US20160296132A1		
外部链接	<a href="#">Espacenet</a>		

#### 摘要(译)

用于远程和检测和/或诊断急性心肌梗塞 (AMI) 的方法和装置, 包括设备和系统。特别地, 本文描述的是具有电极配置的手持式设备, 该电极配置能够以特定于取向的方式记录三个正交的ECG导联信号, 并将这些信号发送到处理器。该处理器可以是远程的或本地的, 并且可以基于对所记录的3个心脏信号相对于先前存储的基线记录的偏差的分析, 自动或半自动地检测AMI, 心房纤颤或其他心脏疾病。

