



US010092186B2

(12) **United States Patent**
Hatlestad et al.

(10) **Patent No.:** **US 10,092,186 B2**
(45) **Date of Patent:** ***Oct. 9, 2018**

(54) **ADVANCED PATIENT MANAGEMENT WITH ENVIRONMENTAL DATA**

(71) Applicant: **Cardiac Pacemakers, Inc.**, St. Paul, MN (US)

(72) Inventors: **John D. Hatlestad**, Maplewood, MN (US); **Jeffrey E. Stahmann**, Ramsey, MN (US); **Qingsheng Zhu**, Wexford, PA (US)

(73) Assignee: **Cardiac Pacemakers, Inc.**, St. Paul, MN (US)

(*) Notice: Subject to any disclaimer, the term of this patent is extended or adjusted under 35 U.S.C. 154(b) by 0 days.

This patent is subject to a terminal disclaimer.

(21) Appl. No.: **15/332,609**

(22) Filed: **Oct. 24, 2016**

(65) **Prior Publication Data**

US 2017/0035297 A1 Feb. 9, 2017

Related U.S. Application Data

(63) Continuation of application No. 13/185,121, filed on Jul. 18, 2011, now Pat. No. 9,480,848, which is a (Continued)

(51) **Int. Cl.**

A61B 5/00 (2006.01)

G06F 19/00 (2018.01)

(Continued)

(52) **U.S. Cl.**

CPC **A61B 5/0031** (2013.01); **A61B 5/0022** (2013.01); **A61B 5/0205** (2013.01);

(Continued)

(58) **Field of Classification Search**

CPC A61B 5/02; A61B 5/02028; A61B 5/0205; A61B 5/4842; A61B 5/7275; A61N 1/3627

See application file for complete search history.

(56) **References Cited**

U.S. PATENT DOCUMENTS

4,310,003 A 1/1982 Schlager
4,389,609 A 6/1983 Kawamura

(Continued)

FOREIGN PATENT DOCUMENTS

EP 0297675 A1 1/1989
EP 0362611 A1 4/1990

(Continued)

OTHER PUBLICATIONS

US 6,527,714, 03/2003, Bardy (withdrawn)

(Continued)

Primary Examiner — Scott Getzow

(74) *Attorney, Agent, or Firm* — Schwegman Lundberg & Woessner, P.A.

(57) **ABSTRACT**

Systems, devices and methods for using environmental data to manage health care are disclosed. One aspect is an advanced patient management system. In various embodiments, the system includes at least one implantable medical device (IMD) to acquire at least one IMD parameter indicative of patient wellness, means to acquire at least one environmental parameter from at least one external source, and means to correlate the at least one parameter indicative of patient wellness and the at least one environmental parameter to assist with patient health care decisions. Other aspects and embodiments are provided herein.

20 Claims, 21 Drawing Sheets

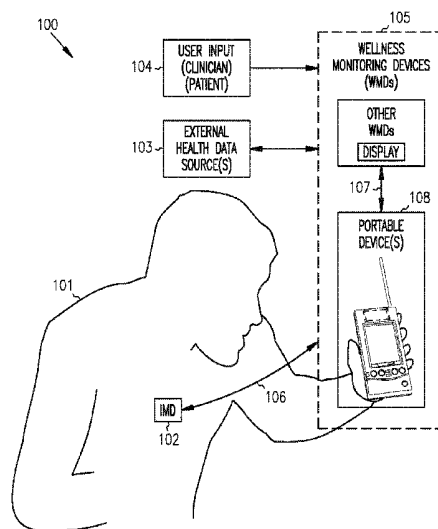

Related U.S. Application Data

continuation of application No. 12/350,875, filed on Jan. 8, 2009, now Pat. No. 7,983,745, which is a continuation of application No. 10/323,590, filed on Dec. 18, 2002.

(51) **Int. Cl.**

- A61B 5/0205* (2006.01)
- A61B 5/11* (2006.01)
- A61B 7/04* (2006.01)
- G16H 40/63* (2018.01)
- G16H 50/30* (2018.01)
- A61N 1/372* (2006.01)
- A61B 5/053* (2006.01)
- A61B 5/08* (2006.01)
- A61B 5/091* (2006.01)

(52) **U.S. Cl.**

- CPC *A61B 5/1118* (2013.01); *A61B 7/04* (2013.01); *A61N 1/37282* (2013.01); *G06F 19/3418* (2013.01); *G16H 40/63* (2018.01); *G16H 50/30* (2018.01); *A61B 5/0537* (2013.01); *A61B 5/0816* (2013.01); *A61B 5/091* (2013.01); *A61B 2560/0247* (2013.01); *A61B 2560/0252* (2013.01); *A61B 2560/0257* (2013.01); *A61N 1/37252* (2013.01)

(56)

References Cited

U.S. PATENT DOCUMENTS

4,519,395 A	5/1985	Hrushesky	5,700,283 A	12/1997	Salo
4,712,179 A	12/1987	Heimer	5,716,382 A	2/1998	Snell
4,777,960 A	10/1988	Berger et al.	5,720,771 A	2/1998	Snell
4,796,634 A	1/1989	Huntsman et al.	5,722,999 A	3/1998	Snell
4,809,697 A	3/1989	Causey, III et al.	5,724,985 A	3/1998	Snell et al.
4,825,869 A	5/1989	Sasmor et al.	5,731,296 A	3/1998	Sollevi
4,838,275 A	6/1989	Lee	5,732,709 A	3/1998	Tacklind et al.
4,886,064 A	12/1989	Strandberg	5,752,976 A	5/1998	Duffin et al.
4,928,688 A	5/1990	Mower	5,759,199 A	6/1998	Snell et al.
4,967,749 A	11/1990	Cohen	5,790,534 A	8/1998	Kokko et al.
4,987,897 A	1/1991	Funke	5,792,064 A	8/1998	Panescu et al.
5,031,629 A	7/1991	DeMarzo	5,800,473 A	9/1998	Faisandier
5,047,930 A	9/1991	Martens et al.	5,822,544 A	10/1998	Chaco et al.
5,097,831 A	3/1992	Lekholm	5,833,623 A	11/1998	Mann et al.
5,113,869 A	5/1992	Nappholz et al.	5,860,918 A	1/1999	Schradi et al.
5,174,289 A	12/1992	Cohen	5,873,894 A	2/1999	Vandegriff et al.
5,226,413 A	7/1993	Bennett et al.	5,891,178 A	4/1999	Mann et al.
5,251,626 A	10/1993	Nickolls et al.	5,904,708 A	5/1999	Goedeke
5,262,944 A	11/1993	Weisner et al.	5,911,132 A	6/1999	Sloane
5,282,838 A	2/1994	Hauser et al.	5,935,078 A	8/1999	Feierbach
5,292,341 A	3/1994	Snell	5,935,081 A	8/1999	Kadhiresan
5,306,293 A	4/1994	Zacouto	5,942,986 A	8/1999	Shabot et al.
5,309,919 A	5/1994	Snell et al.	5,970,986 A	10/1999	Bolz et al.
5,311,449 A	5/1994	Adams	5,987,519 A	11/1999	Peifer et al.
5,311,873 A	5/1994	Savard et al.	5,995,939 A	11/1999	Berman et al.
5,321,618 A	6/1994	Gessman	6,001,060 A	12/1999	Churchill et al.
5,330,505 A	7/1994	Cohen	6,006,132 A	12/1999	Tacker, Jr. et al.
5,372,607 A	12/1994	Stone et al.	6,015,388 A	1/2000	Sackner et al.
5,421,830 A	6/1995	Epstein et al.	6,016,442 A	1/2000	Hsu et al.
5,431,691 A	7/1995	Snell et al.	6,016,447 A	1/2000	Juran et al.
5,441,047 A	8/1995	David et al.	6,024,089 A	2/2000	Wallace et al.
5,540,727 A	7/1996	Tockman et al.	6,024,699 A	2/2000	Surwit et al.
5,544,661 A	8/1996	Davis et al.	6,044,299 A	3/2000	Nilsson
5,549,654 A	8/1996	Powell	6,045,513 A	4/2000	Stone et al.
5,576,952 A	11/1996	Stutman et al.	6,070,101 A	5/2000	Struble et al.
5,594,638 A	1/1997	Iliff	6,073,048 A	6/2000	Kieval et al.
5,607,460 A	3/1997	Kroll et al.	6,076,015 A	6/2000	Hartley et al.
5,613,495 A	3/1997	Mills et al.	6,091,990 A	7/2000	Hsu et al.
5,626,630 A	5/1997	Markowitz et al.	6,093,146 A	7/2000	Filangeri
5,630,835 A	5/1997	Brownlee	6,102,874 A	8/2000	Stone et al.
5,690,690 A	11/1997	Nappholz et al.	6,110,522 A	8/2000	Lepper et al.
5,693,076 A	12/1997	Kaemmerer	6,112,224 A	8/2000	Peifer et al.
5,697,959 A	12/1997	Poore	6,115,630 A	9/2000	Stadler et al.
			6,168,563 B1	1/2001	Brown
			6,190,324 B1	2/2001	Kieval et al.
			6,206,829 B1	3/2001	Iliff
			6,240,317 B1	5/2001	Villaseca et al.
			6,249,703 B1	6/2001	Stanton et al.
			6,249,705 B1	6/2001	Snell
			6,250,309 B1	6/2001	Krichen et al.
			6,263,245 B1	7/2001	Snell et al.
			6,275,727 B1	8/2001	Hopper et al.
			6,280,409 B1	8/2001	Stone et al.
			6,304,773 B1	10/2001	Taylor et al.
			6,312,378 B1	11/2001	Bardy
			6,331,160 B1	12/2001	Bardy
			6,336,900 B1	1/2002	Alleckson et al.
			6,336,903 B1	1/2002	Bardy
			6,351,675 B1	2/2002	Tholen et al.
			6,368,284 B1	4/2002	Bardy
			6,370,430 B1 *	4/2002	Mika A61N 1/3627 607/25
			6,381,496 B1	4/2002	Meadows et al.
			6,383,136 B1	5/2002	Jordan
			6,398,728 B1	6/2002	Bardy
			6,411,840 B1	6/2002	Bardy
			6,411,847 B1	6/2002	Mower
			6,416,471 B1	7/2002	Kumar et al.
			6,434,429 B1	8/2002	Kraus et al.
			6,438,407 B1	8/2002	Ousdigian et al.
			6,438,408 B1	8/2002	Mulligan et al.
			6,440,066 B1	8/2002	Bardy
			6,441,747 B1	8/2002	Khair et al.
			6,442,432 B2	8/2002	Lee
			6,442,433 B1	8/2002	Linberg
			6,443,890 B1	9/2002	Schulze et al.
			6,453,201 B1	9/2002	Daum et al.
			6,470,215 B1	10/2002	Kraus et al.
			6,480,733 B1	11/2002	Turcott

(56)

References Cited

U.S. PATENT DOCUMENTS

6,480,745 B2	11/2002	Nelson et al.	7,837,629 B2	11/2010	Bardy
6,490,487 B1	12/2002	Kraus et al.	7,856,035 B2	12/2010	Pierce et al.
6,497,655 B1	12/2002	Linberg et al.	7,860,574 B2	12/2010	Von Arx et al.
6,514,195 B1	2/2003	Ferek	7,959,568 B2	6/2011	Stahmann et al.
6,526,313 B2	2/2003	Sweeney et al.	7,972,275 B2	7/2011	Siejko et al.
6,542,775 B2	4/2003	Ding et al.	7,983,745 B2	7/2011	Hatlestad et al.
6,544,174 B2	4/2003	West et al.	7,983,759 B2	7/2011	Stahmann et al.
RE38,119 E	5/2003	Mower	8,043,213 B2	10/2011	Hatlestad et al.
6,564,104 B2	5/2003	Nelson et al.	8,054,178 B2	11/2011	Mazar et al.
6,564,105 B2	5/2003	Starkweather et al.	8,160,716 B2	4/2012	KenKnight et al.
6,574,503 B2	6/2003	Ferek-Petric	8,301,252 B2	10/2012	Hatlestad et al.
6,579,231 B1	6/2003	Phipps	8,391,989 B2	3/2013	Hatlestad et al.
6,585,644 B2	7/2003	Lebel et al.	8,543,215 B2	9/2013	Hatlestad et al.
6,592,528 B2	7/2003	Amano	8,639,318 B2	1/2014	Hatlestad et al.
6,602,191 B2	8/2003	Quy	8,694,116 B2	4/2014	KenKnight et al.
6,622,045 B2	9/2003	Snell et al.	9,480,848 B2	11/2016	Hatlestad et al.
6,622,048 B1	9/2003	Mann et al.	2001/0007053 A1	7/2001	Bardy
6,628,989 B1	9/2003	Penner et al.	2001/0012955 A1	8/2001	Goedeke et al.
6,643,548 B1	11/2003	Mai et al.	2001/0031997 A1	10/2001	Lee
6,648,823 B2	11/2003	Thompson et al.	2001/0031998 A1	10/2001	Nelson et al.
6,650,939 B2	11/2003	Taepke, II et al.	2001/0039375 A1	11/2001	Lee et al.
6,650,944 B2	11/2003	Goedeke et al.	2001/0039503 A1	11/2001	Chan et al.
6,665,558 B2	12/2003	Kalgren et al.	2001/0047125 A1	11/2001	Quy
6,669,631 B2	12/2003	Norris et al.	2001/0049471 A1	12/2001	Suzuki et al.
6,684,103 B2	1/2004	Ding et al.	2001/0049544 A1	12/2001	Lee
6,687,547 B2	2/2004	Goedeke et al.	2001/0051787 A1	12/2001	Haller et al.
6,735,479 B2*	5/2004	Fabian A61B 5/0031 128/903	2002/0013613 A1	1/2002	Haller et al.
6,738,667 B2	5/2004	Deno et al.	2002/0013614 A1	1/2002	Thompson
6,738,671 B2	5/2004	Christophersom et al.	2002/0016550 A1	2/2002	Sweeney et al.
6,764,446 B2	7/2004	Wolinsky et al.	2002/0019586 A1	2/2002	Teller et al.
6,804,558 B2	10/2004	Haller et al.	2002/0026103 A1	2/2002	Norris et al.
6,811,537 B2	11/2004	Bardy	2002/0026223 A1	2/2002	Riff et al.
6,816,744 B2	11/2004	Garfield et al.	2002/0045808 A1	4/2002	Ford et al.
6,827,670 B1	12/2004	Stark et al.	2002/0049482 A1	4/2002	Fabian et al.
6,834,203 B2	12/2004	Bardy	2002/0052539 A1	5/2002	Haller et al.
6,878,112 B2	4/2005	Linberg et al.	2002/0077562 A1	6/2002	Kalgren et al.
6,920,360 B2	7/2005	Lee et al.	2002/0082665 A1	6/2002	Haller et al.
6,931,273 B2	8/2005	Groenewegen et al.	2002/0082868 A1	6/2002	Pories et al.
6,937,899 B2	8/2005	Sheldon et al.	2002/0103442 A1	8/2002	Mulligan et al.
6,944,495 B2	9/2005	MacAdam et al.	2002/0107641 A1	8/2002	Schaeffer et al.
6,961,617 B1	11/2005	Snell	2002/0115939 A1	8/2002	Mulligan et al.
6,975,900 B2	12/2005	Rudy et al.	2002/0120311 A1	8/2002	Lindh et al.
6,980,851 B2	12/2005	Zhu et al.	2002/0123672 A1	9/2002	Christophersom et al.
7,024,248 B2	4/2006	Penner et al.	2002/0138012 A1	9/2002	Hodges et al.
7,043,305 B2	5/2006	Kenknight et al.	2002/0151938 A1	10/2002	Corbucci
7,047,065 B2	5/2006	Kalgren et al.	2002/0156654 A1	10/2002	Roe et al.
7,054,679 B2	5/2006	Hirsh	2002/0173830 A1	11/2002	Starkweather et al.
7,060,031 B2	6/2006	Webb et al.	2002/0193667 A1	12/2002	McNair
7,070,562 B2	7/2006	Bardy	2002/0193670 A1	12/2002	Garfield et al.
7,115,096 B2	10/2006	Siejko et al.	2003/0050803 A1	3/2003	Marchosky
7,123,953 B2	10/2006	Starobin et al.	2003/0055406 A1	3/2003	Lebel et al.
7,136,705 B1	11/2006	Park	2003/0055679 A1	3/2003	Soll et al.
7,136,707 B2	11/2006	Hall et al.	2003/0074029 A1	4/2003	Deno et al.
7,158,830 B2	1/2007	Yu et al.	2003/0088290 A1	5/2003	Spinelli et al.
7,181,285 B2	2/2007	Lindh et al.	2003/0093125 A1*	5/2003	Zhu A61N 1/3627 607/25
7,203,549 B2	4/2007	Schommer et al.	2003/0093127 A1	5/2003	Dalal
7,209,786 B2	4/2007	Brockway et al.	2003/0144702 A1	7/2003	Yu et al.
7,248,923 B2	7/2007	Maile et al.	2003/0144703 A1	7/2003	Yu et al.
7,273,457 B2	9/2007	Penner	2003/0144711 A1	7/2003	Pless et al.
7,275,220 B2	9/2007	Brummel et al.	2003/0171791 A1	9/2003	KenKnight et al.
RE39,897 E	10/2007	Mower	2003/0204211 A1	10/2003	Condie et al.
7,378,955 B2	5/2008	Mazar et al.	2003/0233031 A1	12/2003	Rice
7,400,928 B2	7/2008	Hatlestad	2003/0235816 A1	12/2003	Slawin et al.
7,429,243 B2	9/2008	KenKnight et al.	2004/0019287 A1	1/2004	White
7,431,699 B2	10/2008	Siejko et al.	2004/0073093 A1	4/2004	Hatlestad
7,468,032 B2	12/2008	Stahmann et al.	2004/0077953 A1*	4/2004	Turcott A61B 5/02028 600/483
7,480,528 B2	1/2009	Brockway et al.	2004/0088192 A1	5/2004	Schmidt et al.
7,554,438 B2	6/2009	Mazar et al.	2004/0117204 A1	6/2004	Mazar et al.
7,559,901 B2	7/2009	Maile et al.	2004/0122294 A1	6/2004	Hatlestad et al.
7,680,534 B2	3/2010	Hopper et al.	2004/0122295 A1	6/2004	Hatlestad et al.
7,751,901 B2	7/2010	Mazar et al.	2004/0122296 A1	6/2004	Hatlestad et al.
7,791,467 B2	9/2010	Mazar et al.	2004/0122297 A1	6/2004	Stahmann et al.
7,805,199 B2	9/2010	KenKnight et al.	2004/0122484 A1	6/2004	Hatlestad et al.
7,831,447 B2	11/2010	Schuman	2004/0122485 A1	6/2004	Stahmann et al.
			2004/0122486 A1	6/2004	Stahmann et al.
			2004/0122487 A1	6/2004	Hatlestad et al.
			2004/0133080 A1	7/2004	Mazar et al.

(56)

References Cited

U.S. PATENT DOCUMENTS

2004/0230456	A1	11/2004	Lozier et al.
2005/0021370	A1	1/2005	Riff et al.
2005/0042589	A1	2/2005	Hatlestad et al.
2006/0195163	A1	8/2006	KenKnight et al.
2006/0253300	A1	11/2006	Somberg et al.
2008/0021287	A1	1/2008	Woellenstein et al.
2008/0027757	A1	1/2008	Mazar et al.
2009/0105554	A1	4/2009	Stahmann et al.
2009/0124917	A1	5/2009	Hatlestad et al.
2009/0273468	A1	11/2009	Mazar et al.
2010/0063840	A1	3/2010	Hoyme et al.
2011/0015701	A1	1/2011	Kenknight et al.
2011/0098588	A1	4/2011	Siejko et al.
2011/0251506	A1	10/2011	Hatlestad et al.
2011/0275941	A1	11/2011	Hatlestad et al.
2011/0275942	A1	11/2011	Stahmann et al.
2012/0044071	A1	2/2012	Mazar et al.
2012/0323289	A1	12/2012	Kenknight et al.
2013/0053706	A1	2/2013	Hatlestad et al.
2013/0158416	A1	6/2013	Hatlestad et al.

FOREIGN PATENT DOCUMENTS

EP	0709058	A1	5/1996
EP	10066698	A2	1/2001
JP	2000123098		4/2000
JP	200167403	A2	3/2001
JP	2001299702	A2	10/2001
JP	2002514454	T	5/2002
JP	2002183312	A2	6/2002
JP	2002311158	A2	10/2002
WO	WO-9914882	A2	3/1999
WO	WO-9958056	A1	11/1999
WO	WO-9958086	A1	11/1999
WO	WO-0041765		7/2000
WO	WO-0041766	A1	7/2000
WO	WO-0103575	A1	1/2001
WO	WO-0124876	A1	4/2001
WO	WO-0167948	A2	9/2001
WO	WO-03075744	A2	9/2003
WO	WO-2004056266	A1	7/2004
WO	WO-2004059551	A2	7/2004
WO	WO-2004104901	A1	12/2004

OTHER PUBLICATIONS

US 7,292,140, 11/2007, Mazar et al. (withdrawn)
 "U.S. Appl. No. 10/323,590, Advisory Action dated Nov. 16, 2006", 3 pgs.
 "U.S. Appl. No. 10/323,590, Final Office Action dated Jul. 10, 2008", 9 pgs.
 "U.S. Appl. No. 10/323,590, Final Office Action dated Aug. 6, 2007", 6 pgs.
 "U.S. Appl. No. 10/323,590, Final Office Action dated Sep. 5, 2006", 5 pgs.
 "U.S. Appl. No. 10/323,590, Non Final Office Action dated Jan. 19, 2006", 5 pgs.
 "U.S. Appl. No. 10/323,590, Non Final Office Action dated Feb. 20, 2007", 4 pgs.
 "U.S. Appl. No. 10/323,590, Non Final Office Action dated Jul. 21, 2005", 6 pgs.
 "U.S. Appl. No. 10/323,590, Non-Final Office Action dated Jan. 9, 2008", 5 pgs.
 "U.S. Appl. No. 10/323,590, Response filed Apr. 9, 2008 to Non-Final Office Action dated Jan. 9, 2008", 19 pgs.
 "U.S. Appl. No. 10/323,590, Response filed May 21, 2007 to Non Final Office Action dated Feb. 20, 2007", 17 pgs.
 "U.S. Appl. No. 10/323,590, Response filed Jun. 19, 2006 to Non Final Office Action dated Jan. 19, 2006", 16 pgs.
 "U.S. Appl. No. 10/323,590, Response filed Oct. 24, 2006 to Final Office Action dated Sep. 5, 2006", 17 pgs.

"U.S. Appl. No. 10/323,590, Response filed Oct. 29, 2007 to Final Office Action dated Aug. 6, 2007", 19 pgs.

"U.S. Appl. No. 10/323,590, Response filed Nov. 2, 2005 to Non Final Office Action dated Jul. 21, 2005", 12 pgs.

"U.S. Appl. No. 11/381,051, Supplemental Preliminary Amendment filed Jul. 31, 2006", 6 pgs.

"U.S. Appl. No. 12/350,875, Notice of Allowance dated Mar. 10, 2011", 5 pgs.

"U.S. Appl. No. 13/185,121, Appeal Decision dated Dec. 23, 2015", 14 pgs.

"U.S. Appl. No. 13/185,121, Final Office Action dated Feb. 6, 2013", 6 pgs.

"U.S. Appl. No. 13/185,121, Non Final Office Action dated Aug. 27, 2012", 6 pgs.

"U.S. Appl. No. 13/185,121, Notice of Allowance dated Jun. 27, 2016", 5 pgs.

"U.S. Appl. No. 13/185,121, Response filed Dec. 27, 2012 to Non Final Office Action dated Aug. 27, 2012", 16 pgs.

"Correlation", [online]. [retrieved Mar. 19, 2007]. Retrieved from the Internet: <URL: <http://everything2.com/index.pl?node=correlation>>, (1999 & 2001), 3 pgs.

"MTWA Testing can determine who should receive ICD", Biotech Equipment Update, 11, Issue 1, (Jan. 1, 2003), 2 pgs.

Anderson, T. W., "R. A. Fisher and multivariate analysis", Statist. Sci., 11(1), (1996), 20-34.

Barbaro, V., et al., "A portable unit for remote monitoring of pacemaker patients", Journal of Telemedicine and Telecare, 3(2), (1997), 96-102.

Bourge, Robert, et al., "Noninvasive Rejection Monitoring of Cardiac Transplants Using High Resolution Intramyocardial Electrograms", PACE, vol. 21, Part II, (Nov. 1998), 2338-2344.

Garson, G. David, "Correlation", Statistics Solutions, Inc. <http://statisticssolutions.com/correlation.htm>, (Copyright 1998, 2006), 12 pgs.

Girouard, Steven D, et al., "Cardiac Rhythm Management Systems and Methods Predicting Congestive Heart Failure Status", U.S. Appl. No. 10/213,268, filed Aug. 6, 2002, 33 pgs.

Hutten, H., et al., "Cardiac pacemaker as bridge to cardiac telemonitoring", Biomedizinische Technik, 41(6), Institut für Elektro-und Biomedizinische Technik Technische Universität Graz., [Article in German With English Abstract], (Jun. 1996), 158-165.

Hutten, H., et al., "Cardiac Telemonitoring through the Linkage of Close-up Telemetry and Internet Transmission", Institute for Electro- and Biomedical Technology, Technical University of Graz Inffeldgasse, 42, [Article in German with English Abstract], (1997), 67-69.

Ji, J., "An Ultraminiature CMOS Pressure Sensor for a Multiplexed Cardiovascular Catheter", IEEE Transactions on Electron Devices, vol. 39, No. 10, (Oct. 1992), pp. 2260-2267.

Kinoshita, O., et al., "T-Wave Alternans in Patients with Right Ventricular Tachycardia", Cardiology, (Abstract Only), (2003), 1 pg.

Lercher, P., et al., "The Impact of the Multicenter Automatic Defibrillator Implantation Trial II in a University Hospital: Do all Patients with Myocardial Infarction and Reduced Left Ventricular Function need an Implantable Cardioverter-Defibrillator?", Wiener Klinische Wochenschrift, 115 (5-6), Abstract in English, (Mar. 31, 2003), 167-174.

Mazar, S. T., et al., "System and Method for Correlating Biometric Trends With a Related Temporal Event", U.S. Appl. No. 10/335,396, 18 pgs.

Moss, A. J, et al., "MADIT-II: Substudies and Their Implications", Cardiac Electrophysiology Review, 7 (4), (Dec. 2003), 430-433.

Moss, A. J, et al., "Prophylactic Implantation of a Defibrillator in Patients with Myocardial Infarction and Reduced Ejection Fraction", The New England Journal of Medicine, 346 (12), (Mar. 21, 2002), 877-883.

Mower, Morton, "Method and Apparatus for Treating Hemodynamic Dysfunction", U.S. Appl. No. 10/214,474.

Nelson, Chester G., et al., "Dynamic Bandwidth Monitor and Adjuster for Remote Communications with a Medical Device", U.S. Appl. No. 60/173,083, filed Dec. 24, 1999, 12 pgs.

Smith, R.A., et al., "An intranet database for pacemaker patients", International Journal of Medical Informatics, 47, (1997), 79-82.

(56)

References Cited

OTHER PUBLICATIONS

Zhu, Qingsheng, et al., "Method and Apparatus for Determining Changes in Heart Failure Status", U.S. Appl. No. 10/001,223, filed Nov. 15, 2001, 22 pgs.

"U.S. Appl. No. 10/093,353, Final Office Action dated Jun. 3, 2005", 11 pgs.

"U.S. Appl. No. 10/093,353, Non Final Office Action dated Nov. 3, 2004", 11 pgs.

"U.S. Appl. No. 10/093,353, Notice of Allowance dated Dec. 13, 2005", 10 pgs.

"U.S. Appl. No. 10/093,353, Response filed Feb. 25, 2005 to Non Final Office Action dated Nov. 3, 2004", 11 pgs.

"U.S. Appl. No. 10/093,353, Response filed Nov. 3, 2005 to Final Office Action dated Jun. 3, 2005", 9 pgs.

"U.S. Appl. No. 10/323,604, Appeal Brief filed Dec. 10, 2009", 54 pgs.

"U.S. Appl. No. 10/323,604, Decision on Appeal dated Jun. 6, 2012", 15 pgs.

"U.S. Appl. No. 10/323,604, Decision on Pre-Appeal Brief Request dated Nov. 10, 2009", 2 pgs.

"U.S. Appl. No. 10/323,604, Examiner's Answer to Appeal Brief dated Aug. 6, 2010", 21 pgs.

"U.S. Appl. No. 10/323,604, Final Office Action dated Feb. 12, 2007", 13 pgs.

"U.S. Appl. No. 10/323,604, Final Office Action dated Aug. 19, 2008", 16 pgs.

"U.S. Appl. No. 10/323,604, Non-Final Office Action dated Apr. 21, 2009", 20 pgs.

"U.S. Appl. No. 10/323,604, Non-Final Office Action dated Aug. 8, 2007", 13 pgs.

"U.S. Appl. No. 10/323,604, Non-Final Office Action dated Dec. 30, 2005", 15 pgs.

"U.S. Appl. No. 10/323,604, Notice of Allowance dated Aug. 10, 2012", 7 pgs.

"U.S. Appl. No. 10/323,604, Notice of Non-Compliant Brief dated Jan. 11, 2010", 2 pgs.

"U.S. Appl. No. 10/323,604, Pre-Appeal Request filed Aug. 20, 2009", 5 pgs.

"U.S. Appl. No. 10/323,604, Reply Brief filed Oct. 5, 2010", 7 pgs.

"U.S. Appl. No. 10/323,604, Response filed Jan. 8, 2008 to Non-Final Office Action dated Aug. 8, 2007", 17 pgs.

"U.S. Appl. No. 10/323,604, Response filed Feb. 19, 2009 to Final Office Action dated Aug. 19, 2008", 14 pgs.

"U.S. Appl. No. 10/323,604, Response filed May 30, 2007 to Final Office Action dated Feb. 12, 2007", 17 pgs.

"U.S. Appl. No. 10/323,604, Response filed Jun. 30, 2006 to Restriction Requirement dated Dec. 30, 2005", 20 pgs.

"U.S. Appl. No. 10/323,604, Response filed Jan. 8, 2008 to Office Action dated Aug. 8, 2007", 17 pgs.

"U.S. Appl. No. 10/323,604, Response to Notice of Non-Compliant Brief filed Feb. 11, 2010", 56 pgs.

"U.S. Appl. No. 10/323,604, Supplemental Notice of Allowability dated Nov. 5, 2012", 2 pgs.

"U.S. Appl. No. 10/323,616, Final Office Action dated Oct. 31, 2007", 20 pgs.

"U.S. Appl. No. 10/323,713, Advisory Action dated Jan. 31, 2007", 3 pgs.

"U.S. Appl. No. 10/323,713, Final Office Action dated Apr. 4, 2008", 16 pgs.

"U.S. Appl. No. 10/323,713, Final Office Action dated Nov. 8, 2006", 12 pgs.

"U.S. Appl. No. 10/323,713, Non Final Office Action dated Apr. 10, 2007", 13 pgs.

"U.S. Appl. No. 10/323,713, Non Final Office Action dated Dec. 9, 2005", 10 pgs.

"U.S. Appl. No. 10/323,713, Non-Final Office Action dated Jun. 21, 2006", 11 pgs.

"U.S. Appl. No. 10/323,713, Non-Final Office Action dated Sep. 28, 2007", 15 pgs.

"U.S. Appl. No. 10/323,713, Notice of Allowance dated Aug. 20, 2008", 9 pgs.

"U.S. Appl. No. 10/323,713, Preliminary Amendment dated Dec. 17, 2003", 14 pgs.

"U.S. Appl. No. 10/323,713, Response filed Jan. 8, 2007 to Final Office Action dated Nov. 8, 2006", 17 pgs.

"U.S. Appl. No. 10/323,713, Response filed Mar. 26, 2007 to Final Office Action dated Nov. 8, 2006", 15 pgs.

"U.S. Appl. No. 10/323,713, Response filed Apr. 18, 2006 to Non Final Office Action dated Dec. 9, 2005", 15 pgs.

"U.S. Appl. No. 10/323,713, Response filed Jul. 10, 2007 to Non-Final Office Action dated Apr. 10, 2007", 18 pgs.

"U.S. Appl. No. 10/323,713, Response filed Jul. 30, 2008 to Final Office Action dated Apr. 4, 2008", 11 pgs.

"U.S. Appl. No. 10/323,713, Response filed Sep. 21, 2006 to Non Final Office Action dated Jun. 21, 2006", 14 pgs.

"U.S. Appl. No. 10/323,713, Response filed Dec. 28, 2007 to Non-Final Office Action dated Sep. 28, 2007", 19 pgs.

"U.S. Appl. No. 10/323,850, Response filed Nov. 21, 2016 to Non Final Office Action dated Jul. 20, 2016", 21 pgs.

"U.S. Appl. No. 10/323,859, Advisory Action dated Jun. 23, 2017", 3 pgs.

"U.S. Appl. No. 10/323,859, Advisory Action dated Aug. 29, 2011", 3 pgs.

"U.S. Appl. No. 10/323,859, Appeal Brief Under 37 CFR 41.37", 43 pgs.

"U.S. Appl. No. 10/323,859, Appeal Decision dated Oct. 9, 2015", 11 pgs.

"U.S. Appl. No. 10/323,859, Decision on Pre-Appeal Brief dated Jan. 11, 2012", 2 pgs.

"U.S. Appl. No. 10/323,859, Decision on Pre-Appeal Brief Request dated Jan. 14, 2010", 2 pgs.

"U.S. Appl. No. 10/323,859, Examiner's Answer to Appeal Brief dated Aug. 3, 2012", 17 pgs.

"U.S. Appl. No. 10/323,859, Final Office Action dated Mar. 24, 2017", 5 pgs.

"U.S. Appl. No. 10/323,859, Final Office Action dated May 10, 2011", 20 pgs.

"U.S. Appl. No. 10/323,859, Final Office Action dated Jun. 18, 2007", 8 pgs.

"U.S. Appl. No. 10/323,859, Final Office Action dated Jul. 9, 2009", 9 pgs.

"U.S. Appl. No. 10/323,859, Non-Final Office Action dated Mar. 29, 2006", 8 pgs.

"U.S. Appl. No. 10/323,859, Non-Final Office Action dated Jul. 20, 2016", 16 pgs.

"U.S. Appl. No. 10/323,859, Non-Final Office Action dated Oct. 17, 2008", 7 pgs.

"U.S. Appl. No. 10/323,859, Non-Final Office Action dated Nov. 26, 2010", 14 pgs.

"U.S. Appl. No. 10/323,859, Pre-Appeal Brief Request filed Aug. 31, 2011", 5 pgs.

"U.S. Appl. No. 10/323,859, Pre-Appeal Brief Request filed Dec. 9, 2009", 5 pgs.

"U.S. Appl. No. 10/323,859, Response filed Aug. 24, 2017 to Final Office Action dated Mar. 24, 2017", 21 pgs.

"U.S. Appl. No. 10/323,859, Response filed Feb. 28, 2011 to Non-Final Office Action dated Nov. 26, 2010", 19 pgs.

"U.S. Appl. No. 10/323,859, Response filed Mar. 17, 2009 to Non-Final Office Action dated Oct. 17, 2008", 20 pgs.

"U.S. Appl. No. 10/323,859, Response filed May 23, 2017 to Final Office Action dated Mar. 24, 2017", 22 pgs.

"U.S. Appl. No. 10/323,859, Response filed Jul. 11, 2011 to Final Office Action dated May 10, 2011", 23 pgs.

"U.S. Appl. No. 10/323,859, Response filed Aug. 20, 2007 to Final Office Action dated Jun. 18, 2007", 17 pgs.

"U.S. Appl. No. 10/323,859, Response filed Sep. 28, 2006 to Non Final office action dated Mar. 29, 2006", 14 pgs.

"U.S. Appl. No. 10/323,860, Advisory Action dated Jun. 20, 2007", 4 pgs.

"U.S. Appl. No. 10/323,860, Advisory Action dated Aug. 19, 2009", 3 pgs.

(56)

References Cited

OTHER PUBLICATIONS

"U.S. Appl. No. 10/323,860, Appeal Brief filed Dec. 11, 2007", 33 pgs.
 "U.S. Appl. No. 10/323,860, Decision on Pre-Appeal Brief Request dated Aug. 1, 2007", 2 pgs.
 "U.S. Appl. No. 10/323,860, Examiner Interview Summary dated May 23, 2008", 2 pgs.
 "U.S. Appl. No. 10/323,860, Examiner Interview Summary dated Nov. 5, 2008", 2 pgs.
 "U.S. Appl. No. 10/323,860, Final Office Action dated Feb. 17, 2011", 7 pgs.
 "U.S. Appl. No. 10/323,860, Final Office Action dated Mar. 5, 2009", 12 pgs.
 "U.S. Appl. No. 10/323,860, Final Office Action dated Mar. 20, 2008", 11 pgs.
 "U.S. Appl. No. 10/323,860, Final Office Action dated Apr. 11, 2007", 9 pgs.
 "U.S. Appl. No. 10/323,860, Final Office Action dated Apr. 29, 2010", 11 pgs.
 "U.S. Appl. No. 10/323,860, Non-Final Office Action dated Mar. 2, 2006", 8 pgs.
 "U.S. Appl. No. 10/323,860, Non-Final Office Action dated Jul. 22, 2008", 11 pgs.
 "U.S. Appl. No. 10/323,860, Non-Final Office Action dated Aug. 4, 2010", 5 pgs.
 "U.S. Appl. No. 10/323,860, Non-Final Office Action dated Sep. 28, 2006", 12 pgs.
 "U.S. Appl. No. 10/323,860, Non-Final Office Action dated Oct. 28, 2009", 10 pgs.
 "U.S. Appl. No. 10/323,860, Pre-Appeal Brief Request filed Jul. 11, 2007", 5 pgs.
 "U.S. Appl. No. 10/323,860, Response filed Jan. 28, 2010 to Non Final Office Action dated Oct. 28, 2009", 12 pgs.
 "U.S. Appl. No. 10/323,860, Response filed Jan. 29, 2007 to Non-Final Office Action dated Sep. 28, 2006", 15 pgs.
 "U.S. Appl. No. 10/323,860, Response filed Jun. 2, 2006 to Non-Final Office Action dated Mar. 2, 2006", 12 pgs.
 "U.S. Appl. No. 10/323,860, Response filed Jun. 11, 2007 to Final Office Action dated Apr. 11, 2007", 13 pgs.
 "U.S. Appl. No. 10/323,860, Response filed Jun. 20, 2008 to Final Office Action dated Mar. 20, 2008", 18 pgs.
 "U.S. Appl. No. 10/323,860, Response filed Jun. 28, 2010 to Final Office Action dated Apr. 29, 2010", 11 pgs.
 "U.S. Appl. No. 10/323,860, Response filed Aug. 4, 2009 to Final Office Action dated Mar. 5, 2009", 14 pgs.
 "U.S. Appl. No. 10/323,860, Response filed Aug. 31, 2009 to Advisory Action dated Aug. 19, 2009", 16 pgs.
 "U.S. Appl. No. 10/323,860, Response filed Nov. 24, 2008 to Non Final Office Action dated Jul. 22, 2008", 17 pgs.
 "U.S. Appl. No. 10/323,860, Response filed Dec. 6, 2010 to Non Final Office Action dated Aug. 4, 2010", 14 pgs.
 "U.S. Appl. No. 10/335,396, Notice of Allowance dated Nov. 30, 2007", 7 pgs.
 "U.S. Appl. No. 10/335,396, Supplemental Notice of Allowability dated Dec. 26, 2007", 5 pgs.
 "U.S. Appl. No. 11/381,051, Non-Final Office Action dated Mar. 19, 2008", 14 pgs.
 "U.S. Appl. No. 11/381,051, Non-Final Office Action dated Oct. 22, 2008", 13 pgs.
 "U.S. Appl. No. 11/381,051, Notice of Allowance dated May 18, 10", 6 pgs.
 "U.S. Appl. No. 11/381,051, Notice of Allowance dated Jun. 2, 2009", 8 pgs.
 "U.S. Appl. No. 11/381,051, Notice of Allowance dated Dec. 18, 2009", 8 pgs.
 "U.S. Appl. No. 11/381,051, Preliminary Amendment filed May 1, 2006", 5 pgs.
 "U.S. Appl. No. 11/381,051, Response filed Feb. 23, 2009 to Non-Final Office Action dated Oct. 22, 2008", 11 pgs.

"U.S. Appl. No. 11/381,051, Response filed Aug. 18, 2008 to Non-Final Office Action dated Mar. 19, 2008", 7 pgs.
 "U.S. Appl. No. 11/869,611, Non-Final Office Action dated Dec. 23, 2008", 6 pgs.
 "U.S. Appl. No. 11/869,611, Notice of Allowance dated Mar. 5, 2009", 6 pgs.
 "U.S. Appl. No. 11/869,611, Response filed Jan. 27, 2009 to Non Final Office Action dated Dec. 23, 2008", 8 pgs.
 "U.S. Appl. No. 12/341,207, Notice of Allowance dated Feb. 7, 2011", 10 pgs.
 "U.S. Appl. No. 12/341,207, Preliminary Amendment dated Jan. 25, 2011", 6 pgs.
 "U.S. Appl. No. 12/476,833, Non Final Office Action dated Dec. 22, 2010", 11 pgs.
 "U.S. Appl. No. 12/476,833, Notice of Allowance dated May 6, 2011", 9 pgs.
 "U.S. Appl. No. 12/476,833, Notice of Allowance dated Sep. 19, 2011", 9 pgs.
 "U.S. Appl. No. 12/476,833, Response filed Mar. 4, 2011 to Non Final Office Action dated Dec. 22, 2010", 9 pgs.
 "U.S. Appl. No. 12/891,338, Notice of Allowance dated Dec. 7, 2011", 10 pgs.
 "U.S. Appl. No. 13/162,311, 312 Amendment filed Oct. 2, 2012", 2 pgs.
 "U.S. Appl. No. 13/162,311, Final Office Action dated Apr. 13, 2012", 7 pgs.
 "U.S. Appl. No. 13/162,311, Non Final Office Action dated Oct. 13, 2011", 10 pgs.
 "U.S. Appl. No. 13/162,311, Notice of Allowance dated Jun. 22, 2012", 8 pgs.
 "U.S. Appl. No. 13/162,311, Response filed Feb. 13, 2012 to Non Final Office Action dated Oct. 13, 2011", 13 pgs.
 "U.S. Appl. No. 13/162,311, Response filed Jun. 13, 2012 to Final Office Action dated Apr. 13, 2012", 9 pgs.
 "U.S. Appl. No. 13/284,105, Non Final Office Action dated Feb. 7, 2012", 8 pgs.
 "U.S. Appl. No. 13/447,816, Non Final Office Action dated Jun. 20, 2013", 14 pgs.
 "U.S. Appl. No. 13/447,816, Notice of Allowance dated Nov. 18, 2013", 11 pgs.
 "U.S. Appl. No. 13/447,816, Preliminary Amendment filed Sep. 4, 2012", 7 pgs.
 "U.S. Appl. No. 13/447,816, Response filed Sep. 19, 2013 to Non Final Office Action dated Jun. 20, 2013", 10 pgs.
 "U.S. Appl. No. 13/663,309, Non Final Office Action dated Jan. 18, 2013", 7 pgs.
 "U.S. Appl. No. 13/663,309, Non Final Office Action dated May 28, 2013", 7 pgs.
 "U.S. Appl. No. 13/663,309, Notice of Allowability dated Nov. 25, 2013", 5 pgs.
 "U.S. Appl. No. 13/663,309, Notice of Allowance dated Sep. 27, 2013", 9 pgs.
 "U.S. Appl. No. 13/663,309, Response filed Apr. 18, 2013 to Non Final Office Action dated Jan. 18, 2013", 9 pgs.
 "U.S. Appl. No. 13/663,309, Response filed Aug. 19, 2013 to Non Final Office Action dated May 28, 2013", 7 pgs.
 "U.S. Appl. No. 13/769,737, Notice of Allowance dated May 15, 2013", 12 pgs.
 "U.S. Appl. No. 13/769,737, Supplemental Notice of Allowability dated Aug. 20, 2013", 2 pgs.
 "U.S. Appl. No. 13/769,737, Supplemental Notice of Allowability dated Aug. 26, 2013", 2 pgs.
 "European Application Serial No. 03713931, Office Action dated Jul. 22, 2008", 4 pgs.
 "European Application Serial No. 03713931.8, Communication dated Feb. 3, 2005", 2 pgs.
 "European Application Serial No. 03713931.8, Office Action dated May 20, 2009", 2 pgs.
 "European Application Serial No. 03713931.8, Response filed Jan. 15, 2009 to Communication dated Jul. 22, 2008", 17 pgs.
 "European Application Serial No. 03713931.8, Response filed Mar. 3, 2005 to Communication dated Feb. 3, 2005", 6 pgs.

(56)

References Cited

OTHER PUBLICATIONS

"European Application Serial No. 03713931.8, Response filed Sep. 18, 2009 to Communication dated May 20, 2009", 4 pgs.
"European Application Serial No. 03813800.4, Office Action dated Feb. 3, 2011", 6 pgs.
"European Application Serial No. 03814044.8, Communication dated Apr. 21, 2008", 3 pgs.
"European Application Serial No. 03814044.8, Communication dated Apr. 21, 2008", 7 pgs.
"European Application Serial No. 03814044.8, Response filed Oct. 20, 2008 to Communication dated Apr. 21, 2008", 14 pgs.
"International Application Serial No. PCT/US 03/40034, International Search Report dated Apr. 4, 2005", 3 pgs.
"International Application Serial No. PCT/US03/06851, International Search Report dated Nov. 25, 2004", 4 pgs.
"International Application Serial No. PCT/US2003/040034, International Search Report dated Apr. 4, 2005", 3 pgs.
"International Application Serial No. PCT/US2003/040662, International Search Report dated May 28, 2004", 6 pgs.
"International Search Report for corresponding PCT Application No. PCT/US 03/06851", (dated Nov. 25, 2004), 4 Pages.
"Japanese Application Serial No. 2004-562326, Office Action dated Feb. 3, 2010", (w/ English Translation), 7 pgs.
"Japanese Application Serial No. 2004-562326, Office Action dated Feb. 24, 2011", (w/ English Translation), 7 pgs.
"Japanese Application Serial No. 2004-562326, Response filed May 2, 2011 to Office Action dated Feb. 4, 2011", (w/ English Translation of Amended Claims), 8 pgs.

"Japanese Application Serial No. 2004-562326, Response filed Aug. 2, 2010 to Office Action dated Feb. 3, 2010", (w/ English Translation of Amended Claims), 13 pgs.

"Japanese Application Serial No. 2004-563613, Amendment filed Mar. 2, 2010 to Notice of Reasons for Rejection dated Dec. 3, 2009", (w/ English Translation of Amended Claims), 11 pgs.

"Japanese Application Serial No. 2004-563613, Notice of Allowance dated May 20, 2011", 3 Pgs.

"Japanese Application Serial No. 2004-563613, Notice of Reasons for Rejection dated Dec. 3, 2009", (w/ English Translation), 7 pgs.

"Japanese Application Serial No. 2004-563613, Office Action dated Jul. 14, 2010", (w/ English Translation), 5 pgs.

"Japanese Application Serial No. 2004-563613, Response filed Jan. 12, 2011 to Office Action dated Jul. 14, 2010", 5 pgs.

Hatlestad, John, "Methods and Devices for Detection of Context When Addressing a Medical Condition of a Patient", U.S. Appl. No. 10/269,611, filed Oct. 11, 2002, 29 pgs.

Kenknight, Bruce H, et al., "Method and Apparatus for Establishing Context Among Events and Optimizing Implanted Medical Device Performance", U.S. Appl. No. 10/093,353, filed Mar. 6, 2002, 43 pgs.

Kenknight, Bruce H, "Method and Apparatus for Establishing Context Among Events and Optimizing Implanted Medical Device Performance", U.S. Appl. No. 11/381,051, filed May 1, 2006, 44 pgs.

Lozier, Luke R, et al., "System for Identifying Candidates for ICD Implantation", U.S. Appl. No. 10/438,261, filed May 14, 2003, 15 pgs.

* cited by examiner

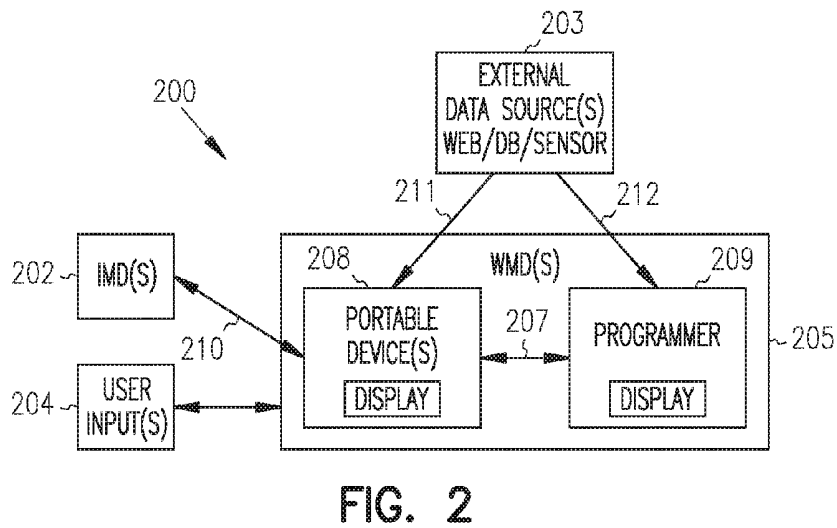
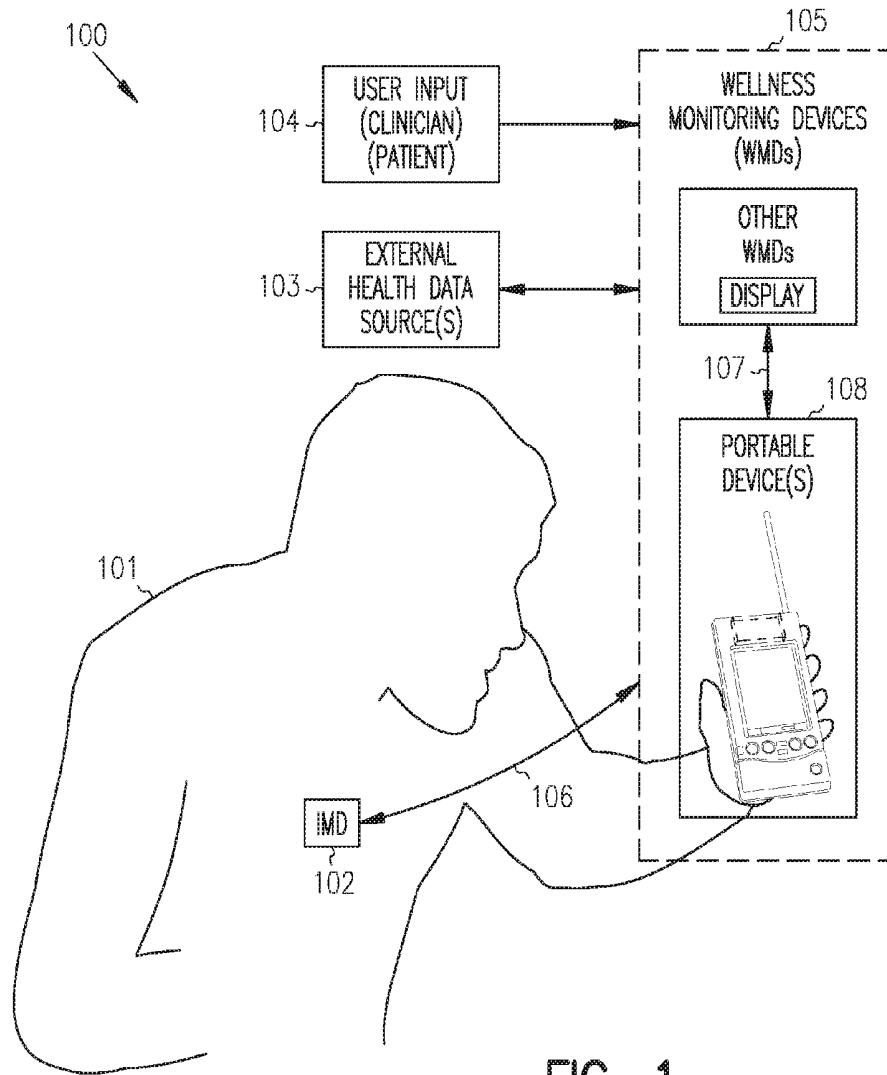

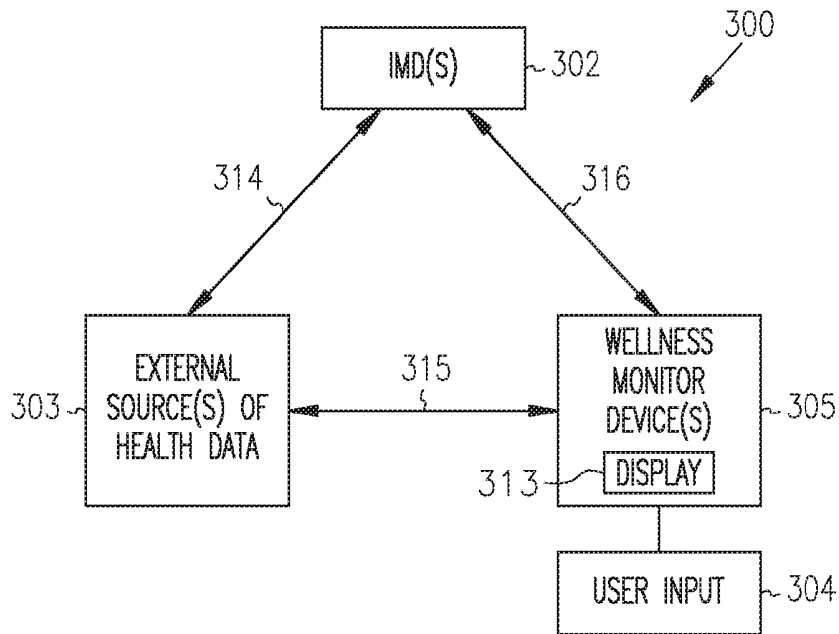

FIG. 3

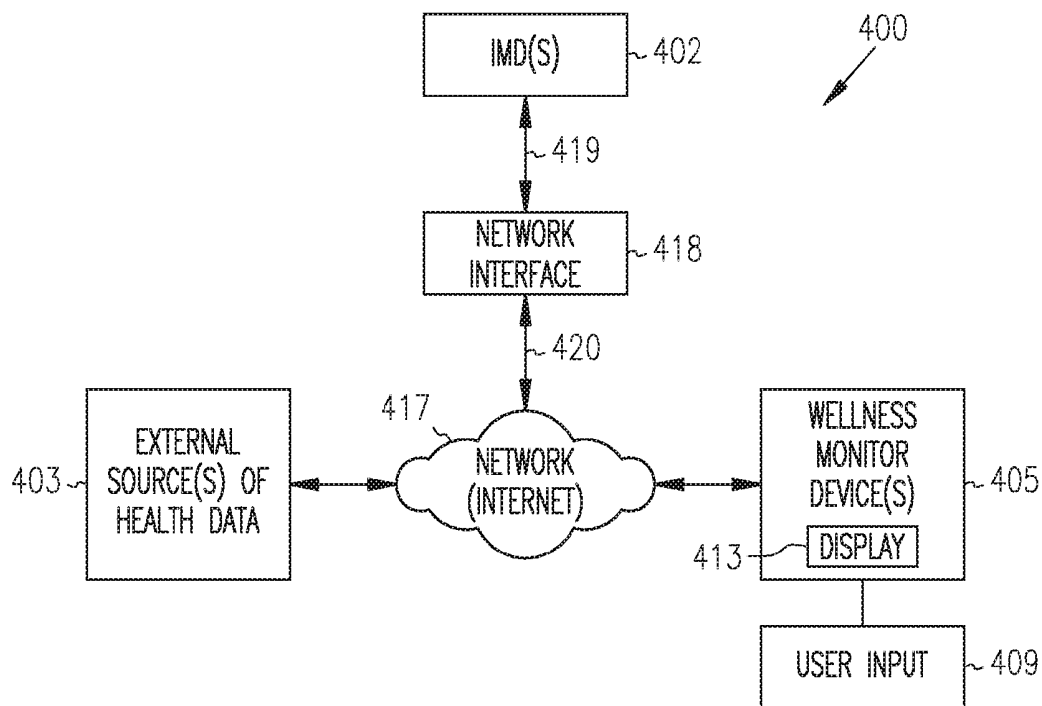

FIG. 4

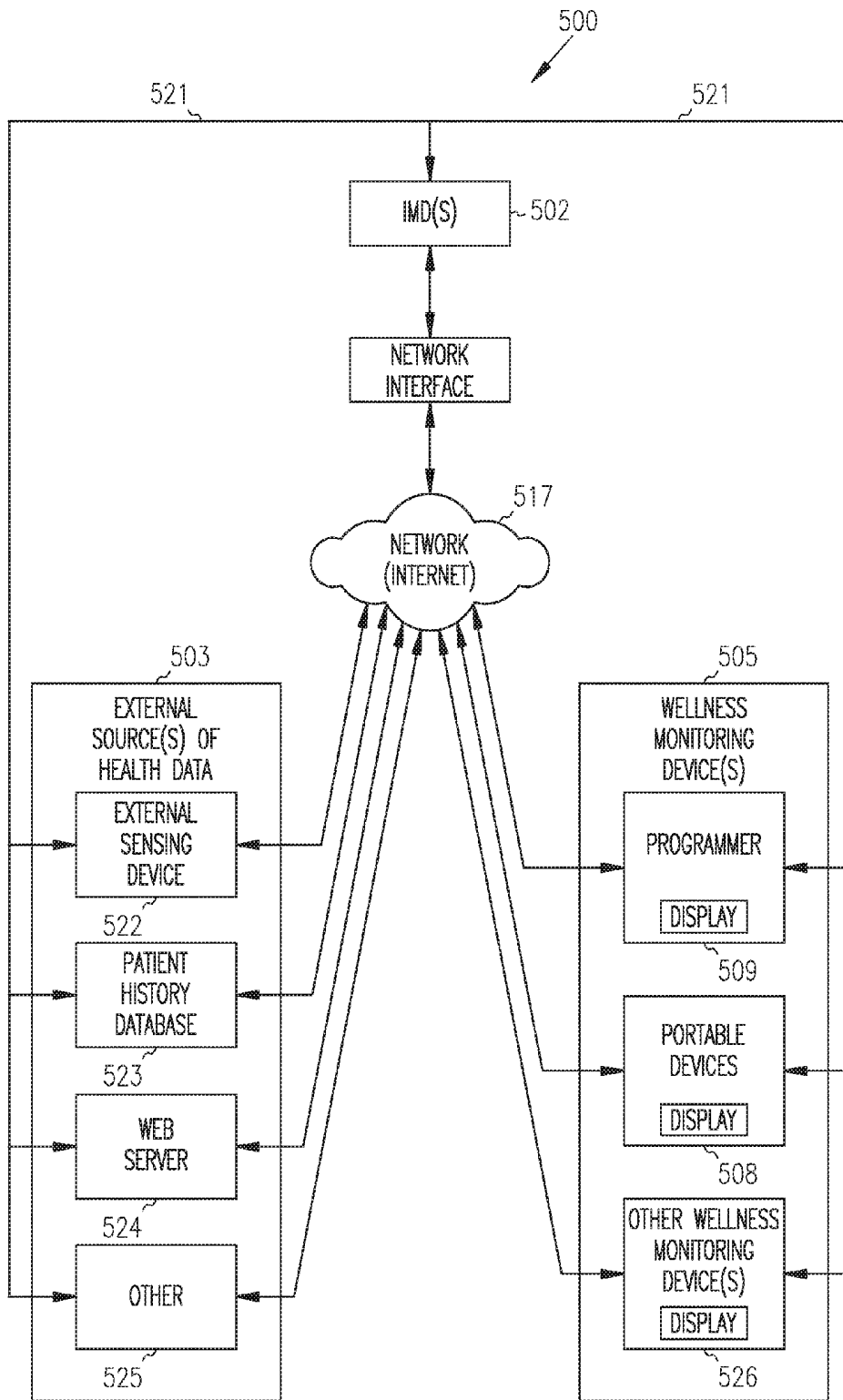

FIG. 5

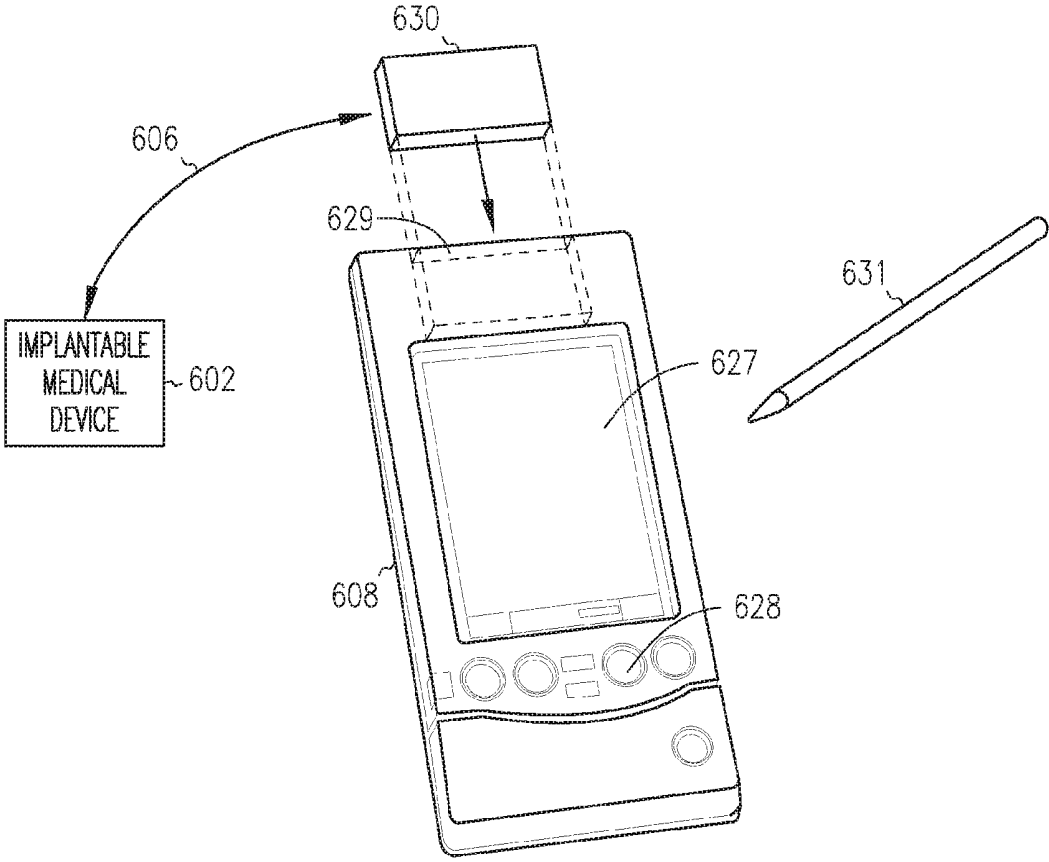

FIG. 6

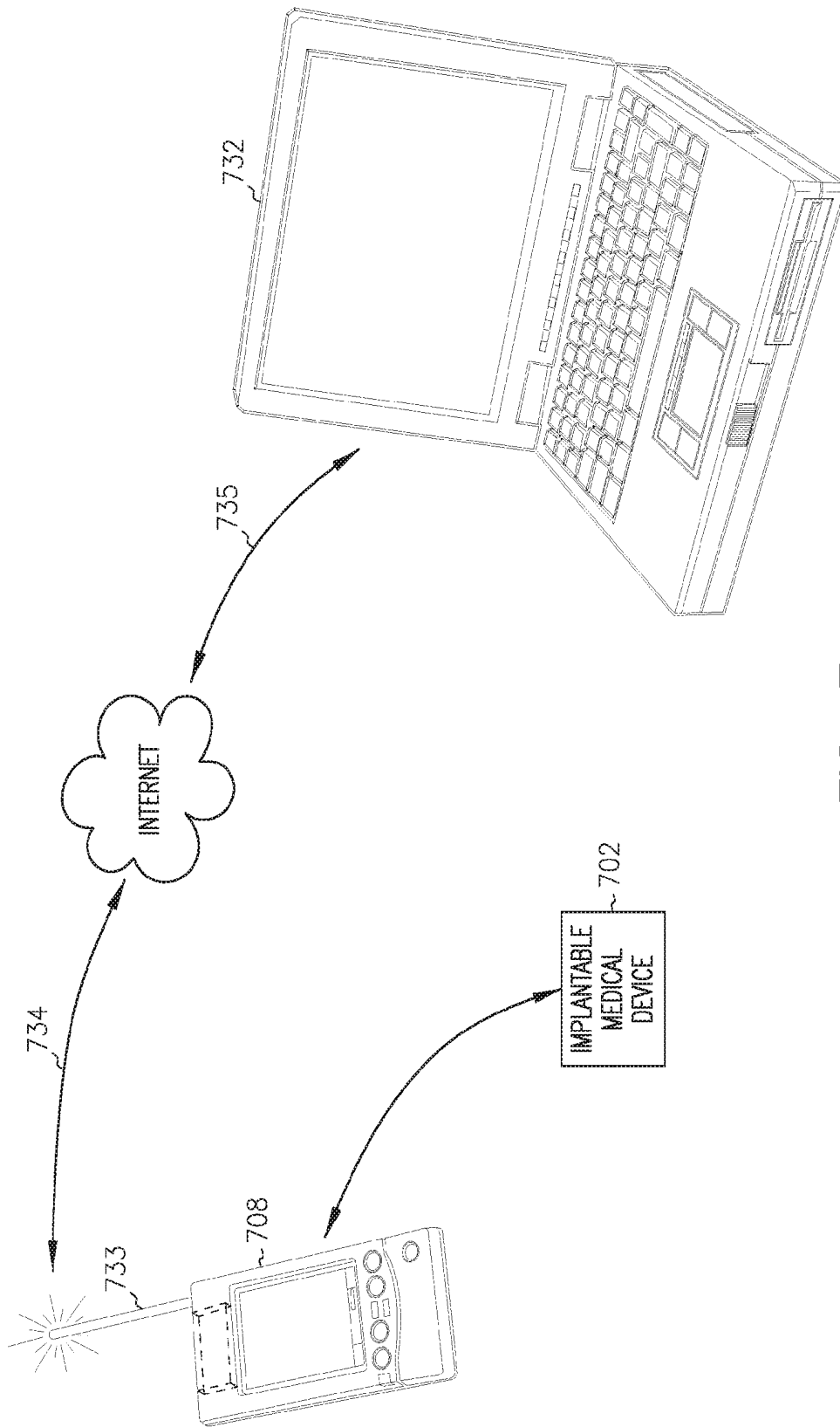

FIG. 7

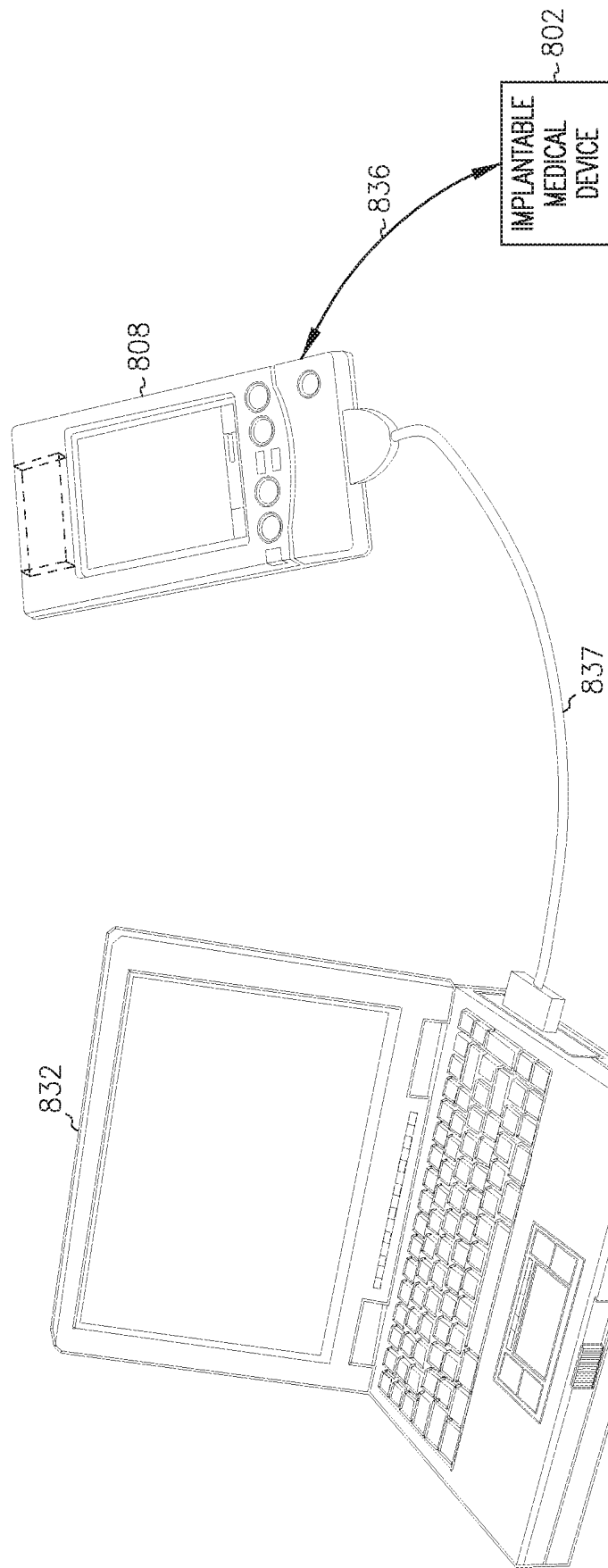

FIG. 8

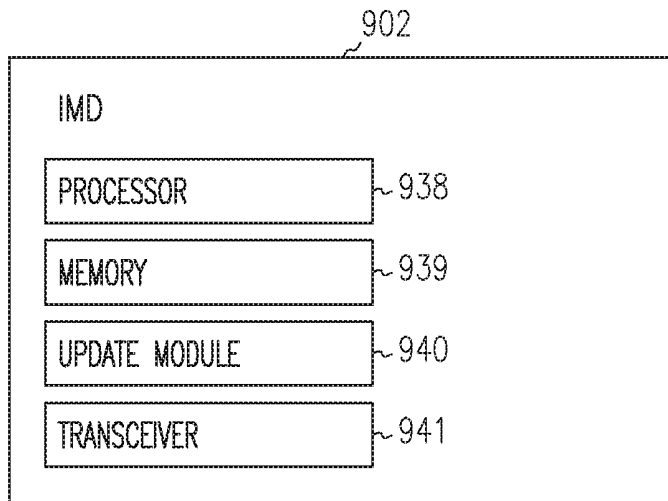

FIG. 9

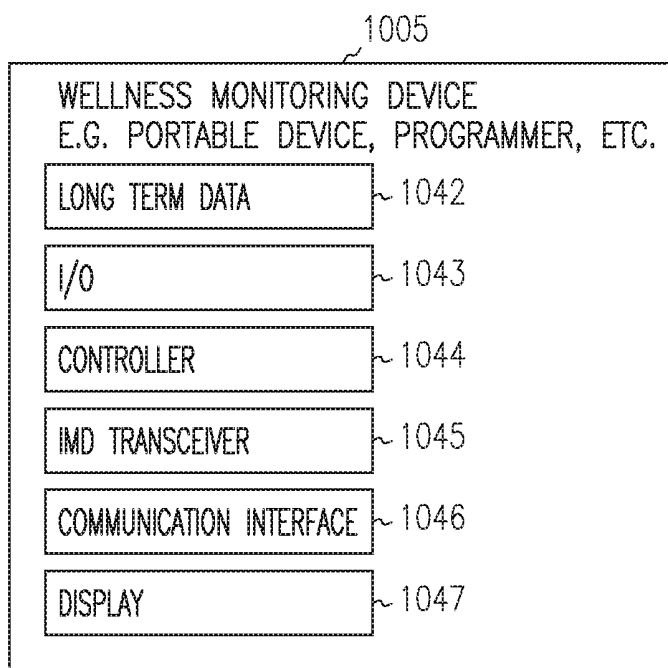

FIG. 10

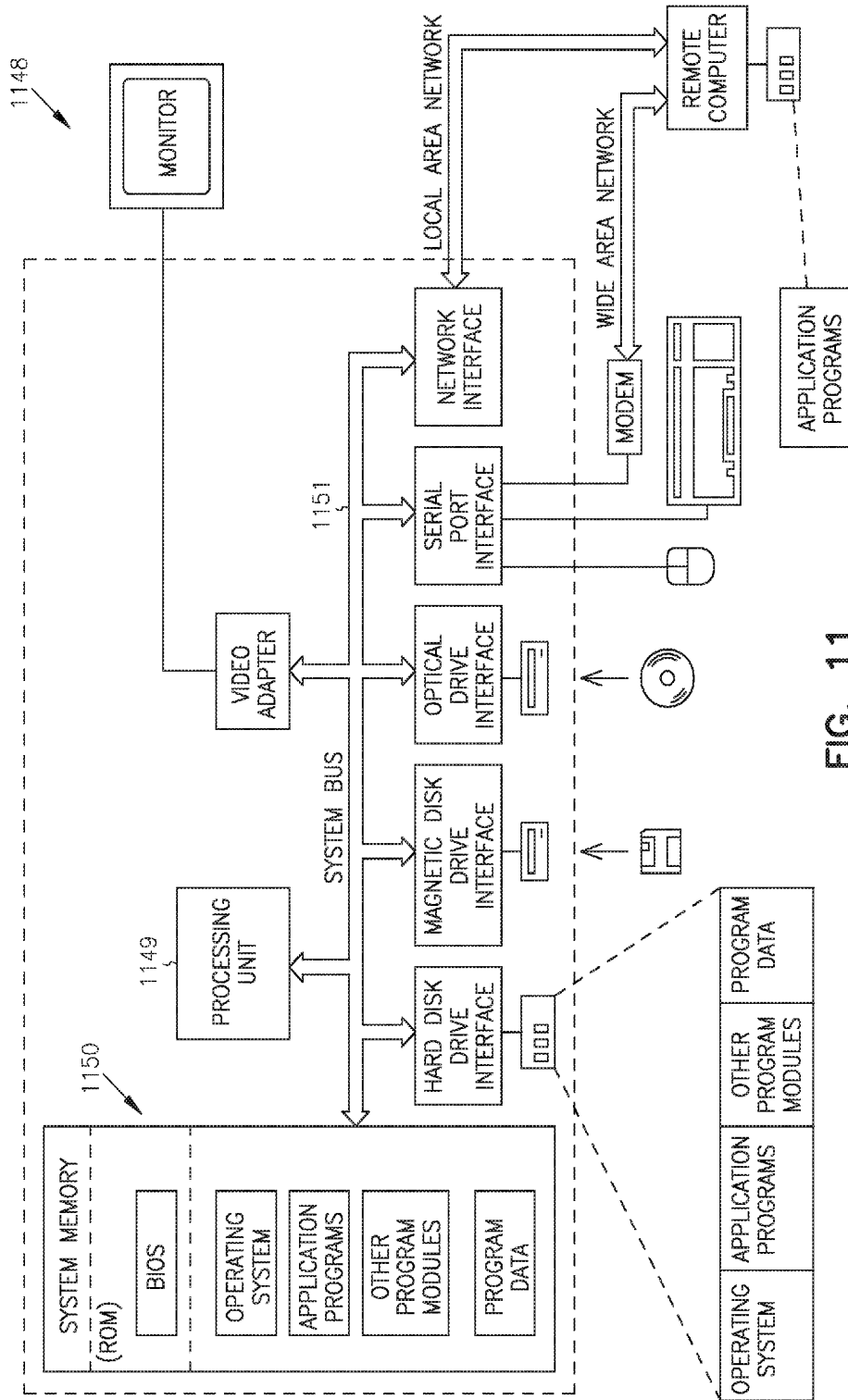

FIG. 11

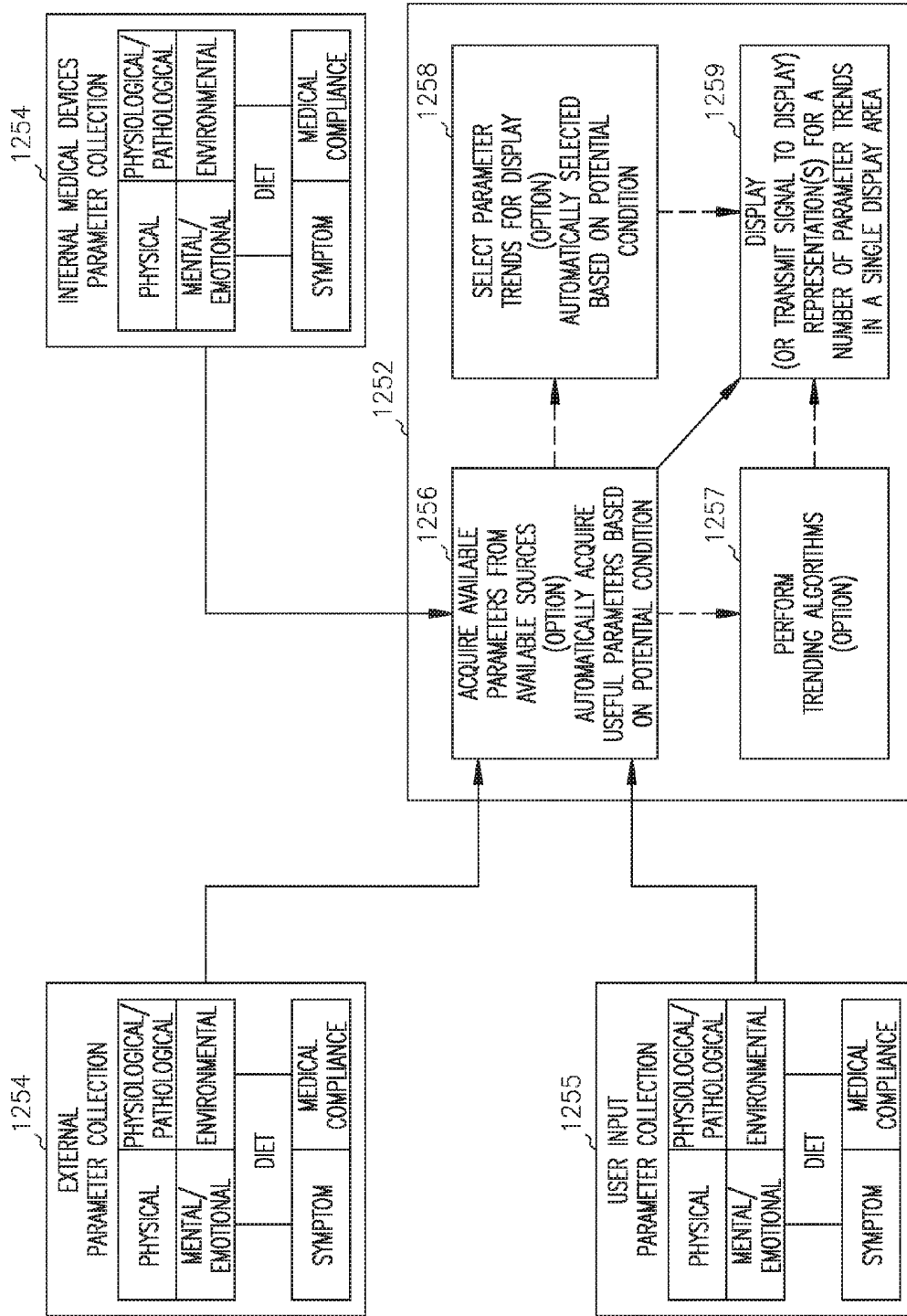

FIG. 12

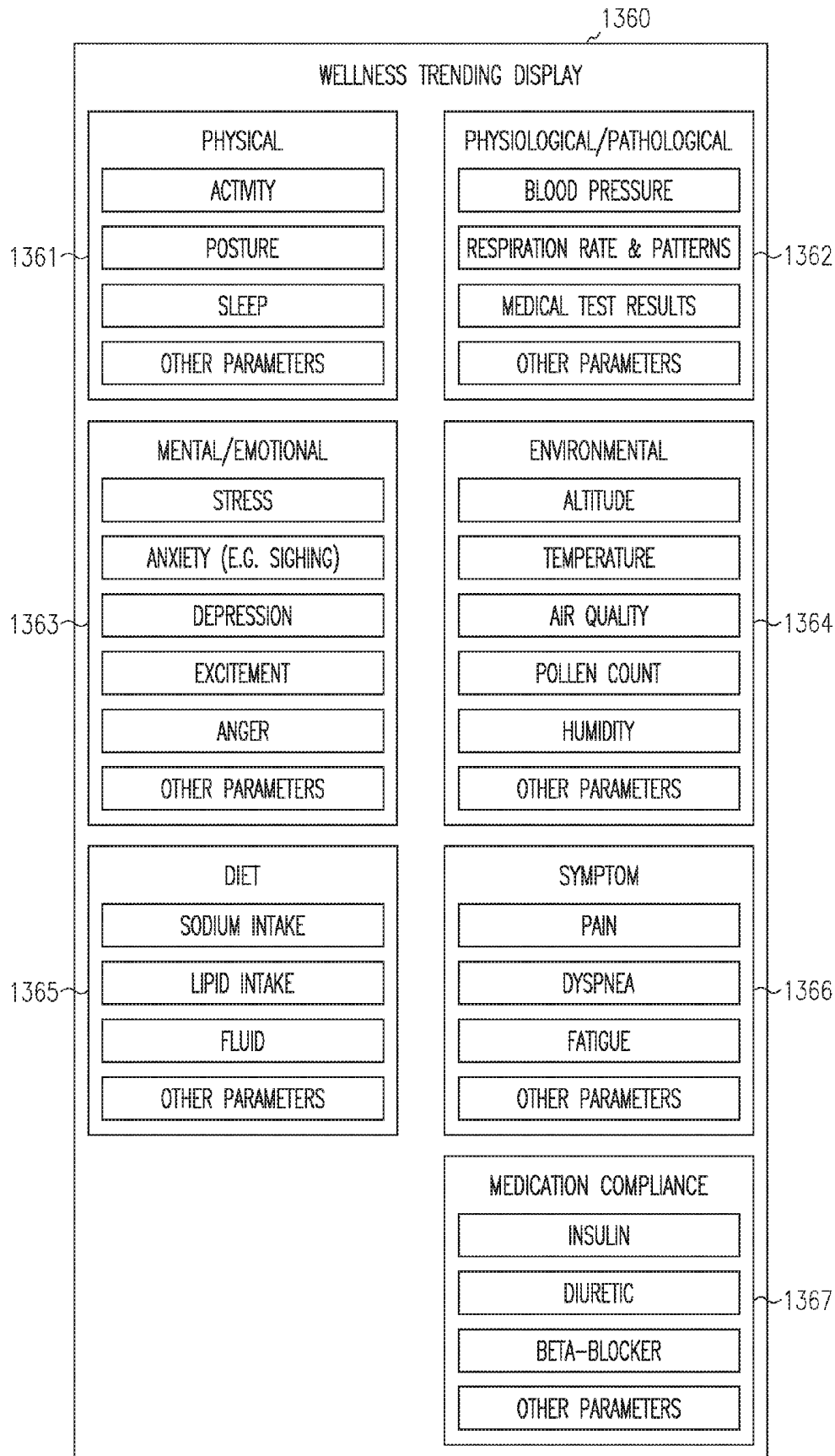

FIG. 13

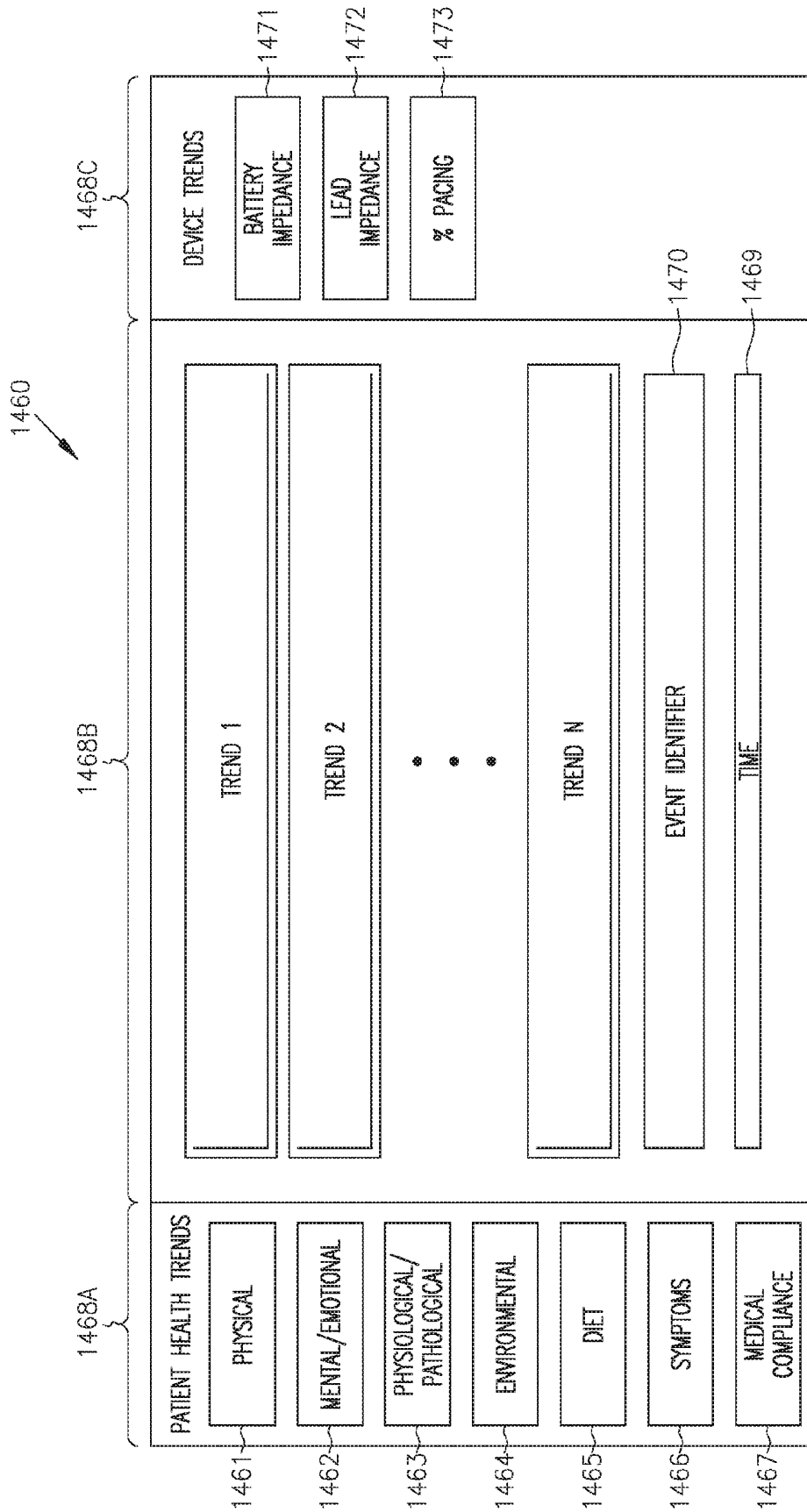

FIG. 14

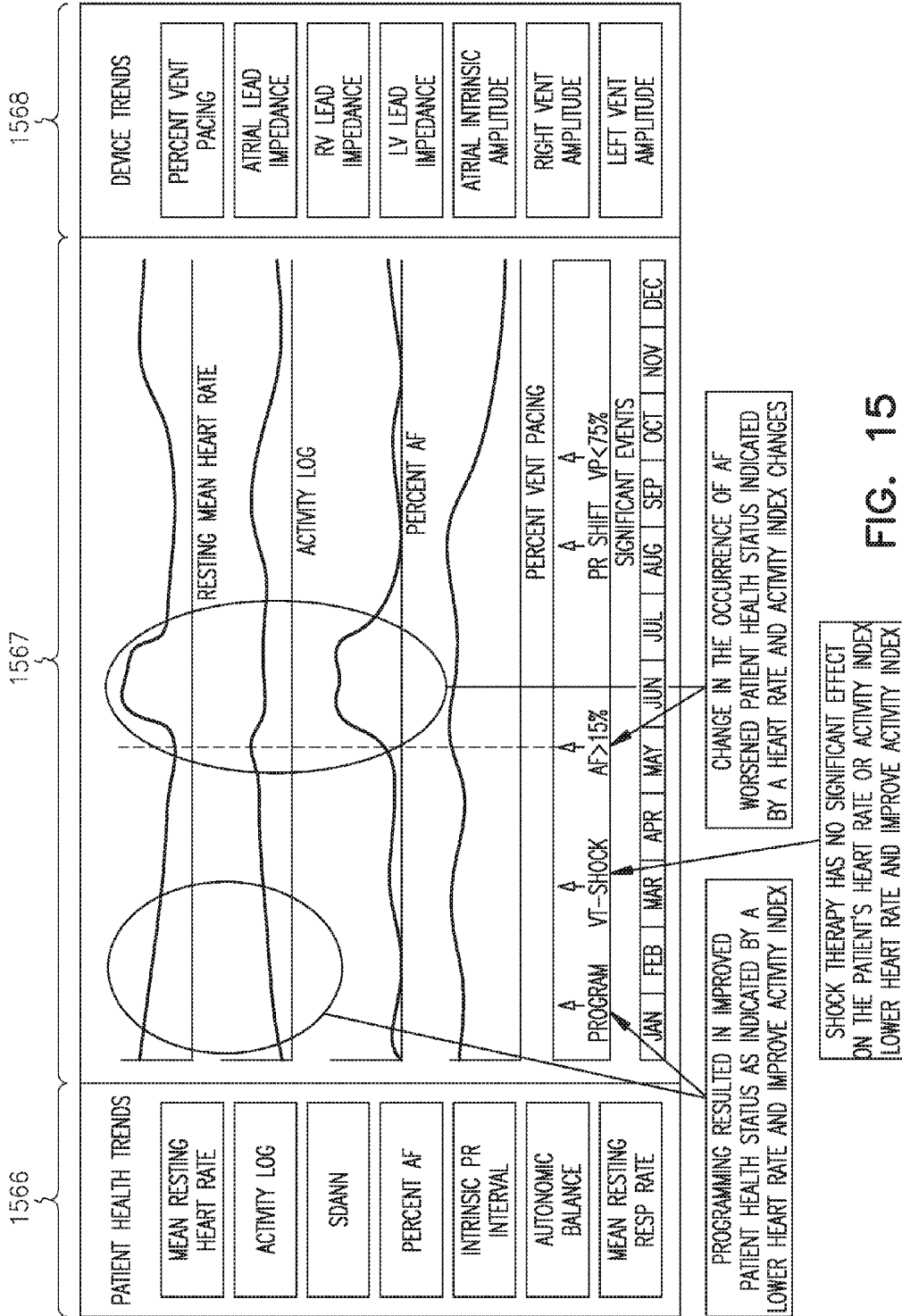

FIG. 15

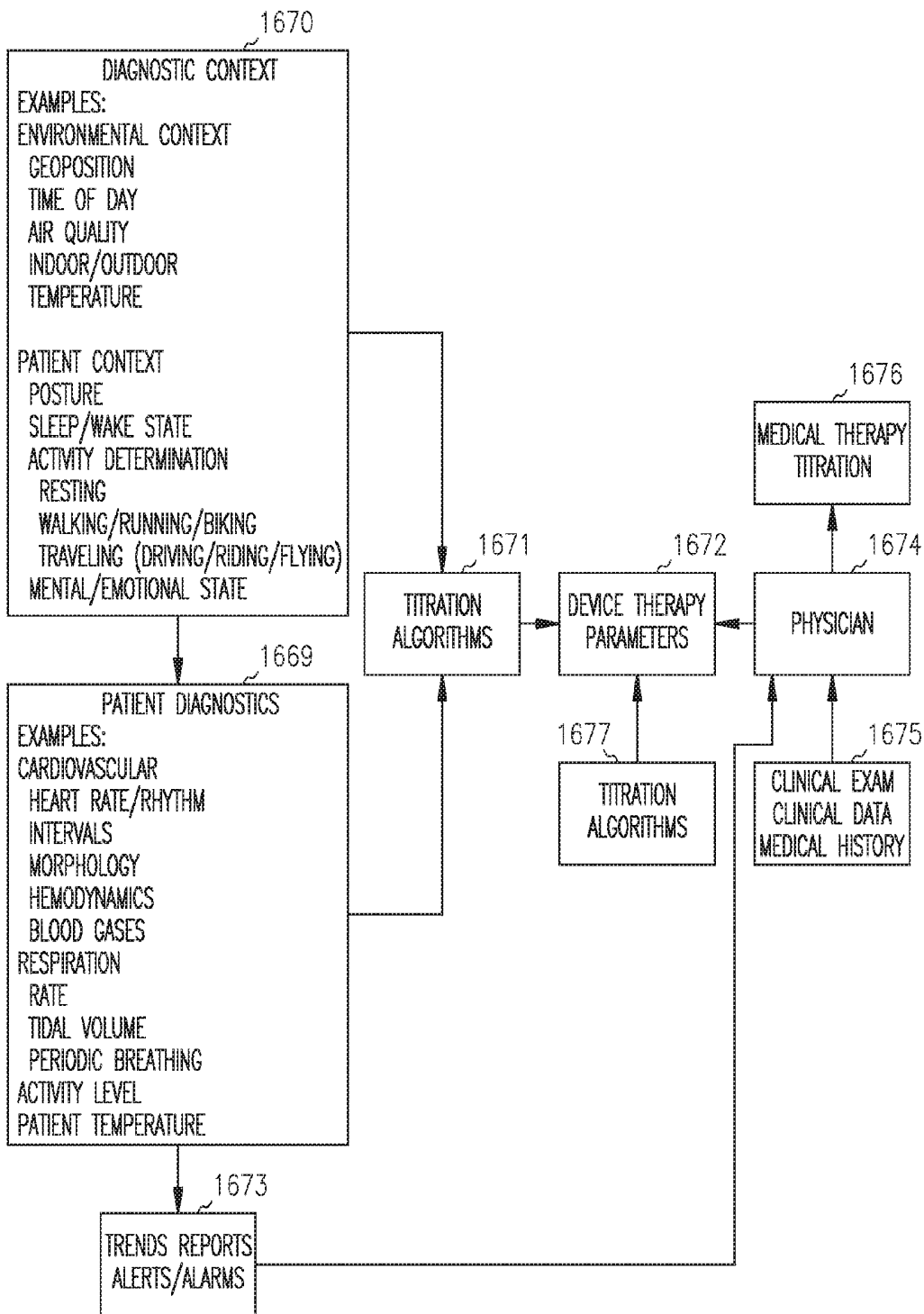

FIG. 16

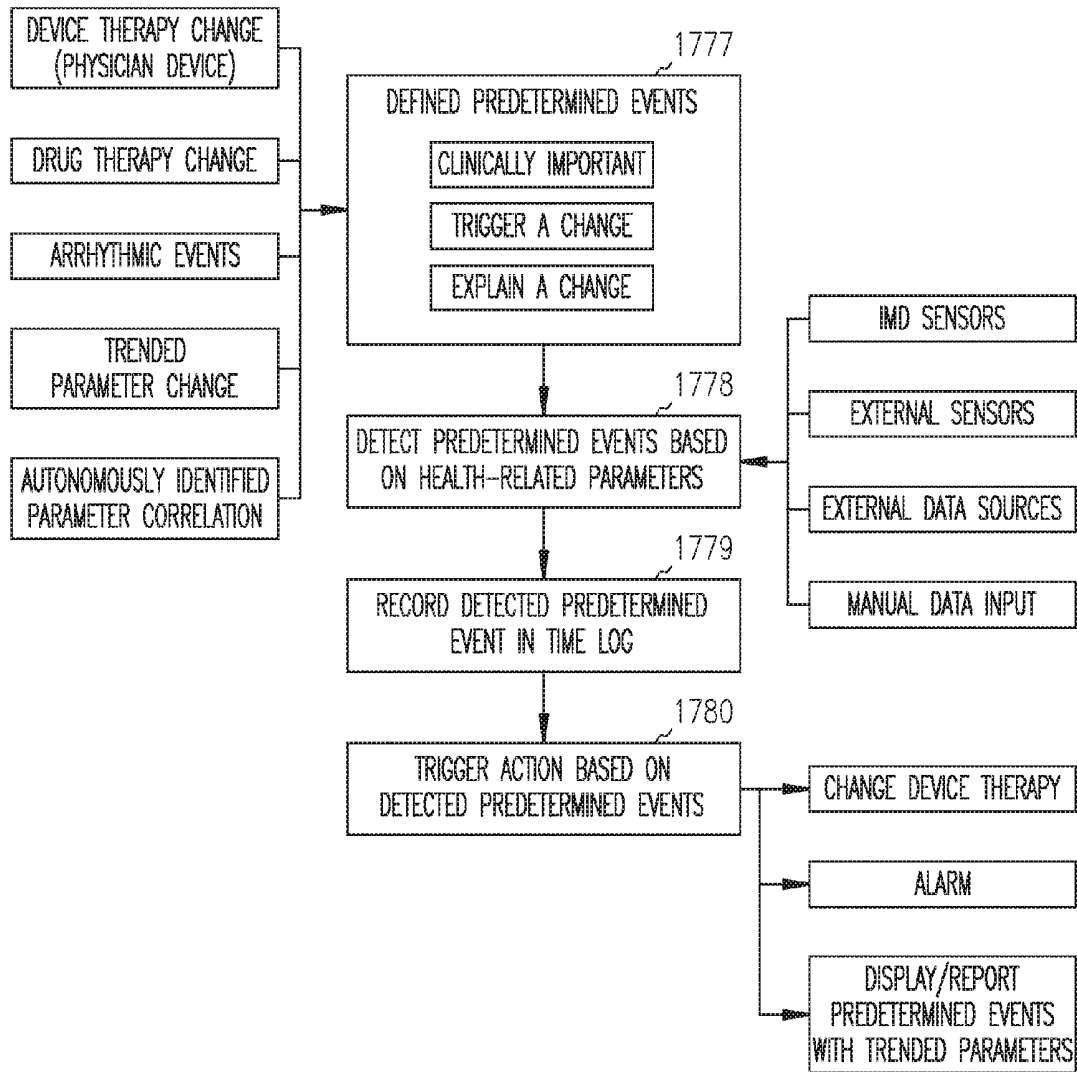

FIG. 17

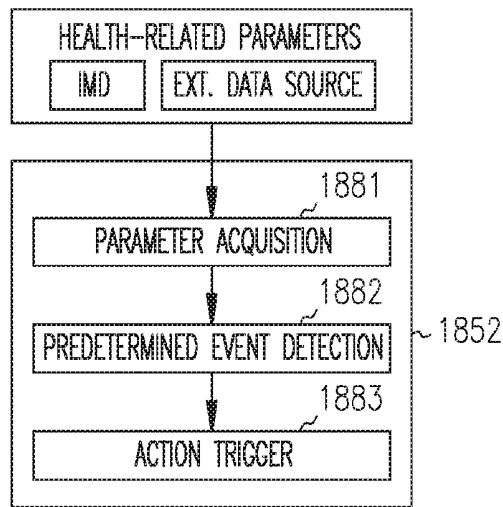

FIG. 18

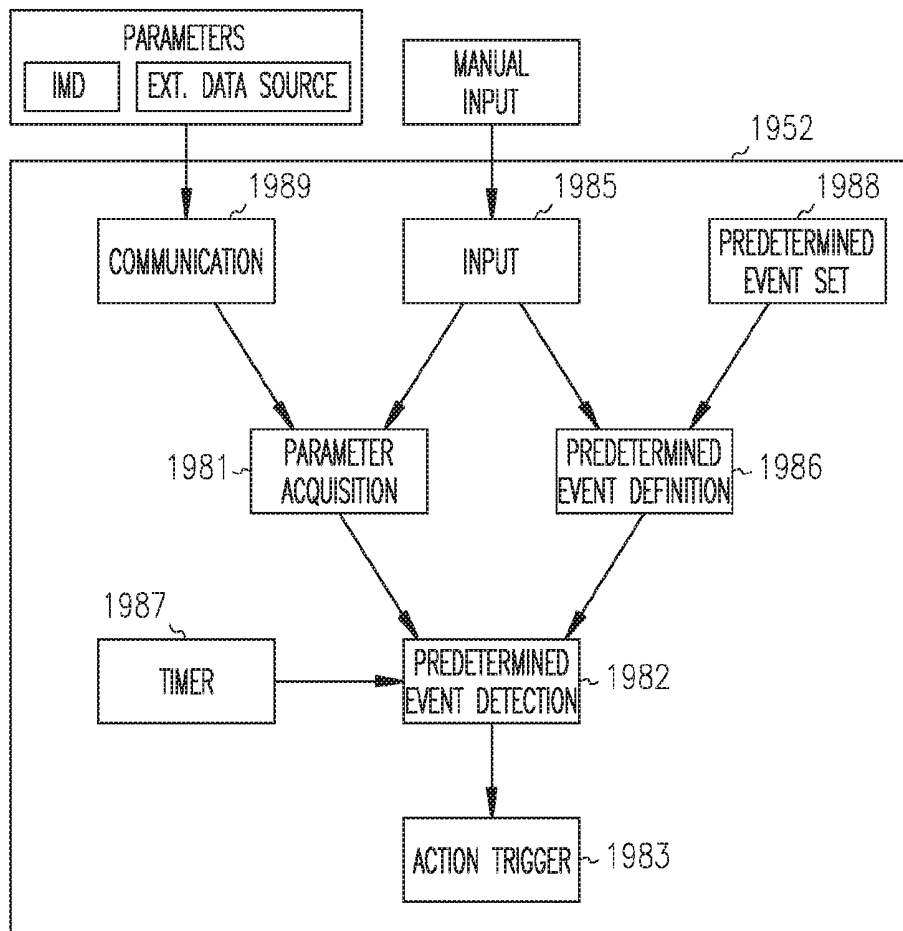

FIG. 19

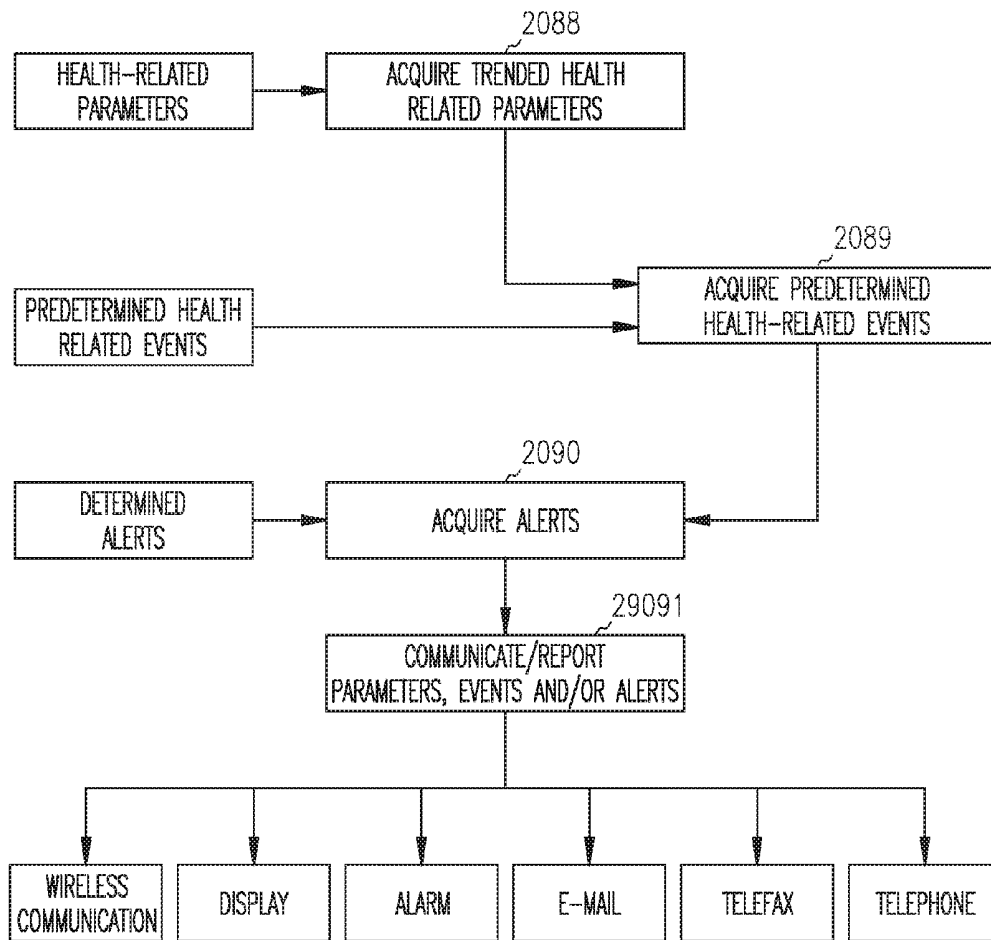

FIG. 20

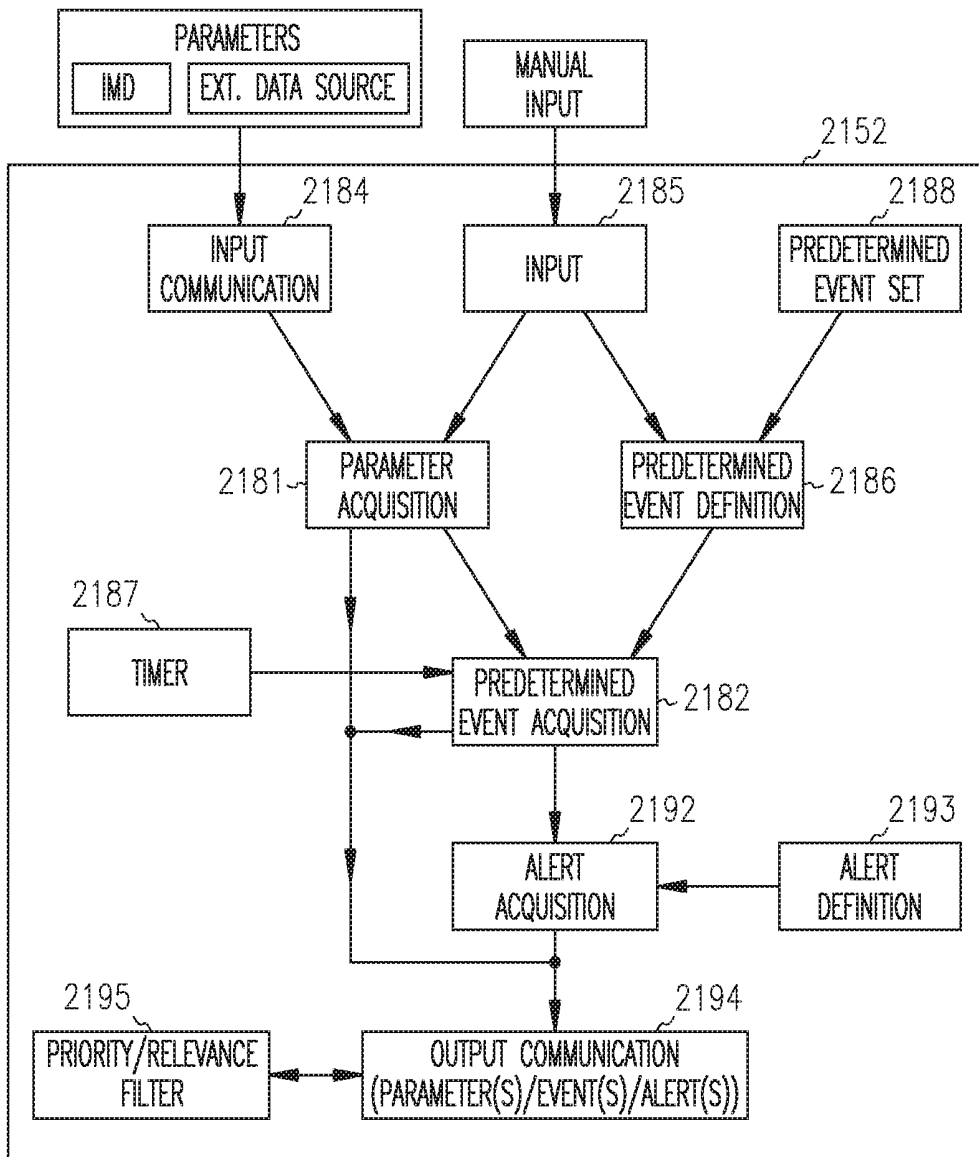

FIG. 21

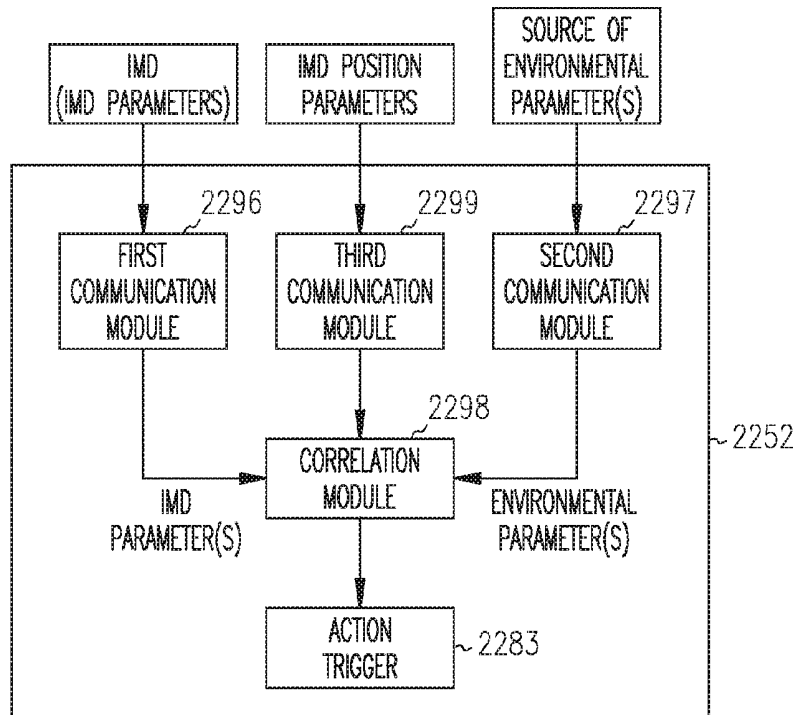

FIG. 22

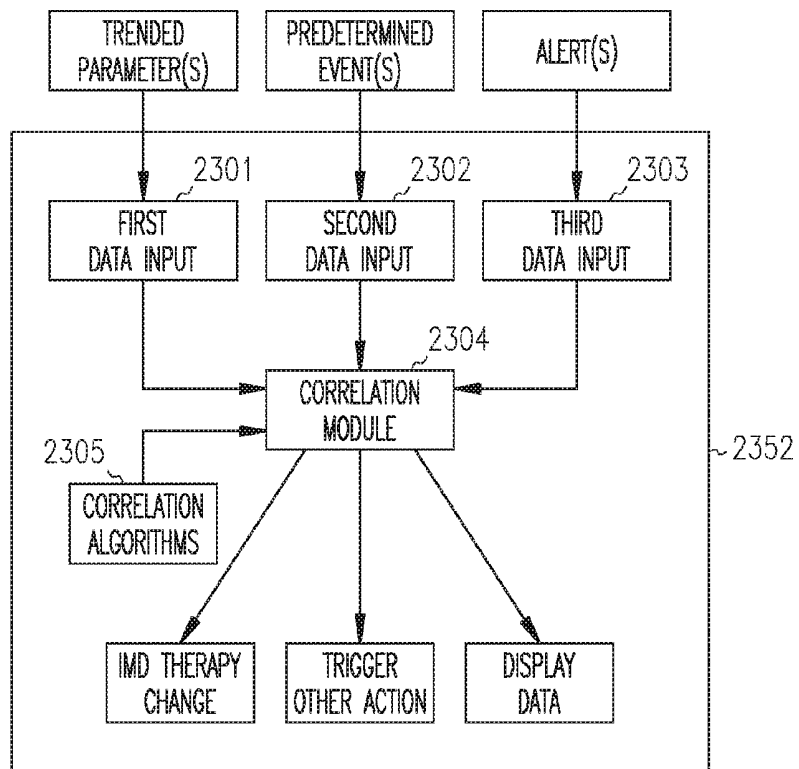

FIG. 23

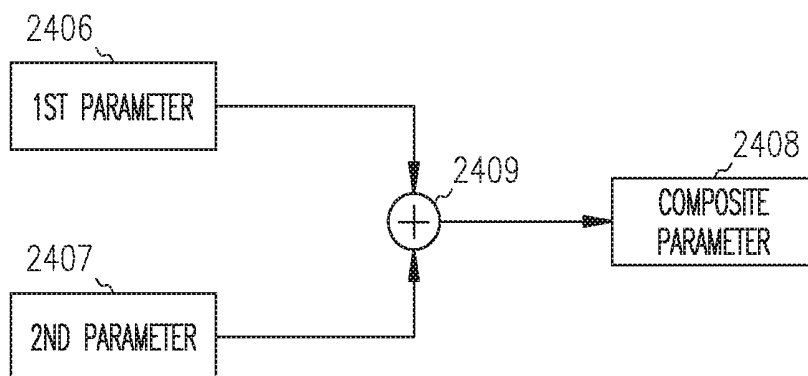

FIG. 24

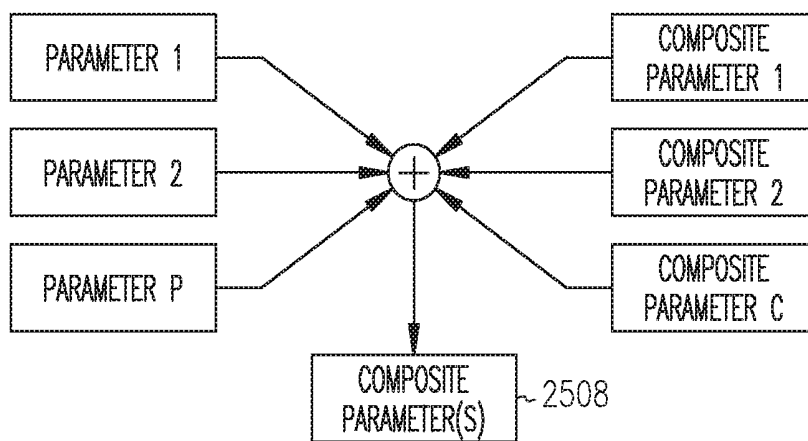

FIG. 25

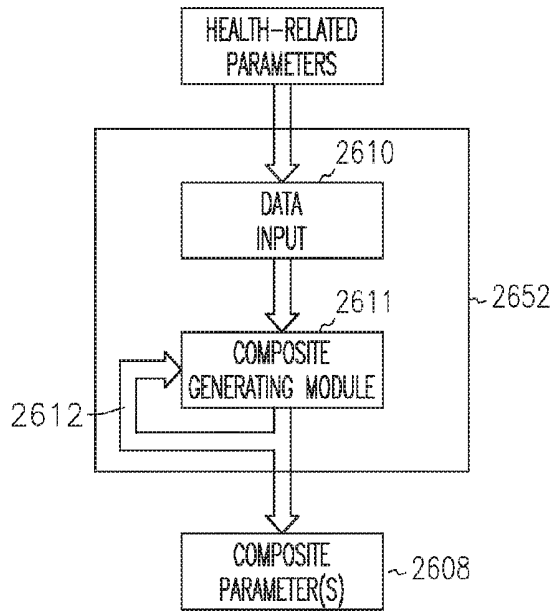

FIG. 26

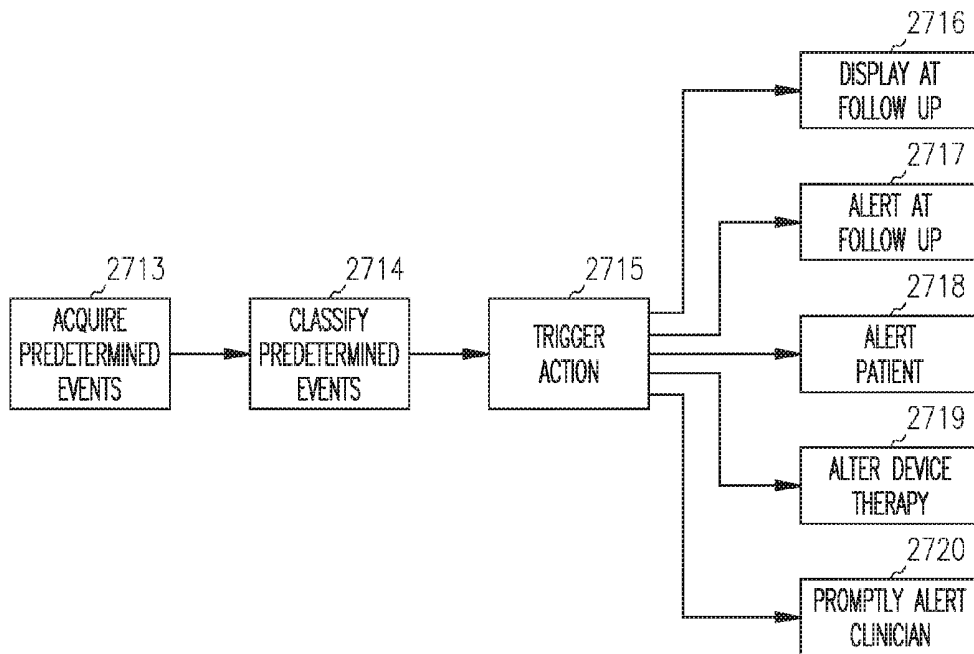

FIG. 27

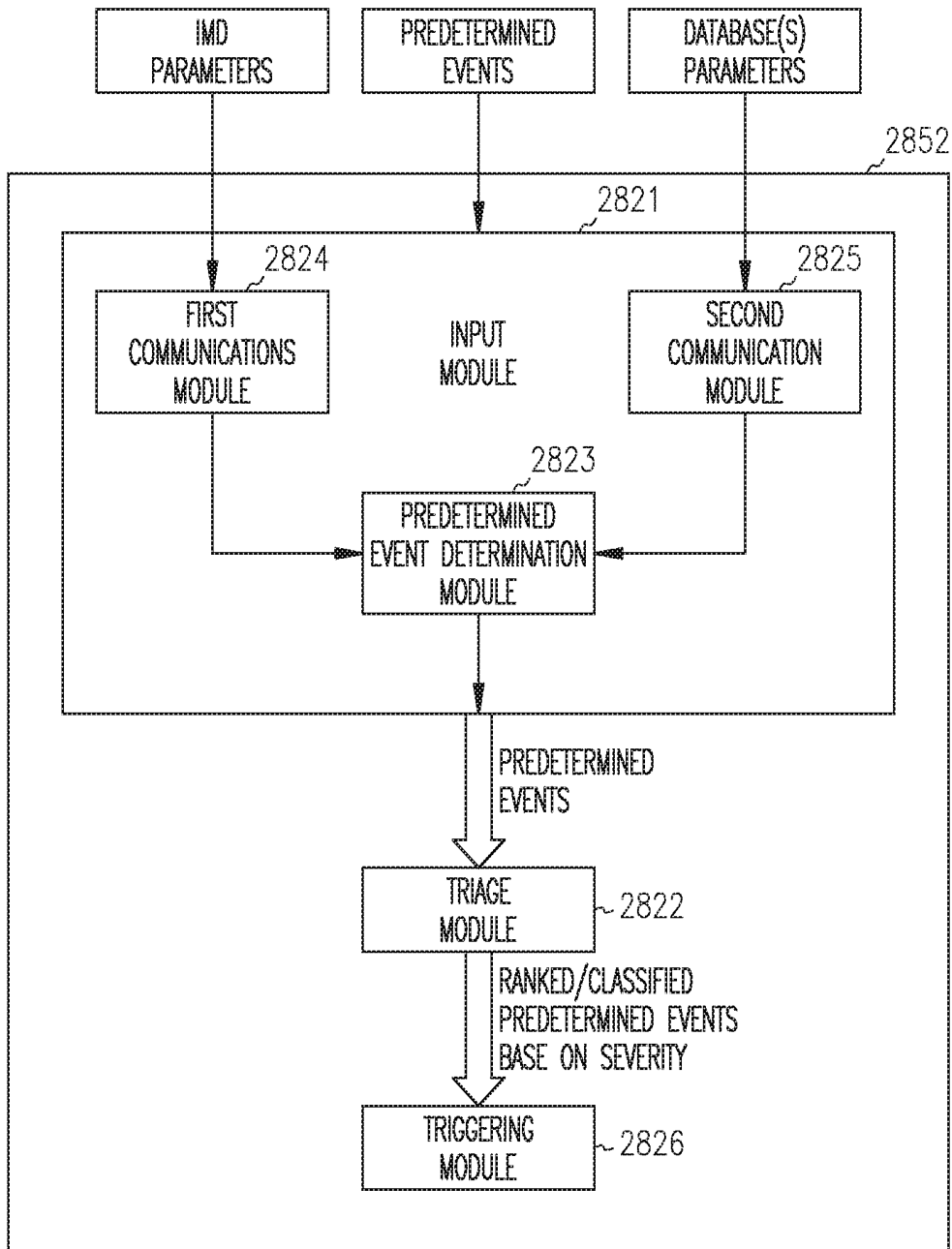

FIG. 28

ADVANCED PATIENT MANAGEMENT WITH ENVIRONMENTAL DATA

CLAIM OF PRIORITY

This application is a continuation of U.S. application Ser. No. 13/185,121, filed Jul. 18, 2011, which is a continuation of U.S. application Ser. No. 12/350,875, filed Jan. 8, 2009, now issued as U.S. Pat. No. 7,983,745, which is a continuation of U.S. application Ser. No. 10/323,590, filed Dec. 18, 2002, now abandoned, which are hereby incorporated by reference in their entirety.

CROSS REFERENCE TO RELATED APPLICATIONS

This application is related to the following commonly assigned U.S. patent applications which are herein incorporated by reference in their entirety: "Method and Apparatus for Establishing Context Among Events and Optimizing Implanted Medical Device Performance," Ser. No. 10/093,353, filed on Mar. 6, 2002, now U.S. Pat. No. 7,043,305; "Advanced Patient Management For Acquiring, Trending and Displaying Health-Related Parameters," Ser. No. 10/323,859, filed on Dec. 18, 2002, published as US 2004/0122486 A1; "Advanced Patient Management For Defining, Identifying and Using Predetermined Health-Related Events," Ser. No. 10/323,604, filed on Dec. 18, 2002, published as US 2004/0122484 A1, now U.S. Pat. No. 8,391,989; "Advanced Patient Management For Reporting Multiple Health-Related Parameters," Ser. No. 10/323,606, filed on Dec. 18, 2002, now U.S. Pat. No. 7,983,759; "Advanced Patient Management For Identifying, Displaying And Assisting With Correlating Health-Related Data," Ser. No. 10/323,713, filed on Dec. 18, 2002, now U.S. Pat. No. 7,468,032; "Advanced Patient Management With Composite Parameter Indices," Ser. No. 10/323,860, filed on Dec. 18, 2002, published as US 2004/0122487 A1, abandoned; "Advanced Patient Management For Triaging Health-Related Data," Ser. No. 10/323,616, filed on Dec. 18, 2002, published as US 2004/0122296 A1, abandoned; and "Advanced Patient Management For Triaging Health-Related Data Using Color Codes," Ser. No. 10/323,607, filed on Dec. 18, 2002, published as US 2004/0122295 A1, now U.S. Pat. No. 8,043,213.

TECHNICAL FIELD

This application relates generally to medical devices and, more particularly, to advanced patient management using environmental parameters.

BACKGROUND

An Implantable Medical Device (IMD) is a medical device designed to be chronically implanted in a human or other organism. Some IMDs include sensors to monitor a patient's condition, and some IMDs have been used to treat a patient. Some examples of IMDs include implantable cardiac rhythm management (CRM) devices such as cardiac pacemakers and implantable cardioverter/defibrillators (ICDs). Other examples of IMDs include a number of monitors or sensors, stimulators and delivery systems for both cardiac-related applications and non-cardiac-related applications.

The sensed data from the IMD is capable of being wirelessly communicated to an external device, and the

external device is capable of wirelessly programming the IMD. For example, data from an implantable CRM is capable of being wirelessly communicated to a programmer device. Additionally, the programmer is capable of wirelessly communicating with the implantable CRM to program the CRM to perform a desired device function.

Due to the potentially large amount of data capable of being sensed by one or more IMDs, it is desired to appropriately process the large amount of sensed data to provide meaningful information. The sensed data alone may not be an accurate indication of the overall health of the patient because other factors can significantly influence the sensed data. Thus, it has been proposed to use patient data from other sources. However, this patient data can compound the problem of providing meaningful data, and still may not provide an accurate indication of the overall health of the patient.

SUMMARY

The above mentioned problems are addressed by the present subject matter and will be understood by reading and studying the following specification. The present subject matter provides for acquiring health-related parameters from a variety of sources including data provided by an implanted medical device (IMD) and from sources of environmental data.

One aspect is an advanced patient management system. In various embodiments, the system includes at least one implantable medical device (IMD) to acquire at least one IMD parameter indicative of patient wellness, means to acquire at least one environmental parameter from at least one external source, and means to correlate the at least one parameter indicative of patient wellness and the at least one environmental parameter to assist with patient health care decisions.

One aspect is a device for monitoring a patient's health condition. In various embodiments, the device includes a first data input, a second data input, and a correlation module. In operation, the first data input acquires at least one implantable medical device (IMD) parameter indicative of patient wellness from at least one IMD, the second data input communicates with a source of at least one environmental parameter that is external to the at least one IMD to acquire the at least one environmental parameter, and the correlation module communicates with the first communication module and the second communication module and correlates the at least one IMD parameter and the at least one environmental parameter.

One aspect is a programmable device having machine executable instructions for performing a method to assist with patient healthcare decisions. In various embodiments, at least one health-related parameter is acquired from at least one implantable medical device (IMD). At least one environmental parameter is acquired from a source external to the at least one IMD. The at least one health-related parameter is synthesized with the at least one environmental parameter.

These and other aspects, embodiments, advantages, and features will become apparent from the following description and the referenced drawings.

BRIEF DESCRIPTION OF THE DRAWINGS

FIG. 1 illustrates an advanced patient management (APM) system according to various embodiments of the present subject matter.

FIG. 2 illustrates an advanced patient management (APM) system according to various embodiments of the present subject matter.

FIG. 3 illustrates an advanced patient management (APM) system having direct communication links according to various embodiments of the present subject matter.

FIG. 4 illustrates an advanced patient management (APM) system having network communication links according to various embodiments of the present subject matter.

FIG. 5 illustrates an advanced patient management (APM) system having network communication links according to various embodiments of the present subject matter.

FIG. 6 illustrates a perspective view of an advanced patient management (APM) system that includes an IMD and a portable device such as a PDA.

FIG. 7 illustrates a perspective view of an advanced patient management (APM) system that includes an IMD, a portable device such as a PDA, and another wellness monitoring device, such as a programmer for the IMD, networked to the PDA.

FIG. 8 illustrates a perspective view of an advanced patient management (APM) system that includes an IMD, a portable device such as a PDA, and another wellness monitoring device, such as a programmer for the IMD, directly connected to the PDA.

FIG. 9 illustrates a block diagram of an IMD according to various embodiments of the present subject matter.

FIG. 10 illustrates a block diagram of a wellness monitoring device, such as a portable device, according to various embodiments of the present subject matter.

FIG. 11 illustrates various embodiments of a wellness monitoring device (WMD) in the form of a general-purpose computing device.

FIG. 12 illustrates a block diagram of an advanced patient management system for acquiring, trending and displaying multiple health-related parameters according to various embodiments of the present subject matter.

FIG. 13 illustrates a block diagram of a wellness trending display generally illustrating parameter trends available for display according to various embodiments of the present subject matter.

FIG. 14 illustrates a block diagram of a wellness trending display illustrating an arrangement for selecting and displaying parameter trends according to various embodiments of the present subject matter.

FIG. 15 illustrates an example of a wellness trending display.

FIG. 16 illustrates a block diagram according to various aspects of the present subject matter in which a diagnostic context is provided to assist with interpreting the health condition of the patient, and to appropriately adjust the device and/or medical therapy, accordingly.

FIG. 17 illustrates a method for managing a patient's health by defining, detecting and using predetermined health-related events, according to various embodiments of the present subject matter.

FIG. 18 illustrates a device (such as a WMD or IMD) for monitoring a patient's health condition that is capable of detecting predetermined health-related events, according to various embodiments of the present subject matter.

FIG. 19 illustrates a wellness monitoring device (WMD) for monitoring a patient's health condition that is capable of detecting predetermined health-related events, according to various embodiments of the present subject matter.

FIG. 20 illustrates a method for reporting multiple parameters related to a health condition of a patient, according to various embodiments of the present subject matter.

FIG. 21 illustrates a device (such as a WMD or IMD) for monitoring a patient's health condition that is capable of prioritizing communication of health-related parameters, according to various embodiments of the present subject matter.

FIG. 22 illustrates a device (such as a WMD or IMD) for monitoring a patient's health condition that is capable of synthesizing environmental parameters with IMD parameters, according to various embodiments of the present subject matter.

FIG. 23 illustrates a device (such as a WMD or IMD) for monitoring a patient's health condition that is capable of correlating trended parameters, predetermined events, and alerts, according to various embodiments of the present subject matter.

FIG. 24 illustrates a method to generate composite parameters for use in managing a patient's health, according to various embodiments of the present subject matter.

FIG. 25 illustrates a method to generate composite parameters for use in managing a patient's health, according to various embodiments of the present subject matter.

FIG. 26 illustrates a device (such as a WMD or IMD) for monitoring a patient's health condition that is capable of generating composite parameters, according to various embodiments of the present invention.

FIG. 27 illustrates a method to triage predetermined events for use in managing a patient's health, according to various embodiments of the present subject matter.

FIG. 28 illustrates a device (such as a WMD or IMD) for monitoring a patient's health condition that is capable of classifying a number of predetermined events according to severity, and performing a system action based on the classification, according to various embodiments of the present subject matter.

DETAILED DESCRIPTION OF THE INVENTION

The following detailed description refers to the accompanying drawings which show, by way of illustration, specific aspects and embodiments in which the present subject matter may be practiced. These embodiments are described in sufficient detail to enable those skilled in the art to practice the present subject matter. Other embodiments may be utilized and structural, logical, and electrical changes may be made without departing from the scope of the present subject matter. The various embodiments disclosed herein are not necessarily mutually exclusive, as some disclosed embodiments can be combined with one or more other disclosed embodiments to form new embodiments. The following detailed description is, therefore, not to be taken in a limiting sense, and the scope of the present subject matter is defined only by the appended claims, along with the full scope of equivalents to which such claims are entitled.

The present subject matter provides a system to assist with monitoring the overall health of patients, and thus to assess and treat health conditions, using environmental parameters. In various embodiments, a clinician such as a physician monitors the patient's health. In various embodiments, the system includes an implantable medical device (IMD) which is capable of sensing various health-related parameters (also referred to herein as internal health-related parameters) indicative of a health condition. The IMD includes one or more IMD sensors to sense one or more desired internal health-related parameters. In various embodiments, the IMD is capable of providing therapy to

treat the health condition. In various embodiments, the system includes an external health data source that includes other health-related parameters (also referred to herein as external health-related parameters). The external health-related parameters (such as environmental parameters) can influence the sensed internal health-related parameters. Thus, a combination of internal and external health-related parameters can provide a more accurate view of the patient's health.

In various embodiments, the system includes a user input to collect health-related information that is contributed voluntarily by a user (such as a patient, clinician or other user). This user-volunteered information is an example of external human-resource parameters and is able to be more subjective in nature (compared to the internal health-related parameters determined by sensors or other external health-related parameters such as databases and external sensors), and thus is useful to identify other information that can influence the other health-related parameters. The present subject matter acquires internal and/or external health-related parameters from one or more of these sources, trends the parameters, and displays the trended parameters in a useful manner on a wellness monitoring device to assist with accurately assessing and treating a patient's health condition. As such, the present subject matter is capable of providing a diagnostic context used to interpret the health condition of the patient, and to appropriately adjust the device and/or medical therapy, accordingly.

A large number of health-related parameters are capable of being acquired, trended and displayed according to various embodiments of the present subject matter. For example, a non-exhaustive list of health-related parameters includes heart rate/rhythm including ventricular tachycardia and fibrillation, conduction intervals, ectopic density, atrial fibrillation (AF)/atrial tachycardia (AT) percent, heart rate variability (HRV), activity, lead position, concomitant conditions, temperature, blood pressure, respiration rate/rhythm, pulmonary/peripheral edema, posture, blood gases, stroke volume contractility, filling time, heart sounds, weight, ischemia, cardiac output, after load, medications, device indications, and electromyogram. Other examples of health-related parameters are provided throughout this disclosure.

These health-related parameters are capable of being acquired from a number of data sources. For example, a non-exhaustive list of data sources include IMDs, external device sensors, medication usage monitors, databases, and user inputs by a clinician and/or patient. An IMD, for example, is capable of providing health-related parameters for rhythms, conduction delays, respiration, activity, heart sounds, posture, and the like. External device measurements, for example, are capable of providing health-related parameters for weight, blood pressure, echo pulse oximetry, peripheral edema, and the like. Other examples of IMD health-related parameters and external health-related parameters are provided throughout this disclosure. A physician, for example, is capable of providing health-related parameters for lead positions, indications(s), medications, concomitant conditions, and the like. A medical database, for example, is capable of providing health-related parameters from external device measurements and physician input for medical tests and a large number and a large variety of other parameters. A patient, for example, is capable of providing health-related parameters for diet, medication usage, symptoms, blood pressure, and the like. As technology continues to improve, more and more health-related parameters will be

automatically acquired using, for example, an IMD rather than using an external interactive system.

In various embodiments of the present subject matter, the APM system performs various methods related to managing a patient's health. The APM system includes a number of programmable devices with a machine-readable medium having machine-executable instructions. The programmable device(s) perform the machine-executable instructions to perform the method. In various embodiments, the programmable device includes a processor to perform the machine-executable instructions. In various embodiments, the machine-executable instructions are provided on one or more machine-readable mediums (or media).

FIG. 1 illustrates an advanced patient management system according to various embodiments of the present subject matter. Various embodiments of the system **100** include less than all of the components shown in FIG. 1, and various embodiments of the system **100** include other components than those shown in FIG. 1.

A patient **101** is illustrated with an implantable medical device (IMD) **102**. Generally, the IMD includes one or more IMDs that provide internal therapy and/or acquire or sense internal data parameters. In various embodiments, the IMD is a CRM device that provides cardiac rhythm management pulsing and also senses one or more physiological parameters of a heart. Other IMDs that sense parameters and/or provide therapy, including various electrical and drug therapy, are within the scope of the present subject matter.

In various embodiments, at least one IMD **102** provides internal data such as heart rhythm, breathing, and activity. Other types of data derived from IMDs are also contemplated. For example, in one embodiment, a respiration sensor is implanted into patient and communicates with portable device. Data received from such IMDs may be perceived as involuntary, or passive, data since the patient has no control over the process of collecting and transmitting the data from such sources. In various embodiments, IMD-provided data includes parameters sensed by the IMD and/or parameters provided by interrogating the IMD to obtain device performance status.

The illustrated system also includes one or more external data source(s) **103** that provide health-related parameters. The external health-related parameters supplement the internal parameters and/or provide a diagnostic context to the internal health-related parameters. Examples of external source(s) of health data include: external sensing devices such as body temperature thermometers, blood pressure monitors, and the like; room temperature thermometers, light sensors and the like; databases such as patient history databases that are found hospitals or clinics and that may include information such as medical test results and family history; a web server database (a database accessible through a global communication network—e.g. Internet) that may include information regarding environment, medication interaction, and the like; databases and/or user inputs regarding mental/emotional and diet parameter types; and other external data sources capable of providing health-related parameters. One definition of the term mental is something that is of or relates to the mind. One definition of the term emotional is a strong feeling, aroused mental state, or intense state of drive or unrest, which may be directed toward a definite object and is evidenced in both behavior and in psychologic changes, with accompanying autonomic nervous system manifestations.

The illustrated system also includes a user input **104** through which a user is able to input additional health-related parameters for use by a wellness monitoring device

(WMD) **105**. In various embodiments, the user input **104** includes a touch screen on a PDA or other device, a keyboard and mouse on a computer, and the like. In various embodiments, a patient is able to input additional health-related parameters for use by the wellness monitoring device. In various embodiments, a clinician is able to input additional health-related parameters for use by the WMD.

The WMD **105** is illustrated by dotted line, and includes one or more devices. In various embodiments, the at least one IMD **102** communicates wirelessly with at least one WMD **105**, as shown by communication link **106**. In various embodiments that include multiple WMDs, the WMDs are able to communicate with each other, as shown via communication link **107**. In various embodiments, the WMD(s) includes portable devices **108** that are external to the body of patient such as a PDA, (variously referred to as a personal digital, or data, assistant), a portable telephone (including a cellular telephone or a cordless telephone), a pager (one way or two way), a handheld, palm-top, laptop, portable or notebook computer, or other such battery operated portable communication device. In various embodiments, the WMD(s) includes programmers. In various embodiments, the WMD(s) includes various non-portable devices such as larger computers or computer enterprise systems.

In various embodiments of the present subject matter, the WMD **105** (which includes one or more devices) includes a display on which parameter trends are capable of being displayed. In various embodiments, the portable device **108** includes a touch-sensitive display screen for displaying information to a user or patient. Depending on the application executing on the portable device **108**, the display screen may provide prompts, messages, questions, or other data designed to elicit an input from patient. Examples of such prompts are provided in the patent application entitled "Method and Apparatus for Establishing Context Among Events and Optimizing Implanted Medical Device Performance," Ser. No. 10/093,353, filed on Mar. 6, 2002, now U.S. Pat. No. 7,043,305, which has previously been incorporated by reference in its entirety. Data received from such interactive prompts may be perceived as voluntary, or active, data since the cooperation and active input of the patient is part of the data collection process. In various embodiments, the user input data may be received from a user based on a prompt provided to the user, on an ad hoc basis as determined by the user, or as determined by a processor. The user may enter data using a menu based system, a graphical user interface (GUI), textual data or numerical data.

The WMD provides analysis of internal and external (both voluntary and involuntary) parameters. In various embodiments, the WMD includes computer and programming that conducts data analysis suitable for use in managing patient health and medical care.

FIG. 2 illustrates an advanced patient management (APM) system according to various embodiments of the present subject matter. Various embodiments of the system **200** include all of the components shown in FIG. 2, various embodiments of the system **200** include less than all of the components shown in FIG. 2, and various embodiments of the system **200** include other components than those shown in FIG. 2.

In the figure, the system **200** is shown to include an IMD **202**. In various embodiments, the IMD includes an implantable cardiac device (ICD), cardiac rhythm management (CRM) device, pulse generator, or other implanted medical device that provides therapy to a patient or an organ of a patient, and/or that provides data derived from measure-

ments internal to a patient. In various embodiments, the IMD includes a device to provide drug therapy.

The illustrated system **200** includes at least one WMD **205** that includes at least one display for displaying trended parameters. In the illustrated system, the at least one WMD includes a portable device **208** (such as a PDA) and a programmer **209**. The IMD **202** is shown coupled to the portable device **208** by communication link **210**. The portable device is further coupled to the programmer by communication link **207**. Various embodiments of the present subject matter do not include the portable device **208**. In these embodiments, the IMD **202** is able to be coupled directly to the programmer **209** by a communication link (not shown).

At least one external data source **203** (such as web server(s), database(s), and sensor(s)) is coupled to the WMD(s) via at least one communication link. The external data source **203** provides external (with respect to the IMD in the patient) health-related parameters that supplement and/or provide context for the IMD parameters. In the illustrated system, a communication link **211** exists between the portable device **208** and the external data source **203**, and a communication link **212** exists between the programmer **209** and the external data source **203**. It is noted that various applications may not require both communication links **211** and **212**. In the illustration, the system **200** includes at least one user input **204** to the at least one WMD **205**. For example, a patient is able to provide health-care information using the portable device **208**, and a health care provider is capable of providing health-care information using the programmer **209**.

In various embodiments, the IMD also includes circuitry and programming adapted to monitor the condition and performance of the pulse generator or other IMD. For example, in various embodiments, the IMD provides data concerning the remaining battery condition for a power supply coupled to the IMD. Such data may include information regarding remaining battery capacity or life, battery internal resistance or other measurable parameters. In various embodiments, the data includes information regarding the electrical therapy provided by the IMD. For example, in various embodiments, such data includes lead impedance, sense voltage levels, therapy history, and device therapy mode settings and parameter values. In various embodiments, the IMD provides data regarding dosage, timing and other functions regarding the delivery of a drug therapy or other therapy. For example, in various embodiments, the IMD monitors blood sugar levels and the amount and timing of insulin delivered to the patient.

In various embodiments, the IMD includes a program executing on an internal processor that controls the operation of the IMD. The program instructions reside in a memory accessible to the internal processor. By changing the program, or memory contents, the present system allows the operating program of the IMD to be dynamically tailored to a particular patient or condition. In various embodiments, the operating system, or memory contents of the IMD is changed using wireless communication.

In various embodiments, the IMD includes a wireless transceiver. The transceiver operates using radio frequency transmissions, electromagnetic transmissions, magnetic coupling, inductive coupling, optical coupling, or other means of communicating without need of a wire connection between the IMD and another transceiver.

In various embodiments, the IMD performs a data acquisition function. In various embodiments, the IMD is adapted to monitor a fluid pressure, such as blood or urine. In various

embodiments, the detector is adapted to monitor respiration, stress level, or other measurable biometric parameter. In various embodiments, monitoring includes determining an absolute or relative value for a particular biometric parameter. In various embodiments, internal memory within the IMD stores a comparison value which may then be compared with a measured value thereby determining the performance of the IMD or the health of the patient.

In various embodiments, the communication link includes a wireless communication link between the IMD and portable device. The communication link allows communication in one or two directions.

In various embodiments, data from the IMD is communicated to portable device with no data transmitted from portable device to the IMD. In this manner, portable device functions as a data storage facility for the IMD. In various embodiments, data stored in portable device is accessed by a treating physician and used for diagnosis, therapy or other purposes. Programming and controlling the operation of the IMD is performed using a programmer adapted to transmit commands, data or code to the IMD. In various embodiments, portable device executes programming to analyze and process the data received from the IMD. In various embodiments, communication link precludes transfer of data from portable device to the IMD or precludes transfer of data from the IMD to portable device. For example, it may be desirable in certain circumstances to prevent the portable device from executing programming to automatically adjust the performance or operation of the IMD independent of a programmer.

In various embodiments, data is communicated from portable device to the IMD with no data transmitted from the IMD to portable device. In this manner, portable device functions as an interface to communicate commands, data or code to the IMD. In various embodiments, data is communicated from the IMD to the portable or external device with no data transferred from the device to the IMD.

In various embodiments, data is communicated bidirectionally between the IMD and the portable device. In various embodiments, the communication link between the IMD and the portable device entails a single bidirectional communication channel or includes multiple unidirectional communication channels which, when viewed as a whole, provide bidirectional communication. In various embodiments, a unidirectional communication channel operates using a particular frequency or communication protocol. For example, the link may include a wireless radio frequency link compatible with a transmitter and receiver that uses frequency hopping, spread spectrum technology.

In various embodiments, internal memory within the IMD provides storage for data related to the IMD-provided therapy (such as CRM therapy provided to a heart). For example, the data can relate to the electrical, chemical or mechanical operation of the heart. In addition, the IMD includes memory for programming, comparison and other functions. In various embodiments, the contents of the memory regulates the operation of the IMD.

In various embodiments, the portable device **208** includes or otherwise is incorporated or in communication with a battery operated portable communicator having a processor, memory, and an output interface to communicate with a user and an input interface to receive user entered data. One suitable example of a portable communicator is that of a personal digital assistant (PDA). PDA devices typically include a display screen for presenting visual information to a user and a writing surface for entry of data using a stylus. Data can be entered using a keyboard coupled to the portable

communicator or by means of a wired or wireless communication link. Some portable communicator models also include an audio transducer, or sound generator, adapted to produce sounds that are audible by a user. In various embodiments, data from the IMD or the programmer is displayed on a display or screen of the portable device.

In various embodiments, the portable device **208** includes or otherwise is incorporated or in communication with a portable telephone (such as a cellular telephone or a cordless telephone), a pager (one way or two way), or a computer (such as a handheld, palm-top, laptop, or notebook computer) or other such battery operated, processor based, portable communication device.

In various embodiments, the portable device **208** includes data storage and includes programming and instructions to conduct data processing. In various embodiments, the data storage capacity of the portable device **208** augments the data storage capacity of the IMD **202**, thus enabling a clinician to access a greater amount of multi-related information regarding the medical condition of a user. For example, but not by way of limitation, the additional information may assist in discovering and understanding relationships among different events.

In various embodiments, a wireless receiver is coupled to a portable device for purposes of receiving data from the IMD **202** through communication link **210**. In various embodiments, a wireless transmitter is coupled to the portable device for purposes of transmitting data to the IMD. In various embodiments, a wireless transceiver is coupled to the portable device for purposes of both transmitting data to, and receiving data from, the IMD. In various embodiments, the portable device includes telemetry to facilitate wireless communications.

In various embodiments, circuitry or programming allows the portable device **208** to trigger an alarm under predetermined conditions. In various embodiments, for example, the portable device sounds an audible alarm or transmits an alarm signal if a biometric parameter exceeds a particular value or is outside a specified range of values. The alarm signal can be received by the programmer **209** or a designated physician.

Communication link **207** couples the portable device **208** with the programmer **209**. In various embodiments, communication link **207** includes a wired or wireless link that allows data communication between portable device and the programmer. In various embodiments, data is exchanged between portable device and the programmer by means of a removable storage media.

In various embodiments, the programmer **209** includes a processor based apparatus that executes programming to communicate with the IMD **202**, the portable device **208**, or both. A clinician (e.g. physician) can operate the programmer to communicate with the IMD using **202** portable device as a data interface. In particular, various embodiments provide that data from the IMD **202** can be retrieved by accessing the memory of portable device **208**. In various embodiments, the programmer **209** transmits data to the IMD **202** via the portable device **208**.

In various embodiments, at least one of the WMDs includes a display. FIG. 2 illustrates a system in which the portable device **208** includes a display and the programmer **209** includes a display. According to various embodiments of the present subject matter, health-related parameters are displayed on the display(s) of the wellness monitoring device(s). In various embodiments, these health-related parameters are acquired via an IMD and/or via an external source such as user input and/or external health data sources

such as databases and the like. According to various embodiments of the present subject matter, trended health-related parameters, predetermined events, alerts and/or other information provided in this disclosure are displayed on the wellness monitoring device(s).

FIG. 3 illustrates an advanced patient management (APM) system having direct communication links according to various embodiments of the present subject matter. According to various embodiments of the system 300, the communication links include wired links, wireless links or both wired and wireless links. Various embodiments include all of the components shown in FIG. 3, various embodiments include less than all of the components shown in FIG. 3, and various embodiments include other components than those shown in FIG. 3.

The illustrated system 300 includes at least one IMD 302, at least one external source of health data 303, and at least one WMD 305 with a display 313. The illustrated system includes a user input 304 to communicate with the WMD. The illustrated system includes a communication link 314 between the IMD(s) 302 and the external source(s) of health-related data 303, a communication link 315 between the external source(s) of health-related data 303 and the WMD(s) 305, and a communication link 316 between the IMD(s) 302 and the WMD(s) 305. It is noted that various embodiments include less than all of the communication links. For example, in various embodiments data from the external source(s) of health data is not communicated to IMD(s) through link 314, and in various embodiments data from the external source(s) of health data is communicated to the wellness monitor device(s) through the IMD(s) and links 314 and 316. Various embodiments implement various communication designs to achieve various data flow.

In various embodiments, the display 313 of the WMD(s) is used to display trended parameters, such as internal parameters from the IMD(s) and external parameters for the external source(s) of health-related data. Other information can be displayed, as is provided throughout the disclosure. Furthermore, a user is able to input additional external health-related information via user input. In various embodiments, the WMD(s) include a portable device such as a PDA, laptop computer, cell phone, and the like. In various embodiments, the WMD(s) include other external devices such as bedside monitors, desktop computers, IMD programmers, and the like.

FIG. 4 illustrates an advanced patient management (APM) system having network communication links according to various embodiments of the present subject matter. According to various embodiments, the communication links include wired links, wireless links or both wired and wireless links. Various embodiments include all of the components shown in FIG. 4, various embodiments include less than all of the components shown in FIG. 4, and various embodiments include other components than those shown in FIG. 4.

The illustrated system 400 includes at least one IMD 402, at least one external source of health data 403, at least one WMD 405 with a display 413, and at least one network infrastructure through which the other devices (also referred to within this discussion as network devices) are capable of communicating. The illustrated system includes a user input 404 to communicate with the WMD 405. In various embodiments, the WMD(s) includes a portable device such as a PDA, laptop computer, cell phone, and the like. In various embodiments, the wellness monitor device(s) include other external devices such as bedside monitors, desktop computers, IMD programmers, and the like. Examples of a network

communication link includes, but is not limited to, one or more of the following: cellular telephone coupled to a portable device via the Internet, a private area branch exchange (PABX, also known as a PBX); an intranet network; an ethernet connection or other remote communication means.

The illustrated system includes a communication link between the IMD(s) 402 and the external source(s) of health-related data 403 via the network 417, a communication link between the external source(s) of health-related data 403 and the WMD(s) 405 via the network 417, and a communication link between the IMD(s) and the WMD(s) 405 via the network 417. The illustrated system includes a network interface or adapter 418. The network adapter 418 wirelessly communicates with the IMD 402 via communication link 419, and communicates with network devices through network via communication link 420. Although not expressly, other network devices include a network interface.

Various embodiments include a direct communication link as illustrated in FIG. 3 and a network communication link as illustrated in FIG. 4. The display of the WMD(s) is used to display trended parameters, such as internal health-related parameters from the IMD(s) and external health-related parameters for the external source(s) of health-related data. Furthermore, a user is able to input additional external health-related information via user input.

FIG. 5 illustrates an advanced patient management (APM) system having network communication links according to various embodiments of the present subject matter. Various embodiments include all of the components shown in FIG. 5, various embodiments include less than all of the components shown in FIG. 5, and various embodiments include other components than those shown in FIG. 5.

The illustrated system 500 includes at least one IMD 502, at least one external source of health data 503, at least one WMD 505 with a display 513, and at least one network infrastructure 517 through which the other devices (also referred to within this discussion as network devices) are capable of communicating. The illustrated system 500 also includes direct communication connections 521 between the IMD(s) 502 and the external source(s) of the health data 503, and between the WMD(s) 505 and the IMD(s) 502. One of ordinary skill in the art will understand, upon reading and comprehending this disclosure, that various embodiments include some direct communication connections between some components and include some network communication connections between some components.

The illustrated external source(s) of health data 503 include at least one external sensing device 522 such as a body temperature or blood pressure monitor, at least one patient history database 523, at least one web server 524, and other external sources 525. Various embodiments of the present subject matter include one or more of the illustrated external sources of health data. The illustrated WMD(s) includes a programmer 509 with a display, a portable device 508 (such as a PDA or laptop computer) with a display, or other WMD(s) 526 with a display. Various embodiments of the present subject matter include one or more of the illustrated WMDs.

FIG. 6 illustrates a perspective view of an advanced patient management (APM) system that includes an IMD 602 and a portable device 608 such as a PDA. The illustrated portable device 608 includes a display screen 627, a plurality of user operable buttons 628, and an expansion port 629 which receives and is coupled to an expansion device 630 that is designed to communicate with the IMD 602. In

various embodiments, a specially designed portable device is employed with an integrated communication subsystem. A stylus **631** can be used to manually enter data using screen. Link **606** is illustrated as a bidirectional link and thus, data from IMD **602** is wirelessly telemetered to the portable device **608** through the expansion device **630**. In addition, data, or programming from the portable device **608** is wirelessly telemetered from the expansion device **630** to the IMD **602**.

According to various embodiments, the portable device (such as the illustrated PDA) generates a prompt at various times calling for a response in the form of a user input. A user may enter data using any of a variety of means. For example, a response may be entered using stylus, buttons, or an external keyboard. In one embodiment, portable device responds to voice commands received from a user. A prompt may be visually displayed using screen or audibly generated using an internal sound generator. Manually entered data received from a user, as well as data received from other inputs is stored using the portable device. The data stored in the portable device is available for processing, and to tailor the therapy.

In addition to data entry, the portable device **608** provides a user with limited control over the operation of an IMD **602** in various embodiments. In various embodiments, reasonable constraints on the authority to change the operation of IMD are established and implemented by a clinician.

FIG. 7 illustrates a perspective view of an advanced patient management (APM) system that includes an IMD **702**, a portable device **708** such as a PDA, and another WMD **732**, such as a programmer for the IMD, networked to the PDA. The illustrated portable device includes a wireless communication antenna **733**. In various embodiments, the portable device **708** is adapted for wireless access to Internet network using link **734**. In various embodiments, link **734** includes a radio frequency communication link. The programmer accesses the Internet via link **735**. In various embodiments, **735** link includes a dial-up modem connection, a cable modem connection, a DSL connection, an ISDN line, or other channel providing access to the Internet.

A user is able to compile contextual information regarding IMD **702**, as well as himself, using the portable device **708**. In various embodiments, a clinician using the programmer **732** is able to remotely access the data stored in the portable device **708** using link **735**, Internet and link **734**. In this manner, programmer **732** is able to wirelessly receive the data, process the data, and transmit data and code to change the future operation of the IMD **702**.

FIG. 8 illustrates a perspective view of an advanced patient management (APM) system that includes an IMD **802**, a portable device such as a PDA **808**, and another WMD **832**, such as a programmer for the IMD, directly connected to the PDA. The PDA is coupled to IMD by wireless link **836**, and is further coupled to programmer by link **837** (illustrated as a communication cable).

A clinician operating programmer **832** is able to exchange data or code with the PDA **808** using link **837**. Connector is a multi-conductor connector providing access to data of the PDA. It will be appreciated that link may couple the PDA to a local area network or other communication network. For example, the PDA may be connected to a public switched telephone network (PSTN) link, and thus, programmer may exchange data with portable communicator using a modem coupled to PSTN.

FIG. 9 illustrates a block diagram of an IMD according to various embodiments of the present subject matter. The

illustrated IMD **902** includes a processor **938**, memory **939**, an update module **940** and a transceiver **941**. In operation, the processor governs the operation of IMD and executes programming stored in memory. In addition to the executable program, memory also includes data storage regarding the patient and IMD. The update module operates in conjunction with processor, memory and transceiver to receive, install, and execute new instructions for execution by processor.

FIG. 10 illustrates a block diagram of a WMD, such as a portable device, a programmer and the like, according to various embodiments of the present subject matter. The illustrated WMD **1005** includes long term data storage **1042**, an input/output **1043**, a controller **1044**, an IMD transceiver **1045**, a communication interface **1046** and a display **1047**. The long term data storage augments the data storage capacity of the memory of the IMD. In various embodiments, the storage is of a greater capacity than that of memory, is physically larger in size, and is less expensive and more robust than medical grade implantable memory.

The input/output, the IMD transceiver and the communication interface, in conjunction with the controller enables receipt and transmission of data from the IMD as well as data from other sources such as other WMDs, databases and the like. The IMD transceiver provides a wireless communication link between the IMD and the portable device. The display is used to, among other things, display parameters that have been acquired and trended by the system according to the present subject matter.

FIG. 11 provides a brief, general description of a suitable computing environment in which the above embodiments may be implemented. The illustrated computing environment, or portions thereof, can be implemented in a WMD. Additionally, portions of the illustrated computing environment (such as the system memory and processor) can be implemented in IMDs.

Embodiments of the present subject matter can be described in the general context of computer-executable program modules containing instructions executed by a computing device. The term module includes hardware, firmware, software, and various combinations thereof to perform task(s) described in this disclosure, as is understood by one of ordinary skill in the art upon reading and comprehending this disclosure. Program modules include routines, programs, objects, components, data structures, etc. that perform particular tasks or implement particular abstract data types. Those skilled in the art will appreciate that the invention may be practiced with other computer-system configurations, including hand-held devices, multiprocessor systems, microprocessor-based programmable consumer electronics, network PCs, minicomputers, mainframe computers, and the like which have multimedia capabilities. The invention may also be practiced in distributed computing environments where tasks are performed by remote processing devices linked through a communications network. In a distributed computing environment, program modules may be located in both local and remote memory storage devices.

FIG. 11 illustrates various embodiments of a WMD in the form of a general-purpose computing device. One of ordinary skill in the art will understand, upon reading and comprehending this disclosure, how to implement the present subject matter using other WMDs and IMDs with some of the illustrated components or other components.

The illustrated computing device **1148** includes a processing unit **1149**, a system memory **1150**, and a system bus **1151** that couples the system memory and other system components to processing unit. The system bus may be any

of several types, including a memory bus or memory controller, a peripheral bus, and a local bus, and may use any of a variety of bus structures. The system memory includes read-only memory (ROM) and random-access memory (RAM). A basic input/output system (BIOS), stored in ROM, contains the basic routines that transfer information between components of personal computer. BIOS also contains start-up routines for the system. Various embodiments of the computing device further include a hard disk drive for reading from and writing to a hard disk (not shown), a magnetic disk drive for reading from and writing to a removable magnetic disk, and an optical disk drive for reading from and writing to a removable optical disk such as a CD-ROM or other optical medium. Hard disk drive, magnetic disk drive, and optical disk drive are connected to system bus by a hard-disk drive interface, a magnetic-disk drive interface, and an optical-drive interface, respectively. The drives and their associated computer-readable media provide nonvolatile storage of computer-readable instructions, data structures, program modules and other data for the computing device. Those skilled in the art will appreciate that other types of computer-readable media which can store data accessible by a computer may also be used.

Program modules can be stored on the hard disk, magnetic disk, optical disk, ROM and RAM. Program modules may include operating system, one or more application programs, other program modules, and program data. A user may enter commands and information into personal computer through input devices such as a keyboard and a pointing device. These and other input devices are often connected to the processing unit through a serial-port interface coupled to system bus; but they may be connected through other interfaces not shown in FIG. 11, such as a parallel port or a universal serial bus (USB). A monitor or other display device also connects to system bus via an interface such as a video adapter. In addition to the monitor, personal computers typically include other peripheral output devices (not shown) such as speakers and printers. In one embodiment, one or more speakers or other audio output transducers are driven by sound adapter connected to system bus.

In various embodiments the computing device operates in a networked environment using logical connections to one or more remote devices such as remote computer. Examples of remote computers include a personal computer (PC), a server, a router, a network PC, a peer device, or other common network node. In various embodiments, the remote computer includes many or all of the components described above in connection with the computing device; however, only a storage device is illustrated in FIG. 11 to simplify the disclosure. The logical connections depicted in FIG. 11 include local-area network (LAN) and a wide-area network (WAN). Such networking environments exist in offices, enterprise-wide computer networks, intranets and the Internet. The computing device connects to local network through a network interface or adapter in various embodiments, and to a WAN/Internet network through a modem or other means for establishing communications over network.

Various embodiments of the present subject matter are illustrated in FIGS. 12-27 and are discussed below. One of ordinary skill in the art will understand, upon reading and comprehending this disclosure, that these embodiments are not necessarily mutually exclusive as various embodiments can be combined or otherwise modified to create other embodiments. One of ordinary skill in the art also will understand, upon reading and comprehending this disclosure, that various elements shown and described with respect to one or more of FIGS. 1-11 are capable of being

combined with various elements shown and described with respect to one or more of FIGS. 12-27.

Acquisition, Trending and Displaying Health-Related Parameters

FIGS. 12-16 illustrate various embodiments of the present subject matter related to acquiring, trending and displaying health-related parameters. In various embodiments, an IMD acquires, trends and displays a variety of parameters pertinent to the health status of a patient.

FIG. 12 illustrates a block diagram of a device for acquiring, trending and displaying multiple health-related parameters according to various embodiments of the present subject matter. The device 1252 acquires available parameters from available sources. In various embodiments, the device 1252 includes a WMD such as a portable device, a programmer and the like. In various embodiments, the device 1252 includes an IMD. For example, potentially available sources include an IMD parameter collection 1253 (internal health-related parameters such as internal physiological measurements, applied therapy, device performance, and the like), an external parameter collection 1254 (external parameters such as external physiological and environmental measurements, databases, and the like), and a user input parameter collection 1255 (voluntary data). User inputs can be considered to be an external health-related parameter. However, for purposes of the description with respect to FIG. 12, external parameter collection and user input parameter collection are considered separately.

In various embodiments, the IMD parameter collection 1253 includes at least one of a physical parameter type, a physiological/pathological parameter type, a mental/emotional parameter type, a diet parameter type, an environmental parameter type, a symptom parameter type, and a medical compliance type. In various embodiments, the IMD is gathers information from an external device or sensor in order to gather certain parameter types. Furthermore, the IMD is capable of acquiring medication compliance by monitoring a measurable parameter correlated to compliance. For example, blood pressure is monitored to verify that a patient is compliant with hypertensive medications. The IMD is also capable of acquiring environmental data, such as barometric pressure using an implanted pressure sensor and such as relative temperature changes using an implanted temperature sensor near the surface of the skin.

One definition of mental is of or relating to the mind. One definition of emotional is relating to or marked by an emotion (a strong feeling, aroused mental state, or intense state of drive or unrest, which may be directed toward a definite object and is evidenced in both behavior and in psychologic changes, with accompanying autonomic nervous system manifestations). One definition of physiological is normal, as opposed to pathologic. One definition of pathological is diseased. Other definitions can be used consistently with respect to these terms.

In various embodiments, the external parameter collection 1254 includes one or more of a mental/emotional parameter type, an environmental parameter type and a diet parameter type. In various embodiments, the external parameter collection 1254 includes a physical parameter type, a physiological/pathological parameter type, a symptom parameter type, and/or a medication compliance parameter type. The external parameter collection can include any one or any combination of the above parameter types according to embodiments of the present subject matter.

In various embodiments, the user input parameter collection 1255 includes one or more of a mental/emotional parameter type, an environmental parameter type and a diet

parameter type. In various embodiments, the user input parameter collection 1255 includes a physical parameter type, a physiological/pathological parameter type, a symptom parameter type, and/or a medication compliance parameter type. The user input parameter collection can include any one or any combination of the above parameter types according to embodiments of the present subject matter.

Examples of a physical parameter type include, but are not limited to, parameters related to activity, posture, and sleep. Examples of a mental/emotional parameter type include, but are not limited to, parameters related to stress, excitement, anger, anxiety (such as may be detected via sighing), and depression. Examples of physiological/pathological parameter types include, but are not limited to, parameters related to blood pressure, respiration rate and patterns, and medical test results. Examples of environmental parameter types include, but are not limited to, parameters related to altitude, temperature, air quality, pollen count, and humidity. Examples of diet parameter types include, but are not limited to, parameters related to sodium intake, fluid intake and lipid intake. Examples of symptom parameter types include, but are not limited to, parameters related to pain, dyspnea and fatigue. In various embodiments, a symptom can be considered to be, for example, a patient-perceived condition based on frequency, severity and/or repetition. Examples of medication compliance parameter types include, but are not limited to, parameters related to drug administration such as drug type, dosage and time. Examples of drug type includes insulin, beta-blockers, diuretics and the like.

Health-related parameters are acquired from various sources. In various embodiments, a number of parameters are acquired from IMD, and from external sources such as external parameter collections (programmer, web servers, patient databases, external sensors, etc.) and user input parameter collections (answered questions, etc.). The parameter trends are displayed in a single display area of at least one of the WMDs.

In various embodiments, available parameters are acquired at module 1256. The acquired parameters are processed according to a procedure implemented in software. In various embodiments, the software automatically acquires those health-related parameters deemed to be useful based on a potential health condition. In various embodiments, the software instructions provide a procedure, when operated on by a processor, which automatically determines a potential health condition, and thus additional parameters to be acquired, from previously acquired parameters. Thus, the present subject matter is capable of automatically and intelligently acquiring additional parameters to confirm and/or dismiss an initial diagnosis.

In various embodiments, module 1257 includes software instructions that, when operated on by a processor, provide a procedure that automatically trends the acquired parameters. The trending procedure analyzes the parameters as a function of time or other measured parameter. In various embodiments, module 1258 allows a user to select parameter trends to be displayed in a single display area. Module 1259 is used to display representations in a single display area. In various embodiments in which device 1252 includes a WMD, module 1259 displays the representation on a display of the WMD. In various embodiments in which device 1259 includes an IMD, module 1259 transmits a signal for reception by a display device to display the representation on the display device.

In various embodiments, the acquired data and trends are analyzed to select an updated program or specify updated

operational parameters for the IMD. The updated program or operational parameters are capable of being transferred and implemented by IMD.

FIG. 13 illustrates a block diagram of a wellness trending display generally illustrating parameter trends available for display according to various embodiments of the present subject matter. In various embodiments of the display 1360, trends associated with at least one of a physical parameter type 1361, a physiological/pathological parameter type 1362, a mental/emotional parameter type 1363, an environmental parameter type 1364, a diet parameter type 1365, a symptom parameter type 1366 and a medication compliance parameter type 1367 (and various combinations of a physical parameter type, a physiological/pathological parameter type, a mental/emotional parameter type, an environmental parameter type, a diet parameter type, a symptom parameter type and a medication compliance parameter type) are available to be displayed in a single wellness trending display area 1360.

In various embodiments, parameters available to be displayed that are associated with a physical parameter type include, but are not limited to, parameters related to activity, posture, and sleep. In various embodiments, parameters available to be displayed that are associated with a mental/emotional parameter type include, but are not limited to, parameters related to stress, anxiety (such as may be detected via sighing), excitement, anger and depression. In various embodiments, parameters available to be displayed that are associated with a physiological/pathological parameter type include, but are not limited to, parameters related to blood pressure, respiration rate and patterns, and medical test results. In various embodiments, parameters available to be displayed that are associated with an environmental parameter type include, but are not limited to, parameters related to altitude, temperature, air quality, pollen count and humidity. In various embodiments, parameters available to be displayed that are associated with a diet parameter type include, but are not limited to, parameters related to sodium intake, fluid intake and lipid intake.

FIG. 14 illustrates a block diagram of a wellness trending display illustrating an arrangement for selecting and displaying parameter trends according to various embodiments of the present subject matter. In the illustrated embodiment, the screen display 1460 of the WMD includes a patient health trend area 1468A, a device trend area 1468B, and a trend display area 1468C. In various embodiments, the screen display includes a time indicator 1469 and an event identifier 1470. The event identifier is used to display predetermined events. In various embodiments, significant events include events that are clinically important in themselves, those events that may trigger clinically important changes, and/or those events that explain clinically important changes. The illustrated screen display promotes the correlation of various parameter trends to various predetermined events. The correlation of various parameter trends is useful to diagnose and treat various health conditions.

In various embodiments, various trended parameters from the patient health trend area and from the device trend area are capable of being displayed in the trend display area. In various embodiments, a user is capable of selecting the displayed parameters and/or is capable of modifying the scale, arrangement and/or other display characteristic.

The illustrated patient health trend area 1468A includes a physical parameter type 1461, a physiological/pathological parameter type 1462, a mental/emotional parameter type 1463, an environmental parameter type 1464, a diet parameter type 1465, a symptom parameter type 1466 and a

medication condition parameter type **1467**. In various embodiments, selecting the parameter type displays a second window for selecting a particular parameter associated with that parameter type. For example, selecting the physical parameter type button displays available physical parameters for display such as activity, posture and sleep. Other embodiments provide other ways for a user to select the parameters to be displayed.

The illustrated device trend area **1468C** includes parameters associated with the device that can affect the sensed parameters or that otherwise provide context to the sensed parameters. In various embodiments of the present subject matter which include a pulse generator IMD, the device trend area includes battery impedance **1471**, lead impedance **1472**, and percent pacing **1473**. One of ordinary skill in the art will understand, upon reading and comprehending this disclosure, the significance of device trends such as battery impedance, lead impedance, percent pacing and the like. One of ordinary skill in the art will further understand, upon reading and comprehending this disclosure, the desirability of correlating device trends with the patient health trends.

A number of parameters trends, shown as trend **1**, trend **2** . . . trend **n**, are capable of being displayed in the trend display area **1468B**. The trends are plotted as a function of time, which is illustrated at **1469**. In various embodiments, and event identifier, represented at **1470**, is also displayed in the trend display area. The event identifier displays predetermined events that occurred at various times, and assists with determining causes for changes in the displayed parameter trends.

FIG. **15** illustrates an example of a wellness trending display. In the illustrated embodiment, the screen display of the wellness monitor device includes a patient health trend area **1566**, a device trend area **1568**, and a trend display area **1567**.

In the illustrated embodiment, a number of patient health parameter trends are accessible in the patient health trend area, including mean resting heart rate trends, an activity trends, standard deviation of averaged normal-to-normal (SDANN) interval trends, percent atrial fibrillation (AF) trends, intrinsic PR interval trends (the period of time from the onset of the P wave (atrial depolarization) to the onset of the QRS complex (ventricular depolarization)), autonomic balance trends, and mean resting respiratory trends.

SDANN is a particular measure of heart rate variability (HRV) that is based on 24 hour recordings of heartbeats. SDANN is computed by determining average heart rate over a given interval (e.g. five (5) minute intervals), and taking the standard deviation of the heart rates. Preferably, the SDANN measure uses every interval during the day assuming that all of the intervals provide good recordings. For example, there are 288 5-minute periods during a day. If all of the intervals provide good recordings, the SDANN is the standard deviation of these 288 averages. However, since all of the recordings may not be good throughout the 24 hour day, the SDANN is computed from the good portions of the recording.

Upon reading and understanding this disclosure, those skilled in the art will readily understand the value of the heart rate, percent atrial fibrillation, autonomic balance, and respiratory trends in the context of patient wellness. The intrinsic PR interval is useful to determine optimal cardiac resynchronization therapy in heart failure patients.

In the illustrated embodiment, a number of device trends **1568** are accessible in the device trend area, including percent ventricular pacing trends, atrial lead impedance trends, RV lead impedance trends, LV lead impedance

trends, atrial intrinsic amplitude trends, right ventricular amplitude trends, and left ventricular amplitude trends. Upon reading and comprehending this disclosure, those skilled in the art will readily understand the value of the parameters in assessing device functionality and thereby the ability of the device to deliver proper therapy.

Labels are provided in FIG. **15** to illustrate the correlation between various parameter trends and various predetermined events. For example, programming the IMD, as indicated by the event identifier, resulted in a lower resting mean heart rate and an increased activity. U.S. Pat. No. 6,021,351, issued to Kadhiresan et al. and entitled Method and Apparatus For Assessing Patient Well-Being, describes an example of an activity. U.S. Pat. No. 6,021,351 is assigned to Applicant's assignee, and is hereby incorporated by reference in its entirety. The illustration also shows that a ventricular tachycardia (VT) shock therapy did not significantly affect the heart rate or activity, but that atrial fibrillation (AF>15%) significantly worsened the patient's health status as indicated by an increased resting mean heart rate and a decreased activity. One of ordinary skill in the art will understand, upon reading and comprehending this disclosure, that other parameters and predetermined events can be acquired and displayed to illustrate the correlation between various parameter trends and various predetermined events.

FIG. **16** illustrates a block diagram according to various aspects of the present subject matter in which a diagnostic context is provided to assist with interpreting the health condition of the patient, and to appropriately adjust the device and/or medical therapy, accordingly. The patient diagnostics **1669** and the diagnostic context **1670** are capable of being acquired using a variety of IMD and external sources, such as those provided throughout this disclosure. A number of patient diagnostics and diagnostic contexts are provided in FIG. **15**, and will not be repeated in this specification.

In the illustrated embodiment, the diagnostic context **1670** is used as an input in forming the patient diagnosis **1669**. The diagnostic context and the patient diagnostics provide inputs to titration algorithms **1671**, which are used to determine an appropriate device therapy based on the diagnosis and the context of the diagnosis. The titrated settings for the device therapy are implemented by the device at **1672**. At **1673**, various trends, reports and/or alerts/alarms are determined based on the patient diagnostics. A physician **1674** receives these various trends, reports and/or alerts/alarms, along with other data **1675** such as clinical exams, clinical data, medical history and the like. Based on the available information, the physician is able to adjust (or titrate) the device therapy **1672** and/or the medical therapy **1676**. Defining, Identifying and Using Predetermined Health-Related Events

FIGS. **17-19** illustrate various embodiments of the present subject matter related to defining, identifying and using predetermined health-related events. In various embodiments, a device such as a WMD or IMD defines, identifies, displays and triggers actions based on a predetermined health-related event. In various embodiments, the predetermined events include significant events that are clinically important. Significant events includes those events that are clinically important in themselves (such as ventricular fibrillation), those events that trigger an important change (such as loss of ventricular pacing) or those events that explain a change (such as increased anxiety).

FIG. **17** illustrates a method for managing a patient's health by defining, detecting and using predetermined

health-related events, according to various embodiments of the present subject matter. At 1777, predetermined events are defined. In various embodiments, predetermined events are significant health-related events, such as events that are clinically important in themselves, events that trigger a change, and/or events that explain a change. Examples of predetermined events includes device (e.g. IMD) therapy changes initiated by the device and/or clinician, a drug therapy change initiated by the device and/or clinician, arrhythmic events, changes in trended parameters, and autonomously-identified parameter correlations.

At 1778, predetermined health-related events are detected based on health-related parameters. In various embodiments, the health-related parameters are acquire through IMD sensors, external sensors, external data sources such as patient databases, and/or manual data inputs. At 1779, the detected event is recorded in a time log. In various embodiments, a time stamp is associated with the event to record the time to of the event.

At 1780, an action is triggered based on the detected events. In various embodiments, the triggered action includes a change in device therapy, an alarm and/or a display or report of the predetermined events along with trended health-related parameters. In various embodiments, the triggered action includes initiating a signal for use within the device(s) that detected the events for transmission for use by other device(s).

FIG. 18 illustrates a device (such as a WMD or IMD) for monitoring a patient's health condition that is capable of detecting predetermined health-related events, according to various embodiments of the present subject matter. The illustrated device includes a parameter acquisition module 1881 to acquire health related parameters. These health-related parameters can include IMD parameters (whether sensed or device interrogated), and parameters from external data sources such as sensors and databases. Various embodiments acquire various health-related parameters that are provided throughout this disclosure. The illustrated device 1852 further includes a predetermined event detection module in communication with the parameter acquisition module. The predetermined event detection module 1882 communicates with the parameter acquisition module 1881 to determine whether the health-related parameter(s) correspond to at least one of the number of predetermined events. The illustrated device further includes an action trigger module 1883 to communicate with the predetermined event detection module and trigger at least one action appropriate for a detected predetermined event.

FIG. 19 illustrates a wellness monitoring device (WMD) for monitoring a patient's health condition that is capable of detecting predetermined health-related events, according to various embodiments of the present subject matter. The illustrated device 1952 includes a communication module 1984, a parameter acquisition module 1981, an input module 1985, a predetermined event definition module 1986, a timer module 1987 and a predetermined event detection module 1982. In operation, the modules perform the functions as described below.

The communication module 1984 receives at least one health-related parameter. The parameter acquisition module 1981 communicates with the communication module to acquire the at least one health-related parameter. The input module 1985 receives manual input data, such as data for defining predetermined events and/or parameters to be acquired by the parameter acquisition module 1981 through a communication link. The predetermined event definition module 1986 communicates with the input module 1985

and/or a memory storage that contains a set of predetermined health-related events 1988 to define a number of predetermined events for the patient's health condition. The predetermined event detection module 1982 communicates with the parameter acquisition module 1981 and the predetermined event definition module 1986 to determine that the health-related parameter(s) correspond to at least one of the number of predetermined events. The predetermined event detection module 1982 further communicates with the timer module 1987 to associate a time with the at least one of the number of predetermined events.

Various embodiments of the present subject matter include an action trigger module 1983 in communication with the predetermined event detection module. The action trigger module 1983 is adapted to trigger a desired action based on a detected predetermined event. In various embodiments, the action trigger is adapted to provide a signal to display the detected predetermined event along with a trend for the at least one health related parameter. In various embodiments, the device includes a display on which the predetermined event and the trend for the at least one health related parameter are displayed. In various embodiments, the signal is transmitted to another device with a display on which the predetermined event and the trend for the at least one health related parameter are displayed. In various embodiments, the action trigger is adapted to provide a signal to send an alarm in response to the detected predetermined event. Various embodiments of the present subject matter include an action trigger to provide a signal to change device therapy in response to the detected predetermined event.

The health-related parameters acquired by the parameter acquisition module 1981 are capable of including IMD parameters or health-related parameters from an external data source such as external sensors, patient history databases, databases accessible through a global computer network (e.g. Internet), and user inputs (e.g. manual inputs from a patient and/or clinician).

Reporting Multiple Health-Related Parameters

FIGS. 20-21 illustrate various embodiments of the present subject matter related to reporting multiple health-related parameters. Various embodiments of the present subject matter provide a number of methods for transferring trended data, predetermined events and alerts to a clinician. In various embodiments, this type of information is capable of being displayed on a programmer screen or being otherwise used by a WMD and/or IMD within an advanced patient management system, such as those described within this disclosure, for example. This information is filtered in various embodiments of the present subject matter such that only the most relevant or clinically useful information is displayed or otherwise used.

FIG. 20 illustrates a method for reporting multiple parameters related to a health condition of a patient, according to various embodiments of the present subject matter. At 2088, a number of trended health-related parameters are acquired. In various embodiments, the trended health-related parameters include any of the various parameters described within this disclosure. In various embodiments, acquiring the trended health-related parameters includes acquiring parameters and trending the acquired parameters. At 2089, a number of predetermined events are acquired. In various embodiments, the predetermined events include events that are clinically important in themselves, events that trigger a change, or events that explain a change. In various embodiments, acquiring predetermined events include determining that the event is a significant health-related event as pro-

vided elsewhere in this disclosure. At **2090**, a number of alerts are acquired. In various embodiments, acquiring alerts includes determining alerts. Alerts in various embodiments of the present subject matter include device-initiated alerts, patient-initiated alerts, and clinician-initiated alerts. Additionally, alerts in various embodiments of the present subject matter include alerts directed to the patient and alerts directed to a clinician.

At **2091**, the present subject communicates at least one of the parameters, events and/or alerts. Various embodiments prioritize or characterize the relevance of the parameters, events and/or alerts, and appropriately communicate the information according to the relevance of the information. In various embodiments, the parameters, events and/or alerts are communicated in a report-like manner. Various embodiments of the present subject matter communicate the parameters, events and/or alerts incorporating a variety of communication technologies provided in this disclosure. In various embodiments, the communication displaying the parameters, events and/or alerts, providing an alarm signal with respect to the parameters, events and/or alerts, transmitting an e-mail, transmitting a telefax, placing a telephone call, and conducting wireless communication.

FIG. **21** illustrates a wellness monitoring device (WMD) for monitoring a patient's health condition that is capable of prioritizing communication of health-related parameters, according to various embodiments of the present subject matter. The illustrated device **2152** includes a communication module **2184**, a parameter acquisition module **2181**, an input module **2185**, a predetermined event definition module **2186**, a timer module **2187**, a predetermined event detection/acquisition module **2182**, and an alert acquisition module **2192**. In operation, the modules perform the following functions. The communication module **2184** receives at least one health-related parameter. The parameter acquisition module **2181** communicates with the communication module **2184** to acquire the at least one health-related parameter. The input module **2185** receives manual input data, such as data for defining predetermined events and/or parameters acquired by the parameter acquisition module **2181** through a communication link. The predetermined event definition module **2186** communicates with the input module **2185** to define a number of predetermined events for the patient's health condition. The predetermined event detection/acquisition module **2182** communicates with the parameter acquisition module **2181** and the predetermined event definition module **2186** to determine that the health-related parameter(s) correspond to at least one of the number of predetermined events. The predetermined event acquisition module **2182** further communicates with the timer module **2187** to associate a time with the at least one of the number of predetermined events. The alert acquisition module **2192** communicates with the predetermined event acquisition module **2182** and with an alert definition module **2193** to determine alerts from, among other things, the acquired predetermined events.

Various embodiments of the present subject matter include an output communication module **2194** in communication with the alert acquisition module **2192**, the predetermined event acquisition module **2182** and the parameter acquisition module **2181**. In various embodiments, the output communication module **2194** is in communication with a priority filter **2195** for characterizing or classifying the relevance of the parameter(s), event(s) and/or alert(s). The output communication module **2194** is adapted to appropri-

ately communicate the parameter(s), event(s) and/or alert(s) using various communication technologies based on their relevance.

One of ordinary skill in the art will understand, upon reading and comprehending this disclosure, how to acquired parameters, events and/or alerts using an IMD, and transmitting a communication signal represented the acquired parameters, events and/or alerts from the IMD to assist with managing a patient's health.

Environmental Data

FIG. **22** illustrates various embodiments of the present subject matter related to reporting environmental data. Various embodiments of the present subject matter automatically acquire and present environmental data to the attending physicians and/or patients for disease diagnosis and therapy decision making. For example, chronically ill patients can be very sensitive to the environment changes such as air quality and temperature. Patients who have respiratory disorders secondary to cardiovascular diseases (e.g. HF) may be vulnerable to certain environmental conditions. For example, acute exacerbation sometimes can be attributed to environmental changes. In various embodiments, a device (such as an IMD and/or WMD) is able to automatically acquire environmental data and provide such information in correlation to other measurements of the patient conditions to the clinician and/or patient.

FIG. **22** illustrates a device (such as a WMD or IMD) for monitoring a patient's health condition that is capable of synthesizing environmental parameters with implantable medical device (IMD) parameters, according to various embodiments of the present subject matter. Examples of environmental parameter types include, but are not limited to, parameters related to altitude, temperature, air quality, pollen count, and humidity. The illustrated device **2252** includes a first communication module **2296** for receiving IMD parameters, and a second communication module **2297** for receiving environmental parameters from a source of environmental parameters (such as an external sensor or a database). The device includes a correlation module **2298** that receives the IMD parameter(s) and the environmental parameter(s), and correlates the environmental parameters with the IMD parameters.

Various embodiments of the present subject matter include an action trigger module **2283** in communication with the correlation module **2298**. The action trigger module **2283** is adapted to trigger a desired action based on the IMD parameter(s) and the environmental parameter(s). In various embodiments, the action trigger module **2283** is adapted to provide a signal to display the correlation between the IMD parameter(s) and the environmental parameter(s).

In various embodiments, the device **2252** includes a display on which the correlation between the IMD parameter(s) and the environmental parameter(s) is displayed. In various embodiments, the signal is transmitted to another device with a display on which the correlation between the IMD parameter(s) and the environmental parameter(s) is displayed. In various embodiments, the action trigger is adapted to provide a signal to send an alarm in response to the correlation between the IMD parameter(s) and the environmental parameter(s). Various embodiments of the present subject matter include an action trigger module **2283** to provide a signal to change device therapy in response to the correlation between the IMD parameter(s) and the environmental parameter(s).

In various embodiments, the device **2252** further includes a third communication module **2299** to receive IMD position parameters. Thus, for example, in an embodiment in which

the second communication module is accessing environmental parameter(s) from a database of regional environmental parameters, the present subject matter is capable of determining the appropriate region for which to retrieve environmental parameters. Additionally, in various embodiments, the IMD position parameters include parameters indicative of altitude. According to various embodiments, the IMD position parameters are generated using cellular technology to determine a cell region, GPS technology, and manual data inputs.

Various embodiments of the present subject matter relate to an advanced patient management system. In various embodiments, the system includes at least one implantable medical device (IMD) to acquire at least one IMD parameter indicative of patient wellness, means to acquire at least one environmental parameter from at least one external source, and means to factor in the at least one environmental parameter in the advanced patient management system. In various embodiments, the environmental parameter is factored in by adjusting the IMD parameter based on the at least one environmental parameter. In various embodiments, the environmental parameter is factored in by adjusting a display of the IMD parameter. In various embodiments, the environmental parameter is factored in by adjusting IMD-provided therapy (such as electrical therapy, drug therapy, and the like). A number of environmental parameter types are acquired in various embodiments. Examples of these environmental types include altitude, temperature, air quality, pollen counts, humidity, and pressure. In various embodiments, the IMD parameter(s) and/or the environmental parameter(s) are trended and/or correlated, as provided in this disclosure.

Identifying, Displaying and Assisting in Correlating Health-Related Data

FIG. 23 illustrates various embodiments of the present subject matter related to identifying, displaying and assisting in data correlation. One definition of correlation is a relation existing between phenomena or things or between mathematical or statistical variables which tend to vary, be associated, or occur together in a way not expected on the basis of chance alone. Correlating data involves showing a reciprocal, mutual, and/or causal relationship among the data.

Various embodiments of the present subject matter provide methods of correlating, or assisting in the correlation of, trended data, predetermined events and other actions taken by the system (such as an alert transmitted to the clinician). Various embodiments of the present subject matter autonomously identify correlations and display the identified correlations. For example, various embodiments determine correlations without human intervention. In various embodiments, the present subject matter assists the clinician in correlating the information by displaying the data in an appropriate manner. Cause and effect relationships that are suitable for use in treating patients can be established by correlating data items.

FIG. 23 illustrates a device (such as a WMD or IMD) for monitoring a patient's health condition that is capable of correlating trended parameters, predetermined events, and alerts, according to various embodiments of the present subject matter. The illustrated device 2352 includes a first data input 2301 to receive trended health-related parameter(s), a second data input 2302 to receive predetermined event(s) associated with a patient's health, and a third data input 2303 to receive alert(s) associated with a patient's health. According to various embodiments of the present subject matter, the health-related parameters, the predeter-

mined events, and the alerts include any of the health-related parameters, the predetermined events, and the alerts provided throughout this disclosure.

The device 2352 includes a correlation module 2304 in communication with the first data input 2301, the second data input 2302, and the third data input 2303. The correlation module 2304, which in uses various correlation algorithms 2305 in various embodiments, is adapted to correlate at least one of one or more trended health-related parameters, one or more health-related predetermined events, and one or more health-related alerts. In various embodiments, the correlation module 2304 is adapted to trigger an action. In various embodiments, the action is automatically triggered based on the correlation. In various embodiments, the correlation module automatically triggers an IMD therapy change based on the correlation. In various embodiments, the correlation module automatically displays the correlation. For example, a cursor or other indicator can be used to highlight the correlation.

Those versed in the art will understand, upon reading and comprehending this disclosure, how to incorporate various well known techniques for computing correlations between two or more data sources. For example, in the case of providing correlations between two data sources, Pearson's product-moment correlations is one example of a type of correlation that may be computed. In the case of three or more data sources, multivariate correlation techniques may be employed.

According to various embodiments of the present subject matter, the choice of which data sources to correlate is based on knowledge of physiological coupling between the sources. According to various embodiments, the choice of which data sets to correlate and the time durations(s) over which the correlations are computed is determined at the start of monitoring, and is either the same for each patient, or is tailored to individual patients based on the physicians' knowledge of the patient's condition. In various embodiments, the decisions of which parameters to correlate with each other may be dynamically selected based on ongoing IMD or WMD monitoring of the patient's physiology.

Composite Parameter Indices

FIGS. 24-26 illustrate various embodiments of the present subject matter related to defining, identifying and utilizing composite parameter indices. A composite parameter is a parameter created by combining two or more parameter inputs. For example an exercise conditioning composite parameter is generated by dividing a heart rate by an activity level. A lower exercise condition composite parameter indicates that a patient is in better condition. Various embodiments of the present subject matter provide composite parameters that function as trended parameters in various manner in which the trended parameters are used, as provided throughout this disclosure. A composite parameter is capable of being used in any way a raw parameter is used, such as displaying, correlating, defining predetermined events, defining alerts, and the like.

FIG. 24 illustrates a method to generate composite parameters for use in managing a patient's health, according to various embodiments of the present subject matter. The method illustrates a first parameter 2406 and a second parameter 2407 being operated on to form a composite parameter 2408. One or ordinary skill in the art will understand, upon reading and comprehending this disclosure, that the operation denoted at 2409 can be any number of mathematical and/or logical operations. For example, the composite parameter 2408 can be formed by multiplying the first parameter 2406 and the second parameter 2407, or can be

formed by dividing the second parameter 2407 into the first parameter 2406. More complex mathematical and/or logical operations can be used to generate the composite index.

FIG. 25 illustrates a method to generate composite parameters for use in managing a patient's health, according to various embodiments of the present subject matter. The method illustrates a number of parameters (1, 2, P) and a number of composite parameters (1, 2, C) that are capable of being combined to form one or more composite parameters 2508. Thus, the present subject matter is capable of generating a composite parameter from any number of health-related parameters, from any number of previously-determined composite parameters, or from any combination of one or more parameters and one or more composite parameters.

In various embodiments, the parameters include IMD-measured parameters and/or IMD-interrogated parameters. IMD-interrogated parameters include, for example, parameters related to a device status such as battery or lead impedance. In various embodiments, the parameters include user-inputted parameters provided by a patient, clinician or other person.

Various embodiments of the present subject matter combine two or more health-related parameters related to a body system to generate a composite parameter that is indicative of the health of the body system. For example, respiratory rate, tidal volume, maximum oxygen consumption (VO₂) and periodic breathing parameters relate to a respiratory system. These parameters can be used to generate a single composite parameter index that provides a health indication concerning the respiratory system. Another example uses an average heart rate and an activity parameter to generate a composite parameter index indicative of physical conditioning. Other examples use cardiac output and vascular pressures to measure vascular resistance. Another example measures respiration and heart rate to measure respiratory sinus arrhythmia.

In various embodiments, the composite index is displayed with trended health-related parameter(s), predetermined event(s) and/or alert(s). In various embodiments, the composite parameter is used to define a predetermined health-related event. In various embodiments, the composite parameter is used to define a clinician alert. In various embodiments, the composite parameter is used to modify device therapy.

FIG. 26 illustrates a device (such as a WMD or IMD) for monitoring a patient's health condition that is capable of generating composite parameters, according to various embodiments of the present invention. The illustrated device 2652 includes a data input 2610 to receive two or more health-related parameters and a composite generating module 2611 in communication with the data input 2610. In operation, the composite generating module 2611 receives the health-related parameters and generates a composite parameter using the health-related parameters. The composite generating module 2611 is capable of performing any number of mathematical and/or logical operations, such as that denoted at 2409 in FIG. 24. In various embodiments, the composite generating module 2611 is capable of combining one or more composite parameters (represented by line 2612) with one or more health-related parameters to form other composite parameters.

Various embodiments provide various composite parameters. A number of these composite parameters are identified below. The identified composite parameters is not intended to be an exclusive list of the available composite parameters.

In a first example, a composite parameter indicative of systemic vascular resistance (SVR) is generated using an acquired cardiac output parameter (C.O.), a mean arterial pressure parameter (P_{ART}), and a mean right atrial pressure parameter (P_{RA}). In various embodiments, the SVR composite parameter is provided by:

$$SVR = \frac{P_{ART} - P_{RA}}{C.O.}$$

In a second example, a composite parameter indicative of pulmonary vascular resistance (PVR) is generated using an acquired cardiac output parameter (C.O.), a mean pulmonary artery pressure parameter (P_{PA}), and one of a mean pulmonary capillary wedge pressure parameter (P_{CW}) and a mean left atrial pressure parameter (P_{LA}). In various embodiments, the PVR composite parameter is provided by:

$$PVR = \frac{P_{PA} - P_{CW}}{C.O.}, \text{ or } PVR = \frac{P_{PA} - P_{LA}}{C.O.}$$

In a third example, a composite parameter indicative of respiratory sinus arrhythmia (RSA) is generated using an acquired heart rate parameter (P_{HR}) and a parameter related to instantaneous lung volume (P_{LV}). For example, a trans-thoracic sensor can be used in the acquisition. In various embodiments, the RSA composite parameter is provided by:

$$RSA = f(P_{HR}, P_{LV}).$$

In a fourth example, a composite parameter indicative of a degree of dyspnea (D) is generated using an acquired respiration rate parameter (P_{RR}) and a tidal volume parameter (P_{TV}). In various embodiments, the dyspnea composite parameter is provided by:

$$D = \frac{P_{RR}}{P_{TV}}$$

Context may temporarily affect the physiological condition of a monitored patient. A patient context (or body-related concept), for example, may include posture, activity level, mental/emotional state and the like. Examples of patient contexts include sleeping or lying down, running, and driving. An environmental context (or external factor), for example, may include ambient temperature, sound level and the like. The concept of context has previously been discussed with respect to FIG. 16.

In various embodiments, the context is correlated with the physiologic measurements. In various embodiments, measurements are taken only for certain contexts so as to provide a repeatable baseline. For example, it is preferred to measure some parameters when a patient is at rest or in a known position. Thus, repeatable composite parameters can be generated. This is useful to determine trends or deviations from normal values. Additionally, various embodiments determine the context to provide an appropriate therapy for a contextual situation.

The following commonly-assigned patent applications refer to the use of multiple parameters and are herein incorporated by reference in their entirety: "Implantable Cardiac Rhythm Management Device For Assessing Status of CHF Patients," Ser. No. 09/434,009, filed Nov. 4, 1999, now U.S. Pat. No. 6,275,727; "Method and Apparatus For

Determining Changes In Heart Failure Status,” Ser. No. 10/001,223, filed Nov. 15, 2001, now U.S. Pat. No. 6,980, 851; and “Cardiac Rhythm Management Systems and Methods Predicting Congestive Heart Failure Status,” Ser. No. 10/213,268, filed Aug. 6, 2002, now U.S. Pat. No. 7,127, 290. The following commonly-assigned patent application refers to context and is herein incorporated by reference in its entirety: “Methods and Devices For Detection of Context When Addressing A Medical Condition of a Patient”, Ser. No. 10/269,611, filed Oct. 11, 2002, now U.S. Pat. No. 7,400,928.

Cardiac failure refers to a condition in which the heart fails to pump enough blood to satisfy the needs of the body. It is usually due to some damage to the heart itself, such as from a myocardial infarction or heart attack. When heart failure occurs acutely, autonomic circulatory reflexes are activated that both increase the contractility of the heart and constrict the vasculature as the body tries to defend against the drop in blood pressure. Venous constriction, along with the reduction in the heart’s ability to pump blood out of the venous and pulmonary systems (so-called backward failure), causes an increase in the diastolic filling pressure of the ventricles. This increase in preload (i.e., the degree to which the ventricles are stretched by the volume of blood in the ventricles at the end of diastole) causes an increase in stroke volume during systole, a phenomena known as the Frank-Starling principle. If the heart failure is not too severe, this compensation is enough to sustain the patient at a reduced activity level. When moderate heart failure persists, other compensatory mechanisms come into play that characterize the chronic stage of heart failure. The most important of these is the depressing effect of a low cardiac output on renal function. The increased fluid retention by the kidneys then results in an increased blood volume and further increased venous return to the heart. A state of compensated heart failure results when the factors that cause increased diastolic filling pressure are able to maintain cardiac output at a normal level even while the pumping ability of the heart is compromised.

Compensated heart failure, however, is a precarious state. If cardiac function worsens or increased cardiac output is required due to increased activity or illness, the compensation may not be able to maintain cardiac output at a level sufficient to maintain normal renal function. Fluid then continues to be retained, causing the progressive peripheral and pulmonary edema that characterizes overt congestive heart failure. Diastolic filling pressure becomes further elevated which causes the heart to become so dilated and edematous that its pumping function deteriorates even more. This condition, in which the heart failure continues to worsen, is decompensated heart failure. It can be detected clinically, principally from the resulting pulmonary congestion and dyspnea, and all clinicians know that it can lead to rapid death unless appropriate therapy is instituted.

Resynchronization pacing is effective in treating heart failure because pump function is improved when the ventricles are caused to contract in a more coordinated manner. Heart failure can also be treated medically with diuretics to decrease fluid retention, vasodilators to decrease preload and afterload, and inotropic agents to increase myocardial contractility. All of these treatment modalities need to be optimized for the individual patient, and therapy adjustments need to be made when a patient’s heart failure status changes if the progressive heart failure described above is to be avoided.

Studies have shown that patients with chronic heart failure are limited by exertional dyspnea and exercise intol-

erance. Such patients often exhibit elevated ventilatory response to exercise, which can be characterized by a steeper slope relating minute ventilation to carbon dioxide output during exercise. In addition to the increased ventilation, such patients have also been noted to have an abnormal breathing pattern, such that at a given minute ventilation, respiratory rate is increased while the change in tidal volume is less significant compared with normal subjects. The ventilatory response to exercise, as characterized by the regression slope relating minute ventilation to carbon dioxide output during exercise by CHF patients, has been found to be significantly higher in such patients than for normal subjects.

The status of heart failure can be detected from the resulting pulmonary congestion and dyspnea. Transthoracic impedance can provide an estimate of minute ventilation, respiratory rate and tidal volume, and can be used to provide congestive heart failure status.

Triaging Health-Related Data

FIGS. 27-28 illustrates various embodiments of the present subject matter related to triaging health-related data in an advanced patient management system. Various embodiments of the present subject matter provide one or more devices (such as IMD, WMD, programmer and the like) with the ability to rank the severity of predetermined events. This ranking is used to prioritize the processing of the predetermined events and respond in an appropriate manner. For example, the system can be designed such that a modest increase in heart rate holds a lower priority and is related to the clinician at a next patient followup; whereas a sudden increase in weight (which may be associated with acute decompensation in a heart failure patient) may be assigned a higher priority and immediately be communicated to the clinician through various communication means.

FIG. 27 illustrates a method to triage predetermined events for use in managing a patient’s health, according to various embodiments of the present subject matter. At 2713, predetermined events are acquired. At 2714, the acquired predetermined events are classified, ranked, sorted or filtered according to severity. At 2715, an action is triggered based on the severity of the predetermined event. According to various embodiments, the action includes one or more of displaying the predetermined event to a clinician at a patient followup visit 2716, alerting a clinician of the predetermined event at a patient followup visit 2717, initiating an alert for the patient 2718, altering device therapy 2719, and initiating an alert (such as a prompt emergency alert) to the clinician using an advance patient management system 2720. In various embodiments, the above-identified actions are performed for predetermined events that have been classified for increasing severity such that action 2716 is performed for a less severe event than action 2717, which is performed for a less severe event than action 2718, which is performed for a less severe event than action 2719, which is performed for a less severe event than action 2710. Other actions can be performed according to the severity of the predetermined event.

In various embodiments, the available actions to be performed are associated with various severity levels for predetermined events. This information is stored in a computer-readable memory such that a device is capable of performing an action that is associated with a detected predetermined event.

FIG. 28 illustrates a device (such as a WMD or IMD) for monitoring a patient’s health condition that is capable of classifying a number of predetermined events according to severity, and performing a system action based on the classification, according to various embodiments of the

present subject matter. The illustrated device **2852** includes an input module **2821** and a triage module **2822**.

In various embodiments, the input module **2821** acquires predetermined events. In various embodiments, the input module **2821** includes a predetermined event determination module **2823** to determine whether a predetermined event has occurred. In various embodiments, the input module **2821** includes a first communication module **2824** to acquire IMD parameters for use by the predetermined event determination module **2823**. In various embodiments, the input module **2821** includes a second communication module **2825** to acquire database parameters for use by the predetermined event determination module.

The triage module **2822** receives the predetermined event(s) and ranks or otherwise classifies, the predetermined events according to severity. In various embodiments, the device **2852** includes a triggering module **2826** in communication with the triage module **2822**. The triage module **2822** is adapted to automatically initiate a desired action by the triggering module **2826** based on the severity of the predetermined event. In various embodiments, the action initiated is appropriate for the severity of the event. In various embodiments, a communication or report is initiated by the device when a predetermined event is classified as being more severe. For example, the communication can be an alarm or a prominently displayed message. In various embodiments, a communication or report is provided during a subsequent patient follow-up session when a predetermined event is classified as being less severe. In various embodiments, the device **2852** automatically performs a desired system action selected from a number of available system actions. The action is selected based on the severity of the predetermined event.

Although specific embodiments have been illustrated and described herein, it will be appreciated by those of ordinary skill in the art that any arrangement which is calculated to achieve the same purpose may be substituted for the specific embodiments shown. This application is intended to cover any adaptations or variations of the present subject matter. It is to be understood that the above description is intended to be illustrative, and not restrictive. Combinations of the above embodiments, and other embodiments will be apparent to those of skill in the art upon reviewing the above description. The scope of the present subject matter should be determined with reference to the appended claims, along with the full scope of equivalents to which such claims are entitled.

What is claimed is:

1. A system for monitoring a heart failure patient, the system comprising:

a first sensor configured to acquire a first physiological or physical parameter and one or more second sensors configured to acquire one or more second physiological or physical parameters different than the first physiological or physical parameter;

at least one medical device configured to acquire an environmental parameter that is capable of affecting at least one of the first or the one or more second physiological or physical parameters; and

wherein the at least one medical device is configured to adjust the first or one or more second physiological or physical parameters based on the environmental parameter, and to determine a heart failure (HF) status indication using the adjusted first or one or more second physiological or physical parameters.

2. The system of claim **1**, further comprising a display for displaying one or more of the first and one or more second

physiological or physical parameters and the environmental parameter, wherein the at least one medical device is configured to adjust the displayed physiological or physical parameters based on the environmental parameter.

3. The system of claim **1**, wherein the at least one medical device includes an implantable medical device (IMD) and an external device communicatively coupled to the IMD, the external device configured to acquire an environmental parameter, and the IMD or the external device configured to determine the HF status indication using the first and one or more second physiological or physical parameters and the environmental parameter.

4. The system of claim **1**, wherein the at least one medical device is configured to:

determine a correlation between the environmental parameter and the first or one or more second physiological or physical parameters;

determine a change in the first or one or more second physiological or physical parameters to be attributable to a change in the environmental parameter based on the determined correlation; and

determine the HF status indication using the determined change attributably: to the change in the environmental parameter.

5. The system of claim **4**, further comprising a therapy circuit configured to deliver a heart failure therapy in response to a detected worsening HF status indication,

wherein the at least one medical device are configured to cooperate to program the heart failure therapy based on the determination that the change in the first or one or more second physiological or physical parameters is attributable to the change in the environmental parameter.

6. The system of claim **1**, wherein the first sensor includes a heart sound sensor configured to acquire the first physiological or physical parameter including a heart sound parameter indicative of cardiac systolic or diastolic function.

7. The system of claim **1**, wherein the second sensor includes one of the sensors selected from the group consisting of:

a heart rate sensor;

a respiration sensor to acquire a respiration parameter including a respiration rate, respiratory tidal volume, or a respiratory rhythm; and

an impedance sensor to acquire the second physiological or physical parameter including an impedance parameter indicative of edema.

8. The system of claim **1**, wherein the at least one medical device is configured to:

generate a composite parameter by combining (1) the change in first physiological or physical parameter and (2) the change in one or more second physiological or physical parameters; and

determine the HF status indication using at least the composite parameter.

9. The system of claim **8**, further comprising a third sensor configured to detect a third physiological or physical parameter indicative of patient chronic risk for developing worsening HF, wherein the at least one medical device are configured to generate the composite parameter further using the third physiological or physical parameters.

10. The system of claim **9**, wherein the third physiological or physical parameter includes a parameter selected from the group consisting of: a heart sound parameter, a physical activity, and a respiration rate.

11. The system of claim **1**, wherein the environmental parameter includes at least one environmental parameter

selected from the group consisting of: altitude, temperature, air quality, pollen counts, humidity, and environmental pressure.

12. The system of claim 11, wherein the at least one medical device includes an input circuit configured to acquire the environmental parameter from an external sensor or from a database that stores environmental parameter values.

13. A method for monitoring a heart failure patient, the method comprising:

sensing a first physiological or physical parameter via a first sensor and sensing one or more second physiological or physical parameters different than the first physiological or physical parameter via one or more second sensors;

acquire an environmental parameter via at least one medical device, the environmental parameter capable of affecting at least one of the first or the one or more second physiological or physical parameters;

adjusting the first or one or more second physiological or physical parameters based on the environmental parameter; and

determining a heart failure (HF) status indication using the adjusted first or one or more second physiological or physical parameters.

14. The method of claim 13, further comprising:

displaying, on a display, one or more of the first and one or more second physiological or physical parameters and the environmental parameter; and

adjusting the displayed physiological or physical parameters, via the at least one medical device; based on the environmental parameter.

15. The method of claim 13, comprising:

determining a correlation between the environmental parameter and the first or one or more second physiological or physical parameters; and

determining a change in the first or one or more second physiological or physical parameters to be attributable to a change in the environmental parameter based on the determined correlation.

16. The method of claim 15, further comprising: programming a heart failure therapy based on the determination that the change in the first or one or more second physiological or physical parameters is attributable to the change in the environmental parameter; and

delivering the programmed heart failure therapy in response to a detected worsening HF status indication.

17. The method of claim 13, wherein:

the first physiological or physical parameter includes a heart sound parameter indicative of cardiac systolic or diastolic function; and

the second physiological or physical parameter is selected from the group consisting of: a heart rate, a respiration parameter including a respiration rate, respiratory tidal volume, or a respiratory rhythm, and an impedance parameter indicative of edema.

18. The method of claim 13, wherein determining the HF status indication includes:

computing a composite parameter using (1) the change in first physiological or physical parameter and (2) the change in one or more second physiological or physical parameters; and

detecting the HF status indication based on the composite parameter.

19. The system of claim 18, wherein computing the composite parameter further includes using a third physiological or physical parameter indicative of patient chronic risk for worsening heart failure, the third physiological or physical parameter including a parameter selected from the group consisting of: a heart sound parameter, a physical activity, and a respiration rate.

20. The system of claim 13, wherein the environmental parameter includes at least one environmental parameter selected from the group consisting of: altitude, temperature, air quality, pollen counts, humidity, and environmental pressure.

* * * * *

专利名称(译)	先进的患者管理与环境数据		
公开(公告)号	US10092186	公开(公告)日	2018-10-09
申请号	US15/332609	申请日	2016-10-24
[标]申请(专利权)人(译)	心脏起搏器股份公司		
申请(专利权)人(译)	心脏起搏器, INC.		
当前申请(专利权)人(译)	心脏起搏器, INC.		
[标]发明人	HATLESTAD JOHN D STAHMANN JEFFREY E ZHU QINGSHENG		
发明人	HATLESTAD, JOHN D. STAHMANN, JEFFREY E. ZHU, QINGSHENG		
IPC分类号	A61B5/00 G16H50/30 G16H40/63 A61B7/04 A61B5/11 G06F19/00 A61B5/0205 A61B5/091 A61B5/08 A61N1/372 A61B5/053		
CPC分类号	A61B5/0031 G16H40/67 A61B5/0205 A61B5/1118 A61B7/04 A61N1/37282 G16H40/63 G16H50/30 A61B5/0022 A61B5/0537 A61B5/0816 A61B5/091 A61B2560/0247 A61B2560/0252 A61B2560/0257 A61N1/37252 G06F19/3418		
代理机构(译)	SCHWEGMAN和Lundberg & 沃斯纳, P.A.		
其他公开文献	US20170035297A1		
外部链接	Espacenet		

摘要(译)

公开了用于使用环境数据来管理医疗保健的系统, 设备和方法。一个方面是先进的患者管理系统。在各种实施例中, 该系统包括至少一个可植入医疗设备 (IMD) 以获取指示患者健康的至少一个IMD参数, 从至少一个外部源获取至少一个环境参数的装置, 以及至少关联至少一个环境参数的装置指示患者健康的一个参数和帮助患者健康护理决定的至少一个环境参数。本文提供了其他方面和实施方案。

