



(19) **United States**

(12) **Patent Application Publication**
Laszlo et al.

(10) **Pub. No.: US 2019/0196585 A1**
(43) **Pub. Date: Jun. 27, 2019**

(54) **INTERFACE FOR
ELECTROENCEPHALOGRAM FOR
COMPUTER CONTROL**

A61B 5/0484 (2006.01)
A61B 5/00 (2006.01)

(52) **U.S. Cl.**
CPC *G06F 3/015* (2013.01); *A61B 5/04012*
(2013.01); *A61B 5/0482* (2013.01); *G06F*
3/0482 (2013.01); *A61B 5/04845* (2013.01);
A61B 5/7203 (2013.01); *A61B 5/7267*
(2013.01); *A61B 5/04842* (2013.01)

(71) Applicant: **X Development LLC**, Mountain View,
CA (US)

(72) Inventors: **Sarah Ann Laszlo**, Mountain View, CA
(US); **Gabriella Levine**, San Francisco, CA (US); **Joseph Hollis Sargent**, San
Francisco, CA (US); **Phillip Yee**, San
Francisco, CA (US)

(21) Appl. No.: **15/855,845**

(22) Filed: **Dec. 27, 2017**

Publication Classification

(51) **Int. Cl.**
G06F 3/01 (2006.01)
A61B 5/04 (2006.01)
A61B 5/0482 (2006.01)

(57) **ABSTRACT**

A method for analyzing electroencephalogram (EEG) signals is disclosed. Information associated with two or more options is presented to a user. EEG signals from a sensor coupled to the user are received contemporaneously to the user receiving information associated with the two or more options. The EEG signals are processed in real time to determine which one of the options was selected by the user. In response to determining which one of the options was selected by the user, an action from one or more possible actions associated with the information presented to the user is selected. An output associated with the selected action is then generated.

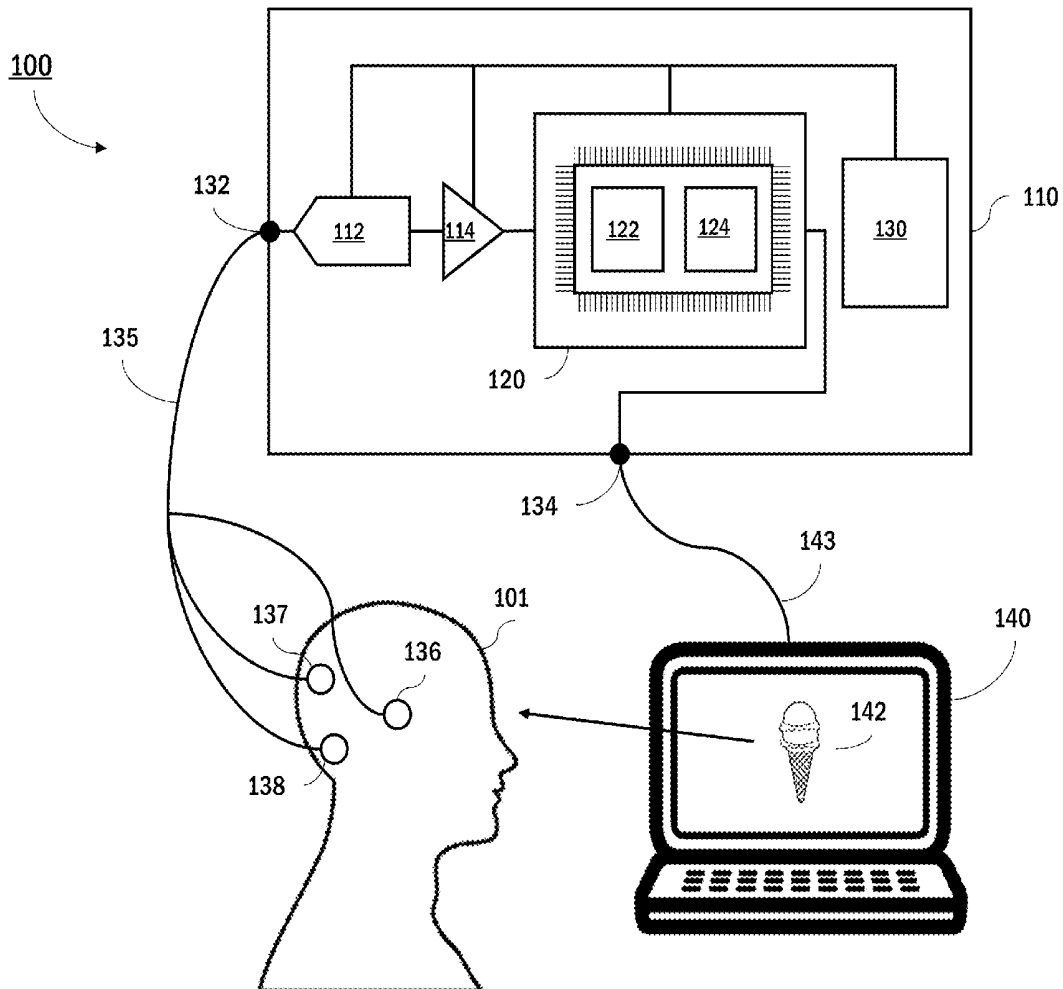

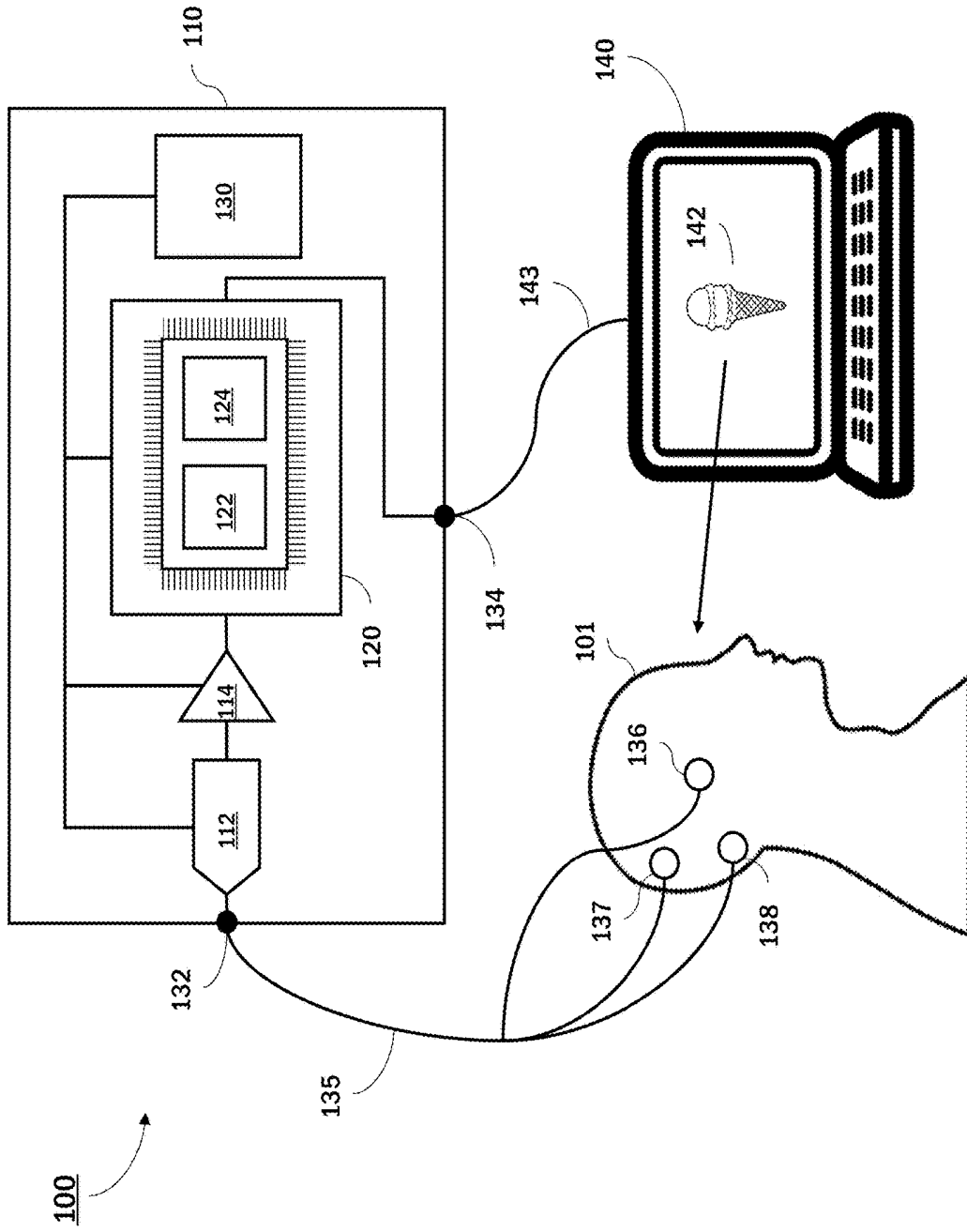

FIG. 1

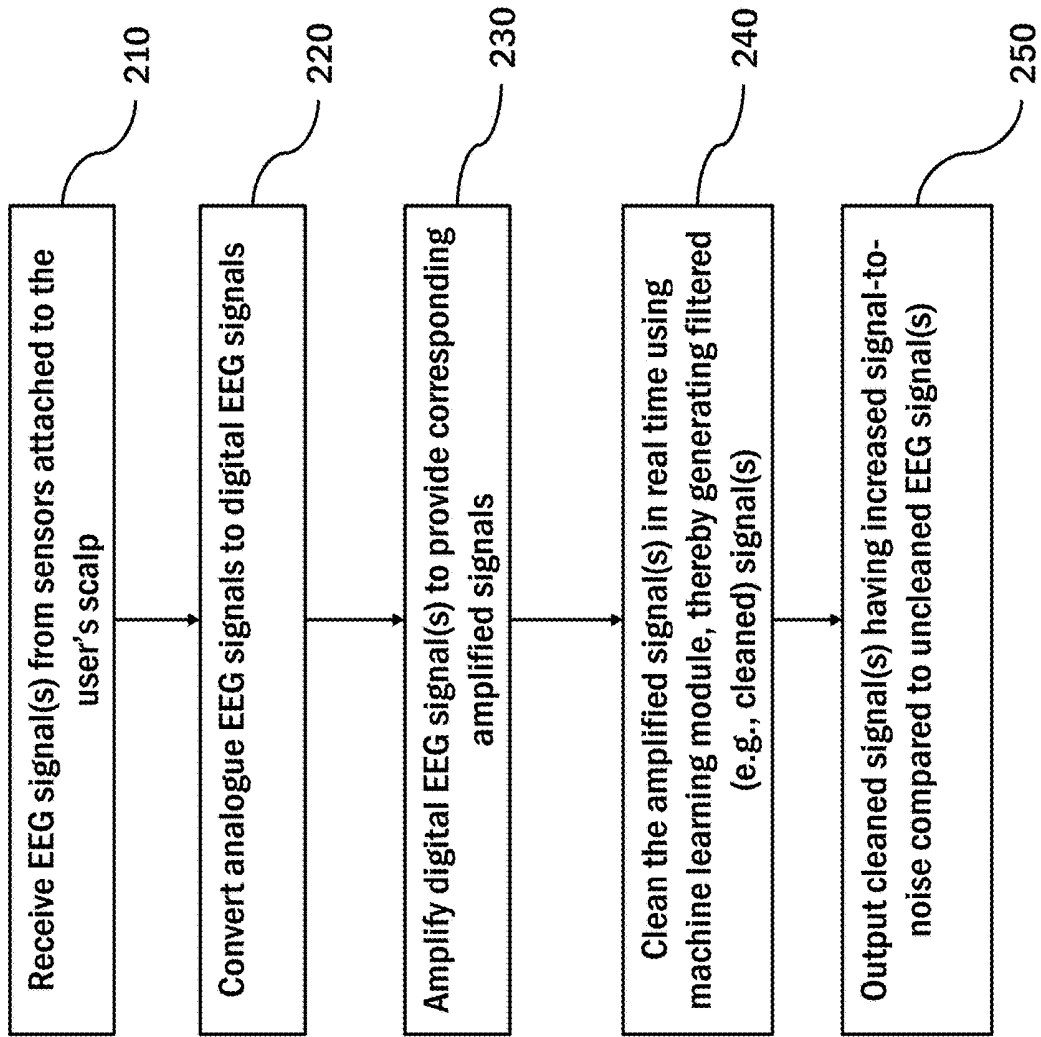
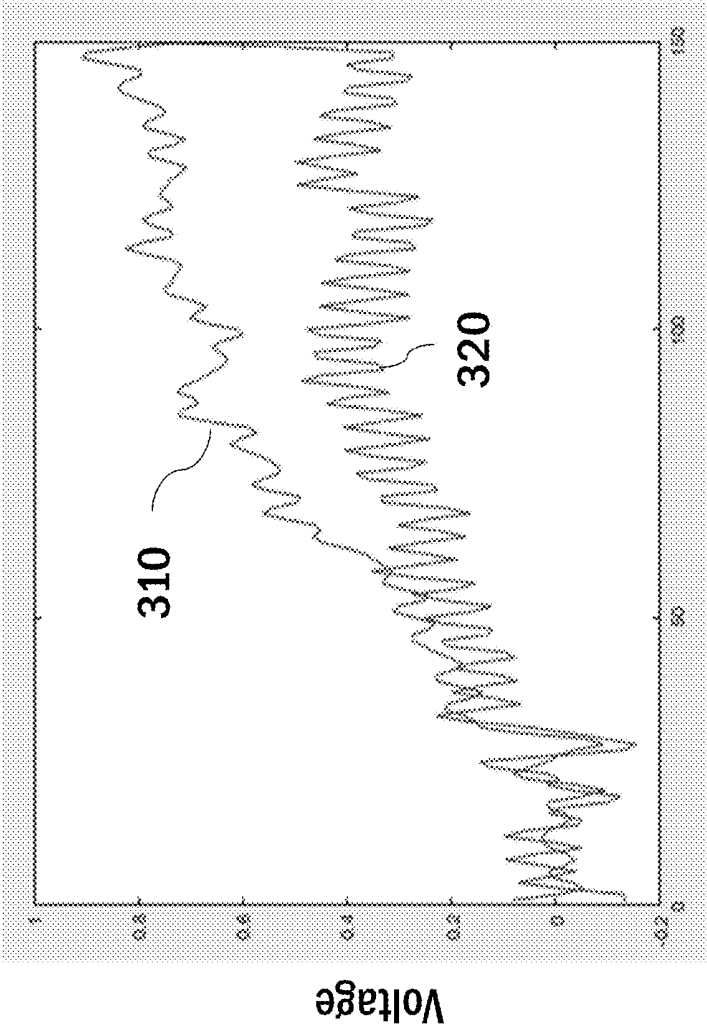

FIG. 2



Time (ms)

FIG. 3

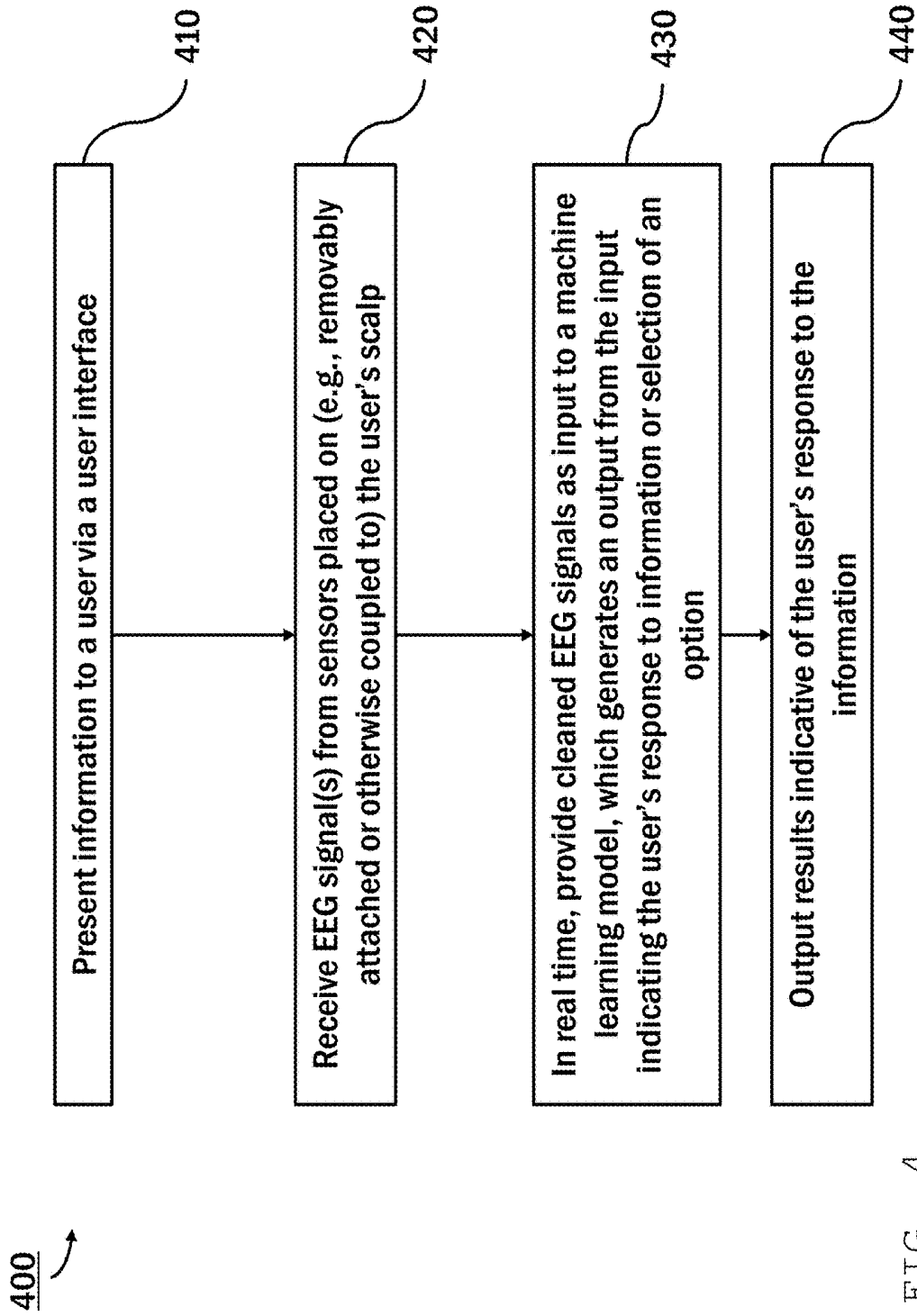
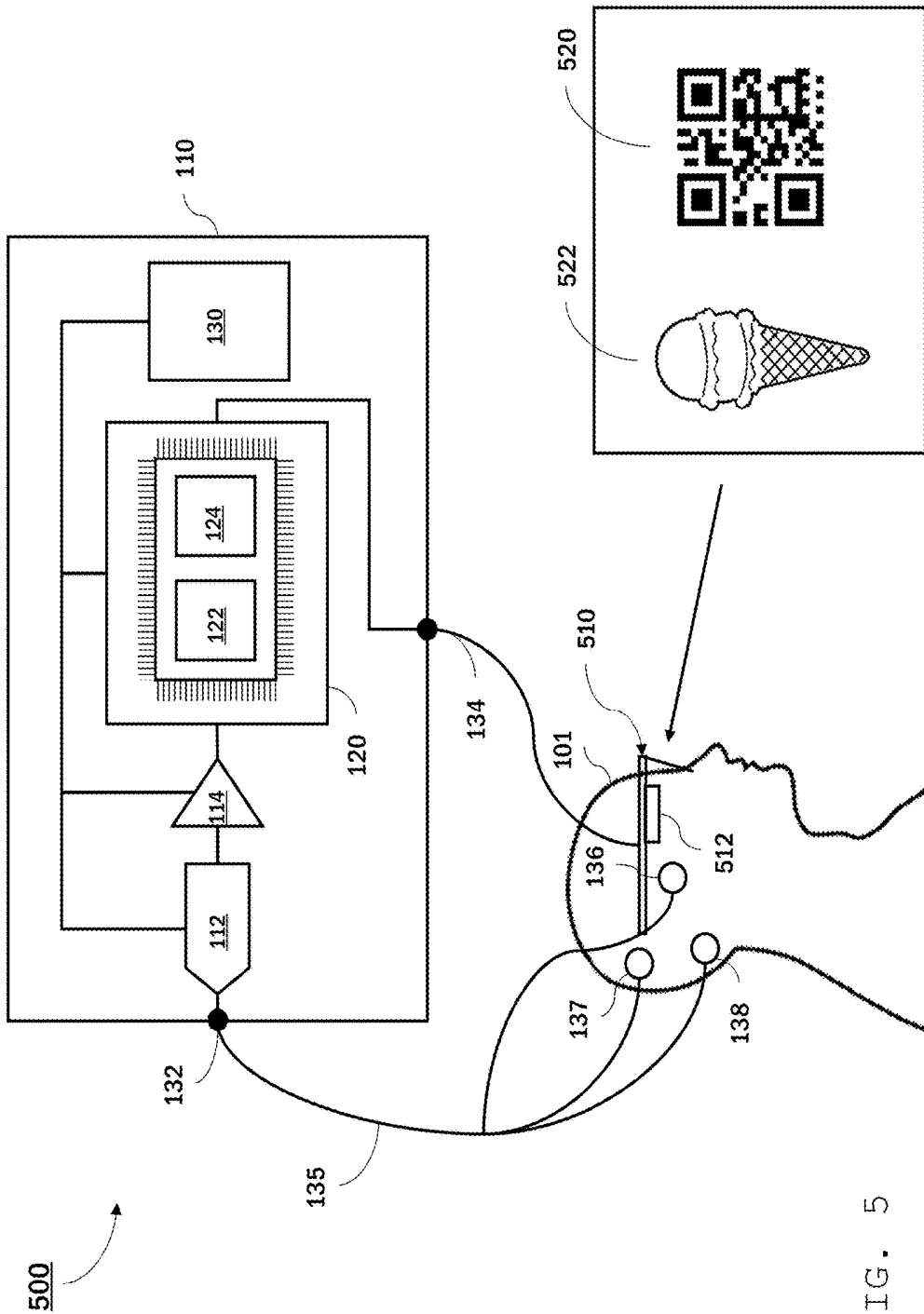

FIG. 4



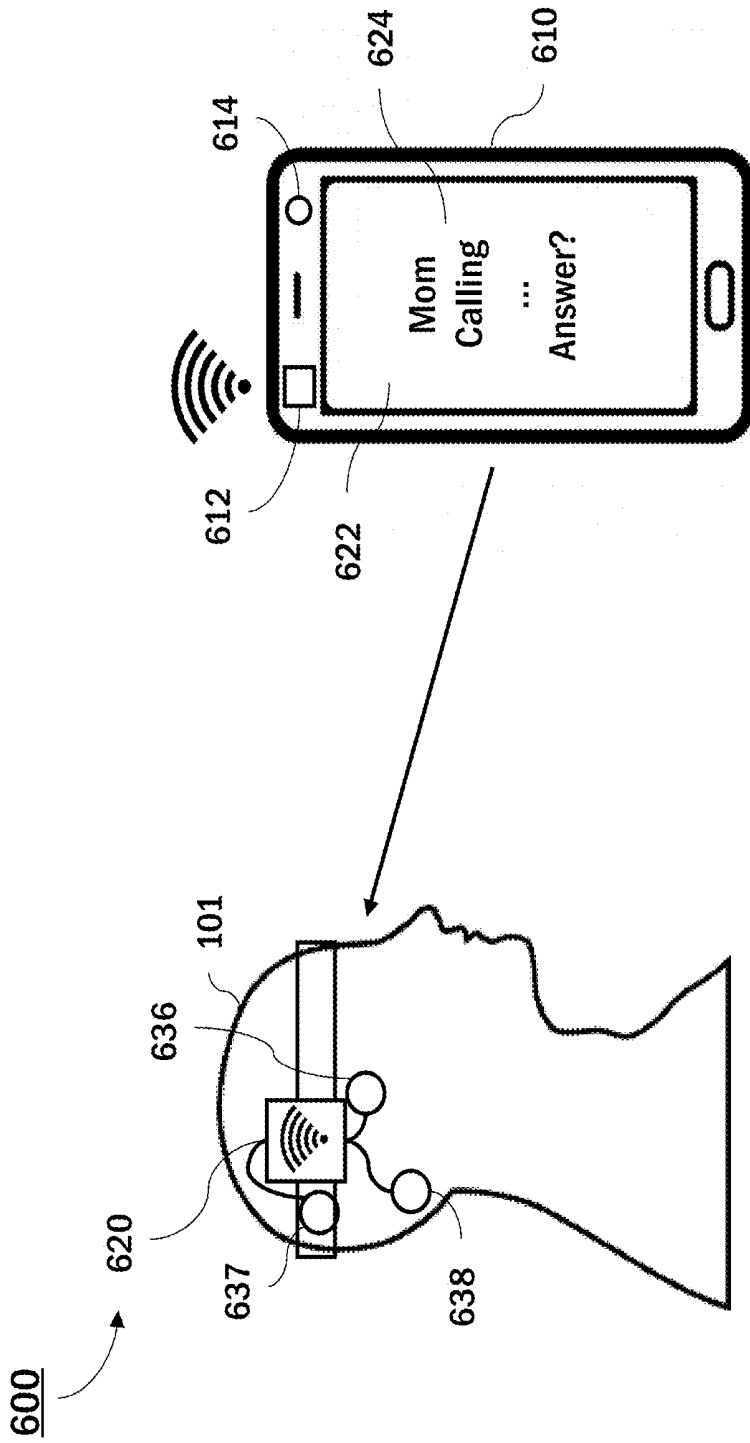

FIG. 6

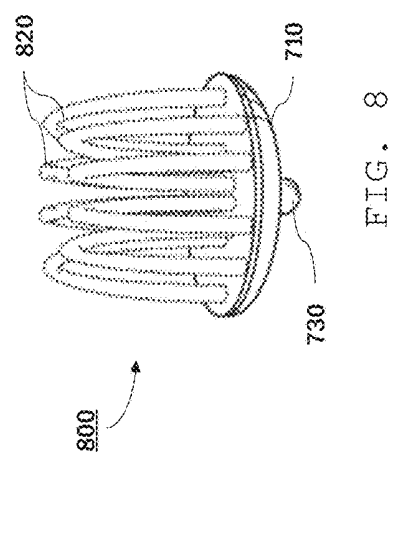
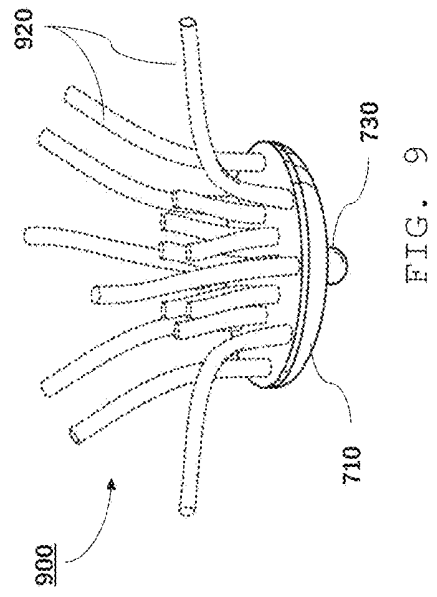
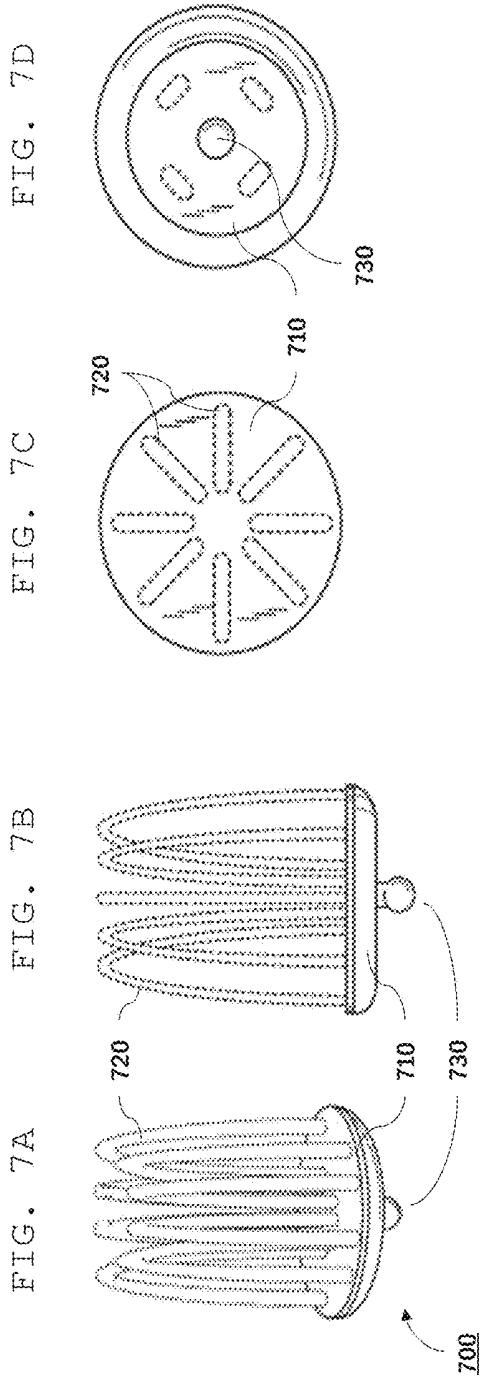

FIG. 7D

FIG. 7C

FIG. 7B

FIG. 7A

FIG. 9

FIG. 8

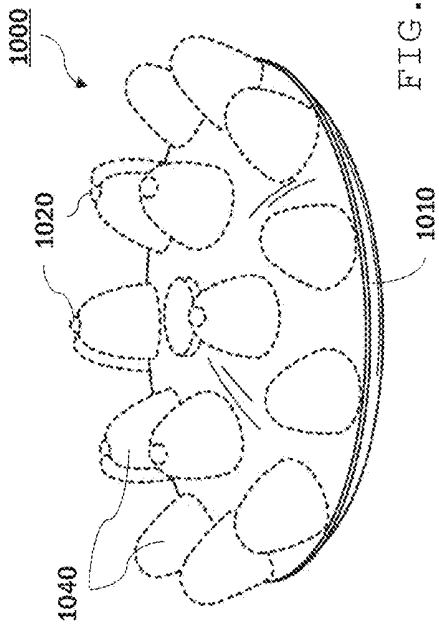

FIG. 10A

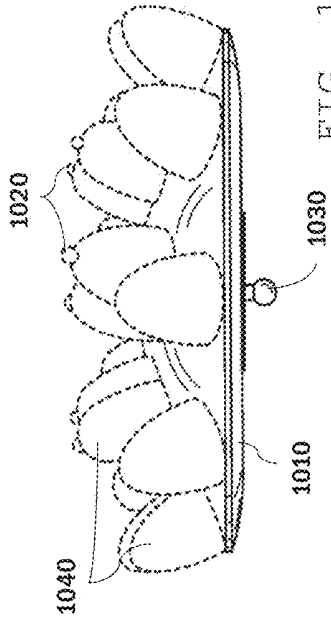

FIG. 10B

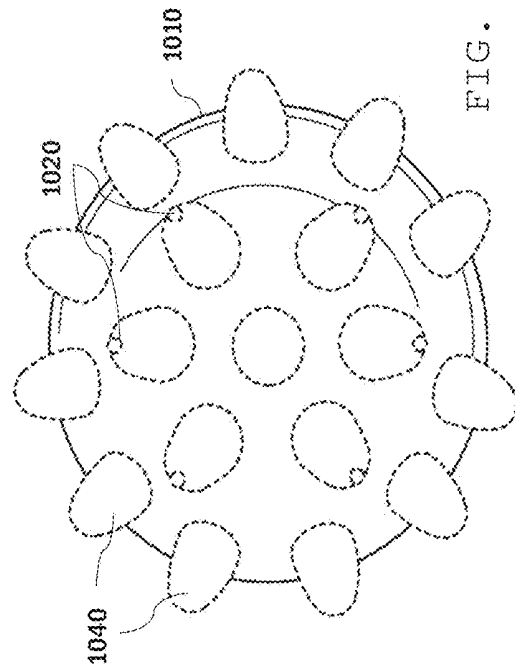

FIG. 10C

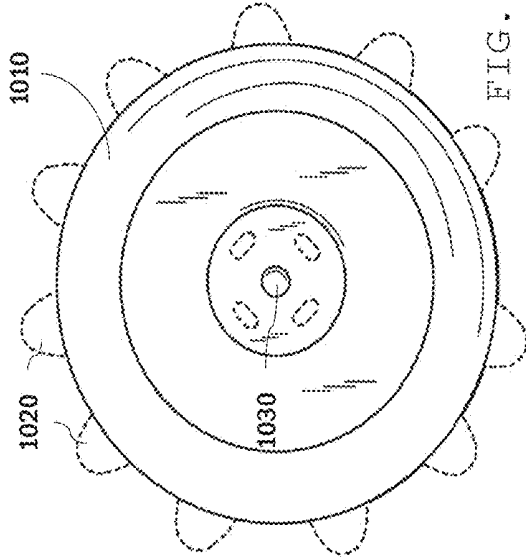

FIG. 10D

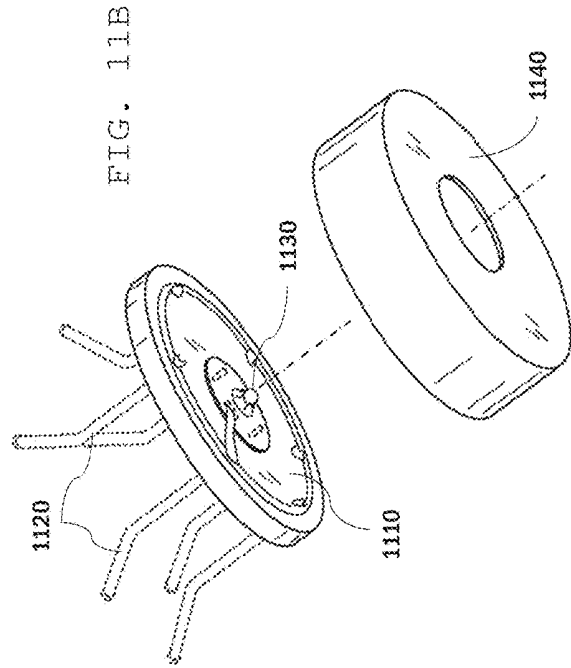

FIG. 11A

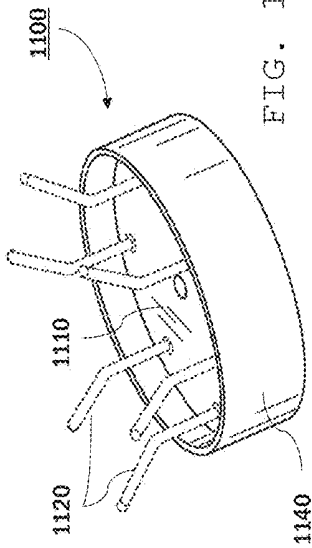

FIG. 11B

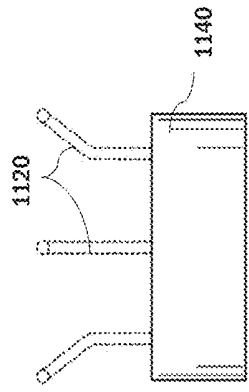

FIG. 11C

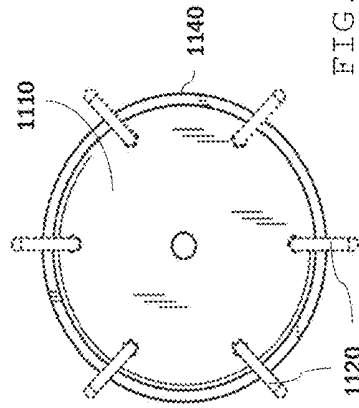

FIG. 11D

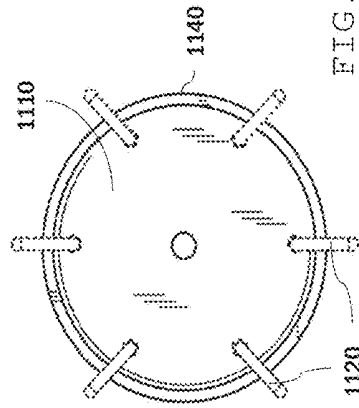

FIG. 11E

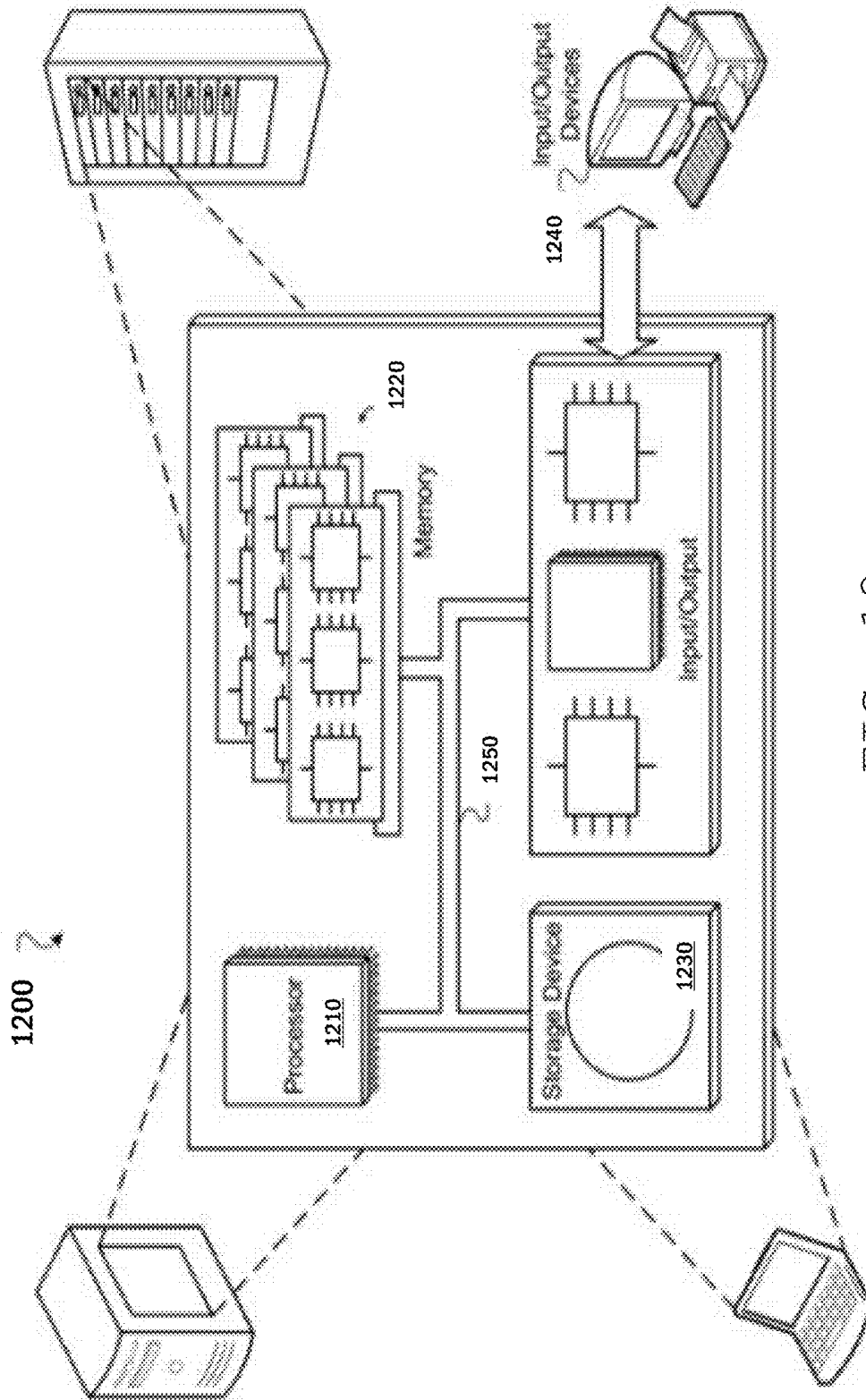

FIG. 12

INTERFACE FOR ELECTROENCEPHALOGRAM FOR COMPUTER CONTROL

FIELD

[0001] This specification relates generally to electroencephalogram (EEG) signal processing and analysis, and more specifically to systems and methods for predictive analysis of EEG signals.

BACKGROUND

[0002] An electroencephalogram (EEG) is a measurement that detects electrical activity in a person's brain. EEG measures the electrical activity of large, synchronously firing populations of neurons in the brain with electrodes placed on the scalp.

[0003] EEG researchers have investigated brain activity using the event-related potential (ERP) technique, in which a large number of experimental trials are time-locked and then averaged together, allowing the investigator to probe sensory, perceptual, and cognitive processing with millisecond precision. However, such EEG experiments are typically administered in a laboratory environment by one or more trained technicians. EEG administration often involves careful application of multiple sensor electrodes to a person's scalp, acquiring EEG signals using specialized and complex equipment, and offline EEG signal analysis by a trained individual.

SUMMARY

[0004] This specification describes technologies for EEG signal processing in general, and specifically to systems and methods for prompting, processing, and analyzing EEG signals using machine learning techniques. These technologies generally involve an EEG system that is portable with easy to apply sensors. The system is able to prompt, acquire, and process EEG signals in real time, and can determine actions or behaviors desired by a user based on the EEG signals.

[0005] This specification generally describes an EEG system, integrated with machine learning models, that provides cleaned EEG signals and can implement actions chosen by a user based on the EEG signals alone. For example, a user may be looking at a menu and create brain signals to select a menu item using only brain activity. The EEG system can receive EEG signals from the user's brain and determine which menu item the user intends to select based on the EEG signals. The EEG system uses the EEG signals as input to machine learning models and generates output including EEG signals and the user's selection.

[0006] In general, in a first aspect, the invention features a method for analyzing electroencephalogram (EEG) signals and a bioamplifier for analyzing EEG signals.

[0007] Other embodiments of this aspect include corresponding computer systems, apparatus, and computer programs recorded on one or more computer storage devices, each configured to perform the actions of the methods. For a system of one or more computers to be configured to perform particular operations or actions means that the system has installed on it software, firmware, hardware, or a combination of them that in operation cause the system to perform the operations or actions. For one or more computer programs to be configured to perform particular operations

or actions means that the one or more programs include instructions that, when executed by data processing apparatus, cause the apparatus to perform the operations or actions.

[0008] The foregoing and other embodiments can each optionally include one or more of the following features, alone or in combination. In particular, one embodiment includes all the following features in combination.

[0009] An example method for analyzing electroencephalogram (EEG) signals includes: presenting information associated with two or more options to a user; receiving EEG signals from a sensor coupled to the user contemporaneously to the user receiving the information associated with the two or more options; processing the EEG signals in real time to determine which one of the options was selected by the user; and in response to determining which one of the options was selected by the user, selecting an action from one or more possible actions associated with the information presented to the user; and generating an output associated with the selected action.

[0010] In some embodiments, the generated output may include control signal for an electronic device.

[0011] In some embodiments, the steps of presenting, processing, and generating may be part of a closed-loop feedback system through which the user controls the electronic device. The information may be presented to the user using the electronic device. The electronic device may be selected from the group consisting of a networked device, a personal computer, a tablet computer, a mobile phone, and a wearable computer.

[0012] In some embodiments, information may be presented visibly or audibly to the user. The information may be presented based on an object detected in the user's environment. The object may be detected based using machine vision.

[0013] In some embodiments, processing the EEG signals may include cleaning the EEG signals in real time. Cleaning the EEG signals may include increasing a signal-to-noise ratio of the EEG signals. The EEG signals may be cleaned according to a machine learning model. The machine learning model may be a neural network or another artificial intelligence architecture. Processing the EEG signals may include performing mathematical transformations on the EEG signals in real time after cleaning the EEG signals to determine which of the options was selected by the user. The mathematical transformations may be performed according to a machine learning model. The machine learning model may be a neural network or other artificial intelligence architecture. The machine learning model may map a time series of values corresponding to an amplitude or change in amplitude of the EEG signal to an output variable corresponding to one of the options based on a mapping function. The mapping function may be determined by training the machine learning model.

[0014] In some embodiments, generating an output may include presenting the user with additional information associated with the selected action. The additional information associated with the selected action may be information associated with two or more further options.

[0015] In other embodiments, generating an output may include sending instructions over a network in communication with a processor used to process the EEG signals.

[0016] An example electroencephalogram system includes: a plurality of sensors for detecting electrical activ-

ity in a user's brain; a user interface configured to present information to the user; and a data processing apparatus in communication with the plurality of sensors and the user interface, the data processing apparatus comprising at least one computer processor and being programmed, during operation of the EEG system, to cause the EEG system to: prompt the user to select from two or more options; receive EEG signals from the plurality of sensors contemporaneously to the user receiving the information about the options; process the EEG signals in real time to determine which one of the options was selected by the user; in response to determining which one of the options was selected by the user, select an action from one or more possible actions associated with the information presented to the user; and generate an output associated with the selected action.

[0017] In some embodiments, the user interface is a component of an electronic device and the plurality of sensors and data processing apparatus are part of a closed-loop feedback system through which the user controls the electronic device. The electronic device may be selected from the group consisting of a networked device, a personal computer, a tablet computer, a mobile phone, and a wearable computer. The user interface may comprise an electronic display. The data processing apparatus may be programmed to process the EEG signals by cleaning the EEG signals in real time.

[0018] In some embodiments, the data processing apparatus may be programmed to process the EEG signals by performing mathematical transformations on the EEG signals in real time after cleaning the EEG signals to determine which one of the options was selected by the user. The mathematical transformations may be performed according to a machine learning model. At least one computer processor may perform both the EEG signal cleaning and the mathematical transformations.

[0019] In some embodiments, a bioamplifier may include the data processing apparatus. The bioamplifier may include an analogue-to-digital converter arranged to receive the EEG signals from the plurality of sensors and convert the EEG signals from analogue signals to digital signals. The bioamplifier may further include an amplifier arranged to receive the EEG signals from the analogue-to-digital converter and amplify the received EEG signals. The bioamplifier may include a housing containing the data processing apparatus and a power source.

[0020] In some embodiments, the user interface may include an electronic display. The user interface may include a camera.

[0021] In some embodiments, the system may include a networked computing device in communication with the user interface. In other embodiments, the system may include a mobile device, wherein the user interface and data processing apparatus are part of the mobile device.

[0022] In some embodiments, the plurality of sensors include an active sensor and a reference sensor. The plurality of sensors may be dry sensors.

[0023] In some embodiments, the system may include a wireless transceiver connecting the plurality of sensors with the data processing apparatus.

[0024] In some embodiments, generating the output includes providing one or more instructions to a computer program on a computer device in communication with the data processing apparatus.

[0025] An example bioamplifier for analyzing electroencephalogram (EEG) signals includes: an input terminal for receiving an EEG signal from a plurality of sensors coupled to a user; an analogue-to-digital converter arranged to receive the EEG signal from the input terminal and convert the EEG signal to a digital EEG signal; a data processing apparatus arranged to receive the digital EEG signal from the analogue-to-digital converter and programmed to process, in real time, the digital EEG signal using a first machine learning model to generate a cleaned EEG signal having a higher signal-to-noise ratio than the digital EEG signal; a power source arranged to provide electrical power to the analogue-to-digital converter and the data processing apparatus; and a housing containing the analogue-to-digital converter, the data processing apparatus, the power source, and a housing containing the analogue-to-digital converter, the data processing apparatus, the power source, and the sensor input.

[0026] In some embodiments, the data processing apparatus may be further programmed to process, in real time, the cleaned EEG signal to determine a selection by the user of one of a plurality of options presented to the user.

[0027] In some embodiments, the data processing apparatus may be programmed to perform mathematical transformations on the cleaned EEG signal using a second machine learning model to determine a selection by the user of one of a plurality of options presented to the user.

[0028] In some embodiments, the data processing apparatus includes a computer processor programmed to implement both the first and second machine learning models.

[0029] In some embodiments, the second machine learning model may be a neural network or other artificial intelligence architecture.

[0030] The data processing apparatus may be programmed to synchronize the analysis with a presentation of the options to the user.

[0031] In some embodiments, the bioamplifier includes an output terminal for connecting the bioamplifier to a user interface and the data processing apparatus is programmed to synchronize the analysis with the presentation of the options to the user via the user interface.

[0032] In some embodiments, the user interface may be a component of an electronic device and the plurality of sensors and data processing apparatus are part of a closed-loop feedback system through which the user controls the electronic device. The electronic device may be selected from the group consisting of a networked device, a personal computer, a tablet computer, a mobile phone, and a wearable computer. The user interface may include an electronic display. The user interface may include a camera.

[0033] In some embodiments, the machine learning model may be a neural network or other artificial intelligence architecture.

[0034] In some embodiments, the bioamplifier may include an amplifier contained in the housing and arranged to receive the digital EEG signal from the analogue-to-digital converter and provide an amplified digital EEG signal to the data processing apparatus for processing.

[0035] In some embodiments, the power source may be a battery. The analogue-to-digital converter may be a 24 bit analogue-to-digital converter. The bioamplifier may have an input impedance of 10 MOhms or more. The input terminal may include a jack for receiving a connector from a lead.

The input terminal may include a wireless transceiver for wirelessly receiving the EEG signal.

[0036] An example method may include: receiving at least one EEG signal from a user via a plurality of sensors coupled to the user; amplifying, using a bioamplifier, the EEG signal from the plurality of sensors to provide an amplified EEG signal; processing, in real time, the amplified signal using a machine learning model that receives the amplified signal as input; and outputting a cleaned signal by the machine learning model, the cleaned signal having a higher signal-to-noise ratio than the at least one EEG signal received from the user.

[0037] In some embodiments, the method may further include processing, in real time, the cleaned EEG signal to determine a selection by the user of one of a plurality of options presented to the user.

[0038] In some embodiments, the method may further include sending a signal to an electronic device based on the selection determined from the cleaned EEG signal.

[0039] Among other advantages, the systems include portable, robust bioamplifiers that can provide real-time analysis of EEG signals under conditions that would typically result in significant signal noise and therefore be unusable or more difficult to use with other systems. For example, the systems can incorporate machine learning models that clean amplified EEG signals in real time to reduce signal noise. The machine learning models can be implemented on the same chip or hardware that performs EEG signal acquisition. The bioamplifiers can also analyze the EEG signals in real-time.

[0040] In some embodiments, the systems can provide real-time EEG analysis facilitating user interaction with a digital environment. For example, EEG systems can incorporate machine learning models that interpret EEG signals associated with information presented to the user by a computer device (e.g., a mobile device or personal computer). Accordingly, a user can use the disclosed systems to interact with a computer device using only their brain activity.

[0041] The details of one or more embodiments of the subject matter of this specification are set forth in the accompanying drawings and the description below. Other features, aspects, and advantages of the subject matter will become apparent from the description, the drawings, and the claims.

BRIEF DESCRIPTION OF THE DRAWINGS

[0042] FIG. 1 is a schematic diagram of an embodiment of an EEG system.

[0043] FIG. 2 is a flowchart showing aspects of the operation of the EEG system shown in FIG. 1.

[0044] FIG. 3 is a plot comparing two EEG signals for analysis using the system in FIG. 1.

[0045] FIG. 4 is a flowchart showing other aspects of the operation of the EEG system shown in FIG. 1.

[0046] FIG. 5 is a schematic diagram of an embodiment of an EEG system that features a head-mounted camera.

[0047] FIG. 6 is a schematic diagram of another embodiment of an EEG system that features a mobile phone and a wireless connection to the system's sensor electrodes.

[0048] FIG. 7A is a perspective view of an embodiment of a sensor electrode including multiple wire loops.

[0049] FIG. 7B is a side view of the sensor electrode shown in FIG. 7A.

[0050] FIG. 7C is a top view of the sensor electrode shown in FIG. 7A.

[0051] FIG. 7D is a bottom view of the sensor electrode shown in FIG. 7A.

[0052] FIG. 8 is a perspective view of another embodiment of a sensor electrode including multiple wire loops.

[0053] FIG. 9 is a perspective view of an embodiment of a sensor electrode that includes wires of differing lengths.

[0054] FIG. 10A is a perspective view of an embodiment of a sensor electrode that includes multiple protuberances.

[0055] FIG. 10B is a side view of the sensor electrode shown in FIG. 10A.

[0056] FIG. 10C is a top view of the sensor electrode shown in FIG. 10A.

[0057] FIG. 10D is a bottom view of the sensor electrode shown in FIG. 10A.

[0058] FIG. 11A is a perspective view of an embodiment of a sensor electrode that includes a protective collar.

[0059] FIG. 11B is an exploded perspective view of the sensor electrode shown in FIG. 11A.

[0060] FIG. 11C is a side view of the sensor electrode shown in FIG. 11A.

[0061] FIG. 11D is a bottom view of the sensor electrode shown in FIG. 11A.

[0062] FIG. 11E is a top view of the sensor electrode shown in FIG. 11A.

[0063] FIG. 12 is a schematic diagram of a data processing apparatus that can be incorporated into an EEG system.

[0064] Like reference numbers and designations in the various drawings indicate like elements.

DETAILED DESCRIPTION

[0065] Referring to FIG. 1, an EEG system 100 features a portable bioamplifier 110 that collects and analyzes EEG signals from a user 101 using electrode sensors 136, 137, and 138 attached to user 101's scalp. Bioamplifier 110 is in communication with a personal computer 140 which displays information 142—in this instance an image of an ice cream cone—to user 101. Bioamplifier 110 synchronously collects EEG signals from user 101 while displaying information 142 and analyzes the EEG signals, interpreting in real time user 101's brain activity responsive to viewing the information.

[0066] In certain embodiments, bioamplifier 110 is a high-impedance, low-gain amplifier with a high dynamic range. The bioamplifier impedance may be, for example, higher than 10 megaohms (e.g., 12 M Ω or more, 15 M Ω or more, 20 M Ω or more) with a maximum gain of 24 \times amplification. The dynamic range of bioamplifier 110 should be sufficient to acquire the entire voltage range of typical EEG signals (e.g., 0.1 to 200 μ V over frequency ranges of 1 to 100 Hz). As a portable unit, bioamplifier 110 is housed within a compact, robust casing, providing a package that can be readily carried by user 101, sufficiently robust to remain functional in non-laboratory settings.

[0067] Electrode sensors 136, 137, and 138 may be dry sensors or may be placed in contact with the user's scalp using a gel. The sensors can be secured in place using, for example, adhesive tape, a headband, or some other headwear. One of sensors 136, 137, and 138 is an active sensor. Generally, the active sensor's location on the user's scalp depends on the location of brain activity of interest. In some implementations, the active sensor is placed at the back of the user's head, at or close to the user's inion. Another one

of the sensors is a reference sensor. The EEG signal typically corresponds to measured electrical potential differences between the active sensor and the reference sensor. The third sensor is a ground sensor. Typically, the ground sensor is used for common mode rejection and can reduce (e.g., prevent) noise due to certain external sources, such as power line noise. In some implementations, the ground and/or reference sensors are located behind the user's ears, on the user's mastoid process.

[0068] Bioamplifier 110 includes jacks 132 and 134 for connecting leads 135 and 143 to the electrode sensors and personal computer 140, respectively. Bioamplifier 110 further includes an analogue-to-digital converter 112, an amplifier 114, and a processing module 120. Although depicted as a single analogue-to-digital converter and a single amplifier, analogue-to-digital converter 112 and amplifier 114 may each have multiple channels, capable of converting and amplifying each EEG signal separately. A power source 130 (e.g., a battery, a solar panel, a receiver for wireless power transmission) is also contained in bioamplifier 110 and is electrically connected to ADC 112, amplifier 114, and processing module 120. In general, analogue-to-digital converter 112 and amplifier 114 are selected to yield digital signals of sufficient amplitude to be processed using processing module 120.

[0069] Processing module 120 includes one or more computer processors programmed to analyze and clean amplified EEG signals received from amplifier 114 in real time. The computer processors can include commercially-available processors (e.g., a raspberry pi micro-controller) and/or custom components. In some embodiments, processing module 120 includes one or more processors custom designed for neural network computations (e.g., Tensor Processing Unit from Google or Intel Nervanna NNP from Intel Corp.). Generally, processing module 120 should include sufficient computing power to enable real time cleaning and analysis of the EEG signals.

[0070] The components of processing module 120 are selected and programmed to include two machine learning (ML) models: a ML cleaning model 122 and a ML two-choice decision model 124. ML cleaning model 122 receives raw EEG signals from amplifier 114 and, by application of a machine learning algorithm, cleans the signals to reduce noise. Thus, ML cleaning model 122 outputs cleaned EEG signals that have a reduced signal-to-noise ratio as compared with the input signals. Cleaning the EEG signal includes various operations that improve the usability of the signal for subsequent analysis, e.g., by reducing noise in the EEG signal. For example, cleaning the EEG signal can include filtering the signal by applying a transfer function to input data, e.g., to attenuate some frequencies in the data and leave others behind. Other signal cleaning operations are also possible. For example, signals can be cleaned using a neural network. Cleaning can also include operations to improve signal quality besides removal of undesirable frequencies. For instance, cleaning can include removing blinks, which digital filtering alone does not do.

[0071] Referring to FIG. 2, the process of digitizing, amplifying, and cleaning an EEG signal is shown in a flowchart 200. An EEG signal, e.g., a time-varying voltage differential between a voltage measured using an active sensor and a reference sensor, is received by a bioamplifier (e.g., bioamplifier 110) from the sensors attached to the user's scalp (step 210). The frequency at which the sensor

voltage is sampled should be sufficient to capture voltage variations indicative of the brain activity of interest (e.g., between 0.1 and 10 Hz, at 10 Hz or more, at 50 Hz or more, at 100 Hz or more). An ADC (e.g., ADC 112) converts the signal from an analogue signal to a digital signal (step 220) and sends the digital signal to an amplifier (e.g., amplifier 114). The digital EEG signal is then amplified (e.g., by amplifier 114) (step 230), and the amplified signal sent to a processor (e.g., processing module 120). The processor (e.g., processing module 120), in real time, cleans the amplified signal using a machine learning model (e.g., ML model 122), thereby generating a filtered (e.g., cleaned) signal (step 240), and outputs the cleaned signal having increased signal-to-noise compared to an uncleaned EEG signal (step 250).

[0072] In general, any of a variety of ML models suitable for signal processing can be used to clean the amplified EEG signal. In many cases, the ML model is a neural network, which is an ML model that employs one or more layers of nonlinear units to predict an output for a received input. Some neural networks are deep neural networks that include two or more hidden layers in addition to the input and output layers. The output of each hidden layer is used as input to another layer in the network, i.e., another hidden layer, the output layer, or both. Some layers of the neural network generate an output from a received input, while some layers do not (remain "hidden"). The network may be recurrent or feedforward. It may have a single output or an ensemble of outputs; it may be an ensemble of architectures with a single output or a single architecture with a single output.

[0073] A neural network for a machine learning model (e.g., ML model 122) can be trained on EEG-specific data in order to distinguish between actual, usable data and noise. The ML model can be trained to classify artifacts in the EEG and to deal with EEG segments that have different types of noise in different ways. For example, if the network recognizes a vertical eye movement (a blink) it could attempt to remove the blink using a different approach than it would use if it recognized a horizontal eye movement. The ML model can be trained to clean data to an arbitrary level of precision—that is, it can clean up the raw data a little bit or a lot but there is no theoretical limit as to how closely the ML model can reproduce the type of clean data it was trained on. The level of cleaning that the ML model does is dependent only on time and the architecture of the model, that is, there is no theoretical maximum amount of possible cleaning.

[0074] EEG signals, even under controlled conditions, may contain significant noise, e.g., due to biological and/or electrical sources. The propensity for noise is further increased outside of a well-controlled laboratory environment. Accordingly, ML-based noise reduction may be particularly beneficial in providing usable EEG data in real time in real world (i.e., outside of a well-controlled environment) conditions.

[0075] As noted previously, a processor (e.g., processing module 120) includes a machine learning two-choice decision model (e.g., ML two-choice decision model 124) for analyzing cleaned EEG signals that output from a machine learning cleaning model (e.g., ML cleaning model 122). The two-choice model interprets a response of a user (e.g., user 101) to information (e.g., information 142) presented via a computer (e.g., computer 140). A user's response may be a selection of one choice among a finite set, e.g., two or more,

of choices presented to the user. The two-choice model associates one of two binaries with information (e.g., information 142), such as interest (e.g., acceptance of an option) of the user in the information, or disinterest (e.g., rejection of an option).

[0076] In general, various parameters of the cleaned EEG signal can be used to determine the user's response (e.g., the user's choice selection). Often, these parameters include the amplitude of the response amplitude over a relevant time period (e.g., within about 500 ms of being presented with information 142). This is illustrated in the plot shown in FIG. 3, for example, which compares two EEG signals corresponding to interest (trace 310) and disinterest (trace 320) in information presented to the user. After an initial latency of approximately 50 ms, trace 310 has a significantly larger amplitude than trace 320. A machine learning model (e.g., ML model 124) associates the higher amplitude with the user's interest, and returns this information to a computer (e.g., computer 140).

[0077] This process is illustrated by flowchart 400 shown in FIG. 4. In step 410, a system (e.g., system 100) presents information (e.g., information 142) to a user (e.g., user 101) via a user interface, for example, provided by a personal computer (e.g., personal computer 140). The system (e.g., system 100) receives EEG signals from the system's sensors placed on (e.g., removably attached or otherwise coupled to) the user's scalp (step 420). The system (e.g., system 100) amplifies and cleans the signals as described above using an amplifier and a machine learning model (e.g., ML model 122). The system (e.g., system 100) then provides the cleaned EEG signals as input to a machine learning model (e.g., ML model 124), which generates an output from the input indicating the user's response to information (e.g., information 142) or selection of an option (step 430). The system provides input and generates output in real-time to feed a closed loop. In embodiments, signal analysis involves correlating the cleaned EEG signal to the presentation of information to the user (e.g., by matching a time-stamp associated with signal to the time of presentation) and observing the time-varying amplitude of the signal associated with the user's brain activity responsive to the information. The system can decompose the signal into a time series of signal amplitude and/or change in signal amplitude and perform mathematical operations on the time series to determine the user's intent. For example, the mathematical operations can associate a change in signal amplitude above a certain threshold and within a certain time (e.g., with 50 ms or less) of presenting the user with the information with a particular intention (e.g., an affirmative response) and a change in signal amplitude below the threshold with the opposite intention (e.g., a negative response). The threshold amplitude and/or response time can be determined by training the ML model.

[0078] The system (e.g., system 100) then outputs results indicative of the user's response to the information (step 440). The user's response to the information may be a selection among multiple choices. For example, the user may be presented with a menu of options to order for dinner. The user may respond with EEG signals that the system can process to determine the user's dinner choice. The system can then output the selected dinner choice of the user.

[0079] In some embodiments, a bioamplifier (e.g., bioamplifier 110) can relay the results of two-choice decision model analysis to another device (e.g., personal computer

140), which may take certain actions depending on the results. Examples are described below.

[0080] In some embodiments, the cleaning and analysis processing occurs on the same processing module (e.g., using the same processor, e.g., the same processor core), the system does not need to send the signals across a network and therefore does not incur added data processing latency of network connections or bandwidth restrictions. The system executes calculations as soon as the amplified signal is ready for processing, providing a very low lag response to the user.

[0081] Moreover, the system can operate as a closed-loop system. For example, the bioamplifier and other device (e.g., personal computer 140) operate using feedback in which the system regulates presentation of information to the user by the device based on the analysis of the user's prior or contemporaneous EEG signals. For instance, the device can present the user with a choice between two or more different options and, based on the user's selection as interpreted from the associated EEG signals, present subsequent choices to the user associated with the user's prior choice.

[0082] In some embodiments, the system (e.g., system 100) can use the received EEG signals from the user's brain activity to determine a user's selection among the finite set of possibilities and subsequently perform an action based on the user's selection without requiring the user to provide more input than the brain activity signals. In order to determine the correct action to execute, a machine learning model (e.g., ML model 124) takes EEG signals as input and classifies the EEG signals according to the user's intended action. This is achieved by processing the cleaned EEG input to the machine learning model (e.g., ML model 124) through the hidden layers of the model and performing machine classification. This may involve, for example, feature extraction or successive nonlinear recordings.

[0083] Essentially, the cleaned data is presented to the machine learning model (e.g., ML model 124) and then the machine learning model (e.g., ML model 124) performs a number of mathematical transformations of the cleaned data in order to produce an output that reflects the intention of the user as encoded in the EEG data. The ML model is able to do this because it has been extensively trained, prior to interaction with the user, on what types of EEG signals correspond to what types of responses (e.g., selections by the user).

[0084] In general, a variety of neural networks can be used to analyze and classify the data. For example, the neural network can be a convolutional neural network model, a support vector machine, or a generative adversarial model. In some implementations, lower dimensional models, e.g., a low featural multilayer perceptron or divergent autoencoder can be implemented. The minimum number of features that can be used to achieve acceptable accuracy in decoding the user's intention is preferred for computational simplicity. The optimized models may be trained or simulated in constrained computing environments in order to optimize for speed, power, or interpretability. Three primary features of optimization are 1) the number of features extracted (as described above), 2) the "depth" (number of hidden layers) of the model, and 3) whether the model implements recurrence. These features are balanced in order to achieve the highest possible accuracy while still allowing the system to operate in near real time on the embedded hardware.

[0085] In some embodiments, the machine learning model (e.g., ML model 124) uses sub-selection in which the model only compares the current user's brain activity with other user samples that are most similar to that of the user in order to determine the user's selection. Similarity to other users can be operationalized with standard techniques such as waveform convolution and normalized cross correlation. Alternatively, the machine learning model (e.g., ML model 124) compares the user's brain activity to that of all brain activity present in a large dataset. The dataset may contain brain activity samples from one or more other users. Samples for comparison are drawn either from 1) a data system's internal user data or 2) data collected from external users who have opted-in to having their data be included in the comparison database. All samples are anonymized and are non-identifiable.

[0086] To train the machine learning model (e.g., ML model 124), a system (e.g., system 100) can present a user with a choice problem, e.g., a two-choice problem, using a display on a personal computer (e.g., computer 140) or some other interaction element. In some implementations, the system (e.g., system 100) provides the user with one object at a time, e.g., for 500 milliseconds, with random jitter, e.g., between 16 and 64 milliseconds, added between objects. Each image shown to the user is either an image of a first type of object or an image of a second type of object. Prior to displaying any images, the user is told to pay particular attention to the first type of object, e.g., by counting or some other means. While the system (e.g., system 100) is presenting images to the user, it differentiates EEG signals between when the user is paying particular attention to images of the first type of object and when the user is not paying as close of attention to images of the second type of object.

[0087] For example, the system (e.g., system 100) presents the user with sequence of images showing one of two different objects (e.g., a rabbit or a squirrel). Prior to displaying images, the user is told to pay particular attention to images of squirrels only, and to count the squirrels. As each image displays, the system (e.g., system 100) records the user's brain activity and determines a difference between when the user views an image of a rabbit and when the user views an image of a squirrel. This difference is attainable because 1) the squirrels are task-relevant (to the task of counting squirrels) and the rabbits are not and 2) the squirrel-counting task requires an update of working memory (i.e., the number of squirrels that have been viewed) each time a squirrel appears. These cognitive processes are reflected in relatively large signals measurable by the EEG system and separable by the ML model.

[0088] In some embodiments, the machine learning model (e.g., ML model 124) can be trained using equal numbers of objects so that the model does not learn the true population frequency distribution of the objects in the user's world, which may impair the model's ability to distinguish between the user's choices. For example, the system may be trained with equal numbers of squirrels and rabbits, though most users encounter squirrels more often than rabbits.

[0089] After collecting samples from the user, the system (e.g., system 100) classifies the user's EEG signals to distinguish between EEG signals elicited when the user is focused on an image (e.g., views the squirrel in the example above) and when the user is not (e.g., the rabbit). This is accomplished by the machine learning model (e.g., ML model 124). Prior to being passed to the ML system, the

signals may be pre-processed, such as by boxcar filtering, range-normalization, or length normalization. The pre-processed signals are then passed to the machine learning model (e.g., ML system 124) for classification. The classification may be implemented in either a single-model fashion (i.e., classification is done by a single model) or in an ensemble-model fashion (i.e., a number of different types of models all make a classification and then the overall choice is made by a vote). In some implementations, the user samples can be added to the dataset in a database accessible to the system (e.g., system 100) and used to train subsequent neural network models.

[0090] Once the model is trained broadly across multiple functional objects, tasks, and people, the system can use the ML model on any person for any decision task without further training. The more similar the new decision task is to the trained task, the more effective this transfer will be.

[0091] ML models can be trained on various characteristics of the user. For example, in some implementations, models may be trained on a specific age group, e.g., over 40 or under 20. The model may take into account a user's age and choose user samples in the same age range or choose from a subset of user samples in the database. As described above, the database will consist of both internal data and data from external users who have opted-in to their data being included in the comparison database. All samples are anonymized and non-identifiable. Individuals will have the option to include not only their EEG data, but other demographic data such as age and gender. System 100 can then use the trained model in real-life scenarios to distinguish between a selection event by the user and rejection. In general, an EEG system (e.g., EEG system 100) can present a user (e.g., user 101) with choices among a finite set, e.g., two or more, of possibilities, determine the choice that the user (e.g., user 101) has made based on EEG signals from brain activity, and then perform further actions based on the user's choice. As a result, the user (e.g., user 101) can cause the system (e.g., system 100) to perform certain actions without any physical action beyond having the user view the choices on a display and generate brain activity from a selection of the viewed choices.

[0092] For example, the user (e.g., user 101) can choose a contact from a list of multiple contacts and place a phone call the chosen contact using only the user's brain activity. To perform this activity, the EEG system (e.g., EEG system 100) sequentially presents the user (e.g., user 101) with a list of contacts via a computer (e.g., computer 140) and identifies a selection from the list based on received EEG signals from the user's corresponding brain activity. Next, the system (e.g., system 100) presents the user (e.g., user 101) with options for contacting the selected contact, e.g., call, text, share, or email. Again, the system identifies the user's selection based on received EEG signals corresponding to the user's brain activity representing a selection of an option. The system (e.g., system 100) then performs the call or provides instructions to a telephone to make the call.

[0093] While bioamplifier 110 is interfaced with personal computer 140 in system 100, other configurations are also possible. Referring to FIG. 5, for example, an EEG system 500 includes bioamplifier 110 interfaced with a head-mounted camera system 510 which is arranged to track user 101's field of view. Camera system 510 includes a camera 512 and onboard image processing for analyzing images captured by the camera of user 101's field of view. For

example, EEG system **500** is configured to facilitate user **101**'s interaction with an object **522** associated with a quick response (QR) code **520** (as illustrated) or bar codes, NFC tags, or some other identification feature readily identifiable using machine vision.

[0094] An EEG system (e.g., system **500**) analyzes EEG signals from a user (e.g., user **101**) associated with brain waves responsive to a viewing object (e.g., viewing object **522**) synchronously with reading a QR code (e.g., QR code **520**). The analysis returns one of two binary choices, which the system associates with the viewing object (e.g., object **522**) based on the system viewing the QR code (e.g., QR code **520**).

[0095] While the systems described above both feature a portable bioamplifier (i.e., bioamplifier **110**), that connects with either a computer or other interface, other implementations are also possible. For example, the components of a bioamplifier (e.g., bioamplifier **110**) can be integrated into another device, such as a mobile phone or tablet computer. Moreover, while the foregoing systems includes sensors that are connected to the portable bioamplifier using leads, other connections, e.g., wireless connections, are also possible. Referring to FIG. **6**, for instance, an EEG system **600** includes a mobile phone **610** and a head-mounted sensor system **620**. The cleaning and analysis functions of the components of portable bioamplifier **110**, personal computer **140**, and/or camera system **510** described above are all performed by mobile phone **610** alone, or in conjunction with cloud-based computer processors. Mobile phone **610** includes a wireless transceiver **612**, a display **622**, and a camera **614**.

[0096] Sensor system **610** includes a transceiver unit **620** and sensors **636**, **637**, and **638** connected to the transceiver unit. The sensors measure EEG signals as described above, but the signals are related to receiver **612** using a wireless signal transmission protocol, e.g., Bluetooth, near-field communication (NFC), or some other short-distance protocol.

[0097] During operation, a mobile phone (e.g., mobile phone **610**) displays information (e.g., information **624**) to a user (e.g., user **101**) on a display (e.g., display **622**) and, synchronously, receives and analyzes EEG signals from a transceiver unit (e.g., transceiver unit **620**). Based on the EEG signal analysis, the mobile phone (e.g., mobile phone **610**) can take certain actions related to the displayed information. For instance, the phone can accept or reject phone calls based on the EEG signals, or take some other action.

[0098] Alternatively, or additionally, a user (e.g., user **101**) can use a camera (e.g., camera **614**) to capture information in their environment (e.g., to scan a QR code) while the phone receives and analyzes their associated brain waves.

[0099] In general, the EEG systems described above can use a variety of different sensors to obtain the EEG signals. In some implementations, the sensor electrodes are "dry" sensor which feature one or more electrodes that directly contact the user's scalp without a conductive gel. Dry sensors can be desirable because they are simpler to attach and their removal does not involve the need to clean up excess gel. A sensor generally includes one or more electrodes for contacting the user's scalp.

[0100] Referring to FIGS. **7A-7D**, for example, a sensor **700** includes multiple wire loop electrodes **720** mounted on a base **710**, and a press stud electrode **730** on the opposite side of base **710** from loops electrodes **710**. Wire loop

electrodes **720** are bare electrically-conducting wires that are in electrical contact with metal press stud **730**. During use, a user can position sensor **700** in their hair with the top of wire loop electrodes contacting their scalp. A lead, featuring female press stud fastener, is connected to press stud **730**, connecting sensor **700** to a bioamplifier or transceiver. The multiple loop electrodes provide redundant contact points with the user's scalp, increasing the likelihood that the sensor maintains good electrical contact with the user's scalp.

[0101] As is apparent in FIG. **7C** (top view), sensor electrode **700** includes a total of eight wire loop electrodes arranged symmetrically about an axis. More generally, the number of wire loop electrodes can vary as desired. The length of the wire loop electrodes (from base to tip) can also vary as desired. For instance, a user with long hair may select a sensor with longer wire loops than a user with shorter hair. FIG. **8**, for example, shows another sensor electrode **800** similar to sensor electrode **700** but with shorter wire loop electrodes **820**. In general, the loop electrodes can have a length from about 1 mm to about 15 mm.

[0102] FIG. **9** shows yet a further sensor electrode **900** that includes multiple wire electrodes **920**. Wire electrodes **920** can be sufficiently flexible so that the user can bend them to provide optimal contact with the scalp. Each wire electrode **920** can have the same length, or the lengths of the wires can vary.

[0103] Other dry sensor designs are also possible. For example, referring to FIGS. **10A-10D**, a sensor electrode **1000** features multiple protuberances **1040** supported by a base **1010**. The protuberances are formed from a relatively soft material, such as a rubber. As seen from a top view, as shown in FIG. **10C**, protuberances **1040** are arranged in two concentric rings. The protuberances in the inner ring each include a wire electrode **1020** which protrudes from the tip of the respective protuberance. The protruding wire electrodes can be relatively short, reducing possible user discomfort due to the excessive pressure on the user's scalp.

[0104] Referring to FIGS. **11A-11E**, a further example of a sensor electrode **1100** includes a base **1110**, wire electrodes **1120**, a press stud electrode **1130**, and a protective cap **1140** (e.g., a plastic cap). The cap can reduce the likelihood that the user's hair becomes ensnared in the electrode, e.g., where the electrodes are attached to the base.

[0105] In general, the EEG systems described above can be used to accomplish a variety of computer-based tasks. For example, the disclosed system and techniques can be used to perform tasks commonly performed using a networked computer device (e.g., a mobile phone), such as ordering food, scheduling a flight, interacting with household or personal electronic devices, and/or purchasing a ticket for an event. The system can be used for user interaction with objects that have QR codes, bar codes, NFC tags, or another type of identification feature on them so that a system can detect the object with which the user is interacting and determine tasks associated with the object. These can be objects in a user's home such as a thermostat, television, phone, oven, or other electronic device. By way of example, an automated pet door in the user's house may have an associated QR code. By receiving the QR code from the dog door, the system may determine that the user is interacting with the door with their mobile phone. The system then can present the user with a list of options associated with the pet door on their phone. The system can then collect and analyze

the user's EEG signals to determine what action the user would like the system to perform, in this example, whether or not to lock the pet door. Similarly, a system (e.g., EEG system 100) may use a user's phone or other computing device to notice proximity of a smart device. Proximity can be recognized by wireless or wired connectivity, (e.g., Bluetooth, near field communication, RFID, or GPS). Once proximity is determined, the system can present the user with a choice related the smart device. For example, a user's phone may be able to notice that it is in proximity to a smart thermostat, such as a Nest, a Honeywell Lyric Round, or a Netatmo's thermostat, and then present the user with a choice about whether the user would like the temperature to be warmer or colder. Using the EEG decision making protocol described above, the system could then adjust the temperature in the room on the basis of the user's EEG, without the user having to physically interact with the thermostat. Any other two choice decision that can be made for a smart device (e.g., a smart home device such as an Amazon Alexa, Google Home, or Wemo plug device) could be implemented in the same way—for example turning a smart light on or off, turning the volume of a smart speaker up or down, or making a decision to buy or not to buy what is in a digital shopping cart.

[0106] Embodiments of the subject matter and the functional operations described in this specification can be implemented in digital electronic circuitry, in tangibly-embodied computer software or firmware, in computer hardware, including the structures disclosed in this specification and their structural equivalents, or in combinations of one or more of them. Embodiments of the subject matter described in this specification can be implemented as one or more computer programs, i.e., one or more modules of computer program instructions encoded on a tangible non-transitory storage medium for execution by, or to control the operation of, data processing apparatus. The computer storage medium can be a machine-readable storage device, a machine-readable storage substrate, a random or serial access memory device, or a combination of one or more of them. Alternatively, or in addition, the program instructions can be encoded on an artificially-generated propagated signal, e.g., a machine-generated electrical, optical, or electromagnetic signal, that is generated to encode information for transmission to suitable receiver apparatus for execution by a data processing apparatus.

[0107] The term "data processing apparatus" refers to data processing hardware and encompasses all kinds of apparatus, devices, and machines for processing data, including by way of example a programmable processor, a computer, or multiple processors or computers. The apparatus can also be, or further include, special purpose logic circuitry, e.g., an FPGA (field programmable gate array) or an ASIC (application-specific integrated circuit). The apparatus can optionally include, in addition to hardware, code that creates an execution environment for computer programs, e.g., code that constitutes processor firmware, a protocol stack, a database management system, an operating system, or a combination of one or more of them.

[0108] A computer program, which may also be referred to or described as a program, software, a software application, an app, a module, a software module, a script, or code, can be written in any form of programming language, including compiled or interpreted languages, or declarative or procedural languages; and it can be deployed in any form,

including as a stand-alone program or as a module, component, subroutine, or other unit suitable for use in a computing environment. A program may, but need not, correspond to a file in a file system. A program can be stored in a portion of a file that holds other programs or data, e.g., one or more scripts stored in a markup language document, in a single file dedicated to the program in question, or in multiple coordinated files, e.g., files that store one or more modules, sub-programs, or portions of code. A computer program can be deployed to be executed on one computer or on multiple computers that are located at one site or distributed across multiple sites and interconnected by a data communication network.

[0109] The processes and logic flows described in this specification can be performed by one or more programmable computers executing one or more computer programs to perform functions by operating on input data and generating output. The processes and logic flows can also be performed by special purpose logic circuitry, e.g., an FPGA or an ASIC, or by a combination of special purpose logic circuitry and one or more programmed computers.

[0110] Computers suitable for the execution of a computer program can be based on general or special purpose micro-processors or both, or any other kind of central processing unit. Generally, a central processing unit will receive instructions and data from a read-only memory or a random access memory or both. The essential elements of a computer are a central processing unit for performing or executing instructions and one or more memory devices for storing instructions and data. The central processing unit and the memory can be supplemented by, or incorporated in, special purpose logic circuitry. Generally, a computer will also include, or be operatively coupled to receive data from or transfer data to, or both, one or more mass storage devices for storing data, e.g., magnetic, magneto-optical disks, or optical disks. However, a computer need not have such devices. Moreover, a computer can be embedded in another device, e.g., a mobile telephone, a personal digital assistant (PDA), a mobile audio or video player, a game console, a Global Positioning System (GPS) receiver, or a portable storage device, e.g., a universal serial bus (USB) flash drive, to name just a few.

[0111] Computer-readable media suitable for storing computer program instructions and data include all forms of non-volatile memory, media and memory devices, including by way of example semiconductor memory devices, e.g., EPROM, EEPROM, and flash memory devices; magnetic disks, e.g., internal hard disks or removable disks; magneto-optical disks; and CD-ROM and DVD-ROM disks.

[0112] To provide for interaction with a user, embodiments of the subject matter described in this specification can be implemented on a computer having a display device, e.g., a CRT (cathode ray tube) or LCD (liquid crystal display) monitor, for displaying information to the user and a keyboard and a pointing device, e.g., a mouse or a trackball, by which the user can provide input to the computer. Other kinds of devices can be used to provide for interaction with a user as well; for example, feedback provided to the user can be any form of sensory feedback, e.g., visual feedback, auditory feedback, or tactile feedback; and input from the user can be received in any form, including acoustic, speech, or tactile input. In addition, a computer can interact with a user by sending documents to and receiving documents from a device that is used by the

user; for example, by sending web pages to a web browser on a user's device in response to requests received from the web browser. Also, a computer can interact with a user by sending text messages or other forms of message to a personal device, e.g., a smartphone, running a messaging application, and receiving responsive messages from the user in return.

[0113] Embodiments of the subject matter described in this specification can be implemented in a computing system that includes a back-end component, e.g., as a data server, or that includes a middleware component, e.g., an application server, or that includes a front-end component, e.g., a client computer having a graphical user interface, a web browser, or an app through which a user can interact with an implementation of the subject matter described in this specification, or any combination of one or more such back-end, middleware, or front-end components. The components of the system can be interconnected by any form or medium of digital data communication, e.g., a communication network. Examples of communication networks include a local area network (LAN) and a wide area network (WAN), e.g., the Internet.

[0114] The computing system can include clients and servers. A client and server are generally remote from each other and typically interact through a communication network. The relationship of client and server arises by virtue of computer programs running on the respective computers and having a client-server relationship to each other. In some embodiments, a server transmits data, e.g., an HTML page, to a user device, e.g., for purposes of displaying data to and receiving user input from a user interacting with the device, which acts as a client. Data generated at the user device, e.g., a result of the user interaction, can be received at the server from the device.

[0115] An example of one such type of computer is shown in FIG. 12, which shows a schematic diagram of a generic computer system 1200. The system 1200 can be used for the operations described in association with any of the computer-implemented methods described previously, according to one implementation. The system 1200 includes a processor 1210, a memory 1220, a storage device 1230, and an input/output device 1240. Each of the components 1210, 1220, 1230, and 1240 are interconnected using a system bus 1250. The processor 1210 is capable of processing instructions for execution within the system 1200. In one implementation, the processor 1210 is a single-threaded processor. In another implementation, the processor 1210 is a multi-threaded processor. The processor 1210 is capable of processing instructions stored in the memory 1220 or on the storage device 1230 to display graphical information for a user interface on the input/output device 1240.

[0116] The memory 1220 stores information within the system 1200. In one implementation, the memory 1220 is a computer-readable medium. In one implementation, the memory 1220 is a volatile memory unit. In another implementation, the memory 1220 is a non-volatile memory unit.

[0117] The storage device 1230 is capable of providing mass storage for the system 1200. In one implementation, the storage device 1230 is a computer-readable medium. In various different implementations, the storage device 1230 may be a floppy disk device, a hard disk device, an optical disk device, or a tape device.

[0118] The input/output device 1240 provides input/output operations for the system 1200. In one implementation, the

input/output device 1240 includes a keyboard and/or pointing device. In another implementation, the input/output device 1240 includes a display unit for displaying graphical user interfaces.

[0119] While this specification contains many specific implementation details, these should not be construed as limitations on the scope of any invention or on the scope of what may be claimed, but rather as descriptions of features that may be specific to particular embodiments of particular inventions. Certain features that are described in this specification in the context of separate embodiments can also be implemented in combination in a single embodiment. Conversely, various features that are described in the context of a single embodiment can also be implemented in multiple embodiments separately or in any suitable subcombination. Moreover, although features may be described above as acting in certain combinations and even initially be claimed as such, one or more features from a claimed combination can in some cases be excised from the combination, and the claimed combination may be directed to a subcombination or variation of a subcombination.

[0120] Similarly, while operations are depicted in the drawings in a particular order, this should not be understood as requiring that such operations be performed in the particular order shown or in sequential order, or that all illustrated operations be performed, to achieve desirable results. In certain circumstances, multitasking and parallel processing may be advantageous. Moreover, the separation of various system modules and components in the embodiments described above should not be understood as requiring such separation in all embodiments, and it should be understood that the described program components and systems can generally be integrated together in a single software product or packaged into multiple software products.

[0121] As used herein, the term "real-time" refers to transmitting or processing data without intentional delay given the processing limitations of a system, the time required to accurately obtain data and images, and the rate of change of the data and images. In some examples, "real-time" is used to describe concurrently receiving, cleaning, and interpreting EEG signals. Although there may be some actual delays, such delays generally do not prohibit the signals from being cleaned and analyzed within sufficient time such that the data analysis remains relevant to provide decision-making feedback and accomplish computer-based tasks. For example, adjustments to a smart thermostat are calculated based on user EEG signals. Cleaned signals are analyzed to determine the user's desired temperature before enough time has passed to render the EEG signals irrelevant.

[0122] Particular embodiments of the subject matter have been described. Other embodiments are within the scope of the following claims. For example, the actions recited in the claims can be performed in a different order and still achieve desirable results. As one example, the processes depicted in the accompanying figures do not necessarily require the particular order shown, or sequential order, to achieve desirable results. In some cases, multitasking and parallel processing may be advantageous. Wireless or wired connections may be advantageous for different use cases. Miniaturized components may replace existing components. Other data transmission protocols than those listed may be developed and implemented. The nature of the ML systems used for both data cleaning and classification may change.

1. A method for analyzing electroencephalogram (EEG) signals, comprising:

presenting information associated with two or more options to a user;

receiving EEG signals from a sensor coupled to the user contemporaneously to the user receiving the information associated with the two or more options;

processing the EEG signals in real time to determine which one of the options was selected by the user; and in response to determining which one of the options was selected by the user, selecting an action from one or more possible actions associated with the information presented to the user; and

generating an output associated with the selected action.

2. The method of claim 1, wherein the generated output comprises a control signal for an electronic device.

3. The method of claim 2, wherein the presenting, receiving, processing, and generating are part of a closed-loop feedback system through which the user controls the electronic device.

4. The method of claim 2, wherein the information is presented to the user using the electronic device.

5. The method of claim 4, wherein the electronic device is selected from the group consisting of a networked device, a personal computer, a tablet computer, a mobile phone, and a wearable computer.

6. The method of claim 1, wherein presenting the information comprises presenting the information visibly or audibly to the user.

7. The method of claim 1, wherein the information is presented based on an object detected in the user's environment.

8. The method of claim 7, wherein the object is detected based using machine vision.

9. The method of claim 1, wherein processing the EEG signals comprises cleaning the EEG signals in real time.

10. The method of claim 9, wherein cleaning the EEG signals comprises increasing a signal-to-noise ratio of the EEG signals.

11. The method of claim 9, wherein the EEG signals are cleaned according to a machine learning model.

12. The method of claim 11, wherein the machine learning model comprises a neural network or other artificial intelligence architecture.

13. The method of claim 9, wherein processing the EEG signals comprises performing mathematical transformations on the EEG signals in real time after cleaning the EEG signals to determine which one of the options was selected by the user.

14. The method of claim 13, wherein the mathematical transformations are performed according to a machine learning model.

15. The method of claim 14, wherein the machine learning model comprises a neural network or other artificial intelligence architecture.

16. The method of claim 14, wherein the machine learning model maps a time series of values corresponding to an amplitude or change in amplitude of the EEG signal to an output variable corresponding to one of the options based on a mapping function.

17. The method of claim 16, wherein the mapping function is determined by training the machine learning model.

18. The method of claim 1, wherein generating an output comprises presenting the user with additional information associated with the selected action.

19. The method of claim 18, wherein the additional information associated with the selected action is information associated with two or more further options.

20. The method of claim 1, wherein generating an output comprises sending instructions over a network in communication with a processor used to process the EEG signals.

21-41. (canceled)

* * * * *

专利名称(译)	用于计算机控制的脑电图接口		
公开(公告)号	US20190196585A1	公开(公告)日	2019-06-27
申请号	US15/855845	申请日	2017-12-27
[标]申请(专利权)人(译)	X开发有限责任公司		
申请(专利权)人(译)	X开发有限公司		
当前申请(专利权)人(译)	X开发有限公司		
[标]发明人	LASZLO SARAH ANN LEVINE GABRIELLA YEE PHILLIP		
发明人	LASZLO, SARAH ANN LEVINE, GABRIELLA SARGENT, JOSEPH HOLLIS YEE, PHILLIP		
IPC分类号	G06F3/01 A61B5/04 A61B5/0482 A61B5/0484 A61B5/00		
CPC分类号	G06F3/015 A61B5/04012 A61B5/0482 A61B5/04842 A61B5/04845 A61B5/7203 A61B5/7267 G06F3/0482 A61B5/0006 A61B5/0022 A61B5/0478 A61B5/6803 A61B2562/0209 G16H50/70		
其他公开文献	US10671164		
外部链接	Espacenet USPTO		

摘要(译)

公开了一种用于分析脑电图 (EEG) 信号的方法。将与两个或更多选项相关联的信息呈现给用户。来自耦合到用户的传感器的 EEG 信号被同时接收到接收与两个或更多选项相关联的信息的用户。实时处理 EEG 信号以确定用户选择了哪个选项。响应于确定用户选择了哪个选项，选择与呈现给用户的信息相关联的一个或多个可能动作的动作。然后生成与所选动作相关联的输出。

