



US 20190082982A1

(19) **United States**

(12) **Patent Application Publication**

Li et al.

(10) **Pub. No.: US 2019/0082982 A1**

(43) **Pub. Date: Mar. 21, 2019**

(54) **FINGER CUFF UTILIZING MULTIPLE SENSORS FOR BLOOD PRESSURE MEASUREMENT**

Publication Classification

(51) **Int. Cl.**
A61B 5/022 (2006.01)
A61B 5/0225 (2006.01)
A61B 5/00 (2006.01)

(52) **U.S. Cl.**
 CPC *A61B 5/02241* (2013.01); *A61B 5/02141* (2013.01); *A61B 5/6826* (2013.01); *A61B 5/02255* (2013.01)

(71) Applicant: **Edwards Lifesciences Corporation**,
 Irvine, CA (US)

(72) Inventors: **Peiyuan Li**, Amsterdam (NL);
Geertruida Lucretia van der Sar,
 Alphen aan den Rijn (NL); **Ilja Guelen**,
 Ravenstein (NL)

(21) Appl. No.: **16/133,539**

(22) Filed: **Sep. 17, 2018**

Related U.S. Application Data

(60) Provisional application No. 62/561,072, filed on Sep. 20, 2017.

(57) **ABSTRACT**
 Disclosed is a finger cuff that is attachable to a patient's finger to be used in measuring the patient's blood pressure by a blood pressure measurement system utilizing a volume clamp method. The finger cuff comprises a bladder configured to exert pressure on the patient's finger. The finger cuff further comprises a plurality of light emitting diodes (LEDs) and a plurality of photodiodes (PDs) that respectively align with one another to form a plurality of LED-PD pairs. When the finger cuff is placed around the patient's finger, the bladder and the plurality of LED-PD pairs aid in measuring the patient's blood pressure by the blood pressure measurement system utilizing the volume clamp method.

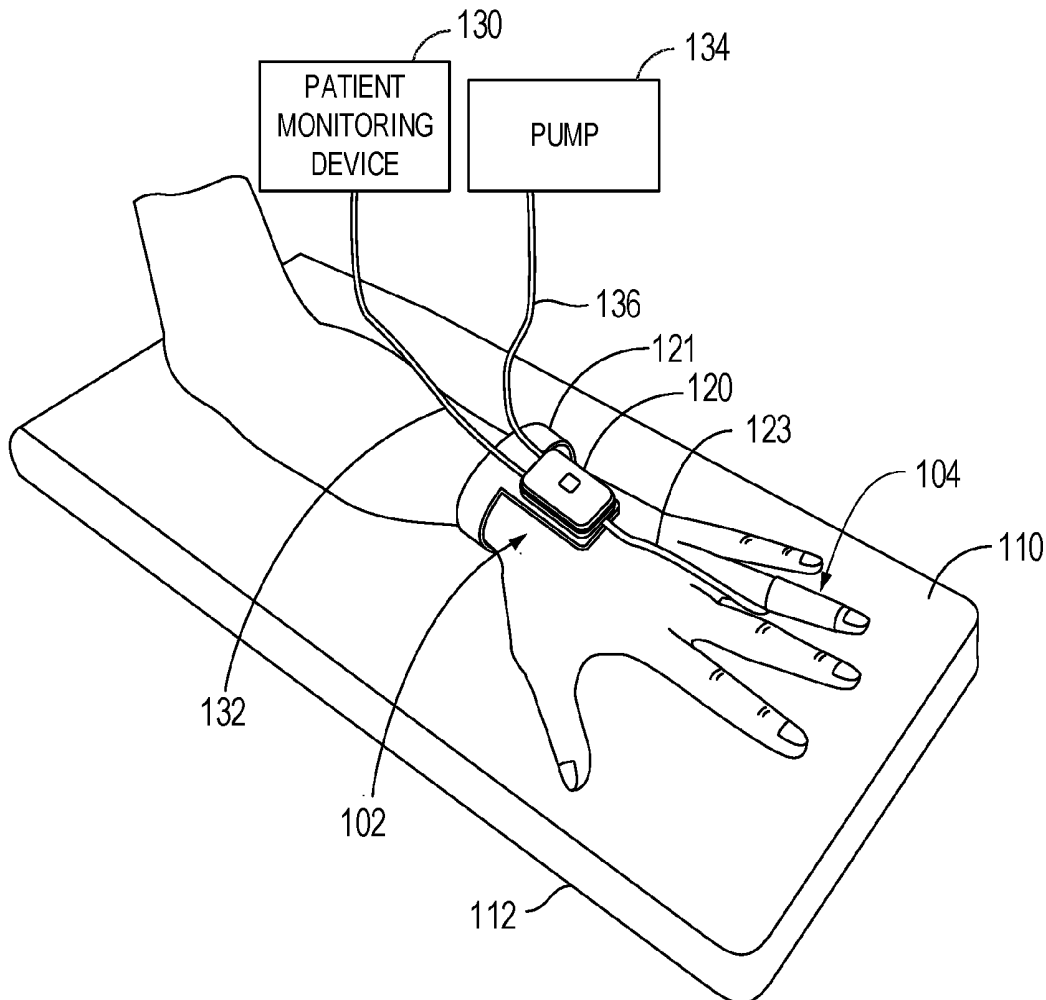

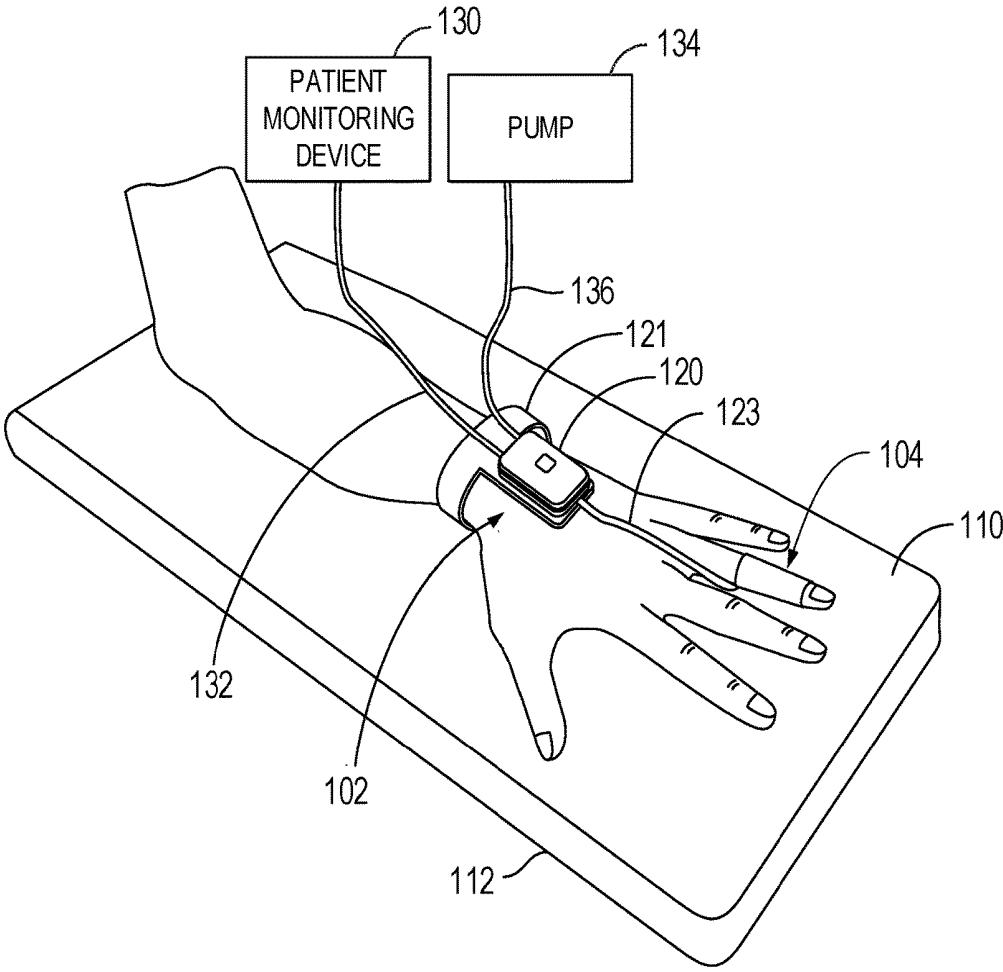

FIG. 1

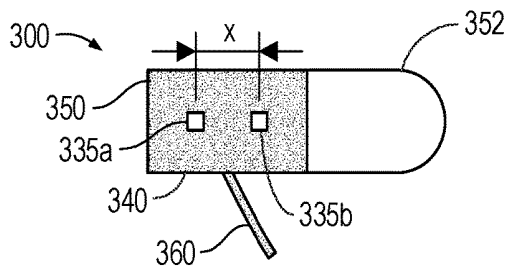

FIG. 2

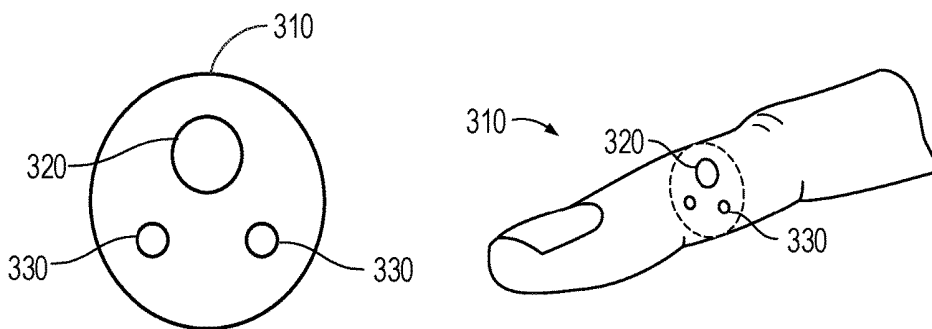

FIG. 3A

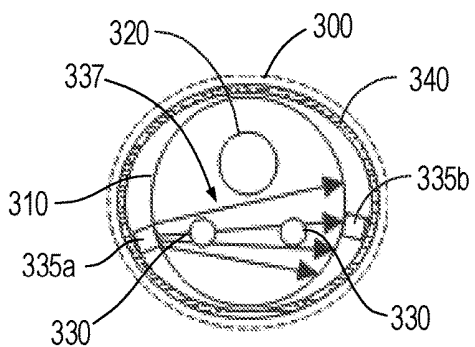

FIG. 3B

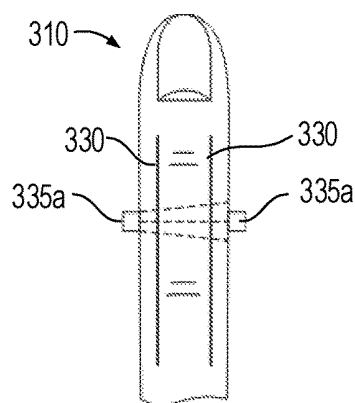

FIG. 3C

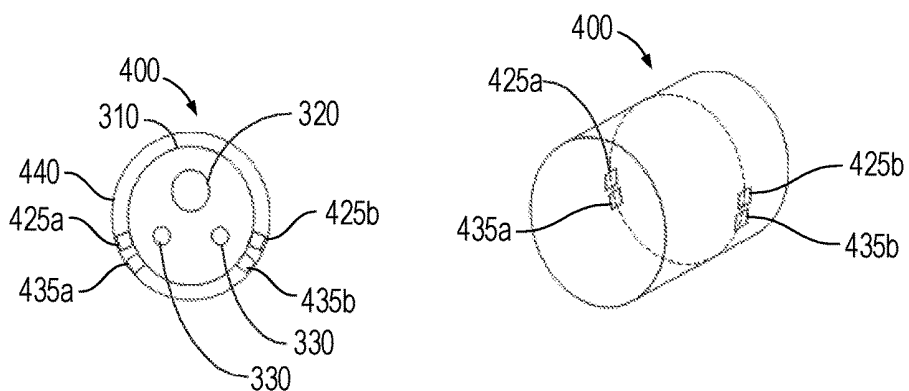

FIG. 4A

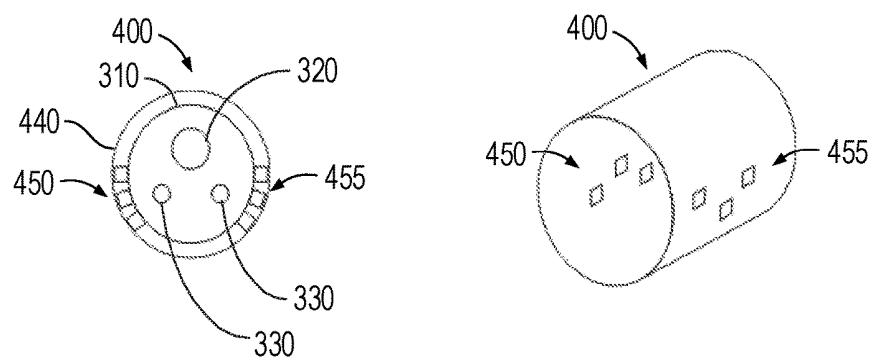

FIG. 4B

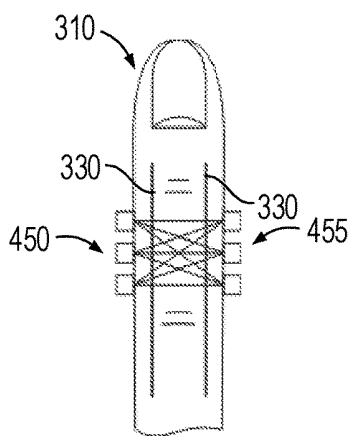

FIG. 4C

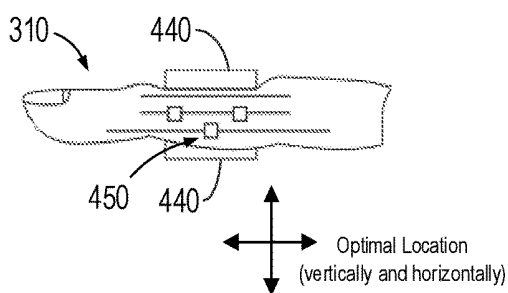

FIG. 4D

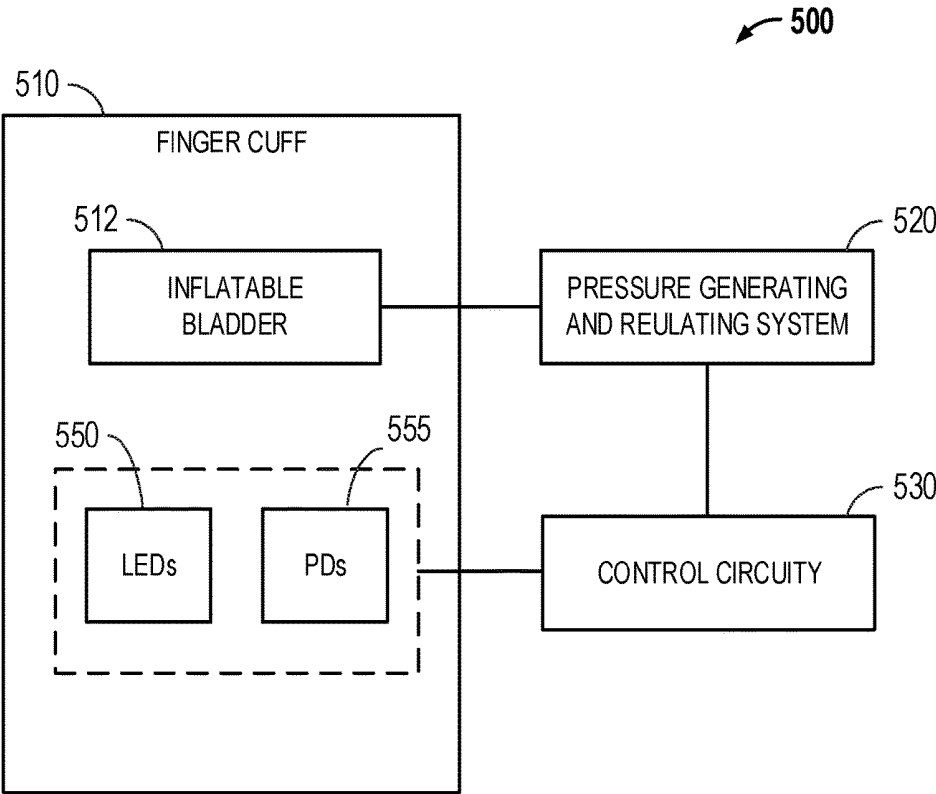

FIG. 5

FINGER CUFF UTILIZING MULTIPLE SENSORS FOR BLOOD PRESSURE MEASUREMENT

CROSS-REFERENCE TO RELATED APPLICATIONS

[0001] This application claims the benefit of U.S. Provisional Application No. 62/561,072, filed Sep. 20, 2017, which is incorporated herein by reference in its entirety.

BACKGROUND

Field

[0002] Embodiments of the invention relate generally to non-invasive blood pressure measurement. More particularly, embodiments of the invention relate to a finger cuff for blood pressure measurement.

Relevant Background

[0003] Volume clamping is a technique for non-invasively measuring blood pressure in which pressure is applied to a patient's finger in such a manner that arterial pressure may be balanced by a time varying pressure to maintain a constant arterial volume. In a properly fitted and calibrated system, the applied time varying pressure is equal to the arterial blood pressure in the finger. The applied time varying pressure may be measured to provide a reading of the patient's arterial blood pressure.

[0004] This may be accomplished by a finger cuff that is arranged or wrapped around a finger of a patient. The finger cuff may include an infrared light source, an infrared sensor, and an inflatable bladder. The infrared light may be sent through the finger in which a finger artery is present. The infrared sensor picks up the infrared light and the amount of infrared light registered by the sensor may be inversely proportional to the artery diameter and indicative of the pressure in the artery.

[0005] In the finger cuff implementation, by inflating the bladder in the finger cuff, a pressure is exerted on the finger artery. If the pressure is high enough, it will compress the artery and the amount of light registered by the sensor will increase. The amount of pressure necessary in the inflatable bladder to compress the artery is dependent on the blood pressure. By controlling the pressure of the inflatable bladder such that the diameter of the finger artery is kept constant, the blood pressure may be monitored in very precise detail as the pressure in the inflatable bladder is directly linked to the blood pressure. In a typical present day finger cuff implementation, a volume clamp system is used with the finger cuff. The volume clamp system typically includes a pressure generating system and a regulating system that includes: a pump, a valve, and a pressure sensor in a closed loop feedback system that are used in the measurement of the arterial volume. To accurately measure blood pressure, the feedback loop provides sufficient pressure generating and releasing capabilities to match the pressure oscillations of the patient's blood pressure.

[0006] Today, finger cuff based blood pressure monitoring devices generally use the same technology (e.g., photoplethysmography or similar technologies) to measure blood pressure. Unfortunately, such finger cuff devices may not be

easily attachable to a patient's finger and may not be that accurate due to the finger cuff's positioning on the patient's finger.

SUMMARY

[0007] Embodiments of the invention may relate to a finger cuff that is attachable to a patient's finger to be used in measuring the patient's blood pressure by a blood pressure measurement system utilizing a volume clamp method. The finger cuff comprises a bladder configured to exert pressure on the patient's finger. The finger cuff further comprises a plurality of light emitting diodes (LEDs) and a plurality of photodiodes (PDs) that respectively align with one another to form a plurality of LED-PD pairs. When the finger cuff is placed around the patient's finger, the bladder and the plurality of LED-PD pairs aid in measuring the patient's blood pressure by the blood pressure measurement system utilizing the volume clamp method.

BRIEF DESCRIPTION OF THE DRAWINGS

[0008] FIG. 1 is a diagram of an example of a blood pressure measurement system according to one embodiment.

[0009] FIG. 2 is a diagram illustrating an example of a conventional finger cuff.

[0010] FIGS. 3A-3C are diagrams illustrating the example of the conventional finger cuff that is arranged around a finger of a patient.

[0011] FIGS. 4A-4D are diagrams illustrating cross-sectional views of examples of finger cuffs according to embodiments of the invention.

[0012] FIG. 5 is a block diagram illustrating an example environment in which embodiments of the invention may be practiced.

DETAILED DESCRIPTION

[0013] With reference to FIG. 1, which illustrates an example of a blood pressure measurement system according to one embodiment, a blood pressure measurement system **102** that includes a finger cuff **104** that may be attached to a patient's finger and a blood pressure measurement controller **120**, which may be attached to the patient's body (e.g., a patient's wrist or hand) is shown.

[0014] The blood pressure measurement system **102** may further be connected to a patient monitoring device **130**, and, in some embodiments, a pump **134**. Further, finger cuff **104** may include a bladder (not shown) and an LED-PD pair (not shown), which are conventional for finger cuffs.

[0015] In one embodiment, the blood pressure measurement system **102** may include a pressure measurement controller **120** that includes: a small internal pump, a small internal valve, a pressure sensor, and control circuitry. In this embodiment, the control circuitry may be configured to: control the pneumatic pressure applied by the internal pump to the bladder of the finger cuff **104** to replicate the patient's blood pressure based upon measuring the pleth signal received from the LED-PD pair of the finger cuff **104**. Further, the control circuitry may be configured to: control the opening of the internal valve to release pneumatic pressure from the bladder; or the internal valve may simply be an orifice that is not controlled. Additionally, the control circuitry may be configured to: measure the patient's blood pressure by monitoring the pressure of the bladder based

upon the input from a pressure sensor, which should be the same as patient's blood pressure, and may display the patient's blood pressure on the patient monitoring device 130.

[0016] In another embodiment, a conventional pressure generating and regulating system may be utilized, in which, a pump 134 is located remotely from the body of the patient. In this embodiment, the blood pressure measurement controller 120 receives pneumatic pressure from remote pump 134 through tube 136 and passes on the pneumatic pressure through tube 123 to the bladder of finger cuff 104. Blood pressure measurement device controller 120 may also control the pneumatic pressure (e.g., utilizing a controllable valve) applied to the finger cuff 104 as well as other functions. In this example, the pneumatic pressure applied by the pump 134 to the bladder of finger cuff 104 to replicate the patient's blood pressure based upon measuring the pleth signal received from the LED-PD pair of the finger cuff 104 (e.g., to keep the pleth signal constant) and measuring the patient's blood pressure by monitoring the pressure of the bladder may be controlled by the blood pressure measurement controller 120 and/or a remote computing device and/or the pump 134 and/or the patient monitoring device 130 to implement the volume clamping method. In some embodiments, a blood pressure measurement controller 120 is not used at all and there is simply a connection from tube 136 from a remote pump 134 including a remote pressure regulatory system to finger cuff 104, and all processing for the pressure generating and regulatory system, data processing, and display is performed by a remote computing device.

[0017] Continuing with this example, as shown in FIG. 1, a patient's hand may be placed on the face 110 of an arm rest 112 for measuring a patient's blood pressure with the blood pressure measurement system 102. The blood pressure measurement controller 120 of the blood pressure measurement system 102 may be coupled to a bladder of the finger cuff 104 in order to provide pneumatic pressure to the bladder for use in blood pressure measurement. Blood pressure measurement controller 120 may be coupled to the patient monitoring device 130 through a power/data cable 132. Also, in one embodiment, as previously described, in a remote implementation, blood pressure measurement controller 120 may be coupled to a remote pump 134 through tube 136 to receive pneumatic pressure for the bladder of the finger cuff 104. The patient monitoring device 130 may be any type of medical electronic device that may read, collect, process, display, etc., physiological readings/data of a patient including blood pressure, as well as any other suitable physiological patient readings. Accordingly, power/data cable 132 may transmit data to and from patient monitoring device 130 and also may provide power from the patient monitoring device 130 to the blood pressure measurement controller 120 and finger cuff 104.

[0018] As can be seen in FIG. 1, in one example, the finger cuff 104 may be attached to a patient's finger and the blood pressure measurement controller 120 may be attached on the patient's hand or wrist with an attachment bracelet 121 that wraps around the patient's wrist or hand. The attachment bracelet 121 may be metal, plastic, Velcro, etc. It should be appreciated that this is just one example of attaching a blood pressure measurement controller 120 and that any suitable way of attaching a blood pressure measurement controller to a patient's body or in close proximity to a patient's body may be utilized and that, in some embodiments, a blood

pressure measurement controller 120 may not be used at all. It should further be appreciated that the finger cuff 104 may be connected to a blood pressure measurement controller described herein, or a pressure generating and regulating system of any other kind, such as a conventional pressure generating and regulating system that is located remotely from the body of the patient (e.g., a pump 134 located remotely from a patient). Any kind of pressure generating and regulating system can be used, including but not limited to the blood pressure measurement controller, and may be described simply as a pressure generating and regulating system that may be used with a finger cuff 104 including an LED-PD pair and a bladder to implement the volume clamping method.

[0019] FIG. 2 is an example of a conventional finger cuff. With reference to FIG. 2, a conventional finger cuff 300 may be formed from a flexible material with a Velcro clamping system. The finger cuff 300 may include a first side 350 and a second side 352. In one embodiment, for attachment purposes to a patient's finger, the second side 352 on the interior may include a first connecting portion (e.g., a Velcro type portion) that connects with a second connecting portion (e.g., a Velcro type portion) on the exterior of the first side 350 of the finger cuff 300. In another embodiment, the first connecting portion may include removable or reusable adhesive material that can be removably attached to the exterior surface of the first side 350 of the finger cuff 300. It should be appreciated that this is just one example of an attachment mechanism and that any suitable type may be utilized (e.g., adhesive, tape, mechanical latching mechanisms, etc.). It should be appreciated that any type of wrappable finger cuff, fixed type of finger cuff, or any type of finger cuff may be used, and this is just one example.

[0020] Further, finger cuff 300 may include a bladder 340 and an LED-PD pair 335a-b mounted on the interior of the finger cuff 300. In one embodiment, the bladder 340 may include a pair of openings that surround the LED-PD pair 335a-b, respectively. The bladder 340 and LED-PD pair 335a-b may be coupled to tube or cable 360 through a connector, which may be attached to finger cuff 300, to provide pneumatic pressure to the bladder 340, and to provide power to and receive data from the LED-PD pair 335a-b. The LED-PD pair 335a-b may be used to perform measurements of a pleth signal to aid in measuring the patient's blood pressure.

[0021] With additional reference to FIGS. 3A-3C, the conventional finger cuff 300 may be wrapped around a patient's finger 310 that may include a finger bone 320 and one or more finger arteries 330. In operation, light (or optical signals) 337 generated by LED 335a may be transmitted or emitted in multiple directions through the finger 310, in which the finger arteries 330 are present. The PD 335b may detect some or all of the light 337 from the LED 335a. The amount of light registered by the PD 335b may be inversely proportional to the artery diameters of the finger arteries 330 and indicative of the pressure of the finger arteries 330.

[0022] For example, in FIGS. 3A-3C, the bladder 340 may be inflated to exert pressure on the finger arteries 330. If the pressure is high enough, for example, it may compress the finger arteries 330, thereby decreasing the diameter of the finger arteries 330 and increasing the amount of light registered by the PD 335b. Conversely, if the pressure is not high enough, it may compress the finger arteries 330 to a lesser extent (or may not compress at all), thereby increasing

the diameter of the finger arteries 330 and decreasing the amount of light registered by the PD 335b. The amount of pressure necessary in the bladder 340 to compress the arteries 330 is dependent on the blood pressure. Therefore, by controlling the pressure of the inflatable bladder 340 such that the diameter of the finger arteries 330 is kept constant, the blood pressure of the patient may be computed and monitored as the pressure in the inflatable bladder 340 is directly linked to the blood pressure. As an example, as part of the volume clamp method, the pneumatic pressure is applied to the bladder 340 of the finger cuff based upon measuring the pleth signal received from the LED-PD pair 335a and 335b of the finger cuff (e.g., to keep the pleth signal constant) so that the pressure applied to the bladder 340 and measured by a pressure sensor should be correlated to the patient's blood pressure.

[0023] With respect to the conventional finger cuff 300, previously described, it is generally available in different sizes (e.g., small, medium, large), and includes differently sized bladders 340 (depending on the size of the finger cuff 300). The distance between the LED 335a and the PD 335b (which may be referred to as "x"), therefore, may vary depending on the size of the finger cuff and bladder to meet the different finger sizes and finger physiology of the patient. In applying the finger cuff 300 on a patient's finger (e.g., finger 310), it is important for a healthcare provider to select a suitable finger cuff size for the patient such that the LED-PD pair 335a-b is properly and effectively positioned on the patient's finger in order to obtain an accurate optical measurement. However, the various sized conventional finger cuffs 300 may not be suitable for the finger sizes and physiology of many patients such that inadequate finger cuff attachments by health care providers may occur. In such circumstances, the LED-PD pair 335a-b may not be properly positioned on the patient's finger, and therefore, the PD 335b may not adequately detect or register light signals from the LED 335a (as shown in FIG. 3B), thereby producing a low quality signal (e.g., a pleth signal) that may result in an inaccurate blood pressure measurement.

[0024] Embodiments shown in FIGS. 4A-4D, which are diagrams illustrating cross-sectional views of examples of a finger cuff 400 according to embodiments of the invention, may be utilized. Finger cuff 400 may mitigate or eliminate many of the problems associated with the convention finger cuff 300.

[0025] With reference to FIG. 4A, finger cuff 400 may be wrapped around a patient's finger 310 having finger bone 320 and finger arteries 330 (as previously described). Similar to the conventional finger cuff 300, finger cuff 400 may include a first side and a second side, and may be formed of flexible material with a Velcro clamping system or may be a fixed finger cuff, as previously described. Further, as with the conventional finger cuff 300, finger cuff 400 may utilize any type of attachment mechanism (e.g., adhesive, tape, mechanical latching mechanisms, etc.) and finger cuff 400 may be any type of wrappable finger cuff, fixed type of finger cuff, or any type of finger cuff structure, as previously described.

[0026] As shown in FIG. 4A, in one embodiment, finger cuff 400 may include a bladder 440, an LED-PD pair 425a-b, and an LED-PD pair 435a-b, mounted on the interior of the finger cuff 400. In one embodiment, bladder 440 may include openings that surround the LED-PD pair 425a-b and LED-PD pair 435a-b. The bladder 440, LED-PD

pair 425a-b, and LED-PD pair 435a-b may be coupled to a tube or cable through a connector, which may be attached to finger cuff 400, to provide pneumatic pressure to the bladder 440, and to provide power to and receive data from the LED-PD pair 425a-b and LED-PD pair 435a-b.

[0027] Operationally, LED 425a and LED 435a may concurrently, alternatively, or in pre-defined sequences, transmit or emit light in different directions through finger arteries 330. In this scenario, the light from the LED 425a and LED 435a may be detected and registered by one or both of PD 425b and PD 435b (depending on the directions of the light) to generate a pleth signal from each PD 425b and PD 435b to create a more accurate optimal quality pleth signal. For example, each of the pleth signals generated may be averaged, or another type of algorithm may be utilized, to combine the pleth signals to generate an optimal quality pleth signal. Therefore, the additional LED-PD pair (e.g., LED-PD pair 435a-b) is utilized for additional light signal recognition and the increased number of light signals (e.g., pleth signals) transmitted through the finger arteries 330 and received by the PDs may result in increased signal quality and, in particular, may be utilized to generate an optimal quality pleth signal. Accordingly, an optimal quality pleth signal may be generated from the pleth signals received from the LED-PD pair 425a-b and LED-PD pair 435a-b.

[0028] As an example, as part of the volume clamp method, the pneumatic pressure is applied to the bladder 440 of the finger cuff based upon measuring the pleth signals received from the LED-PD pair 425a-b and LED-PD pair 435a-b of the finger cuff (e.g., to keep the optimal quality pleth signal constant) so that the pressure applied to the bladder 440 and measured by a pressure sensor should be correlated to the patient's blood pressure.

[0029] In another embodiment, with reference to FIGS. 4B-4D, the finger cuff 400 may include the bladder 440, LEDs 450, and PDs 455 mounted on the interior of the finger cuff 400. In one embodiment, the bladder 440 may include openings that surround the LEDs 450 and PDs 455. The bladder 440, LEDs 450, and PDs 455 may be coupled to a tube or cable through a connector, which may be attached to finger cuff 400, to provide pneumatic pressure to the bladder 440, and to provide power to the LEDs 450 and receive data from the PDs 455. The LEDs 450 and the PDs 455 may be aligned with one another, respectively, to form multiple LED-PD pairs. That is, each of the LEDs 450 may be effectively positioned to align with a corresponding PD from the PDs 455 to form the LED-PD pairs, which may be of an array formation in some embodiments. It should be appreciated that while three LED-PD pairs are shown in FIGS. 4B-4D, any suitable number of LED-PD pairs may be utilized.

[0030] It should be appreciated that the operational aspects of FIG. 4B-4D, are very similar to the operational aspects previously described with reference to FIG. 4A. Operationally, LEDs 450 may concurrently, alternatively, or in pre-defined sequences, transmit or emit light in different directions through finger arteries 330. In this scenario, the light from each of the LEDs 450 may be detected and registered by one or all of the PDs 455 to generate a pleth signal from each PD 455 to create a more accurate optimal quality pleth signal. For example, each of the pleth signals generated may be averaged, or another type of algorithm may be utilized, to combine the pleth signals to generate an optimal quality pleth signal. Therefore, all of the PDs 455 are utilized for

additional light signal recognition and the increased number of light signals (e.g., pleth signals) transmitted through the finger arteries 330 by the LEDs 450 and received by the PDs 455 may result in increased signal quality and, in particular, may be utilized to generate an optimal quality pleth signal. Accordingly, an optimal quality pleth signal may be generated from the pleth signals received from all of the PDs 455.

[0031] As an example, as part of the volume clamp method, the pneumatic pressure is applied to the bladder 440 of the finger cuff based upon measuring the pleth signals received from the PDs 455 of the finger cuff (e.g., to keep the optimal quality pleth signal constant) so that the pressure applied to the bladder 440 and measured by a pressure sensor should be correlated to the patient's blood pressure.

[0032] It should be noted that in these previously described embodiments, in which, multiple LED-PD pairs are utilized for pleth signal detection, an optimal location (both horizontally and vertically) for the finger cuff 400 on the patient's finger 310 in relation to the finger arteries 330 may be determined (e.g., by a health care provider) in order to perform blood pressure measurement (as shown in FIG. 4D). In particular, the finger cuff 400 may be moved (e.g., by a healthcare provider) on the patient's finger to find an optimal quality pleth signal for measurement purposes to achieve better measurement accuracy and improved blood pressure measurement.

[0033] With the previously described embodiments, the application of the finger cuff 400 to a patient's finger by a healthcare provider is less susceptible to application errors. Further, the finger cuff 400, with the increased ability to find an optimal quality pleth signal, allows for the finger cuff 400 to be single-sized or a one-size-fits-all finger cuff, such that different finger cuff sizes (as previously discussed with respect to finger cuff 300) do not need to be utilized and a single sized finger cuff 400 may be utilized for most any size finger. It should be appreciated that while LEDs and PDs are illustrated in FIGS. 4A-4D, any similar technology or interface may be utilized to determine the optimal quality signal (as previously described).

[0034] FIG. 5 is a block diagram illustrating an example environment 500 in which embodiments of the invention may be practiced. As shown in FIG. 5, finger cuff 510 may include an inflatable bladder 512, LEDs 550, and PDs 555. The LEDs 550 and PDs 555 may be respectively aligned with one another to form multiple LED-PD pairs. The inflatable bladder 512 may be pneumatically connected to a pressure generating and regulating system 520. The pressure generating and regulating system 520 and control circuitry 530 may generate, measure, and regulate pneumatic pressure that inflates or deflates the inflatable bladder 512, and may further comprise such elements as a pump, a valve, a pressure sensor, and/or other suitable elements, as previously described. In particular, pressure generating and regulating system 520 in cooperation with control circuitry 530 may be configured to implement a volume clamp method with the finger cuff 510 by: applying pneumatic pressure to the inflatable bladder 512 of the finger cuff 510 to replicate the patient's blood pressure based upon measuring pleth signals received from the LED-PD pairs (i.e., LEDs 550 and PDs 555) (e.g., to keep the pleth signal constant), and measuring the patient's blood pressure by monitoring the pressure of the inflatable bladder 512 based upon input from a pressure sensor, which should be the same or correlated to the patient's blood pressure, and may further command the

display of the patient's blood pressure on the patient monitoring device. As previously described, by utilizing multiple aligned LED-PD pairs an optimal pleth signal may be generated.

[0035] It should be appreciated that aspects of the invention previously described may be implemented in conjunction with the execution of instructions by processors, circuitry, controllers, control circuitry, etc. As an example, control circuitry may operate under the control of a program, algorithm, routine, or the execution of instructions to execute methods or processes in accordance with embodiments of the invention previously described. For example, such a program may be implemented in firmware or software (e.g. stored in memory and/or other locations) and may be implemented by processors, control circuitry, and/or other circuitry, these terms being utilized interchangeably. Further, it should be appreciated that the terms processor, microprocessor, circuitry, control circuitry, circuit board, controller, microcontroller, etc., refer to any type of logic or circuitry capable of executing logic, commands, instructions, software, firmware, functionality, etc., which may be utilized to execute embodiments of the invention.

[0036] The various illustrative logical blocks, processors, modules, and circuitry described in connection with the embodiments disclosed herein may be implemented or performed with a general purpose processor, a specialized processor, circuitry, a microcontroller, a digital signal processor (DSP), an application specific integrated circuit (ASIC), a field programmable gate array (FPGA) or other programmable logic device, discrete gate or transistor logic, discrete hardware components, or any combination thereof designed to perform the functions described herein. A processor may be a microprocessor or any conventional processor, controller, microcontroller, circuitry, or state machine. A processor may also be implemented as a combination of computing devices, e.g., a combination of a DSP and a microprocessor, a plurality of microprocessors, one or more microprocessors in conjunction with a DSP core, or any other such configuration.

[0037] The steps of a method or algorithm described in connection with the embodiments disclosed herein may be embodied directly in hardware, in a software module/firmware executed by a processor, or any combination thereof. A software module may reside in RAM memory, flash memory, ROM memory, EPROM memory, EEPROM memory, registers, hard disk, a removable disk, a CD-ROM, or any other form of storage medium known in the art. An exemplary storage medium is coupled to the processor such the processor can read information from, and write information to, the storage medium. In the alternative, the storage medium may be integral to the processor.

[0038] The previous description of the disclosed embodiments is provided to enable any person skilled in the art to make or use the present invention. Various modifications to these embodiments will be readily apparent to those skilled in the art, and the generic principles defined herein may be applied to other embodiments without departing from the spirit or scope of the invention. Thus, the present invention is not intended to be limited to the embodiments shown herein but is to be accorded the widest scope consistent with the principles and novel features disclosed herein.

What is claimed is:

1. A finger cuff attachable to a patient's finger to be used in measuring the patient's blood pressure by a blood pressure measurement system utilizing a volume clamp method, the finger cuff comprising:

a bladder configured to exert pressure on the patient's finger; and

a plurality of light emitting diodes (LEDs) and a plurality of photodiodes (PDs) that respectively align with one another to form a plurality of LED-PD pairs, wherein, when the finger cuff is placed around the patient's finger, the bladder and the plurality of LED-PD pairs aid in measuring the patient's blood pressure by the blood pressure measurement system utilizing the volume clamp method.

2. The finger cuff of claim 1, wherein the plurality of LED-PD pairs are positioned in an array formation.

3. The finger cuff of claim 2, wherein the LEDs concurrently emit light in one or more directions through the patient's finger, wherein the light is detected by at least one of the PDs of the plurality of LED-PD pairs.

4. The finger cuff of claim 2, wherein the LEDs concurrently emit light in one or more directions through the patient's finger, wherein the light is detected by each of the PDs of the plurality of LED-PD pairs.

5. The finger cuff of claim 4, wherein an optimal quality pleth signal is generated based on pleth signals generated by the LED-PD pairs.

6. The finger cuff of claim 5, wherein the generated optimal quality pleth signal enables the finger cuff to be utilized as a one-size-fits-all finger cuff for attachment to the patient's finger.

7. A method to measure a patient's blood pressure by a blood pressure measurement system utilizing a finger cuff and a volume clamp method, the finger cuff comprising a bladder, and a plurality of light emitting diodes (LEDs) and a plurality of photodiodes (PDs) that respectively align with one another to form a plurality of LED-PD pairs, the method comprising:

placing the finger cuff around a patient's finger such that the bladder and the LED-PD pairs aid in measuring the patient's blood pressure by the blood pressure measurement system utilizing the volume clamp method; emitting, by the LEDs, light in one or more directions through the patient's finger; and detecting, by each of the PDs, the light from the LEDs of the plurality of LED-PD pairs.

8. The method of claim 7, further comprising: generating, by each of the LED-PD pairs, a pleth signal based on the detected light; and generating an optimal quality pleth signal based on the pleth signals generated by the LED-PD pairs.

9. The method of claim 7, wherein the plurality of LED-PD pairs are positioned in an array formation.

10. The method of claim 9, wherein the determined optimal quality signal enables the finger cuff to be utilized as a one-size-fits-all finger cuff for attachment to the patient's finger.

11. A blood pressure measurement system utilizing a volume clamp method, the blood pressure measurement system comprising:

a finger cuff attachable to a patient's finger to be used in measuring the patient's blood pressure by the blood pressure measurement system utilizing the volume clamp method, the finger cuff comprising:

a bladder configured to exert pressure on the patient's finger; and

a plurality of light emitting diodes (LEDs) and a plurality of photodiodes (PDs) that respectively align with one another to form a plurality of LED-PD pairs, wherein, when the finger cuff is placed around the patient's finger, the bladder and the plurality of LED-PD pairs aid in measuring the patient's blood pressure by the blood pressure measurement system.

12. The blood pressure measurement system of claim 11, wherein the plurality of LED-PD pairs are positioned in an array formation.

13. The blood pressure measurement system of claim 12, wherein the LEDs concurrently emit light in one or more directions through the patient's finger, wherein the light is detected by at least one of the PDs of the plurality of LED-PD pairs.

14. The blood pressure measurement system of claim 12, wherein the LEDs concurrently emit light in one or more directions through the patient's finger, wherein the light is detected by each of the PDs of the plurality of LED-PD pairs.

15. The blood pressure measurement system of claim 14, wherein an optimal quality pleth signal is generated based on pleth signals generated by the LED-PD pairs.

16. The blood pressure measurement system of claim 15, wherein the generated optimal quality pleth signal enables the finger cuff to be utilized as a one-size-fits-all finger cuff for attachment to the patient's finger.

* * * * *

专利名称(译)	手指袖带利用多个传感器进行血压测量		
公开(公告)号	US20190082982A1	公开(公告)日	2019-03-21
申请号	US16/133539	申请日	2018-09-17
[标]申请(专利权)人(译)	爱德华兹生命科学公司		
申请(专利权)人(译)	爱德华生命科学公司		
当前申请(专利权)人(译)	爱德华生命科学公司		
[标]发明人	LI PEIYUAN VAN DER SAR GEERTRUIDA LUCRETIA GUELEN ILJA		
发明人	LI, PEIYUAN VAN DER SAR, GEERTRUIDA LUCRETIA GUELEN, ILJA		
IPC分类号	A61B5/022 A61B5/0225 A61B5/00		
CPC分类号	A61B5/02241 A61B5/02255 A61B5/6826 A61B5/02141 A61B5/02422 A61B5/0295 A61B5/14552		
优先权	62/561072 2017-09-20 US		
外部链接	Espacenet USPTO		

摘要(译)

本发明公开了一种手指套，其可附接到患者的手指，以通过利用体积钳方法的血压测量系统来测量患者的血压。指套包括囊，该囊配置成对患者的手指施加压力。指套还包括多个发光二极管（LED）和多个光电二极管（PD），它们分别彼此对准以形成多个LED-PD对。当指套围绕患者的手指放置时，膀胱和多个LED-PD对有助于通过血压测量系统利用容量钳方法测量患者的血压。

