



US 20160345845A1

(19) **United States**

(12) **Patent Application Publication**
RAVID et al.

(10) **Pub. No.: US 2016/0345845 A1**
(43) **Pub. Date: Dec. 1, 2016**

(54) **SYSTEMS, APPARATUSES AND METHODS FOR DETERMINING BLOOD PRESSURE**

A61B 5/0285 (2006.01)

A61B 5/024 (2006.01)

A61B 5/0456 (2006.01)

(71) Applicant: **KYMA MEDICAL TECHNOLOGIES LTD.**, Kfar Saba (IL)

(52) **U.S. Cl.**
CPC *A61B 5/02125* (2013.01); *A61B 5/02416* (2013.01); *A61B 5/0456* (2013.01); *A61B 5/0285* (2013.01); *A61B 5/6804* (2013.01)

(72) Inventors: **Rafi RAVID**, Savion (IL); **Uriel WEINSTEIN**, Mazkeret Batya (IL)

(73) Assignee: **KYMA MEDICAL TECHNOLOGIES LTD.**, Kfar Saba (IL)

(57) **ABSTRACT**

(21) Appl. No.: **15/117,168**

(22) PCT Filed: **Feb. 5, 2015**

(86) PCT No.: **PCT/IL15/50140**

§ 371 (c)(1),

(2) Date: **Aug. 5, 2016**

Related U.S. Application Data

(60) Provisional application No. 61/935,958, filed on Feb. 5, 2014.

Publication Classification

(51) **Int. Cl.**
A61B 5/021 (2006.01)
A61B 5/00 (2006.01)

The present disclosure is directed to apparatuses, systems and methods for measuring time-varying radar cross section (RCS) of an artery of a patient, which may be used to determine blood pressure of a patient. In some embodiments, an apparatus is provided which comprises a radio-frequency (RF) transceiver for generating RF waves, and at least one sensor configured for positioning on or adjacent the skin of a patient, and at least one of transmitting the RF waves into tissue of the patient and receiving RF wave reflections from at least one artery located within the tissue. The apparatus may further comprise a processor having computer instructions operating thereon configured to cause the processor to determine an RF arterial pulse waveform based on the received RF wave reflections. The time-varying radar cross section (RCS) comprises the RF arterial pulse waveform. This may be in turn correlated to blood pressure of the patient.

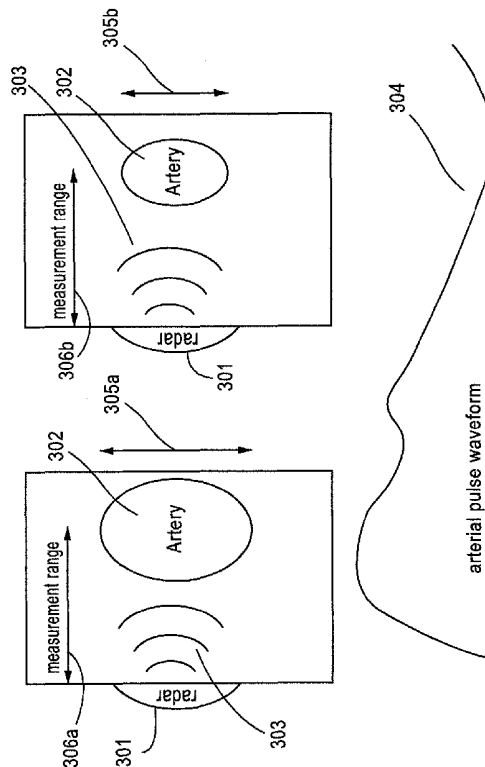

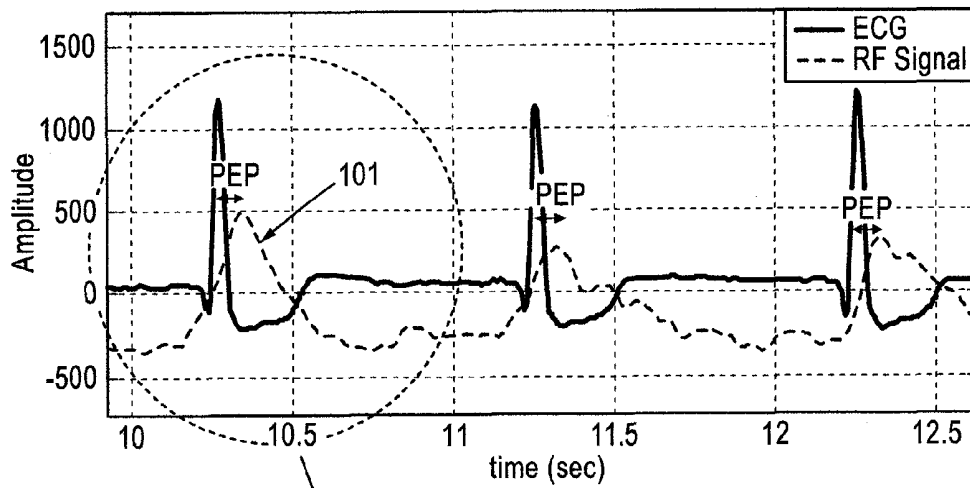

FIG. 1A

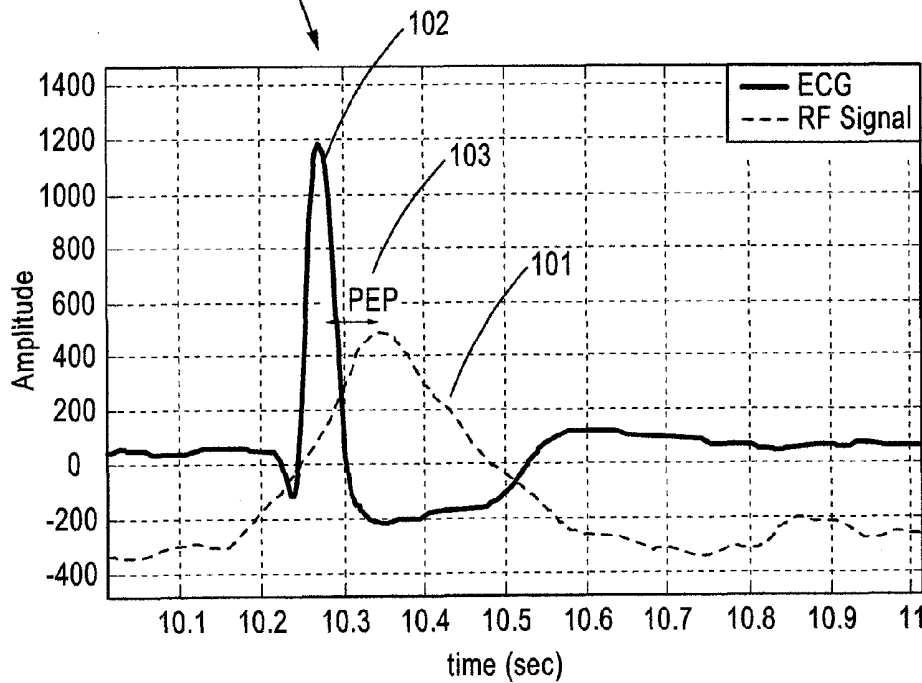

FIG. 1B

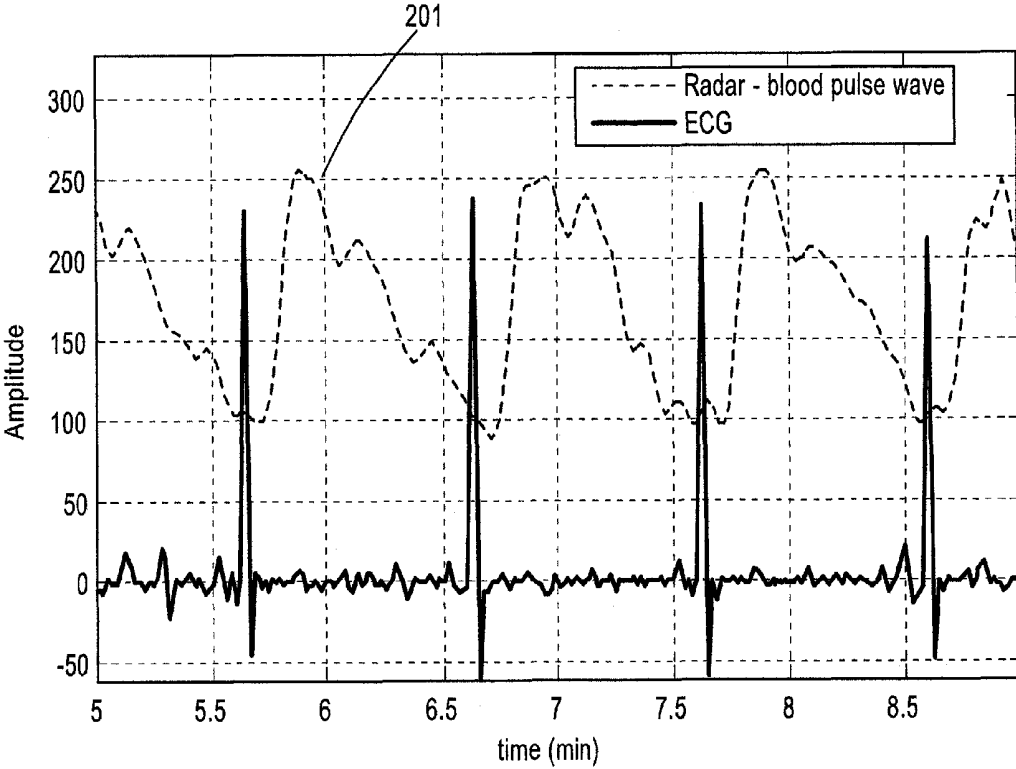

FIG. 2

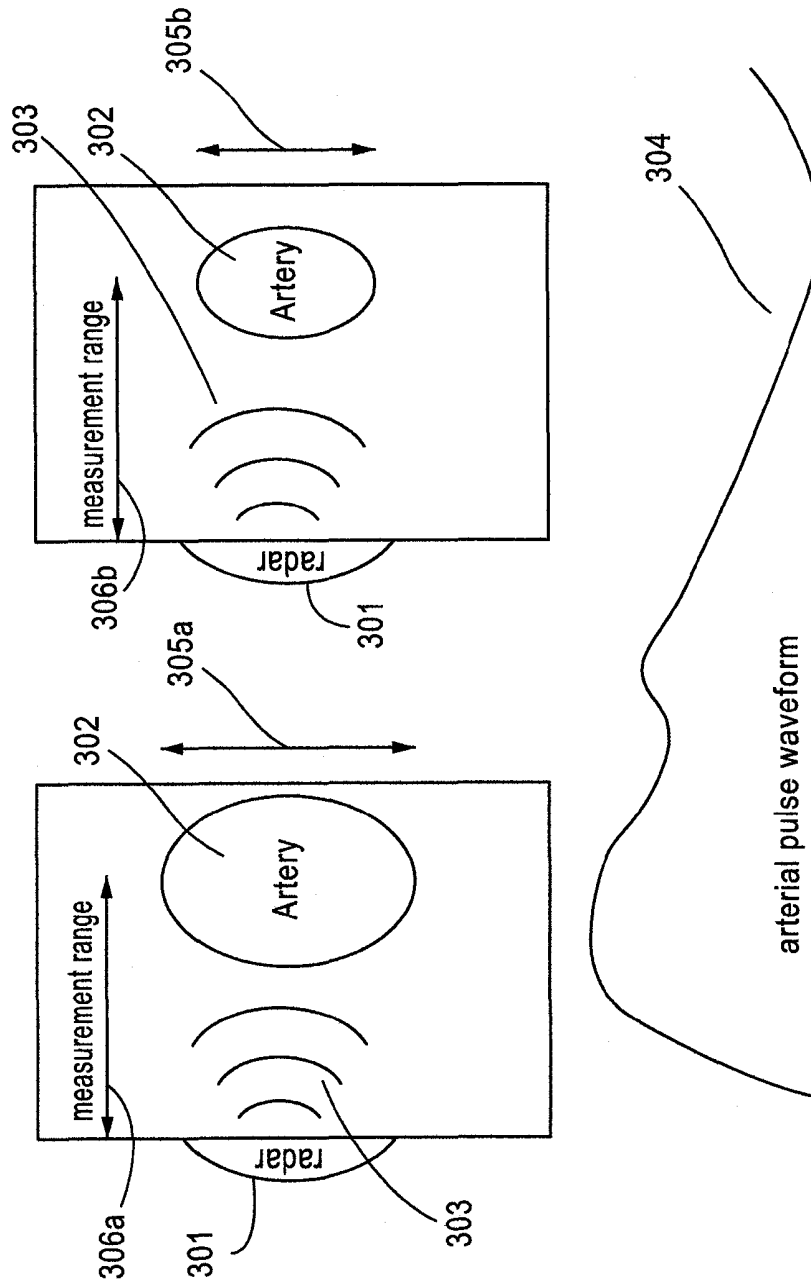

FIG. 3

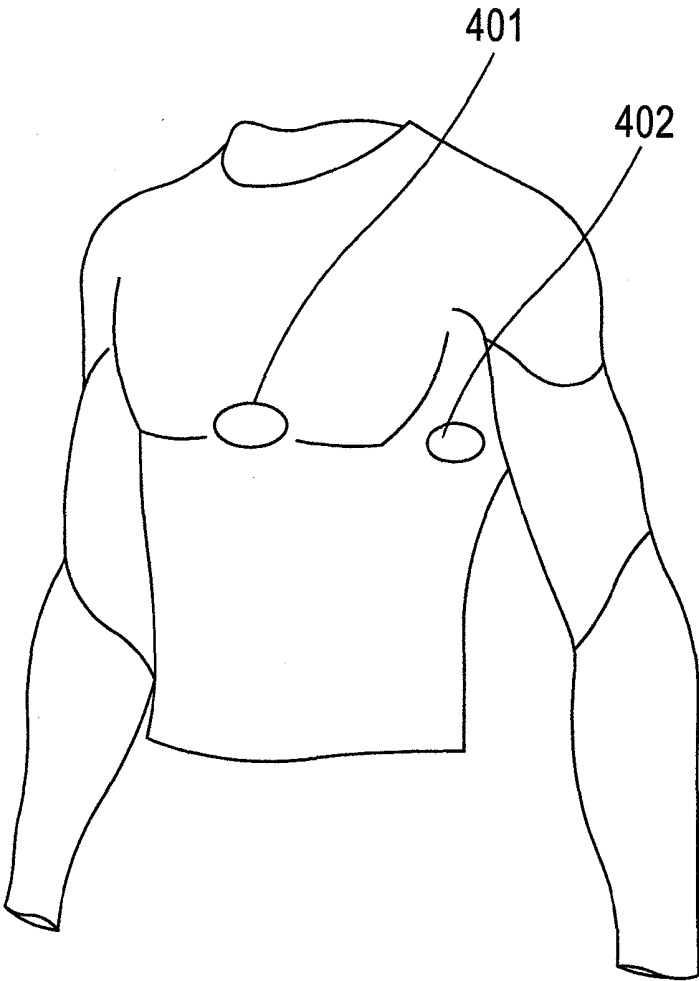

FIG. 4

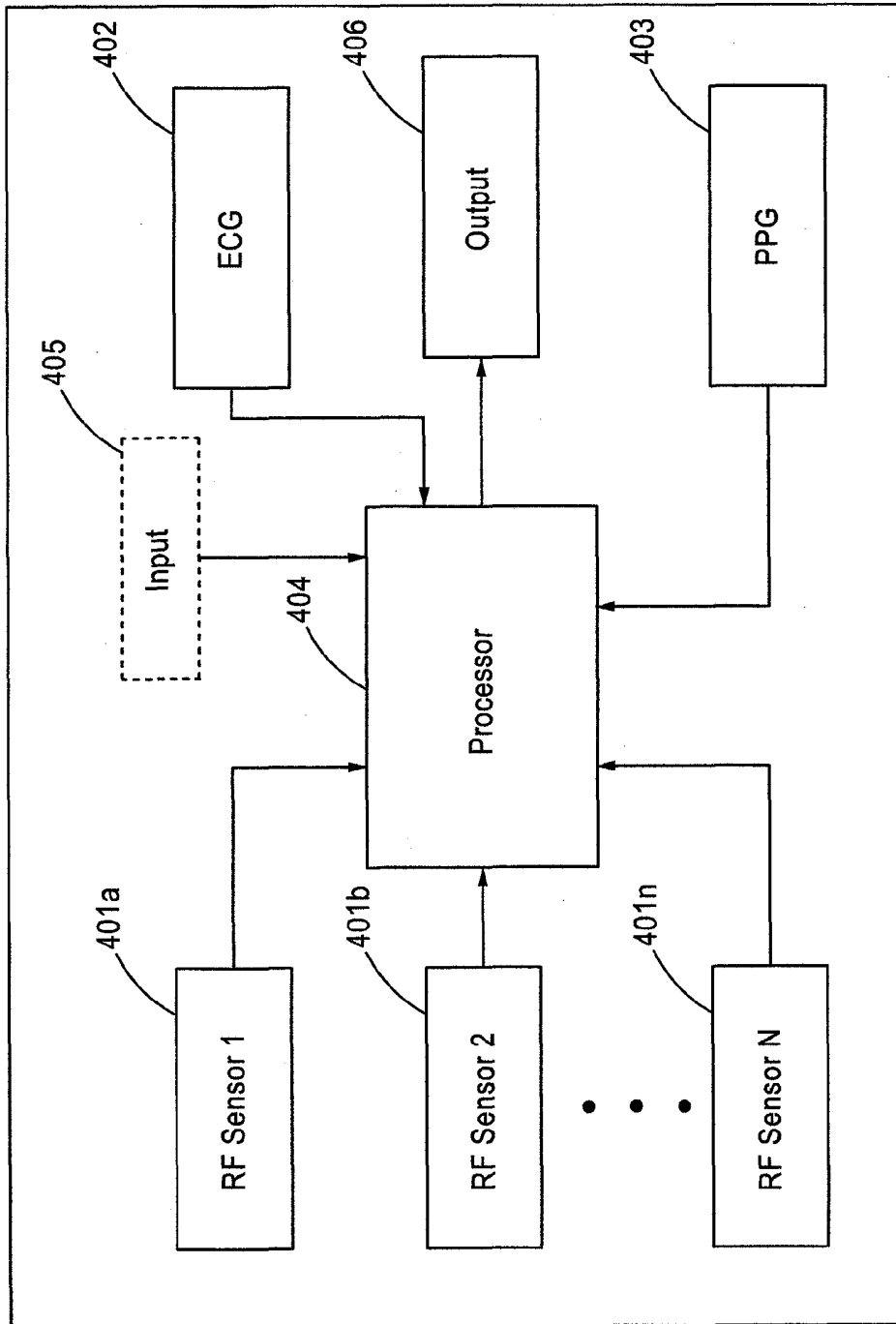

FIG. 5

SYSTEMS, APPARATUSES AND METHODS FOR DETERMINING BLOOD PRESSURE

CROSS-REFERENCE TO RELATED APPLICATIONS

[0001] This application is a non-provisional of and claims priority under 35 USC §119 to: U.S. provisional patent application Ser. No. 61/935,958 filed Feb. 5, 2014, entitled "Systems and Methods for Determining Blood Pressure Using Electromagnetic Waves."

FIELD OF THE DISCLOSURE

[0002] Embodiments of the current disclosure are directed toward blood pressure measurement, and more particularly, systems and methods for blood pressure measurement utilizing electromagnetic radiation/waves.

BACKGROUND OF THE DISCLOSURE

[0003] Radio-frequency (RF) electromagnetic radiation has been used for diagnosis and imaging of body tissues, examples of which may be found in PCT publication no. WO2011/067623, US publication nos. 2009/0299175 and 2009/0240133, and U.S. Pat. Nos. 4,926,868 and 5,766,208.

[0004] WO 2011/067623 is understood to be directed to a diagnostic apparatus that includes an antenna, which directs RF electromagnetic waves into a living body and generates signals responsively to the waves that are scattered from within the body. US patent publication no. 2009/0240133 is understood to be directed to a radio apparatus and method for non-invasive, thoracic radio interrogation of a subject for the collection of hemodynamic, respiratory and/or other cardiopulmonary related data. US patent publication no. 2009/0299175, is understood to be directed to a method and apparatus for determining and tracking the location of a metallic object in a living body, using a radar detector adapted to operate on a living body. U.S. Pat. No. 4,926,868 is understood to be directed to a method and apparatus for cardiac hemodynamic monitoring based on the complex field amplitudes of microwaves propagated through and scattered by thoracic cardiovascular structures, particularly the heart chambers, as a function of time during the cardiac cycle.

[0005] However, none of these references are understood to disclose ascertaining blood pressure utilizing radio-frequency (RF) waves.

SUMMARY OF SOME OF THE EMBODIMENTS

[0006] Embodiments of the present disclosure present methods, systems and apparatuses techniques for continuous Non-Invasive Blood Pressure (cNIBP) measurement are discussed in the present disclosure (in some embodiments, such measurements may be non-continuous). In such embodiments, cNIBP measurements may be accomplished by determining, for example, Pulse Wave Velocity (PWV), which can be used as, for example, a measure of arterial stiffness. In some instances, PWV corresponds to the velocity of propagation of the arterial pressure pulse between points along the arterial tree, which may depend on, amongst other things, the blood pressure. Accordingly, determination of PWV and/or the pulse transit time (PTT) between points along the arterial tree may provide information on the blood pressure in the arteries.

[0007] In some embodiments, one or more sensors may be used to determine the PTT, and/or the pulse wave arrival time, which may also be referred to as the pulse arrival time (PAT), which may be different from the PTT. For example, there may be a delay between the generation of the pulse by the ventricular muscle and the opening of the aortic valve. In some instances, when using sensors such as an electrocardiogram (ECG) device and a photo-plethysmograph (PPG), the PAT may correspond to the delay between the ECG's QRS peak (e.g., R-peak) and a point on the PPG signal representing the pressure pulse at a peripheral artery. Examples of such sensors comprise ECGs, PPGs, radio-frequency (RF) sensors, etc. In some embodiments, the RF sensor allows for determination/estimation of the arterial pulse waveform which may provide clinical information such as, but not limited to, arterial stiffness, PWV, cardiac output, cNIBP measurements, etc.

[0008] In some embodiments, an apparatus and a method for measuring time-varying radar cross section (RCS) of an artery of a patient are disclosed. The apparatus comprises a RF transceiver for generating RF waves, at least one sensor configured for positioning on or adjacent the skin of a patient, and at least one of transmitting the RF waves into tissue of the patient and receiving RF wave reflections from at least one artery located within the tissue. In some implementations, the at least one sensor comprises at least one antennae. In some instances, it may be configured with flexibility that allows the sensor to conform to the skin of the patient. The apparatus also comprises a processor having computer instructions operating thereon configured to cause the processor to execute some or all steps of the method disclosed herein. The steps of the method comprise determining an RF arterial pulse waveform based on the received RF wave reflections, where the time-varying RCS comprises the RF arterial pulse waveform.

[0009] In some embodiments, the method also comprises the steps of correlating the time-varying RCS to a time-varying diameter of the at least one artery, conditioning the RF arterial pulse waveform using at least one radar echo from a specific range, and adapting the specific range to the at least one artery. In some implementations, the steps also include conditioning the RF arterial pulse waveform using band pass filtering, and determining a time location of at least one of a peak of the RF arterial pulse waveform, the first derivative peak, and other points marking an RF-arterial-pulse-arrive-time (RE-PAT). In some embodiments, the methods include the steps of characterizing the RF arterial pulse waveform. For example, characterizing may comprise determining a timing of the dirotic notch of the waveform.

[0010] In some embodiments, the apparatus comprises an ECG sensor configured for positioning on the body of the patient for receiving signals corresponding to an ECG waveform, where signals from the ECG sensor are synchronized with the RF wave reflections. In some instances, the method includes determining arterial-pulse-arrival-time (PAT) based on a time difference between the RF-PAT and an R-peak of the ECG waveform. The apparatus may also comprise an ECG sensor configured for positioning on the body of the patient for receiving signals corresponding to an ECG waveform. Further, the apparatus may include the at least one sensor positioned to receive RF wave reflections from the aorta of the patient, where signals from the ECG sensor are synchronized with the RF wave reflections. In

some instances, the method may comprise the step of determining an R-peak of the ECG waveform, and determining a time difference between the RF-arterial-pulse-arrival-time (RF-PAT) and the R-peak to determine a pre-ejection period (PEP). In addition, the computer instructions may be further configured to cause the processor to determine PTT, where PTT is determined by subtracting PEP from PAT.

[0011] In some embodiments, the at least one sensor may be configured for sensing RF wave reflections corresponding to PAT at each of two different arterial tree locations. In some instances, the method includes the step of determining the PAT at each location and determining the difference between the PAT at the two locations so as to determine a PTT. The two different arterial tree locations may be discerned based on depth resolution of the tissue. In some embodiments, the apparatus may comprise a second sensor, where the first sensor is configured for sensing RF wave reflections corresponding to PAT at a first arterial tree location, and where the second sensor is configured for sensing signals corresponding to PAT at a second arterial tree location. In some embodiments, the method includes determining the PAT at each location and determining the difference between the PAT at the two locations so as to determine the PTT. In such embodiments, the first arterial tree location and the second arterial tree location comprise different locations on the same arterial tree. In some instances, the first arterial tree location and the second arterial tree location comprise different arterial trees. In some instances, the first arterial tree location and the second arterial tree location may comprise different arterial trees on different areas of the body of a patient.

[0012] In some embodiments, the method comprises the step of utilizing an ECG waveform of the patient to synchronize the first and second sensors. Further, it includes gating the time measurement between the first and second sensors, where one sensor gates the measurement of the other.

[0013] In some of the embodiments disclosed above, the second sensor comprises a photo-plethysmograph (PPG) sensor or an RF sensor. In addition, the method includes the step of determining the patient's blood pressure as a function of PTT, where parameters used to determine NT are calibrated for the patient. In some embodiments, the method includes determining arterial PWV, where PWV equals the propagation distance of the arterial pulse wave divided by PTT.

[0014] It should be appreciated that all combinations of the foregoing concepts and additional concepts discussed in greater detail below (provided such concepts are not mutually inconsistent) are contemplated as being part of the inventive subject matter disclosed herein. In particular, all combinations of claimed subject matter appearing at the end of this disclosure are contemplated as being part of the inventive subject matter disclosed herein. It should also be appreciated that terminology explicitly employed herein that also may appear in any disclosure incorporated by reference should be accorded a meaning most consistent with the particular concepts disclosed herein.

BRIEF DESCRIPTION OF THE DRAWINGS

[0015] The skilled artisan will understand that the drawings primarily are for illustrative purposes and are not intended to limit the scope of the inventive subject matter

described herein. The drawings are not necessarily to scale; in some instances, various aspects of the inventive subject matter disclosed herein may be shown exaggerated or enlarged in the drawings to facilitate an understanding of different features. In the drawings, like reference characters generally refer to like features (e.g., functionally similar and/or structurally similar elements).

[0016] FIGS. 1A-B shows an example embodiment of determination of the pre-ejection period (PEP) from electrocardiogram and radio-frequency signal measurements.

[0017] FIG. 2 shows a diagram depicting an example arterial pulse waveform.

[0018] FIG. 3 shows the measurement of arterial pulse waveform from a changing (e.g., time-varying) radar cross section of an artery during cardiac pressure cycle.

[0019] FIG. 4 illustrates an example placement of radio-frequency sensors over the thorax.

[0020] FIG. 5 depicts an example schematic diagram of the components of the apparatus for measuring time-varying radar cross section (RCS) of an artery disclosed herein.

DETAILED DESCRIPTION OF SOME OF THE EMBODIMENTS

[0021] In some embodiments of the present disclosure, systems and methods for determining blood pressure using electromagnetic waves are presented. For example, RF sensors (e.g., antenna) may be utilized to receive and/or transmit RF signals. In some instances, the RF signal waveform can be continuous or based on step frequency. In some implementations, the signals may have a wide range of frequencies, for example, the RF frequency may range from about 300 MHz to about 3 GHz. In some embodiments, the RF sensor can achieve a range (e.g., depth) resolution that allows filtering of reflections from relevant depth in a patient's body. For example, the sensor may allow penetration of a few centimeters into the body, facilitating its usage for a variety of arteries (e.g. anterior tibial, popliteal, brachial, carotid, etc.).

[0022] In some implementations, the RF sensors may be used in conjunction with other sensors/devices, such as (for example) an ECG sensor/device and/or a PPG sensor, to determine PTT and/or PAT of a pulse wave in an artery. In some embodiments, there may be a time lapse between the ventricular polarization and the opening of the aortic valve—i.e., the Pre-Ejection Period (PEP)—which, in some embodiments, corresponds to the time it takes for the myocardium to raise sufficient pressure to open the aortic valve and start pushing blood out of the ventricle. In some instances, the effects of the PEP may be significant in determining blood pressure levels.

[0023] In some embodiments, the PTT to some point along the arterial tree (e.g., peripheral location in the arterial system) may be represented as the difference between the arrival time of the pulse at the point and the pre-ejection period, i.e., $PTT = PAT - PEP$. Upon determining or estimating the PTT, in some embodiments, the PWV may then be calculated based on the distance the pulse traveled to arrive at the point and the estimated/determined PTT. In some implementations, blood pressure values such as systolic and/or diastolic values can be determined non-invasively from the PWV and/or the PTT. For example, linear transformations relating the systolic blood pressure (SBP) and diastolic blood pressure (DBP) to the PTT may be expressed as follow:

$$SBP=(a \times PTT)+b,$$

$$DBP=(c \times PTT)+d,$$

where the coefficients a, b, c and d can be calibrated for each patient. In some embodiments, other types of transformations may be used to calculate blood pressures. For example, for a model that assumes constant artery thickness and radius, blood pressure P may be expressed as $P=a \times \ln(PTT)+b$, where, again a and b are constants to be calibrated for each patient. In any case, in some embodiments, obtaining PTT, or conversely PWV of a pulse in an artery, may lead to the determination of blood pressure levels in the artery.

Usage of an RF Sensor and an ECG for Determining PEP Correction

[0024] In some embodiments, RF waves may be used to locate the time of the opening of the aortic valve. For example, the reflected electromagnetic signal (with sensors located in the appropriate place, and optionally after appropriate filtering) may provide information on the opening of the aortic valve, and hence can be used in conjunction with the ECG signals that represent the activation of the ventricles, for determining the PEP. Once PEP is obtained, in some embodiments, the calculation of the PTT follows from the relation $PTT=PAT-PEP$ upon finding PAT. In some instances, PAT can be found by comparing the simultaneous detection of ECG signals to that of the PPG signals, which represent the activation of the pulses at the ventricles and arrival of the pulses at the peripheral arteries, respectively. For example, the comparison may correspond to the delay between the ECG's QRS peak (i.e., R-peak) and a point on the PPG signal representing the pressure pulse at a peripheral artery. In such embodiments, one or more PPG sensors may be located near a peripheral artery (e.g., finger, ear-lobe, etc.), and one or more RF sensors (e.g., antenna) may be located so that the antennae receives reflections from the heart, for example, at the sternum. The heart signals can be isolated by a combination of range and Doppler filtering of the RF signals. For example, the RF signal may be filtered to isolate heart reflections from the relevant depth, and may also be filtered to remove reflections from static objects. As to the ECG signals, the R-peak time may be determined from the ECG signals. FIG. 1 shows an example embodiment of PEP correction estimation **103** from the time difference between the ECG R-peak **102** and the RF signal pulse **101**.

[0025] In some embodiments, the RF sensor can be utilized to obtain the arterial pulse waveform, which may provide clinical information such as, but not limited to, arterial stiffness, PWV, cardiac output, cNIBP measurements, and the like. For example, the sensor may scan the cross section of objects in its view, which may include an artery. As such, as the pulse wave is propagating through the artery, the RF sensor may measure the changing radar cross section of the artery. In such instances, the changing arterial cross section is related to the pulse wave, and accordingly the arterial pulse waveform may be determined from the changing cross section. An example arterial pulse wave **201** obtained using this method is depicted in FIG. 2. This method has several advantages in that in obtaining the arterial pulse waveform, it is at least non-invasive, allows penetration into the body, and/or can be operated with little or no expertise.

[0026] FIG. 3 shows the measurement of arterial pulse waveform from a changing (e.g., time-varying) RCS of an artery during cardiac pressure cycle, according to some embodiments. For example, during a cardiac cycle, an RF radar sensor **301** may generate and transmit RF waves **303** towards an artery **302** which may be located at a certain depth from the RF sensor **301** corresponding to a measurement range **306a**. In some embodiments, some or all of the transmitted waves **303** may be reflected back to the RF sensor **301**. In some instances, the RF sensor **301** may transmit the RF waves **303** continuously or non-continuously. During the cardiac cycle, the diameter of the artery **302** may be varying over time, e.g., **305a** and **305b**, and as a result the RCS of the artery **302** obtained by the RF sensor **301** changes over time as well. From the measurements of the varying RCS, in some implementations, an arterial pulse waveform **304** representing the pulse wave propagating through the artery may be determined. In turn, from the arterial pulse waveform **304**, a variety of clinical information such as but not limited to arterial stiffness, PWV, cardiac output, blood pressure measurements (continuous or non-continuous) may be obtained. In some embodiments, the reflected echo may be modulated by the artery over the course of the cardiac cycle, and information from the reflected echo can be used to determine/estimate the arterial pulse waveform **304**. For example, the measurement range **306a** may change over the course of the cardiac cycle (e.g., **306a** and **306b**), leading to changes in the phase of the reflected waves. In such instances, such information can be utilized to determine/estimate the arterial pulse waveform **304**.

Usage of RF Waves for Determining PAT

[0027] In some embodiments, RF waves may be used to determine the PAT. As discussed above, the ECG signals represent the activation of the ventricles, i.e., the onset of the pulse wave. As such, a determination of the arrival of the pulse at a location on an artery may allow for an estimation/determination of the PAT by comparing the ECG signals with time of arrival for the pulse. In some embodiments, the location may be at a peripheral artery (e.g., fingers, ear lobes, etc.). In some embodiments, the location may be at a depth inside a body, which as discussed above is one advantage of using RF signals. For example, the RF sensor can be located in a variety of places on the body, which allows for the ability of the RF waves to penetrate into a particular depth into the body. In some embodiments, this may allow for choosing an artery for observation (i.e., not necessarily in the finger or earlobe). The RF reflections may be used to identify the time of arrival of the pulse wave to the chosen artery, and the PAT may be determined from the time difference between the ECG R-peak and the RF signal pulse arrival time.

Usage of Two RF Sensors for Determining PTT

[0028] In some embodiments, the PTT of the pulse can be determined if the times of arrival of the pulse at two distinct locations can be measured. This follows because the PEP values of the pulse that originated at the same ventricle but arrived at the two different locations is the same, and accordingly, the difference in PAT for the two locations is the same as the difference in PTT of the pulse to the two distinct locations. For example, FIG. 4 shows two RF sensors **401**

and **402** located at different positions on the body (e.g., the sternum and the thorax, two suitable locations along the leg, etc.) can be used to sense the pulse wave going through arteries close to each RF sensor. In some embodiments, the RF sensors may be incorporated into clothing (e.g., stockings, shirts, etc.), chest straps, wrist straps, skin patches, and/or the like.

[0029] In some embodiments, for each of the RF sensors, the RF signal may be filtered to isolate the reflections from the relevant depth and to remove reflections from static objects. In such embodiments, the PTT may be determined as the time difference between the pulse wave arrival times as measured by the two RF sensors. It is worth noting that the two RF sensors, in some embodiments, may be synchronized. An example way to achieve synchronization may be by using two ECG sensors, where the R peak can be viewed as the synchronizing marker.

Usage of an RF Sensor and a PPG for Determining PTT

[0030] As discussed above, the PTT of the pulse can be determined if the times of arrival of the pulse at two distinct locations can be measured. In the previous embodiments, the two locations were disclosed to be at the peripheries of arteries, for example, at the sternum and the thorax, at two suitable locations along the leg, etc. In other embodiments, both locations may not be on the peripheries of arteries as discussed above. For example, one of them can be at the periphery of an artery, and the other can be at a depth inside the body. For example, two co-located sensors, an RF sensor and a PPG sensor, may detect, respectively, an artery located inside the body and a peripheral artery (e.g., on a finger, ear lobes, etc.). In some embodiments, the RF sensor may be used to penetrate into the body and reflections from a specific depth in the body can be isolated by processing the RF echoes. The PPG sensor (e.g., used in reflective mode) may be used to measure reflections from superficial arteries, and the pulse wave of these arteries may then be measured by the PPG. Since the types of observed arteries have a different path from the heart, in some implementations, they therefore may include a different travel time. In some embodiments, this difference can be indicative of the blood pressure. For example, the sensors can be located on the thorax, where reflected RF echoes from the lungs (for example) can be isolated, and pulse waves from arteries going through the lung may be measured in this way. According to some embodiments, the pulse waves from the RF sensor and from the PPG are compared, with the time delay between them determined to be $\text{Time Delay} = (\text{PTT from the heart to the lung arteries}) - (\text{PTT from the heart to the thorax superficial arteries})$. As disclosed above, this time difference can be used to determine the blood pressure.

Usage of a Single RF Sensor for Determining PTT

[0031] In some embodiments, the determination of the PTT of a pulse may be accomplished by a single RF sensor if the times of arrival of the pulse at two distinct locations can be measured using the single sensor. Above, example embodiments have been disclosed where the two distinct locations are at peripheries of arteries, and other embodiments where one location is at a periphery of artery and the other at a depth inside the body. In some embodiments, the two locations may be inside the body at different depths. For

example, the single RF sensor may be located in a position where it receives signals for deciphering different arteries at different depths in the body. For example, the sensor may detect pulse waves arriving at different arteries belonging to different branches at different depths in an arterial tree. In such embodiments, the sensor may measure their arrival times at the different depths, and determine/estimate the PTT from the time difference between the arrival times.

[0032] FIG. 5 depicts an example schematic diagram of the components of the apparatus for measuring time-varying radar cross section (RCS) of an artery disclosed herein. For example, the apparatus may comprise one or more RF sensors **501**. Further, it may also include an ECG sensor **502** configured for receiving signals corresponding to an ECG waveform. In some instances, the apparatus may also contain a PPG device **503**. The devices/sensors such as the RF sensors **501**, the ECG sensor **502**, the PPG device **503**, etc., may receive signals from the body of a patient (e.g., from arteries). In some embodiments, these sensors/devices may transmit data/information corresponding to the received signals to a processor **504** configured for executing computer instructions to act on the transmitted data/information. Further, the processor **504** may receive other input (e.g., patient data, variables (e.g., temperature, time, etc.), and/or the like), and upon executing computer instructions with some or more of the received input, in some embodiments, the processor **504** may generate outputs **505** such as, but not limited to, arterial pulse waveform, blood pressure measurements, etc. These outputs may be presented via any suitable media (e.g., printer, database, display, audio, and the like).

[0033] Also, various inventive concepts may be embodied as one or more methods, of which an example has been provided. The acts performed as part of the method may be ordered in any suitable way. Accordingly, embodiments may be constructed in which acts are performed in an order different than illustrated, which may include performing some acts simultaneously, even though shown as sequential acts in illustrative embodiments.

[0034] At least some of the embodiments disclosed above, in particular at least some of the methods/processes disclosed, may be realized in circuitry, computer hardware, firmware, software, and combinations thereof (e.g., a computer system). Such computing systems, may include PCs (which may include one or more peripherals well known in the art), smartphones, specifically designed medical apparatuses/devices and/or other mobile/portable apparatuses/devices. In some embodiments, the computer systems are configured to include clients and servers. A client and server are generally remote from each other and typically interact through a communication network (e.g., VPN, Internet). The relationship of client and server arises by virtue of computer programs running on the respective computers and having a client-server relationship to each other.

[0035] Some embodiments of the disclosure (e.g., methods and processes disclosed above) may be embodied in a computer program(s)/instructions executable and/or interpretable on a processor, which may be coupled to other devices (e.g., input devices, and output devices/display) which communicate via wireless or wired connect (for example).

[0036] While various inventive embodiments have been described and illustrated herein, those of ordinary skill in the art will readily envision a variety of other means and/or structures for performing the function and/or obtaining the

results and/or one or more of the advantages described herein, and each of such variations and/or modifications is deemed to be within the scope of the inventive embodiments described herein. More generally, those skilled in the art will readily appreciate that all parameters, dimensions, materials, and configurations described herein are meant to be an example and that the actual parameters, dimensions, materials, and/or configurations will depend upon the specific application or applications for which the inventive teachings is/are used. Those skilled in the art will recognize, or be able to ascertain using no more than routine experimentation, many equivalents to the specific inventive embodiments described herein. It is, therefore, to be understood that the foregoing embodiments are presented by way of example only and that, within the scope of the appended claims and equivalents thereto, inventive embodiments may be practiced otherwise than as specifically described and claimed. Inventive embodiments of the present disclosure are directed to each individual feature, system, article, material, kit, and/or method described herein. In addition, any combination of two or more such features, systems, articles, materials, kits, and/or methods, if such features, systems, articles, materials, kits, and/or methods are not mutually inconsistent, is included within the inventive scope of the present disclosure. Still other embodiments of the present disclosure are patentable over prior art references for expressly lacking one or more features disclosed in the prior art (i.e., claims covering such embodiments may include negative limitations).

[0037] Any and all references to publications or other documents, including but not limited to, patents, patent applications, articles, webpages, books, etc., presented anywhere in the present application, are herein incorporated by reference in their entirety. One or more features and/or embodiments disclosed in one or more of incorporated by reference documents herein can also be combined with one or more features/embodiments of the present disclosure to yield yet further embodiments (of the present disclosure).

[0038] Moreover, all definitions, as defined and used herein, should be understood to control over dictionary definitions, definitions in documents incorporated by reference, and/or ordinary meanings of the defined terms.

[0039] The indefinite articles “a” and “an,” as used herein in the specification and in the claims, unless clearly indicated to the contrary, should be understood to mean “at least one.”

[0040] The phrase “and/or,” as used herein in the specification and in the claims, should be understood to mean “either or both” of the elements so conjoined, i.e., elements that are conjunctively present in some cases and disjunctively present in other cases. Multiple elements listed with “and/or” should be construed in the same fashion, i.e., “one or more” of the elements so conjoined. Other elements may optionally be present other than the elements specifically identified by the “and/or” clause, whether related or unrelated to those elements specifically identified. Thus, as a non-limiting example, a reference to “A and/or B,” when used in conjunction with open-ended language such as “comprising” can refer, in one embodiment, to A only (optionally including elements other than B); in another embodiment, to B only (optionally including elements other than A); in yet another embodiment, to both A and B (optionally including other elements); etc.

[0041] As used herein in the specification and in the claims, “or” should be understood to have the same meaning as “and/or” as defined above. For example, when separating items in a list, “or” or “and/or” shall be interpreted as being inclusive, i.e., the inclusion of at least one, but also including more than one, of a number or list of elements, and, optionally, additional unlisted items. Only terms clearly indicated to the contrary, such as “only one of” or “exactly one of,” or, when used in the claims, “consisting of,” will refer to the inclusion of exactly one element of a number or list of elements. In general, the term “or” as used herein shall only be interpreted as indicating exclusive alternatives (i.e. “one or the other but not both”) when preceded by terms of exclusivity, such as “either,” “one of,” “only one of,” or “exactly one of.” “Consisting essentially of,” when used in the claims, shall have its ordinary meaning as used in the field of patent law.

[0042] As used herein in the specification and in the claims, the phrase “at least one,” in reference to a list of one or more elements, should be understood to mean at least one element selected from any one or more of the elements in the list of elements, but not necessarily including at least one of each and every element specifically listed within the list of elements and not excluding any combinations of elements in the list of elements. This definition also allows that elements may optionally be present other than the elements specifically identified within the list of elements to which the phrase “at least one” refers, whether related or unrelated to those elements specifically identified. Thus, as a non-limiting example, “at least one of A and B” (or, equivalently, “at least one of A or B,” or, equivalently “at least one of A and/or B”) can refer, in one embodiment, to at least one, optionally including more than one, A, with no B present (and optionally including elements other than B); in another embodiment, to at least one, optionally including more than one, B, with no A present (and optionally including elements other than A); in yet another embodiment, to at least one, optionally including more than one, A, and at least one, optionally including more than one, B (and optionally including other elements); etc.

[0043] In the claims, as well as in the specification above, all transitional phrases such as “comprising,” “including,” “carrying,” “having,” “containing,” “involving,” “holding,” “composed of,” and the like are to be understood to be open-ended, i.e., to mean including but not limited to. Only the transitional phrases “consisting of” and “consisting essentially of” shall be closed or semi-closed transitional phrases, respectively, as set forth in the United States Patent Office Manual of Patent Examining Procedures, Section 2111.03.

1-48. (canceled)

49. An apparatus for measuring time-varying radar cross section (RCS) of an artery of a patient, comprising:

a radio-frequency (RF) transceiver for generating RF waves;

at least one sensor configured for

positioning on or adjacent the skin of a patient, and
at least one of transmitting the RF waves into tissue of the patient and receiving RF wave reflections from at least one artery located within the tissue; and

a processor having computer instructions operating thereon configured to cause the processor to:
determine an RF arterial pulse waveform based on the received RE wave reflections, wherein the time-

varying radar cross section (RCS) comprises the RF arterial pulse waveform, and

correlate the time-varying RCS to a time-varying diameter of the at least one artery.

50. The apparatus of claim **49**, wherein the at least one sensor comprises at least one antennae, and/or the at least one sensor is configured with flexibility to enable the at least one sensor to conform to the skin of the patient.

51. The apparatus of claim **49**, wherein the computer instructions are additionally configured to cause the processor to condition the RF arterial pulse waveform using at least one radar echo from a specific range.

52. The apparatus of claim **49**, wherein the computer instructions are additionally configured to cause the processor to condition the RF arterial pulse waveform using band pass filtering.

53. The apparatus of claim **49**, wherein the computer instructions are additionally configured to cause the processor to characterize the RF arterial pulse waveform, characterizing the RF arterial pulse waveform including determining at least one or more of: a peak-to-peak amplitude of the RF arterial pulse waveform; a time location of at least one of a peak of the RF arterial pulse waveform, a first derivative peak, and other points marking an RF-arterial-pulse-arrive-time (RF-PAT); and a timing of a dicrotic notch of the RF arterial pulse waveform.

54. The apparatus of claim **49**, further comprising an ECG sensor configured for positioning on the body of the patient for receiving signals corresponding to an ECG waveform, wherein signals from the ECG sensor are synchronized with the RF wave reflections, and wherein the computer instructions are additionally configured to cause the processor to determine arterial-pulse-arrival-time (PAT) based on a time difference between an RF-arterial-pulse-arrive-time (RF-PAT) and an R-peak of the ECG waveform.

55. The apparatus of claim **49**, further comprising an ECG sensor configured for positioning on the body of the patient for receiving signals corresponding to an ECG waveform, wherein

the at least one sensor is positioned to receive RF wave reflections from the aorta of the patient,

signals from the ECG sensor are synchronized with the RF wave reflections, and

wherein the computer instructions are additionally configured to cause the processor to

determine an R-peak of the ECG waveform, and

determine a time difference between the RF-arterial-pulse-arrival-time (RF-PAT) and the R-peak to determine a pre-ejection period (PEP).

56. The apparatus of claim **55**, wherein the computer instructions are additionally configured to cause the processor to determine an arterial-pulse-travel-time (PTT) by subtracting the PEP from PAT.

57. The apparatus of claim **49**, wherein the at least one sensor is configured for sensing RF wave reflections corresponding to arterial-pulse-arrival-time (PAT) to each of two different arterial tree locations, the two different arterial tree locations discerned based on depth resolution of the tissue.

58. The apparatus of claim **49**, wherein the at least one sensor is configured for sensing RF wave reflections corresponding to arterial-pulse-arrival-time (PAT) to each of two different arterial tree locations, wherein the computer instructions are additionally configured to cause the proces-

sor to determine an arterial-pulse-travel-time (PTT) by determining a difference between the PAT at the two different arterial tree locations.

59. The apparatus of claim **49**, wherein the computer instructions are additionally configured to determine arterial pulse-wave velocity (PWV), wherein the PWV equals a propagation distance of the arterial pulse wave divided by PTT.

60. An apparatus for measuring time-varying radar cross section (RCS) of an artery of a patient, comprising:

a radio-frequency (RF) transceiver for generating RF waves;

a first sensor and a second sensor configured for positioning on or adjacent the skin of a patient; wherein the first sensor is configured for sensing RF wave reflections corresponding to arterial-pulse-arrival-time (PAT) at a first arterial tree location, and the second sensor is configured for sensing signals corresponding to PAT at a second arterial tree location; and

a processor having computer instructions operating thereon configured to cause the processor to:

determine the PAT at each location and determine the difference between the PAT at the two locations so as to determine an arterial-pulse-travel-time (PTT).

61. The apparatus of claim **60**, wherein the first arterial tree location and the second arterial tree location include one of the following:

different locations on the same arterial tree,

different arterial trees, and

different arterial trees on different areas of the body of a patient.

62. The apparatus of claim **60**, wherein the computer instructions are additionally configured to cause the processor to utilize an ECG waveform of the patient to synchronize the first and second sensors.

63. The apparatus of claim **60**, wherein the computer instructions are additionally configured to cause the processor to gate the time measurement between the first and second sensors, wherein one sensor gates the measurement of the other.

64. The apparatus of claim **60**, wherein the first sensor and/or the second sensor include a photo-plethysmograph (PPG) sensor or an RF sensor.

65. The apparatus of claim **60**, wherein the computer instructions are additionally configured to cause the processor to determine the patient's blood pressure as a function of arterial-pulse-travel-time (PTT), wherein parameters used to determine the PTT are calibrated for the patient.

66. A method for measuring time-varying radar cross section (RCS) of an artery of a patient, comprising:

transmitting RF waves into a tissue of the patient at a first location;

receiving RF wave reflections from at least one artery located within the tissue via at least one sensor;

determining an RF arterial pulse waveform based on the received RF wave reflections, wherein the time-varying radar cross section (RCS) comprises the RF arterial pulse waveform; and

conditioning the RF arterial pulse waveform using at least one radar echo from a specific range adapted to the at least one artery.

67. The method of claim **66**, wherein the at least one sensor comprises a first sensor

and a second sensor, the method further comprising:
sensing, via the first sensor, RF wave reflections corresponding to arterial-pulse-arrival-time (PAT) at a first arterial tree location,
sensing, via the second sensor, signals corresponding to PAT at a second arterial tree location,
determining the PAT at each location, and
determining the difference between the PAT at the two locations so as to determine the an arterial-pulse-travel-time (PTT).

68. The method of claim **66**, further comprising determining a timing of a dicrotic notch of the RF arterial pulse waveform.

69. The method of claim **67**, further comprising determining a timing of a dicrotic notch of the RF arterial pulse waveform.

* * * * *

专利名称(译)	用于确定血压的系统，设备和方法		
公开(公告)号	US20160345845A1	公开(公告)日	2016-12-01
申请号	US15/117168	申请日	2015-02-05
[标]申请(专利权)人(译)	基马医疗科技有限公司		
申请(专利权)人(译)	Kyma酒店MEDICAL TECHNOLOGIES LTD.		
当前申请(专利权)人(译)	Kyma酒店MEDICAL TECHNOLOGIES LTD.		
[标]发明人	RAVID RAFI WEINSTEIN URIEL		
发明人	RAVID, RAFI WEINSTEIN, URIEL		
IPC分类号	A61B5/021 A61B5/00 A61B5/0285 A61B5/024 A61B5/0456		
CPC分类号	A61B5/02125 A61B5/02416 A61B5/6804 A61B5/0285 A61B5/0456 A61B5/021 A61B5/0507 A61B5/1075 A61B5/1076 A61B5/6805 A61B5/6807 A61B5/681 A61B5/6831 A61B5/725		
优先权	61/935958 2014-02-05 US		
外部链接	Espacenet USPTO		

摘要(译)

本公开涉及用于测量患者的动脉的时变雷达截面 (RCS) 的装置，系统和方法，其可以用于确定患者的血压。在一些实施例中，提供了一种装置，其包括用于产生RF波的射频 (RF) 收发器，以及被配置用于定位在患者皮肤上或邻近患者皮肤的至少一个传感器，以及将RF波传输到组织，并接收来自位于组织内的至少一个动脉的RF波反射。该装置还可以包括处理器，该处理器具有在其上操作的计算机指令，其被配置为使处理器基于接收的RF波反射来确定RF动脉脉搏波形。时变雷达截面 (RCS) 包括RF动脉脉搏波形。这可以进而与患者的血压相关。

