



US010335069B2

(12) **United States Patent**
Bechtel et al.

(10) **Patent No.:** **US 10,335,069 B2**
(45) **Date of Patent:** **Jul. 2, 2019**

(54) **OXIMETER PROBE WITH LIGHT WAVELENGTHS TO AVOID SURGICAL DYES**

(71) Applicant: **ViOptix, Inc.**, Fremont, CA (US)

(72) Inventors: **Kate LeeAnn Bechtel**, Pleasant Hill, CA (US); **Lester John Lloyd**, Orinda, CA (US)

(73) Assignee: **ViOptix, Inc.**, Newark, CA (US)

(*) Notice: Subject to any disclaimer, the term of this patent is extended or adjusted under 35 U.S.C. 154(b) by 250 days.

(21) Appl. No.: **14/977,578**

(22) Filed: **Dec. 21, 2015**

(65) **Prior Publication Data**
US 2016/0100781 A1 Apr. 14, 2016

Related U.S. Application Data

(63) Continuation of application No. 13/887,178, filed on May 3, 2013, now Pat. No. 9,216,000.
(Continued)

(51) **Int. Cl.**
A61B 5/1455 (2006.01)
A61B 90/00 (2016.01)
(Continued)

(52) **U.S. Cl.**
CPC **A61B 5/14551** (2013.01); **A61B 5/0059** (2013.01); **A61B 5/0075** (2013.01);
(Continued)

(58) **Field of Classification Search**
None
See application file for complete search history.

(56) **References Cited**

U.S. PATENT DOCUMENTS

4,223,680 A 9/1980 Jobsis
4,286,599 A 9/1981 Hahn et al.
(Continued)

FOREIGN PATENT DOCUMENTS

JP 5261088 10/1993
JP 10216115 A 8/1998
(Continued)

OTHER PUBLICATIONS

Mitnacht, et al., "Methylene Blue Administration is Associated with Decreased Cerebral Oximetry Values," *Anesthesia & Analgesia*, Aug. 2008, vol. 105, No. 2, pp. 549-550.
(Continued)

Primary Examiner — Eric F Winakur
Assistant Examiner — Marjan Fardanesh
(74) *Attorney, Agent, or Firm* — Aka Chan LLP

(57) **ABSTRACT**

A tissue oximetry device utilizes at least three or at least four different wavelengths of light for collection of reflectance data where the different wavelengths are longer than 730 nanometers. The three or four wavelengths are utilized to generate a range of reflectance data suited for accurate determination of oxygenated hemoglobin and deoxygenated hemoglobin concentrations. The relatively long wavelengths decrease optical interference from certain dyes, particularly methylene blue and PVPI, which may be present on tissue being analyzed for viability and further enhance the generation of accurate reflectance data. The wavelengths are 760 nanometers, 810 nanometers, and 850 nanometers, or 760 nanometers, 810 nanometers, 850 nanometers, and 900 nanometers.

54 Claims, 5 Drawing Sheets

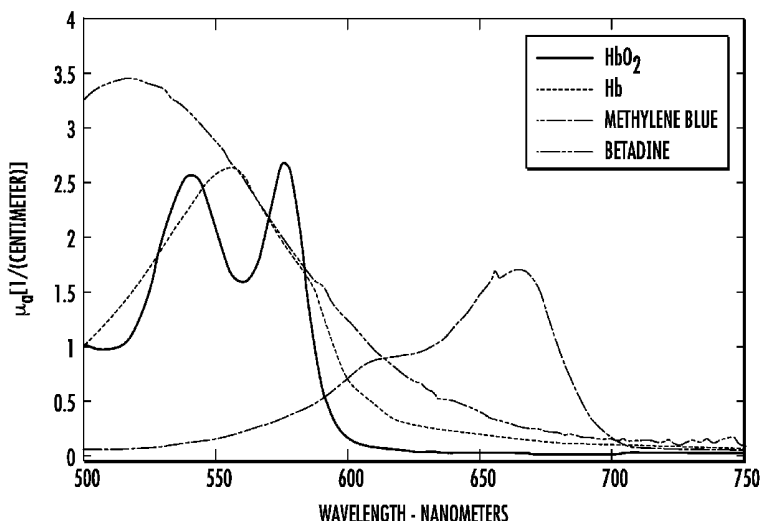

Related U.S. Application Data

(60) Provisional application No. 61/682,146, filed on Aug. 10, 2012, provisional application No. 61/642,393, filed on May 3, 2012, provisional application No. 61/642,389, filed on May 3, 2012, provisional application No. 61/642,395, filed on May 3, 2012, provisional application No. 61/642,399, filed on May 3, 2012.

(51) **Int. Cl.**

A61B 5/1495 (2006.01)
A61B 5/00 (2006.01)
A61M 35/00 (2006.01)
A61B 5/145 (2006.01)
A61B 90/11 (2016.01)
A61B 5/1459 (2006.01)
A61B 90/30 (2016.01)

(52) **U.S. Cl.**

CPC *A61B 5/1455* (2013.01); *A61B 5/1459* (2013.01); *A61B 5/1495* (2013.01); *A61B 5/14546* (2013.01); *A61B 5/14552* (2013.01); *A61B 5/72* (2013.01); *A61B 5/7246* (2013.01); *A61B 5/7282* (2013.01); *A61B 5/74* (2013.01); *A61B 5/742* (2013.01); *A61B 5/7405* (2013.01); *A61B 5/7475* (2013.01); *A61B 90/11* (2016.02); *A61B 90/39* (2016.02); *A61M 35/003* (2013.01); *A61B 2090/065* (2016.02); *A61B 2090/306* (2016.02); *A61B 2090/395* (2016.02); *A61B 2560/0431* (2013.01); *A61B 2560/0475* (2013.01); *A61B 2562/0271* (2013.01); *A61B 2562/166* (2013.01)

(56) **References Cited**

U.S. PATENT DOCUMENTS

5,088,493 A	2/1992	Giannini et al.
5,218,962 A	6/1993	Mannheimer et al.
5,517,301 A	5/1996	Dave
5,517,987 A	5/1996	Tsuchiya
5,690,113 A	6/1997	Sliwa et al.
6,056,692 A	5/2000	Schwartz
6,070,093 A	5/2000	Oosta et al.
6,078,833 A	6/2000	Hueber
6,197,034 B1	3/2001	Gvozdic et al.
6,285,904 B1	9/2001	Weber et al.
6,453,183 B1	9/2002	Walker
6,516,209 B2	2/2003	Cheng et al.
6,549,284 B1	4/2003	Boas et al.
6,587,701 B1	7/2003	Stranc et al.
6,587,703 B2	7/2003	Cheng et al.
6,597,931 B1	7/2003	Cheng et al.
6,708,048 B1	3/2004	Chance
6,735,458 B2*	5/2004	Cheng A61B 5/14546 600/310
6,766,188 B2	7/2004	Soller
6,839,580 B2	1/2005	Zonios et al.
7,247,142 B1	7/2007	Elmandjra et al.
7,254,427 B2	8/2007	Cho et al.
7,344,587 B2	3/2008	Kahn et al.
D567,949 S	4/2008	Lash et al.
7,355,688 B2	4/2008	Lash et al.
D568,479 S	5/2008	Mao et al.
7,657,293 B2	2/2010	Lash et al.
8,798,700 B1	8/2014	Heaton et al.
2002/0019587 A1	2/2002	Cheng et al.
2002/0179094 A1	12/2002	Perlow
2004/0111016 A1	6/2004	Casscells et al.

2004/0260161 A1	12/2004	Melker
2005/0177069 A1	8/2005	Takizawa et al.
2005/0250998 A1	11/2005	Huiku
2005/0277818 A1	12/2005	Myers
2006/0129037 A1	6/2006	Kaufman et al.
2007/0149886 A1	6/2007	Kohls
2008/0015422 A1	1/2008	Wessel
2008/0015424 A1	1/2008	Bernreuter
2008/0139908 A1	6/2008	Kurth
2008/0181715 A1	7/2008	Cohen
2008/0319290 A1	12/2008	Mao et al.
2009/0234209 A1	9/2009	Lash et al.
2009/0275805 A1	11/2009	Lane et al.
2010/0010486 A1	1/2010	Mehta et al.
2011/0028814 A1	2/2011	Petersen et al.
2011/0046458 A1	2/2011	Pinedo et al.
2011/0205535 A1	8/2011	Soller et al.
2011/0224518 A1	9/2011	Tindi et al.
2011/0237911 A1	9/2011	Lamego et al.

FOREIGN PATENT DOCUMENTS

JP	11244268 A	12/1999
JP	2006109964	4/2006
KR	1020000075056	12/2000
KR	1020090016744	2/2009
WO	2011008382	1/2011

OTHER PUBLICATIONS

Alexandrakis, et al., "Accuracy of the Diffusion Approximation in Determining the Optical Properties of a Two-Layer Turbid Medium," *Applied Optics*, vol. 37, No. 31, Nov. 1, 1998, pp. 7403-7409.

Hueber, Dennis et al., "New Optical Probe Designs for Absolute (Self-Calibrating) NIR Tissue Hemoglobin Measurements," in *Proceedings of Optical Tomography and Spectroscopy of Tissue III*, vol. 3597, 618-631(Jan. 1999).

Tseng, et al., "Analysis of a Diffusion-Model-Based Approach for Efficient Quantification of Superficial Tissue Properties," *Optics Letters*, vol. 35, No. 22, Nov. 15, 2010, pp. 3739-3741.

Tseng, et al., "In Vivo Determination of Skin Near-Infrared Optical Properties Using Diffuse Optical Spectroscopy," *Journal of Biomedical Optics*, vol. 13(1), 014016, Jan./Feb. 2008, pp. 1-7.

Seo, et al., "Perturbation and Differential Monte Carlo Methods for Measurement of Optical Properties in a Layered Epithelial Tissue Model," *Journal of Biomedical Optics*, vol. 12(1), 014030, Jan./Feb. 2007, pp. 1-15.

Nichols, et al., "Design and Testing of a White-Light, Steady-State Diffuse Reflectance Spectrometer for Determination of Optical Properties of Highly Scattering Systems," *Applied Optics*, vol. 36, No. 1, Jan. 1, 1997, pp. 93-104.

Kienle, et al., "Spatially Resolved Absolute Diffuse Reflectance Measurements for Noninvasive Determination of the Optical Scattering and Absorption Coefficients of Biological Tissue," *Applied Optics*, vol. 35, No. 13, May 1, 1996, pp. 2304-2314.

Fawzi, et al., "Determination of the Optical Properties of a Two-Layer Tissue Model by Detecting Photons Migrating at Progressively Increasing Depths," *Applied Optics*, vol. 42, No. 31, Nov. 1, 2003, pp. 6398-6411.

Farrell, et al., "Influence of Layered Tissue Architecture on Estimates of Tissue Optical Properties Obtained from Spatially Resolved Diffuse Reflectometry," *Applied Optics*, vol. 37, No. 10, Apr. 1, 1998, pp. 1958-1972.

Dam, et al., "Determination of Tissue Optical Properties from Diffuse Reflectance Profiles by Multivariate Calibration," *Applied Optics*, vol. 37, No. 4, Feb. 1, 1998, pp. 772-778.

Cen, et al., "Optimization of Inverse Algorithm for Estimating the Optical Properties of Biological Materials Using Spatially-Resolved Diffuse Reflectance," *Inverse Problems in Science and Engineering*, vol. 18, No. 6, Sep. 2010, pp. 853-872.

* cited by examiner

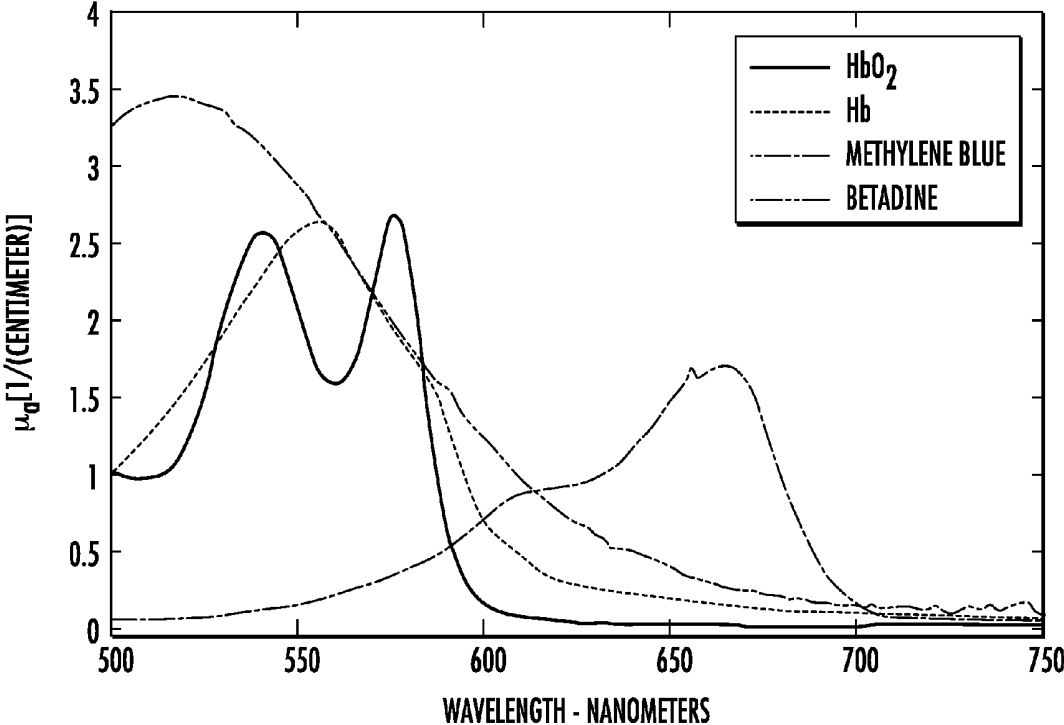

FIG. 1

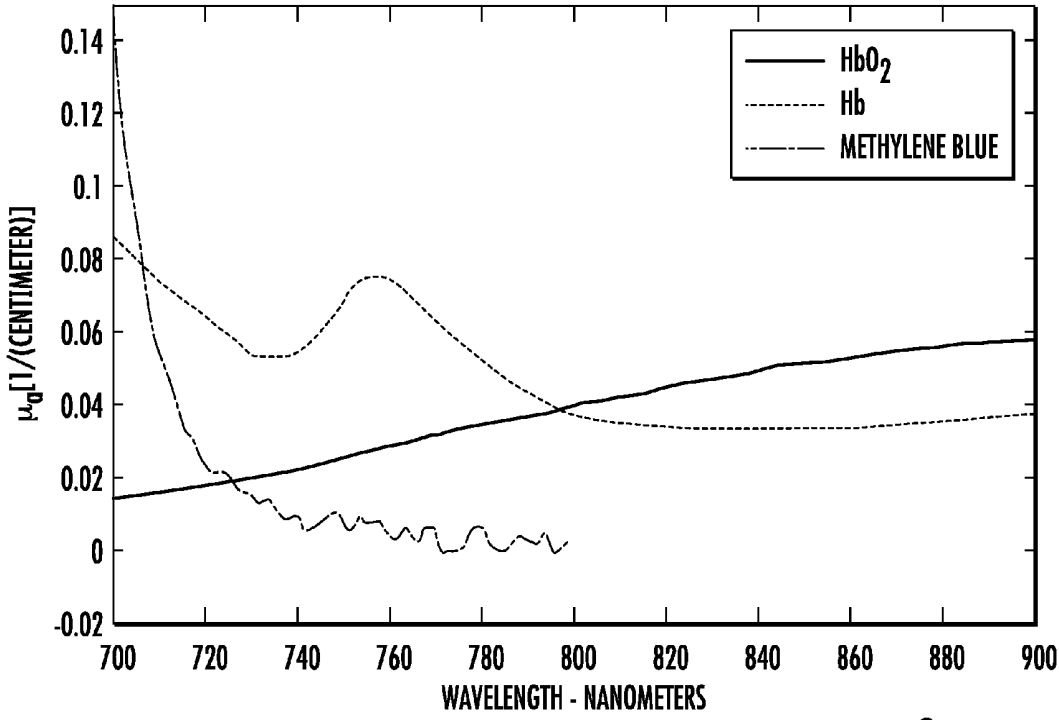
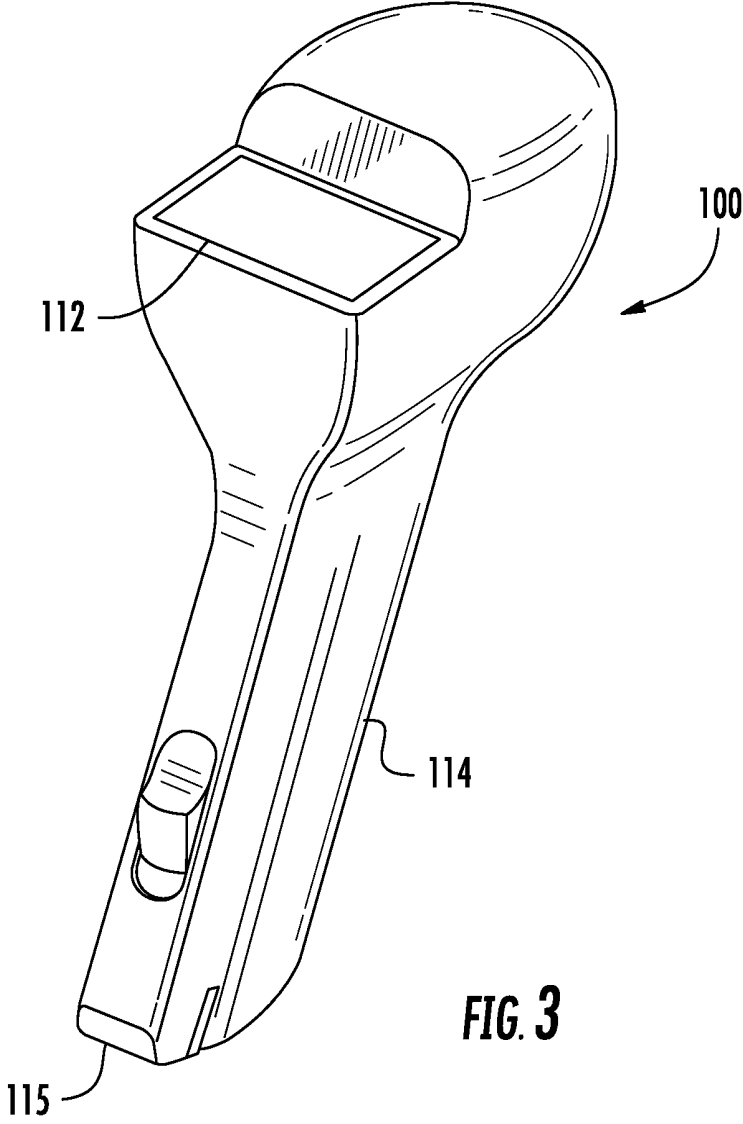

FIG. 2



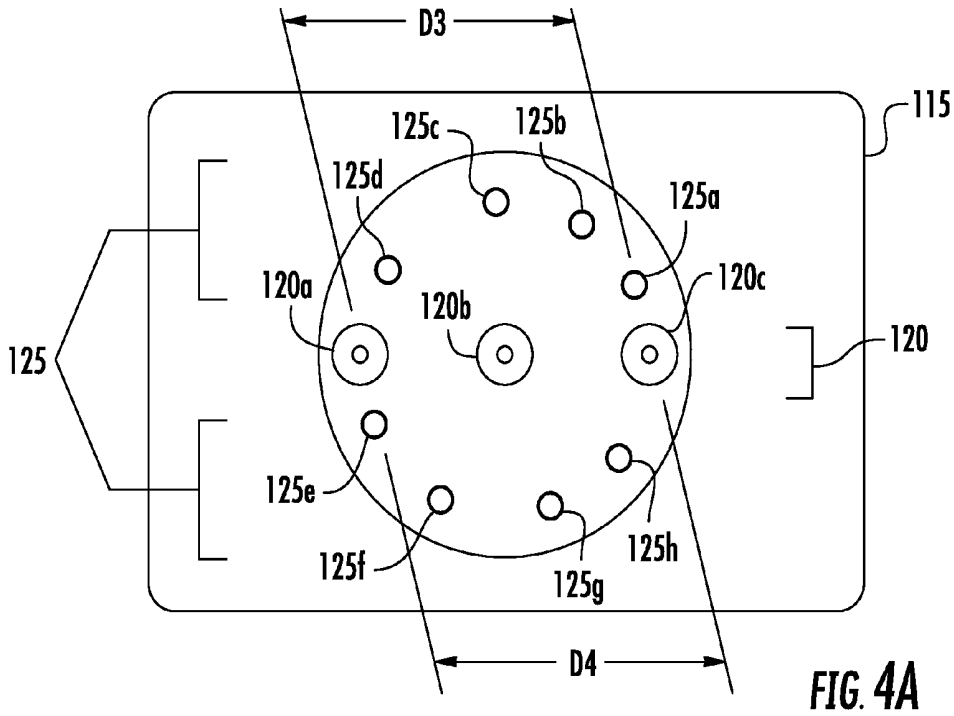

FIG. 4A

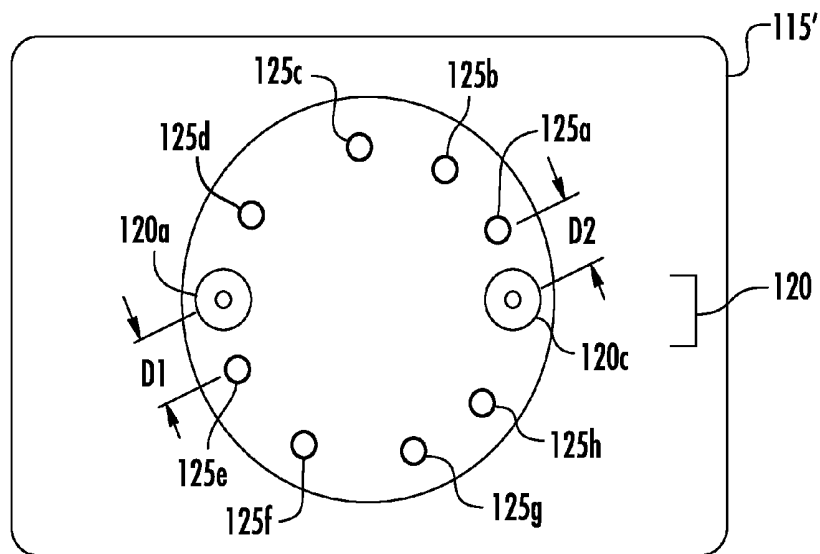

FIG. 4B

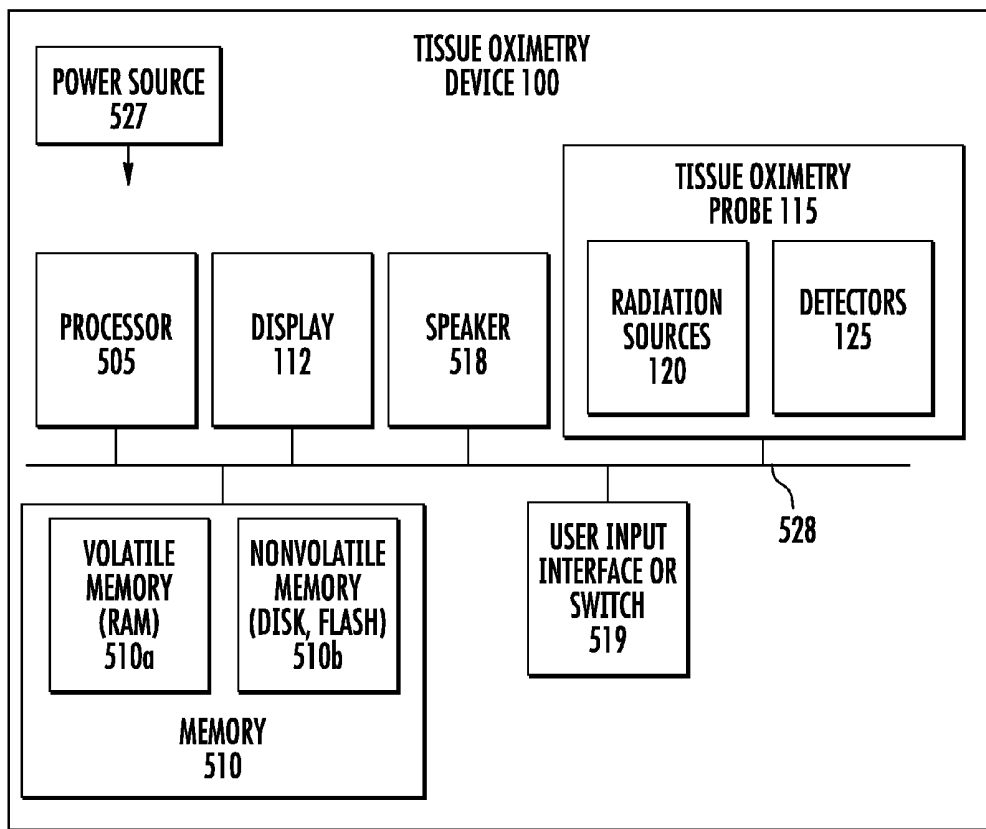

FIG. 5

**OXIMETER PROBE WITH LIGHT
WAVELENGTHS TO AVOID SURGICAL
DYES**

CROSS-REFERENCE TO RELATED
APPLICATIONS

This patent application is a continuation of U.S. patent application Ser. No. 13/887,178, filed May 3, 2013, issued as U.S. Pat. No. 9,216,000 on Dec. 22, 2015, which claims the benefit of U.S. provisional patent applications 61/642,389, 61/642,393, 61/642,395, and 61/642,399, filed May 3, 2012, and 61/682,146, filed Aug. 10, 2012. These applications are incorporated by reference along with all other references cited in this application.

BACKGROUND OF THE INVENTION

The present invention relates generally to optical systems that monitor oxygen levels in tissue. More specifically, the present invention relates to optical probes that include sources and detectors on sensor heads of the optical probes for emitting and detecting light.

Oximeters are medical devices used to measure oxygen saturation of tissue in humans and living things for various purposes. For example, oximeters are used for medical and diagnostic purposes in hospitals and other medical facilities (e.g., surgery, patient monitoring, or ambulance or other mobile monitoring for, e.g., hypoxia); sports and athletics purposes at a sports arena (e.g., professional athlete monitoring); personal or at-home monitoring of individuals (e.g., general health monitoring, or personal training for a marathon); and veterinary purposes (e.g., animal monitoring).

Pulse oximeters and tissue oximeters are two types of oximeters that operate on different principles. A pulse oximeter requires a pulse in order to function. A pulse oximeter typically measures the absorbance of light due to the pulsing arterial blood. In contrast, a tissue oximeter does not require a pulse in order to function, and can be used to make oxygen saturation measurements of a tissue flap that has been disconnected from a blood supply.

Human tissue, as an example, includes a variety of molecules that can interact with light via scattering or absorption (e.g., via light-absorbing chromophores). Such chromophores include oxygenated and deoxygenated hemoglobins, melanin, water, lipid, and cytochrome. Oxygenated and deoxygenated hemoglobins are the most dominant chromophores in the spectrum range of 600 nanometers to 900 nanometers. Light absorption differs significantly for oxygenated and deoxygenated hemoglobins at certain wavelengths of light. Tissue oximeters can measure oxygen levels in human tissue by exploiting these light-absorption differences.

Despite the success of existing oximeters, there is a continuing desire to improve oximeters by, for example, improving measurement accuracy; reducing measurement time; lowering cost; reducing size, weight, or form factor; reducing power consumption; and for other reasons, and any combination of these.

In particular, assessing a patient's oxygenation state is important as it is an indicator of the state of the patient's health. Thus, oximeters are often used in clinical settings, such as during surgery and recovery, where it may be suspected that the patient's tissue oxygenation state is unstable. For example, during surgery, oximeters should be able to quickly deliver accurate oxygen saturation measurements under a variety of nonideal conditions. While existing

oximeters have been sufficient for post-operative tissue monitoring where speed of measurement is less critical, existing oximeters fluctuate substantially and give inaccurate saturation measurements when used during surgery where various elements can interfere with accurate reading, such as if the oximeter comes in contact with blood.

Therefore, there is a need for improved tissue oximetry probes and methods of making measurements using these probes.

BRIEF SUMMARY OF THE INVENTION

A tissue oximetry device utilizes at least two different wavelengths of light for collection of reflectance data where the wavelengths are above 700 nanometers. Utilizing two, three, or four wavelengths generates a range of data that is suited for accurate determination of oxygenated hemoglobin and deoxygenated hemoglobin concentrations.

According to one embodiment, a tissue oximetry device includes a processor; a memory coupled to the processor; and a plurality of light sources. The light sources are controlled by the processor, and generate and emit at least two wavelengths of light longer than 700 nanometers. The tissue oximetry device further includes a plurality of detectors configured to be controlled by the processor. The processor is configured to: control the plurality of light sources to generate and emit the light into tissue, control the plurality of detectors to detect the light subsequent to reflection of the light from the tissue, control the plurality of detectors to generate reflectance data for the tissue based on detection of the light by the plurality of detectors, and determine the oxygen saturation for the tissue based on the reflectance data.

According to one specific embodiment, the at least two wavelengths are approximately 760 nanometers and 850 nanometers. According to an alternative specific embodiment, the plurality of light sources is configured to generate and emit at least three wavelengths of light having wavelengths of 760 nanometers, 810 nanometers, and 850 nanometers. According to another alternative specific embodiment, the plurality of light sources is configured to generate and emit at least four wavelengths of light having wavelengths of approximately 760 nanometers, 810 nanometers, 850 nanometers, and 900 nanometers.

According to another embodiment, a tissue oximetry device includes a processor; a memory coupled to the processor; and a plurality of light sources that are controlled by the processor. The light sources are configured to generate and emit at least two wavelengths of light that are longer than wavelengths of primary absorption peaks of methylene blue. The tissue oximetry device further includes a plurality of detectors configured to be controlled by the processor. The processor is configured to: control the plurality of light sources to generate and emit the light into tissue; control the plurality of detectors to detect the light subsequent to reflection of the light from the tissue; control the plurality of detectors to generate reflectance data for the tissue based on detection of the light by the plurality of detectors; and determine the oxygen saturation for the tissue based on the reflectance data.

These relatively long wavelengths tend to decrease optical interference with certain dyes, particularly methylene blue and povidone-iodine (PVPI, e.g., Betadine® of Purdue Products L.P. of Stamford, Conn.), which may be present in tissue being analyzed for viability, and further enhances the generation of accurate reflectance data. The wavelengths also avoid gentian violet, which is often used in tissue

marking pens. The wavelengths utilized by the tissue oximetry device are outside of the peak absorptive ranges of methylene blue, gentian violet, and PVPI. Therefore, relatively accurate reflectance data may be acquired in an increased number of surgical situations than was acquired by tissue oximetry device utilizing other wavelengths. Further, the use of these particular two, three, or four different wavelengths provides sufficient reflectance data to solve the two-variable, three-variable, or four-variable relations from which oxygenated hemoglobin and deoxygenated hemoglobin concentrations can be determined, depending on how many additional tissue chromophores are included (e.g., melanin, or others). The utilization of optimal probing wavelengths improves tissue oximetry device performance in intraoperative situations involving dyes as compared to the tissue oximetry devices considered to be prior art.

Other objects, features, and advantages of the present invention will become apparent upon consideration of the following detailed description and the accompanying drawings, in which like reference designations represent like features throughout the figures.

BRIEF DESCRIPTION OF THE DRAWINGS

FIG. 1 is an absorption graph that shows the absorption coefficient of methylene blue and PVPI at wavelengths ranging from 500 nanometers to just below 750 nanometers and shows the predominant absorption of wavelengths below 700 nanometers for methylene blue.

FIG. 2 is an absorption graph that shows the absorption coefficient of methylene blue at wavelengths ranging from 700 nanometers to 900 nanometers.

FIG. 3 is a simplified image of a tissue oximetry device according to one embodiment.

FIG. 4A is a simplified end view of the tissue oximetry probe according to one embodiment.

FIG. 4B is a simplified end view of the tissue oximetry probe according to an alternative embodiment.

FIG. 5 is a block diagram of the tissue oximetry device according to one embodiment.

DETAILED DESCRIPTION OF THE INVENTION

Colored dyes often are present on or have been absorbed by the tissue regions that clinicians wish to check for viability. Methylene blue is one dye that is often used for sentinel lymph node biopsies, which are often performed during the same surgical session as a mastectomy in order to determine the degree to which cancerous tissue may have spread. Therefore, methylene blue can be present in the tissue being analyzed for viability for reconstruction or the like. Methylene blue absorbs light readily in the 500 nanometer to 700 nanometer range with the absorption tailing off at about 730 nm.

Povidone-iodine (PVPI, e.g., Betadine® of Purdue Products L.P. of Stamford, Conn.) is an orange dye that is often used as an antiseptic prior to making surgical incisions and may therefore also be present on tissue of interest. Similar to methylene blue, PVPI absorbs light readily in the 500 nanometer to 700 nanometer range, however to a lesser degree than methylene blue. Further, gentian violet is a dye that is often used in tissue marking pens, such as the pens used by plastic surgeons and may therefore be present on tissue of interest.

FIGS. 1 and 2 are absorption graphs that show the absorption coefficient μ_a of methylene blue at wavelengths

ranging from 500 nanometers to 900 nanometers. FIG. 1 also shows the predominant absorption by methylene blue of wavelengths below 700 nanometers and shows the primary absorption peaks of methylene blue centered at about 600 nanometers and 660 nanometers. FIG. 1 also shows the absorption coefficient μ_a of PVPI at wavelengths ranging from 500 nanometers to just below 750 nanometers. FIG. 1 also shows the predominant absorption by PVPI of wavelengths below 650 nanometers and shows the primary absorption peak of PVPI centered at about 510 nanometers.

The presence of methylene blue, PVPI, or other dyes can interfere with the determinations of tissue viability. For example, surgeons may use tissue oximetry devices for determining the viability of tissue, and dyes present on the tissue can absorb the wavelengths used by the tissue oximetry devices for providing tissue viability information.

FIG. 3 is a simplified image of a tissue oximetry device **100** according to one embodiment. Tissue oximetry device **100** is configured to make tissue oximetry measurements, such as intraoperatively and postoperatively. In an implementation, the tissue oximetry device is handheld and can make tissue oximetry measurements and display these measurements, without needing to connect to another external component either via a cable or wirelessly. The electronics to make measurements and calculations is contained entirely within the housing of the tissue oximetry device. The tissue oximetry device is a standalone handheld tissue oximeter device, without a cable or wireless connection.

Tissue oximetry device **100** may be a handheld device that includes a tissue oximetry probe **115** (also sometimes referred to as a sensor head), which may be positioned at an end of a sensing arm **114**. Tissue oximetry device **100** is configured to measure the oxygen saturation of tissue by emitting light, such as red and near-infrared light, from tissue oximetry probe **115** into tissue, and collecting light reflected from the tissue at the tissue oximetry probe.

Tissue oximetry device **100** may include a display **112** or other notification device that notifies a user of oxygen saturation measurements made by the tissue oximetry device. While tissue oximetry probe **115** is described as being configured for use with tissue oximetry device **100**, which is a handheld device, tissue oximetry probe **115** may be used with other tissue oximetry devices, such as a modular tissue oximetry device where the tissue oximetry probe is at the end of a cable device that connects to a base unit. The cable device might be a disposable device that is configured for use with a single patient and the base unit might be a device that is configured for repeated use. Such modular tissue oximetry devices are well understood by those of skill in the art and are not described further.

FIG. 4A is a simplified end view of tissue oximetry probe **115** according to one embodiment. Tissue oximetry probe **115** is configured to contact tissue (e.g., a patient's skin) for which a tissue oximetry measurement is to be made. Tissue oximetry probe **115** includes a set of light sources **120** (generally light sources **120**) and includes a set of detectors **125** (generally detectors **125**). The set of light sources **120** may include two or more light sources. According to the embodiment shown in FIG. 4A, tissue oximetry probe **115** includes three light sources **120a**, **120b**, and **120c**, but may alternatively include two light sources, such as light sources **120a** and **120c** where light source **120b** is omitted. Additional light sources (not shown) can be added. FIG. 4B is a simplified end view of a tissue oximetry probe **115'** according to an embodiment where the tissue oximetry probe includes the two light sources **120a** and **120c**, but does not

include light source **120b**. Aside from the different number of light sources, tissue oximetry probes **115** and **115'** are substantially similar.

The set of detectors **125** may include eight detectors **125a**, **125b**, **125c**, **125d**, **125e**, **125f**, **125g**, and **125h** as shown, but may include more or fewer detectors. Detectors **125** are positioned with respect to outer light sources **120a** and **120c** such that eight or more (e.g., fourteen) unique source-to-detector distances are created. The shortest source-to-detector distances may be the same. For example, the shortest source-to-detector distance **D1** between light source **120a** and detector **125e**, and the shortest source-to-detector distance **D2** between light source **120c** and detector **125a** may be the same. It follows that the source-to-detector distance **D3** between light source **120a** and detector **125a**, and the source-to-detector distance **D4** between light source **120c** and detector **125e** may also be the same. The source-to-detector distances **D3** and **D4** are the longest source-to-detector distance for light sources **120a** and **120c**. With the exception of the shortest source-to-detector distance and the longest source-to-detector distance for light sources **120a** and **120c**, the source-to-detector distances for light sources **120a** and **120c** may be unique. As described above, tissue oximetry probe **115** may have fourteen unique source-to-detector distances that allow for fourteen reflectance data points to be collected by detectors **125** from each wavelength of light emitted from light sources **120**. As described in further detail below, each light source **120** is configured to generate and emit a number of wavelengths.

Detectors **125** are solid state detectors and may be mounted on a printed circuit board (PCB, not shown), which routes various signal to and from the detectors. Further, detectors **125** may be combined devices or discrete devices.

While the tissue oximetry probes **115** and **115'** are described above as having circularly arranged detectors, the detectors may be positioned in other arrangements, such as linear, triangular, rectangular, square, and others. In some embodiments, the light sources may also be alternatively arranged, such as in a triangular arrangement, a rectangular arrangement, and others.

In a specific implementation, detectors **125** are positioned with respect to outer light sources **120a** and **120c** such that four or more (e.g., fourteen) unique source-to-detector distances are created. With greater numbers of source-to-detector distances, this can be used to obtain greater accuracy, faster calibration, and redundancy (when duplicate source-to-detector distances are provided). At least two source-to-detectors distances are about 1.5 millimeters or less (e.g., 0.5 millimeters up to about 1.7 millimeters), and at least two more two source-to-detectors distances are about 2.5 millimeters or greater (e.g., 1.5 millimeters up to about 3.2 millimeters).

In other words, a first source-to-detector distance is about 1.5 millimeters or less. A second source-to-detector distance is about 1.5 millimeters or less. A third source-to-detector distance is about 2.5 millimeters or greater. A fourth source-to-detector distance is about 2.5 millimeters or greater. There can be various numbers of sources and detector arrangements to obtain these four source-to-detector distances, such as one source and four detectors, two sources and two detectors, one detector and four sources, or other arrangements and combinations.

For example, an implementation includes at least two sources and at least two detectors, where a maximum distance between a source and a detector is about 4 millimeters (or about 5 millimeters). At least two source-to-

detector are about 2.5 millimeters or greater. At least two source-to-detector distances are about 1.5 millimeters or less.

When a greater number of sources and detectors are used, greater numbers of source-to-detector distances are available. As discussed, these can be used to provide greater accuracy, faster calibration, or redundancy, or a combination. The arrangement of the sources and detectors can be in circular pattern, such as at points along the arc of a circle with radius (e.g., 4 millimeters, or 5 millimeters). In an implementation, a tolerance of the detector or source positions on the arc is within 10 microns of the arc curve. In other implementations, the tolerance is within about 0.5 millimeters.

Wavelengths Generated and Emitted From the Light Sources

Each light source **120** may include a fiber optic cable and one or more light emitting diodes (LEDs) or laser diodes (generally wavelength sources) that transmit generated light into the fiber optic cable. For example, each light source **120** may include two or more wavelength sources that generate two or more substantially unique wavelengths. The wavelengths may all be longer than 730 nanometers, e.g., in the red and near infrared.

According to an embodiment where each light source **120** includes two wavelength sources, the wavelength sources may be configured to generate and emit wavelengths of approximately 760 nanometers (e.g., +/-10 nanometers), and 850 nanometers (e.g., +/-20 nanometers). According to an embodiment where each light source **120** includes three wavelength sources, the wavelength sources may be configured to generate and emit wavelengths of approximately 760 nanometers (e.g., +/-10 nanometers), 810 nanometers (e.g., +/-10 nanometers), and 850 nanometers (e.g., +/-20 nanometers). According to another embodiment, where each light source **120** includes four wavelength sources, the wavelength sources may be configured to emit wavelengths of approximately 760 nanometers (e.g., +/-10 nanometers), 810 nanometers (e.g., +/-10 nanometers), 850 nanometers (e.g., +/-20 nanometers), and 900 nanometers (e.g., +/-20 nanometers). Additional and/or alternative wavelengths may be utilized by tissue oximetry device **100**.

Use of the described wavelengths by tissue oximetry device **100** tends to decrease the fraction of emitted light that can be absorbed by methylene blue, gentian violet, and PVPI, and thereby increases the fraction of light that can be scattered or absorbed by intrinsic tissue elements and generates accurate reflectance data. Accurate reflectance data is necessary in order to extract the optical properties of tissue from which the concentrations of oxygenated and deoxygenated hemoglobin can be derived.

For the foregoing described wavelengths, tissue scattering is relatively low and light penetrates farther into tissue than shorter wavelengths. Further, the foregoing described wavelengths are on both sides of an oxygenated-deoxygenated hemoglobin spectral crossing point called an isosbestic point, which is 810 nanometers for hemoglobin. As such, when one chromophore (e.g., oxygenated hemoglobin) has high absorption, the other chromophore (e.g., deoxygenated hemoglobin) then has low absorption and vice versa. The tissue oximetry device's utilization of wavelengths surrounding the isosbestic point provides for relatively improved statistics for oxygen saturation determinations.

In at least one of the foregoing described embodiments, tissue oximetry device **100** utilizes a wavelength at approximately the isosbestic point, at 810 nanometers. At the isosbestic point the absorption of the 810 nanometer wave-

length for oxygenated hemoglobin and deoxygenated hemoglobin are equivalent and therefore provides a stable reference point in the reflectance data generated by detectors 125. Relatively longer wavelengths, such as the 900 nanometer wavelength of at least one embodiment allows for distinguishing between the absorption curve for deoxygenated hemoglobin from the absorption curve for melanin.

Tissue Oximetry Device Circuit

FIG. 5 is a block diagram of tissue oximetry device 100 according to one embodiment. Tissue oximetry device 100 according to the embodiment shown in FIG. 5 includes display 112, a processor 505, a memory 510, a speaker 518, one or more user-selection devices 519 (e.g., one or more switches for initiating oxygen saturation measurements), the set of light sources 120, the set of detectors 125, and a power source (e.g., a battery) 527. The foregoing listed components may be linked together via a bus 528, which may be the system bus architecture of tissue oximetry device 100. Although this figure shows one bus that connects to each component, the busing is illustrative of any interconnection scheme serving to link these components or other components included in tissue oximetry device 100 subsystems. For example, speaker 518 (e.g., an alternative device for notifying a user of oxygen saturation measurements) could be connected to a subsystem through a port or have an internal direct connection to processor 516. Further, the components described are housed in a mobile housing (see FIG. 1) of tissue oximetry device 100 according to at least one embodiment.

Processor 505 may include a microprocessor, a microcontroller, control logic, a multi-core processor, or the like. Further, processor 505 may control turning on and turning off the wavelength sources as described below. Memory 510 may include a variety of memories, such as a volatile memory 510a (e.g., a RAM), a nonvolatile memory 519b (e.g., a disk, Flash memory, electrically erasable memory, PROM, and others). Memory 510 may collect and store reflectance data generated by detectors 125. Different implementations of tissue oximetry device 100 may include any number of the listed components, in any combination or configuration, and may also include other components not shown.

Power source 127 can be a battery, such as a disposable battery. Disposable batteries are discarded after their stored charge is expended. Some disposable battery chemistry technologies include alkaline, zinc carbon, or silver oxide. The battery has sufficient stored charge to allow use of the handheld device for several hours. After use, the handheld unit is discarded.

In other implementations, the battery can also be rechargeable where the battery can be recharged multiple times after the stored charge is expended. Some rechargeable battery chemistry technologies include nickel cadmium (NiCd), nickel metal hydride (NiMH), lithium ion (Li-ion), and zinc air. The battery can be recharged, for example, via an AC adapter with cord that connects to the handheld unit. The circuitry in the handheld unit can include a recharger circuit (not shown). Batteries with rechargeable battery chemistry may be sometimes used as disposable batteries, where the batteries are not recharged but disposed of after use.

Use of Wavelengths for Optical Probing.

Oxygenated and deoxygenated hemoglobin concentrations, from which oxygen saturation can be calculated, can be related to the absorption coefficient μ_a of a region of tissue for a given wavelength of light. In some cases, a simple relationship is used for calculation where the absorp-

tion coefficient is assumed to depend only on the concentrations of oxygenated and deoxygenated hemoglobin. However, melanin and water present in tissue can also absorb incident light so this simple relationship may be insufficient for highly accurate concentration calculations, as absorption from water and melanin may be incorrectly attributed to oxygenated or deoxygenated hemoglobin. A relationship between the absorption coefficient and the concentrations of oxygenated hemoglobin (HbO₂), deoxygenated hemoglobin (Hb), water (H₂O), and melanin (mel) may be:

$$\mu_a = 2.303(\epsilon_{HbO_2}[HbO_2] + \epsilon_{Hb}[Hb] + \epsilon_{H_2O}[H_2O] + \epsilon_{mel}[mel])$$

where $\epsilon_{species}$ denotes the molar absorptivity of a given species and bracketed quantities indicate concentration values.

The shape of a reflectance curve (generated by plotting the intensity of diffusely reflected or re-emitted light) can be analyzed to obtain the absorption and scattering coefficients for a given region of tissue. There are four unknown concentrations (i.e., [HbO₂], [Hb], [H₂O], and [mel]) in the above relationship that correspond to the absorption coefficient. Once the absorption coefficient is determined for a given wavelength, the relationship becomes an equation of four unknown variables. However, since the concentrations of oxygenated and deoxygenated hemoglobin, water, and melanin should not vary considerably over the course of a probe measurement, probing the tissue with four different wavelength emitted by the wavelength sources can provide four values for μ_a , which can be used to determine the four relevant concentrations in the expression for μ_a . That is, a system of four equations with four unknown variables can be solved, as is well understood. From the determined concentrations of oxygenated hemoglobins [HbO₂] and deoxygenated hemoglobins [Hb], the oxygen saturation of tissue can be determined.

According to the embodiment where three wavelengths are emitted by the wavelength sources, the contributions from water, melanin, and other light absorbers can be combined into a single term and expressed as:

$$\mu_a = 2.303(\epsilon_{HbO_2}[HbO_2] + \epsilon_{Hb}[Hb] + \epsilon_{H_2O, mel}[H_2O, mel])$$

If three absorption coefficients μ_a are determined for the three wavelengths, then the three relevant concentrations for [HbO₂], [Hb], and [H₂O, mel]) can be determined, and the oxygen saturation can again be determined from the determined concentrations of oxygenated and deoxygenated hemoglobins. The absorption coefficients may be determined from the reflectance data by a variety of methods, such as fitting the reflectance data to one or more predetermined reflectance curves, where each predetermined reflectance curve represents a unique absorption coefficient. The absorption coefficients may alternatively be determined by vector multiplication with the net analyte signal, which is described in U.S. Pat. No. 6,597,931, titled "System and Method for Absolute Oxygen Saturation," and is incorporated by reference.

Wavelength Source Control

The wavelength sources may be cycled on and off at a variety of frequencies. For example, the wavelength sources may be turned on in sequence with one wavelength source on at any one time. The wavelength sources may be cycled at 30 hertz. Additionally each wavelength source may be modulated at a variety of frequencies in order to reject ambient light. For example, each wavelength source may be individually modulated at 2.5 kilohertz. Further, the wavelength sources may be individually cycled in a specific order.

Detectors **125** may be substantially continuously monitored as the wavelength sources are cycled. Processor **505** may control the cycle order of the wavelength sources. Based on the cycle order, the reflectance data collected by detectors **125** may be appropriately categorized according to wavelength based on the known cycling of the wavelength sources on and off. The reflectance data may be stored in memory **510** for use by processor **505** in determining the oxygenated and deoxygenated hemoglobin concentrations and to further determine the oxygen saturation of tissue being probed.

This description of the invention has been presented for the purposes of illustration and description. It is not intended to be exhaustive or to limit the invention to the precise form described, and many modifications and variations are possible in light of the teaching above. The embodiments were chosen and described in order to best explain the principles of the invention and its practical applications. This description will enable others skilled in the art to best utilize and practice the invention in various embodiments and with various modifications as are suited to a particular use. The scope of the invention is defined by the following claims.

The invention claimed is:

1. A method comprising:
 providing a sensor head for a tissue oximetry device comprising:
 detectors arranged on the sensor head; and
 first and second light source structures positioned in a line on the sensor head, wherein
 the first source structure is configured to emit at least a first wavelength of light longer than about 730 nanometers,
 the second source structure is configured to emit at least a second wavelength of light longer than about 730 nanometers,
 a first detector of the detectors is a first distance from the first light source,
 a second detector of the detectors is a second distance from the second light source,
 a third detector of the detectors is a third distance from the first light source,
 no detector is positioned between the first detector and the third detector, the line passes between the first detector and the third detector, the line is closer to the first detector than the third detector, and the first, second, and third detectors are not on the line,
 the first distance and the second distance are equal, and the first distance and the third distance are not equal; and
 enclosing a processing module in a housing coupled to the sensor head, wherein the processing module is adapted for determining an oxygen saturation value for a tissue to be measured using the first wavelength of light from the first source structure and the second wavelength of light from the second source structure emitted into the tissue and corresponding reflected light received by at least two of the detectors.

2. The method of claim **1** wherein the determining an oxygen saturation value for a tissue comprises:
 receiving digital reflectance data for the reflected light received by the at least two of the detectors;
 calculating absorption coefficients using the digital reflectance data;
 solving a set of reflection coefficient equations for the tissue to be measured using the absorption coefficients to determine concentration values of at least oxygenated hemoglobin and deoxygenated hemoglobin; and

determining an oxygen saturation value for the tissue using the concentration values of oxygenated hemoglobin and deoxygenated hemoglobin.

3. The method of claim **1** wherein the first wavelength of light is at least one of 760 nanometers, 810 nanometers, 850 nanometers, or 900 nanometers.

4. The method of claim **1** wherein the first wavelength of light is at least one of 760 nanometers, 810 nanometers, or 850 nanometers, and the second wavelength of light is at least one of 760 nanometers, 810 nanometers, 850 nanometers, or 900 nanometers.

5. The method of claim **1** wherein the first and second source structures are coupled via optical fibers to light emitting diodes, and the first, second, and third detector structures comprise photodetectors.

6. The method of claim **1** wherein the detectors are arranged in a circle.

7. The method of claim **1** wherein a fourth distance is between the first and second source structures, and the fourth distance is greater than the first distance, is greater than the second distance, and is greater than the third distance.

8. The method of claim **7** wherein the first detector is symmetrically positioned about a point on the first line with respect to the second detector.

9. The method of claim **8** wherein a fourth detector of the detectors is a fifth distance from the first light source, and the third detector is symmetrically positioned about the point on the first line with respect to the fourth detector.

10. The method of claim **1** wherein the first and second source structures are the only source structures on the sensor head.

11. The method of claim **1** wherein a second line between the first and second detectors does not pass through the first source structure and does not pass through the second source structure.

12. The method of claim **11** wherein a third line between the first and third detectors does not pass through the first source structure and does not pass through the second source structure.

13. The method of claim **12** wherein a fourth line between the second and third detectors does not pass through the first source structure and does not pass through the second source structure.

14. The method of claim **1** wherein a second line is between the first source structure and the first detector, a first angle is between the line and the second line, and the first angle is less than ninety degrees.

15. The method of claim **14** wherein a third line is between the first source structure and the second detector, a second angle is between the line and the third line, and the second angle is less than ninety degrees.

16. The method of claim **15** wherein a fourth line is between the first source structure and the third detector, a third angle is between the line and the fourth line, and the third angle is less than ninety degrees.

17. The method of claim **1** wherein the third detector is a fourth distance from the second source structure,
 a fourth detector of the detectors is a fifth distance from the second source structure,
 a fifth detector of the detectors is a sixth distance from the second source structure,
 the second, third, fourth, and fifth detectors are located on a same side of the line,
 a second line is between the second source structure and the second detector,
 a third line is between the second source structure and the third detector,

a fourth line is between the second source structure and the fourth detector,
 a fifth line is between the second source structure and the fifth detector,
 a first angle is between the line and the second line,
 a second angle is between the line and the third line,
 a third angle is between the line and the fourth line,
 a fourth angle is between the line and the fifth line,
 the first angle is larger than the second angle, is larger than the third angle, and is larger than the fourth angle,
 the second angle is larger than the third angle and is larger than the fourth angle,
 the third angle is larger than the fourth angle, and the second, fourth, fifth, and sixth distances respectively increase as the first, second, third, and fourth angles respectively decrease.

18. A method comprising:
 providing a sensor head for a tissue oximetry device comprising:
 detectors arranged on the sensor head; and
 first and second light source structures positioned in a line on the sensor head, wherein
 the first source structure is configured to emit at least a first wavelength of light longer than about 730 nanometers, and the first wavelength of light is at least one of 760 nanometers, 810 nanometers, or 850 nanometers,
 the second source structure is configured to emit at least a second wavelength of light longer than about 730 nanometers, and the second wavelength of light is at least one of 760 nanometers, 810 nanometers, or 850 nanometers,
 a first detector of the detectors is a first distance from the first light source,
 a second detector of the detectors is a second distance from the second light source,
 a third detector of the detectors is a third distance from the first light source,
 no detector is positioned between the first detector and the third detector, the line passes between the first detector and the third detector, and the line is closer to the first detector than the third detector,
 the first distance and the second distance are equal,
 the first distance and the third distance are not equal,
 a fourth distance is between the first and second source structures,
 the fourth distance is greater than the first distance, is greater than the second distance, and is greater than the third distance, and
 the first and second source structures are coupled via optical fibers to light emitting diodes, and the first, second, and third detector structures comprise photo-detectors; and
 enclosing a processing module in a housing coupled to the sensor head, wherein the processing module is adapted for determining an oxygen saturation value for a tissue to be measured using the first wavelength of light from the first source structure and the second wavelength of light from the second source structure emitted into the tissue and corresponding reflected light received by at least two of the detectors,
 the housing encloses a display, coupled to the processing module, and the display is visible from an exterior of the housing,
 a memory coupled to the processing module, and
 a battery coupled to and supplying power to the processing module and display.

19. The method of claim **18** wherein the determining an oxygen saturation value for a tissue comprises:
 receiving digital reflectance data for the reflected light received by the at least two of the detectors;
 calculating absorption coefficients using the digital reflectance data;
 solving a set of reflection coefficient equations for the tissue to be measured using the absorption coefficients to determine concentration values of at least oxygenated hemoglobin and deoxygenated hemoglobin; and
 determining an oxygen saturation value for the tissue using the concentration values of oxygenated hemoglobin and deoxygenated hemoglobin.

20. The method of claim **18** wherein the detectors are arranged in a circle.

21. The method of claim **18** wherein when the sensor head is placed against the tissue to be measured, the display of the tissue oximetry device faces a user.

22. The method of claim **18** wherein a first light emitting diode is coupled via a first optical fiber to the first source structure, a second light emitting diode is coupled via a second optical fiber to the first source structure, and the first light emitting diode can emit the first wavelength of light of at least two different wavelengths.

23. The method of claim **18** wherein a first light emitting diode is coupled via a first optical fiber to the first source structure, a second light emitting diode is coupled via a second optical fiber to the first source structure, and the first light emitting diode can emit the first wavelength of light of at least four different wavelengths and the at least four wavelengths are longer than wavelengths of primary absorption peaks of methylene blue.

24. The method of claim **18** wherein the first, second, and third detectors are not on the line.

25. The method of claim **18** wherein the first detector is symmetrically positioned about a point on the line with respect to the second detector.

26. The method of claim **25** wherein a fourth detector of the detectors is a fourth distance from the first light source, and the third detector is symmetrically positioned about the point on the line with respect to the fourth detector.

27. The method of claim **18** wherein the first and second source structures are the only source structures on the sensor head.

28. The method of claim **18** wherein a second line between the first and second detectors does not pass through the first source structure and does not pass through the second source structure.

29. The method of claim **28** wherein a third line between the first and third detectors does not pass through the first source structure and does not pass through the second source structure.

30. The method of claim **29** wherein a fourth line between the second and third detectors does not pass through the first source structure and does not pass through the second source structure.

31. The method of claim **18** wherein a second line is between the first source structure and the first detector, a first angle is between the line and the second line, and the first angle is less than ninety degrees.

32. The method of claim **31** wherein a third line is between the first source structure and the second detector, a second angle is between the line and the third line, and the second angle is less than ninety degrees.

33. The method of claim **32** wherein a fourth line is between the first source structure and the third detector, a

third angle is between the line and the fourth line, and the third angle is less than ninety degrees.

34. The method of claim **18** wherein the third detector is a fourth distance from the second source structure, a fourth detector is a fifth distance from the second source structure, a fifth detector is a sixth distance from the second source structure, the second, third, fourth, and fifth detectors are located on a same side of the line, a second line is between the second source structure and the second detector, a third line is between the second source structure and the third detector, a fourth line is between the second source structure and the fourth detector, a fifth line is between the second source structure and the fifth detector, a first angle is between the line and the second line, a second angle is between the line and the third line, a third angle is between the line and the fourth line, a fourth angle is between the line and the fifth line, the first angle is larger than the second angle, is larger than the third angle, and is larger than the fourth angle, the second angle is larger than the third angle and is larger than the fourth angle, the third angle is larger than the fourth angle, and the second, fourth, fifth, and sixth distances respectively increase as the first, second, third, and fourth angles respectively decrease.

35. The method of claim **18** wherein the detectors are not arranged in a circle.

36. A method comprising:

providing a sensor head for a tissue oximetry device comprising:

a plurality of detector structures arranged on the sensor head; and

first and second source structures positioned in a, first line on the sensor head, wherein the first source structure is configured to emit at least a first wavelength of light longer than about 730 nanometers,

the second source structure is configured, to emit at least a second wavelength of light longer than about 730 nanometers,

a first detector of the plurality of detectors is a first distance from the first light source,

a second detector of the plurality of detectors is a second distance from the second light source,

a third detector of the plurality of detectors is a third distance from the first light source,

the first line is between the first detector and the third detector, and the first line is closer to the first detector than the third detector,

the first and second distances are equal,

the first and third distances are not equal,

a second line between the first and second detectors does not pass through the first source structure and does not pass through the second source structure,

a third line between the first and third detectors does not pass through the first source structure and does not pass through the second source structure, and

a fourth line between the second and third detectors does not pass through the first source structure and does not pass through the second source structure; and

enclosing a processing module in a housing coupled to the sensor head, wherein the processing module is adapted for determining an oxygen saturation value for a tissue

to be measured using the first wavelength of light from the first source structure and the second wavelength of light from the second source structure emitted into the tissue and corresponding reflected light received by at least two of the detectors.

37. The method of claim **36** wherein the determining an oxygen saturation value for a tissue comprises:

receiving digital reflectance data for the reflected light received by the at least two of the detector structures; calculating absorption coefficients using the digital reflectance data;

solving a set of reflection coefficient equations for the tissue to be measured using the absorption coefficients to determine concentration values of at least oxygenated hemoglobin and deoxygenated hemoglobin; and determining an oxygen saturation value for the tissue using the concentration values of oxygenated hemoglobin and deoxygenated hemoglobin.

38. The method of claim **36** wherein the detector structures are arranged in a circle.

39. The method of claim **36** wherein the detector structures are not arranged in a circle.

40. The method of claim **36** wherein when the sensor head is placed against the tissue to be measured, a display of the tissue oximetry device faces a user.

41. The method of claim **36** wherein a first light emitting diode is coupled via a first optical fiber to the first source structure, a second light emitting diode is coupled via a second optical fiber to the second source structure, and the first light emitting diode can emit the first wavelength of light of at least two different wavelengths.

42. The method of claim **36** wherein a first light emitting diode is coupled via a first optical fiber to the first source structure, a second light emitting diode is coupled via a second optical fiber to the second source structure, and the first light emitting diode can emit the first wavelength of light of at least four different wavelengths and the at least four wavelengths are longer than wavelengths of primary absorption peaks of methylene blue.

43. The method of claim **36** wherein the first, second, and third detector structures are not on the first line.

44. The method of claim **36** wherein a fourth distance is between the first and second source structures, and the fourth distance is greater than the first distance, is greater than the second distance, and is greater than the third distance.

45. The method of claim **44** wherein the first detector structure is symmetrically positioned about a point on the first line with respect to the second detector structure.

46. The method of claim **45** wherein a fourth detector structure of the plurality of detector structures is a fourth distance from the first source structure, and the third detector structure is symmetrically positioned about the point on the first line with respect to the fourth detector structure.

47. The method of claim **36** wherein the first and second source structures are the only source structures on the sensor head.

48. The method of claim **36** wherein a second line between the first and second detector structures does not pass through the first source structure and does not pass through the second source structure.

49. The method of claim **48** wherein a third line between the first and third detector structures does not pass through the first source structure and does not pass through the second source structure.

15

50. The method of claim 49 wherein a fourth line between the second and third detector structures does not pass through the first source structure and does not pass through the second source structure.

51. The method of claim 36 wherein a second line is between the first source structure and the first detector structure, a first angle is between the first line and the second line, and the first angle is less than ninety degrees.

52. The method of claim 51 wherein a third line is between the first source structure and the second detector structure, a second angle is between the first line and the third line, and the second angle is less than ninety degrees.

53. The method of claim 52 wherein a fourth line is between the first source structure and the third detector structure, a third angle is between the first line and the fourth line, and the third angle is less than ninety degrees.

54. The method of claim 36 wherein the third detector is a fourth distance from the second source structure, a fourth detector structure of the plurality of detector structures is a fifth distance from the second source structure, a fifth detector structure of the plurality of detector structures is a sixth distance from the second source structure,

16

the second, third, fourth, and fifth detectors are located on a same side of the first line,

a second line is between the second source structure and the second detector,

a third line is between the second source structure and the third detector,

a fourth line is between the second source structure and the fourth detector,

a fifth line is between the second source structure and the fifth detector,

a first angle is between the first line and the second line, a second angle is between the first line and the third line, a third angle is between the first line and the fourth line,

a fourth angle is between the first line and the fifth line, the first angle is larger than the second angle, is larger than the third angle, and is larger than the fourth angle,

the second angle is larger than the third angle and is larger than the fourth angle,

the third angle is larger than the fourth angle, and the second, fourth, fifth, and sixth distances respectively increase as the first, second, third, and fourth angles respectively decrease.

* * * * *

专利名称(译)	具有光波长的血氧计探头，以避免手术染料		
公开(公告)号	US10335069	公开(公告)日	2019-07-02
申请号	US14/977578	申请日	2015-12-21
[标]申请(专利权)人(译)	维奥普蒂克斯公司		
申请(专利权)人(译)	VIOPTIX INC.		
当前申请(专利权)人(译)	VIOPTIX INC.		
[标]发明人	BECHTEL KATE LEEANN LLOYD LESTER JOHN		
发明人	BECHTEL, KATE LEEANN LLOYD, LESTER JOHN		
IPC分类号	A61B5/1455 A61B5/1459 A61B90/11 A61B5/145 A61B5/00 A61B5/1495 A61B90/00 A61M35/00 A61B90/30		
CPC分类号	A61B5/14551 A61B5/0075 A61B5/1455 A61B5/1459 A61B5/1495 A61B5/14546 A61B5/14552 A61B5/ /72 A61B5/7246 A61B5/7282 A61B5/74 A61B5/742 A61B5/7405 A61B5/7475 A61B90/11 A61B90/39 A61M35/003 A61B5/0059 A61B2562/166 A61B2090/065 A61B2090/306 A61B2090/395 A61B2560 /0431 A61B2560/0475 A61B2562/0271		
优先权	61/682146 2012-08-10 US 61/642393 2012-05-03 US 61/642389 2012-05-03 US 61/642395 2012-05-03 US 61/642399 2012-05-03 US		
其他公开文献	US20160100781A1		
外部链接	Espacenet		

摘要(译)

组织血氧测定装置利用至少三种或至少四种不同波长的光来收集反射率数据，其中不同波长长于730纳米。利用三个或四个波长产生一系列适合于精确测定氧合血红蛋白和脱氧血红蛋白浓度的反射数据。相对长的波长降低了来自某些染料的光学干扰，特别是亚甲蓝和PVPI，其可能存在于被分析组织的生存力上并进一步增强精确反射率数据的产生。波长为760纳米，810纳米和850纳米，或760纳米，810纳米，850纳米和900纳米。

