



US009693718B2

(12) **United States Patent**
Boyce et al.

(10) **Patent No.:** **US 9,693,718 B2**
(45) **Date of Patent:** **Jul. 4, 2017**

(54) **SYSTEM AND METHOD FOR FACILITATING SENSOR AND MONITOR COMMUNICATION**

(71) Applicant: **COVIDIEN LP**, Mansfield, MA (US)

(72) Inventors: **Robin Boyce**, Pleasanton, CA (US);
Brad Nordstrom, Alameda, CA (US);
Arie Ravid, Rishon-Lezion (IL); **Hui Wang**, San Ramon, CA (US)

(73) Assignee: **Covidien LP**, Mansfield, MA (US)

(*) Notice: Subject to any disclaimer, the term of this patent is extended or adjusted under 35 U.S.C. 154(b) by 0 days.

(21) Appl. No.: **14/613,142**

(22) Filed: **Feb. 3, 2015**

(65) **Prior Publication Data**

US 2015/0150495 A1 Jun. 4, 2015

Related U.S. Application Data

(63) Continuation of application No. 13/747,137, filed on Jan. 22, 2013, now Pat. No. 8,983,566, which is a (Continued)

(51) **Int. Cl.**

A61B 5/1455 (2006.01)
A61B 5/00 (2006.01)

(Continued)

(52) **U.S. Cl.**

CPC *A61B 5/14551* (2013.01); *A61B 5/0002* (2013.01); *A61B 5/01* (2013.01); *A61B 5/02416* (2013.01); *A61B 5/1495* (2013.01); *A61B 5/14552* (2013.01); *A61B 5/6826* (2013.01); *A61B 5/6838* (2013.01); *A61B*

5/742 (2013.01); *A61B 5/7232* (2013.01);
A61B 2562/085 (2013.01)

(58) **Field of Classification Search**

CPC . *A61B 5/14552*; *A61B 5/6826*; *A61B 5/6838*;
A61B 5/7232; *A61B 2562/085*

USPC 600/310-344
See application file for complete search history.

(56) **References Cited**

U.S. PATENT DOCUMENTS

5,357,953 A * 10/1994 Merrick A61B 5/1459
356/39
5,645,059 A * 7/1997 Fein A61B 5/0002
356/41

(Continued)

FOREIGN PATENT DOCUMENTS

JP 2006320731 11/2006
JP 2006320732 11/2006

(Continued)

Primary Examiner — Michael C Stout

(74) *Attorney, Agent, or Firm* — Fletcher Yoder PC

(57) **ABSTRACT**

Embodiments disclosed herein may include an adapter which is capable of converting signals from an oximeter sensor such that the signals are readable by an oximeter monitor. In an embodiment, the adapter is capable of converting signals relating to calibration information from the oximeter sensor. The calibration information may relate to wavelengths of light emitting diodes within the oximeter sensor. In a specific embodiment, the adapter will convert wavelength calibration information in a first form relating to data values stored in a digital memory chip to a second form relating to a resistance value of an expected resistor within the oximeter sensor.

22 Claims, 5 Drawing Sheets

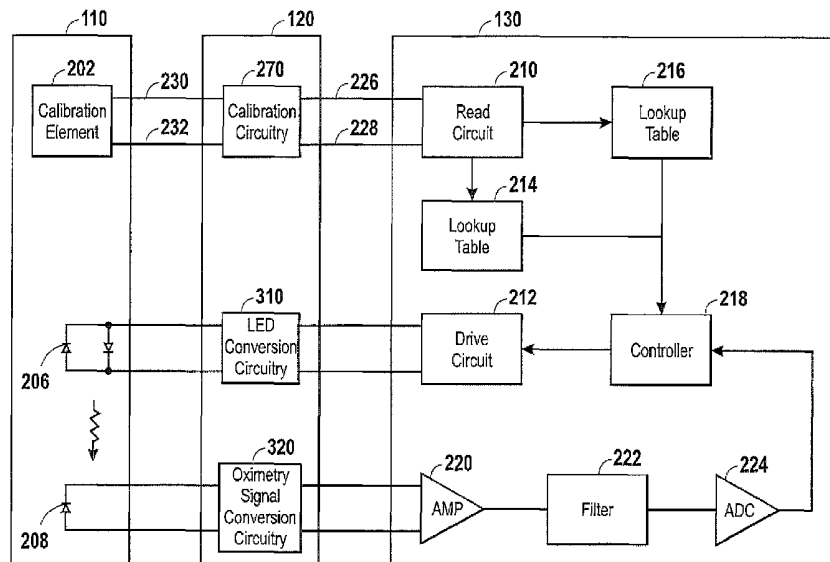

Related U.S. Application Data

continuation of application No. 12/415,244, filed on Mar. 31, 2009, now Pat. No. 8,364,224.
 (60) Provisional application No. 61/072,598, filed on Mar. 31, 2008.

(51) **Int. Cl.**
A61B 5/01 (2006.01)
A61B 5/024 (2006.01)
A61B 5/1495 (2006.01)

(56) **References Cited**

U.S. PATENT DOCUMENTS

5,995,855 A * 11/1999 Kiani A61B 5/14551
 600/310
 6,351,658 B1 * 2/2002 Middleman A61B 5/14551
 600/322
 6,356,774 B1 * 3/2002 Bernstein A61B 5/14552
 600/322
 6,490,466 B1 * 12/2002 Fein A61B 5/14551
 600/322
 6,600,940 B1 * 7/2003 Fein A61B 5/14552
 600/323
 6,708,049 B1 * 3/2004 Berson A61B 5/14551
 600/323
 6,850,788 B2 * 2/2005 Al-Ali A61B 5/02438
 128/903
 6,993,371 B2 1/2006 Kiani et al.
 7,047,054 B2 5/2006 Benni
 7,085,597 B2 8/2006 Fein et al.
 7,181,264 B2 2/2007 Wiesmann et al.
 7,313,427 B2 12/2007 Benni
 7,530,949 B2 5/2009 Al Ali et al.
 7,844,313 B2 11/2010 Kiani et al.
 7,844,315 B2 11/2010 Al-Ali
 8,095,195 B2 1/2012 Mannheimer et al.
 8,116,839 B1 * 2/2012 Norris A61B 5/14551
 600/310
 8,185,178 B2 5/2012 Swedlow et al.
 8,265,723 B1 * 9/2012 McHale A61B 5/14552
 600/310
 8,626,256 B2 1/2014 Fein et al.
 8,639,307 B2 1/2014 Fein et al.
 2002/0026107 A1 2/2002 Kiani et al.
 2002/0095077 A1 * 7/2002 Swedlow A61B 5/14551
 600/323
 2002/0140675 A1 * 10/2002 Ali A61B 5/0002
 345/158
 2003/0050545 A1 * 3/2003 Hicks A61B 5/14551
 600/322
 2004/0006261 A1 1/2004 Swedlow et al.
 2004/0267103 A1 * 12/2004 Li A61B 5/00
 600/323
 2005/0065417 A1 * 3/2005 Ali A61B 5/0002
 600/323
 2006/0030764 A1 2/2006 Porges et al.
 2006/0161054 A1 * 7/2006 Reuss A61B 5/00
 600/300

2006/0195024 A1 8/2006 Benni
 2006/0217604 A1 9/2006 Fein et al.
 2006/0217605 A1 9/2006 Fein et al.
 2006/0217606 A1 9/2006 Fein et al.
 2006/0217607 A1 9/2006 Fein et al.
 2006/0224059 A1 * 10/2006 Swedlow A61B 5/14551
 600/323
 2006/0229510 A1 10/2006 Fein et al.
 2006/0258926 A1 11/2006 Ali et al.
 2007/0032711 A1 * 2/2007 Coakley A61B 5/14552
 600/323
 2007/0043269 A1 2/2007 Mannheimer et al.
 2007/0043270 A1 2/2007 Mannheimer et al.
 2007/0043271 A1 2/2007 Mannheimer et al.
 2007/0043272 A1 2/2007 Mannheimer et al.
 2007/0043273 A1 2/2007 Mannheimer et al.
 2007/0043274 A1 2/2007 Mannheimer et al.
 2007/0043275 A1 2/2007 Mannheimer et al.
 2007/0043276 A1 2/2007 Mannheimer et al.
 2007/0043278 A1 2/2007 Mannheimer et al.
 2007/0043279 A1 2/2007 Mannheimer et al.
 2007/0043280 A1 2/2007 Mannheimer et al.
 2007/0043282 A1 2/2007 Mannheimer et al.
 2007/0049810 A1 3/2007 Mannheimer et al.
 2007/0088207 A1 4/2007 Mannheimer et al.
 2007/0208236 A1 * 9/2007 Hicks A61B 5/0059
 600/310
 2007/0255124 A1 * 11/2007 Pologe A61B 5/14551
 600/331
 2008/0015424 A1 * 1/2008 Bernreuter A61B 5/14551
 600/323
 2008/0039701 A1 * 2/2008 Ali A61B 5/0002
 600/301
 2008/0088467 A1 * 4/2008 Al-Ali A61B 5/14551
 340/679
 2008/0091092 A1 * 4/2008 Al-Ali A61B 5/0002
 600/310
 2008/0154098 A1 * 6/2008 Morris A61B 5/02416
 600/300
 2008/0221418 A1 * 9/2008 Al-Ali A61B 5/02416
 600/324
 2009/0182209 A1 * 7/2009 Benni A61B 5/14553
 600/323
 2009/0234207 A1 * 9/2009 Rantala G01D 21/00
 600/323
 2009/0281403 A1 * 11/2009 Benni A61B 5/14553
 600/331
 2010/0049018 A1 * 2/2010 Duffy A61B 5/1455
 600/323
 2010/0056886 A1 3/2010 Hurtubise et al.
 2010/0168605 A1 7/2010 Aarts
 2010/0312079 A1 * 12/2010 Larsen A61B 5/742
 600/323
 2013/0237772 A1 9/2013 Pisani et al.

FOREIGN PATENT DOCUMENTS

JP 4038280 1/2008
 JP 2008161657 7/2008

* cited by examiner

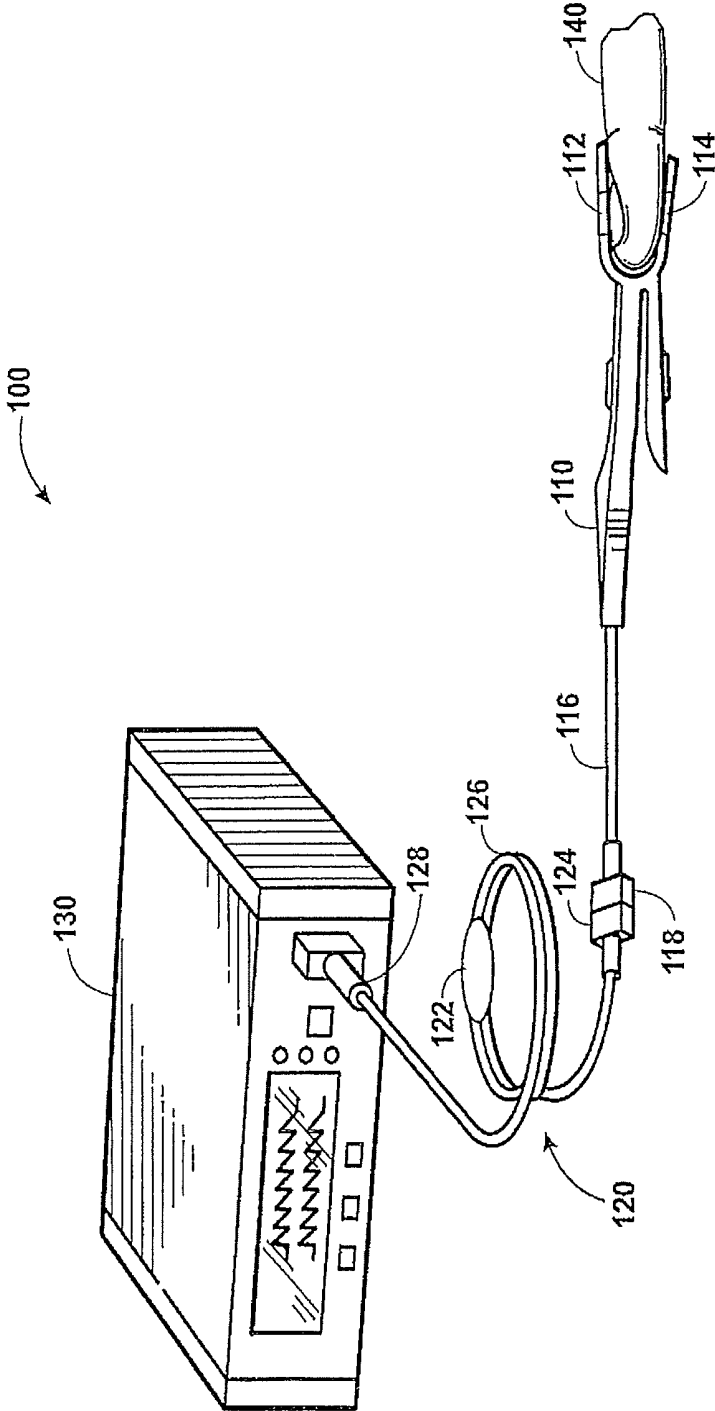

FIG. 1

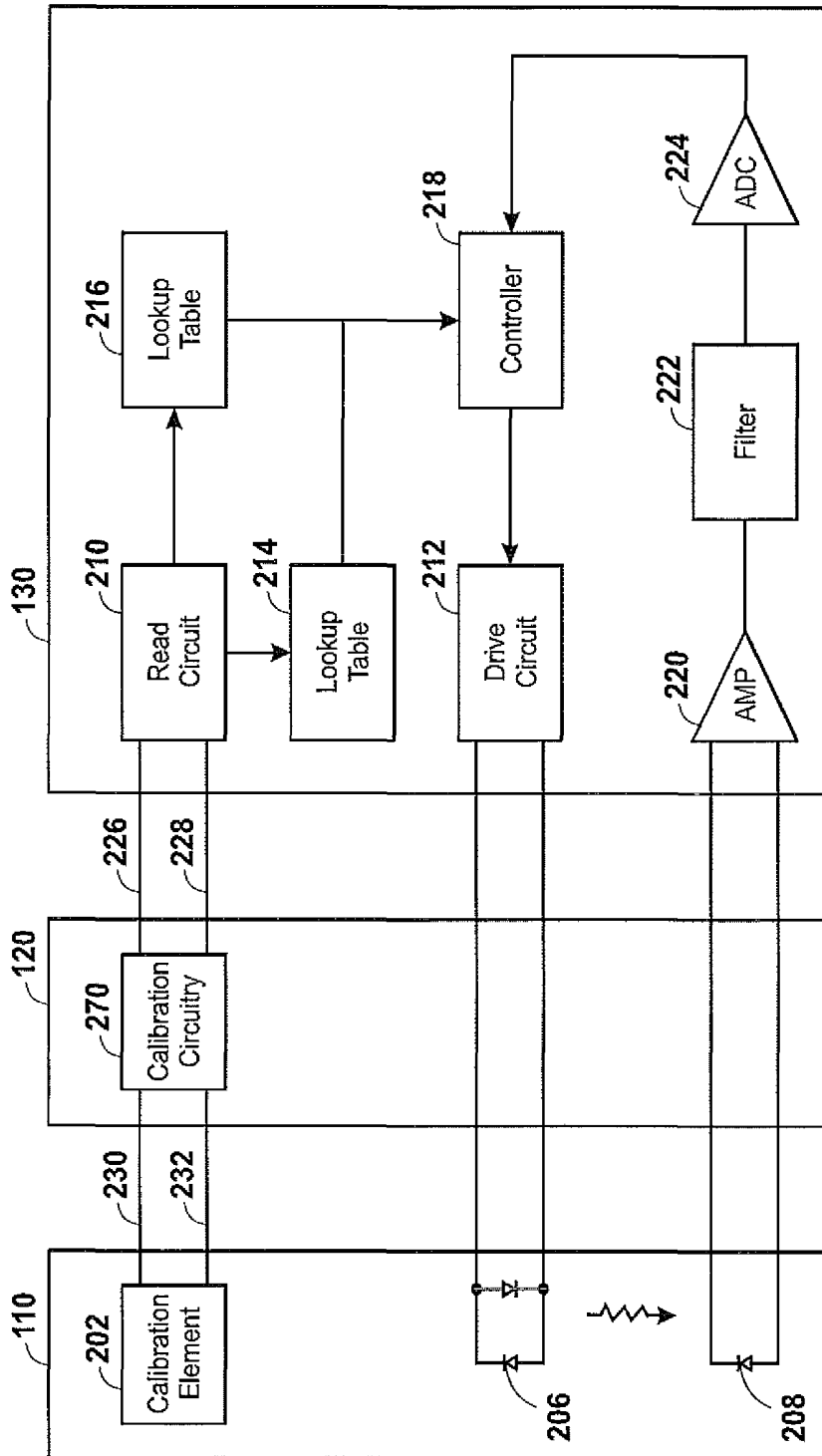

FIG. 2

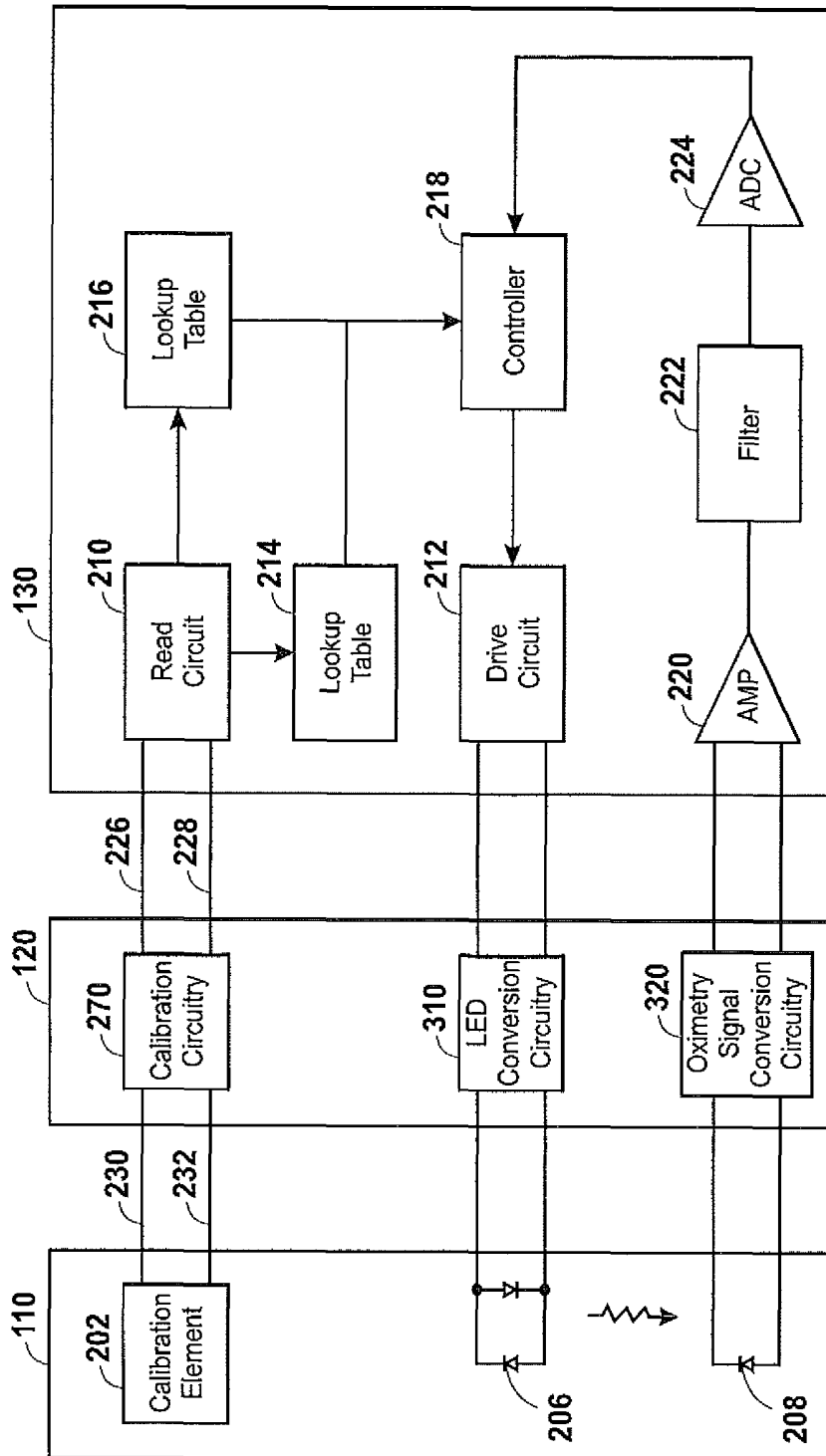

FIG. 3

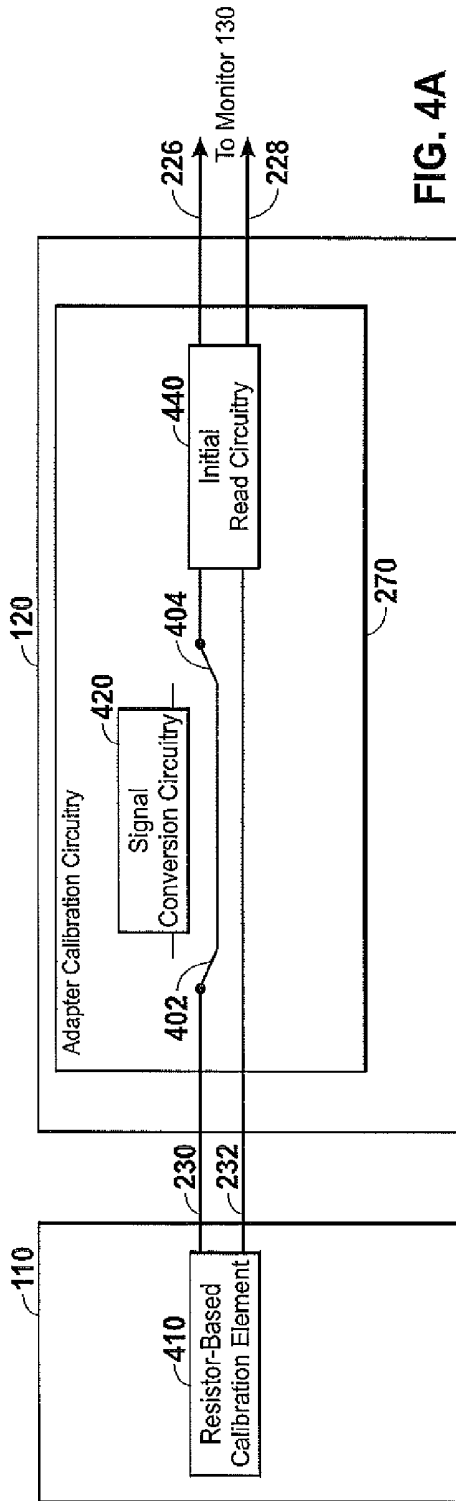

FIG. 4A

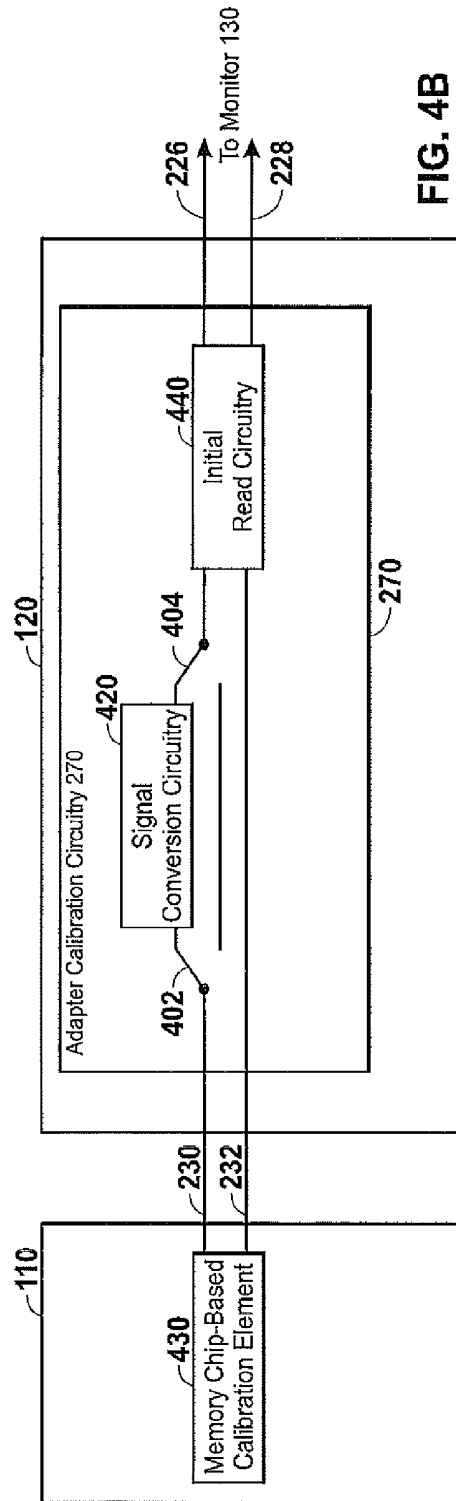

FIG. 4B

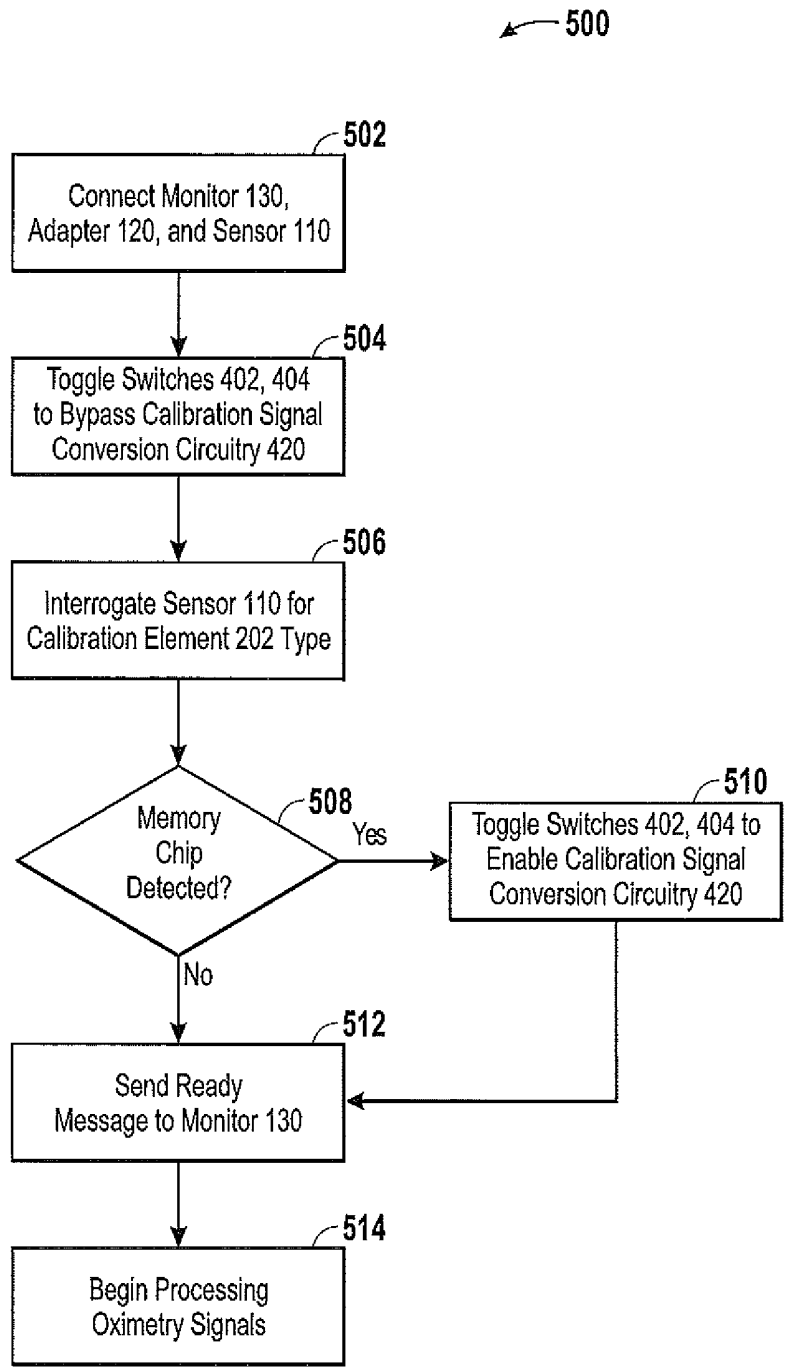

FIG. 5

SYSTEM AND METHOD FOR FACILITATING SENSOR AND MONITOR COMMUNICATION

CROSS-REFERENCE TO RELATED APPLICATIONS

This application is a continuation of U.S. application Ser. No. 13/747,137, filed Jan. 22, 2013, which is a continuation of U.S. application Ser. No. 12/415,244, filed Mar. 31, 2009, now U.S. Pat. No. 8,364,224 which issued on Jan. 29, 2013, which claims priority to U.S. Provisional Application No. 61/072,598, filed Mar. 31, 2008, which are incorporated by reference in their entirety herein for all purposes.

BACKGROUND

The present disclosure relates generally to pulse oximetry and, more specifically, to an adapter for connecting oximeter sensors with oximeter monitors.

This section is intended to introduce the reader to various aspects of art that may be related to various aspects of disclosed embodiments, which are described and/or claimed below. This discussion is believed to be helpful in providing the reader with background information to facilitate a better understanding of the various aspects of the present disclosure. Accordingly, it should be understood that these statements are to be read in this light, and not as admissions of prior art.

In the field of healthcare, caregivers (e.g., doctors and other healthcare professionals) often desire to monitor certain physiological characteristics of their patients. Accordingly, a wide variety of monitoring devices have been developed for monitoring many such physiological characteristics. These monitoring devices often provide doctors and other healthcare personnel with information that facilitates provision of the best possible healthcare for their patients. As a result, such monitoring devices have become a perennial feature of modern medicine.

One method for monitoring physiological characteristics of a patient is commonly referred to as pulse oximetry, and the devices built based upon pulse oximetry methods are commonly referred to as pulse oximeters. Pulse oximeters may be used to measure and monitor various blood flow characteristics of a patient. For example, a pulse oximeter may be utilized to monitor the blood oxygen saturation of hemoglobin in arterial blood (SpO_2), the volume of individual blood pulsations supplying the tissue, and/or the rate of blood pulsations corresponding to each heartbeat of a patient. In fact, the "pulse" in pulse oximetry refers to the time-varying amount of arterial blood in the tissue during each cardiac cycle.

In general, monitoring systems, such as pulse oximetry systems, include a sensor and a monitor. The sensor collects data that is transmitted to the monitor for analysis. For example, pulse oximeters typically utilize a non-invasive sensor that is placed on or against a patient's tissue that is well perfused with blood, such as a patient's finger, toe, forehead or earlobe. The pulse oximeter sensor emits light and photoelectrically senses the light after passage through the perfused tissue. The sensor then transmits data relating to the sensed light to the monitor. The light emitted by the sensor is typically selected to include one or more wavelengths that are absorbed or scattered in an amount related to the presence of oxygenated versus de-oxygenated hemoglobin in the blood. Thus, data collected by the sensor relating to detected light may be used by a pulse oximeter to

calculate one or more of the above-referenced physiological characteristics based upon the absorption or scattering of the light. For example, a monitor may use a determination of the amount of light absorbed and/or scattered, as detected by the sensor, to estimate an amount of oxygen in the tissue using various algorithms.

The sensors and monitors of typical monitoring systems, such as pulse oximeter systems, are often specifically configured to communicate with one another. For example, a sensor may be specifically configured to operate with a particular type of monitor. Indeed, if a sensor and a monitor are not specifically designed to cooperate, they may not function together. This can be an issue when upgrades are available for a sensor or monitor. For example, it may be desirable to utilize a new sensor that includes upgraded technology because it provides better performance and the upgraded technology is more affordable. However, older monitors, which can be expensive to replace, may not be able to take advantage of the improved sensor technology because they are not compatible with the updated technology.

SUMMARY

Certain aspects commensurate in scope with this disclosure are set forth below. It should be understood that these aspects are presented merely to provide the reader with a brief summary of certain embodiments of the disclosure and that these aspects are not intended to limit the scope of embodiments of the disclosure. Indeed, embodiments of the disclosure may encompass a variety of aspects that may not be set forth below.

According to an embodiment, there may be provided an adapter including communications circuitry configured to facilitate communication with an oximeter sensor, communications circuitry configured to facilitate communication with an oximeter monitor, and calibration circuitry configured to receive calibration information in a first form from the oximeter sensor and to convert the calibration information into a second form which is readable by the oximeter monitor.

According to an embodiment, there may also be provided a pulse oximetry system including an oximeter sensor, an oximeter monitor, and an adapter configured to receive calibration information in a first form from the oximeter sensor and to convert the calibration information into a second form which the oximeter monitor is capable of reading.

Finally, according to an embodiment, there may be provided a method for communicating calibration information from an oximeter sensor to an oximeter monitor including determining a type of calibration element present within the oximeter sensor, enabling calibration signal conversion circuitry within the adapter if the calibration element is a digital memory chip, and sending a message to the oximeter monitor to begin receiving oximetry data from the oximeter sensor.

BRIEF DESCRIPTION OF THE DRAWINGS

These and other features, aspects, and advantages of this disclosure may become better understood when the following detailed description of certain exemplary embodiments is read with reference to the accompanying drawings in which like characters represent like parts throughout the drawings, wherein:

FIG. 1 is a perspective view of a pulse oximetry system in accordance with an embodiment;

FIG. 2 is a block diagram of a pulse oximeter monitor, adapter, and sensor in accordance with an embodiment;

FIG. 3 is a block diagram of a pulse oximeter monitor, adapter, and sensor incorporating LED and oximetry signal conversion circuitry in accordance with an embodiment;

FIGS. 4A and 4B are block diagrams of a pulse oximeter sensor and adapter in accordance with an embodiment; and

FIG. 5 is a flowchart illustrating a method for initializing the signal conversion circuitry of an oximeter adapter in accordance with an embodiment.

While the present disclosure is susceptible to various modifications and alternative forms, specific exemplary embodiments thereof have been shown in the drawings and are herein described in detail. It should be understood, however, that the description herein of specific exemplary embodiments is not intended to limit the disclosure to the particular forms disclosed herein, but to the contrary, this disclosure is to cover all modifications and equivalents as defined by the appended claims.

DETAILED DESCRIPTION

Various embodiments will be described below. These described embodiments are only exemplary of the present disclosure. Additionally, in an effort to provide a concise description of these exemplary embodiments, all features of an actual implementation may not be described in the specification. It should be appreciated that in the development of any such actual implementation, as in any engineering or design project, numerous implementation-specific decisions must be made to achieve the developers' specific goals, such as compliance with system-related and business-related constraints, which may vary from one implementation to another. Moreover, it should be appreciated that such a development effort might be complex and time consuming, but would nevertheless be a routine undertaking of design, fabrication, and manufacture for those of ordinary skill having the benefit of this disclosure.

The present methods and systems generally relate to physiological monitoring instruments and, in particular, to systems and devices that cooperate with sensors that include a mechanism for storing and providing a monitor with data relating to measurement of a physiological characteristic. Embodiments of the present disclosure may include pulse oximetry sensors that include coded information relating to use of the sensors (e.g., a value associated with interpreting data from the sensor). Pulse oximetry systems are discussed below as examples to facilitate detailed discussion of present embodiments. However, the methods and systems discussed below are merely examples, and present embodiments are not limited to pulse oximetry devices. Indeed, some embodiments may be extended to various other physiological monitoring instruments.

In accordance with an embodiment, blood oxygen saturation, commonly denoted as SpO_2 , may be estimated as a ratio of oxygenated hemoglobin (HbO_2) to deoxygenated hemoglobin (Hb) present in a patient's tissue. Hemoglobin is the component of blood which transports oxygen throughout the body. The ratio of HbO_2 to Hb can be determined by shining light at certain wavelengths into a patient's tissue and measuring the absorbance of the light. In an embodiment, a first wavelength may be selected at a point in the electromagnetic spectrum where the absorption of HbO_2 differs from the absorption of reduced Hb , and a second wavelength may be selected at a different point in the

spectrum where the absorption of Hb and HbO_2 differs from those at the first wavelength. For example, wavelength selections for measuring normal blood oxygenation levels typically include a red light emitted at approximately 660 nm and a near-infrared light emitted at approximately 900 nm.

One method for estimating SpO_2 is to calculate a characteristic known as the ratio-of-ratios (Ratrat) of the absorption of red light (RED) to near-infrared light (IR). While various methods may be utilized to calculate Ratrat, in one method in accordance with an embodiment, a sensor is used to emit red and near-infrared light into a patient's tissue and detect the light that is reflected back. Signals indicative of the detected light are conditioned and processed to generate plethysmographic waveforms having generally sinusoidal shape, having both an alternating current (AC) and a direct current (DC) component. The AC and DC components of the RED wavelength and IR wavelength signals may then be used to calculate Ratrat, which has been observed to correlate well to SpO_2 . This observed correlation may be used to estimate SpO_2 based on the measured value of the Ratrat.

Therefore, pulse oximeters may precisely measure Ratrat in order to determine SpO_2 . The relationship between Ratrat and SpO_2 may follow a smooth line that serves as a sensor calibration curve. Because the light absorption of the blood's HbO_2 and Hb is significantly wavelength-dependent, the relationship between Ratrat and SpO_2 may depend heavily upon the specific wavelength emissions of the sensor's light emitting diodes (LEDs). For instance, if the red LED emits at 640 nm as opposed to 660 nm, the light absorption of the blood may increase compared to a truly red emitter. The result may be that the sensor's calibration curve would be shifted and rotated to a certain degree.

Therefore, more accurate measurements of SpO_2 may be taken when the sensor's calibration curve corresponds to the actual wavelengths of the sensor's LEDs. For this reason, pulse oximeter manufacturers may identify the emitted wavelengths in order to achieve accurate readings. Many manufacturers identify an LED wavelength range for a particular sensor and program a corresponding calibration curve into a pulse oximetry monitor that corresponds to this LED wavelength range. To do so, these manufacturers may use a resistor-encoding scheme in which several calibration curves are programmed into pulse oximeters to span a broad range of LED wavelengths.

This resistor calibration method, which may be abbreviated as RCAL™ in systems manufactured by the present assignee, communicates to the monitor which curves should be used. When the sensor is connected to the monitor, a resistor within the sensor may be read by the monitor to identify specifically which of the pre-programmed curves should be used to calculate SpO_2 values. During the manufacturing of each sensor, the wavelength characteristics of the red and infrared LEDs may be measured and an appropriate resistor may be installed in the sensor. The RCAL™ system may be used by the monitor to identify from a lookup table (e.g., Table 1) which of the pre-programmed curves should be used based on the specific resistor values.

TABLE 1

Example RCAL™ Lookup Values	
RCAL™ Resistor (Ω)	Calibration Curve
1000	Curve #1
2000	Curve #2

TABLE 1-continued

Example RCAL™ Lookup Values	
RCAL™ Resistor (Ω)	Calibration Curve
3000	Curve #3
...	...
N,000	Curve #N

However, predefining calibration curves to address LED wavelength variations can be an issue for several reasons. First, pulse oximetry manufacturers may not be able to take advantage of newer high-efficiency LEDs because their spectral properties may be different from those designed by semiconductor companies years ago. Newer LEDs can reduce power needs of oximeters, leading to longer battery life. In addition, newer LEDs can dramatically increase signal strength, improving monitoring performance. Therefore, as newer LEDs become available, oximeter manufacturers may want to be able to take advantage of the latest advancements in LED technology. Second, oximeter manufacturers may be constrained and unable to implement new sensor designs when the new designs do not precisely conform to the pre-programmed calibration curves in the monitors. Having to fit new sensors into the available choices of calibration curves may limit the possibilities for new sensor designs. Finally, many RCAL™ calibration curves were created in the mid-1980s, based on LEDs and sensor designs of that time. New sensors developed since then have had to conform to these pre-programmed curves to ensure compatibility across the installed base of oximeter monitors.

In response to these issues, new oximeter systems have been developed to provide for greater sensor and monitor performance while at the same time accommodating future sensor designs as patient care evolves. One such system accomplishes these objectives by incorporating a small digital memory chip within the sensor. Each digital memory chip may be programmed with the full calibration information for that sensor, along with any other sensor-specific data the oximeter can use to enhance performance. This design allows manufacturers to develop sensors that address specific clinical needs without being hampered by the earlier sensor calibration constraints.

This type of system still utilizes calibration. However, instead of having to fit within the pre-programmed curves within oximeter monitors, sensors with digital memory chips may hold their individual calibration curves in memory. As such, each sensor may be programmed with specific coefficients which define its calibration curve. Therefore, manufacturers can now store within the chip any calibration curve needed, whether for current sensor designs or for those created in the future. Because new calibration curves can be developed as needed, manufacturers can design new sensors with improved performance without the constraints of the past.

Though existing oximeter monitors could conceivably be re-programmed with additional curves, the process for doing so could prove very difficult, particularly when the large numbers of installed monitors around the world is taken into account. Building digital memory chips within sensors allows for integrating new sensor calibration curves without the hassle of updating oximeter monitors. Therefore, implementing upgrades through sensors, rather than monitors, may prove more cost effective and efficient.

In addition, the memory chip may provide room for additional sensor-specific operating parameters to be stored

within the sensor. For example, the model name of the sensor being stored, and model-specific troubleshooting tips may be provided. However, despite all of the advantages created by building a memory chip into the sensors, one major disadvantage may be created—the fact that oximeter monitors may not inherently be able to communicate with the sensors. Indeed, whereas older monitors may be expecting an encoded signal via a resistor, they may now be interfacing with a chip holding the calibration curve in memory. Conversely, when newer monitors are expecting to interface with a memory chip, they may experience only a resistor element in an older sensor. Therefore, it is now recognized that it would be advantageous to have an adapter which can modify the sensor signals accordingly.

FIG. 1 is a perspective view of a pulse oximetry system in accordance with an embodiment. The pulse oximetry system is generally indicated by reference numeral 100. The system 100 may include a sensor 110, an adapter 120, and a monitor 130 which cooperate to detect and analyze patient characteristics. In the illustrated embodiment, the monitor 130 couples via the adapter 120 to the sensor 110 that is applied to a patient 140. More specifically, the sensor 110 may be configured to detect and transmit signals to the monitor 130 via the adapter 120. The signals transmitted by the sensor 110 may be indicative of SpO₂ levels in the patient's 140 tissue. The adapter 120 may convert the signals from the sensor 110 into a form that is readable by the monitor 130. For example, the monitor may be configured to receive information from the sensor 110 relating to a resistance value (for calibration purposes) whereas the sensor 110 may be configured to transmit information to the monitor 130 relating to values read from a memory feature of the sensor 110.

In the illustrated embodiment, the sensor 110 includes a pair of LEDs 112, a photo detector 114, a sensor cable 116, and a sensor connecting plug 118. In FIG. 1, the sensor 110 is shown as a clip-on sensor. However, present embodiments can be applied to many sensor implementations, including those attached to a patient by adhesive and other attachment means. Light from the LEDs 112 at two different wavelengths (e.g., red and infrared) may be transmitted through a patient's blood perfused tissues (e.g., in a finger) and detected by the photo detector 114. Selection of the wavelengths of the LEDs 112 may be based on a number of factors. Such factors may include the absorption characteristics of the patient and transmission medium. The detected optical signal from the photo detector 114 may then be provided to the monitor 130 for processing.

The sensor 110 may be connected to the sensor cable 116. In the illustrated embodiment, the sensor cable 116 is directly connected to the adapter 120 via the sensor connecting plug 118. However, as will be appreciated by those in the art, the sensor 110 may also be connected directly to the monitor 130 (e.g., in instances where the sensor 110 is compatible with the monitor 130). In addition, in other embodiments, the sensor 110 may be configured to connect wirelessly with the adapter 120 and/or the monitor 130, obviating the need for the sensor cable 116 and sensor connecting plug 118.

Also, in the illustrated embodiment, the adapter 120 includes an adapter body 122, an adapter-to-sensor connecting plug 124, an adapter cable 126, and an adapter-to-monitor connecting plug 128. The adapter body 122 may contain all of the circuitry required to convert the signals from the sensor 110 into a form that is readable by the monitor 130. The adapter 120 may be directly connected to the sensor 110 via the adapter-to-sensor connecting plug 124

and adapter cable **126**. Similarly, the adapter may be connected to the monitor **130** via the adapter-to-monitor connecting plug **128** and adapter cable **126**. In addition, in other embodiments, the adapter **120** may be configured to connect wirelessly with the sensor **110** and/or the monitor **130**, obviating the need for the adapter cable **126** and adapter connecting plugs **124**, **128**. Also, the adapter **120** may have a self-contained power source (e.g., rechargeable battery) within the adapter body **122**, plug into a power outlet directly (using electrical cords not shown), or derive its power from the monitor **130**.

In the illustrated embodiment, the monitor **130** may be a pulse oximeter, such as those available from Nellcor Puritan Bennett LLC and/or Covidien, or may be another monitor for measuring other body-related metrics using spectrophotometric and/or other methods. Additionally, the monitor **130** may be a multi-purpose monitor suitable for performing pulse oximetry and measurement of other combinations of physiological and/or biochemical monitoring processes, using data acquired via the sensor **110**.

The adapter **120** has been described for use in combination with a sensor **110** and a monitor **130** wherein the monitor **130** performs the signal processing of the detected signal and compression of the processed data. In another embodiment, the adapter **120** may be configured to process (and compress, if necessary or desirable) the detected signal. This embodiment allows for independent operation of the sensor **110** and adapter **120** without support from a monitor **130**. The data stored within the sensor **110** and adapter **120** may be provided to a monitor **130** for display. The amount of signal processing and compression that can be achieved by circuitry within the adapter **120** may be primarily limited by the available technology, which inevitably improves over time. In the near term, physiological data that does not require extensive signal processing and compression (e.g., temperature, peak amplitude in a waveform, heart rate, and so on) can be collected and stored by the adapter **120**.

FIG. 2 is a block diagram of a pulse oximeter system incorporating a calibration element **202** within the sensor **110** in accordance with an embodiment. In one embodiment, the calibration element **202** may be a two-lead semiconductor digital memory chip. The calibration element **202** may be part of the sensor **110** which also includes red and infrared LEDs **206**, along with a photo detector **208**. If desired, the LEDs **206** may be replaced with other light emitting elements such as lasers.

The oximeter monitor **130** may include a read circuit **210**, a drive circuit **212**, lookup tables **214** and **216**, a controller **218**, an amplifier **220**, a filter **222**, and an analog-to-digital converter **224**. The read circuit **210** may be provided for reading multiple coded values across the two leads **226**, **228** connected to the adapter calibration circuitry **270** which may in turn be connected to the calibration element **202** via two other leads **230**, **232**. One value may be provided to a lookup table **214** to determine appropriate wavelength-dependent coefficients for the oxygen calculation. The other value(s) may then be provided to another lookup table(s) **216** which provides input (e.g., coefficients) to other calculations performed by the controller **218**. The controller **218** may provide signals to a drive circuit **212** to control the amount of drive current provided to the LEDs **206**.

The photo detector **208** may be connected through the amplifier **220** and the filter **222** to the A/D converter **224**. This forms a feedback path used by the controller **218** to adjust the drive current to optimize the intensity range of the signal received. For example, the signal may be within the analog range of the circuits employed. The signal may also

be within the range of the A/D converter **224**. For example, one rule that may be applied is to adjust LED drives and amplifier gains so that both red and IR signals fall between 40% and 80% of full scale reading of the A/D converter **224**.

If the sensor **110** is the type that uses the RCAL™ calibration method, leads **226** and **228** of the sensor **110** may be connected directly to leads **230** and **232** of the monitor **130**. As such, after connecting the sensor **110** to the monitor **130**, the read circuit **210** may read an analog voltage which corresponds to the RCAL™ resistor value of the sensor **110**. This voltage may then be applied to an A/D converter (not shown) to provide a value which can be used to index into the lookup table **214**. Conversely, certain issues may arise if the monitor **130** is configured to communicate with a sensor **110** which uses the RCAL™ calibration method but, instead, the sensor **110** uses a digital memory chip for calibration purposes.

However, in an embodiment, the adapter **120** contains adapter calibration circuitry **270** which is connected between the pairs of leads **226**, **228** and **230**, **232**. As such, the adapter calibration circuitry **270** may be responsible for converting signals sent to/from the read circuit **210** such that both older sensors (using resistors for calibration) and newer sensors (using digital memory chips for calibration) may be compatible with monitors configured to operate with sensors that use resistors for calibration. As will be appreciated by one skilled in the art, the methods described below for implementing an adapter **120** may also be applied to other situations. More specifically, similar methods may be used within the adapter calibration circuitry **270** such that both older sensors (using resistors for calibration) and newer sensors (using digital memory chips for calibration) may be compatible with monitors configured to connect to sensors which use digital memory chips for calibration. In either case, signals sent to/from the read circuit **210** may be converted from a first form to a second form with which the monitor **130** is configured to operate.

One objective of the adapter calibration circuitry **270** is to ensure that the monitor **130** responds in the same manner when either type of sensor—one that uses a resistor for calibration or one that uses a memory chip for calibration—is in communication with the monitor **130** via the adapter **120**. This can be accomplished using any number of methods and features, a few of which will be described below. However, it should be understood that these disclosed embodiments are not intended to be limited to the particular methods and features disclosed below.

FIG. 3 is a block diagram of a pulse oximeter system incorporating LED and oximetry signal conversion circuitry **310**, **320** in accordance with an embodiment. In addition to converting signals relating to sensor calibration, the adapter **120** may also be used for conversion of LED signals to the sensor **110** and oximetry signals from the sensor **110**. For instance, in response to information gathered from the memory chip in the sensor **110** (e.g., either calibration information or any other information stored in the memory chip), either the LED signals or returning oximetry signals may be modified and/or pre-conditioned to take into account particular characteristics of the sensor **110**. In addition, the adapter LED conversion circuitry **310** and/or the oximetry signal conversion circuitry **320** may simply be used to offload some of the functionality of the monitor **130**, depending on the circumstances.

FIGS. 4A and 4B are block diagrams of the adapter **120** and the sensor **110** in accordance with various embodiments. In these embodiments, the adapter calibration circuitry **270** may contain switches **402**, **404** enabling two alternate modes

of operation for the adapter 120. FIG. 4A illustrates the first mode of operation, where the adapter 120 is connected to the sensor 110 employing a resistor-based calibration element 410. In this situation, there is no need to use the calibration signal conversion circuitry 420. Therefore, it may be bypassed and the signal from the resistor-based calibration element 410 may simply be passed along through the adapter calibration circuitry 270 to the monitor 130. Conversely, FIG. 4B illustrates the second mode of operation, where the adapter 120 is connected to the sensor 110 employing a memory chip-based calibration element 430. In this situation, the calibration signal conversion circuitry 420 is needed and, therefore, should not be bypassed. In both situations, initial read circuitry 440 will most likely be used to ensure that switches 402, 404 are toggled appropriately upon connecting the sensor 110, the adapter 120, and the monitor 130 so that the read circuit 210 of the monitor 130 is able to process the signals returned by the sensor 110 via the adapter 120.

FIG. 5 shows an embodiment of a method for initializing the calibration signal conversion circuitry 420 of the adapter 120. Initially, the monitor 130, the adapter 120, and the sensor 110 may be connected to one another, as indicated by block 502. Upon detecting connection, the initial read circuitry 440 may toggle the switches 402, 404 (block 504) to bypass the calibration signal conversion circuitry 420. Clearing the connection between the adapter 120 and the sensor 110 allows for the initial read circuitry 440 to interrogate (block 506) the sensor 110 in order to establish what type of calibration element 202 is being used by the sensor 110.

At this point, a determination may be made (block 508) by the initial read circuitry 440 of whether a memory chip is used in sensor 110 for calibration purposes. This may be determined, for instance, by attempting to access a particular value from a memory chip. If the value is returned, the memory chip is being used. If the sensor 110 is, in fact, using a memory chip, the initial read circuitry 440 may toggle the switches 402, 404 to enable the calibration signal conversion circuitry 420, as indicated by block 510. If the sensor 110 is not using a memory chip, it may be assumed that a resistor is being used and the step of enabling the calibration signal conversion circuitry 420 may not be performed. Regardless, once the switches 402, 404 are in the correct location and the calibration signal conversion circuitry 420 has been appropriately enabled or bypassed, the initial read circuitry 440 may send a message to the read circuit 310 of the monitor 130 that it can proceed collecting oximetry information from the sensor 110 via the adapter 120, as indicated by blocks 512 and 514.

Therefore, once it has been determined that the sensor 110 is using a memory chip for calibration, the calibration signal conversion circuitry 420 may convert signals received from the memory chip within the sensor 110 so that the monitor 130 can operate in the same manner as if it were connected directly to a sensor using a resistor for calibration. Again, this can be accomplished using any number of methods, a few of which will be described below. However, it should be understood that the disclosed embodiments are not intended to be limited to the particular methods disclosed below.

In an embodiment, the calibration signal conversion circuitry 420 may contain an inverse lookup table, essentially mimicking all of the lookup values listed above in Table 1 and inverting them, as shown in Table 2. To use this method, the initial read circuitry 440 may obtain the calibration curve from the memory chip in the sensor 110 and use this curve as an index to lookup the corresponding RCAL™ resistor

value. Then, the initial read circuitry 440 may send an analog voltage to the read circuit 210 of the monitor 130 corresponding to the RCAL™ resistor value. To do this, the adapter 120 may be pre-programmed with an updated inverse lookup table corresponding to the lookup values used by the monitor 130. Alternatively, upon connection of the monitor 130 and the adapter 120, the calibration signal conversion circuitry 420 could interrogate the lookup table used by the monitor 130 and synchronize the values in the adapter's 120 inverse lookup table accordingly. In this manner, the inverse lookup table may function properly without pre-programming the inverse lookup table into the adapter 120 at the time the adapter 120 is manufactured.

TABLE 2

Example Inverse Lookup Values	
Calibration Curve	RCAL™ Resistor (Ω)
Curve #1	1000
Curve #2	2000
Curve #3	3000
...	...
Curve #N	N,000

In another embodiment, the calibration signal conversion circuitry 420 may contain an actual series of resistors that can be switched on and off to create a combined resistance through the calibration signal conversion circuitry 420 approximating the RCAL™ resistance that would have been used if the sensor 110 used a resistor for calibration purposes. This method may obviate the need for converting the signal sent to the read circuit 210 since there would be an actual resistance value in place. In other words, using this method, the calibration signal conversion circuitry 420 may physically recreate the resistance that would have been used if the sensor used a resistor for calibration purposes.

While the subject of this disclosure may be susceptible to various modifications and alternative forms, specific embodiments have been shown by way of example in the drawings and have been described in detail herein. However, it should be understood that this disclosure is not intended to be limited to the particular forms disclosed. Rather, this disclosure is to cover all modifications, equivalents, and alternatives falling within the spirit and scope of this disclosure as defined by the following appended claims.

What is claimed is:

1. An adapter, comprising:

communications circuitry configured to facilitate communication with an oximeter sensor and an oximeter monitor; and

circuitry configured to identify the presence of a digital memory chip in the oximeter sensor by attempting to access a particular value expected from the digital memory chip and determining whether the expected value is returned, to use calibration information received from the oximeter sensor to modify signals received from a photo detector within the oximeter sensor if the expected value is returned, and to utilize a lookup table stored within a memory of the adapter to determine appropriate calibration information for the oximeter sensor and to use the determined appropriate calibration information to modify signals received from the photo detector within the oximeter sensor if the expected value is not returned, and to provide, via the communications circuitry, the modified signals to the oximeter monitor to enable the oximeter monitor to

11

display information related to a physiological parameter value of a patient coupled to the oximeter sensor.

2. The adapter of claim 1, wherein the adapter is configured to wirelessly communicate, via the communication circuitry, with the oximeter sensor, the oximeter monitor, or both.

3. The adapter of claim 1, wherein the adapter comprises an independent power source.

4. The adapter of claim 1, wherein the adapter comprises an adapter body disposed on an adapter cable having an adapter-to-oximeter monitor connecting plug and an adapter-to-oximeter sensor connecting plug.

5. A pulse oximetry system, comprising:
an oximeter sensor comprising at least one photo detector;
and

an adapter configured to:

couple the oximeter sensor to an oximeter monitor;
receive a resistance value indicative of a wavelength of light emitted by an emitter of the oximeter sensor from the oximeter sensor;

access a lookup table that relates resistance values to calibration curves, wherein the lookup table is stored within a memory of the adapter;

compare the received resistance value to the resistance values in the lookup table to convert the received resistance value to an appropriate calibration curve;
receive signals detected by at least one photo detector within the oximeter sensor;

modify signals received from the photo detector using the appropriate calibration curve; and

provide the modified signals to the oximeter monitor to enable the oximeter monitor to display information related to a physiological parameter value of a patient coupled to the oximeter sensor.

6. The system of claim 5, wherein the adapter comprises an independent power source.

7. The system of claim 5, wherein the adapter is configured to wirelessly communicate with the oximeter sensor, the oximeter monitor, or both.

8. The system of claim 5, wherein the adapter comprises an adapter body disposed on an adapter cable having an adapter-to-oximeter monitor connecting plug and an adapter-to-oximeter sensor connecting plug.

9. A method of processing data obtained by an oximeter sensor, the method comprising:

utilizing circuitry of an adapter configured to wirelessly couple the oximeter sensor to an oximeter monitor to:
wirelessly receive from the oximeter sensor information related to a wavelength of light emitted by an emitter of the oximeter sensor;

wirelessly receive from the oximeter sensor signals detected by at least one photo detector within the oximeter sensor;

modify the received signals based on the received information; and

wirelessly provide the modified signals to the oximeter monitor to enable the oximeter monitor to display information related to a physiological parameter value of a patient coupled to the oximeter sensor.

12

10. The method of claim 9, comprising utilizing the circuitry of the adapter to identify the presence of a digital memory chip in the oximeter sensor, and if the digital memory chip is identified, receiving the information related to the wavelength of light emitted by the emitter of the oximeter sensor from the digital memory chip and using the information to modify the received signals.

11. The method of claim 10, wherein to identify the presence of the digital memory chip the circuitry attempts to access a particular value expected from the digital memory chip and determines whether the expected value is returned.

12. The adapter of claim 1, wherein the circuitry is configured to use the calibration information or the determined appropriate calibration information to process the signals to determine the physiological parameter value, and the modified signals provided to the oximeter monitor comprise the determined physiological parameter value.

13. The adapter of claim 12, wherein the adapter is configured to store the determined physiological parameter value on the memory.

14. The adapter of claim 12, wherein the determined physiological parameter value comprises temperature, heart rate, or oxygen saturation.

15. The adapter of claim 1, wherein the lookup table relates resistance values to calibration curves.

16. The adapter of claim 1, wherein the appropriate calibration information is a calibration curve.

17. The adapter of claim 1, wherein the adapter is configured to connect to the oximeter sensor via an adapter cable and an adapter-to-sensor connecting plug and the adapter is configured to connect to the oximeter monitor via the adapter cable and an adapter-to-monitor connecting plug.

18. The system of claim 5, wherein the adapter is configured to use the appropriate calibration curve to process the signals to determine the physiological parameter value, and the modified signals provided to the oximeter monitor comprise the determined physiological parameter value.

19. The system of claim 5, wherein the adapter is configured to connect to the oximeter sensor via an adapter cable and an adapter-to-sensor connecting plug and the adapter is configured to connect to the oximeter monitor via the adapter cable and an adapter-to-monitor connecting plug.

20. The method of claim 9, wherein utilizing circuitry of the adapter to modify the received signals comprises utilizing the circuitry of the adapter to process the received signals to determine the physiological parameter value, and utilizing circuitry of the adapter to wirelessly provide the modified signals to the oximeter monitor comprises utilizing the circuitry of the adapter to wirelessly provide the physiological parameter value of the patient.

21. The method of claim 9, comprising utilizing the circuitry of the adapter to wirelessly interrogate the oximeter monitor to obtain information related to the oximeter monitor and modify the received signals based on the information related to the oximeter monitor.

22. The method of claim 9, wherein the received information comprises a calibration curve.

* * * * *

专利名称(译)	用于促进传感器和监视器通信的系统和方法		
公开(公告)号	US9693718	公开(公告)日	2017-07-04
申请号	US14/613142	申请日	2015-02-03
[标]申请(专利权)人(译)	柯惠有限合伙公司		
申请(专利权)人(译)	COVIDIEN LP		
当前申请(专利权)人(译)	COVIDIEN LP		
[标]发明人	BOYCE ROBIN NORDSTROM BRAD RAVID ARIE WANG HUI		
发明人	BOYCE, ROBIN NORDSTROM, BRAD RAVID, ARIE WANG, HUI		
IPC分类号	A61B5/1455 A61B5/00 A61B5/1495 A61B5/024 A61B5/01		
CPC分类号	A61B5/14551 A61B5/0002 A61B5/01 A61B5/02416 A61B5/1495 A61B5/14552 A61B5/6826 A61B5/6838 A61B5/742 A61B5/7232 A61B2562/085		
优先权	12/415244 2013-01-29 US 61/072598 2008-03-31 US		
其他公开文献	US20150150495A1		
外部链接	Espacenet USPTO		

摘要(译)

本文公开的实施例可以包括适配器，该适配器能够转换来自血氧计传感器的信号，使得信号可由血氧计监视器读取。在一个实施例中，适配器能够转换与来自血氧计传感器的校准信息有关的信号。校准信息可以涉及血氧计传感器内的发光二极管的波长。在特定实施例中，适配器将以与存储在数字存储器芯片中的数据值相关的第一形式的波长校准信息转换为与血氧计传感器内的预期电阻器的电阻值相关的第二形式。

