



US 20200138380A1

(19) **United States**

(12) **Patent Application Publication**
GU et al.

(10) **Pub. No.: US 2020/0138380 A1**

(43) **Pub. Date: May 7, 2020**

(54) **HEART RATE DETECTION DEVICE AND
OPERATING METHOD THEREOF,
PHYSIOLOGICAL DETECTION DEVICE**

(52) **U.S. Cl.**

CPC *A61B 5/7207* (2013.01); *A61B 5/0006*
(2013.01); *A61B 5/0408* (2013.01); *A61B*
5/0064 (2013.01); *A61B 5/02405* (2013.01);
A61B 5/02416 (2013.01)

(71) Applicant: **PixArt Imaging Inc.**, Hsin-Chu County
(TW)

(72) Inventors: **Ren-Hau GU**, Hsin-Chu County (TW);
Chih-Hsin LIN, Hsin-Chu County
(TW)

(57)

ABSTRACT

(21) Appl. No.: **16/177,433**

(22) Filed: **Nov. 1, 2018**

Publication Classification

(51) **Int. Cl.**

A61B 5/00 (2006.01)
A61B 5/024 (2006.01)

There is provided a heart rate detection device including a sensing unit for sensing emergent light from subcutaneous tissues illuminated by a single light source of multiple light colors to output multiple light detection signals associated with multiple wavelengths. The heart rate detection device further includes a processor uses the multiple light detection signals associated with the multiple wavelengths to cancel motion artifact to obtain a clean heart rate signal.

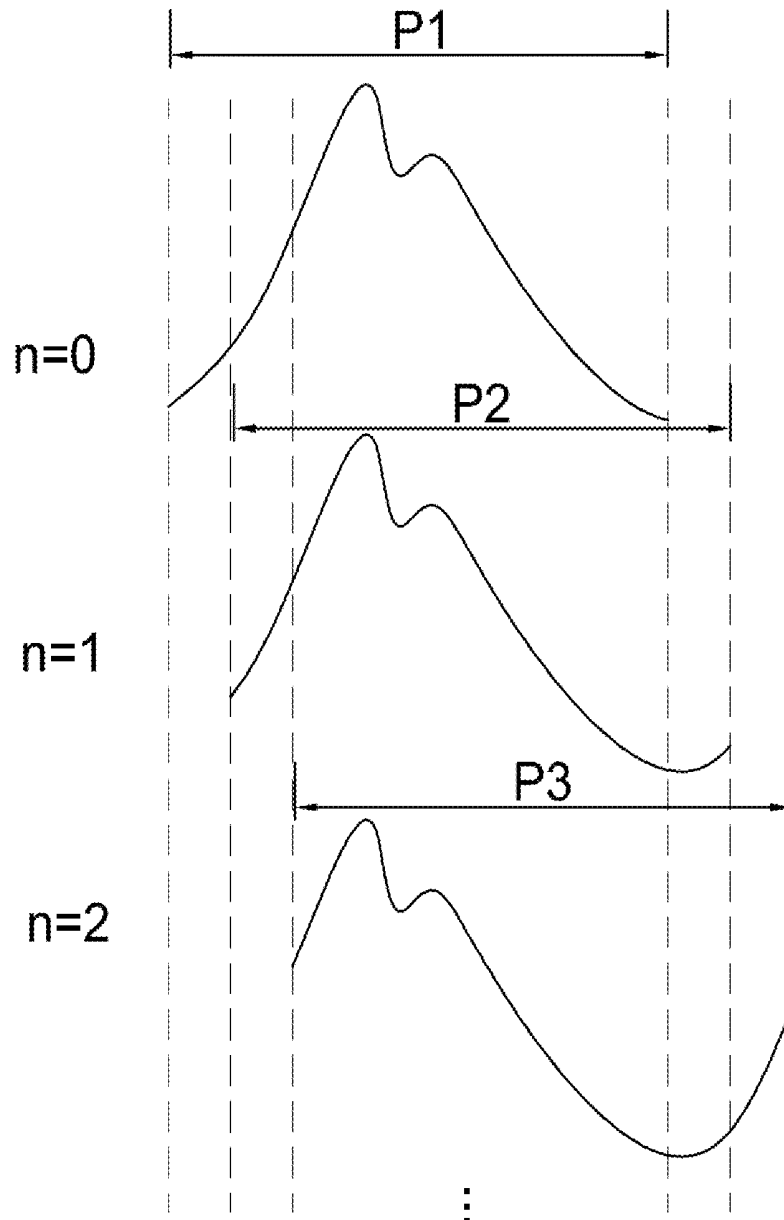

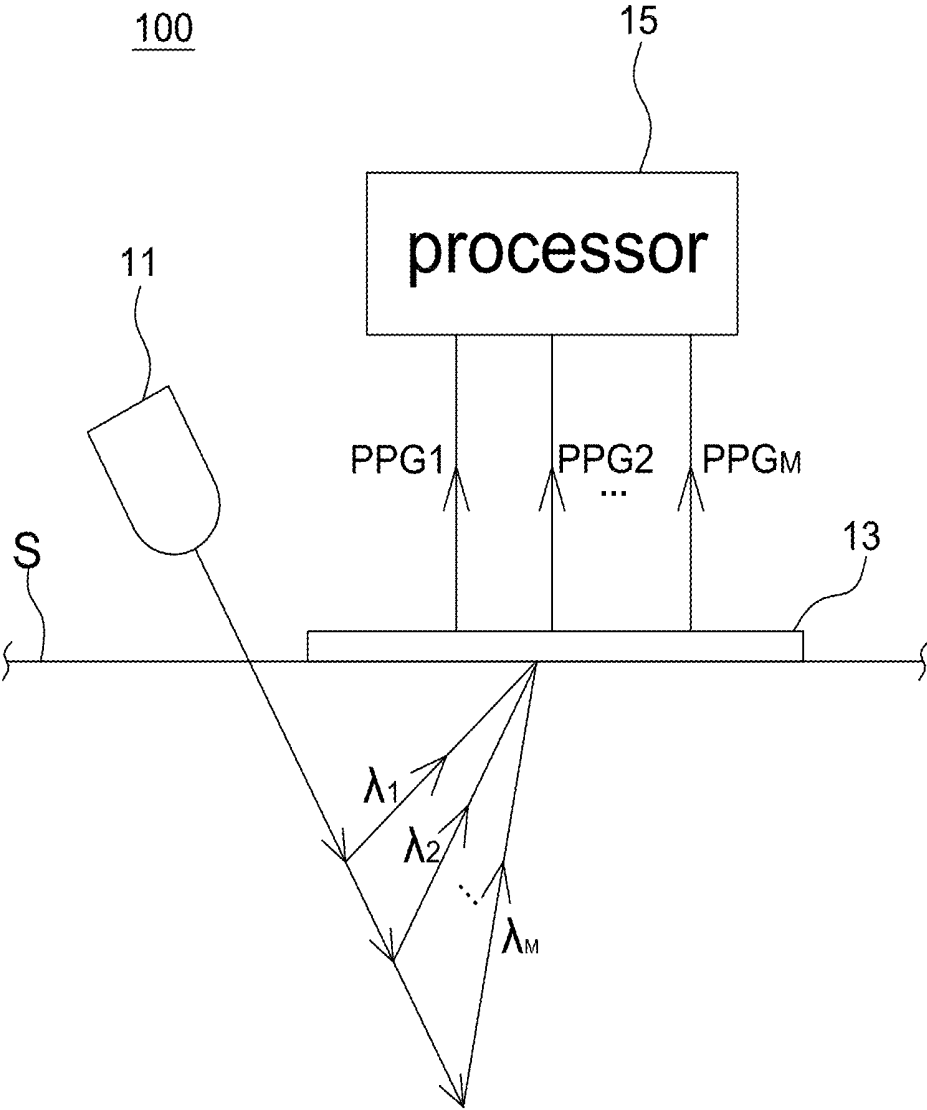

FIG. 1

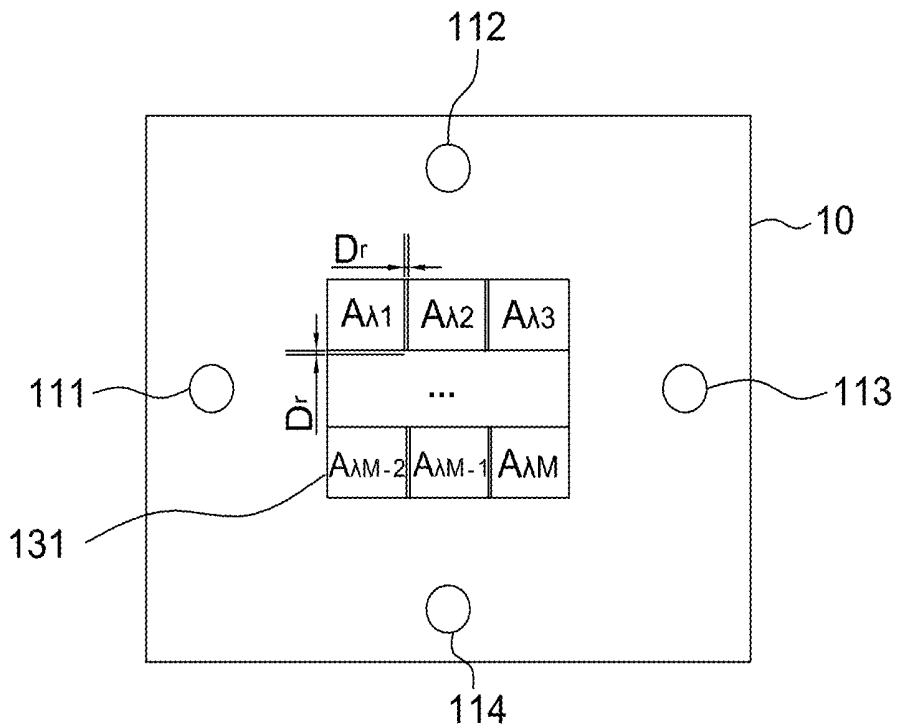

FIG. 2A

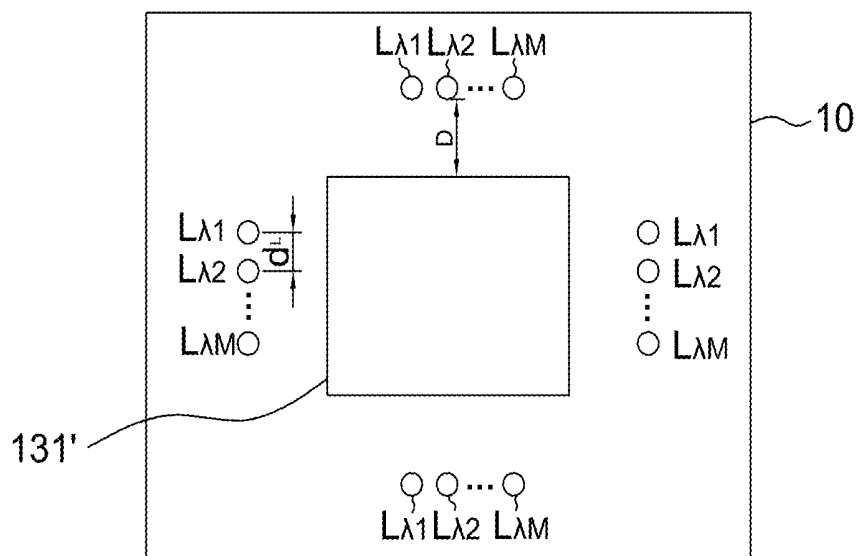

FIG. 2B

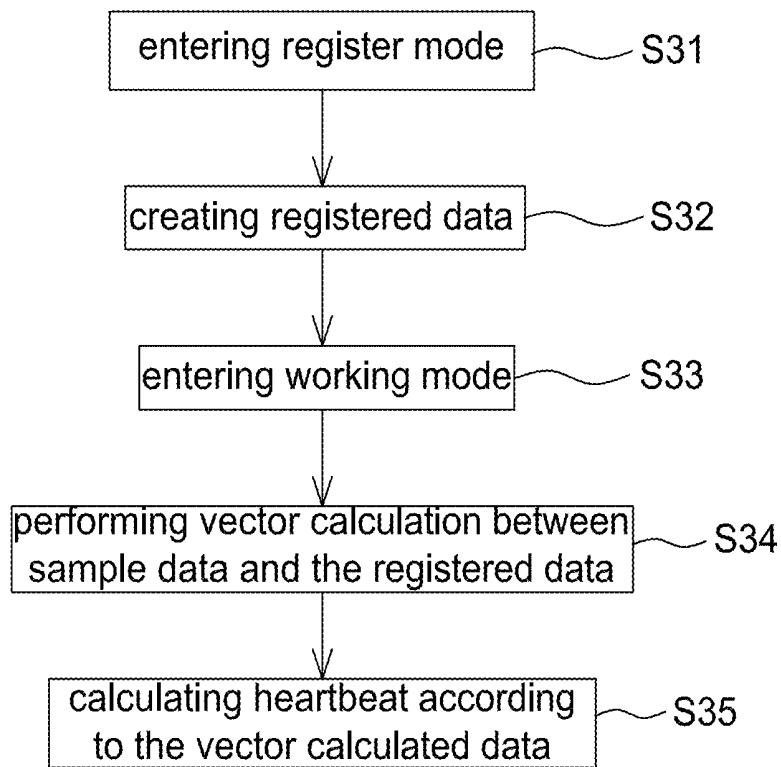

FIG. 3A

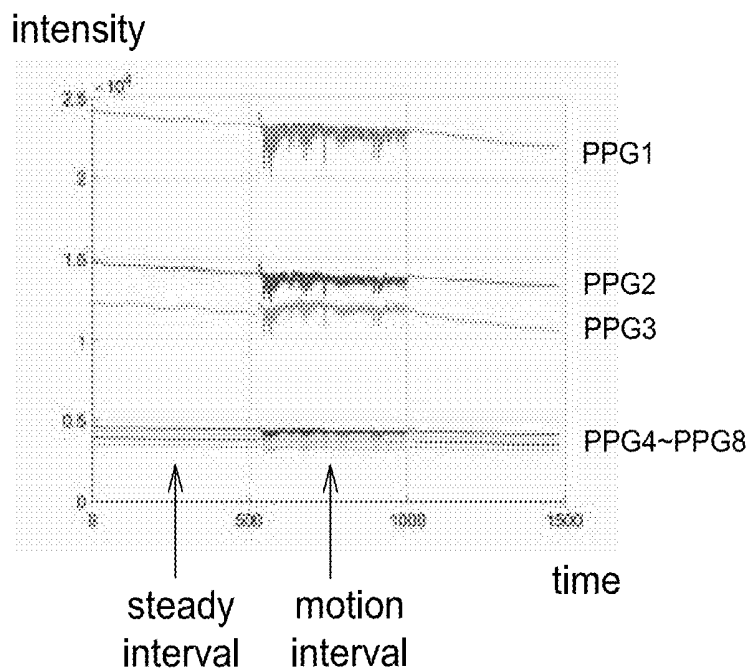

FIG. 3B

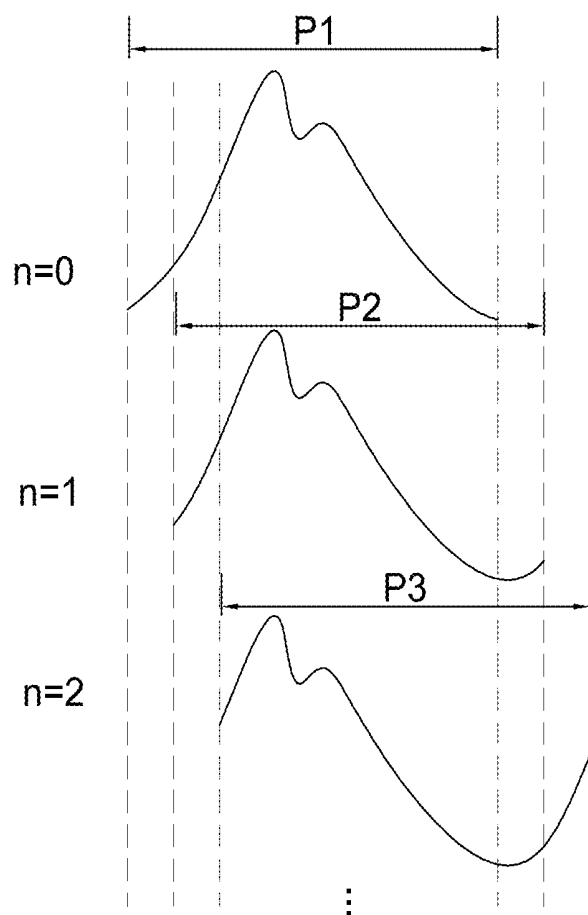

FIG. 4

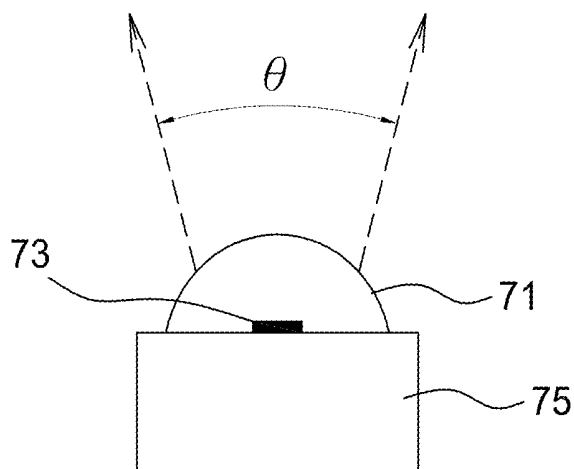

FIG. 5

HEART RATE DETECTION DEVICE AND OPERATING METHOD THEREOF, PHYSIOLOGICAL DETECTION DEVICE

BACKGROUND

1. Field of the Disclosure

[0001] This disclosure generally relates to the physiological detection and, more particularly, to a heart rate detection device capable of removing motion artifact caused by muscle activities by using light of multiple wavelengths and an operating method thereof.

2. Description of the Related Art

[0002] Conventionally, the heart rate detection can be performed by analyzing electrocardiogram (ECG). However, two electrodes are required to detect the ECG such that it is not convenient in operation. Therefore, in recent years an optical type of heart rate detection is used, and an optical heart rate detector is adaptable to portable and wearable electronic devices.

[0003] It is known that the optical physiological detection can be influenced by the relative movement between a detection device and a skin surface. Especially when an optical detection device is applied to a wearable device, a user likes to use the optical detection device to detect the heart rate variation during exercises such that the detection accuracy is degraded due to the influence of noises.

[0004] One conventional method to reduce the noises is to operate an optical physiological detection device in conjunction with an acceleration detector. The detection result of the acceleration detector is used to denoise the detection result of the optical physiological detection device so as to increase the detection accuracy. However, this kind of denoising method cannot remove noises caused by simple muscle activities, e.g., a user only moving his/her wrist or finger(s) without waving his/her arm. In this scenario, the acceleration detector is not able to generate usable results for denoising.

[0005] In addition, in the conventional physiological detection, the influence of noises on detection results caused by said simple muscle activities is not discussed, and the method of how to remove this motion artifact is not provided.

[0006] Accordingly, it is necessary to provide a physiological detection device capable of removing the motion artifact caused by muscle activities under a detected skin region so as to improve the detection accuracy.

SUMMARY

[0007] The present disclosure provides a heart rate detection device and an operating method thereof that perform a vector operation between a predetermined intensity distribution of multiple light colors and current light detection signals of the multiple light colors so as to eliminate the motion artifact in detected photoplethysmogram (PPG) signals.

[0008] The present disclosure further provides a physiological detection device with high detection efficiency and low power consumption.

[0009] The present disclosure provides a heart rate detection device including at least one light source, a light detector and a processor. Each of the at least one light source

is configured to emit light covering multiple wavelengths to illuminate a skin surface of a user. The light detector has a sensing unit configured to sense emergent light from the skin surface and output multiple light detection signals associated with different light colors corresponding to the multiple wavelengths. The processor is configured to perform a vector calculation between the multiple light detection signals and a pre-stored intensity distribution of the different light colors to remove a motion artifact.

[0010] The present disclosure further provides an operating method of a heart rate detection device. The heart rate detection device includes a light source of multiple wavelengths, a light detector and a processor. The operating method includes the steps of: entering a register mode, the register mode including: illuminating, by the light source, a first skin surface of a user; sensing, by the light detector, emergent light from the first skin surface to generate multiple first light detection signals associated with different light colors; and calculating and storing, by the processor, registered data of a plurality of sections of sample data associated with the different light colors; and entering a working mode, the working mode including: illuminating, by the light source, a second skin surface of a user; sensing, by the light detector, emergent light from the second skin surface to generate multiple second light detection signals associated with the different light colors; and performing, by the processor, a vector calculation between every section of sample data of the multiple second light detection signals and the registered data to remove a motion artifact.

[0011] The present disclosure further provides a physiological detection device including a white light source, a molding and a pixel array. The white light source is configured to emit white light having a color temperature between 2800K and 3200K. The molding is formed upon the white light source and configured to constrain an emission angle of the white light between 60 and 80 degrees. The pixel array is covered by a filter layer having a passband between 570 nm and 610 nm configured to filter the white light.

[0012] In the embodiments of the present disclosure, the light detector is used to sense reflected and scattered light from subcutaneous tissues illuminated by a light source of multiple wavelengths. The light source of multiple wavelengths is a white light emitting diode (LED) or white light laser diode (LD). Or, the light source of multiple wavelengths is formed by multiple LED dies or multiple LD dies respectively emitting light of different wavelengths. A distance between different dies is preferably smaller than 2000 micrometers such that emission lights therefrom go through substantially identical muscle fibers or bundles. For example, said different dies are formed on the same substrate.

[0013] In the embodiments of the present disclosure, it is preferably to use a single pixel matrix to operate in conjunction with a light source of multiple wavelengths. The pixel distance between pixels of said single pixel matrix is preferably smaller than 2000 micrometers to receive emergent lights from substantially identical muscle fibers or muscle bundles.

[0014] In the embodiments of the present disclosure, when the light source of multiple wavelengths is a white light source, a pixel array of the light detector is covered by a filter layer of multiple colors to achieve the purpose of detecting light of different colors. If the light source of multiple wavelengths is formed by multiple dies for emitting

light of different colors, the pixel array of the light detector is not covered by a filter layer of different light colors. By lighting the dies to emit light of different colors at different times, the purpose of detecting light of different colors is also achievable.

[0015] In the embodiments of the present disclosure, at least two light wavelengths are used, and a wavelength difference between different light wavelengths is preferably larger than 25 nm to achieve a better denoising effect. However, if only two light wavelengths are used, the wavelength difference should be selected as large as possible, e.g., preferably larger than 50 nm.

BRIEF DESCRIPTION OF THE DRAWINGS

[0016] Other objects, advantages, and novel features of the present disclosure will become more apparent from the following detailed description when taken in conjunction with the accompanying drawings.

[0017] FIG. 1 is a schematic block diagram of a heart rate detection device according to one embodiment of the present disclosure.

[0018] FIG. 2A is a schematic diagram of the arrangement of the light source and light detector of a heart rate detection device according to one embodiment of the present disclosure.

[0019] FIG. 2B is a schematic diagram of the arrangement of the light source and light detector of a heart rate detection device according to another embodiment of the present disclosure.

[0020] FIG. 3A is a flow chart of an operating method of a heart rate detection device according to one embodiment of the present disclosure.

[0021] FIG. 3B is a schematic diagram of multiple light detection signals detected by a heart rate detection device according to one embodiment of the present disclosure.

[0022] FIG. 4 is a schematic diagram of vector calculated data generated by a heart rate detection device according to one embodiment of the present disclosure.

[0023] FIG. 5 is a schematic diagram of a white light source and a molding thereon of a physiological detection device according to one embodiment of the present disclosure.

DETAILED DESCRIPTION OF THE EMBODIMENT

[0024] It should be noted that, wherever possible, the same reference numbers will be used throughout the drawings to refer to the same or like parts.

[0025] The physiological detection device of the present disclosure is used to detect photoplethysmogram (PPG) signals, and calculate a heart rate and analyze the user state reflected by a heart rate waveform according to the PPG signals. In addition to eliminate noises caused by a relative movement between the device and a detected skin, the physiological detection device of the present disclosure further removes a motion artifact from muscle fibers or muscle bundles under the detected skin (even no relative movement between the device and the detected skin), e.g., caused by activities like typing, rotating wrist, folding fingers and stretching fingers.

[0026] Referring to FIG. 1, it is a schematic block diagram of a heart rate detection device **100** according to one embodiment of the present disclosure. The heart rate detec-

tion device **100** includes at least one light source of multiple wavelengths **11**, a light detector **13** and a processor **15**, wherein the light detector **13** and the processor **15** are formed, for example, in the same sensor chip, but not limited to. In one non-limiting embodiment, the light source **11**, the light detector **13** and the processor **15** are formed in one encapsulation, and embedded in a wearable or portable electronic device such as a watch or a cell phone.

[0027] The light source **11** includes, for example, a light emitting diode (LED), a laser diode (LD) or the like. The light detector **13** includes, for example, a CCD image sensor, a CMOS image sensor or the like. The processor **15** includes, for example, a digital signal processor (DSP), a microcontroller (MCU), a graphic processing unit (GPU), a central processing unit (CPU), an application specific integrated circuit (ASIC) or the like.

[0028] Each of the at least one light source **11** emits light covering or containing multiple wavelengths (e.g., $\lambda_1, \lambda_2 \dots \lambda_M$ shown in FIG. 1) to illuminate a skin surface S of a user, wherein the skin surface S is determined according to an arranged location of the heart rate detection device **100**, e.g., on a forearm or upper arm, without particular limitations. A wavelength range of the multiple wavelengths is determined according to a number of required wavelengths. For example, if a number of detection signals associated with different light colors required in calculating a heart rate (illustrated by an example below) is larger, a wider wavelength range is used. As shown in FIG. 1, although lights of different colors have different penetration depths, they still go through at least some identical tissues. For example, a wavelength difference between the different light colors is at least 25 nm to allow the detection signals to have enough difference therebetween.

[0029] The light detector **13** includes a sensing unit (e.g., a single pixel array **131** in FIG. 2A) used to output multiple light detection signals associated with different light colors corresponding to the multiple wavelengths, wherein the light detection signals are referred as PPG signals herein, e.g., FIG. 1 showing light detection signals $PPG_1, PPG_2 \dots PPG_M$. As body tissues have different absorptivity on different light colors, different light detection signals have different intensities, e.g., referring to FIG. 3B.

[0030] Referring to FIGS. 2A and 2B, they are schematic diagrams of arranging the light source and the light detector in a heart rate detection device according to some embodiments of the present disclosure.

[0031] In one non-limiting embodiment, the light source **11** is a white light source. The single pixel array **131** includes multiple pixel regions, e.g., FIG. 2A showing pixel regions A_{λ_1} to A_{λ_M} . The multiple pixel regions A_{λ_1} to A_{λ_M} are covered by a filter layer of different light colors (e.g., corresponding to λ_1 to λ_M) to allow the multiple pixel regions A_{λ_1} to A_{λ_M} of the single pixel array **131** to output multiple detection signals (e.g., $PPG_1, PPG_2 \dots PPG_M$ shown in FIG. 1) associated with the different light colors. For example, the pixel region A_{λ_1} outputs PPG_1 , the pixel region A_{λ_2} outputs PPG_2 , and so on.

[0032] Each pixel region A_{λ_1} to A_{λ_M} includes one or multiple pixels. In one non-limiting aspect, each pixel region has a substantially identical area and further has a same number of pixels, but not limited thereto. When one pixel region includes multiple pixels, light detection signals of said multiple pixels are added by a hardware circuit or

software codes to output a sum of light detection signals as the light detection signals $PPG_1, PPG_2 \dots PPG_M$ shown in FIG. 1.

[0033] It should be mentioned that although FIG. 2A shows four white light sources **111-114** each emitting white light on a substrate **10**, it is used to increase the possibility of detecting a motion artifact of muscles by the light detector **13**. The heart rate detection device **100** of the present disclosure is for removing noises of tiny activities of muscles under the detected skin, and muscle bundles that have activities are determined according to the type of user's motion, such as finger movement. In some scenarios, emission light from light sources of multiple wavelengths **111** and **113** arranged at two opposite sides along a first direction of the pixel array **131** of the light detector **13** cause the pixel array **131** to detect a motion artifact but emission light from light sources of multiple wavelengths **112** and **114** arranged at two opposite sides along a second direction of the pixel array **131** of the light detector **13** do not cause the pixel array **131** to detect the motion artifact, or vice versa. Or emission light from all white light sources **111** to **114** can cause the pixel array **131** to detect the motion artifact.

[0034] More specifically, if tissues passed by emission light of one white light source have activities, the pixel array **131** can detect the motion artifact. Accordingly, employing only one white light source is sufficient, and it is not necessary to adopt multiple light sources each emitting light covering multiple wavelengths. It is also an option to arrange multiple white light sources surrounding the pixel array **131** to increase the detection possibility. In addition, as identical muscle fibers or muscle bundles are within a very small range, a distance D_r between two adjacent pixel regions A_{λ_1} to A_{λ_M} is preferably smaller than 2000 micrometers, for example 1500, 1200, 1000, 800 or 600 micrometers, to effectively cancel the motion artifact. For example, when different pixel regions A_{λ_1} to A_{λ_M} receive emergent light from different muscle fibers or bundles, the denosing function is degraded. Therefore, the region distance D_r is not simply a value of choice but with its physical meaning.

[0035] In another non-limiting embodiment, the pixel array **131'** of the light detector **13** is not divided into multiple pixel regions for detecting different light colors as shown in FIG. 2B. The multiple light detection signals associated with different light colors are detected by controlling the light source of multiple wavelengths to emit light of different colors at different times. For example, the light source **11** includes a single die which is controlled to emit light of different wavelengths by controlling its driving parameter (e.g., driving voltage or current) or by controlling a variable color filter covering on the single die. Or, the light source **11** includes multiple dies (e.g., shown as L_{λ_1} to L_{λ_M} in FIG. 2B) for emitting light containing or covering multiple wavelengths.

[0036] As mentioned above, to sense light from substantially identical muscle fibers or bundles, a die distance d_L between the multiple dies L_{λ_1} to L_{λ_M} in the light source **11** is preferably smaller than 2000 micrometers, e.g., the multiple dies being encapsulated within the same molding and on the same base layer, to allow the emission light therefrom to penetrate substantially identical muscle fibers or bundles to effectively cancel motion artifact caused by tiny activities. Similarly, the die distance d_L is not simply a value of choice but with its physical meaning. Similarly, the multiple dies

shown in FIG. 2B are selected to be arranged at a single side, two opposites sides or surrounding the pixel array **131'**.

[0037] The processor **15** performs a vector calculation between multiple current light detection signals (e.g., obtained in a working mode) and a pre-stored intensity distribution or ratio of different light colors (e.g., obtained in a register mode) to cancel the motion artifact, wherein the pre-stored intensity distribution or ratio of the different light colors is obtained and stored by using the single pixel array **131** or **131'** to detect multiple intensities of the multiple light detection signals $PPG_1, PPG_2 \dots PPG_M$ associated with the different light colors when the user is motionless (i.e., muscles under the detected skin having no activity). That is, the heart rate detection device **100** further has a memory (including a volatile memory and/or a non-volatile memory) for storing the intensity distribution or ratio as well as the algorithm and parameters required for operation.

[0038] Referring to FIGS. 3A and 3B, FIG. 3A is a flow chart of an operating method of a heart rate detection device according to one embodiment of the present disclosure which is applicable to the heart rate detection device **100** of FIGS. 1-3; and FIG. 3B is a schematic diagram of multiple light detection signals $PPG_1, PPG_2 \dots PPG_M$ (i.e., corresponding to λ_1 to λ_M) detected by a heart rate detection device according to one embodiment of the present disclosure. The operating method of this embodiment includes the steps of: entering a register mode (Step S31); creating registered data in the register mode (Step S32); entering a working mode (Step S33); performing a vector calculation between sample data and the registered data in the working mode (Step S34); and calculating a heart rate according to the vector calculated data (Step S35).

[0039] As mentioned above, the register mode is a detection mode that a user is motionless, e.g., a steady interval in FIG. 3B. For example, when the user executes an APP or presses a button on a heart rate detection device **100**, the heart rate detection device **100** enters the register mode. Meanwhile, the part of body of the user carrying the heart rate detection device **100** is completely steady so as to record registered data associated with different light colors. The registered data indicates the intensity distribution or ratio of light detection signals associated with different light colors when there is no motion artifact.

[0040] In the operating method of this embodiment, the working mode is referred to a mode that a user carries the heart rate detection device **100** in everyday life, e.g., a motion interval shown in FIG. 3B. The working mode is also entered when, for example, the user executes an APP or presses a button. If the light detection signals, which are detected in the working mode and contain the motion artifact, associated with different light colors are projected back to the pre-stored intensity distribution or ratio, the motion artifact can be removed.

[0041] Referring to FIGS. 1 and 3A-3B, details of FIG. 3A are described using an example below. The processor includes, for example, a normalizer, a filter and an intensity calculator.

[0042] Steps S31-S32: In the register mode, the processor **15** controls the light source **11** to illuminate a first skin surface of a user. Meanwhile, the pixel array **131** or **131'** of the light detector **13** senses emergent light from the first skin surface to generate multiple first light detection signals associated with different light colors, e.g., $PPG_1, PPG_2 \dots PPG_M$ shown in FIG. 3B, wherein the light detector **13**

acquires a plurality of sections of sample data associated with different light colors (illustrated by an example below) at a fixed or adjustable sampling frequency. The processor **15** then uses the plurality of sections of sample data associated with different light colors to calculate and store registered data, which reflects the intensity distribution or ratio of light of different colors.

[0043] For example, the processor **15** continuously receives the multiple first light detection signals $PPG_1, PPG_2, \dots, PPG_M$ associated with different light colors. In the present disclosure, each light detection signal among the multiple light detection signals detected by the light detector **13** is referred to one channel, and each channel is associated with one of the multiple different light colors. The processor **15** samples, within each sampling interval, a predetermined number of sample points (e.g., L points herein) each at a different time of every channel of the multiple first light detection signals $PPG_1, PPG_2, \dots, PPG_M$ as one section of sample data. It is appreciated that a light wavelength range of one channel herein includes not only a single wavelength but multiple wavelengths within a predetermined light wavelength range, e.g., full width at half maximum (FWHM).

[0044] For example, the L sample points of all M channels within one sampling interval acquired by the processor **15** are indicated by an $M \times L$ matrix as one section of sample data. As time goes by, the processor **15** acquires one $M \times L$ matrix within every sampling interval, and thus the processor **15** acquires a plurality of sections of sample data from every channel of the multiple first light detection signals $PPG_1, PPG_2, \dots, PPG_M$ associated with different light colors within a register interval (i.e. one register interval including a plurality of sampling intervals) to obtain a plurality of $M \times L$ matrices.

[0045] Next, the normalizer of the processor **15** normalizes every section of sample data (i.e. each $M \times L$ matrix) of the plurality of sections of sample data (i.e. the plurality of $M \times L$ matrices) of the multiple first light detection signals. For example, the normalization is to remove the dc component from each sampled value.

[0046] After the normalization, the processor **15** selects to filter each section of the normalized sample data. For example, the filter of the processor **15** uses a digital filter having a passband between 0.5 Hz and 3.5 Hz to filter each section of the normalized sample values.

[0047] Then, the intensity calculator of the processor **15** calculates an average of a standard deviation of the plurality of sections of sample data (e.g., **20** sections of sample data being acquired per second, and thus **600** sections being acquired for 30 seconds, but not limited to) of every channel within a register interval (a predetermined time interval, for example 30 seconds, but not limited to). Firstly, the processor **15** calculates a standard deviation of every section of sample data within the register interval. Then, the processor **15** calculates an average of the plurality of standard deviations of the plurality of sections of sample data of each channel.

[0048] Finally, the processor **15** obtains the intensity distribution of the calculated average values of every channel (e.g., PPG_1 - PPG_8 herein), which is used as the registered data associated with different light colors.

[0049] The processor further includes a vector calculator operates in the working mode.

[0050] Steps S33-S34: In the working mode, the processor **15** controls the light source **11** to illuminate a second skin surface of the user, wherein the second skin surface is identical to or different from the first skin surface. Meanwhile, the pixel array **131** or **131'** of the light detector **13** senses emergent light from the second skin surface to generate multiple second light detection signals associated with different light colors, e.g., $PPG_1, PPG_2, \dots, PPG_M$ as shown in FIG. 3B. It should be mentioned that methods of the pixel array **131** or **131'** of the light detector **13** for acquiring the multiple first light detection signals and the second light detection signals are identical only they are acquired in different modes (or referred to different stages or different time intervals).

[0051] Similarly, the processor **15** samples, within each sampling interval, a predetermined number of sample points (e.g., L points herein) each at a different time of every channel of the multiple second light detection signals $PPG_1, PPG_2, \dots, PPG_M$ as one section of sample data. For example, the processor **15** also acquires one $M \times L$ matrix for each sampling interval, wherein the method of the processor **15** for acquiring the $M \times L$ matrix has been mentioned above, and thus details thereof are not repeated herein.

[0052] The normalizer of the processor **15** normalizes every section of sample data (i.e. every $M \times L$ matrix) of the multiple second light detection signals $PPG_1, PPG_2, \dots, PPG_M$, and then the filter of the processor **15** filters every section of the normalized sample data, wherein the normalizing and the filtering are identical to those mentioned above and thus details thereof are not repeated herein. It should be mentioned that the filters herein are used for improving the calculation accuracy, but the filters are not necessary to be implemented.

[0053] Next, the vector calculator of the processor **15** performs a vector calculation between every section of sample data (i.e. $R_{M \times L}$) of the multiple second light detection signals and the registered data to cancel the motion artifact. For example, P is vector calculated data. In the working mode, the processor **15** outputs one set of heart rate data P , e.g., P_1, P_2, P_3, \dots as shown in FIG. 4, every one sampling interval, wherein the motion artifact no longer exists in the vector calculated data P . FIG. 4 shows the processor **15** outputs a plurality of vector calculated data P at continuous times (shown by $n=0, 1, 2, \dots$). A data number of each data set P is identical to a sampling number L within each sampling interval acquired by the processor **15**.

[0054] In the present disclosure, the processor **15** samples a plurality of sections of sample data (i.e. a plurality of $M \times L$ matrices) in the register mode for creating the registered data, but samples one section of sample data (i.e. one $M \times L$ matrix) every sampling period in the working mode for the vector calculation with the registered data.

[0055] It is appreciated that channel numbers M of the multiple first detection signals and the multiple second detection signals are identical so as to perform the vector calculation. In one non-limiting embodiment, in the register mode the processor **15** uses more channels (e.g., 8 channels corresponding to 8 light colors 430 nm, 460 nm, 490 nm, 515 nm, 560 nm, 615 nm, 660 nm and 695 nm, but not limited to) to construct the registered data, and less channels are used in the working mode (e.g., 3 channels corresponding to 3 light colors 430 nm, 560 nm and 695 nm, but not limited to). The processor **15** only reads required data from the memory **17** during accessing the registered data. For

example, in the working mode, when the detection result calculated by using one group of channels is not correct, e.g., noises still too high, another group of channels are used, by increasing, decreasing or maintaining the channel number. In other embodiments, channels among the multiple channels to be used are selected according to a ratio between the AC value and DC value of a PPG signal (referred as PI value herein), wherein a higher PI value indicates that a tissue response to the emission light is better. For example, a channel having a highest PI value is used in conjunction with the channel having a lowest PI value for the denoising process.

[0056] Finally, in the working mode, the processor 15 calculates a heart rate using the vector calculated data P in the time domain or frequency domain. For example, the processor 15 calculates the heart rate according to a time interval between two adjacent peaks or other corresponding kink points in the vector calculated data P, or the processor 15 converts the vector calculated data P into the frequency domain at first and then calculates the heart rate accordingly.

[0057] In one non-limiting embodiment, as the sampling frequency (or frame rate) of the light detector 13 is higher than the heart rate, to increase the signal intensity, the processor 15 further adds or overlaps a predetermined number of vector calculated data P or the vector calculated data P within a predetermined interval at first (e.g., P1+P2+P3+ . . . in a section by section manner), and then calculates a heart rate according to a sum of or the overlapped vector calculated data P.

[0058] It should be mentioned that although the above operating method is illustrated in a way that multiple functional blocks are used to perform different functions, functions performed by every functional block are considered to be performed by the processor 15 using software codes and/or hardware codes.

[0059] As mentioned above, the registered data is the intensity distribution or ratio of light detection signals associated with every light color without the motion artifact (e.g., the steady interval shown in FIG. 3B). In actual operation if the user has some activities (e.g., the motion interval shown in FIG. 3B), the data intensity in the sampling matrix $R_{M \times L}$ of the second light detection signals is influenced by the noise to deviate from the pre-stored intensity distribution or ratio. The vector calculation of the present disclosure is to cause intensities of different light colors of the sampling matrix $R_{M \times L}$ to be projected to the pre-stored intensity distribution or ratio to remove the motion artifact.

[0060] In one non-limiting embodiment, the heart rate detection device of the present disclosure further includes a display (not shown) for showing the value and/or waveform of the heart rate.

[0061] It should be mentioned that the operating method of FIG. 3A mentioned above is only one embodiment applicable to the heart rate detection device 100, but not used to limit the present disclosure. The heart rate detection device 100 may use other algorithms to cancel noises as long as the light detector 13 detects emergent light from substantially identical muscle fibers or bundles, e.g., subtracting multiple light detection signals associated with different light colors from each other to remove the motion artifact.

[0062] It is appreciated that values mentioned in the above embodiments, such as light wavelengths, a number of light

sources, a number of sampled points, a number of channels, are only intended to illustrate but not to limit the present disclosure.

[0063] A person skilled in the art would know that using white light has a poor efficiency, and thus a white light source is not applied to the physiological detection system. Meanwhile, according to the characteristics of luminescence materials, a monochromatic LED for emitting yellow light between 570 nm and 620 nm does not have high emission efficiency (i.e. consuming more power). Accordingly, although a PPG signal response (i.e. the above PI value) to light between 570 nm and 620 nm is better than to green light, the PI value is sacrificed and a green light source having better emission efficiency is selected to prevent using a yellow light source due to its high power consumption. To increase the PI value and reduce the power consumption (i.e. achieve high emission efficiency) at the same time, in one embodiment of the present disclosure, a white light source having a color temperature between 2800K and 3200K is used. Meanwhile, a filter layer having a pass band between 570 nm and 620 nm is covered on a pixel array of the light detector for filtering white light emitted by the white light source. In this way, the purposes of high PI value and low power consumption are achieved at the same time. For example, for detecting same PI values, using a white LED having a color temperature between 2800K and 3200K can have about three times of the emission efficiency than using the green LED or yellow LED. A significant improvement is achieved.

[0064] In addition, an optical component is not used to constrain an emission angle of a white LED because the use purpose of the white LED is for space illumination such that a wide emission angle is required. Please referring to FIG. 5, to further improve the detection efficiency, a plastic or glass molding 71 is further formed on the white LED to cover a die 73 which is arranged on a base layer 75 of the white LED to constrain an emission angle θ of the white LED to be within 60 and 80 degrees to improve the system efficiency.

[0065] As mentioned above, the conventional physiological detection device can only cancel noises caused by stronger exercises but is not able to eliminate motion artifact caused by tiny muscle activities (e.g., those undetectable by an acceleration detector). Accordingly, the present disclosure further provides a heart rate detection device (e.g., FIGS. 1 and 2A-2B) and an operating method thereof (e.g., FIG. 3A) that use a single pixel array to detect reflected and scattered light from subcutaneous tissues illuminated by a light source, which emits light covering multiple wavelengths, to generate multiple light detection signals associated with different wavelengths. Based on an assumption that muscle activities have substantially identical influences on light detection signals of every light wavelength, the present disclosure cancel the motion artifact between light detection signals of different light wavelengths by, for example calculating the subtraction therebetween or vector projection, to obtain a clean heart rate waveform. This clear heart rate waveform can be used to calculate more correct heart rates.

[0066] Although the disclosure has been explained in relation to its preferred embodiment, it is not used to limit the disclosure. It is to be understood that many other possible modifications and variations can be made by those

skilled in the art without departing from the spirit and scope of the disclosure as hereinafter claimed.

What is claimed is:

1. A heart rate detection device, comprising:
 - at least one light source each configured to emit light covering multiple wavelengths to illuminate a skin surface of a user;
 - a light detector comprising a sensing unit configured to sense emergent light from the skin surface and output multiple light detection signals associated with different light colors corresponding to the multiple wavelengths; and
 - a processor configured to perform a vector calculation between the multiple light detection signals and a pre-stored intensity distribution of the different light colors to remove a motion artifact.
2. The heart rate detection device as claimed in claim 1, wherein
 - each of the light source is a white light source, and
 - the sensing unit is a single pixel array which comprises multiple pixel regions each covered by a filter layer of one of the different light colors to cause the multiple pixel regions of the single pixel array to output the multiple light detection signals associated with the different light colors.
3. The heart rate detection device as claimed in claim 2, wherein a distance between the multiple pixel regions is smaller than 2000 micrometers.
4. The heart rate detection device as claimed in claim 1, wherein a wavelength difference between the different light colors is at least 25 nm.
5. The heart rate detection device as claimed in claim 1, wherein
 - the light source comprises multiple dies configured to illuminate the light covering multiple wavelengths, and
 - a die distance between the multiple dies is smaller than 2000 micrometers.
6. The heart rate detection device as claimed in claim 1, wherein the pre-stored intensity distribution of the different light colors is obtained and stored by using the sensing unit to detect multiple intensities of the multiple light detection signals associated with the different light colors when the user is motionless.
7. The heart rate detection device as claimed in claim 1, wherein a channel number of the multiple light detection signals is identical to that of the pre-stored intensity distribution of the different light colors.
8. The heart rate detection device as claimed in claim 1, comprising two light sources of the multiple wavelengths arranged at two opposite sides along a first direction of the light detector.
9. The heart rate detection device as claimed in claim 1, comprising four light sources of the multiple wavelengths, wherein
 - two light sources among the four light sources are arranged at two opposite sides along a first direction of the light detector, and
 - the rest two light sources among the four light sources are arranged at two opposite sides along a second direction of the light detector.
10. An operating method of a heart rate detection device, the heart rate detection device comprising a light source of multiple wavelengths, a light detector and a processor, the operating method comprising:

- entering a register mode, the register mode comprising:
 - illuminating, by the light source, a first skin surface of a user;
 - sensing, by the light detector, emergent light from the first skin surface to generate multiple first light detection signals associated with different light colors; and
 - calculating and storing, by the processor, registered data of a plurality of sections of sample data associated with the different light colors; and
- entering a working mode, the working mode comprising:
 - illuminating, by the light source, a second skin surface of a user;
 - sensing, by the light detector, emergent light from the second skin surface to generate multiple second light detection signals associated with the different light colors; and
 - performing, by the processor, a vector calculation between every section of sample data of the multiple second light detection signals and the registered data to remove a motion artifact.
11. The operating method as claimed in claim 10, wherein calculating the registered data comprises:
 - sampling, by the processor within a register interval, the plurality of sections of sample data on every channel of the multiple first light detection signals associated with the different light colors;
 - calculating, by the processor, an average of a standard deviation of the plurality of sections of sample data of every channel within the register interval; and
 - taking multiple average values of different channels as the registered data associated with the different light colors.
12. The operating method as claimed in claim 11, wherein before calculating the average of the standard deviation further comprises:
 - normalizing, by the processor, each section of sample data of the plurality of sections of sample data of the multiple first light detection signals; and
 - filtering, by the processor, each section of the normalized sample data.
13. The operating method as claimed in claim 10, wherein performing the vector calculation further comprises:
 - calculating, by the processor, a covariance matrix of the every section of sample data of the multiple second light detection signals; and
 - performing, by the processor, a multiplication on a transfer matrix of the registered data, a reciprocal of the covariance matrix and the every section of sample data of the multiple second light detection signals.
14. The operating method as claimed in claim 13, wherein before performing the vector calculation further comprises:
 - normalizing, by the processor, the every section of sample data of the multiple second light detection signals; and
 - filtering, by the processor, each section of the normalized sample data.
15. The operating method as claimed in claim 10, wherein a channel number of the multiple first light detection signals is identical to that of the multiple second light detection signals, and each channel is associated with one of the different light colors.
16. The operating method as claimed in claim 15, wherein the processor samples, within each sampling interval, a

predetermined number of sample points each at a different time of the each channel of the multiple first light detection signals and the multiple second light detection signals as one section of sample data.

17. The operating method as claimed in claim **10**, further comprising:

adding, by the processor in the working mode, the vector calculated data associated with a plurality of sections of sample data of the multiple second light detection signals.

18. The operating method as claimed in claim **10**, further comprising:

calculating, by the processor in the working mode, a heart rate in time domain or frequency domain using the vector calculated data associated with a plurality of sections of sample data of the multiple second light detection signals.

19. The operating method as claimed in claim **10**, wherein the register mode is a detection mode during which the user is motionless.

20. A physiological detection device, comprising:

a white light source configured to emit white light having a color temperature between 2800K and 3200K;

a molding formed upon the white light source and configured to constrain an emission angle of the white light between 60 and 80 degrees; and

a pixel array covered by a filter layer having a passband between 570 nm and 610 nm configured to filter the white light.

* * * * *

专利名称(译)	心率检测装置及其操作方法，生理检测装置		
公开(公告)号	US20200138380A1	公开(公告)日	2020-05-07
申请号	US16/177433	申请日	2018-11-01
[标]申请(专利权)人(译)	原相科技股份有限公司		
申请(专利权)人(译)	PIXART IMAGING INC.		
当前申请(专利权)人(译)	PIXART IMAGING INC.		
[标]发明人	GU REN HAU LIN CHIH HSIN		
发明人	GU, REN-HAU LIN, CHIH-HSIN		
IPC分类号	A61B5/00 A61B5/024		
CPC分类号	A61M2205/3303 A61B5/02405 A61B5/02416 A61B5/7207 A61B5/02438 A61B5/0408 A61B5/0006 A61B5/0245 A61B5/0064 A61B5/02433 A61B5/7214 A61B5/7264 A61B2562/066		
外部链接	Espacenet USPTO		

摘要(译)

提供了一种心率检测装置，其包括感测单元，该感测单元用于感测来自多种光色的单个光源照射的皮下组织的出射光，以输出与多个波长相关的多个光检测信号。心率检测装置还包括处理器，该处理器使用与多个波长相关联的多个光检测信号来消除运动伪影以获得干净的心率信号。

