



(19) **United States**

(12) **Patent Application Publication**
Chen et al.

(10) **Pub. No.: US 2018/0184931 A1**
(43) **Pub. Date: Jul. 5, 2018**

(54) **AUTOMATED ECG ANALYSIS AND DIAGNOSIS SYSTEM**

Publication Classification

(71) Applicants: **Guangren Chen**, Acadia, CA (US);
Rong Yang, Porter Ranch, CA (US);
Zhongnong Jiang, Richardson, TX (US)

(51) **Int. Cl.**
A61B 5/04 (2006.01)
A61B 5/0468 (2006.01)
A61B 5/00 (2006.01)
A61B 5/0464 (2006.01)
A61B 5/046 (2006.01)

(72) Inventors: **Guangren Chen**, Acadia, CA (US);
Rong Yang, Porter Ranch, CA (US);
Zhongnong Jiang, Richardson, TX (US)

(52) **U.S. Cl.**
CPC *A61B 5/04012* (2013.01); *A61B 5/0468* (2013.01); *A61B 5/725* (2013.01); *A61B 5/0408* (2013.01); *A61B 5/046* (2013.01); *A61B 5/7257* (2013.01); *A61B 5/0464* (2013.01)

(21) Appl. No.: **15/904,543**

(22) Filed: **Feb. 26, 2018**

(57) **ABSTRACT**

Related U.S. Application Data

(63) Continuation-in-part of application No. 15/393,135, filed on Dec. 28, 2016, which is a continuation-in-part of application No. 14/749,697, filed on Jun. 25, 2015, now Pat. No. 9,538,930, said application No. 14/749,697 is a continuation-in-part of application No. 14/662,996, filed on Mar. 19, 2015, now Pat. No. 9,339,204, said application No. 14/662,996 is a continuation of application No. PCT/US15/20828, filed on Mar. 16, 2015.

An ECG system identifies and annotates cardiac electrophysiological signals in an ECG waveform from harmonic waveforms. Electrical impulses are received from a beating heart. The electrical impulses are converted to an ECG waveform. The ECG waveform is converted to a frequency domain waveform, which, in turn, is separated into two or more different frequency domain waveforms, which, in turn, are converted into a plurality of time domain cardiac electrophysiological subwaveforms and discontinuity points between these subwaveforms. The plurality of subwaveforms and discontinuity points are compared to a database of subwaveforms and discontinuity points for normal and abnormal patients. At least one subwaveform or one or more discontinuity points are identified as a normal or abnormal electrophysiological signal of the ECG waveform from the comparison. The ECG waveform is displayed along with one or more markers at a location of the at least one subwaveform or one or more discontinuity points.

(60) Provisional application No. 62/463,662, filed on Feb. 26, 2017, provisional application No. 62/271,704, filed on Dec. 28, 2015, provisional application No. 62/271,699, filed on Dec. 28, 2015, provisional application No. 62/017,185, filed on Jun. 25, 2014, provisional application No. 62/008,435, filed on Jun. 5, 2014.

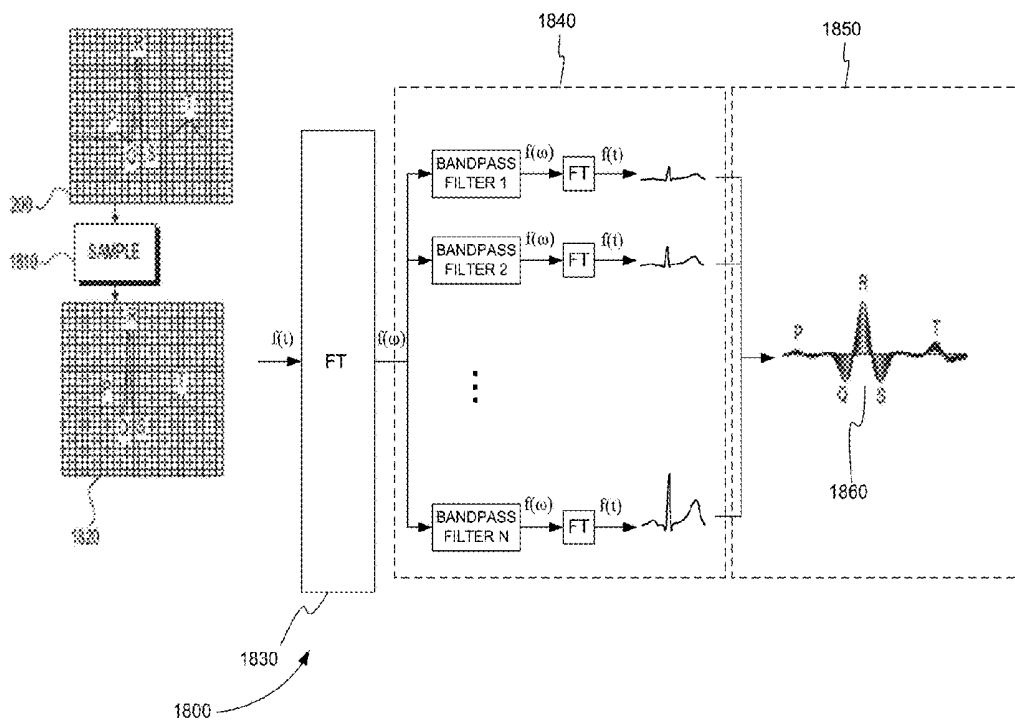

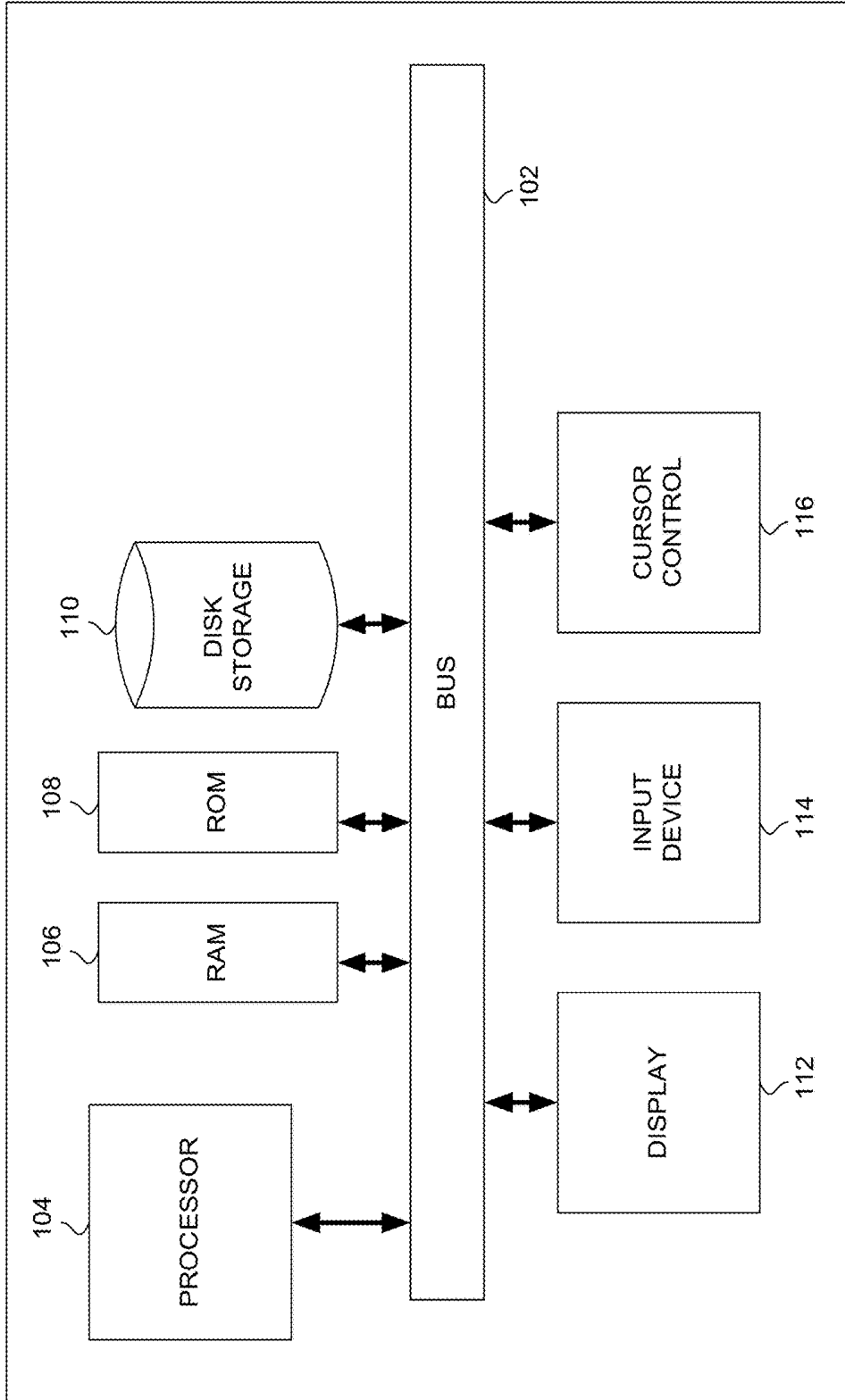
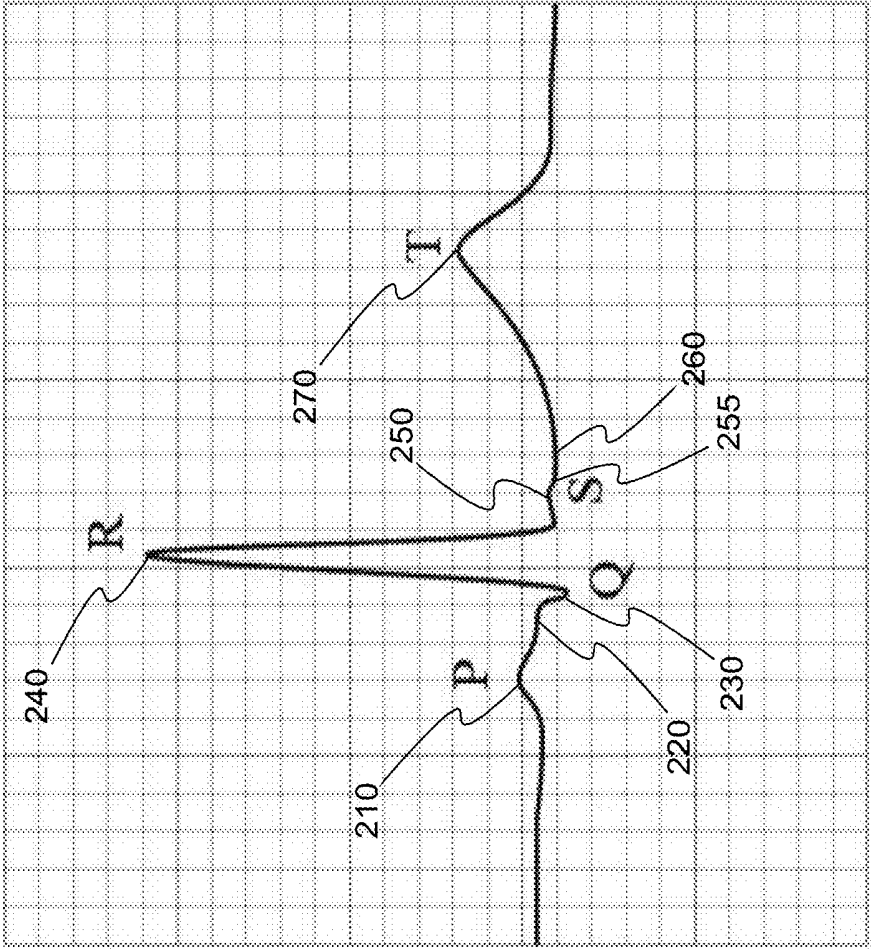

FIG. 1

100



(PRIOR ART)

FIG. 2

200

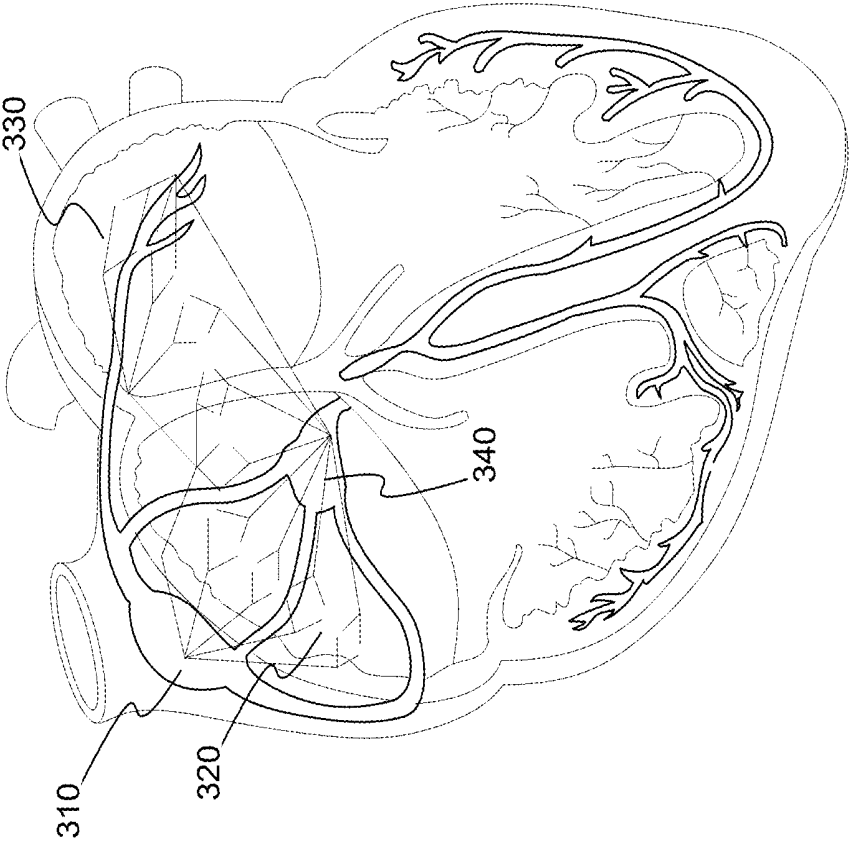

FIG. 3

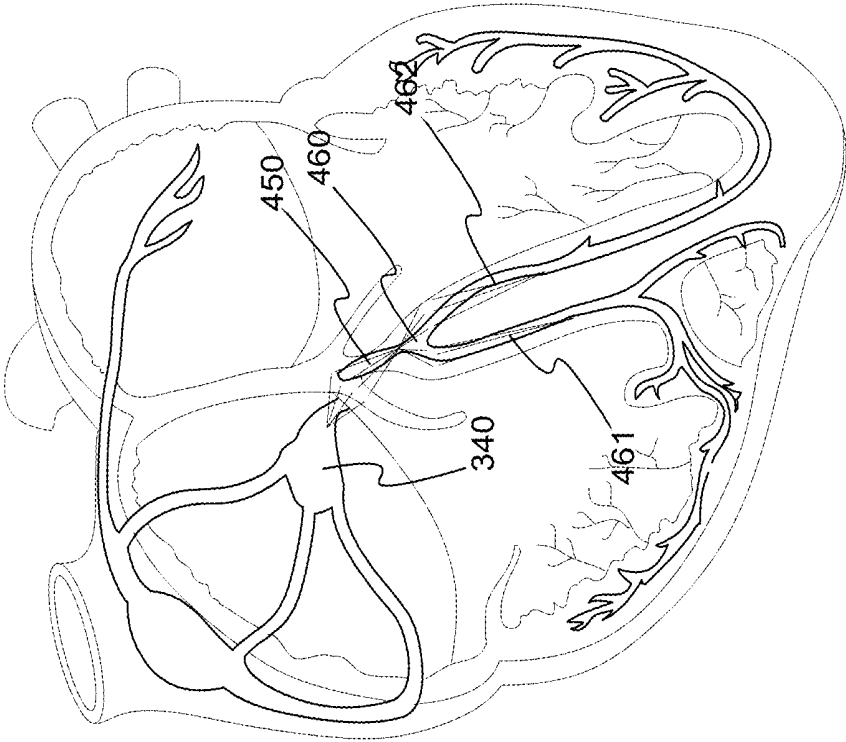

FIG. 4



400

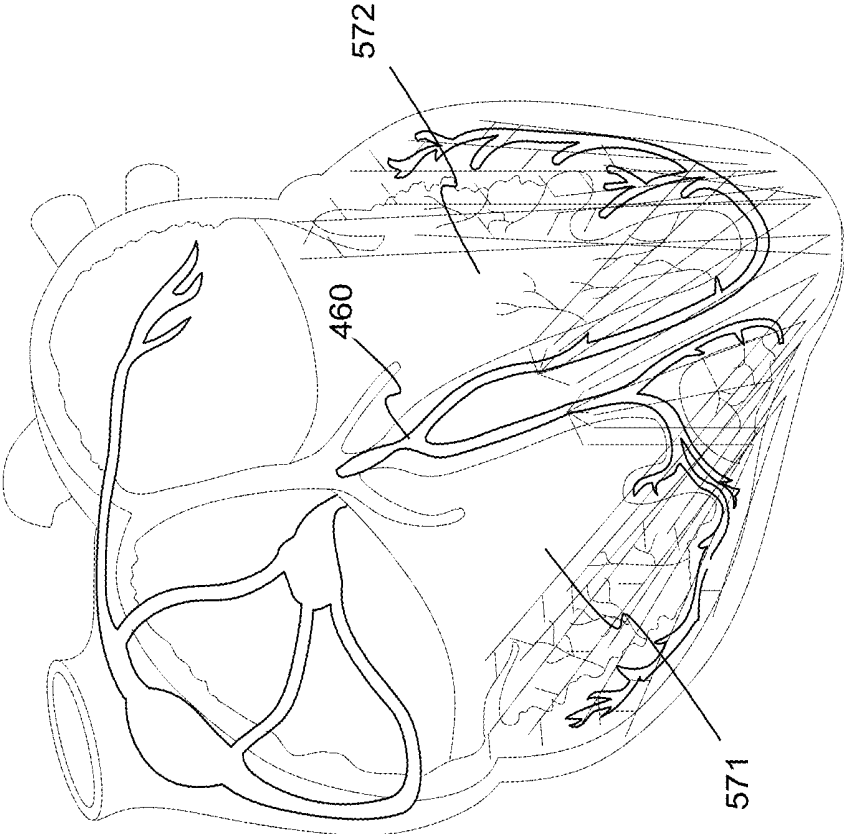

FIG. 5



500

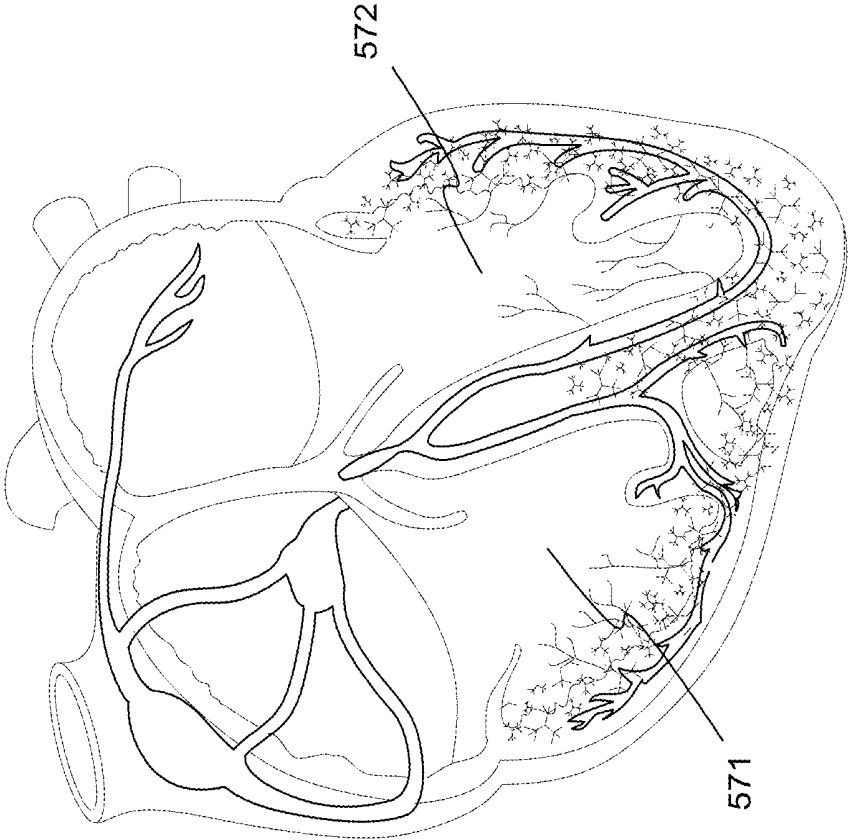
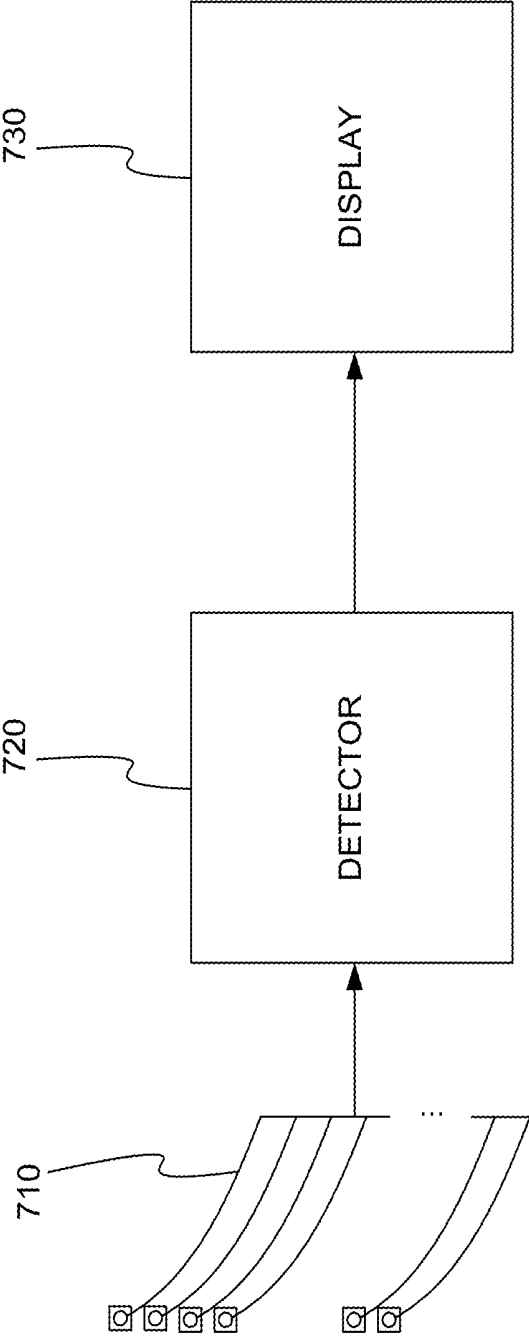

FIG. 6



600



(PRIOR ART)

FIG. 7

700

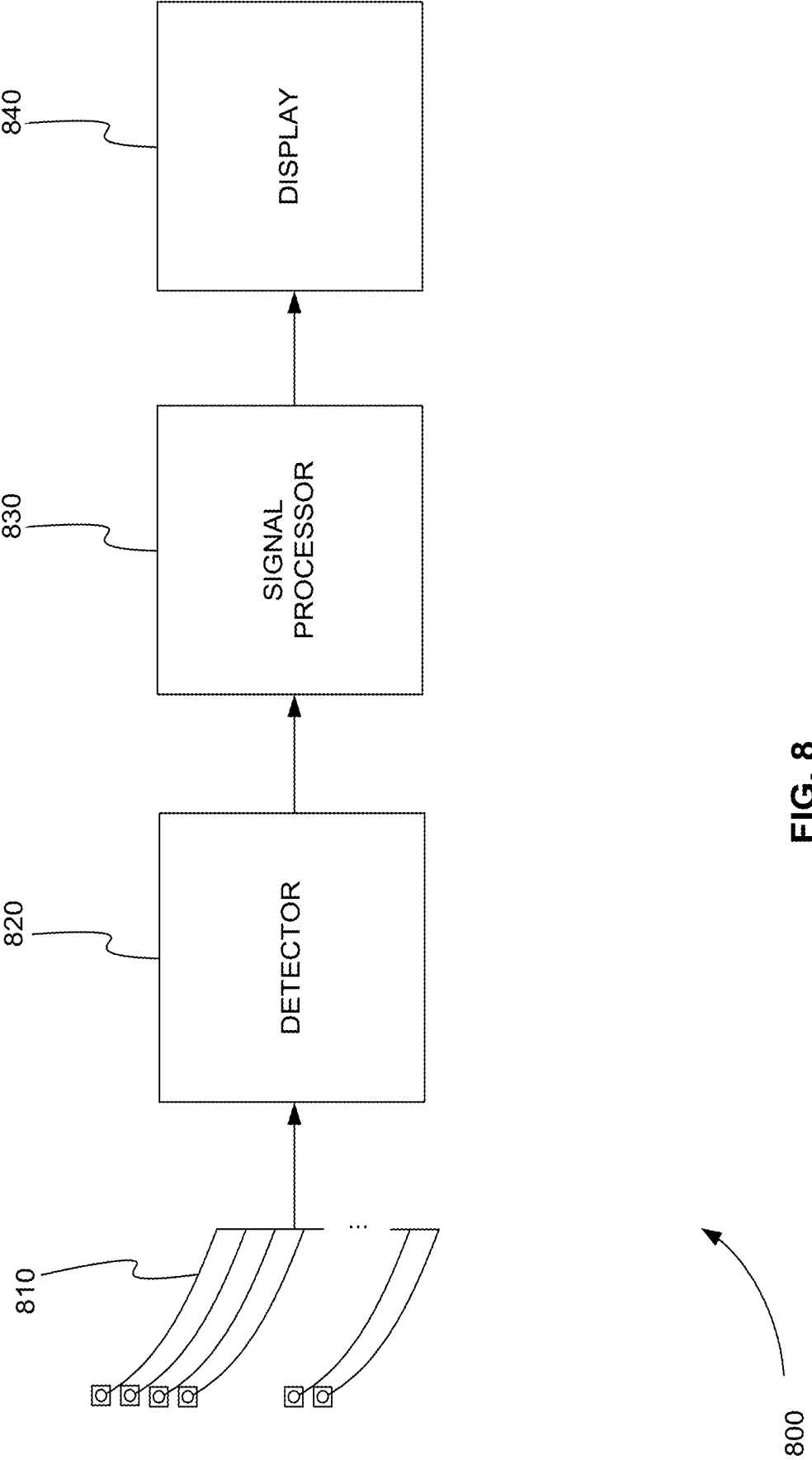

FIG. 8

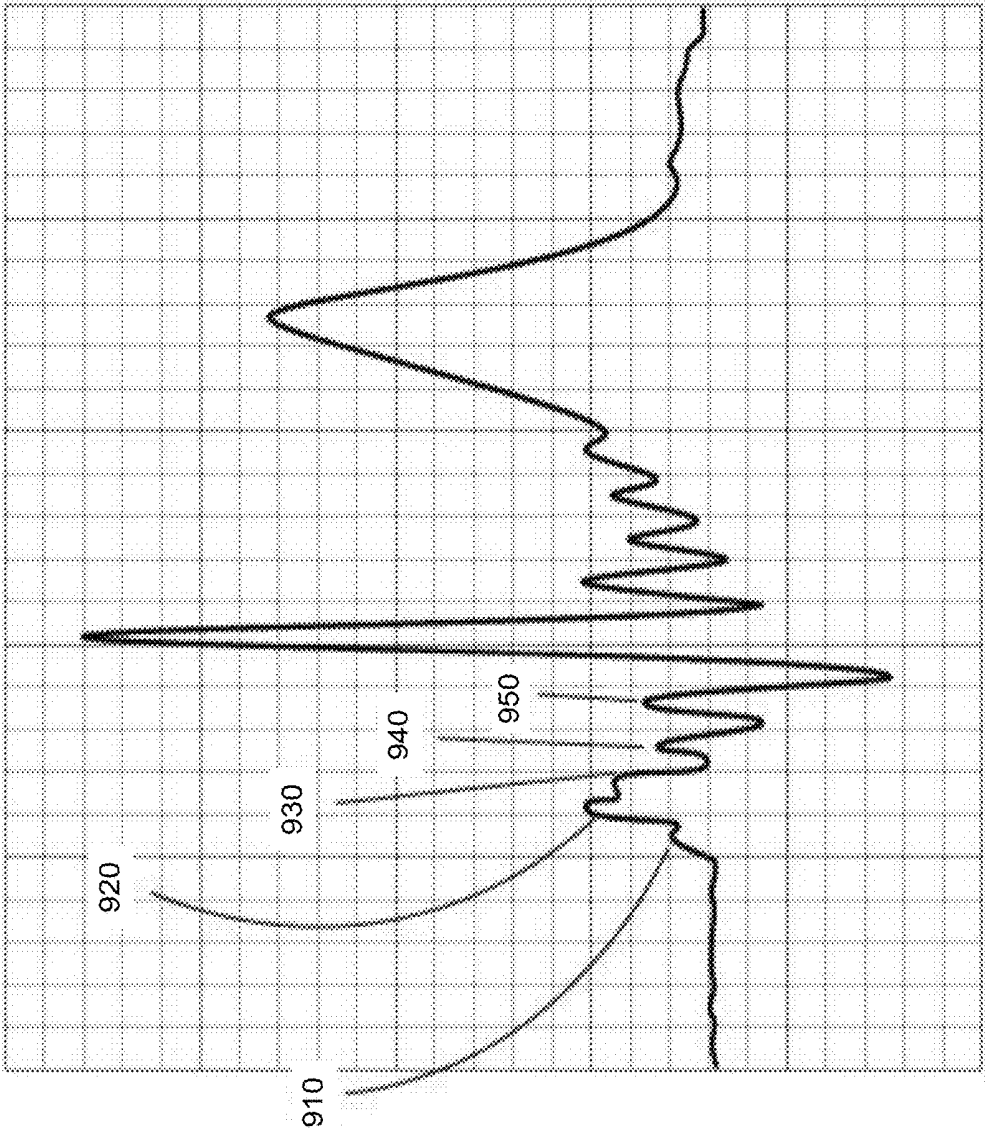
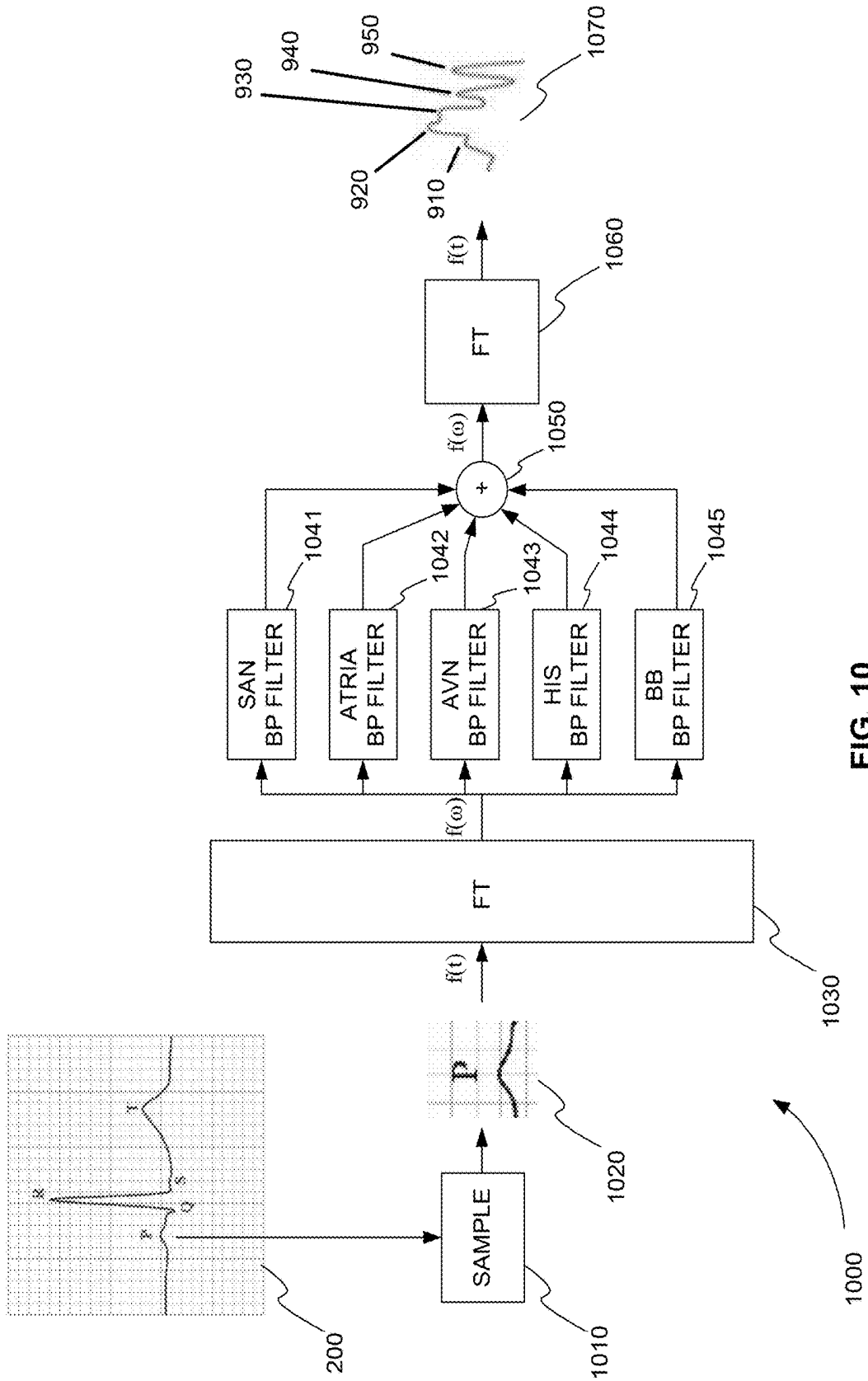

FIG. 9

900



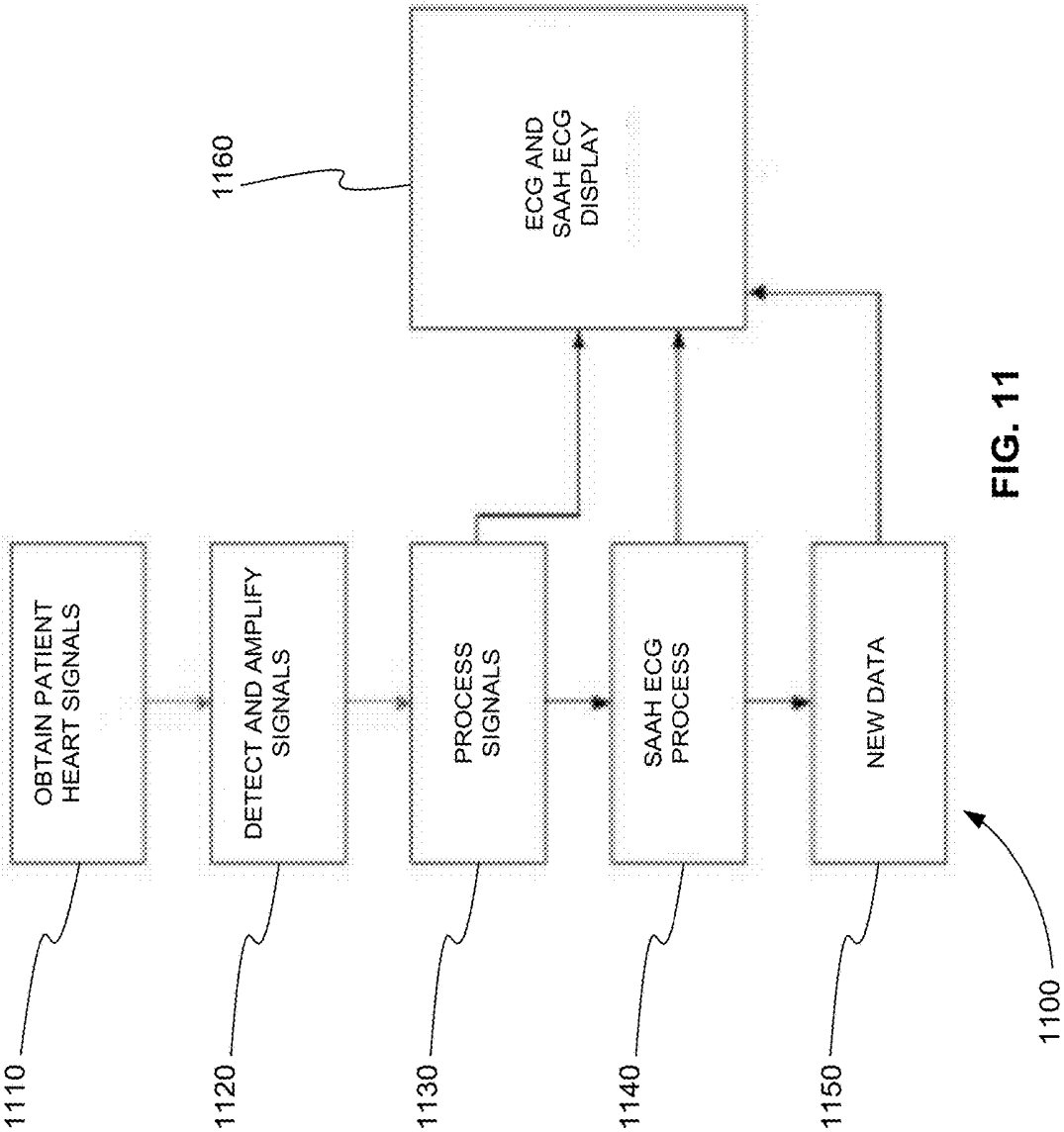

FIG. 11

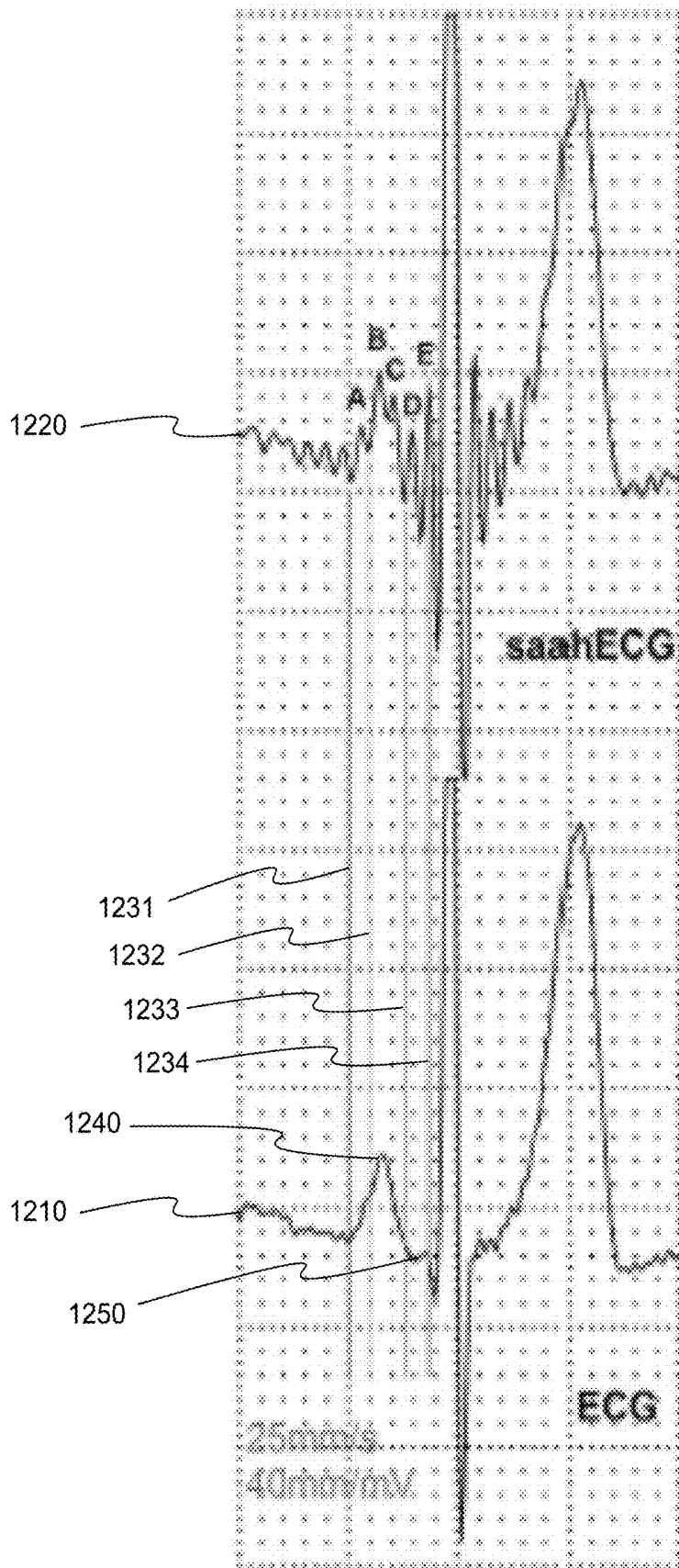

FIG. 12

1200

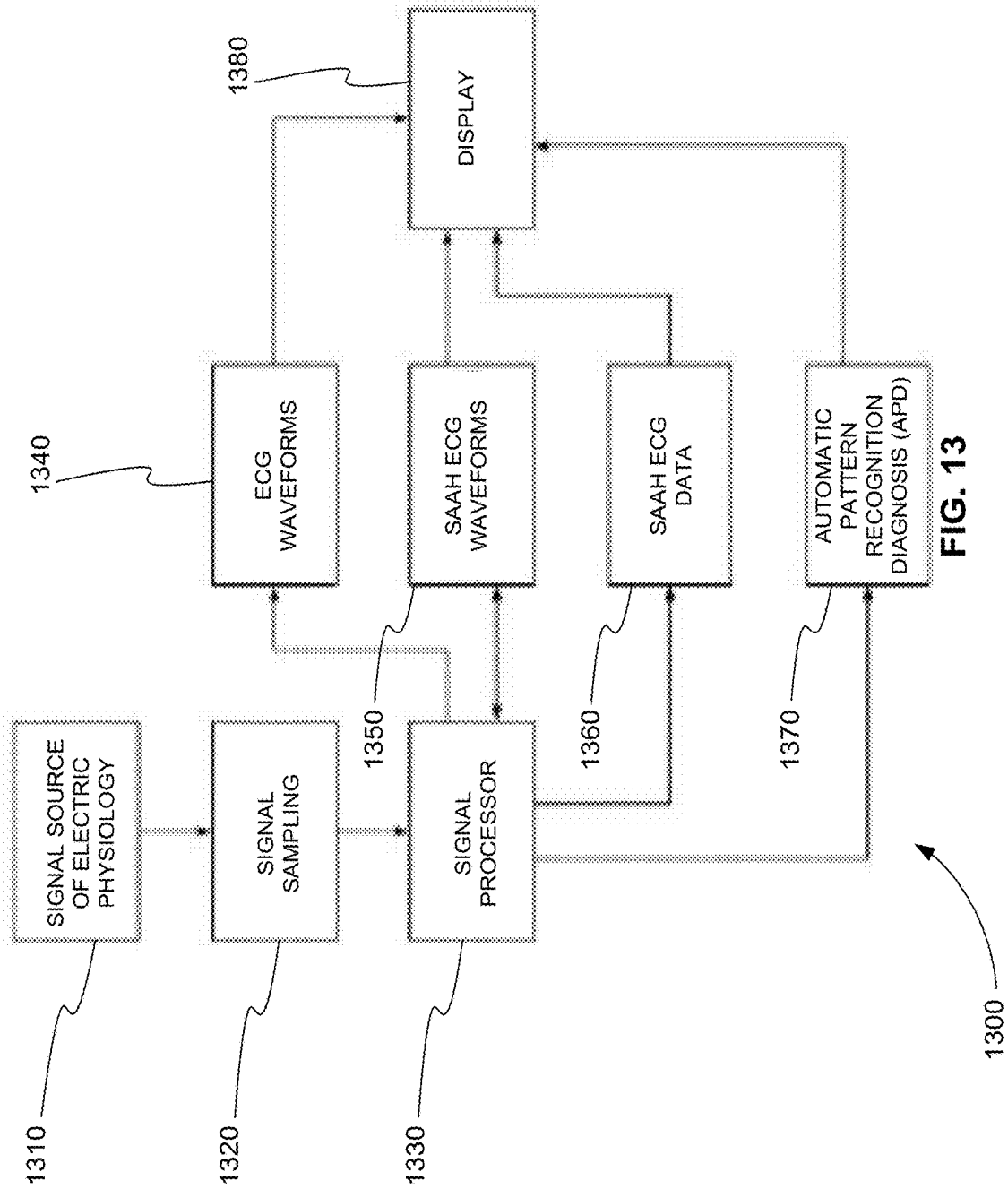
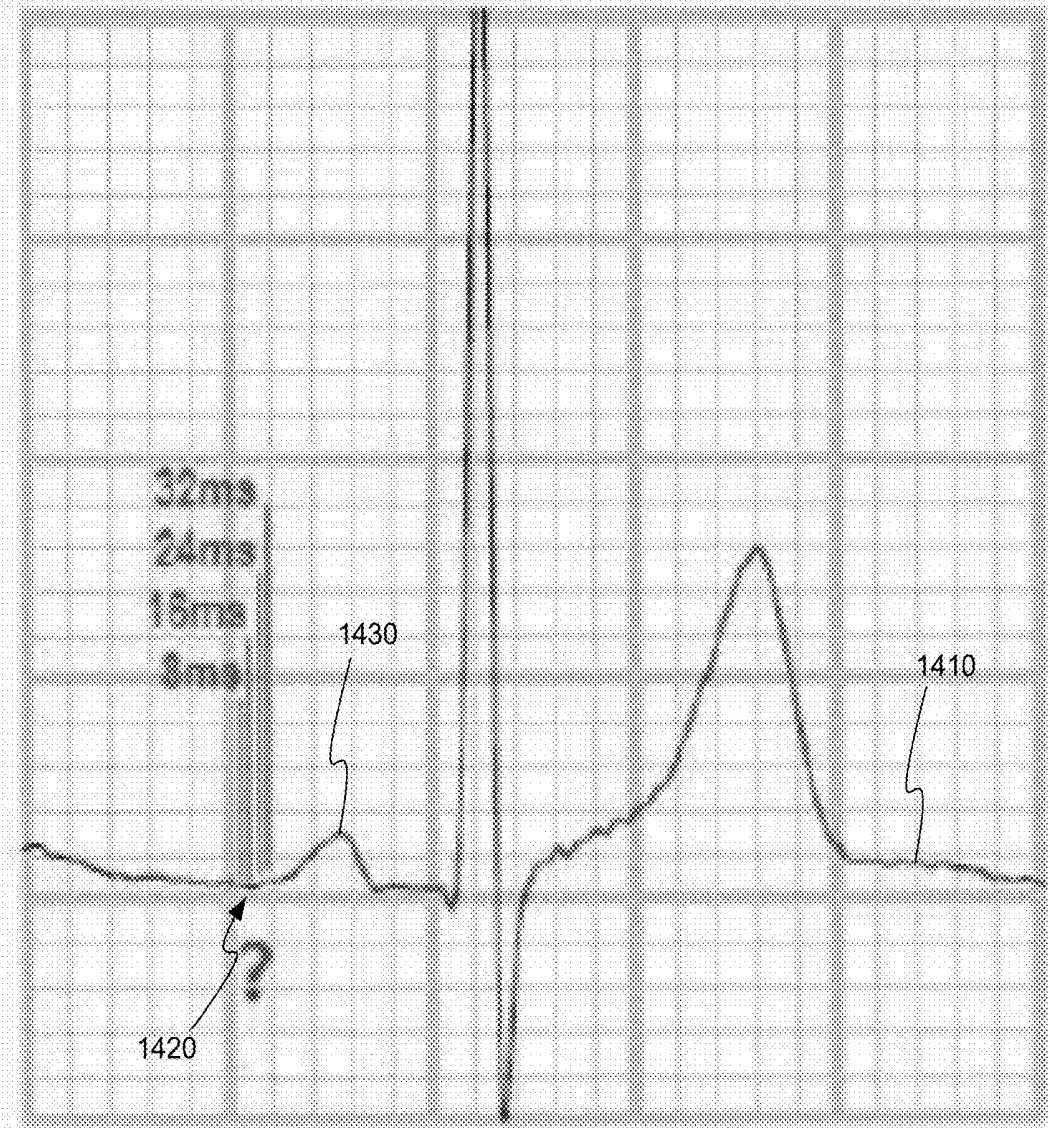
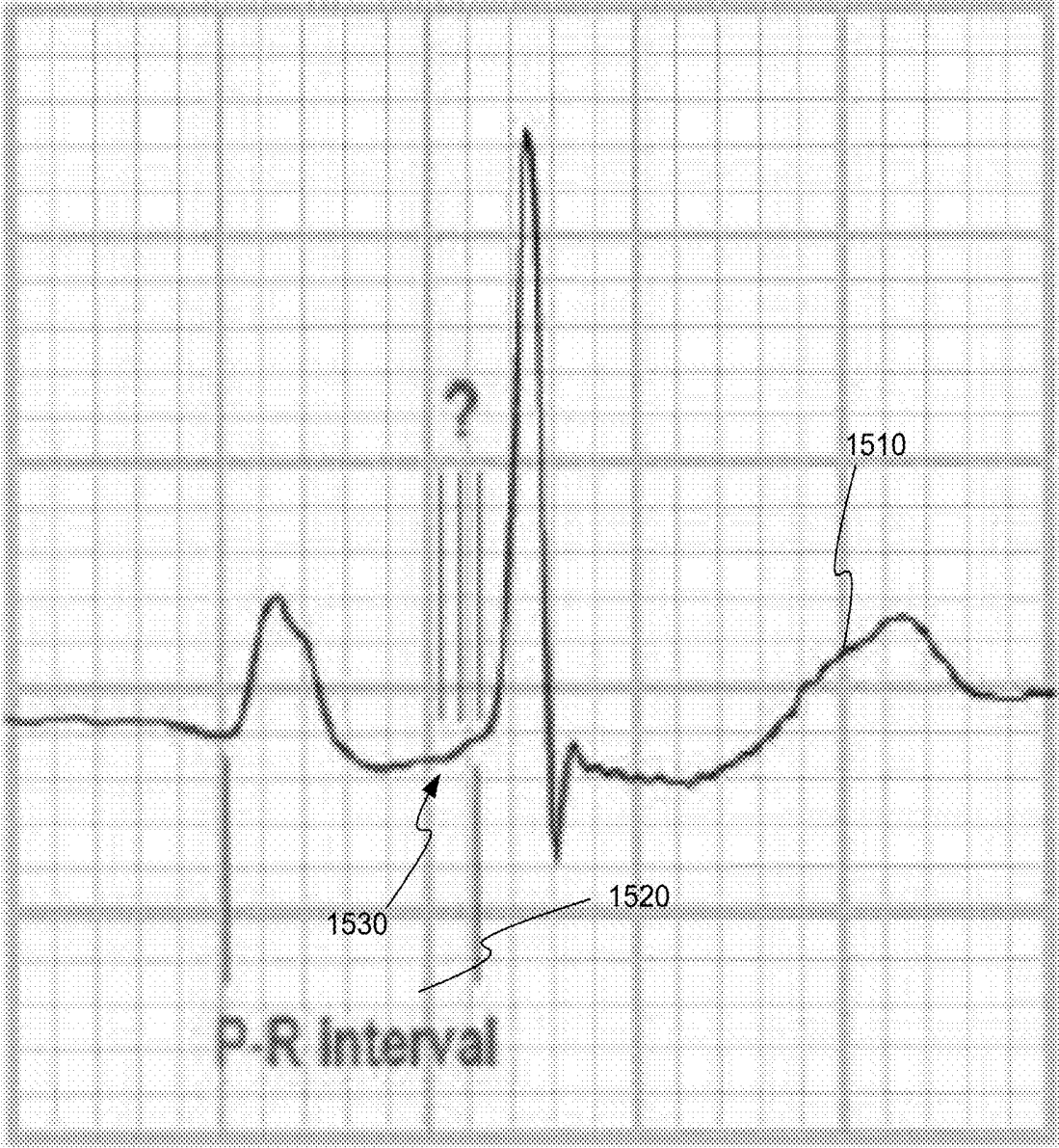

FIG. 13



1400 →

FIG. 14



1500 →

FIG. 15

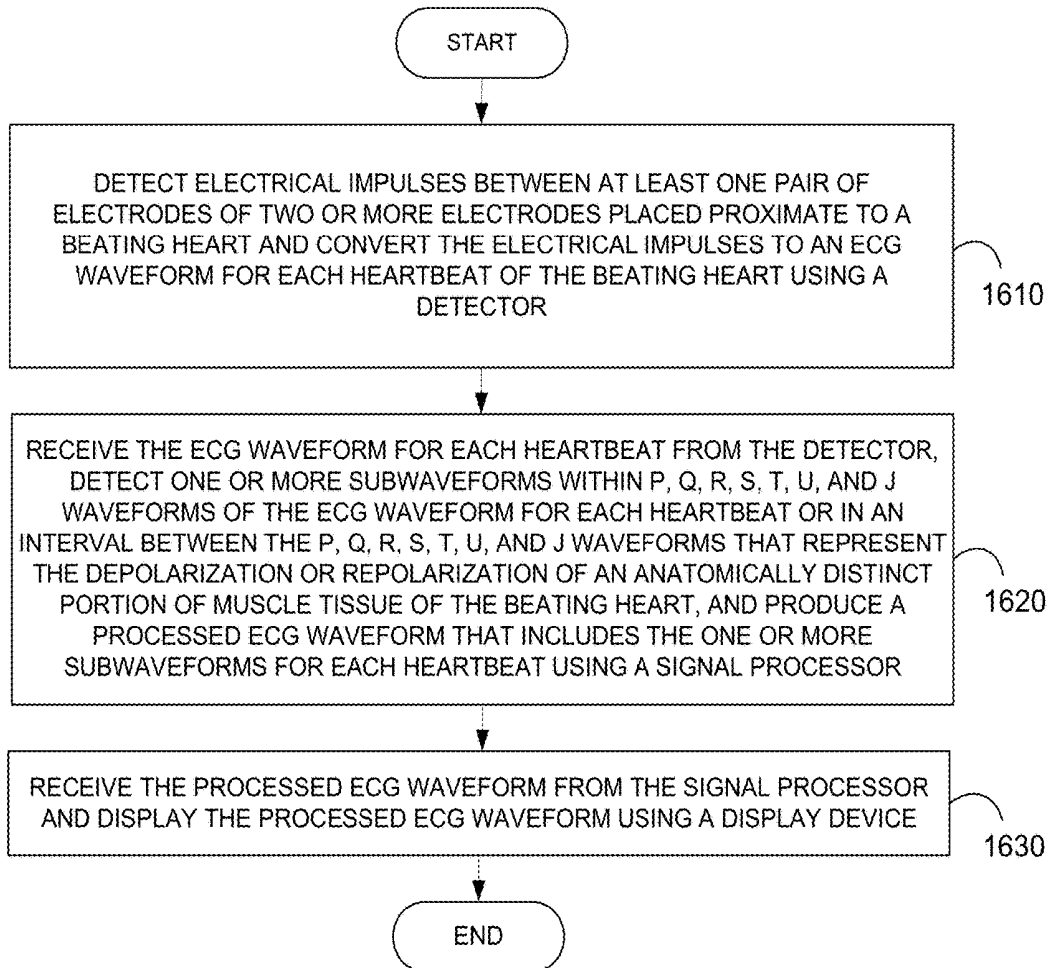

1600

FIG. 16

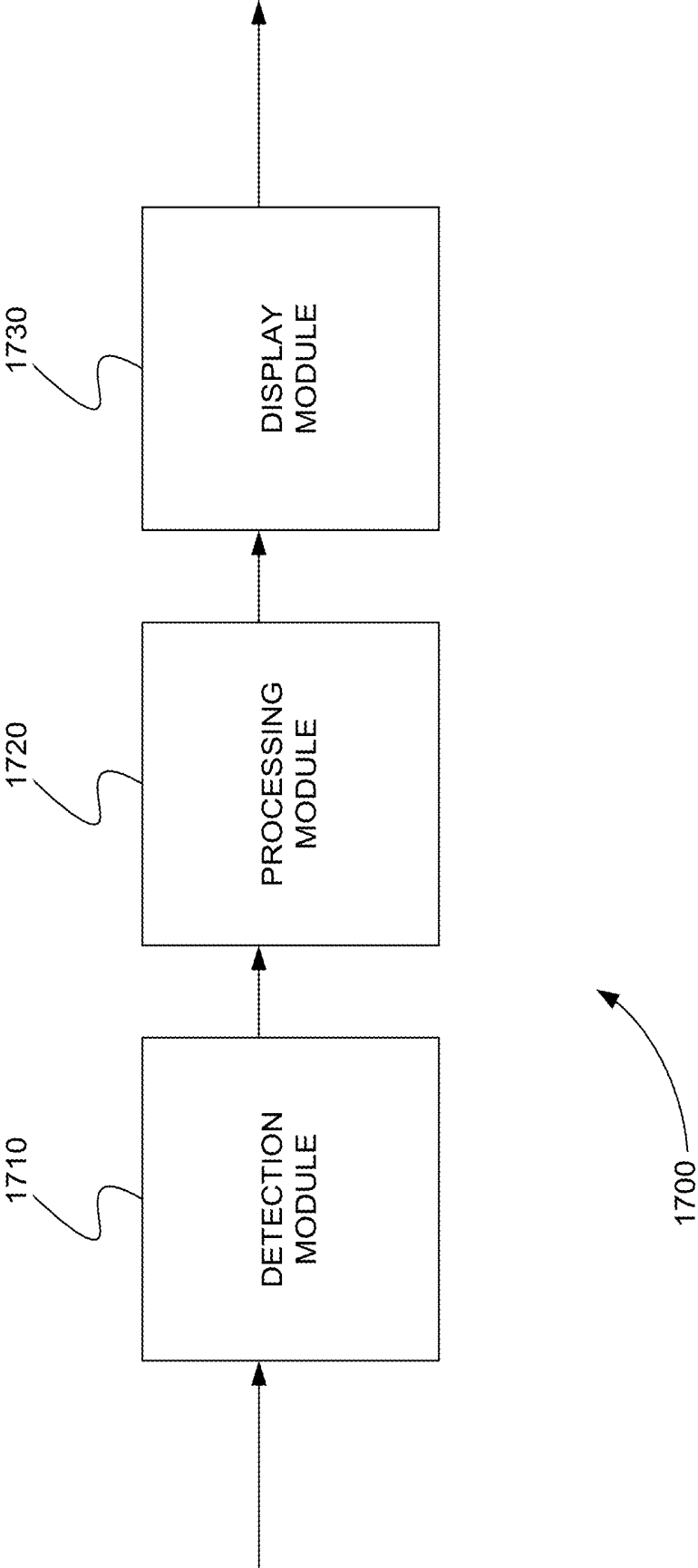

FIG. 17

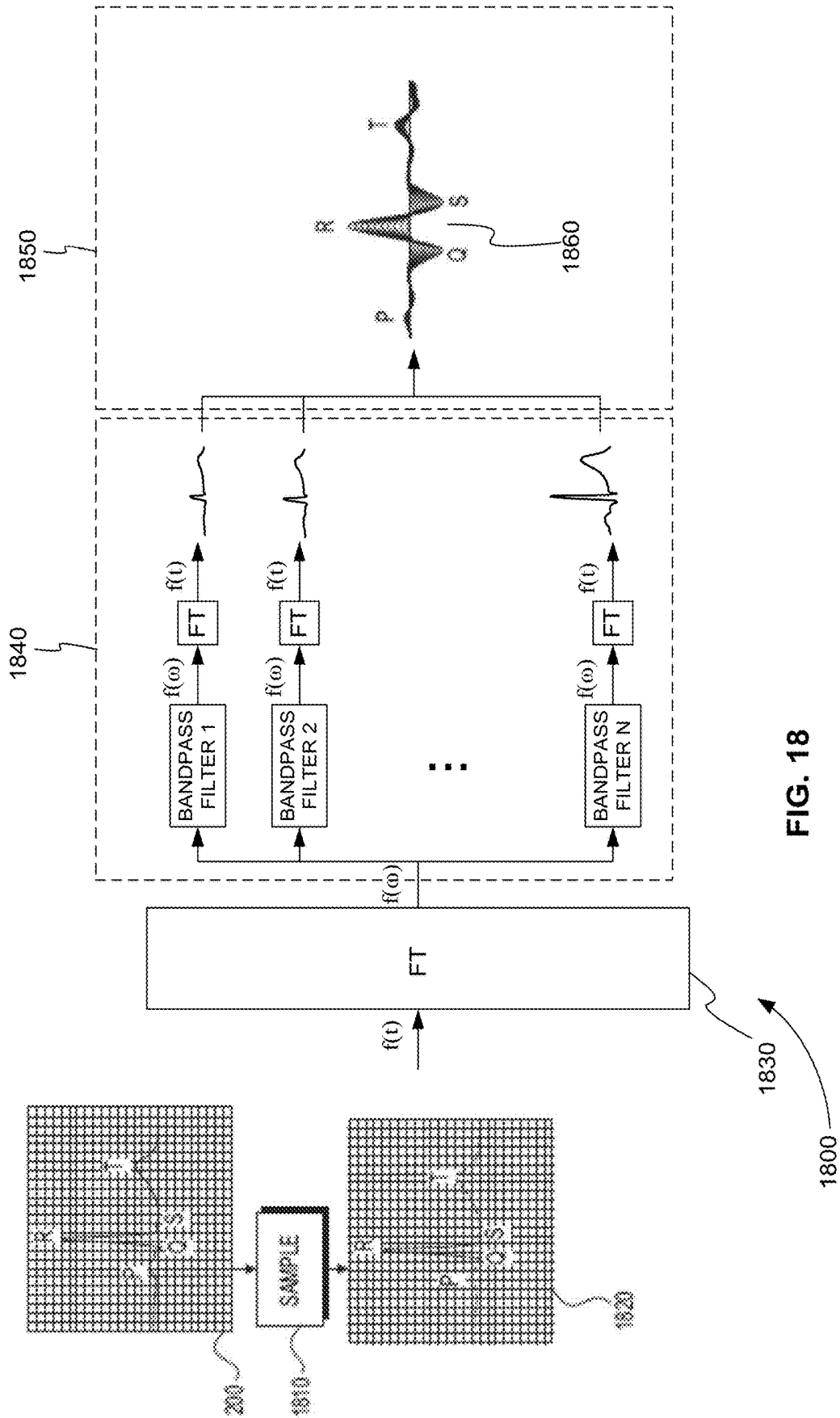

FIG. 18

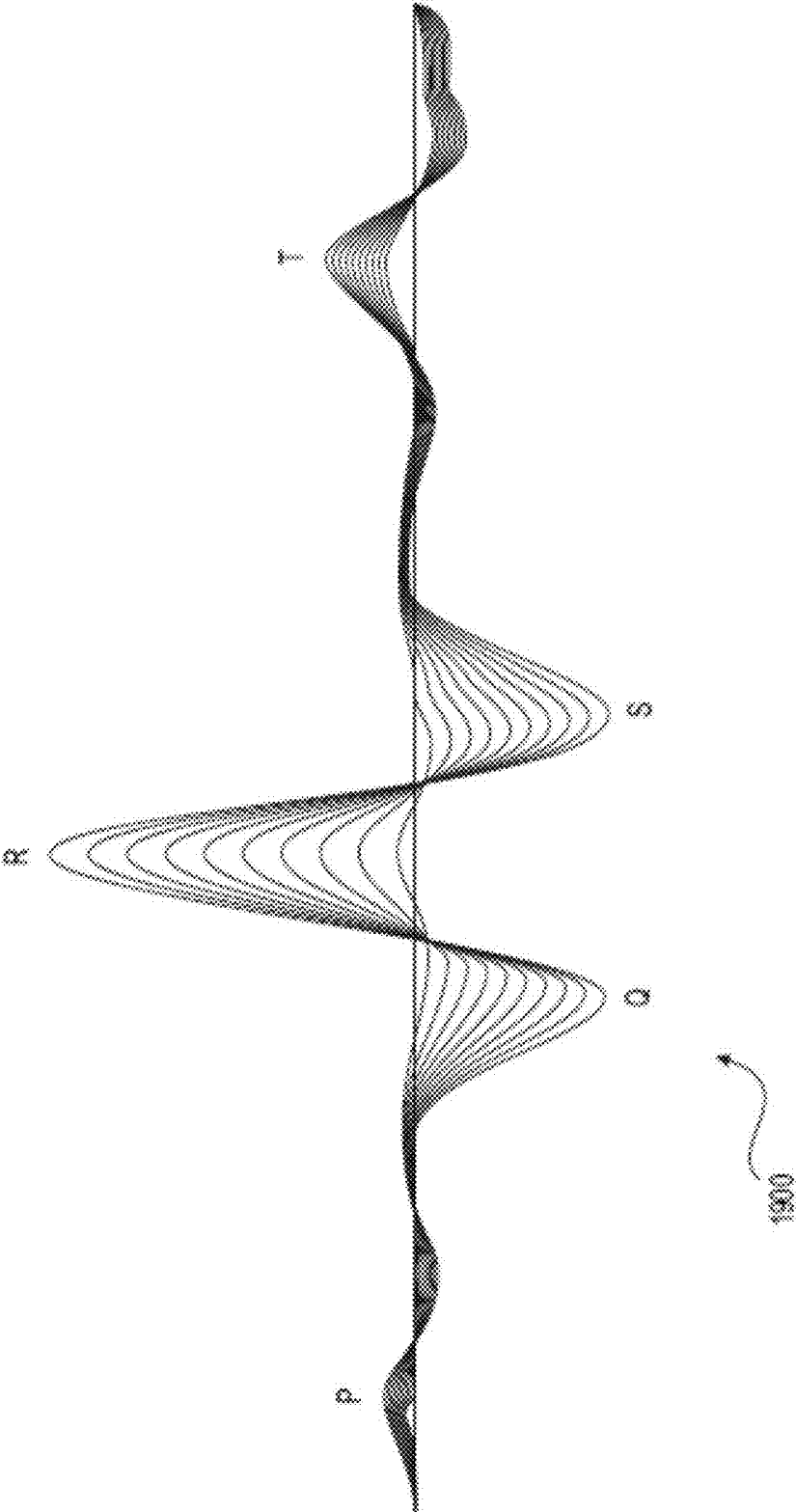
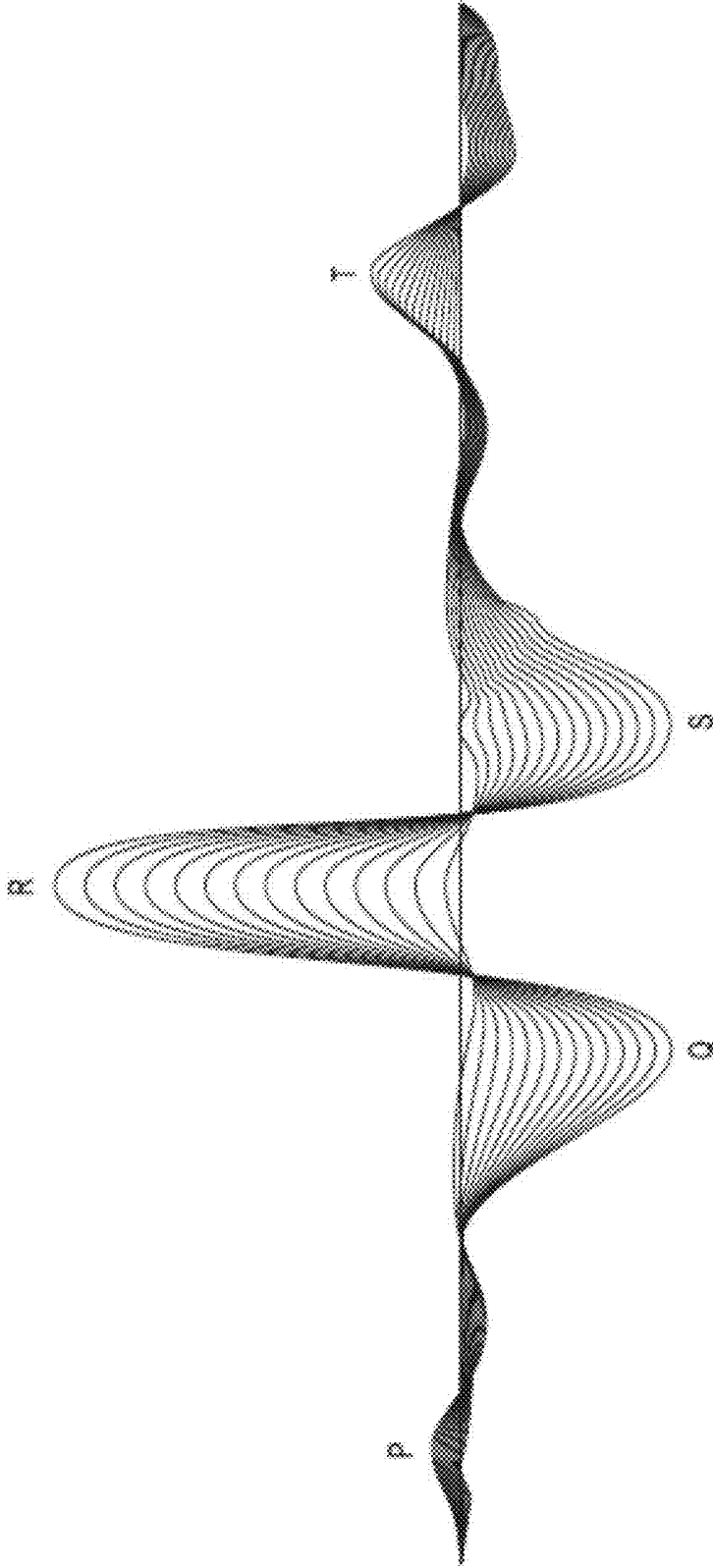
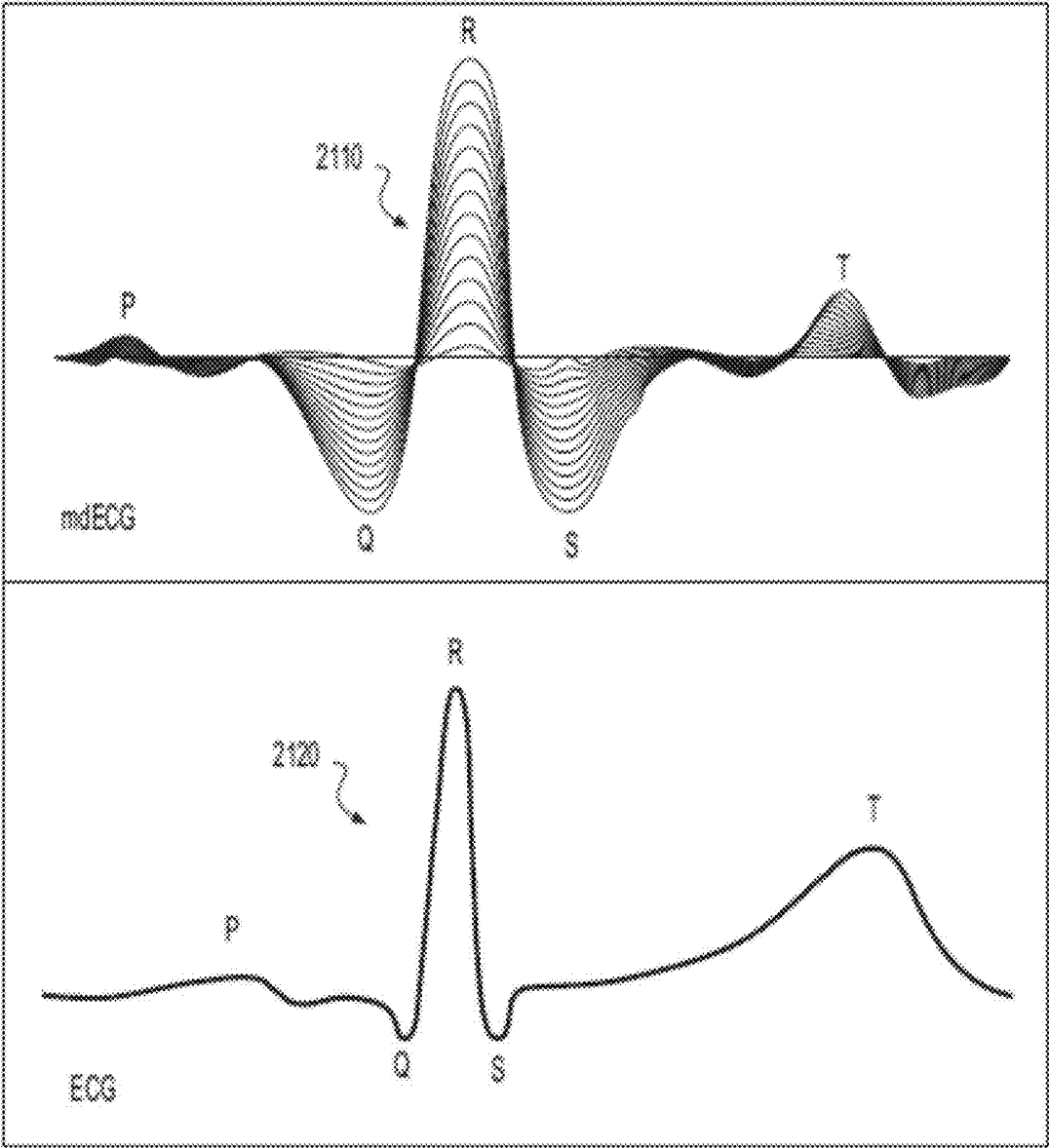

FIG. 19



2000

FIG. 20



2100 ↗

FIG. 21

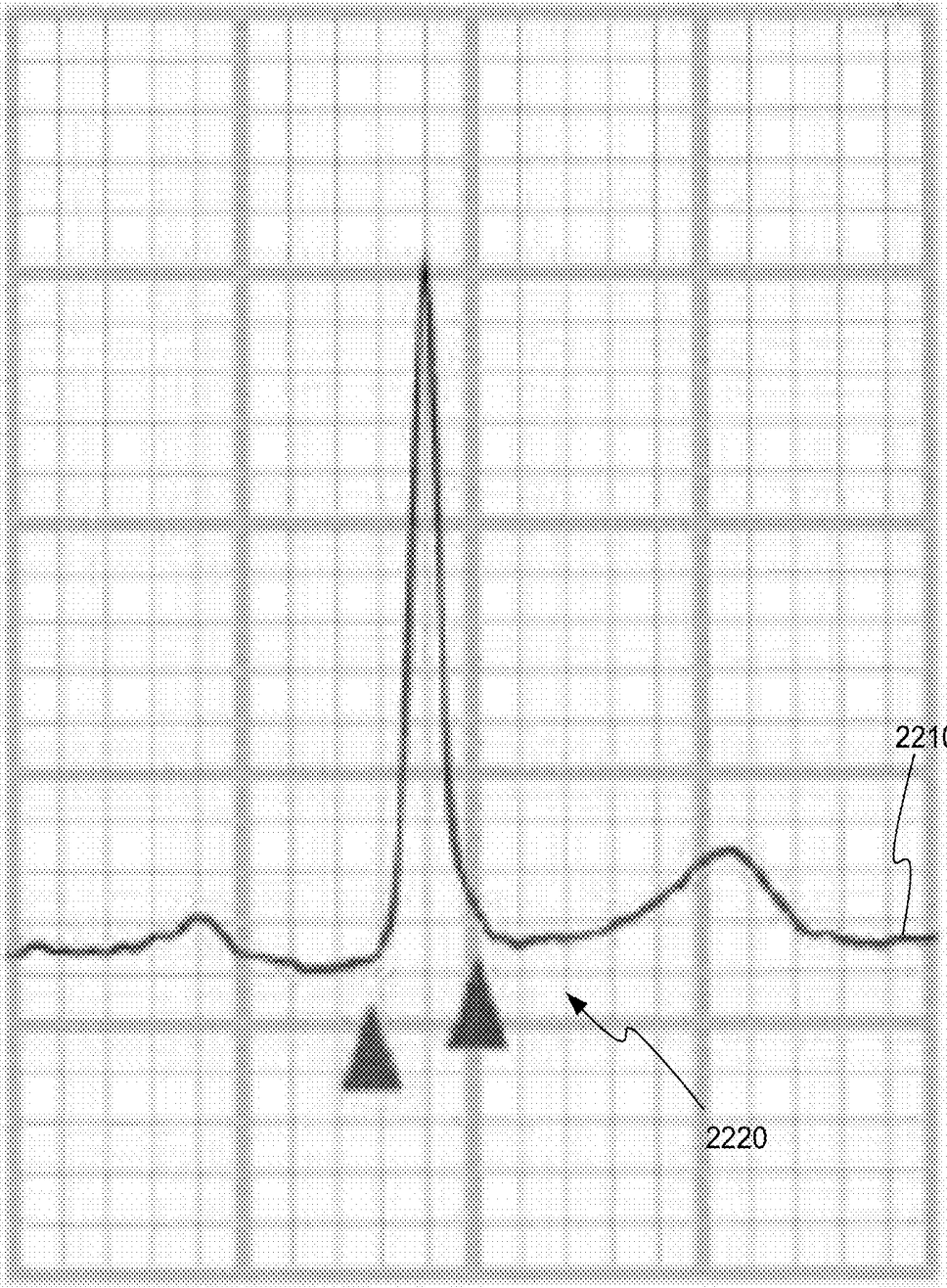

2200 →

FIG. 22

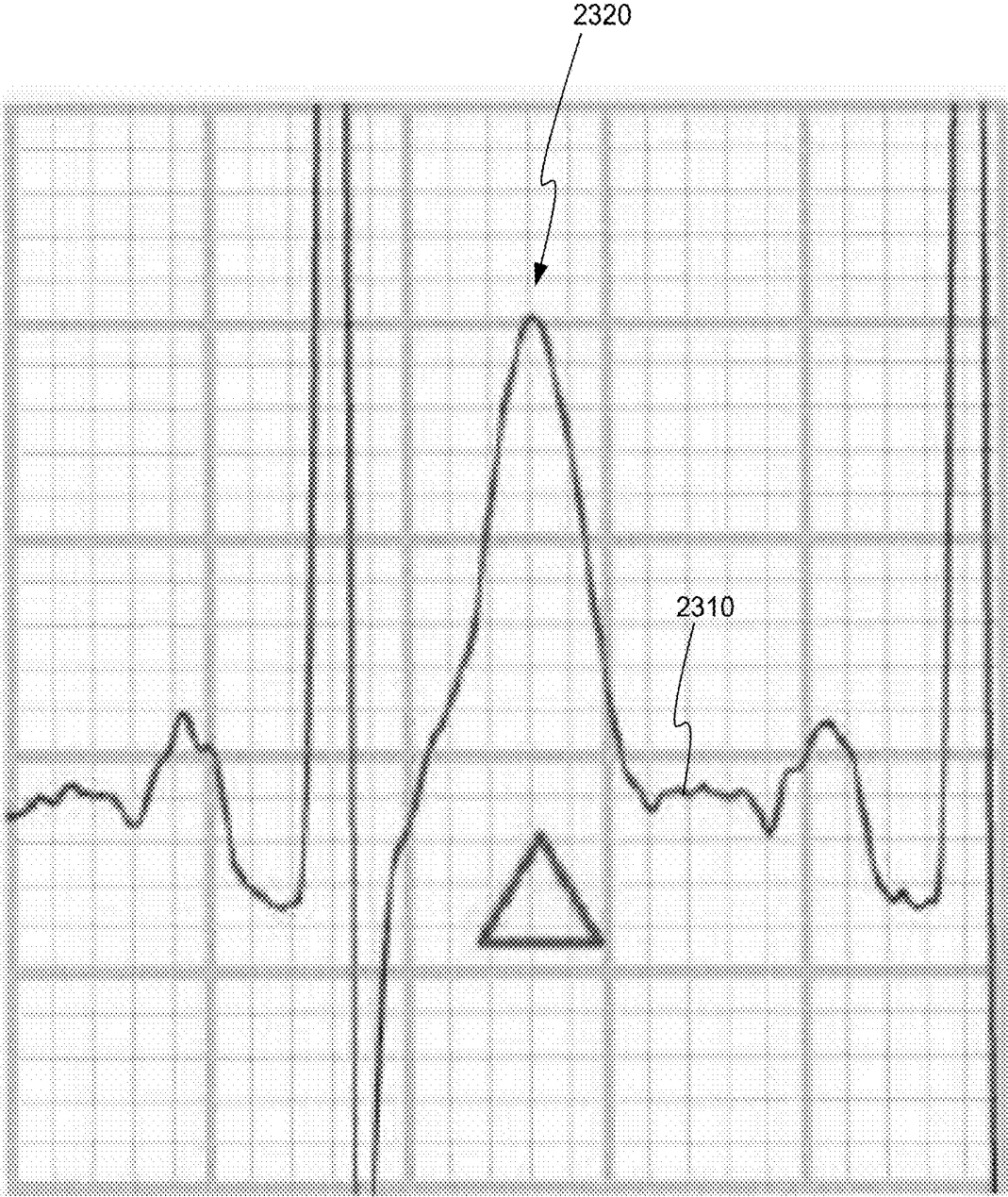

2300

FIG. 23

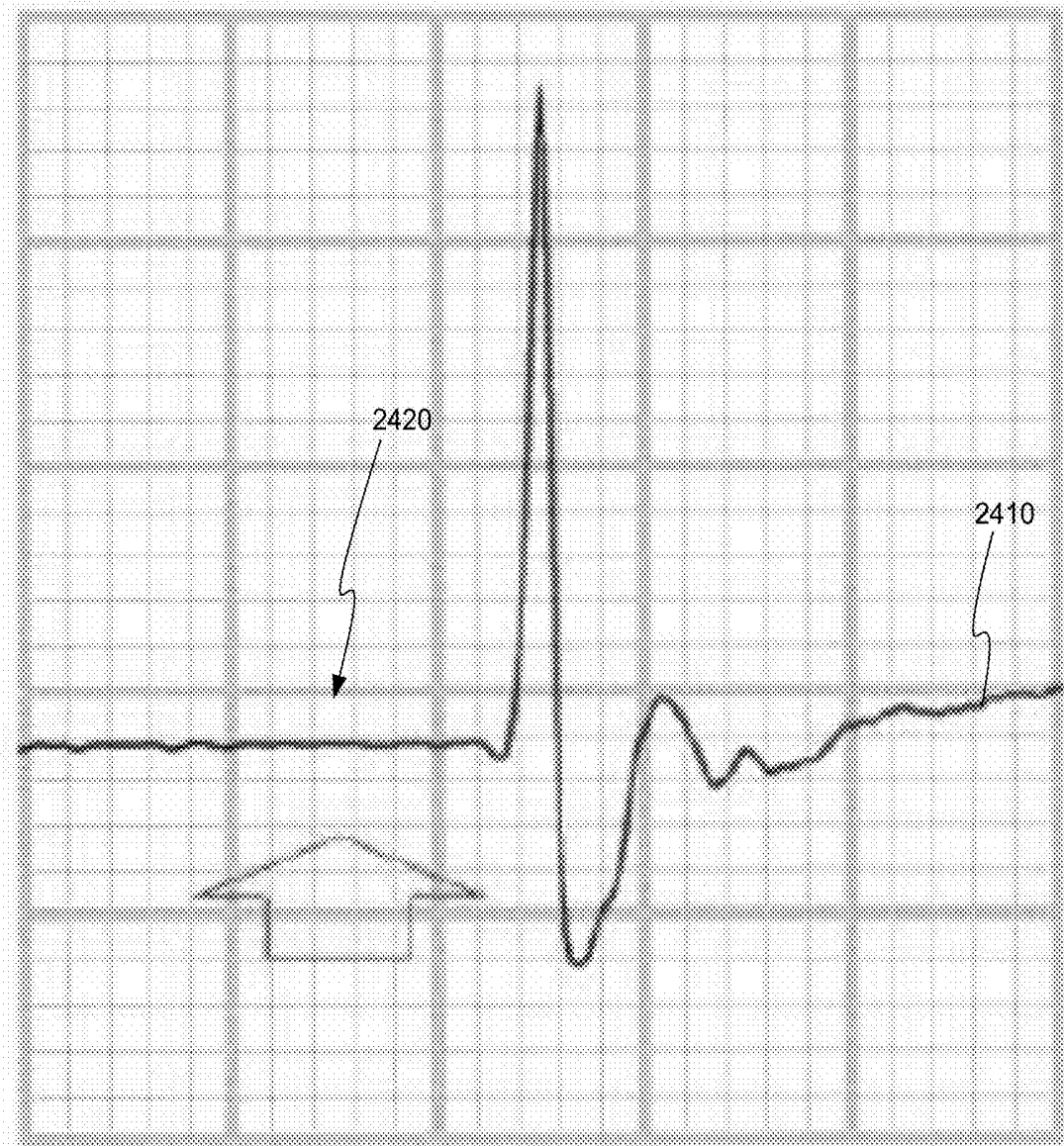

2400 →

FIG. 24

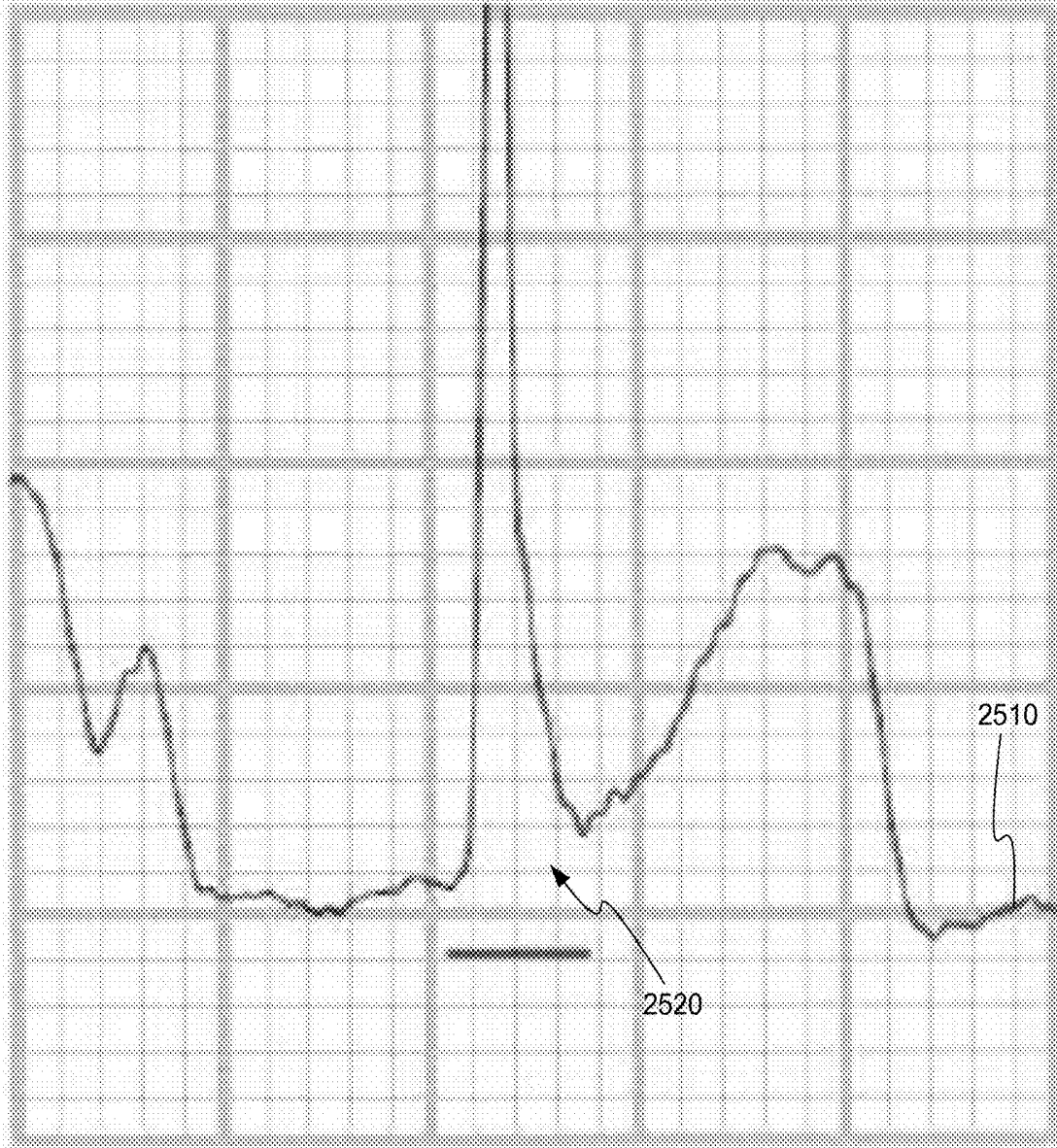

2500 →

FIG. 25

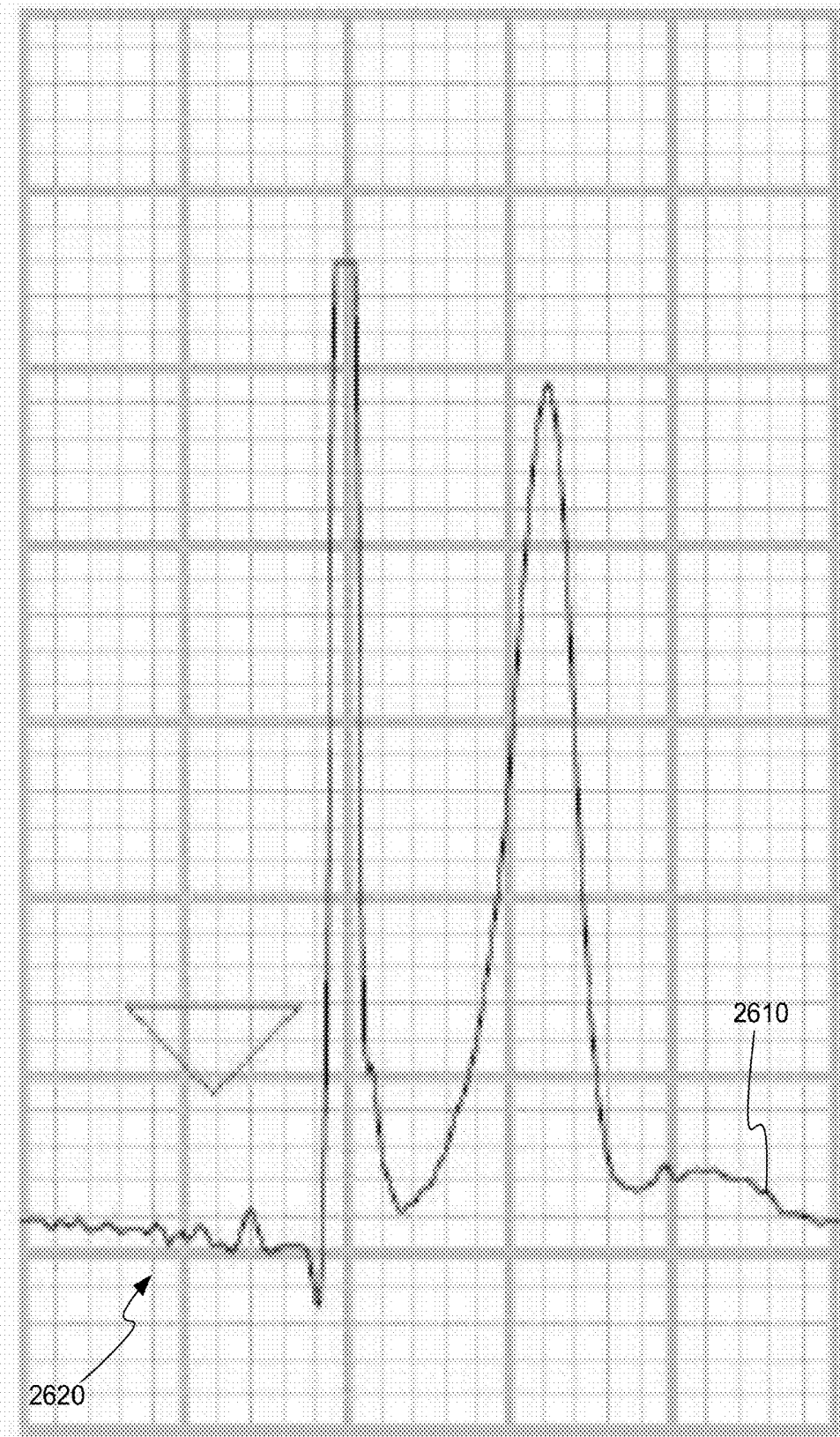

2600

FIG. 26

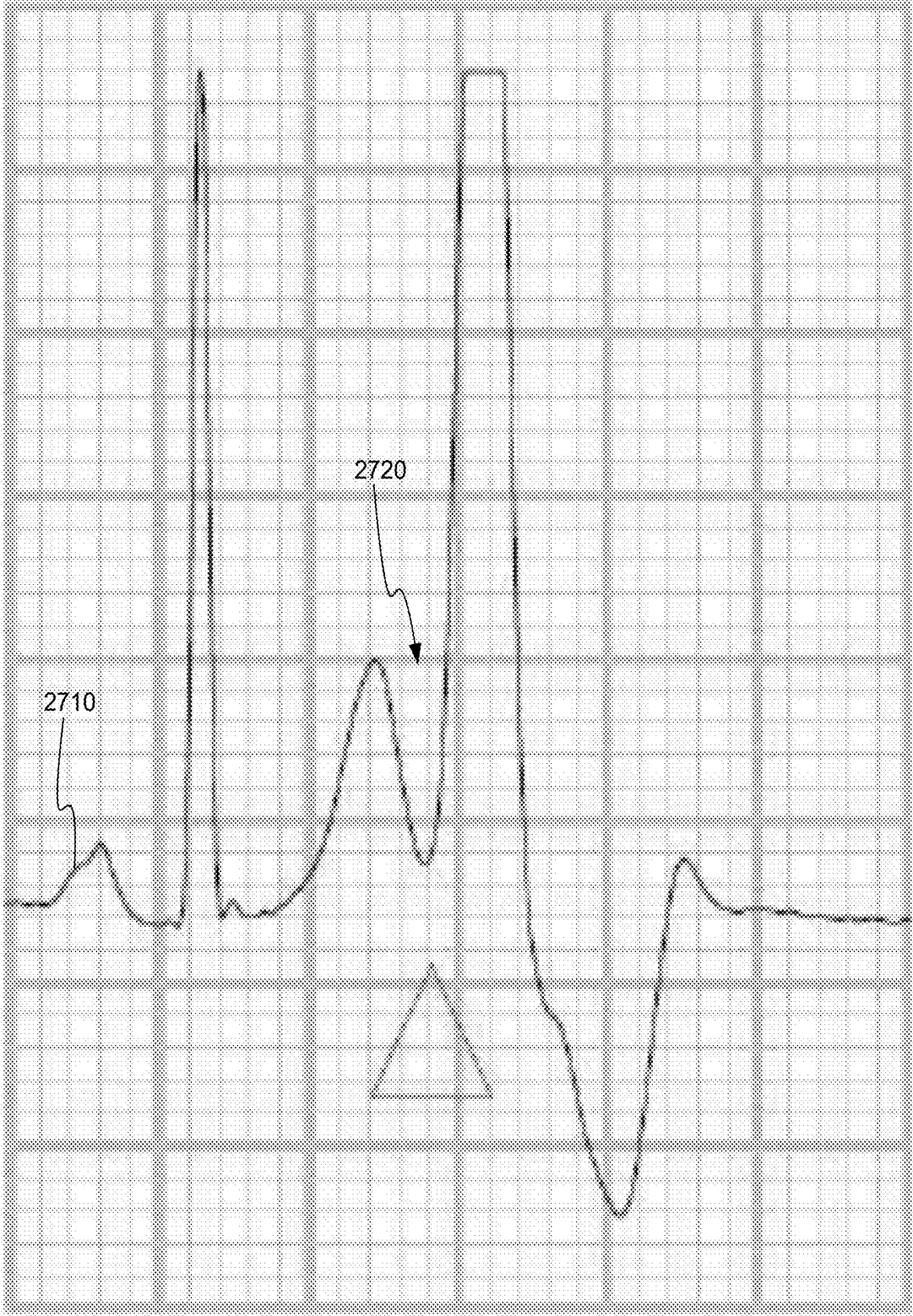

2700 → **FIG. 27**



2800

FIG. 28

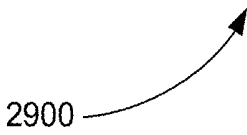
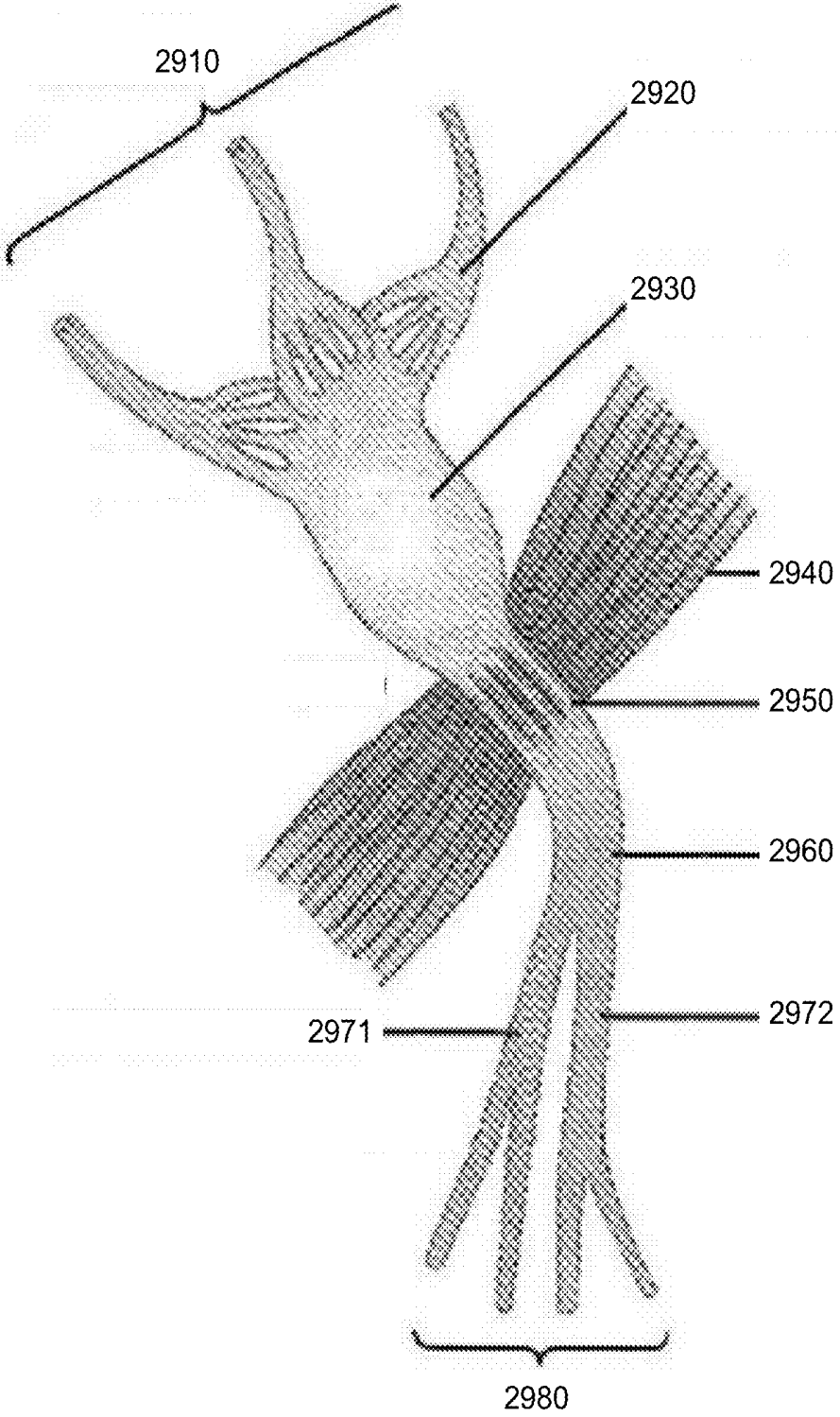

FIG. 29

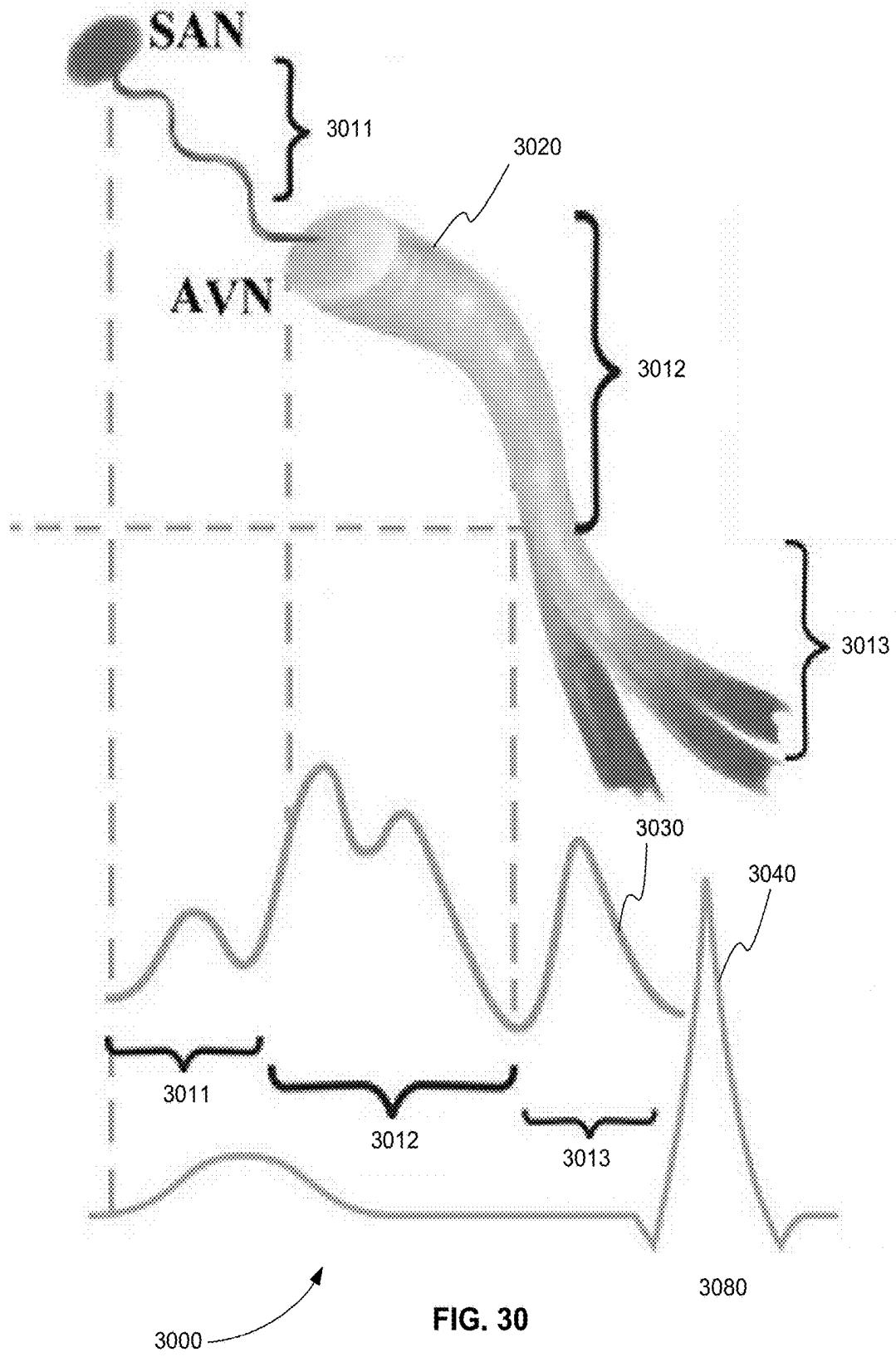

FIG. 30

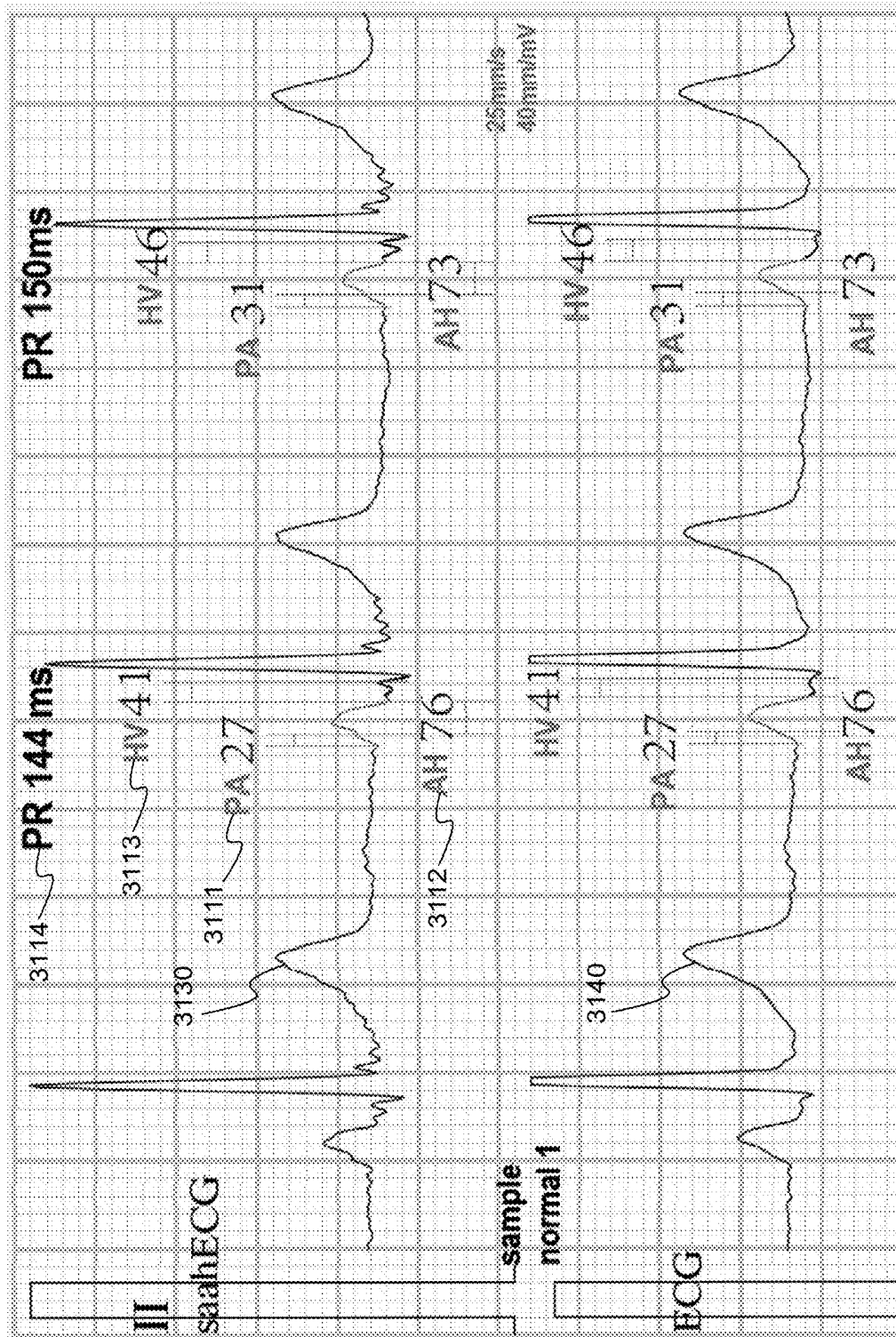
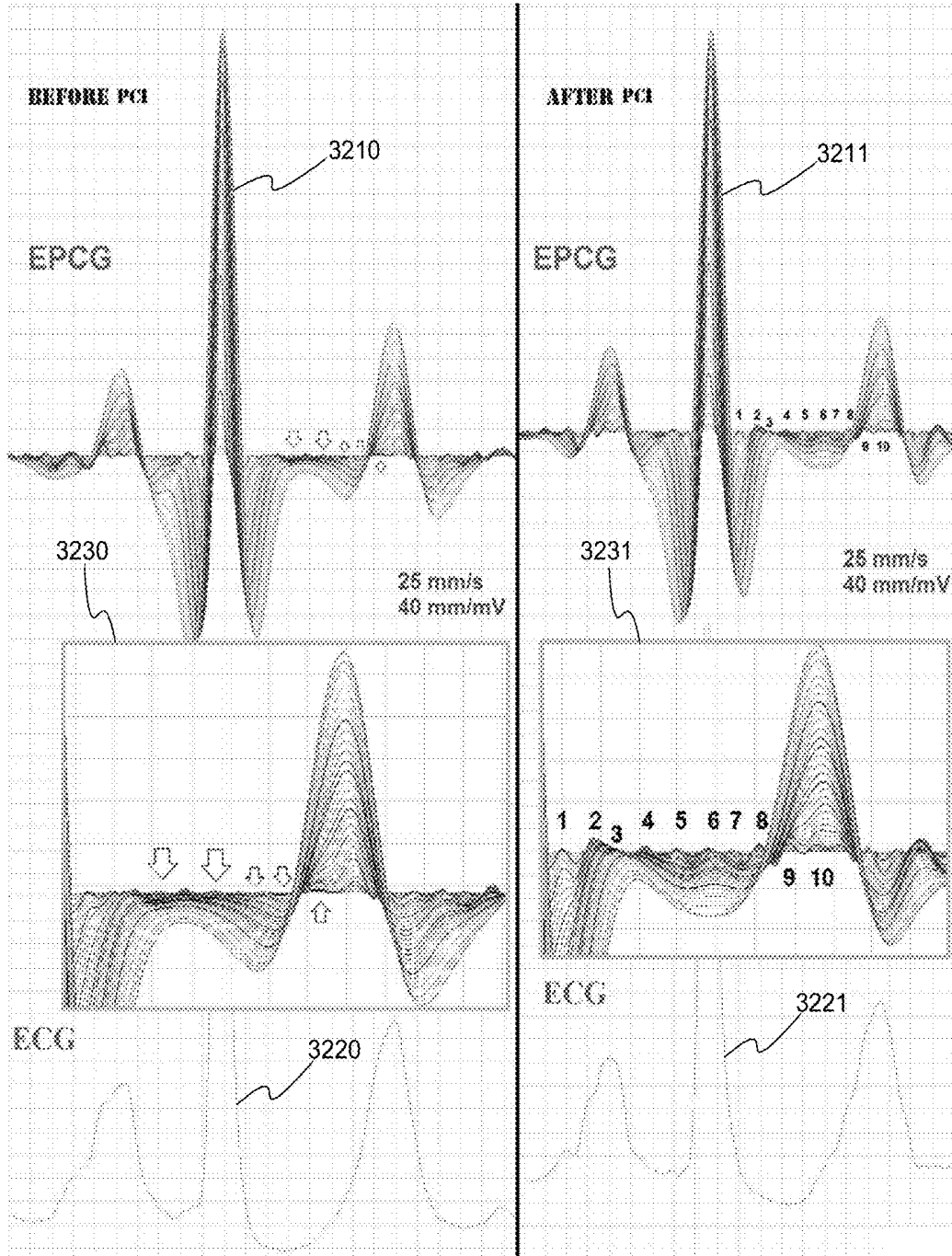

FIG. 31

3100



3200

FIG. 32

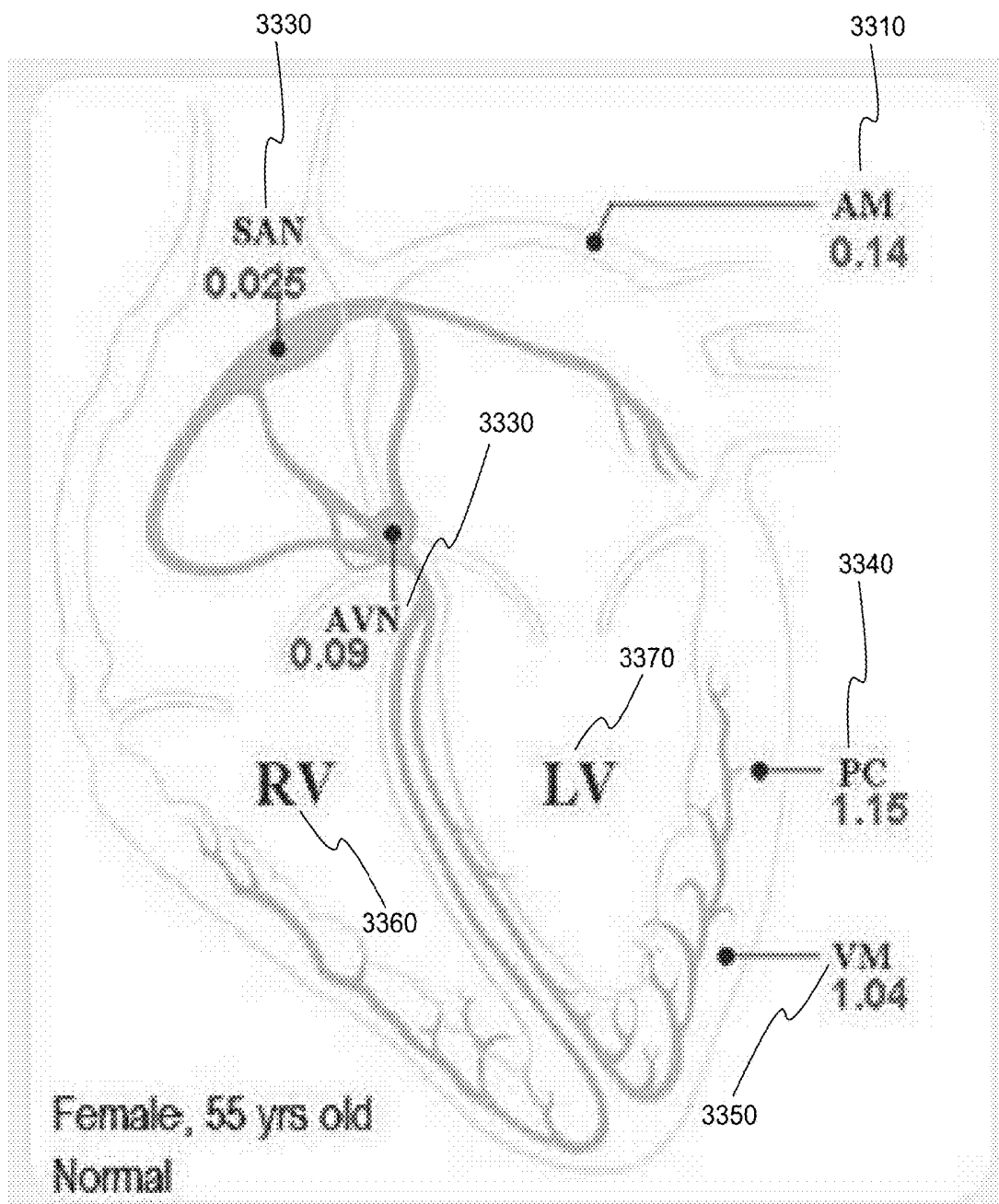

3300

FIG. 33

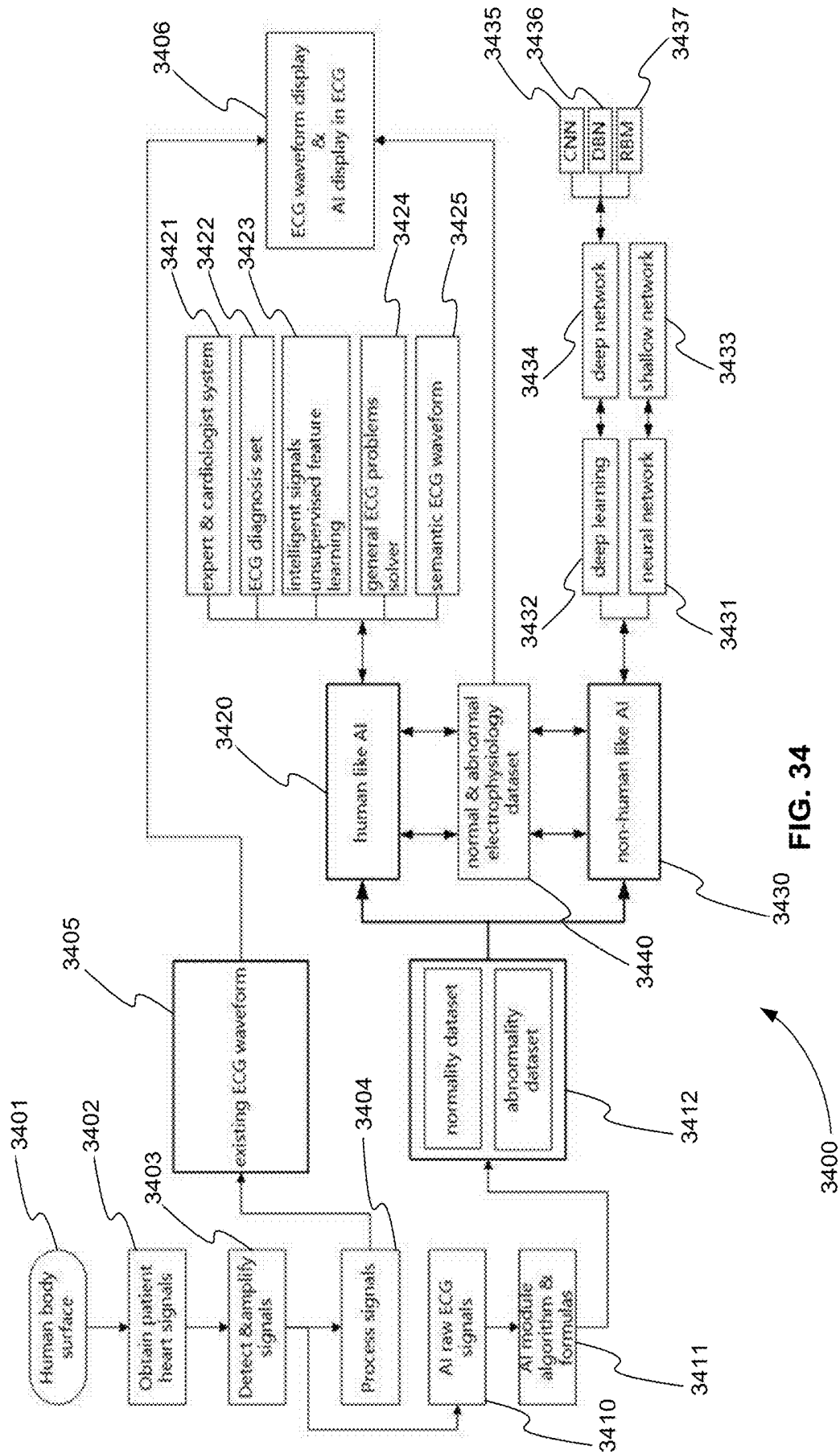

FIG. 34

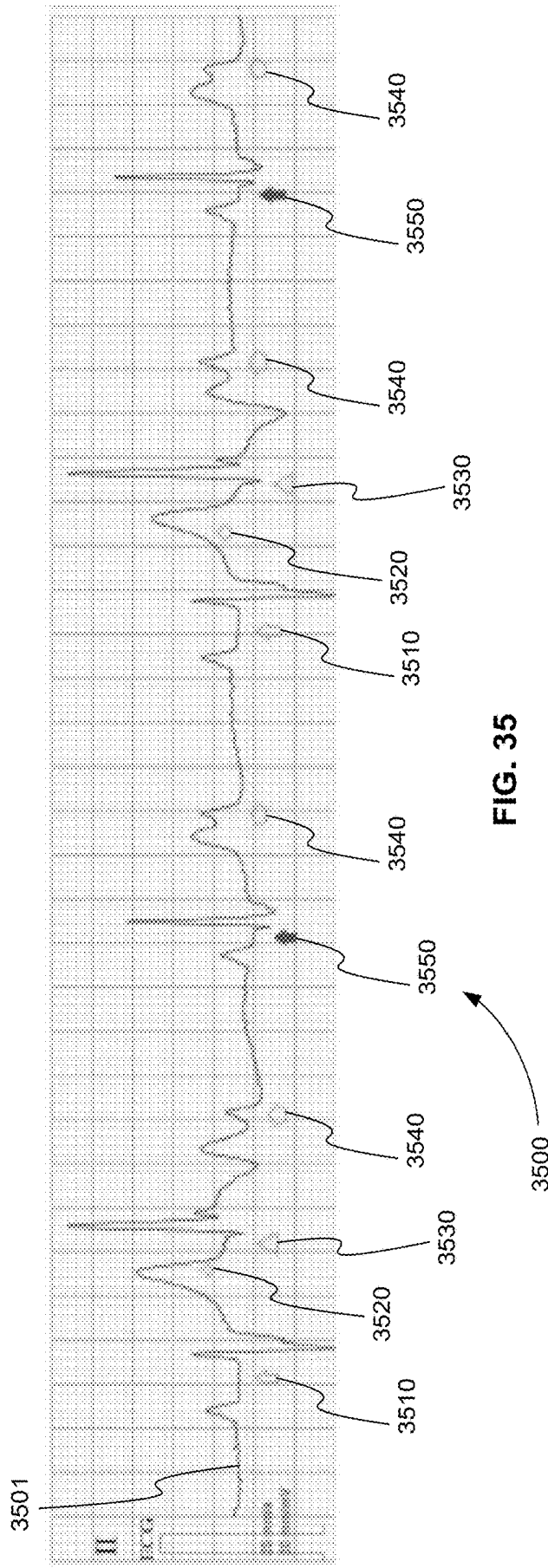

FIG. 35

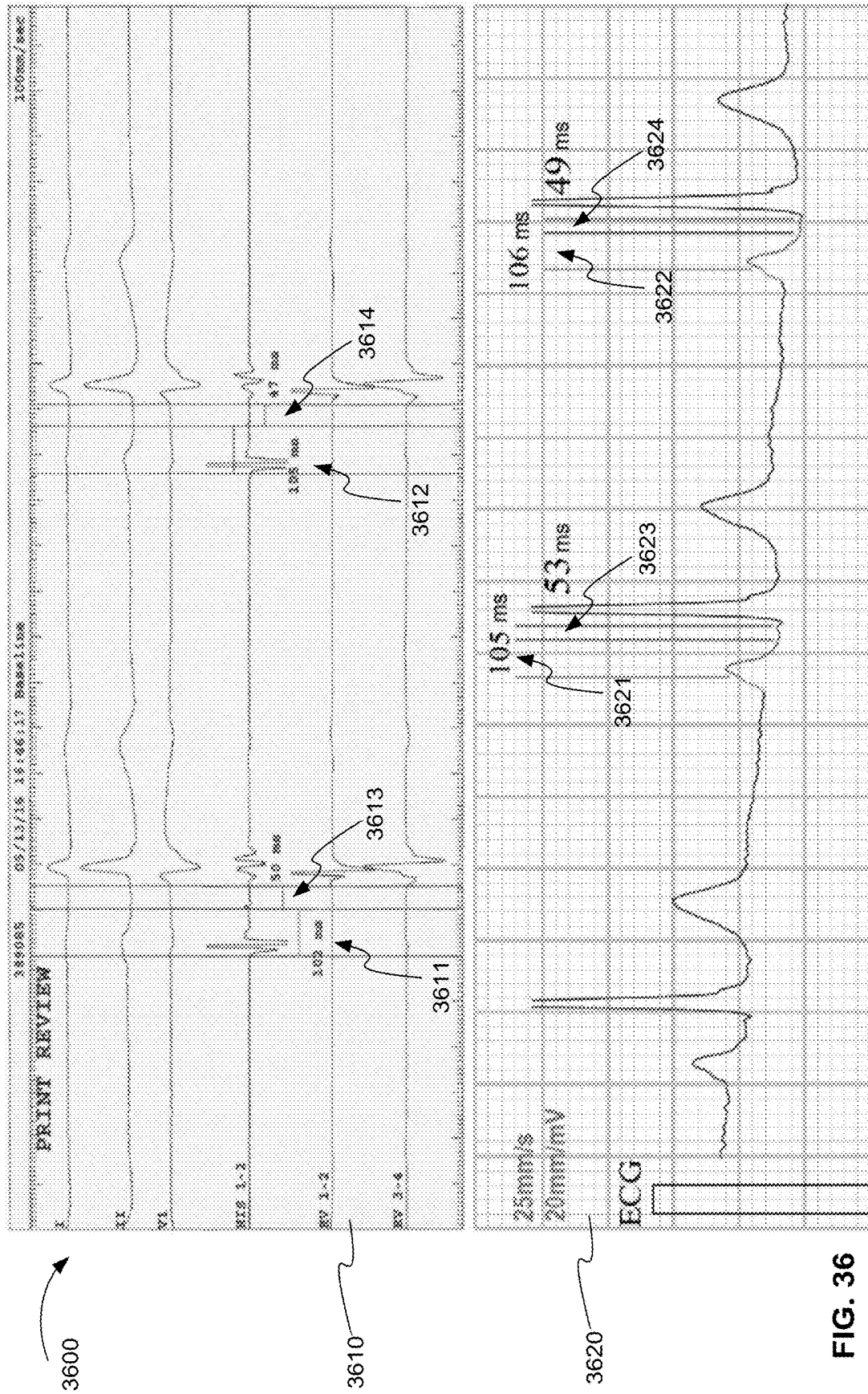

FIG. 36

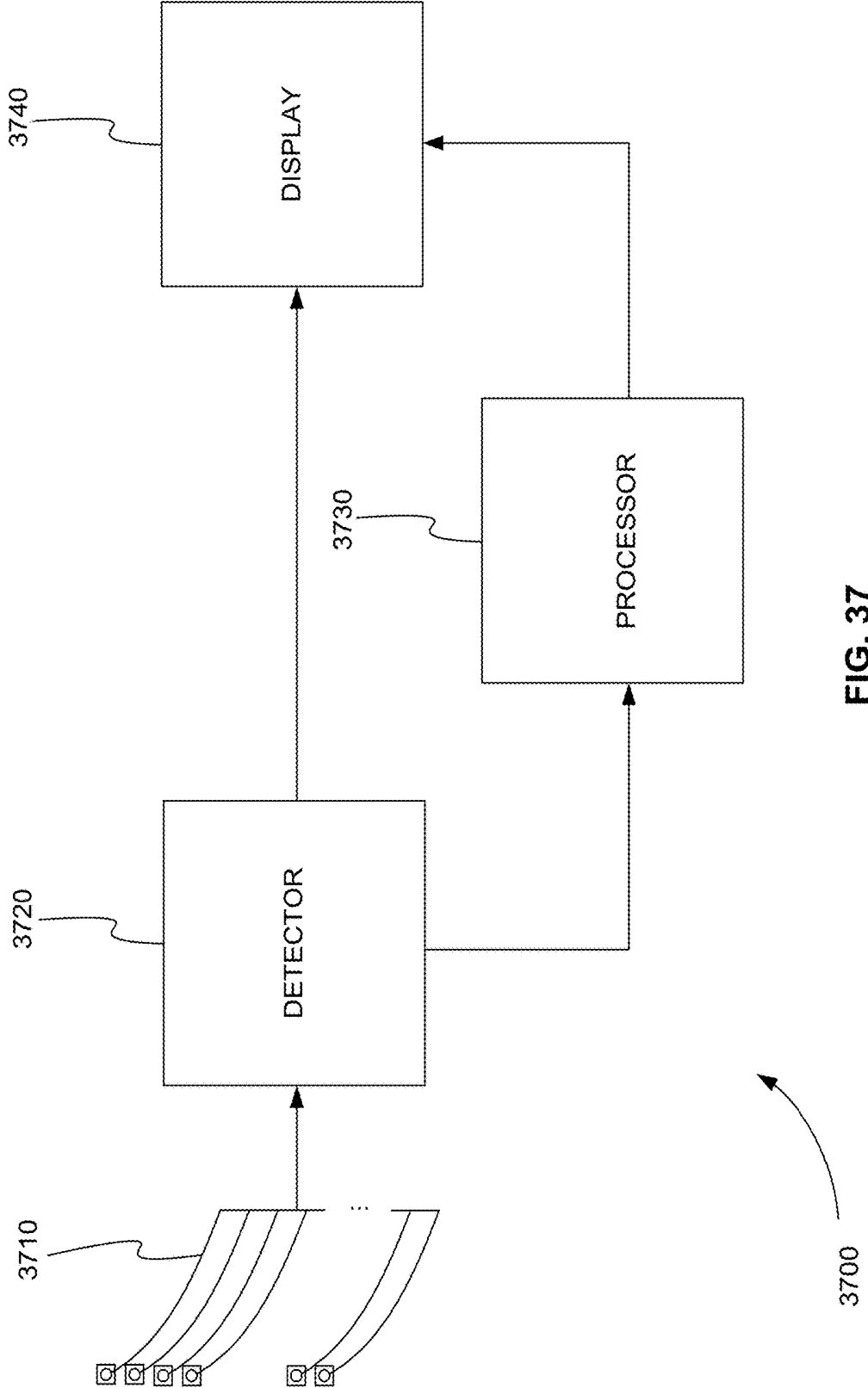
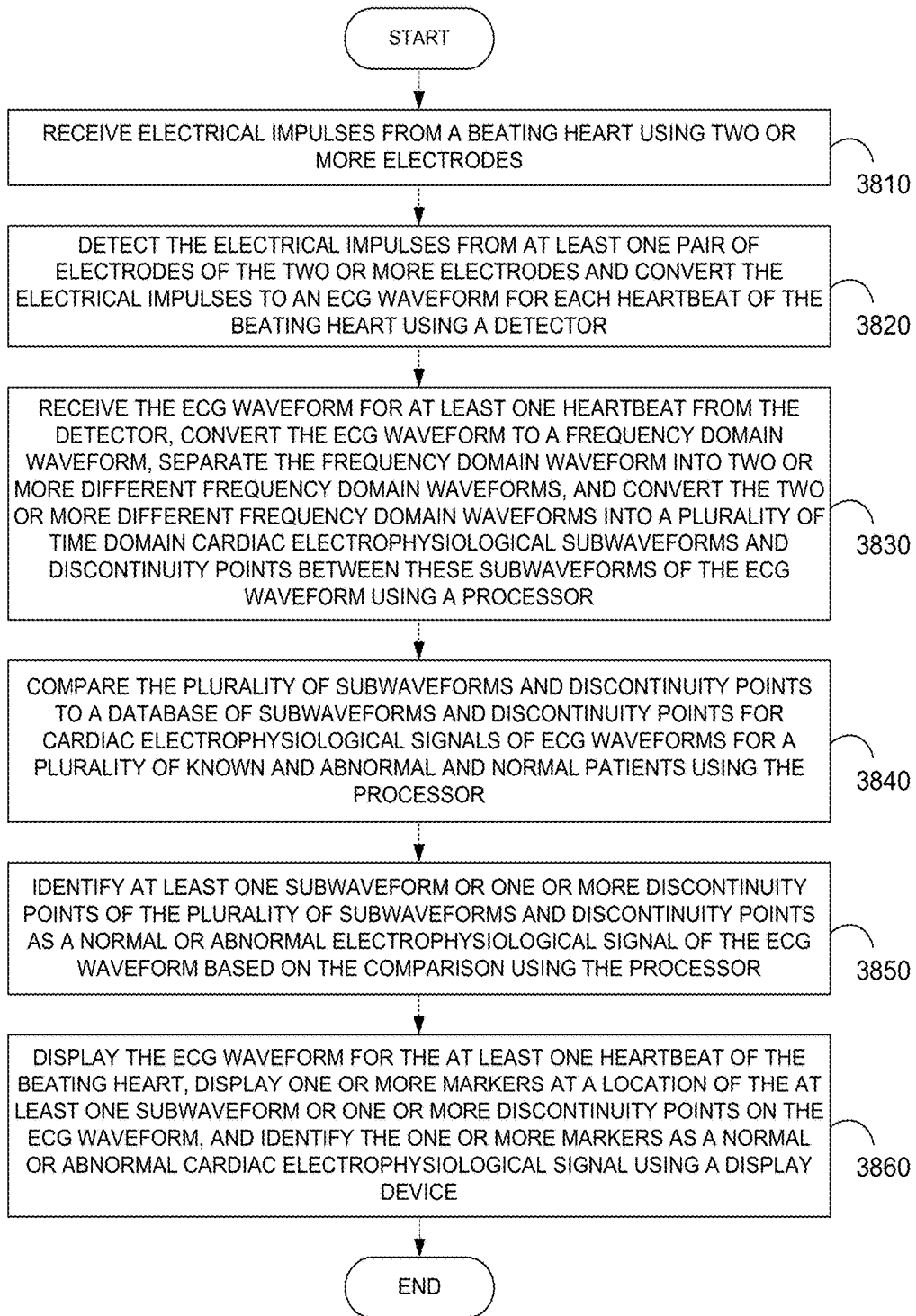

FIG. 37



3800 ↗

FIG. 38

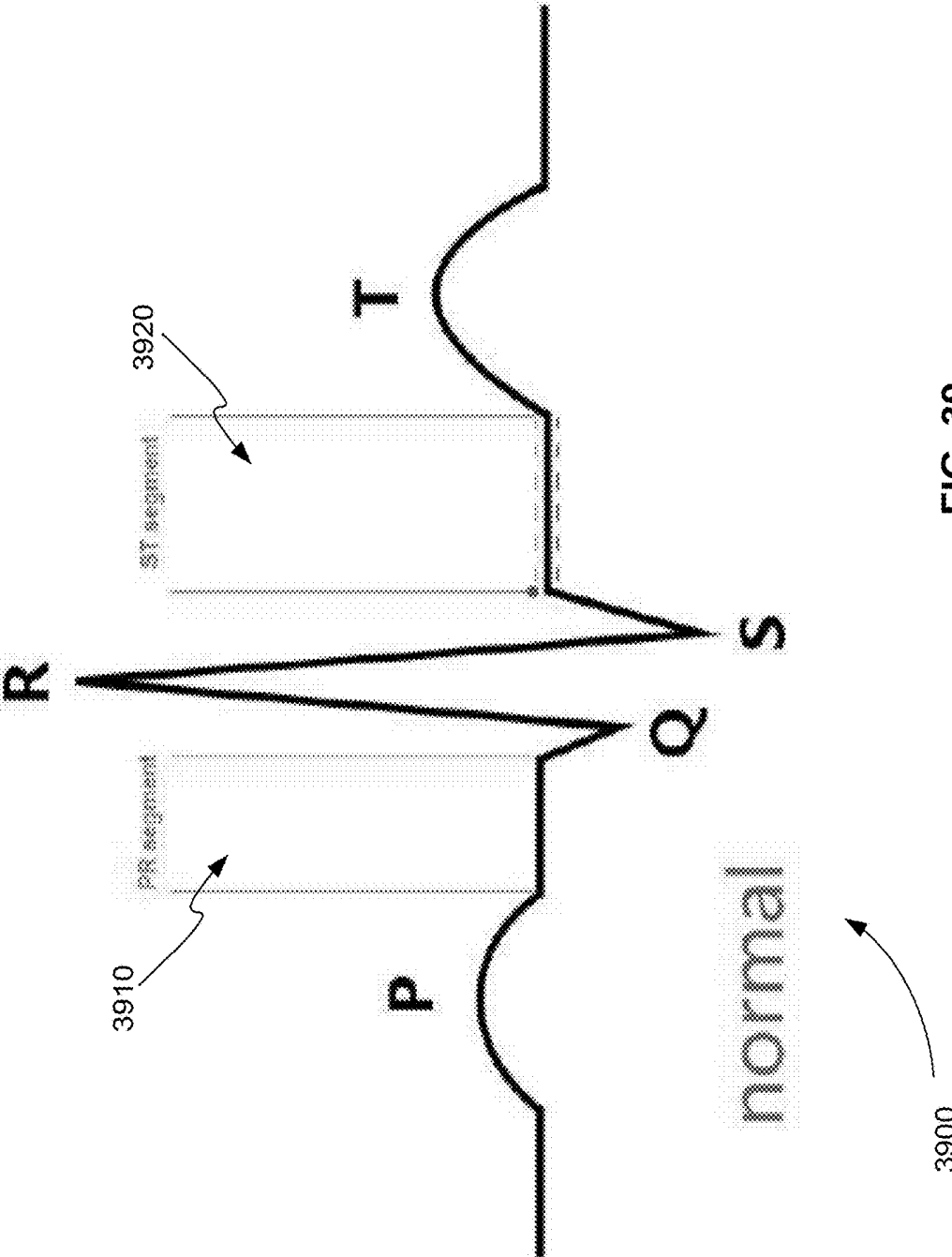

FIG. 39

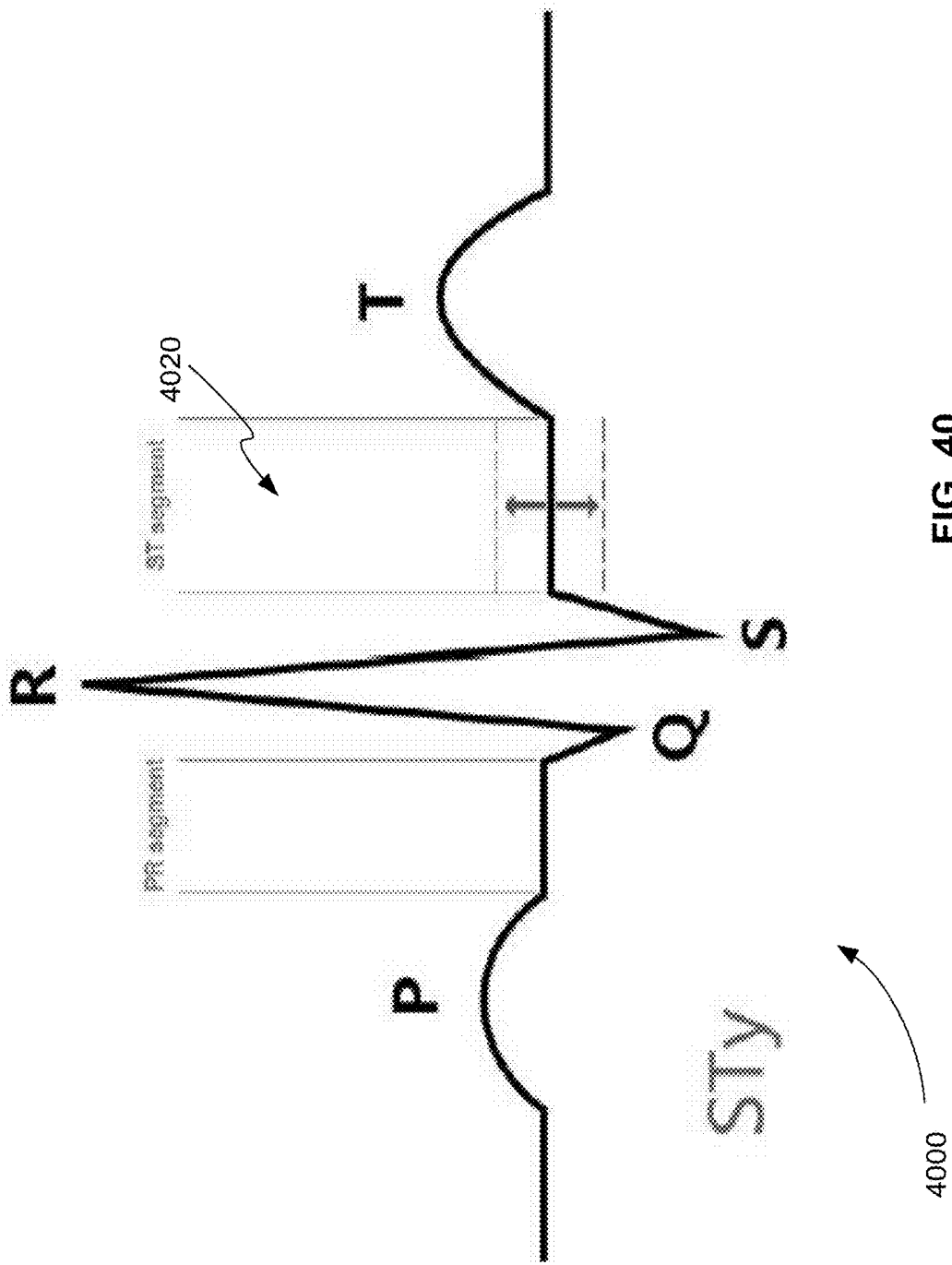

FIG. 40

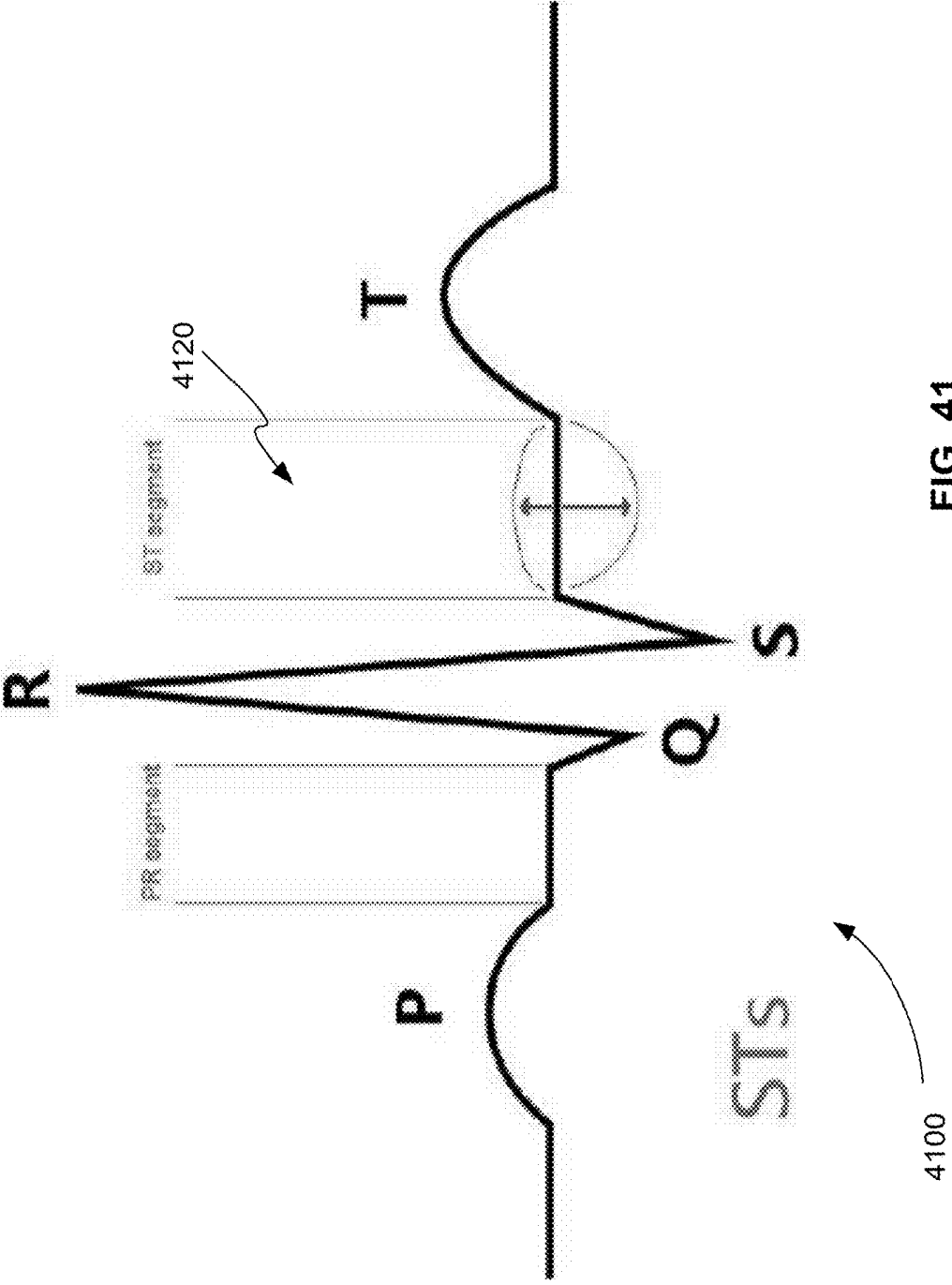

FIG. 41

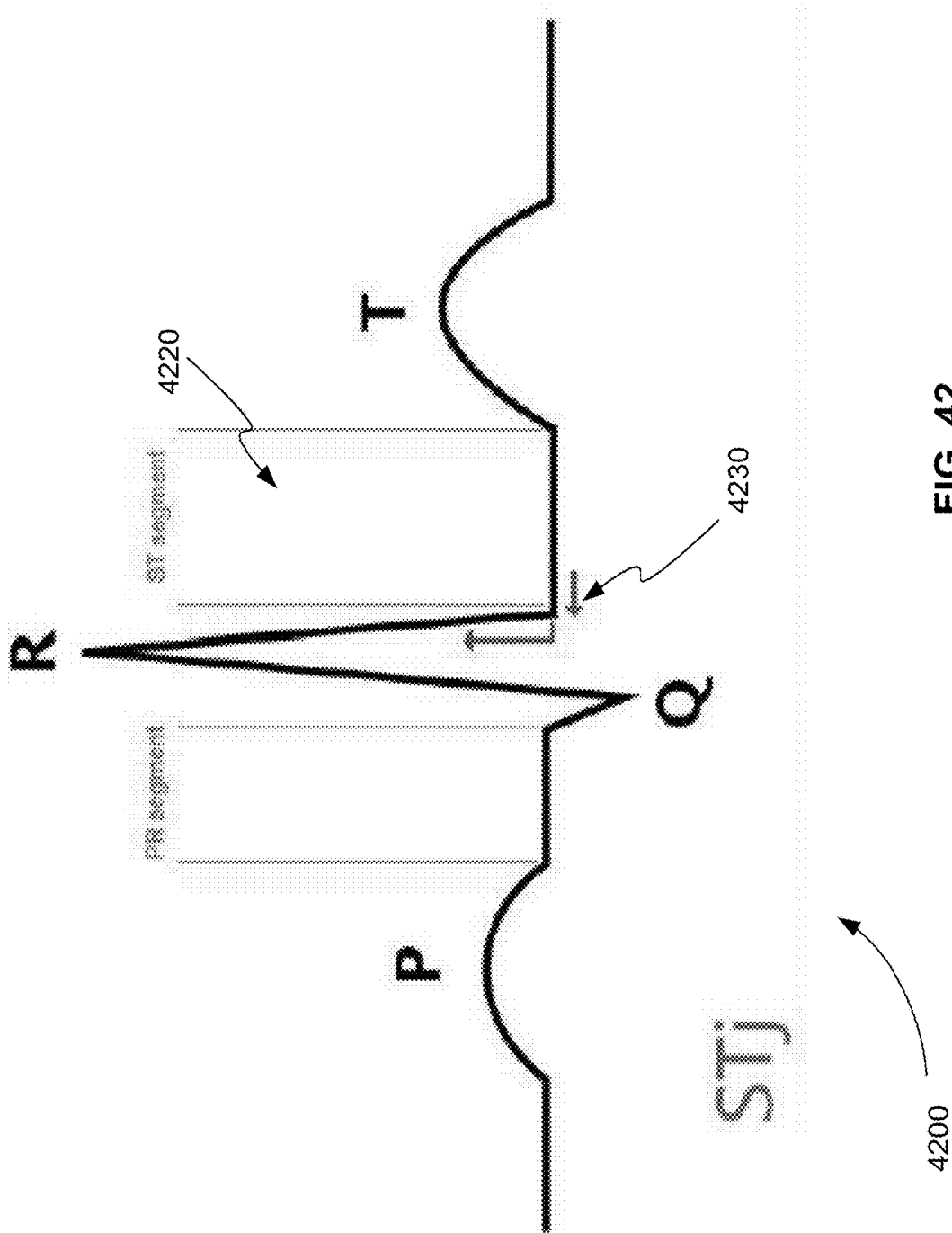

FIG. 42

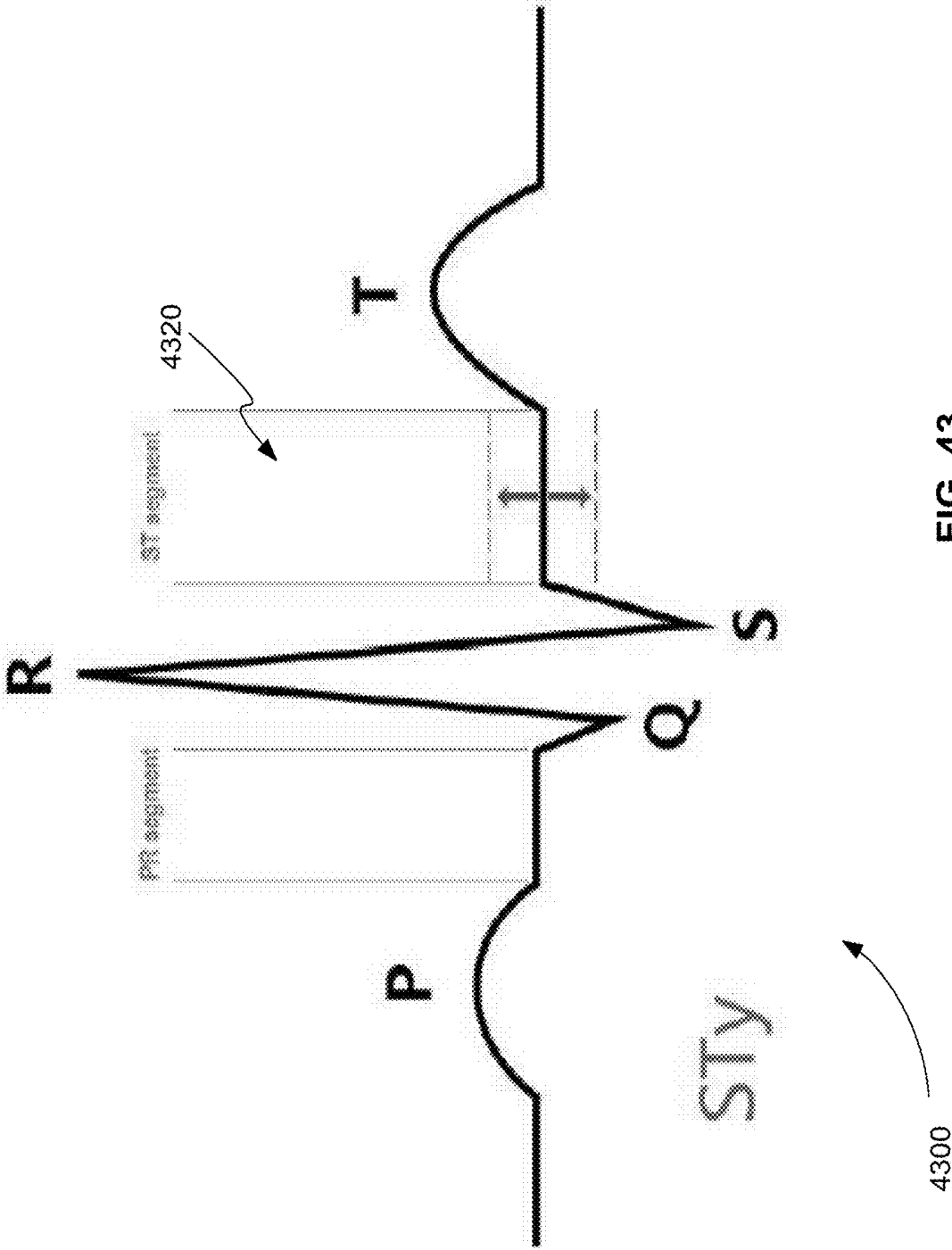

FIG. 43

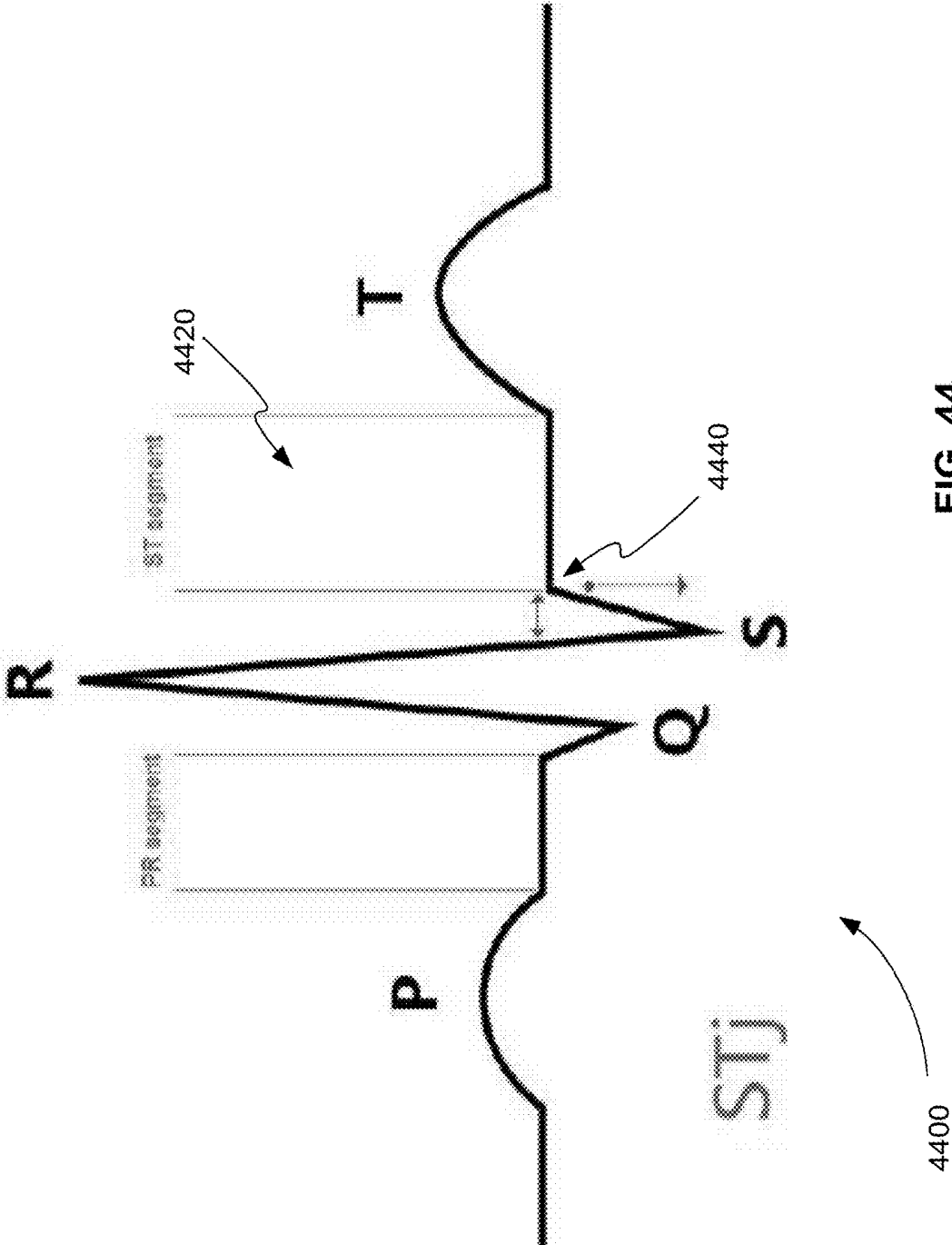
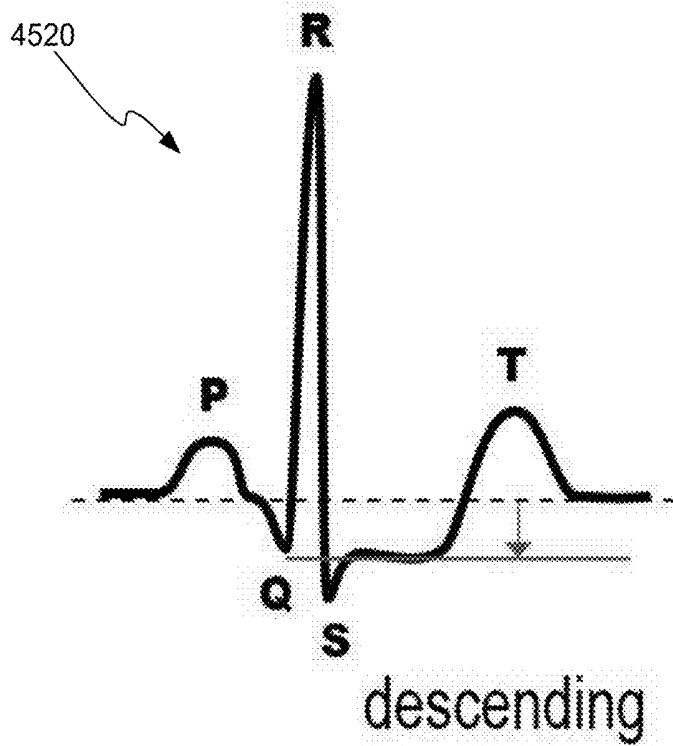
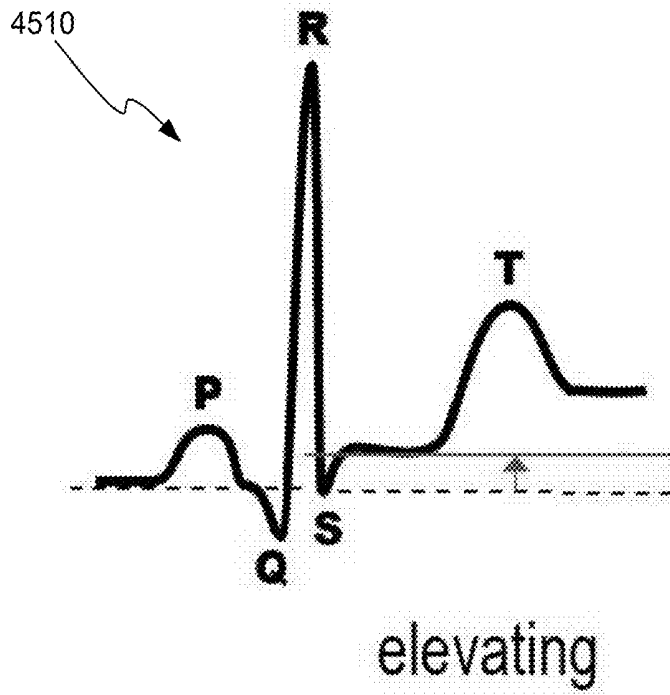
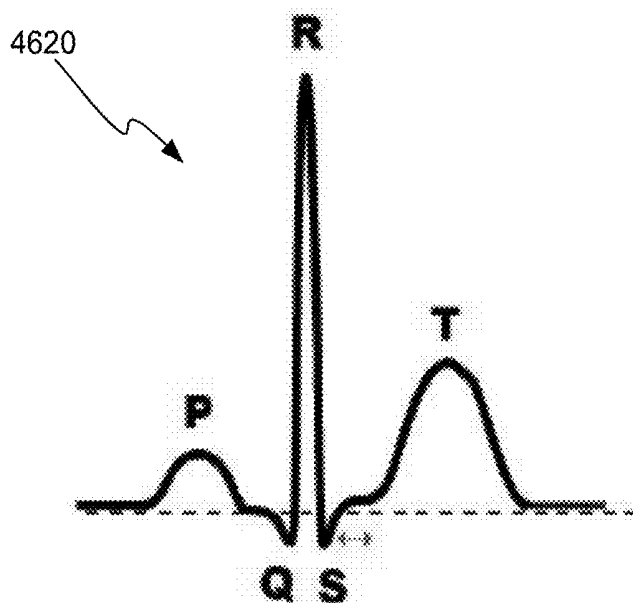
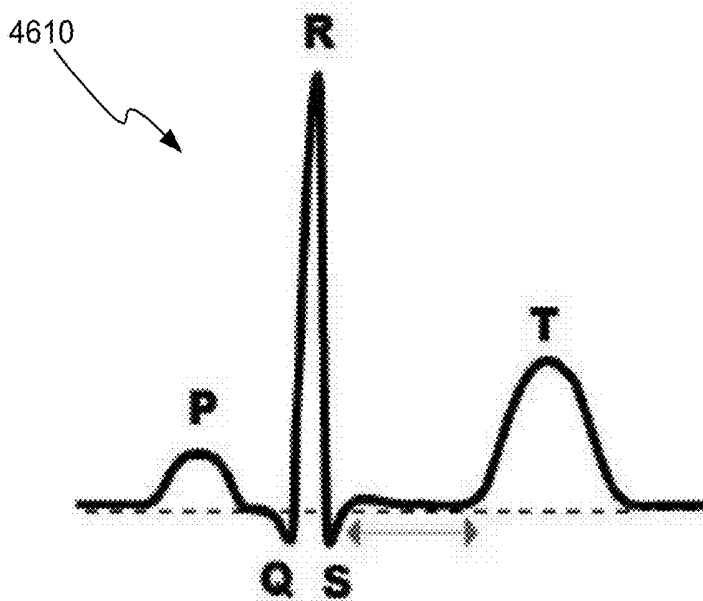

FIG. 44



4500

FIG. 45



4600

FIG. 46

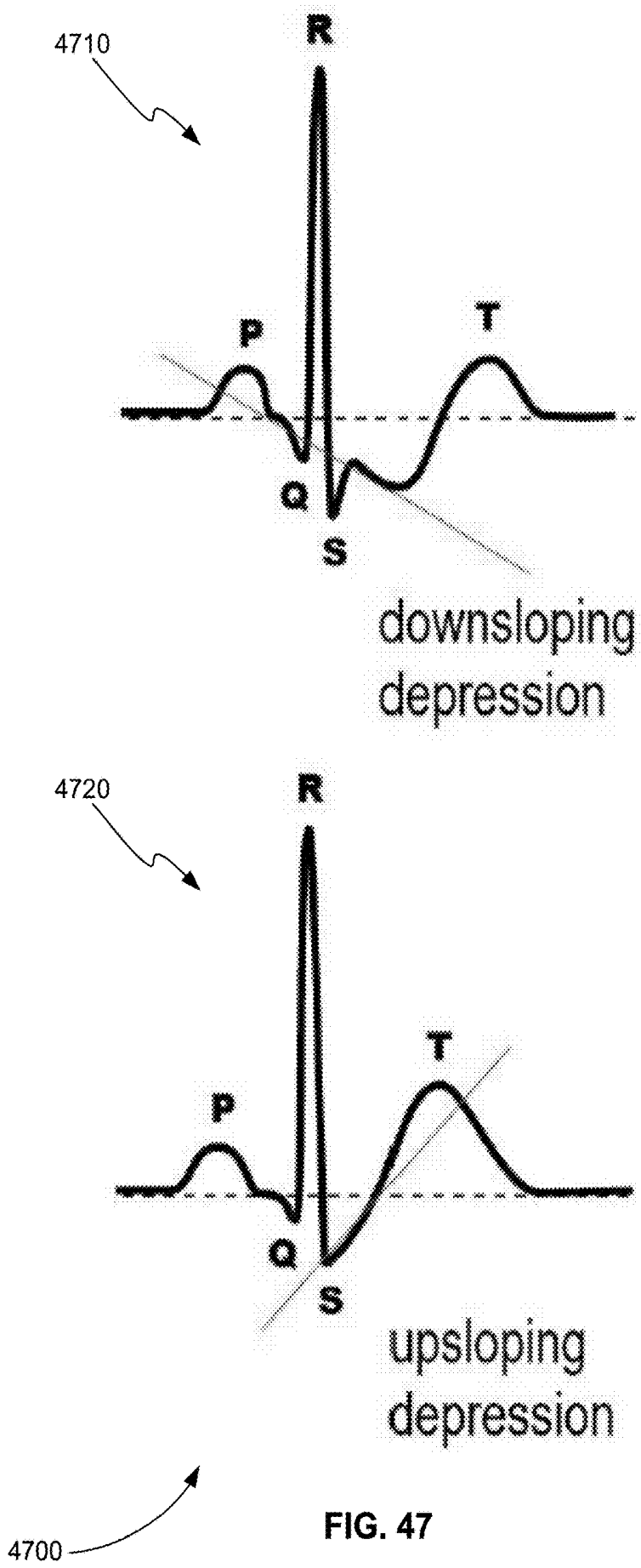

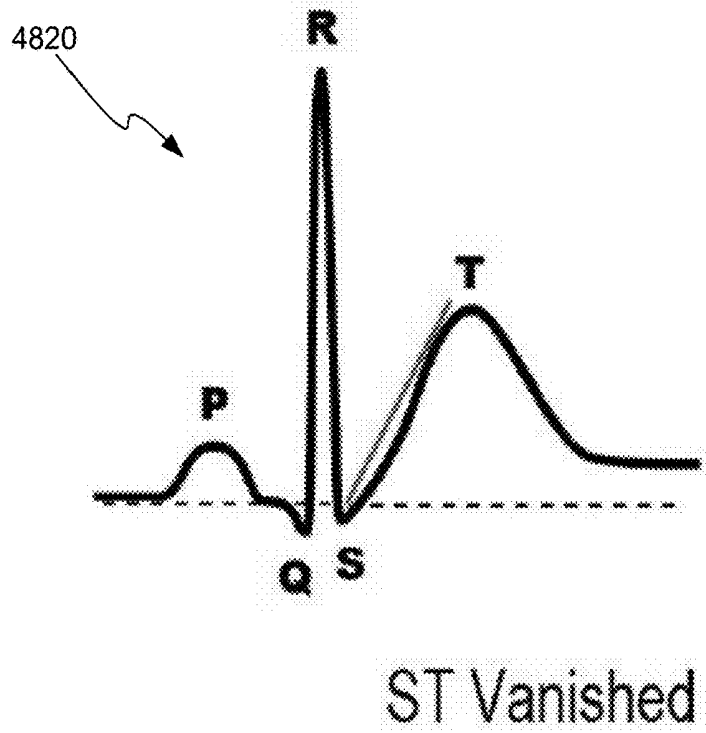
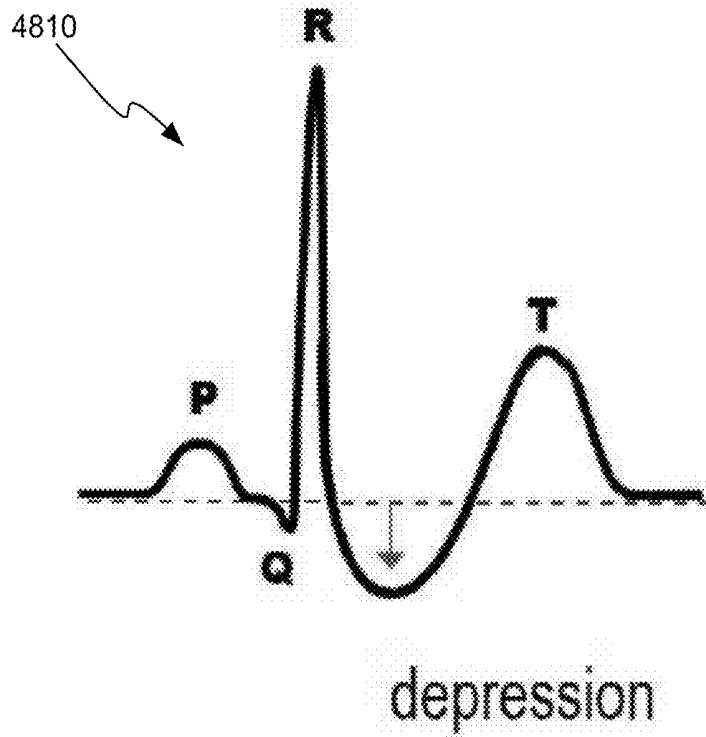

4800

FIG. 48

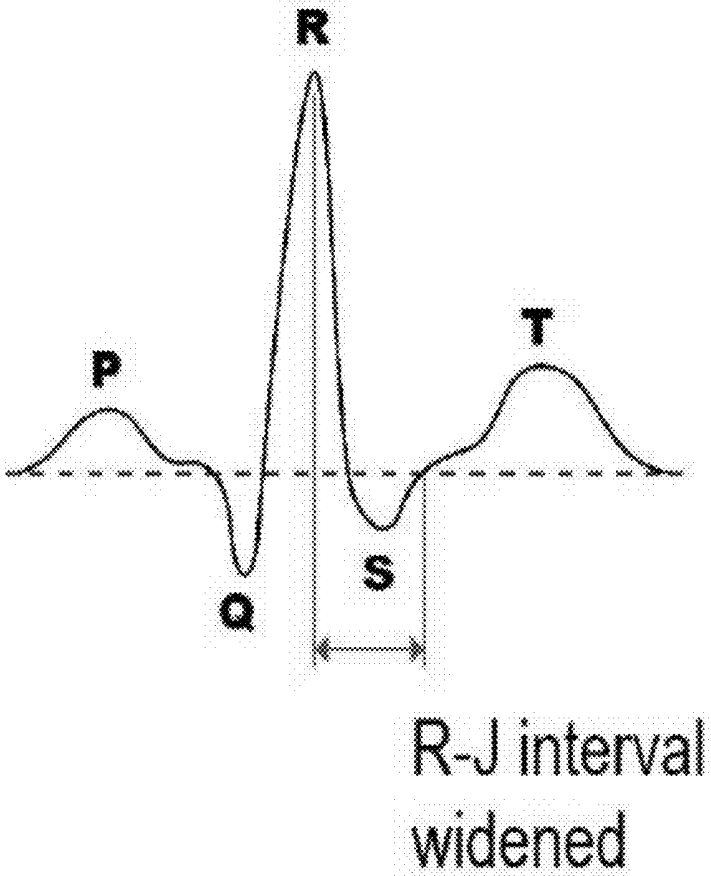

4900 

FIG. 49

AUTOMATED ECG ANALYSIS AND DIAGNOSIS SYSTEM

CROSS-REFERENCE TO RELATED APPLICATION

[0001] This application is a continuation in part of U.S. patent application Ser. No. 15/393,135, filed Dec. 28, 2016, which is a continuation in part of U.S. patent application Ser. No. 14/749,697, filed Jun. 25, 2015, now U.S. Pat. No. 9,538,930 (hereinafter the “930 Patent”), which is a continuation in part of U.S. patent application Ser. No. 14/662,996, filed Mar. 19, 2015, now U.S. Pat. No. 9,339,204 (hereinafter the “204 Patent”), which is a continuation of PCT Application No. PCT/US15/20828, filed Mar. 16, 2015, which claims the benefit of U.S. Provisional Patent Application Ser. No. 62/008,435, filed Jun. 5, 2014; this application also claims the benefit of U.S. Provisional Patent Application Ser. No. 62/463,662, filed Feb. 26, 2017; U.S. patent application Ser. No. application Ser. No. 15/393,135 claims the benefit of U.S. Provisional Patent Application Ser. No. 62/271,704, filed Dec. 28, 2015, and U.S. Provisional Patent Application Ser. No. 62/271,699, filed Dec. 28, 2015; and U.S. patent application Ser. No. 14/749,697 claims the benefit of U.S. Provisional Patent Application Ser. No. 62/017,185, filed Jun. 25, 2014, the content of all of which is incorporated by reference herein in their entireties.

INTRODUCTION

[0002] The teachings herein relate to an automated electrocardiography (ECG) analysis and diagnosis system. More particularly, the teachings herein relate to systems and methods for identifying and annotating cardiac electrophysiological signals in an ECG waveform as normal or abnormal during measurement of the ECG waveform. These systems and methods use the harmonic signals of a conventional ECG waveform and previously recorded data from normal and abnormal patients to identify and annotate the cardiac electrophysiological signals in the ECG waveform

[0003] The systems and methods herein can be performed in conjunction with a processor, controller, or computer system, such as the computer system of FIG. 1.

BACKGROUND

ECG Accuracy Problem

[0004] Since the first ECG instrument was invented in 1903, its accuracy rate for diagnosis has always been a problem in clinical applications. For people with abnormal conditions, ECG waveform variations are not the same for the same person and are not completely identical even for the same disease. They are at most self-similar. Self-similarly, for example, refers to an object having a shape that is similar to the shape of one of its parts. As a result, ECG science is one of the most complicated disciplines in medicine.

[0005] It can be seen from numerous signal processing methods that, during a lifetime, each beat of a person’s heart has different specific signal variation, and the difference is significant. However, generally one is unable to observe this from a conventional linear ECG waveform with the naked eye.

[0006] Since computers started to be widely used in ECG analysis the 1970s, people have been consistently exploring, searching, and studying how to automate ECG analysis and diagnosis. In the past half a century, thousands of scholars have made efforts in studying algorithms, exploring pattern recognition, and applying those in ECG mapping and automatic diagnosis.

[0007] However, wide clinical use of such systems has yet to be achieved. There are at least three technical reasons for this.

[0008] 1. The ECG waveform is morphological, and generally no consistent mapping points can be found. In other words, the information in the ECG waveform is conveyed through its structure or form. Also, the waveform is abstractly self-similar. In particular, there is no rule for abnormal variations, the time axis signals interfere with each other on left and right sides of as well as above the x-axis, non-linear variations are invisible, and the same disease may have hundreds of millions of variations, but they are not clearly displayed on the ECG waveform. As a result, all ECG parameters are, in general, not accurate, and it is almost impossible to measure these parameters after the waveform changes. Therefore, the highest accuracy of automatic diagnosis by existing ECG software reaches around 38%. Also, this accuracy is only achieved for simple ECG waveform variations and not for many complex waveforms. This is because no mapping point can be found due to the loss or disappearance or deformation of the P-QRS-T waveform.

[0009] 2. The second reason systems for automated ECG analysis and diagnosis have not been adopted clinically is related to how a conventional ECG waveform has been measured. As described in the ’204 Patent and below, the conventional ECG waveform is a single time domain waveform that represents a combination of many different frequency domain signals from different parts of the heart muscle. As a result, information specific to these different parts of the heart muscle are generally lost. In addition, the conventional ECG waveform is a linear waveform, while the heart is a nonlinear system, and the vast majority of variations as a result of abnormality are nonlinear.

[0010] 3. The third reason systems for automated ECG analysis and diagnosis have not been adopted clinically is related to the high number of false positives found in normal and abnormal populations. For example, in many cases, conventional ECG waveforms show abnormal results in tests of normal people and also show normal results in tests of abnormal people, which makes it extremely difficult for clinical reading and understanding and makes it impossible to determine whether a result is normal or abnormal.

[0011] However, the heart is an electrified organ, and there is no doubt that the electrophysiological responses of a heart organ are the fastest and most sensitive measurements to diagnose heart problems. ECG remains one of the most extensively used clinical tools used at present along with blood tests and imaging, despite the lack of accurate systems for automated ECG analysis and diagnosis. As a result, there is a significant need for such systems.

[0012] Recent advancements have addressed one of the three technical problems. This is the conventional ECG waveform measurement problem. As described in the ’204 Patent and below, an ECG device has been developed that uses signal processing to detect one or more subwaveforms within the P, Q, R, S, T, U, and J waveforms of a conven-

tional ECG waveform and/or within the intervals between the P, Q, R, S, T, U, and J waveforms of a conventional ECG waveform. In other words, the device of the '204 Patent can provide information (subwaveforms) about different frequency domain signals from different parts of the heart muscle. A waveform displaying these subwaveforms is referred to as a saah ECG waveform, for example. In FIG. 30, described below, portions of a saah ECG waveform 3030 and a conventional or traditional ECG waveform 3040 are compared. FIG. 30 shows that saah ECG waveform 3030 relates ECG signals more closely to the anatomy of self-conducting system 3020 than traditional ECG waveform 3040.

[0013] As described in the '930 Patent and below, one way the different frequency domain signals from different parts of the heart muscle can be measured is through multi-domain ECG. In multi-domain ECG heart signals are measured using different frequency bands. These multi-domain ECG heart signals can be displayed in one diagram as an electrophysiological waveform (EPCG) waveform. FIG. 32 shows EPCG waveforms before and after percutaneous coronary intervention (PCI), for example.

[0014] As a result of the systems of the '204 Patent the '930 Patent, the technical problem of measuring the different frequency domain signals from different parts of the heart muscle has been addressed. Additional systems, however, are needed to address further the technical problems of analyzing the shape and form of these frequency domain signals and distinguishing disease conditions from false positives in normal and abnormal populations using different frequency domain signals from different parts of the heart muscle.

ECG History

[0015] Electrical signals produced by a human heart were observed through electrodes attached to a patient's skin as early as 1879. Between 1897 and 1911 various methods were used to detect these electrical signals and record a heartbeat in real-time. In 1924, Willem Einthoven was awarded the Nobel Prize in medicine for identifying the various waveforms of a heartbeat and assigning the letters P, Q, R, S, T, U, and J to these waveforms. Since the early 1900s, the equipment used for electrocardiography (ECG or EKG) has changed. However, the basic waveforms detected and analyzed have not changed.

[0016] An ECG device detects electrical impulses or changes in the electrical potential between two electrodes attached to the skin of a patient as the heart muscle contracts or beats. Electrically, the contraction of the heart is caused by depolarization and repolarization of various parts of the heart muscle. Initially, or at rest, the muscle cells of the heart have a negative charge. In order to cause them to contract, they receive an influx of positive ions Na^+ and Ca^{++} . This influx of positive ions is called depolarization. The return of negative ions to bring the heart back to a resting state is called repolarization. Depolarization and repolarization of the heart affect different parts of the heart over time giving rise to the P, Q, R, S, T, U, and J waveforms.

[0017] FIG. 2 is an exemplary plot 200 of the P, Q, R, S, and T waveforms of a conventional ECG waveform of a heartbeat from a conventional ECG device. The P, Q, R, S, and T waveforms represent electrical conduction through a heart muscle. P waveform 210 represents the propagation of depolarization from the sinoatrial node, to the right and left

atria, and to the atrioventricular node. The sinoatrial node is also referred to as the sinus node, SA node, or SAN. The atrioventricular node is also referred to as the AV node or AVN. The right atrium is also referred to as the RA, and the left atrium is also referred to as the LA.

[0018] FIG. 3 is an exemplary diagram 300 of the depolarization of the muscle tissue of a heart that produces P waveform 210 of FIG. 2 as detected by a conventional ECG device. P waveform 210 of FIG. 2 is produced as depolarization propagates from SAN 310 to AVN 340 in FIG. 3. As depolarization propagates from SAN 310 to AVN 340, it also spreads from RA 320 to LA 340. P waveform 210 of FIG. 2 typically has a duration of 80 ms, for example.

[0019] PR segment 220 of FIG. 2 represents the propagation of depolarization from the AVN to the Bundle of His, and then to the Bundle Branches. PR segment 230 may also include depolarization to the Purkinje fibers of the inner ventricular walls. The Bundle of His is also referred to as the His Bundle or His. The Bundle Branches include the right bundle branches (RBB) and the left bundle branches (LBB). As shown in FIG. 2, in a conventional ECG, PR segment 220 shows up as a flat line or waveform with no amplitude.

[0020] FIG. 4 is an exemplary diagram 400 of the depolarization of the muscle tissue of a heart that produces PR segment 220 of FIG. 2 as detected by a conventional ECG device. PR segment 220 of FIG. 2 is produced as depolarization propagates from AVN 340 to His 450 and then to Bundle Branches 460 that include RBB 461 and LBB 462. PR segment 220 of FIG. 2 typically has a duration of between 50 and 120 ms, for example.

[0021] Waveforms Q 230, R 240, and S 250 of FIG. 2 form the QRS complex. The QRS complex represents the propagation of depolarization through the right and left ventricles. The right ventricle is also referred to as RV, and the left ventricle is referred to as LV.

[0022] FIG. 5 is an exemplary diagram 500 of the depolarization of the muscle tissue of a heart that produces Q waveform 230, R waveform 240, and S waveform 250 of FIG. 2 as detected by a conventional ECG device. Waveforms Q 230, R 240, and S 250 of FIG. 2 produced as depolarization propagates from Bundle Branches 460 through RV 571 and LV 572. RV 571 and LV 572 have the largest muscle mass in the heart. The QRS complex formed by waveforms Q 230, R 240, and S 250 of FIG. 2 typically has a duration of between 80 and 100 ms, for example.

[0023] ST segment 260 of FIG. 2 represents the period during which the ventricles remain depolarized and contracted. As shown in FIG. 2, in a conventional ECG, ST segment 260 shows up as a flat line or waveform with no amplitude. ST segment 260 typically has a duration of between 80 and 120 ms, for example.

[0024] The point in FIG. 2 at which the QRS complex ends and ST segment 260 begins is called J point 255. A J waveform (not shown) can sometimes appear as an elevated J point at J point 255 or as a secondary R waveform. A J waveform is usually characteristic of a specific disease. The J waveform is also referred to as the Osborn wave, camel-hump sign, sate delta wave, hathook junction, hypothermic wave, prominent J wave, K wave, H wave or current of injury.

[0025] T waveform 270 of FIG. 2 represents the repolarization or recovery of the ventricles. T waveform 270

typically has a duration of 160 ms, for example. The interval between the Q and T waveforms is referred to as the QT interval.

[0026] FIG. 6 is an exemplary diagram 600 of the repolarization of the muscle tissue of a heart that produces T waveform 270 of FIG. 2 as detected by a conventional ECG device. As shown in FIG. 6, RV 571 and LV 572 are repolarized.

[0027] Not shown in FIG. 2 is the U waveform. The U waveform sometimes appears after the T waveform. The U waveform is thought to represent repolarization of the interventricular septum, the papillary muscles, or the Purkinje fibers.

[0028] As shown in FIGS. 3 through 6, as a heart beats, electrical signals flow through all the different muscle tissues of the heart. As shown in FIG. 2, for the last 100 years conventional ECG devices have been able to detect some of these signals in the form of the P, Q, R, S, T, U, and J waveforms. These waveforms have aided in the diagnosis and treatment of many heart problems. Unfortunately, however, the P, Q, R, S, T, U, and J waveforms do not provide a complete picture of the operation of all the different muscle tissues of the heart. As a result, improved systems and methods are needed to detect and analyze more information from the electrical signals that flow through all the different muscle tissues of the heart as it is beating. This additional information can be used to diagnose and treat many more heart problems.

Artificial Intelligence

[0029] Artificial Intelligence (AI) generally refers to languages, algorithms, and operating systems that relate to how a computer system can carry out tasks that were previously only completed by relying on human intelligence. It is a general term and often does not include implementation or application. The definition of AI has evolved over time, however, and this phenomenon is referred to as the "AI effect." The AI effect can be summarized as the prescription that "AI intends to complete a collection of all tasks that cannot be implemented without relying on human intelligence at the present." In the 1940s and 1950s, a group of scientists from different fields (mathematics, psychology, engineering, economics and politics) began to explore the possibility of manufacturing an artificial brain. In 1956, AI was established as a discipline. The organizers of the 1956 Dartmouth Artificial Intelligence Conference were Marvin Minsky, John McCarthy, and two other senior scientists, Claude Shannon and Nathan Rochester, with the latter coming from IBM. At the 1956 Dartmouth Artificial Intelligence Conference, the name and tasks of AI were determined, and at the same time, initial achievements and the earliest group of researchers appeared. As a result, this event has been extensively acknowledged as a sign of the birth of AI. It is clear that AI is now a technological field, a second revolution since the invention of the computer, and a certain trend in the future. It is being applied in all industries, exists everywhere, and is used on almost everything on the earth. In the medical field, AI is now used in the following: medical imaging, sensor-based data analysis, conversion of bioinformatics, and development of public health policies. AI is also used in the clinical applications. These applications include cancer treatment: recognition of mitosis of cancerous tumor cells, identification of disease types and degrees of aggravation, shortening chemotherapy time, and mitigating dam-

age caused by chemotherapy for cancer patients. These applications also include ophthalmological diagnosis: recognition of early signs of eye disease, such as senile macular degeneration, and diabetic retinopathy and surgical treatment: AI surgical robots, etc. Google has also formed a team called DeepMind Health, which cooperated with the Imperial College London and the Royal Free Hospital in London, UK. They released a mobile application called Streams, and medical professionals can use Streams to observe treatment results in a faster manner. Overall, in the medical field, the AI system can be used on any job that previously required human thinking.

BRIEF DESCRIPTION OF THE DRAWINGS

[0030] FIG. 1 is a block diagram that illustrates a computer system, in accordance with various embodiments.

[0031] FIG. 2 is an exemplary plot of the P, Q, R, S, and T waveforms of a conventional electrocardiography (ECG) waveform of a heartbeat from a conventional ECG device.

[0032] FIG. 3 is an exemplary diagram of the depolarization of the muscle tissue of a heart that produces the P waveform of FIG. 2 as detected by a conventional ECG device.

[0033] FIG. 4 is an exemplary diagram of the depolarization of the muscle tissue of a heart that produces the PR segment of FIG. 2 as detected by a conventional ECG device.

[0034] FIG. 5 is an exemplary diagram of the depolarization of the muscle tissue of a heart that produces the Q waveform, the R waveform, and the S waveform of FIG. 2 as detected by a conventional ECG device.

[0035] FIG. 6 is an exemplary diagram of the repolarization of the muscle tissue of a heart that produces the T waveform of FIG. 2 as detected by a conventional ECG device.

[0036] FIG. 7 is a block diagram of a conventional ECG device.

[0037] FIG. 8 is a block diagram of an ECG device for detecting more information from the electrical signals that flow through all the different muscle tissues of the heart as it is beating, in accordance with various embodiments.

[0038] FIG. 9 is an exemplary plot of a saah ECG waveform of a heartbeat from a saah ECG device showing subwaveforms found within the P, Q, R, S, T, U, and J waveforms and/or within the intervals between the P, Q, R, S, T, U, and J waveforms, in accordance with various embodiments.

[0039] FIG. 10 is an exemplary block diagram showing a signal processing algorithm for detecting five subwaveforms within the PR interval of a conventional ECG waveform, in accordance with various embodiments.

[0040] FIG. 11 is an exemplary block diagram of a saah ECG device that displays conventional ECG waveforms, saah ECG waveforms, and saah ECG data, in accordance with various embodiments.

[0041] FIG. 12 is an exemplary plot of the information displayed by the saah ECG device of FIG. 10, in accordance with various embodiments.

[0042] FIG. 13 is an exemplary block diagram of a saah ECG device that displays conventional ECG waveforms, saah ECG waveforms, saah ECG data, and saah ECG automatic pattern recognition diagnosis information, in accordance with various embodiments.

[0043] FIG. 14 is an exemplary plot of a conventional ECG waveform showing how a small error in the starting point of the P wave can cause a large error in all subsequent time measurements, in accordance with various embodiments.

[0044] FIG. 15 is an exemplary plot of a conventional ECG waveform showing how the end of the PR interval cannot be confirmed due to an upward arc angle of the starting point of QRS wave, in accordance with various embodiments.

[0045] FIG. 16 is a flowchart showing a method for detecting subwaveforms within the P, Q, R, S, T, U, and J waveforms of an ECG waveform of a heartbeat or in an interval between the P, Q, R, S, T, U, and J waveforms, in accordance with various embodiments.

[0046] FIG. 17 is a schematic diagram of a system that includes one or more distinct software modules that perform a method for detecting subwaveforms within the P, Q, R, S, T, U, and J waveforms of an ECG waveform of a heartbeat or in an interval between the P, Q, R, S, T, U, and J waveforms, in accordance with various embodiments.

[0047] FIG. 18 is an exemplary block diagram showing a system for performing multi-domain ECG using 16 different frequency bands or domains, in accordance with various embodiments.

[0048] FIG. 19 is an exemplary plot of a multi-domain ECG waveform that includes 10 different time domain signals, in accordance with various embodiments.

[0049] FIG. 20 is an exemplary plot of a multi-domain ECG waveform that includes 14 different time domain signals, in accordance with various embodiments.

[0050] FIG. 21 is an exemplary alignment of a multi-domain ECG waveform that includes 16 different time domain signals with a conventional ECG waveform, in accordance with various embodiments.

[0051] FIG. 22 is an exemplary plot of a conventional ECG waveform showing how the ST segment of a normal person can appear abnormal, in accordance with various embodiments.

[0052] FIG. 23 is an exemplary plot of a conventional ECG waveform showing how the T wave of an abnormal person can appear normal, in accordance with various embodiments.

[0053] FIG. 24 is an exemplary plot of a conventional ECG waveform showing how the section of an autonomic conduction system cannot be determined from a conduction block, in accordance with various embodiments.

[0054] FIG. 25 is an exemplary plot of a conventional ECG waveform showing how the QRS complex is widened in the waveform, in accordance with various embodiments.

[0055] FIG. 26 is an exemplary plot 2600 of a conventional ECG waveform showing how the atrial anatomical positions are difficult to identify, in accordance with various embodiments.

[0056] FIG. 27 is an exemplary plot of a conventional ECG waveform showing a premature ventricular beat, in accordance with various embodiments. In plot.

[0057] FIG. 28 is an exemplary plot of a conventional ECG waveform showing in atrial conduction block, in accordance with various embodiments.

[0058] FIG. 29 is an exemplary diagram of the anatomy of the self-conducting system of a heart, in accordance with various embodiments.

[0059] FIG. 30 is an exemplary diagram showing the anatomic sites that the PA, AH, and HV intervals represent and the corresponding PA, AH, and HV intervals in a saah ECG waveform and traditional ECG waveform, in accordance with various embodiments.

[0060] FIG. 31 is an exemplary comparison plot of a saah ECG waveform and a traditional ECG waveform with PA, AH, HV, and PR interval values obtained from aiECG processing for a patient with a normal heart, in accordance with various embodiments.

[0061] FIG. 32 is an exemplary comparison plot of a multi-domain ECG or electrophysiogram (EPCG) waveform aligned with a traditional ECG waveform for a patient with acute coronary syndrome (ACS) before and after percutaneous coronary intervention (PCI), in accordance with various embodiments.

[0062] FIG. 33 is an exemplary diagram showing timing values of conduction calculated at various anatomic sites along the self-conduction system of a normal heart by further processing a traditional ECG waveform, in accordance with various embodiments.

[0063] FIG. 34 is an exemplary block diagram of a system for automated ECG analysis and diagnosis using AI, in accordance with various embodiments.

[0064] FIG. 35 is an exemplary plot of a conventional ECG waveform annotated with diagnosis marker information, in accordance with various embodiments.

[0065] FIG. 36 is an exemplary comparison of timing information from a conventional ECG waveform and from an ECG waveform produced and annotated using an automated analysis and diagnosis system, in accordance with various embodiments.

[0066] FIG. 37 is a block diagram of an ECG system for identifying and annotating cardiac electrophysiological signals in an ECG waveform as normal or abnormal during measurement of the ECG waveform, in accordance with various embodiments.

[0067] FIG. 38 is a flowchart showing a method for identifying and annotating cardiac electrophysiological signals in an ECG waveform as normal or abnormal during measurement of the ECG waveform, in accordance with various embodiments.

[0068] FIG. 39 is an exemplary ECG waveform plot showing the relative positions of the PR and ST segments for a normal heartbeat, in accordance with various embodiments.

[0069] FIG. 40 is an exemplary ECG waveform plot showing how the ST segment can shift vertically due to abnormal conditions, in accordance with various embodiments.

[0070] FIG. 41 is an exemplary ECG waveform plot showing how the ST segment can be deformed due to abnormal conditions, in accordance with various embodiments.

[0071] FIG. 42 is an exemplary ECG waveform plot showing how the vertical or horizontal movement of the end of an RS segment can affect the ST segment due to abnormal conditions, in accordance with various embodiments.

[0072] FIG. 43 is an exemplary ECG waveform plot showing how the ST segment can shift horizontally due to abnormal conditions, in accordance with various embodiments.

[0073] FIG. 44 is an exemplary ECG waveform plot showing how vertical or horizontal movement of the J point

can affect the ST segment due to abnormal conditions, in accordance with various embodiments.

[0074] FIG. 45 is an exemplary comparison of two ECG waveform plots exhibiting ST segment changes that can be identified using the STy standard, in accordance with various embodiments

[0075] FIG. 46 is an exemplary comparison of two ECG waveform plots exhibiting ST segment changes that can be identified using the STx standard, in accordance with various embodiments.

[0076] FIG. 47 is an exemplary comparison of two ECG waveform plots exhibiting ST segment changes that can be identified using the STs and STy standards (STs+STy), in accordance with various embodiments.

[0077] FIG. 48 is an exemplary comparison of two ECG waveform plots exhibiting ST segment changes that can be identified using the STj, STy, and STx standards (STj+STy+STx), in accordance with various embodiments.

[0078] FIG. 49 is an exemplary ECG waveform plot of an ST segment change that can be identified using the STx and STj standards (STx+STj), in accordance with various embodiments.

[0079] Before one or more embodiments of the invention are described in detail, one skilled in the art will appreciate that the invention is not limited in its application to the details of construction, the arrangements of components, and the arrangement of steps set forth in the following detailed description. The invention is capable of other embodiments and of being practiced or being carried out in various ways. Also, it is to be understood that the phraseology and terminology used herein is for the purpose of description and should not be regarded as limiting.

DETAILED DESCRIPTION

Computer-Implemented System

[0080] FIG. 1 is a block diagram that illustrates a computer system 100, upon which embodiments of the present teachings may be implemented. Computer system 100 includes a bus 102 or other communication mechanism for communicating information, and a processor 104 coupled with bus 102 for processing information. Computer system 100 also includes a memory 106, which can be a random access memory (RAM) or other dynamic storage device, coupled to bus 102 for storing instructions to be executed by processor 104. Memory 106 also may be used for storing temporary variables or other intermediate information during execution of instructions to be executed by processor 104. Computer system 100 further includes a read only memory (ROM) 108 or other static storage device coupled to bus 102 for storing static information and instructions for processor 104. A storage device 110, such as a magnetic disk or optical disk, is provided and coupled to bus 102 for storing information and instructions.

[0081] Computer system 100 may be coupled via bus 102 to a display 112, such as a cathode ray tube (CRT) or liquid crystal display (LCD), for displaying information to a computer user. An input device 114, including alphanumeric and other keys, is coupled to bus 102 for communicating information and command selections to processor 104. Another type of user input device is cursor control 116, such as a mouse, a trackball or cursor direction keys for communicating direction information and command selections to processor 104 and for controlling cursor movement on

display 112. This input device typically has two degrees of freedom in two axes, a first axis (i.e., x) and a second axis (i.e., y), that allows the device to specify positions in a plane.

[0082] A computer system 100 can perform the present teachings. Consistent with certain implementations of the present teachings, results are provided by computer system 100 in response to processor 104 executing one or more sequences of one or more instructions contained in memory 106. Such instructions may be read into memory 106 from another computer-readable medium, such as storage device 110. Execution of the sequences of instructions contained in memory 106 causes processor 104 to perform the process described herein. Alternatively, hard-wired circuitry may be used in place of or in combination with software instructions to implement the present teachings. Thus implementations of the present teachings are not limited to any specific combination of hardware circuitry and software.

[0083] In various embodiments, computer system 100 can be connected to one or more other computer systems, like computer system 100, across a network to form a networked system. The network can include a private network or a public network such as the Internet. In the networked system, one or more computer systems can store and serve the data to other computer systems. The one or more computer systems that store and serve the data can be referred to as servers or the cloud, in a cloud computing scenario. The other computer systems that send and receive data to and from the servers or the cloud can be referred to as client or cloud devices, for example.

[0084] The term “computer-readable medium” as used herein refers to any media that participates in providing instructions to processor 104 for execution. Such a medium may take many forms, including but not limited to, non-volatile media, volatile media, and transmission media. Non-volatile media includes, for example, optical or magnetic disks, such as storage device 110. Volatile media includes dynamic memory, such as memory 106. Transmission media includes coaxial cables, copper wire, and fiber optics, including the wires that comprise bus 102.

[0085] Common forms of computer-readable media or computer program products include, for example, a floppy disk, a flexible disk, hard disk, magnetic tape, or any other magnetic medium, a CD-ROM, digital video disc (DVD), a Blu-ray Disc, any other optical medium, a thumb drive, a memory card, a RAM, PROM, and EPROM, a FLASH-EPROM, any other memory chip or cartridge, or any other tangible medium from which a computer can read.

[0086] Various forms of computer-readable media may be involved in carrying one or more sequences of one or more instructions to processor 104 for execution. For example, the instructions may initially be carried on the magnetic disk of a remote computer. The remote computer can load the instructions into its dynamic memory and send the instructions over a telephone line using a modem. A modem local to computer system 100 can receive the data on the telephone line and use an infra-red transmitter to convert the data to an infra-red signal. An infra-red detector coupled to bus 102 can receive the data carried in the infra-red signal and place the data on bus 102. Bus 102 carries the data to memory 106, from which processor 104 retrieves and executes the instructions. The instructions received by memory 106 may optionally be stored on storage device 110 either before or after execution by processor 104.

[0087] In accordance with various embodiments, instructions configured to be executed by a processor to perform a method are stored on a computer-readable medium. The computer-readable medium can be a device that stores digital information. For example, a computer-readable medium includes a compact disc read-only memory (CD-ROM) as is known in the art for storing software. The computer-readable medium is accessed by a processor suitable for executing instructions configured to be executed.

[0088] The following descriptions of various implementations of the present teachings have been presented for purposes of illustration and description. It is not exhaustive and does not limit the present teachings to the precise form disclosed. Modifications and variations are possible in light of the above teachings or may be acquired from practicing of the present teachings. Additionally, the described implementation includes software but the present teachings may be implemented as a combination of hardware and software or in hardware alone. The present teachings may be implemented with both object-oriented and non-object-oriented programming systems.

Subwaveform Detection of the P, Q, R, S, T, U, and J Waveforms

[0089] As described above, electrical signals flow through all the different muscle tissues of the heart. For the last 100 years, conventional ECG devices have been able to detect some of these signals in the form of the P, Q, R, S, T, U, and J waveforms. These waveforms have aided in the diagnosis and treatment of many heart problems.

[0090] Unfortunately, however, the P, Q, R, S, T, U, and J waveforms do not provide a complete picture of the operation of all the different muscle tissues of the heart. As a result, improved systems and methods are needed to detect and analyze more information from the electrical signals that flow through all the different muscle tissues of the heart as it is beating. This additional information can be used to diagnose and treat many more heart problems.

[0091] In various embodiments, additional information is obtained from the electrical signals produced by a heart through signal processing. More specifically, signal processing is added to an ECG device in order to detect more information from the electrical signals that flow through all the different muscle tissues of the heart as it is beating.

[0092] FIG. 7 is a block diagram 700 of a conventional ECG device. The conventional ECG device includes two or more leads or electrodes 710. Electrodes 710 are typically attached to the skin of a patient. Electrical signals produced by a beating heart are detected between pairs of electrodes 710. Because the heart is three-dimensional, electrodes are attached at different locations on a body to detect signals at different corresponding locations or angles from the heart. In other words, the electrodes are placed on a body to partially surround the heart. One typical type of ECG includes 12 electrodes, for example.

[0093] A voltage signal is detected between two electrodes 710 by detector 720. Detector 720 also typically amplifies the voltage signal. Detector 720 can also convert the voltage signal to a digital voltage signal using an analog to digital converter (A/D).

[0094] Detector 720 provides the detected and amplified voltage signal from each pair of electrodes 710 to display 730. Display 730 can be an electronic display device including, but not limited to, a cathode ray tube (CRT) device, light

emitting diode (LED) device, or Liquid crystal display (LCD) device. Display 730 can also be a printer device. Additionally, display 730 can include a memory device to record detected signals. The memory device can be, but is not limited to, a volatile electronic memory, such as random access memory (RAM), a non-volatile electronic memory, such as electrically erasable programmable read-only memory (EEPROM or flash memory), or a magnetic hard drive.

[0095] Display 730 displays a continuous loop of the detected P, Q, R, S, T, U, and J waveforms as shown in FIG. 2 for each pair of electrodes 710. Modern ECG devices can also include a processor (not shown), such as the processor shown in FIG. 1, to analyze the P, Q, R, S, T, U, and J waveforms. For example, the processor can calculate the time periods of the P, Q, R, S, T, U, and J waveforms and the times between the P, Q, R, S, T, U, and J waveforms. The processor can also compare this timing information to stored normal information. Based on the comparison, the processor can determine differences from the normal data. All information calculated by the processor can also be displayed on display 730.

[0096] FIG. 8 is a block diagram 800 of an ECG device for detecting more information from the electrical signals that flow through all the different muscle tissues of the heart as it is beating, in accordance with various embodiments. Electrodes 810 are attached to the skin of a patient, for example. Electrical signals produced by a beating heart are detected between pairs of electrodes 810.

[0097] A voltage signal is detected between two electrodes 810 by detector 820. Detector 820 also amplifies the voltage signal. Detector 820 also converts the voltage signal to a digital voltage signal using an analog to digital converter (A/D).

[0098] Detector 820 provides the detected and amplified voltage signal from each pair of electrodes 810 to signal processor 830. Detector 820 can also provide the detected and amplified voltage signal from each pair of electrodes 810 directly to display device 840 to display the conventional P, Q, R, S, T, U, and J waveforms.

[0099] Signal processor 830 detects or calculates one or more subwaveforms within and/or in the interval between the P, Q, R, S, T, U, and J waveforms of each detected and amplified voltage signal. A waveform is a shape or form of a signal. A subwaveform is shape or form of a signal that is within or part of another signal.

[0100] Signal processor 830 can be a separate electronic device that can include, but is not limited to, an application specific integrated circuit (ASIC), a field programmable gate array (FPGA), or a general purpose processor. Signal processor 830 can be software implemented on another processor of the ECG device, such as a processor of display device 840. Signal processor 830 can also be a remote server that receives the detected and amplified voltage signal from detector 820, detects or calculates one or more subwaveforms within and/or in the interval between the P, Q, R, S, T, U, and J waveforms, and sends the detected and amplified voltage signal and the one or more subwaveforms to display device 840.

[0101] Signal processor 830 sends one or more subwaveforms of each detected and amplified voltage signal to display device 840. Signal processor 830 can also calculate and send to the display device 840 the time periods of the one or more subwaveforms, the times between the one or

more subwaveforms, and the times of the one or more subwaveforms in relation to the P, Q, R, S, T, U, and J waveforms and or the intervals between the P, Q, R, S, T, U, and J waveforms. Signal processor **830** can also compare this timing information to stored normal timing information. Based on the comparison, signal processor **830** can determine differences from the normal data and send this difference information and any of the timing information to display device **840**.

[**0102**] Display device **840** displays a continuous loop of the one or more subwaveforms for each pair of electrodes **810**. Display device **840** can also display part or all of the conventional P, Q, R, S, T, U, and J waveforms for comparison with the one or more subwaveforms. Like display **730** of FIG. 7, display device **840** of FIG. 8 can be an electronic display device, a printer, or any combination of the two.

[**0103**] In various embodiments, an ECG device using signal processing to detect one or more subwaveforms within the P, Q, R, S, T, U, and J waveforms and/or within the intervals between the P, Q, R, S, T, U, and J waveforms is herein referred to as a saah ECG device. The voltage difference signals produced by a saah ECG device are referred to as saah ECG waveforms. The term “saah” is an acronym for some of the anatomically distinct portions of muscle tissue that produce subwaveforms. Specifically, saah stands for sinoatrial node (SAN), atria (right atrium (RA) and left atrium (LA)), atrioventricular node (AVN), and bundle of His (HIS). However, a saah ECG waveform is not limited to including subwaveforms representing the SAN, the atria, the AVN, and the HIS. A saah ECG waveform can include any subwaveform the P, Q, R, S, T, U, and J waveforms and/or within the intervals between the P, Q, R, S, T, U, and J waveforms.

[**0104**] FIG. 9 is an exemplary plot **900** of a saah ECG waveform of a heartbeat from a saah ECG device showing subwaveforms found within the P, Q, R, S, T, U, and J waveforms and/or within the intervals between the P, Q, R, S, T, U, and J waveforms, in accordance with various embodiments. For example, five subwaveforms **910-950** of FIG. 9 are detected within the P waveform and the PR segment. The time period that includes the P waveform and the PR segment is also called the PR interval. Subwaveform **910** represents the depolarization of the SAN. Subwaveform **920** represents the depolarization of RA and LA. Subwaveform **930** represents the depolarization of the AVN. Subwaveform **940** represents the depolarization HIS. Finally, subwaveform **950** represents the depolarization of the bundle branches (BB).

[**0105**] In various embodiments, the subwaveforms of a saah ECG waveform are detected using signal processing. Electrodes **810** of the saah ECG of FIG. 8, for example, receive electrical impulses from anatomically distinct portions of muscle tissue or cells. The electrical impulses of anatomically distinct portions of muscle tissue of the heart have distinct frequencies. Through animal and human experimentation, the distinct frequency, frequency range, or frequency band of the anatomically distinct portions of muscle tissue of the heart are found. These distinct frequency bands of anatomically distinct portions of muscle tissue of the heart provide predetermined data or information for signal processing. In other words, the band pass frequency filtering of the signal processing is determined from the experimental data collected. A saah ECG device then

employs one or more frequency band pass filters to detect the one or more subwaveforms.

[**0106**] FIG. 10 is an exemplary block diagram **1000** showing a signal processing algorithm for detecting five subwaveforms within the PR interval of a conventional ECG waveform, in accordance with various embodiments. Sampling block **1010** samples the electrical impulses in the PR interval time period of each heart. This is shown graphically in FIG. 1000 by separating PR interval **1020** from ECG waveform **200**. The electrical impulses in the PR interval time period are sampled using electrodes **810** and detector **820** of FIG. 8, for example. Detector **820** of FIG. 8 can also amplify and convert the analog signal into a digital signal for digital processing.

[**0107**] The signal processing can be performed directly on the time domain signal received from a detector or the time domain signal received from a detector can be converted to the frequency domain for algorithmic processing. In FIG. 10, block **1030** converts the PR interval time domain signal to a PR interval frequency domain signal. The time domain signal is converted into a frequency domain signal using a Fourier transform, for example.

[**0108**] As described above, through animal and/or human experimentation, the frequency bands associated with depolarization of the SAN, atria, AVN, HIS, and BB of the heart are determined. Based on these frequency bands, band pass filters are created. Blocks **1041-1045** represent the band pass filters created to filter the PR interval frequency domain signal for frequency bands of the SAN, atria, AVN, HIS, and BB of the heart, respectively.

[**0109**] In block **1050**, the frequency domain subwaveforms detected from the band pass filtering the frequency bands of the SAN, atria, AVN, HIS, and BB of the heart are summed. In block **1060**, the filtered and summed frequency domain signal of the PR interval is converted back to a time domain signal. The frequency domain signal is converted into a time domain signal using a Fourier transform, for example.

[**0110**] The PR interval filtered and summed time domain signal **1070** includes five time domain subwaveforms **910-950**. Subwaveforms **910-950** represent depolarization of the SAN, atria, AVN, HIS, and BB of the heart, respectively. Time domain signal **1070** can be used to replace PR interval **1020** in ECG waveform **200**, for example. As a result, a saah ECG waveform is produced.

[**0111**] FIG. 10 shows a signal processing algorithm for detecting five subwaveforms. However, similar steps can be applied to detect fewer than five waveforms or more than five waveforms. Also, the steps of FIG. 10 describe detecting subwaveforms within the PR interval. However, similar steps can be applied to detect subwaveforms within the P, Q, R, S, T, U, and J waveforms and/or within one or more of the intervals between the P, Q, R, S, T, U, and J waveforms. In addition, the steps of FIG. 10 describe converting time signals to the frequency domain and then back to the time domain. One of ordinary skill in the art can appreciate that band pass filters can be applied directly to the time domain signal to provide the same result.

[**0112**] FIG. 11 is an exemplary block diagram **1100** of a saah ECG device that displays conventional ECG waveforms, saah ECG waveforms, and saah ECG data, in accordance with various embodiments. In block **1110**, patient heart signals are obtained. These heart signals can be obtained through noninvasive electrodes placed on the skin,

such as electrodes **810** shown in FIG. **8**. In various embodiments, heart signals may also be obtained using invasive electrodes placed directly on the heart. In block **1120**, the heart signals are detected using a detector and amplified.

[**0113**] In block **1130**, the detected and amplified heart signals are processed using a signal processor. The signal processor detects the conventional P, Q, R, S, T, U, and J waveforms and sends them to the display of block **1160**. The signal processor also detects or calculates subwaveforms within the conventional P, Q, R, S, T, U, and J waveforms and/or within intervals between the conventional P, Q, R, S, T, U, and J waveforms. The signal processor sends the subwaveforms to block **1140** for further processing. The processor of block **1140** produces the saah ECG waveform that includes the subwaveforms and sends the saah ECG waveform to the display of block **1160**. The processor of block **1140** calculates additional information or new data from the saah ECG waveform. This new data can include, but is not limited to, timing information about the subwaveforms, timing information about the intervals between the subwaveforms, and timing information about the subwaveforms and their relation to the conventional P, Q, R, S, T, U, and J waveforms. In block **1150**, this new data is sent to the display of block **1160**.

[**0114**] The display of block **1160** displays a continuous loop of the conventional ECG waveform, the saah ECG waveform, and the new data from the subwaveforms. The display of block **1160** can display this information on an electronic display or print it on paper. The display of block **1160** can also record this information. The display of block **1160** can record this information on any type of memory device.

[**0115**] FIG. **12** is an exemplary plot **1200** of the information displayed by the saah ECG device of FIG. **11**, in accordance with various embodiments. Plot **1200** includes conventional ECG waveform **1210** and saah ECG waveform **1220**. Saah ECG waveform **1220**, for example, includes, among others, five subwaveforms A-E representing the depolarization of the SAN, the RA and LA, the AVN, the HIS, and the BB, respectively.

[**0116**] Plot **1200** also shows new data or timing information about the subwaveforms and their relation to the conventional P, Q, R, S, T, U, and J waveforms. For example, the time interval between line **1231** and line **1232** relates subwaveform A of saah ECG waveform **1220** to P waveform **1240** of conventional ECG waveform **1210**. The time interval between line **1232** and line **1233** relates subwaveforms B and C of saah ECG waveform **1220** to P waveform **1240** conventional ECG waveform **1210**. The time interval between line **1233** and line **1234** relates subwaveforms D and E of saah ECG waveform **1220** to PR segment **1250** conventional ECG waveform **1210**.

[**0117**] FIG. **13** is an exemplary block diagram **1300** of a saah ECG device that displays conventional ECG waveforms, saah ECG waveforms, saah ECG data, and saah ECG automatic pattern recognition diagnosis information, in accordance with various embodiments. In block **1310**, patient heart signals are obtained. These heart signals can be obtained through noninvasive electrodes placed on the skin, such as electrodes **810** shown in FIG. **8**. In various embodiments, heart signals may also be obtained using invasive electrodes placed directly on the heart. In block **1320**, the heart signals are sampled or detected using a detector. The heart signals may also be amplified.

[**0118**] In block **1330**, the sampled heart signals are processed using a signal processor. The signal processor produces four different types of information from the sampled heart signals. As shown in block **1340**, the signal processor produces conventional ECG waveforms including the conventional P, Q, R, S, T, U, and J waveforms and sends them to display **1380**. As shown in block **1350**, the signal processor produces saah ECG waveforms. These saah ECG waveforms include subwaveforms of the conventional P, Q, R, S, T, U, and J waveforms and the intervals between them. Note that the arrow between blocks **1330** and **1350** show information following in both directions. This shows that information from the saah ECG waveforms is further analyzed by the signal processor.

[**0119**] As shown in block **1360**, the signal processor further analyzes the saah ECG waveforms to produce saah ECG data. This saah ECG data is sent to display **1380**. Additionally, as shown in block **1370**, the signal processor further analyzes the saah to obtain endocardium and epicardium data. This data is compared to recorded normal and abnormal data. The signal processor then produces automatic pattern recognition diagnosis (APD) information, and this information is sent to display **1380**. APD information is, for example, patterns and/or colors that allow a user to easily and quickly determine that normal or abnormal endocardium and/or epicardium data was found.

[**0120**] Systems and methods for detecting ECG subwaveforms are described in the '204 Patent, which is incorporated by reference in its entirety.

System for Detecting ECG Subwaveforms

[**0121**] In various embodiments, an electrocardiography (ECG) system for detecting one or more subwaveforms within the P, Q, R, S, T, U, and J waveforms or in an interval between the P, Q, R, S, T, U, and J waveforms is provided. Returning to FIG. **8**, the ECG system includes two or more electrodes **810**, a detector **820**, a signal processor **830**, and a display device **840**.

[**0122**] Two or more electrodes **810** are placed near a beating heart and receive electrical impulses from the beating heart. Two or more electrodes **810** are shown in FIG. **8** as noninvasive electrodes that are attached to the skin of a patient. In various embodiments, two or more electrodes **810** can be invasive electrodes placed directly on or within heart tissue.

[**0123**] Detector **820** is electrically connected to two or more electrodes **810**. Detector **820** detects the electrical impulses from at least one pair of electrodes of the two or more electrodes **810**. Detector **820** converts the electrical impulses to an ECG waveform for each heartbeat of the beating heart. Detector **820**, for example, samples the electrical impulses. In various embodiments, detector **820** further amplifies the ECG waveform. In various embodiments, detector **820** further performs analog to digital (A/D) conversion on the ECG waveform. In various embodiments, detector **820** provides an ECG waveform with a higher signal-to-noise (S/N) ratio than conventional ECG devices.

[**0124**] Signal processor **830** is electrically connected to detector **820**. Signal processor **830** receives the ECG waveform from detector **820**. Signal processor **830** detects or calculates one or more subwaveforms within P, Q, R, S, T, U, and J waveforms of the ECG waveform or in an interval between the P, Q, R, S, T, U, and J waveforms that represent the depolarization or repolarization of anatomically distinct

portions of muscle tissue of the beating heart. Signal processor **830** produces a processed ECG waveform that includes the one or more subwaveforms for each heartbeat.

[0125] Signal processor **830** can be a separate device, can be software running on a device of detector **820** or display device **840**, or can be software running on a remote server and communicating with detector **820** and display device **840** through one or more communication devices. Signal processor **830** can be a separate device that includes, but is not limited to, an application specific integrated circuit (ASIC) or a field programmable gate array (FPGA) or a general purpose processor. A general purpose processor can include, but is not limited to, a microprocessor, a microcontroller, or a computer such as the system shown in FIG. 1. Signal processor **830** can be software implemented on another processor of the ECG device, such as a processor of display device **840**. Signal processor **830** can also be a remote server that receives the detected and amplified difference voltage signal from detector **820**, detects or calculates one or more subwaveforms within and/or in the interval between the P, Q, R, S, T, U, and J waveforms, and sends the detected and amplified different voltage signal and the one or more subwaveforms to display device **840**.

[0126] Display device **840** receives the processed ECG waveform for each heartbeat and displays the processed ECG waveform for each heartbeat. The processed ECG waveform is called a saah ECG waveform, for example. As described above, display device **840** can be an electronic display device including, but not limited to, a cathode ray tube (CRT) device, light emitting diode (LED) device, or Liquid crystal display (LCD) device. Display device **840** can also be a printer device or any combination of an electronic display device and a printer. Additionally, display device **840** can include a memory device to record saah ECG waveforms, saah ECG data and conventional ECG waveforms and data. The memory device can be, but is not limited to, a volatile electronic memory, such as random access memory (RAM), a non-volatile electronic memory, such as electrically erasable programmable read-only memo (EEPROM or Flash memory), or a magnetic hard drive.

[0127] In various embodiments, the detected one or more subwaveforms include at least one subwaveform representing depolarization of the sinoatrial node (SAN), the atria (right atrium (RA) and left atrium (LA)), the atrioventricular node (AVN), the bundle of His (HIS), or the bundle branches (BB) of the beating heart.

[0128] In various embodiments, the display device **840** further displays the ECG waveform for comparison with the processed ECG waveform.

[0129] In various embodiments, signal processor **830** further calculates timing information about the one or more subwaveforms, timing information about the intervals between the one or more subwaveforms, and timing information about the one or more subwaveforms and their relation to the P, Q, R, S, T, U, and J waveforms of the ECG waveform for each heartbeat. Display device **840** further receives this timing information from signal processor **830**. Display device **840** displays the timing information about the one or more subwaveforms, the timing information about the intervals between the one or more subwaveforms, and the timing information about the one or more subwaveforms and their relation to the P, Q, R, S, T, U, and J waveforms of the ECG waveform for each heartbeat.

[0130] In various embodiments, the ECG system further includes a memory device (not shown). The memory device receives the ECG waveform and the processed ECG waveform from the signal processor.

[0131] In various embodiments, the memory device further includes normally processed ECG waveform data. Normally processed ECG waveform data is stored on the memory device using signal processor **830** or a general-purpose processor (not shown). Signal processor **830** further compares the processed ECG waveform to the normally processed ECG waveform data and calculates a status condition based on the comparison. The status conditions are, for example, normal, suspicious, or abnormal.

[0132] In various embodiments, the ECG system includes a second display device (not shown) surrounding a rotating button (not shown). Signal processor **830** further sends a colored pattern to the second display device based on the status condition. The second display device provides automatic pattern recognition diagnosis (APD).

Method for Detecting ECG Subwaveforms

[0133] FIG. 16 is a flowchart showing a method **1600** for detecting subwaveforms within the P, Q, R, S, T, U, and J waveforms of an ECG waveform of a heartbeat or in an interval between the P, Q, R, S, T, U, and J waveforms, in accordance with various embodiments.

[0134] In step **1610** of method **1600**, electrical impulses are detected between at least one pair of electrodes of two or more electrodes placed proximate to a beating heart using a detector. The electrical impulses are converted to an ECG waveform for each heartbeat of the beating heart using the detector.

[0135] In step **1620**, the ECG waveform for each heartbeat is received from the detector using a signal processor. One or more subwaveforms within P, Q, R, S, T, U, and J waveforms of the ECG waveform for each heartbeat or in an interval between the P, Q, R, S, T, U, and J waveforms that represent the depolarization or repolarization of an anatomically distinct portion of muscle tissue of the beating heart are detected using the signal processor. A processed ECG waveform that includes the one or more subwaveforms for each heartbeat is produced using the signal processor.

[0136] In step **1630**, the processed ECG waveform is received from the signal processor and the processed ECG waveform is displayed using a display device.

Computer Program Product for Detecting ECG Subwaveforms

[0137] In various embodiments, computer program products include a tangible computer-readable storage medium whose contents include a program with instructions being executed on a processor so as to perform a method for detecting subwaveforms within the P, Q, R, S, T, U, and J waveforms of an ECG waveform of a heartbeat or in an interval between the P, Q, R, S, T, U, and J waveforms. This method is performed by a system that includes one or more distinct software modules.

[0138] FIG. 17 is a schematic diagram of a system **1700** that includes one or more distinct software modules that perform a method for detecting subwaveforms within the P, Q, R, S, T, U, and J waveforms of an ECG waveform of a heartbeat or in an interval between the P, Q, R, S, T, U, and J waveforms, in accordance with various embodiments.

System 1700 includes detection module 1710, processing module 1720, and display module 1730.

[0139] Detection module 1710 detects electrical impulses between at least one pair of electrodes of two or more electrodes placed proximate to a beating heart. Detection module 1710 converts the electrical impulses to an ECG waveform for each heartbeat of the beating heart.

[0140] Processing module 1720 receives the ECG waveform for each heartbeat. Processing module 1720 detects one or more subwaveforms within P, Q, R, S, T, U, and J waveforms of the ECG waveform for each heartbeat or in an interval between the P, Q, R, S, T, U, and J waveforms that represent the depolarization or repolarization of an anatomically distinct portion of muscle tissue of the beating heart. Processing module 1720 produces a processed ECG waveform that includes the one or more subwaveforms for each heartbeat.

[0141] Display module 1730 receives the processed ECG waveform. Display module 1730 displays the processed ECG waveform.

Multi-Domain ECG

[0142] The heart muscle, like other muscles, is activated by biologically generated electrical signals. Electrocardiography (ECG or EKG) has long been used to measure and record these electrical signals. Essentially, in ECG the electrical activity of the heart is measured from a number of different points on the body and plotted over time. As a result, ECG traces out each cardiac cycle or heartbeat as a voltage versus time waveform.

[0143] A human heart has two functional systems. The first system, referred to as a self-conduction system, is part of the atrium (including left and right atria). In a traditional ECG, the self-conduction system is represented by the P wave or PR interval. The excitation, rhythm, and conduction of every beat are completed by the collaboration of all parts of the heart, which is an axis system, including: sinoatrial node (SAN)—atrial—atrioventricular node (AVN)—Bundle of His—Bundle Branches (left and right). The Bundle of His is a collection of heart muscle cells specialized for electrical conduction that transmits the electrical impulses from the AVN to the point of the apex of the fascicular branches. Complex arrhythmias disease typically occurs in these different areas. However, ECG is only half of a sine wave.

[0144] The second system, referred to as a cardiac work system, is a pump system (one for each complete contraction and relaxation of the heart), which is done by the heart muscles. The main part of the second system is the left ventricle. In the traditional ECG, it is represented by the T wave or QT interval. There are about 10 million ventricular myocardial cells, without nerves or tracts.

[0145] Features or waves of each heartbeat waveform have been known for more than a century to correspond to electrical signals activating various parts of the heart. For example, the P wave is known to result from an electrical signal directed from the SAN to the AV node activating the atrium of the heart, to the Bundle of His to the left and right Bundle Branches, and the wave is known to result from a recovery electrical signal (ventricular depolarization and repolarization) sent to the ventricles of the heart after they have contracted. As a result, physicians are able to diagnose specific heart problems by analyzing the shapes and time of these waves.

[0146] It is thought that an ECG heartbeat waveform includes much more information about the anatomy of the heart that is not being used (scanning and displaying). In particular, it is thought that at least some of the waves in an ECG heartbeat waveform include subwaveforms that provide more detailed information about parts of the heart, as described above. Consequently, there is a need for systems and methods for processing biological electrical signals, such as signals read by ECG, in order to provide additional information about anatomical structures.

[0147] Also, electrocardiogram information itself contains a lot of information that has not been discovered so far, leaving numerous puzzles in a clinical application.

[0148] In various embodiments, new waveforms are created from a conventional ECG waveform. New indexes and new parameters are obtained from the new waveforms, so that it is possible to have a breakthrough in electrocardiogram diagnostics.

[0149] In various embodiments, heart signals are divided into different frequency bands, and then convolved or combined in one diagram. For example, 16 different frequency bands can be used. This procedure is based on the study of ergonomics and analysis procedures for frequently used information in cybernetics and nonlinear theory. The procedure makes use of the theory and analysis index of an “electrocardiogram multi-phase signal,” and by using a new method of frequency division and dimension division, according to the display method of P, Q, R, S, T, U, and J waveforms P-QRS-T in a conventional ECG waveform. Heart diseases are also related to and/or complicated by different other diseases. Therefore, different numbers of frequency ranges are required to be displayed as a diagnostic requirement, because the frequency shifts of various diseases are different. In the multi-domain frequency division method, 8, 9, 10, 11, 12, 13, 14, 15, or 16 roots of multi-domain linear waveforms are displayed, and a total of 12 leads are individually displayed. If each lead is divided into 16 waveforms, there are totally 192 ECG waveforms, providing much more information. In various embodiments, multi-domain ECG (mdECG) can be used as a very valuable and new diagnostic technique for combined heart diseases. This technique can be applied in electrocardiograph, monitor, echocardiography, and invasive electrophysiological instrument.

[0150] Since the invention of ECG, the linear waveform shaped like a rope has been used. Its frequency response range is 0-150 Hz and all subwaveforms are convolved or combined together. However, heart signals are formed by combining different ultra-low frequency, low frequency, intermediate frequency, high frequency, and ultra-high frequency signals. Because in ECG all frequencies are convolved together, many fine, weak, and very valuable signals are usually submerged or overlapped by the high frequency; especially at ventricle (ECG at T-wave, ECG ‘T’ wave duration) and atrium (ECG at P-wave, ECG ‘P’ wave duration), and numerous signals accumulate within a very small time axis range, causing problems and confusion in the accuracy of the ECG diagnosis rate. As a result, the detection rate of ECG for acute myocardial infarction (AMI), acute coronary syndrome (ACS), coronary artery disease (CAD), myocardial infarction (MI), heart failure (HF), etc., with the highest incidence of cardiovascular disease is only 17%-25%. Based on a large number of research reports, for the CAD/MI/ACS patient, ECG begins to change only after

ischemia reaches 70%, and only about half of the electrocardiograms show abnormality. There are 7 billion people in the world, and the percentage of people who die of cardiovascular diseases or complicated cardiovascular diseases is about 42.86% ($\frac{3}{7}$). An electrocardiogram is the most fundamental clinical assessment instrument, and it is simple, fast and economical. Therefore, it is important to improve the clinical ECG diagnosis rate, which is possible only by improving the waveform display rate of ECG.

[0151] In various embodiments, systems and methods improve the waveform display rate of ECG and clinical diagnosis rate using a 16 linear multi-domain electrocardiogram. Because the heart signals are separated according to different frequency bands with frequency bands being recombined, many high frequency signals, ultra-high frequency signal, low frequency signals, and ultra-low frequency signals are displayed with the raw heart signals at different frequency band according to the heart transduction pathway and electrophysiological rule, without the electrocardiogram being altered, i.e., at X-transverse axis and Y-vertical axis of P-QRS-T. Because the frequency bands of ECG are combined signals, mdECG separates the signals, i.e., separates them into independent waveforms consisting of different frequency bands. In this way, those frequency bands with the one linear waveform invisible and obscure in traditional ECG can be displayed clearly with different frequency bands one by one, assisting the doctor in reading, analyzing, judging and basic clinical assessment.

[0152] FIG. 18 is an exemplary block diagram 1800 showing a system for performing multi-domain ECG using 16 different frequency bands or domains, in accordance with various embodiments. Sampling block 1810 samples the electrical impulses at one electrode for one heartbeat, for example. This is shown graphically in FIG. 1800 by converting ECG waveform 200 to sampled ECG waveform 1820 using block 1810. The electrical impulses for the entire ECG waveform 200 are sampled using electrodes 810 and detector 820 of FIG. 8, for example. Detector 820 of FIG. 8 can also amplify and convert the analog signal into a digital signal for digital processing.

[0153] The signal processing can be performed directly on the time domain signal received from a detector or the time domain signal received from a detector can be converted to the frequency domain for algorithmic processing. In FIG. 18, block 1830 converts sampled ECG waveform 1820 to a frequency domain signal. The time domain signal is converted into a frequency domain signal using a Fourier transform, for example.

[0154] As described above, through animal and/or human experimentation, the frequency bands associated with different muscles of the heart can be determined. The frequency bands used here can be based on those bands determined experimentally, for example. Alternatively, the 16 frequency bands can be found by dividing the total frequency bands 16 ways. The different band can have the same bandwidth or can have different bandwidths.

[0155] In block 1840, 16 different band pass filters filter sampled ECG waveform 1820's frequency domain signal into 16 different frequency domain signal. These 16 different 16 different frequency domain signals are then converted back to the time domain. The result of block 1840 is 16 different time domain signals.

[0156] In block 1850, the 16 different time domain signals are combined or plotted together in the time domain as one

multi-domain ECG waveform 1860. In FIG. 1800, a conventional ECG signal from one electrode is processed into a multi-domain ECG waveform that includes 16 different time domain signals. In various embodiments, a conventional ECG signal from one electrode, however, can be processed into a multi-domain ECG waveform that includes any number of different time domain signals.

[0157] FIG. 19 is an exemplary plot 1900 of a multi-domain ECG waveform that includes 10 different time domain signals, in accordance with various embodiments.

[0158] FIG. 20 is an exemplary plot 2000 of a multi-domain ECG waveform that includes 14 different time domain signals, in accordance with various embodiments.

[0159] FIG. 21 is an exemplary alignment 2100 of a multi-domain ECG waveform 2110 that includes 16 different time domain signals with a conventional ECG waveform 2120, in accordance with various embodiments. Multi-domain ECG waveform 2110 is produced from conventional ECG waveform 2120 using the system depicted in FIG. 18, for example. As shown in FIG. 21, multi-domain ECG waveform 2110 can display data with negative values while conventional ECG waveform 2120 cannot.

[0160] Systems and methods for detecting multi-domain ECG waveforms are described in the '930 Patent, which is incorporated by reference in its entirety.

Example Saah ECG Waveforms and EPCG Waveforms

[0161] FIG. 29 is an exemplary diagram 2900 of the anatomy of the self-conducting system of a heart, in accordance with various embodiments. The self-conducting system begins with S-A node (SAN) 2910. Conduction moves from SAN 2910 through transitional fibers 2920 to A-V node (AVN) 2930. Conduction then moves from AVN 2930 past atrioventricular fibrous tissue 2940 and through penetrating portion of A-V bundle (His bundle) 2950 to distal portion of A-V bundle 2960. From distal portion of A-V bundle 2960 conduction moves through right bundle branch 2971 and left bundle branch 2972 to ventricular septum 2960.

[0162] FIG. 30 is an exemplary diagram 3000 showing the anatomic sites that the PA, AH, and HV intervals represent and the corresponding PA, AH, and HV intervals in a saah ECG waveform and traditional ECG waveform, in accordance with various embodiments. PA interval 3011, AH interval 3012, and HV interval 3013 are depicted with respect to anatomic sites along self-conducting system 3020 of the heart. The same intervals, PA interval 3011, AH interval 3012, and HV interval 3013, are also shown with respect to saah ECG waveform 3030 and traditional ECG waveform 3040. FIG. 30 shows that processed or calculated information like PA interval 3011, AH interval 3012, HV interval 3013, and saah ECG waveform 3030 relate ECG signals more closely to the anatomy of self-conducting system 3020 than traditional ECG waveform 3040.

[0163] FIG. 31 is an exemplary comparison plot 3100 of a saah ECG waveform and a traditional ECG waveform with PA, AH, HV, and PR interval values obtained from aiECG processing for a patient with a normal heart, in accordance with various embodiments. Timing values for PA interval 3111, AH interval 3112, HV interval 3113 and PR interval 3114 are shown with respect to saah ECG waveform 3130 and aligned traditional ECG waveform 3140. As described above, PR interval 3114 refers to the time period that includes the P waveform and the PR segment of traditional ECG waveform 3140. FIG. 31 shows that processed or

calculated information like the timing values for PA interval **3111**, AH interval **3112**, HV interval **3113**, and PR interval **3113** and saah ECG waveform **3130** provide much more information than traditional ECG waveform **3140** on its own.

[0164] FIG. **32** is an exemplary comparison plot **3200** of a portion of a multi-domain ECG or electrophysiocardiogram (EPCG) waveform aligned with a portion of a traditional ECG waveforms for a patient with acute coronary syndrome (ACS) before and after percutaneous coronary intervention (PCI), in accordance with various embodiments. EPCG waveform **3210** is aligned with traditional ECG waveform **3220** for the patient with ACS before PCI treatment. EPCG waveform **3211** is aligned with traditional ECG waveform **3221** for the patient with ACS after PCI treatment. A comparison of magnified portions **3230** and **3231** of EPCG waveforms **3211** and **3211**, respectively, shows that all small waveforms are not apparent in waveform portion **3210** before PCI treatment are back to normal after PCI treatment in waveform portion **3211**. Similar information cannot be found in a comparison of traditional ECG waveforms **3220** and **3221**.

[0165] FIG. **33** is an exemplary diagram **3300** showing timing values of conduction calculated at various anatomic sites along the self-conduction system of a normal heart by further processing a traditional ECG waveform, in accordance with various embodiments. For example, timing values are provided for the atrial myocardium (AM) **3310**, the sino atrial node (SAN) **3320**, the atrioventricular node (AVN) **3330**, Purkinje's cell (PC) **3340**, and the ventricular myocardium (VM) **3350**. The right ventricle (RV) **3360** and the left ventricle (LV) **3370** are also labeled in diagram **3300**.

Automated ECG Analysis and Diagnosis

[0166] As described above, to date the accuracy rate of automated ECG analysis and diagnosis systems has been a problem in clinical applications. There are at least three technical reasons for this. 1. The conventional ECG waveform is morphological and generally no consistent mapping points can be found. 2. Conventional ECG measurements have not provided information specific different parts of the heart muscle. 3. Automated ECG waveform analysis has generally resulted in a high number of false positives for both normal and abnormal populations. However, ECG remains one of the most extensively used clinical tools, despite the lack of accurate systems for automated ECG analysis and diagnosis. As a result, there is a significant need for such systems. Recent advancements have addressed the conventional ECG waveform measurement problem. Specifically, the systems of the '204 Patent the '930 Patent have allowed the different frequency domain signals from different parts of the heart muscle to be measured.

[0167] Additional systems, however, are needed to further address the technical problems of analyzing the shape and form of these frequency domain signals and distinguishing disease conditions from false positives in normal and abnormal populations.

Conventional ECG Waveform Analysis Problems

[0168] Analysis of conventional ECG waveforms for clinical diagnosis has been limited by a number of problems for more than a century. (1) It has been difficult to correctly confirm the start point of the P wave. The reason for this is

that the start point of the P wave is on "a parallel equipotential line," which needs to be determined. This has traditionally been determined through guessing. If the starting point of each heartbeat cannot be correctly identified, then all subsequent parameter measurements will be wrong. The normal value for the conduction time from the SA node (the starting point of the P wave) to the atrium is only around 30 ms. As a result, a small mistake in the location of the starting point can make a big difference in the measurement of this conduction time.

[0169] FIG. **14** is an exemplary plot **1400** of a conventional ECG waveform showing how a small error in the starting point of the P wave can cause a large error in all subsequent time measurements, in accordance with various embodiments. The starting point of P wave **1430** of conventional ECG waveform **1410** is somewhere on parallel equipotential line **1420**. Each square of the grid of plot **1400** represents a time of 40 milliseconds (ms). Parallel equipotential line **1420** spans about one square of the grid of plot **1400**. As a result, picking four different closely spaced points along parallel equipotential line **1420** produces starting point times that vary among 8 ms, 16 ms, 24 ms, and 32 ms within the one square of the grid of plot **1400**. In other words, small differences in the selection of the starting point of P wave **1430** can mean large differences in the timing values used for P wave **1430**. It can also affect all of the other components of ECG waveform **1410**. This is because the starting point of P wave **1430** is also the starting point of the entire ECG waveform **1410**.

[0170] (2) At the PR interval, it has been difficult to identify the specific PA, AH, or HV intervals within PR interval. When the PR interval is abnormal, in particular, it can only be estimated and cannot be measured. Also, often the end of the PR interval cannot be confirmed, as there is no equipotential and the starting point of QRS wave appears to be an upward arc angle.

[0171] FIG. **15** is an exemplary plot **1500** of a conventional ECG waveform showing how the end of the PR interval cannot be confirmed due to an upward arc angle of the starting point of QRS wave, in accordance with various embodiments. The timing measurement of PR interval **1520** of conventional ECG waveform **1510** is a very important measurement since it the only measurement for the atrium. As described above, it is difficult to measure the starting point of the P wave, which is also the start of PR interval **1520**. It turns out it is just as difficult if not more difficult to measure the ending point of PR interval **1520**. This is due to changes to parallel equipotential line **1530** at the ending point of PR interval **1520** as shown in plot **1500**. Parallel equipotential line **1530** is not parallel at all but rather is shaped like an upward arc angle. Therefore, it is very difficult to accurately map PR interval **1520**. The standard value for PR interval **1520** is 120-200 ms, for example. In contrast, PR segment **220** of ideal conventional ECG waveform of FIG. **2** has a parallel equipotential line just before a downward arc angle to the QRS wave.

[0172] (3) It has been difficult to identify a difference between the ST segment of a normal person and the ST segment of an abnormal person. In other words, the ST segment appears to be exactly abnormal for normal people and exactly normal for abnormal people. Also, and the J point often disappears, making it impossible to determine. As a result, the standards for the ST segment often cannot be applied.

[0173] FIG. 22 is an exemplary plot 2200 of a conventional ECG waveform showing how the ST segment of a normal person can appear abnormal, in accordance with various embodiments. Plot 2200 shows the conventional ECG waveform 2210 of a normal person. However, ST segment 2220 has lifted or arc shape. As a result, ST segment 2220 is difficult to measure. The normal morphological waveform is exactly like abnormal, while abnormal is exactly like normal.

[0174] (4) It has been difficult to identify the main peak of the T wave. Often it appears to be exactly abnormal (inverted) for normal people and exactly normal for abnormal people, making it almost impossible to determine.

[0175] FIG. 23 is an exemplary plot 2300 of a conventional ECG waveform showing how the T wave of an abnormal person can appear normal, in accordance with various embodiments. Plot 2300 shows the conventional ECG waveform 2310 of an abnormal person. However, the T wave 2320 appears normal.

[0176] (5) It has been difficult to identify which section of an autonomic conduction system is blocked.

[0177] FIG. 24 is an exemplary plot 2400 of a conventional ECG waveform showing how the section of an autonomic conduction system cannot be determined from a conduction block, in accordance with various embodiments. In plot 2400, conduction in the PR interval 2420 of conventional ECG waveform 2410 is blocked. However, from conventional ECG waveform 2410 it is impossible to tell how the signal was conducted down through the conduction system.

[0178] (6) It has been difficult to identify the section of an autonomic conduction system that causes a QRS complex to widen or narrow.

[0179] FIG. 25 is an exemplary plot 2500 of a conventional ECG waveform showing how the QRS complex is widened in the waveform, in accordance with various embodiments. In plot 2500, although QRS complex 2520 is widened in conventional ECG waveform 2510, it is not possible to determine if this is caused by the atrium or the ventricle.

[0180] (7) It has been difficult to identify atrial anatomical positions, such as SA node, AV node, Bundle of His, and Purkinje's, from a conventional ECG waveform, as described above.

[0181] FIG. 26 is an exemplary plot 2600 of a conventional ECG waveform showing how the atrial anatomical positions are difficult to identify, in accordance with various embodiments. In plot 2600, the entire PR interval 2620 of conventional ECG waveform 2610 is abnormal and cannot be measured. A calibration point cannot be mapped. For the patient in this case, the elevated ST segment also cannot be measured. Clinically, an elevated ST segment is also often measured for normal people.

[0182] (8) It has been difficult to identify when a premature ventricular beat occurs. It is almost impossible to determine the position of an ectopic premature beat, especially when the premature ventricular beat is accompanied with an aberrant conduction.

[0183] FIG. 27 is an exemplary plot 2700 of a conventional ECG waveform showing a premature ventricular beat, in accordance with various embodiments. In plot. In plot 2700, conventional ECG waveform 2710 includes premature ventricular beat 2720. When premature ventricular beat 2720 occurs, it is not possible to determine whether it is

benign or malignant. Not all premature ventricular beats are malignant. In general, a conventional ECG waveform can only show that a premature ventricular beat or premature atrial contraction has occurred.

[0184] (9) It has been difficult to identify a malignant arrhythmia.

[0185] FIG. 28 is an exemplary plot 2800 of a conventional ECG waveform showing in atrial conduction block, in accordance with various embodiments. In plot 2800, conventional ECG waveform 2810 includes conduction block 2820. However, it is not possible to determine the specific block location of conduction block 2820. The position can determine whether or not the block is malignant. For example, if it is below the His bundle, the block is malignant.

[0186] In summary, at an abnormal moment, signals of a conventional ECG waveform often shift positions, and the waveform is changed to a different shape, making it difficult or impossible to estimate. If a conventional ECG waveform is changed in such a way and human intelligence or experience is still relied on to diagnose, a large amount of accuracy is lost.

Automated ECG Analysis and Diagnosis using AI

[0187] As described above, additional systems are needed to further address the technical problems of analyzing the shape and form of the frequency domain signals of a conventional ECG waveform and distinguishing disease conditions from false positives in normal and abnormal populations using the conventional ECG waveform.

[0188] In various embodiments, these technical problems are addressed by 1. applying artificial intelligence (AI) algorithms to characterize the shape and form of the frequency domain signals of a conventional ECG waveform; 2. comparing the characterized shape and form of the frequency domain signals to a database of characterized signals from normal and abnormal populations using human like AI algorithms and non-human like AI algorithms; and 3. annotating the conventional ECG waveform with diagnosis information based on the comparison.

[0189] FIG. 34 is an exemplary block diagram 3400 of a system for automated ECG analysis and diagnosis using AI, in accordance with various embodiments. In step 3401 of the system of FIG. 34, two or more electrodes are attached to the skin of a patient to obtain electrical signals from the heart muscle. In various alternative embodiments, the two or more electrodes may be attached directly and invasively to the heart muscle. The two or more electrodes are, for example, conventional ECG leads.

[0190] In step 3402, electrical heart signals are obtained from the two or more electrodes.

[0191] In step 3403, the electrical heart signals are detected and amplified.

[0192] In step 3404, the amplified signals are processed. For example, the signals from a number of different conventional ECG leads are combined.

[0193] In step 3405, the combined signals form a conventional ECG waveform.

[0194] In step 3406, the conventional ECG waveform is displayed or printed, for example.

[0195] In step 3410, the detected signals of step 3403 are obtained and processed to produce two or more frequency domain signals.

[0196] In step 3411, the two or more frequency domain signals are processed for characteristics of cardiac electrophysiological signals using one or more AI algorithms.

[0197] In step 3412, the cardiac electrophysiological characteristics of the two or more frequency domain signals are compared to databases of similar cardiac electrophysiological characteristics for normal and abnormal populations using the system of FIG. 34.

[0198] In step 3420, the cardiac electrophysiological characteristics of the two or more frequency domain signals are compared to the databases using human like AI algorithms. These human like AI algorithms can include, but are not limited to, an expert and cardiologist system 3421, an ECG diagnosis system 3422, an intelligent signals unsupervised feature learning system 3423, a general ECG problem solver 3424, and a semantic ECG waveform system 3425.

[0199] In step 3430, the cardiac electrophysiological characteristics of the two or more frequency domain signals are compared to the databases using non-human like AI algorithms. These human like AI algorithms can include, but are not limited to, a neural network algorithm 3431 and a deep learning algorithm 3432. The neural network algorithm 3431 can include a shallow network 3433. The deep learning algorithm 3432 can include a deep network 3434. This deep network 3434 can include, but is not limited to, a convolution all neural network (CNN) 3435, a deep belief net (DBN) 3436, or a restricted Boltzmann machine (RBM).

[0200] In step 3440, the results from steps 3420 and 3430 are combined to provide diagnosis information for the conventional ECG waveform.

[0201] In step 3406, this diagnosis information is displayed on the conventional ECG waveform.

[0202] The system of FIG. 34 provides a number of advantages over conventional automated analysis and diagnosis systems. First of all, it reduces medical and insurance expenses. As a result of the automated diagnosis information patients can avoid invasive and expensive examinations. Secondly, the quick and accurate diagnosis information allows prompt and accurate treatment. In other words, the shortened time for diagnosis allows treatment to occur without delay. Thirdly, the quick and accurate diagnosis helps train doctors more efficiently and can significantly reduce misdiagnosis rates. Fourthly, the quick and accurate diagnosis information can help in the research and development of new target drugs for cardiac treatments. Finally, the use of these AI algorithms in ECG makes these instruments intelligent systems.

[0203] In various embodiments, the diagnosis information presented in step 3406 can include, but is not limited to, diagnosis markers or more accurate timing information.

Automated Diagnosis Markers and Timing Information

[0204] FIG. 35 is an exemplary plot 3500 of a conventional ECG waveform annotated with diagnosis marker information, in accordance with various embodiments. In plot 3500, conventional ECG waveform 3501 is annotated with five different diagnosis markers or prompts. Unfilled arrow marker 3510 represents a specific conduction block position. Unfilled diamond marker 3520 represents a hidden P wave. Unfilled triangle marker 3530 represents a premature ventricular beat position. Unfilled pentagon marker 3540 represents a position where a heartbeat is not conducted. Filled arrow marker 3550 represents a normal heartbeat.

[0205] FIG. 36 is an exemplary comparison 3600 of timing information from a conventional ECG waveform and from an ECG waveform produced and annotated using an automated analysis and diagnosis system, in accordance with various embodiments. Comparison 3600 includes timing information from conventional ECG waveform 3610 and timing information from ECG waveform 3620 produced and annotated using an automated analysis and diagnosis system.

[0206] Conventional ECG waveform 3610 measures first AH interval 3611 to be 102 ms and second AH interval 3612 to be 105 ms. In contrast, annotated ECG waveform 3620 measures first AH interval 3621 to be 105 ms and second AH interval 3622 to be 106 ms.

[0207] Similarly, conventional ECG waveform 3610 measures first HV interval 3613 to be 50 ms and second HV interval 3612 to be 47 ms. In contrast, annotated ECG waveform 3620 measures first HV interval 3623 to be 53 ms and second HV interval 3624 to be 49 ms.

[0208] Comparison 3600 shows that an automated analysis and diagnosis system can produce more accurate timing information than a conventional ECG system.

System for Identifying and Annotating Cardiac Electrophysiological Signals

[0209] The conventional ECG's P-QRS-T waveform records the normal atrial and ventricular muscles, which is composed of high frequency (HF), ultra high frequency (UHF), and super high frequency (SHF) signals. The heart is a micro-current organ. The atrium has two electrical channels, while the ventricle has multilayer channels. In conventional ECG systems the majority of the high frequency signals of the ECG waveform are convoluted with other signals. Besides the normal atrial muscle, there also exists a special conduction system. In addition to the normal Ventricular muscle, there are multilayer characteristic cellular groups. These specific signals are not accurately displayed in the conventional ECG P and T waves. This is the reason why the conventional ECG waveform has not evolved and has been difficult to change.

[0210] The reason why the conventional ECG waveform has not evolved is related to the developmental history of mathematics. Since its invention, ECG has only had an empirical formula, which is basically a guide, such as: III lead link is equal to II lead minus I lead. However, no mathematical formula proof for this formula exists. Calvani founded electrophysiology in 1791. Matteucci discovered heart electrical activity in 1842. In 1898, Waller proposed the electrocardiogram dipole distribution theory, in 1912 recorded the electrical waveform by electrocardiogram, and named this sinusoidal line the P-QRS-T. A conventional ECG system scans and records this sinusoidal wave.

Harmonics and Discontinuities

[0211] Since as early as the 17th century, however, there has been a huge controversy in the scientific-mathematical world. In the academic world, an argument arose between Fourier and Lagrange, which focused on whether the sine wave curve contained minute, harmonic frequency signals. It wasn't until 1898 (ECG theory proposed the same year) that Nobel Prize winner Albert Abraham Michelson successfully developed the harmonic analyzer. Using this method, the American mathematical physicist Josiah Willard

Gibbs confirmed that a sinusoidal wave can contain a harmonic image, which was later called the Gibbs phenomenon. The pioneers of the traditional ECG did not mean to discover this confirmation of a great theory of mathematics and, until this day, this discovery has not been taken seriously. Harmonics are cycles, The signal can be the sum of many sine waves because the frequency of the ECG sine wave is different, and there are harmonic (wavelet or sub-waveforms) signals between and within the P-QRS-T waveforms. For more than a century, scientists have been studying the ECG waveform, ignoring basic signal processing (mathematics) and ignoring the fact that sine waves are convolutions of multitudes of discontinuities.

[0212] In various embodiments, a complete set of signal processing systems have been developed to measure these subwaveforms and discontinuities. For example, the visual EPCG waveform has been confirmed within the P-QRS-T waveform. It contains many small subwaveforms (harmonics). These are located in the conventional ECG waveform in front of the P wave, in the P wave itself, after the P wave, to the right and left side of the QRS, in the ST segment, in the T wave, and after the T wave, for example. In other words, it has been confirmed that the conventional ECG periodic signal is composed of the sum of its harmonics.

ST Segment Harmonics and Discontinuity Points

[0213] Most recently and in various embodiments, new subwaveforms and discontinuity points have been discovered in relation to the ST segment. Exemplary ST segment 260 is shown in FIG. 2, for example. The ST segment is one of the least understood elements of a conventional ECG waveform.

[0214] FIG. 39 is an exemplary ECG waveform plot 3900 showing the relative positions of the PR and ST segments for a normal heartbeat, in accordance with various embodiments. In plot 3900, PR segment 3910 and ST segment 3920 have the same position vertically.

[0215] Conventionally, there is only one standard for accessing the ST segment: either elevation or descent.

[0216] FIG. 40 is an exemplary ECG waveform plot 4000 showing how the ST segment can shift vertically due to abnormal conditions, in accordance with various embodiments. In plot 4000, ST segment 4020 can elevate or descend vertically depending on the abnormal condition. This standard or rule can be referred to as STy.

[0217] According to the STy standard, one or more (mV) movements upward from the baseline x-axis (isoelectric line) equate to an elevation. Similarly, one or more mV movements downward from the baseline x-axis equate to descent or depression. The problem with this ST segment standard, is that 90% of normal data for healthy people usually shows an ST segment elevation. In addition, abnormal data for unhealthy people is usually not represented as a simple elevation or a descent.

[0218] FIG. 41 is an exemplary ECG waveform plot 4100 showing how the ST segment can be deformed due to abnormal conditions, in accordance with various embodiments. In plot 4100, ST segment 4120 can be deformed so that it forms a concavity or convexity vertically, for example.

[0219] FIG. 42 is an exemplary ECG waveform plot 4200 showing how the vertical or horizontal movement of the end of the RS segment can affect the ST segment due to abnormal conditions, in accordance with various embodi-

ments. In plot 4200, the movement of end 4230 of RS segment removes the difference between the S point and J point of ST segment 4220, for example.

[0220] FIG. 43 is an exemplary ECG waveform plot 4300 showing how the ST segment can shift horizontally due to abnormal conditions, in accordance with various embodiments. In plot 4300, the length of ST segment 4320 can shorten or widen horizontally depending on the abnormal condition.

[0221] FIG. 44 is an exemplary ECG waveform plot 4400 showing how vertical or horizontal movement of the J point can affect the ST segment due to abnormal conditions, in accordance with various embodiments. In plot 4400, the movement of J point 4440 can change the length or slope of ST segment 4420, for example.

[0222] In various embodiments, new standards or rules are developed to assess the ST segment based on harmonic waveforms and points of discontinuity. These standards or rules are used in AI algorithms, for example.

[0223] In one embodiment, an STx standard is developed. A conventional ECG system cannot measure the sum of the ST segment and the T segment (x-axis time parameter). The STx standard measures the sum of the ST segment and the T segment. This sum is typically <380 ms. This STx standard is extremely important and can be compared to the borderlines between countries. represents time value changes. The following are times changes which can occur. (1) The time value change may be >100 ms. (2) The time value change may be <40 ms. (3) The time value change may be =0 ms. (4) The ST-T segment may also be represented as a negative curve (lower than the isoelectric line). (5) These time changes are all based on relation to the x-axis.

[0224] In another embodiment, an STa standard is developed. The "a" relates to amplitude. (1) The top peak of the T wave may be lower than the P wave's top peak, or the two waves are equal. (2) The starting point of the P wave is greater than the isoelectric line. (3) T wave terminal point is greater than the isoelectric line. (4) The T wave's time value is less than P wave's time value (reversed). All of these changes will cause the ST segment to deform.

[0225] In another embodiment, an STs standard is developed. The "s" relates to the slope. This is only related to the terminal slope of the ST segment in relation to the initial slope of the T wave. The following are new pattern recognition rules. (1) This slope shrinks or shortens. (2) This slope is represented as the isoelectric line. (3) This slope is lower than the isoelectric line. (4) The ST slope is upside-down, but the T wave is normal. (5) This slope takes on an upward slope but looks convex instead of the traditional concave slope. (6) The ST segment slope completely disappears, and the T wave begins directly after the QRS segment (this happens very often). (7) The ST segment is completely horizontal with the isoelectric line; the two halves of the T wave are complete mirrors of each other in both angle and slope.

[0226] In another embodiment, an STj standard is developed. The "j" relates to the J-point. (1) The S point to the J-point time is increased. (2) S-point and J-point disappear; there is almost a 90° angle between the RS end and ST segment start. (3) The S-point and J-point are concealed within the RS segment; the J-point is above the isoelectric line. (4) The J-point falls below the isoelectric point, concealed deep into RS.

[0227] FIG. 45 is an exemplary comparison 4500 of two ECG waveform plots exhibiting ST segment changes that can be identified using the STy standard, in accordance with various embodiments. In plot 4510, the ST segment is identified as elevating according to the STy standard. In plot 4520, the ST segment is identified as descending according to the STy standard.

[0228] FIG. 46 is an exemplary comparison 4600 of two ECG waveform plots exhibiting ST segment changes that can be identified using the STx standard, in accordance with various embodiments. In plot 4610, the ST segment is identified as widened according to the STx standard. In plot 4620, the ST segment is identified as shortened according to the STx standard.

[0229] FIG. 47 is an exemplary comparison 4700 of two ECG waveform plots exhibiting ST segment changes that can be identified using the STs and STy standards (STs±STy), in accordance with various embodiments. In plot 4710, the ST segment is identified as a down-sloping depression according to the STs and STy standards (STs+STy). In plot 4720, the ST segment is identified as an up-sloping depression according to the STs and STy standards (STs+STy).

[0230] FIG. 48 is an exemplary comparison 4800 of two ECG waveform plots exhibiting ST segment changes that can be identified using the STy, and STx standards (STj+STy+STx), in accordance with various embodiments. In plot 4810, the ST segment is identified as a depression according to the STj, STy, and STx standards (STj+STy+STx). In plot 4820, the ST segment is identified as vanishing according to the STj, STy, and STx standards (STj+STy+STx)the STs and STy standards (STs+STy).

[0231] FIG. 49 is an exemplary ECG waveform plot 4900 of an ST segment change that can be identified using the STx and STj standards (STx+STj), in accordance with various embodiments. In plot 4900, the ST segment is identified as having a widened RJ interval according to the STx and STj standards (STx+STj).

Analysis and Diagnosis System

[0232] The systems of the '204 Patent the '930 Patent have used different signal processing methods to detect the harmonic signals and discontinuity points of a conventional ECG waveform. In various embodiments, artificial intelligence (AI) in conjunction with a database of normal and abnormal ECG data is used to detect the harmonic signals and discontinuity points of a conventional ECG waveform and to annotate cardiac electrophysiological signals in the ECG waveform as normal or abnormal.

[0233] FIG. 37 is a block diagram 3700 of an ECG system for identifying and annotating cardiac electrophysiological signals in an ECG waveform as normal or abnormal during measurement of the ECG waveform, in accordance with various embodiments. Electrodes 3710 are attached to the skin of a patient in a noninvasive measurement, for example. In an alternative embodiment, electrodes 3710 are attached directly on the surface of a beating heart of a patient. Electrical signals produced by a beating heart are detected between pairs of electrodes 3710.

[0234] A voltage signal is detected between two electrodes 3710 by detector 3720. Detector 3720 also amplifies the voltage signal. Detector 3720 converts the electrical impulses to an ECG waveform for each heartbeat of the beating heart. Detector 3720 converts the voltage signal to

a digital voltage signal using an analog to digital converter (A/D), for example. Detector 3720 provides the detected and amplified voltage signal from each pair of electrodes 3710 directly to display device 3740 to display the ECG waveform. The ECG waveform includes conventional P, Q, R, S, T, U, and J waveforms, for example. Detector 3720 also provides the detected and amplified voltage signal from each pair of electrodes 3710 directly to processor 3730.

[0235] Processor 3730 can be a separate electronic device that can include, but is not limited to, an application specific integrated circuit (ASIC), a field programmable gate array (FPGA), or a general purpose processor or computer, such as the system of FIG. 1. Processor 3730 can be software implemented on another processor of the ECG device, such as a processor of display device 3740. Processor 3730 can also include a remote server computer.

[0236] Processor 3730 receives the ECG waveform for at least one heartbeat from detector 3720. Processor 3730 converts the ECG waveform to a frequency domain waveform. Processor 3730 separates the frequency domain waveform into two or more different frequency domain waveforms. Processor 3730 converts the two or more different frequency domain waveforms into a plurality of time domain cardiac electrophysiological subwaveforms and discontinuity points between these subwaveforms of the ECG waveform.

[0237] Processor 3730 compares the plurality of subwaveforms and discontinuity points to a database (not shown) of subwaveforms and discontinuity points for cardiac electrophysiological signals of ECG waveforms for a plurality of known and normal and abnormal patients. Processor 3730 identifies at least one subwaveform or one or more discontinuity points of the plurality of subwaveforms and discontinuity points as a normal or abnormal electrophysiological signal of the ECG waveform based on the comparison.

[0238] Display device 3740 an electronic display device, a printer, or any combination of the two. Display device 3740 displays the ECG waveform for the at least one heartbeat of the beating heart. Display device 3740 also displays one or more markers at the location of the at least one subwaveform or the one or more discontinuity points on the ECG waveform and identifies the one or more markers as a normal or abnormal cardiac electrophysiological signal. For example, FIGS. 35 and 36 show how one or more markers are displayed on ECG waveforms to indicate normal or abnormal cardiac electrophysiological signals. The one or more markers can be identified as a normal or abnormal cardiac electrophysiological signal using symbols, colors, or text, for example.

[0239] In various embodiments, processor 3730 converts the ECG waveform to a frequency domain waveform, separates the frequency domain waveform into two or more different frequency domain waveforms, and converts the two or more different frequency domain waveforms into a plurality of time domain cardiac electrophysiological subwaveforms and discontinuity points using an artificial intelligence algorithm. The artificial intelligence algorithm includes a multivariable calculus algorithm, for example.

[0240] In various embodiments, processor 3730 compares the plurality of subwaveforms and discontinuity points to a database of subwaveforms and discontinuity points using a human like artificial intelligence algorithm.

[0241] In various embodiments, the human like artificial intelligence algorithm includes an expert and cardiologist

system. This system evaluates the comparison based on morphological rules developed from cardiologists. In other words, the shape differences are compared using rules based on pattern recognition and doctors' experiences.

[0242] In various embodiments, the human like artificial intelligence algorithm includes an ECG diagnosis system. This system evaluates the comparison based on morphological patterns and their correlation to specific diseases.

[0243] In various embodiments, the human like artificial intelligence algorithm includes an intelligent signals unsupervised feature learning system. This system evaluates the comparison based on morphological patterns learned over time by the system.

[0244] In various embodiments, the human like artificial intelligence algorithm includes a general ECG problem solver. This system evaluates the comparison based on one or more known conditions or conflicting conditions including, but not limited to, heart failure (HF), atrium fibrillation (AF), atrial conductor block, premature atrial contraction (PAC), premature ventricular contraction (PVC), atrial tachycardia, and ventricular tachycardia.

[0245] In various embodiments, the human like artificial intelligence algorithm includes a semantic ECG waveform system. This system evaluates the comparison based on additional signal processing rather than pattern recognition.

[0246] In various embodiments, processor 3730 compares the plurality of subwaveforms and discontinuity points to a database of subwaveforms and discontinuity points using a non-human like artificial intelligence algorithm.

[0247] In various embodiments, the human like artificial intelligence algorithm includes a neural network. The neural network can be a shallow network, for example.

[0248] In various embodiments, the human like artificial intelligence algorithm includes a deep learning algorithm. The deep learning algorithm can include a deep network, for example. The deep network can include, but is not limited to, convolution all neural network (CNN), a deep belief net (DBN), or a restricted Boltzmann machine (RBM).

Method for Identifying and Annotating Cardiac Electrophysiological Signals

[0249] FIG. 38 is a flowchart showing a method 3800 for identifying and annotating cardiac electrophysiological signals in an ECG waveform as normal or abnormal during measurement of the ECG waveform, in accordance with various embodiments.

[0250] In step 3810 of method 3800, electrical impulses are received from a beating heart using two or more electrodes.

[0251] In step 3820, the electrical impulses are detected from at least one pair of electrodes of the two or more electrodes and converted to an ECG waveform for each heartbeat of the beating heart using a detector.

[0252] In step 3830, the ECG waveform for at least one heartbeat is received from the detector, the ECG waveform is converted to a frequency domain waveform, the frequency domain waveform is separated into two or more different frequency domain waveforms, and the two or more different frequency domain waveforms are converted into a plurality of time domain cardiac electrophysiological subwaveforms and discontinuity points between these subwaveforms of the ECG waveform using a processor.

[0253] In step 3840, the plurality of subwaveforms and discontinuity points are compared to a database of subwave-

forms and discontinuity points for cardiac electrophysiological signals of ECG waveforms for a plurality of known and normal and abnormal patients using the processor.

[0254] In step 3850, at least one subwaveform or one or more discontinuity points of the plurality of subwaveforms and discontinuity points are identified as a normal or abnormal electrophysiological signal of the ECG waveform based on the comparison using the processor.

[0255] In step 3860, the ECG waveform for the at least one heartbeat of the beating heart is displayed, one or more markers at a location of the at least one subwaveform or one or more discontinuity points is displayed on the ECG waveform, and the one or more markers are identified as a normal or abnormal cardiac electrophysiological signal using a display device.

[0256] The foregoing disclosure of the preferred embodiments of the present invention has been presented for purposes of illustration and description. It is not intended to be exhaustive or to limit the invention to the precise forms disclosed. Many variations and modifications of the embodiments described herein will be apparent to one of ordinary skill in the art in light of the above disclosure. The scope of the invention is to be defined only by the claims appended hereto, and by their equivalents.

[0257] Further, in describing representative embodiments of the present invention, the specification may have presented the method and/or process of the present invention as a particular sequence of steps. However, to the extent that the method or process does not rely on the particular order of steps set forth herein, the method or process should not be limited to the particular sequence of steps described. As one of ordinary skill in the art would appreciate, other sequences of steps may be possible. Therefore, the particular order of the steps set forth in the specification should not be construed as limitations on the claims. In addition, the claims directed to the method and/or process of the present invention should not be limited to the performance of their steps in the order written, and one skilled in the art can readily appreciate that the sequences may be varied and still remain within the spirit and scope of the present invention.

What is claimed is:

1. A noninvasive electrocardiography (ECG) system for identifying and annotating cardiac electrophysiological signals in an ECG waveform as normal or abnormal during measurement of the ECG waveform, comprising:

two or more electrodes adapted to be located near a beating heart of a patient and attached to the skin of the patient that receive electrical impulses from the beating heart;

a detector that detects the electrical impulses from at least one pair of electrodes of the two or more electrodes and converts the electrical impulses to an ECG waveform for each heartbeat of the beating heart;

a processor that

receives the ECG waveform for at least one heartbeat from the detector, converts the ECG waveform to a frequency domain waveform, separates the frequency domain waveform into two or more different frequency domain waveforms, and converts the two or more different frequency domain waveforms into a plurality of time domain cardiac electrophysiological subwaveforms and discontinuity points between these subwaveforms of the ECG waveform,

- compares the plurality of subwaveforms and discontinuity points to a database of subwaveforms and discontinuity points for cardiac electrophysiological signals of ECG waveforms for a plurality of known and normal and abnormal patients, and identifies at least one subwaveform or one or more discontinuity points of the plurality of subwaveforms and discontinuity points as a normal or abnormal electrophysiological signal of the ECG waveform based on the comparison; and a display device that displays the ECG waveform for the at least one heartbeat of the beating heart, displays one or more markers at a location of the at least one subwaveform or one or more discontinuity points on the ECG waveform, and identifies the one or more markers as a normal or abnormal cardiac electrophysiological signal.
- 2.** The ECG system of claim **1**, wherein the processor converts the ECG waveform to a frequency domain waveform, separates the frequency domain waveform into two or more different frequency domain waveforms, and converts the two or more different frequency domain waveforms into a plurality of time domain cardiac electrophysiological subwaveforms and discontinuity points between these subwaveforms of the ECG waveform using an artificial intelligence algorithm.
- 3.** The ECG system of claim **2**, wherein the artificial intelligence algorithm includes a multivariable calculus algorithm.
- 4.** The ECG system of claim **1**, wherein the processor compares the plurality of subwaveforms and discontinuity points to a database of subwaveforms and discontinuity points for cardiac electrophysiological signals of ECG waveforms for a plurality of known and normal and abnormal patients using a human like artificial intelligence algorithm.
- 5.** The ECG system of claim **4**, wherein the human like artificial intelligence algorithm includes an expert and cardiologist system.
- 6.** The ECG system of claim **4**, wherein the human like artificial intelligence algorithm includes an ECG diagnosis system.
- 7.** The ECG system of claim **4**, wherein the human like artificial intelligence algorithm includes an intelligent signals unsupervised feature learning system.
- 8.** The ECG system of claim **4**, wherein the human like artificial intelligence algorithm includes a general ECG problem solver.
- 9.** The ECG system of claim **4**, wherein the human like artificial intelligence algorithm includes a semantic ECG waveform system.
- 10.** The ECG system of claim **1**, wherein the processor compares the plurality of subwaveforms and discontinuity points to a database of subwaveforms and discontinuity points for cardiac electrophysiological signals of ECG waveforms for a plurality of known and normal and abnormal patients using a non-human like artificial intelligence algorithm.
- 11.** The ECG system of claim **10**, wherein the non-human like artificial intelligence algorithm includes a neural network.
- 12.** The ECG system of claim **10**, wherein the non-human like artificial intelligence algorithm includes a shallow network.
- 13.** The ECG system of claim **10**, wherein the non-human like artificial intelligence algorithm includes a deep learning algorithm.
- 14.** The ECG system of claim **10**, wherein the non-human like artificial intelligence algorithm includes a deep network.
- 15.** The ECG system of claim **10**, wherein the non-human like artificial intelligence algorithm includes a convolution all neural network (CNN).
- 16.** The ECG system of claim **10**, wherein the non-human like artificial intelligence algorithm includes a deep belief net (DBN).
- 17.** The ECG system of claim **10**, wherein the non-human like artificial intelligence algorithm includes a restricted Boltzmann machine (RBM).
- 18.** The ECG system of claim **1**, wherein the processor compares the plurality of subwaveforms and discontinuity points to a database of subwaveforms and discontinuity points for cardiac electrophysiological signals of ECG waveforms for a plurality of known and normal and abnormal patients using a human like artificial intelligence algorithm and a non-human like artificial intelligence algorithm.
- 19.** A method for identifying and annotating cardiac electrophysiological signals in an electrocardiography (ECG) waveform as normal or abnormal during measurement of the ECG waveform, comprising:
- receiving electrical impulses from a beating heart using two or more electrodes;
 - detecting the electrical impulses from at least one pair of electrodes of the two or more electrodes and converting the electrical impulses to an ECG waveform for each heartbeat of the beating heart using a detector;
 - receiving the ECG waveform for at least one heartbeat from the detector, converting the ECG waveform to a frequency domain waveform, separating the frequency domain waveform into two or more different frequency domain waveforms, and converting the two or more different frequency domain waveforms into a plurality of time domain cardiac electrophysiological subwaveforms and discontinuity points between these subwaveforms of the ECG waveform using a processor;
 - comparing the plurality of subwaveforms and discontinuity points to a database of subwaveforms and discontinuity points for cardiac electrophysiological signals of ECG waveforms for a plurality of known and normal and abnormal patients using the processor;
 - identifying at least one subwaveform or one or more discontinuity points of the plurality of subwaveforms and discontinuity points as a normal or abnormal electrophysiological signal of the ECG waveform based on the comparison using the processor; and
 - displaying the ECG waveform for the at least one heartbeat of the beating heart, displaying one or more markers at a location of the at least one subwaveform or one or more discontinuity points on the ECG waveform, and identifying the one or more markers as a normal or abnormal cardiac electrophysiological signal using a display device.
- 20.** An invasive electrocardiography (ECG) system for identifying and annotating cardiac electrophysiological signals in an ECG waveform as normal or abnormal during measurement of the ECG waveform, comprising:
- two or more electrodes placed directly on the surface of a beating heart of a patient that receive electrical impulses from the beating heart;

a detector that detects the electrical impulses from at least one pair of electrodes of the two or more electrodes and converts the electrical impulses to an ECG waveform for each heartbeat of the beating heart;

a processor that

- receives the ECG waveform for at least one heartbeat from the detector, converts the ECG waveform to a frequency domain waveform, separates the frequency domain waveform into two or more different frequency domain waveforms, and converts the two or more different frequency domain waveforms into a plurality of time domain cardiac electrophysiological subwaveforms and discontinuity points between these subwaveforms of the ECG waveform,
- compares the plurality of subwaveforms and discontinuity points to a database of subwaveforms and discontinuity points for cardiac electrophysiological signals of ECG waveforms for a plurality of known and normal and abnormal patients, and
- identifies at least one subwaveform or one or more discontinuity points of the plurality of subwaveforms and discontinuity points as a normal or abnormal electrophysiological signal of the ECG waveform based on the comparison; and

a display device that displays the ECG waveform for the at least one heartbeat of the beating heart, displays one or more markers at a location of the at least one subwaveform or one or more discontinuity points on the ECG waveform, and identifies the one or more markers as a normal or abnormal cardiac electrophysiological signal.

* * * * *

专利名称(译)	自动心电图分析和诊断系统		
公开(公告)号	US20180184931A1	公开(公告)日	2018-07-05
申请号	US15/904543	申请日	2018-02-26
[标]申请(专利权)人(译)	陈广仁 杨荣 蒋中农		
申请(专利权)人(译)	陈, 广仁 杨, 荣 姜, 中农		
当前申请(专利权)人(译)	陈, 广仁 杨, 荣 姜, 中农		
[标]发明人	CHEN GUANGREN YANG RONG JIANG ZHONGNONG		
发明人	CHEN, GUANGREN YANG, RONG JIANG, ZHONGNONG		
IPC分类号	A61B5/04 A61B5/0468 A61B5/00 A61B5/0464 A61B5/046		
CPC分类号	A61B5/04012 A61B5/0468 A61B5/725 A61B5/0464 A61B5/046 A61B5/7257 A61B5/0408		
优先权	62/017185 2014-06-25 US 62/271699 2015-12-28 US 62/271704 2015-12-28 US 62/008435 2014-06-05 US 62/463662 2017-02-26 US		
其他公开文献	US10085663		
外部链接	Espacenet USPTO		

摘要(译)

ECG系统从谐波波形识别和注释ECG波形中的心脏电生理信号。从跳动的心脏接收电脉冲。电脉冲被转换为ECG波形。ECG波形被转换为频域波形，该频域波形又被分成两个或更多个不同的频域波形，这些波形又被转换成多个时域心脏电生理学亚波形和这些子波形之间的不连续点。将多个子波形和不连续点与正常和异常患者的子波形和不连续点的数据库进行比较。从比较中将至少一个子波形或一个或多个不连续点识别为ECG波形的正常或异常电生理信号。ECG波形与一个或多个标记一起显示在至少一个子波形或一个或多个不连续点的位置处。

