



US 20140152436A1

(19) **United States**

(12) **Patent Application Publication**  
**Langer**

(10) **Pub. No.: US 2014/0152436 A1**

(43) **Pub. Date: Jun. 5, 2014**

(54) **DEFIBRILLATION SYSTEM FOR  
NON-MEDICAL ENVIRONMENTS**

**Publication Classification**

(71) Applicant: **HEALTH ALERT, LLC**, Boise, ID  
(US)

(51) **Int. Cl.**  
*A61B 5/00* (2006.01)  
*G06F 19/00* (2006.01)

(72) Inventor: **Alois Antonin Langer**, Harrison City,  
PA (US)

(52) **U.S. Cl.**  
CPC ..... *A61B 5/746* (2013.01); *A61B 5/0022*  
(2013.01); *G06F 19/3418* (2013.01)

(73) Assignee: **HEALTH ALERT, LLC**, Boise, ID  
(US)

USPC ..... **340/539.12**

(21) Appl. No.: **14/173,607**

(57) **ABSTRACT**

(22) Filed: **Feb. 5, 2014**

A defibrillation system having a physiological parameter measuring device for measuring parameters that may indicate a need for a defibrillator; an emergency level detector in communication with the physiological parameter measuring device for detecting emergency level physiological parameters; and a notification device in communication with the emergency level detector for providing notice of the detection of an emergency-level physiological parameter to a caregiver who can then utilize a defibrillator.

**Related U.S. Application Data**

(63) Continuation of application No. 10/764,106, filed on  
Jan. 23, 2004.

(60) Provisional application No. 60/442,330, filed on Jan.  
27, 2003.

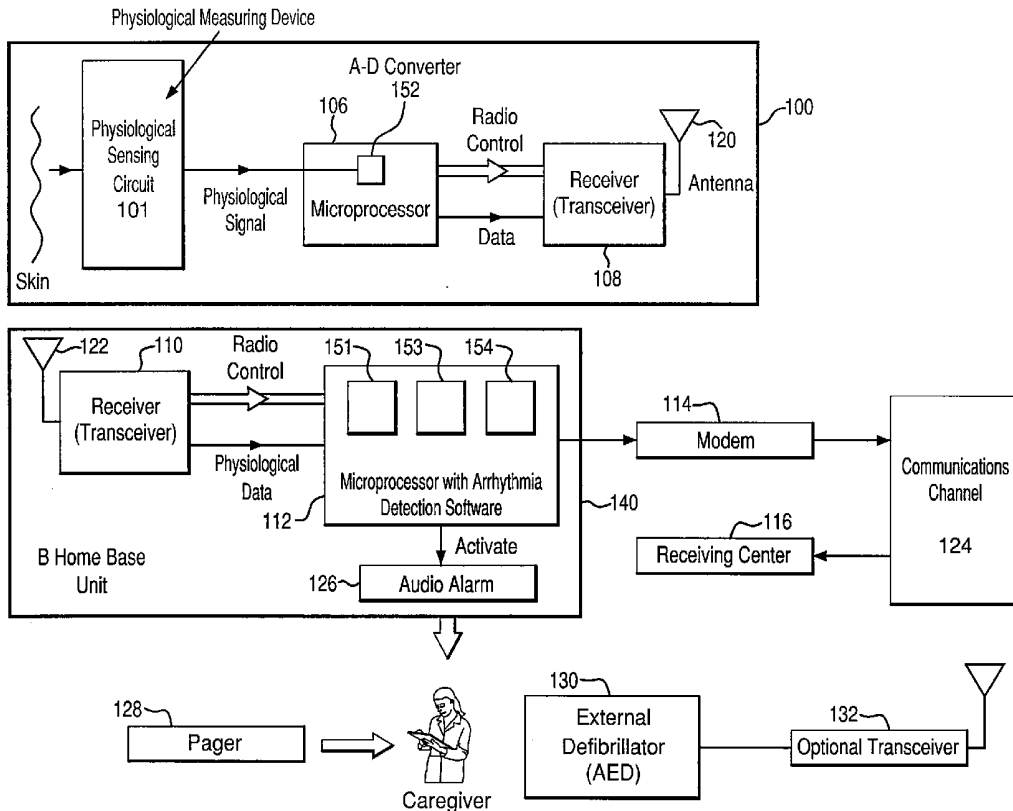

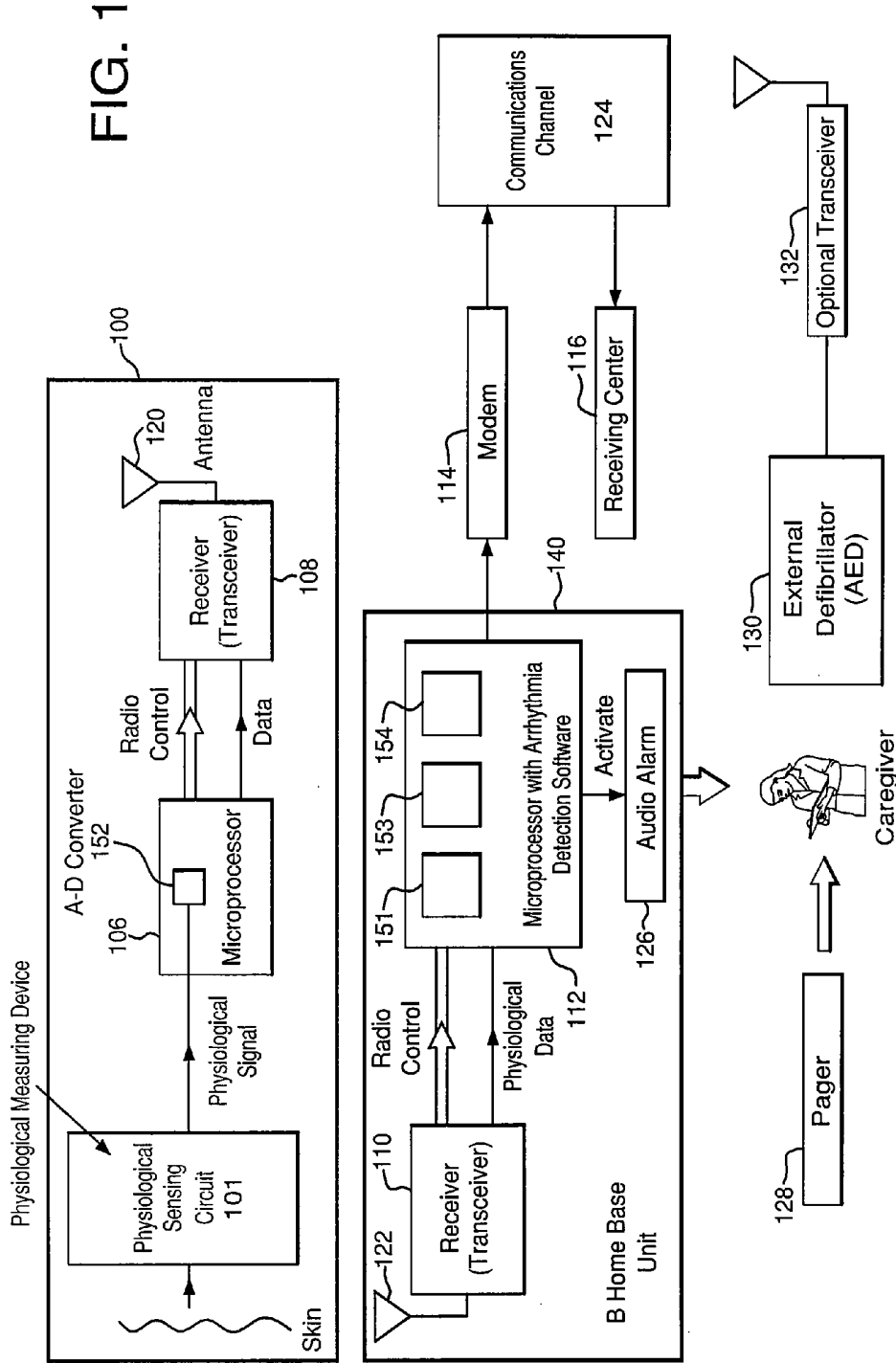

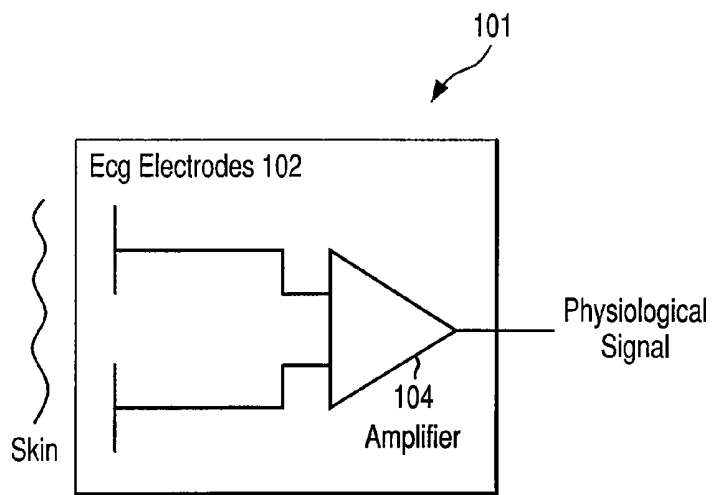

FIG. 2A

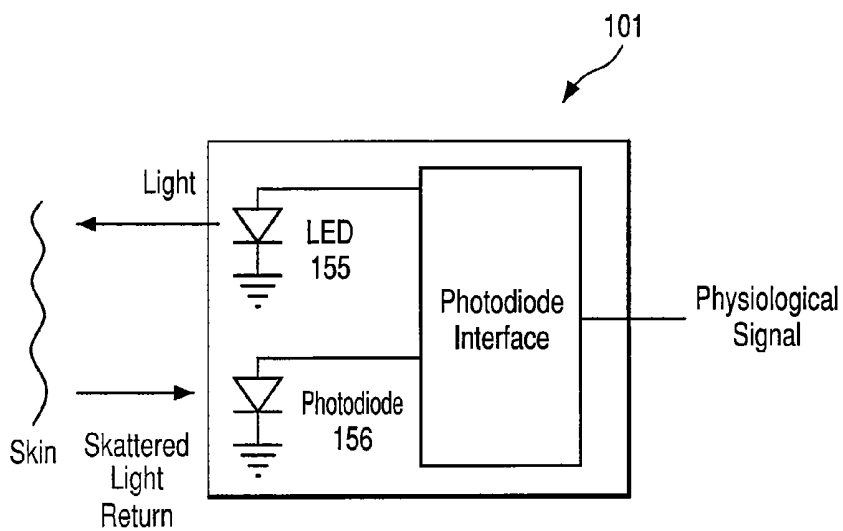

FIG. 2B

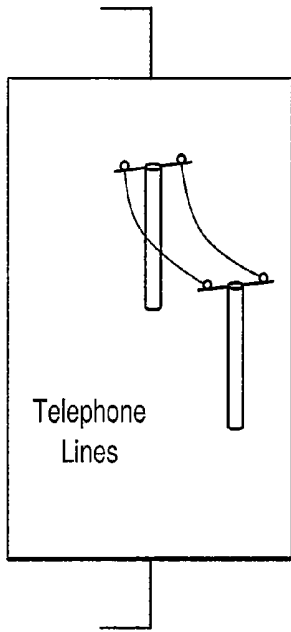

FIG. 3A

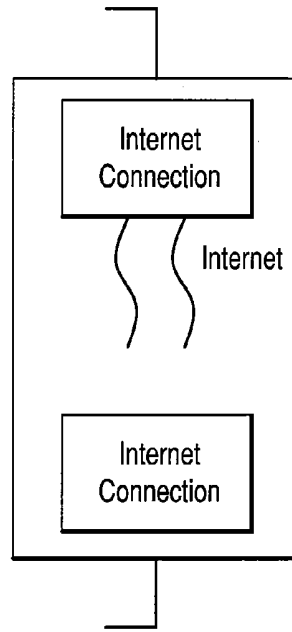

FIG. 3B

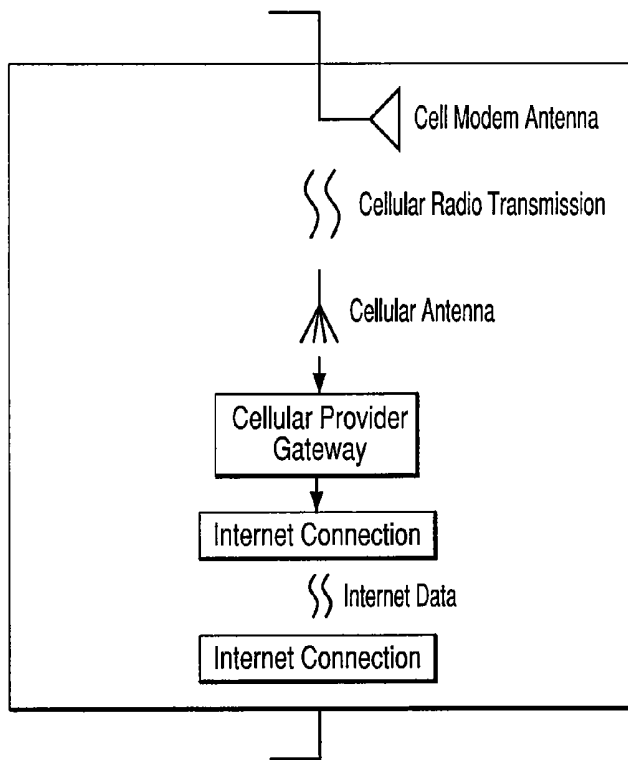

FIG. 3C

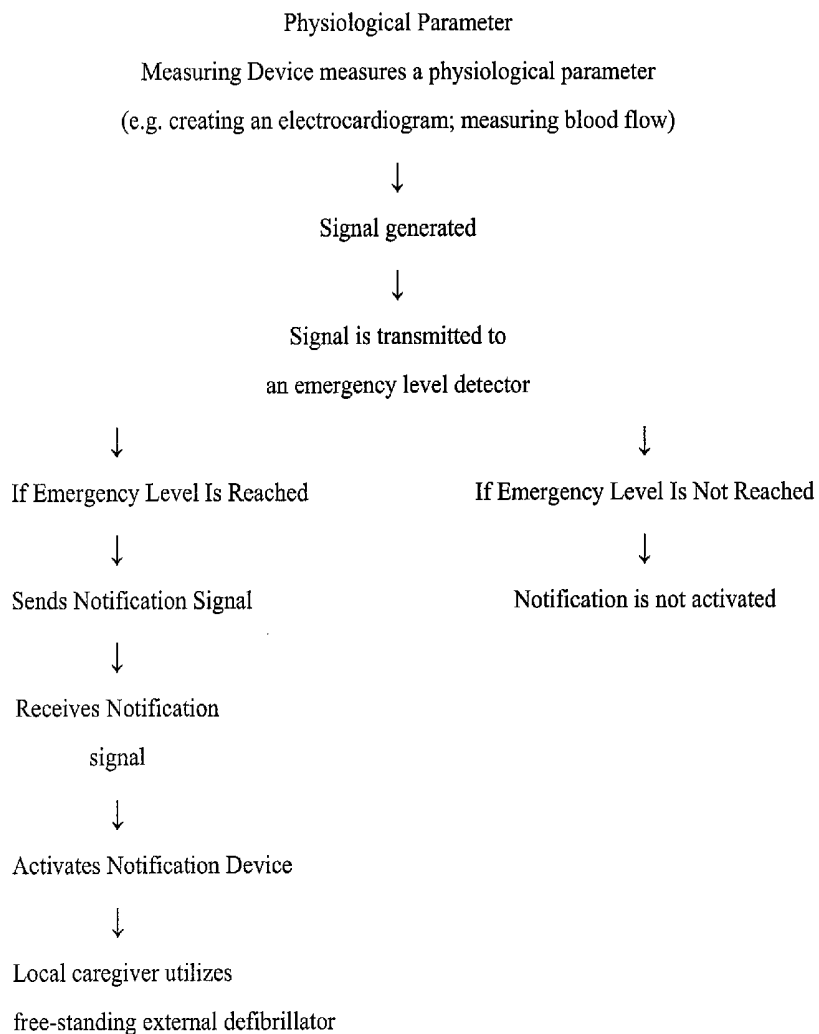
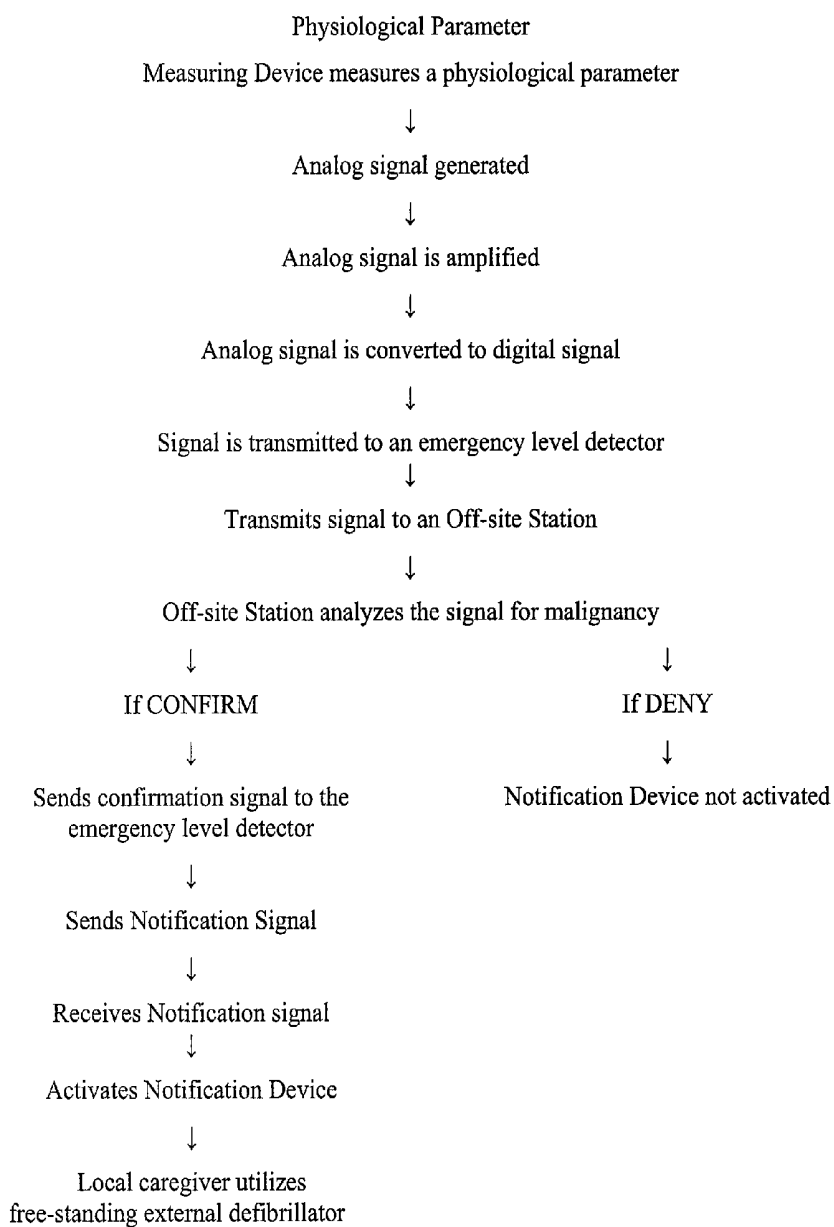

FIG. 4



**FIG. 5**

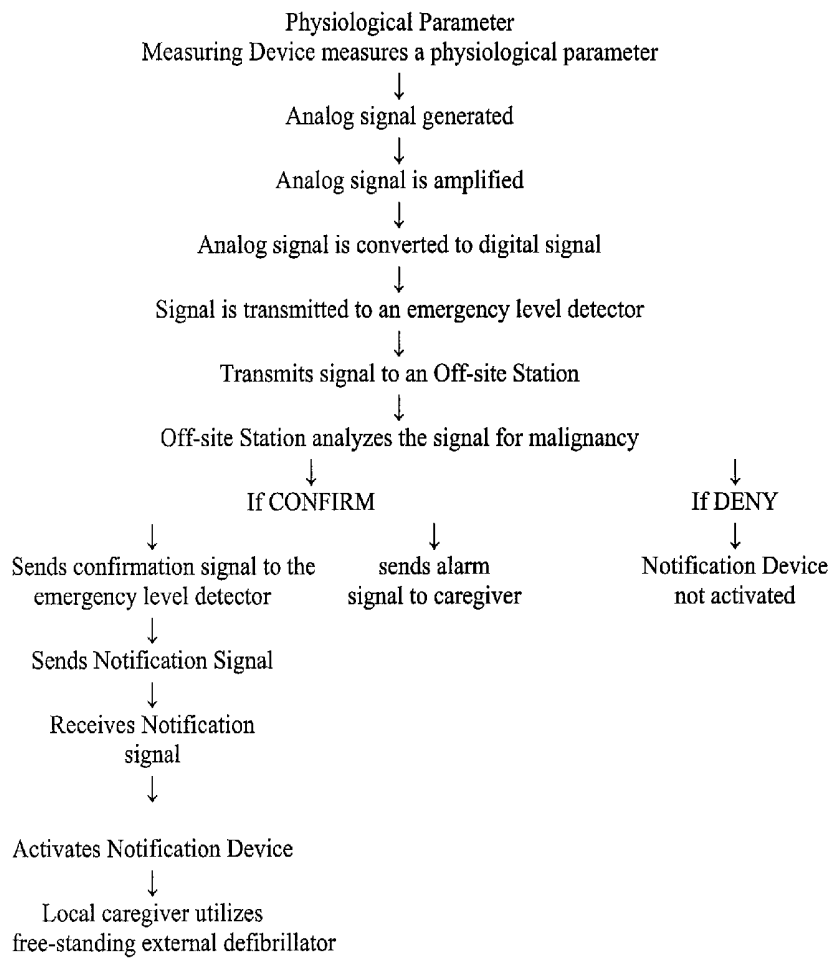

FIG. 6

## DEFIBRILLATION SYSTEM FOR NON-MEDICAL ENVIRONMENTS

[0001] This application claims the benefit of U.S. provisional Application No. 60/442,330, filed Jan. 27, 2003, the disclosure of which is incorporated herein by this reference. This application is further a continuation application of application Ser. No. 10/764,106, filed Jan. 23, 2004, which is pending, and the disclosure of which is incorporated herein by this reference.

### BACKGROUND OF THE INVENTION

[0002] So-called malignant arrhythmias such as ventricular fibrillation (VF) and sustained ventricular tachycardia (VT) are responsible for a large portion of Cardiac Deaths. Various devices have been developed to deal with this problem in non-medical environments; however, no single device is suitable for all patients. Some devices are implantable and suitable only for patients with a well-established and permanent need for such a device, while others are worn externally.

[0003] Microprocessor controlled implantable defibrillators are available, which are capable of automatically terminating various malignant arrhythmias. These devices are in widespread production and have revolutionized the treatment of VF and VT and have saved many thousands of lives. Unfortunately, these devices and the required surgery are expensive, and therefore, the application is limited to permanent implantation. As such these devices are unsuitable for patients who are not hospitalized and are at a temporary increased risk of developing VF or sustained VT such as perhaps patients waiting for a heart transplant.

[0004] There also exist patient worn defibrillators, which can be worn temporarily. Though they are suitable for short-term use, they have the disadvantage of being somewhat bulky and heavy and require the wearing of a large vest which can become perspiration soaked and uncomfortable.

[0005] There is a class of defibrillators called AEDs or Automatic External Defibrillators, which have been designed to be used in non-medical environments and have even been suggested to be used in at home. These are small external defibrillators which were initially designed to be kept at public places such as airports or in airplanes themselves. If a patient goes into a dangerous heart rhythm and collapses, an observer fetches the defibrillator from its storage place, applies it to the patient and then the defibrillator performs the defibrillation with varying degrees of automaticity. When used at home, these would not have the burden of being continuously worn nor have the permanence of surgical implantation.

[0006] The disadvantage of AEDs currently on the market is that they require the response of a person other than the patient. Therefore, these AEDs are ineffective in a situation where another person is unaware of a patient's need for a defibrillator.

[0007] Accordingly, there is a need for a defibrillation system that can be used in non-medical environments, when there is no individual immediately aware of the emergency.

### SUMMARY OF THE INVENTION

[0008] Embodiments of the present inventive defibrillation system provide notification to a caregiver when a situation arises in which application of a defibrillator is advisable, such as the occurrence of malignant arrhythmias, thus allowing the timely lifesaving application of an AED.

[0009] An illustrative embodiment of the invention includes a physiological parameter measuring device for measuring parameters that may indicate a need for a defibrillator;

[0010] an emergency level detector in communication with the physiological parameter measuring device for detecting an emergency level in the physiological parameters specific to those requiring defibrillation or cardioversion; and a notification device in communication with the emergency level detector for providing notice of the detection of an emergency-level physiological parameter to a caregiver who can then utilize a defibrillator. The system will preferably be adapted for non-medical use by being small and portable, will be dedicated to a single patient, have backup power in case of a power outage, and have a caregiver notification device capable of notifying the caregiver in a variety of non-medical environments.

### DESCRIPTION OF THE DRAWINGS

[0011] The invention is best understood from the following detailed description when read with the accompanying drawings.

[0012] FIG. 1 depicts a defibrillation system according to an illustrative embodiment of the invention.

[0013] FIG. 2A depicts the physiological parameter measuring device 101 according to one embodiment of the invention.

[0014] FIG. 2B depicts the physiological parameter measuring device 101 according to another embodiment of the invention.

[0015] FIG. 3A depicts the data communication channel 124 according to one embodiment of the invention.

[0016] FIG. 3B depicts the data communication channel 124 according to another embodiment of the invention.

[0017] FIG. 3C depicts the data communication channel 124 according to another embodiment of the invention.

[0018] FIG. 4 is a flow chart illustrative of the steps of one embodiment of the invention.

[0019] FIG. 5 is a flow chart illustrative of the steps of one embodiment of the invention.

[0020] FIG. 6 is a flow chart illustrative of the steps of one embodiment of the invention.

### DESCRIPTION OF THE INVENTION

[0021] The present invention is an alarm system that may be used in a non-medical environment, such as in a home, and is designed to notify a caregiver when a patient requires defibrillation. In an illustrative embodiment, a patient wears a strap preferably containing long-term ECG electrodes 102 such as capacitively-coupled skin electrodes, though standard electrodes with wires leading to a small encased device could alternatively be used. Capacitive electrodes, if desired, can be used for patient comfort, since the patient likely will wear the device for an extended period of time. These electrodes provide a physiological parameter signal from the patient, in this illustrative case an ECG. Amplifier 104 raises the ECG level to a point to be compatible with an analog to digital converter 152 connected to or contained in a microprocessor 106. The microprocessor's software includes a ventricular fibrillation detecting algorithm. Other life-threatening rhythms treatable by a defibrillator may also be detected, but for simplicity these will collectively sometimes be called VF and detectable by a VF detector. Ventricular fibrillation detection algorithms for

microprocessors are well known in the art, for example as described in U.S. Pat. No. 6,263,238. Upon occurrence of VF as detected by the microprocessor, an alarm is sounded, alerting someone in proximity to the patient, a so-called caregiver, who then applies an external defibrillator and proceeds to defibrillate.

**[0022]** The system as described above has several limitations, first, that a strap containing all the necessary hardware especially the battery and alarm, might be too heavy to be worn comfortably and placing the alarm on the patient would be extremely frightening should the fibrillation detector make a mistake. Therefore, in another embodiment of the invention, the sensor and the arrhythmia detector are separated, and a radio telemetry transmitter sends the patient's ECG to a receiver located somewhere remote from the patient but where it will alert a caregiver. The remote receiver contains the microprocessor and the audio alarm. This also has the advantage of allowing longer battery life in the patient transmitter since the microprocessor is no longer patient worn. Of course other types of alarms can be used as a notification device such as lights and pagers or combinations thereof. Although at present the detector portion should be separated for patient comfort, it is possible that detectors will be made available in a form that would not necessitate separation.

**[0023]** Other physiological parameters can be used to sense malignant rhythms. FIG. 2B shows another embodiment of the physiological parameter measuring device of the invention, a light emitting diode (LED) **155** sends infrared light into the skin while photosensors **156** detect the scattered light. It is well known to those skilled in the art that a waveform proportional to blood flow can be derived from the photosensor in a manner similar to that used in pulse oximeters. See U.S. Pat. No. 4,807,630 for example. This waveform's pulsatile nature will change when malignant arrhythmias occur and can be used to detect them. Of course the optical method can be used alone or in combination with the ECG or even other physiological parameters. It could be used in a completely patient-worn system or in a system where the detection and alarm function are separated by telemetry as discussed previously.

**[0024]** Fibrillation detectors, or other physiological parameter, emergency-level detectors, while accurate, are not perfect and the possibility of false alarms must be considered. In another embodiment of the invention, an extra confirming step is added between the fibrillation detector and the alarm function as an emergency level verification system. In this version of the invention, after fibrillation is detected, the signal corresponding to the sensed physiological parameter (s) is sent via communication channel **124** (e.g., a phone line) to a remote location such as an off-site central receiving station **116** for human review. The personnel at the receiving center (central receiving station) evaluate the physiological data to confirm a malignant rhythm. They then send a confirmation signal to the detector-alarm device enabling the alarm to be activated or they perhaps directly send out an alarm to the caregiver, for example using a pager or cell phone. Communication between the patient's location and the receiving center can be by phone as shown in FIG. 3A or as in the inventor's U.S. Pat. No. 5,966,692 or by other communication means such as the Internet FIG. 3B, or other wireless means (FIG. 3C).

**[0025]** FIG. 1 depicts an illustrative embodiment of a defibrillation system. Box **100** includes illustrative patient-worn components. In FIG. 2A the ECG electrodes **102** pro-

vide an analog ECG signal to an amplifier **104**. A microprocessor **106** performs an analog to digital conversion on the signal and sends this digitized signal to a radio telemetry transmitter **108**. Preferably, the digitized signal is transmitted continuously. Transmitter **108** is preferably a long-range transmitter.

**[0026]** Box **140** shows a second device, which will be referred to as a home base unit, which functions in conjunction with the patient worn components. Home base unit **140** is placed at the patient location and houses a receiver **110** and a second microprocessor **112**. A signal transmitted by antenna **120** of the patient worn portion of the system is received by antenna **122** of home base unit **140**. Home base unit **140** performs analysis on the ECG signal received. When an arrhythmia requiring defibrillation is sensed, microprocessor **112** activates a modem **114**, or other communications device, and sends the ECG data to a receiving center **116** directly or through an Internet service provider. Modem **114**, for example, may be of conventional, cable or DSL variety, perhaps with permanent connection to the Internet, or the transmission may also be wireless as through a conventional cellular voice and data network or dedicated wireless data network such as the new 1xEV-DO (Evolution Data Only) wireless data network.

**[0027]** Personnel at the receiving center verify (or not) the rhythm and send an enabling signal back through data communication channel **124**, such as a phone line, or by the wireless connection, activating an audio alarm **126** at the patient's location. At the same time, receiving center **116** sends a page to an optional pager **128** worn by the caregiver. This is easily done for example through SNPP or Simple Network Paging Protocol or perhaps another protocol from the Central Receiving Center over the Internet. The two warning devices alert the caregiver to the need for defibrillation; the caregiver fetches the home external defibrillator **130** and defibrillates the patient. Optionally, the defibrillator has a radio interface **132** and can communicate with the home base unit allowing the central receiving center to control the defibrillator.

**[0028]** The embodiments presented above are those believed to be most suitable for commercial production and use. The invention will now be further described with respect to a basic embodiment and associated additions and variations.

**[0029]** The basic defibrillation system comprises a physiological parameter measuring device **101**, an emergency level detector **151** in communication with the physiological parameter measuring device for detecting emergency level physiological parameters, and a notification device in communication with the emergency level detector **151** for providing notice of the detection of an emergency-level physiological parameter to a caregiver. As used herein a caregiver includes any individual that may respond to a notification such as an alarm or page, and also includes personnel alerted through a central receiving station. A defibrillator is used in conjunction with the defibrillation system and may be sold as part of the system or separately.

**[0030]** The physiological parameter measuring device measures parameters that may be used to determine if an emergency situation has occurred necessitating use of the defibrillator. Examples of physiological parameter measuring devices include, but are not limited to ECGs, blood flow measurement devices, Pulse Ox sensors, respiration sensors, body movement sensors, and others.

**[0031]** Measurements are provided to the emergency-level detector for a determination of whether the measured parameters have reached an emergency level, necessitating use of a defibrillator. The physiological parameter measuring device and the emergency-level detector may be incorporated into a single device or be separate devices in communication with one another either wirelessly or through hard wiring.

**[0032]** The defibrillation system may include an emergency level verification system **154** configured to communicate with a central receiving station. The central receiving station may receive communications from the notification components of the system, directly from the physiological parameter measuring device or from the emergency-level detector. If the signal is received from the physiological parameter measuring device, a determination of emergency levels is performed at the receiving station. It is also possible that the signal from the physiological parameter measuring device is routed to somewhere other than the central receiving station for analysis of whether an emergency-level has been reached, before being routed to the central receiving station. Regardless of which component or components are in communication with a central receiving station, the receiving station can serve to verify whether defibrillation is needed.

**[0033]** The central receiving station may also be in communication with the defibrillator so that the defibrillator may be remotely operated, calibrated, tested or otherwise adjusted.

**[0034]** Embodiments of the defibrillation system may also include stored patient data **153**. This data may be available for use for example by the emergency level detection device, the physiological parameter measuring device or the central monitoring station. The system would be configured so the patient data is communicated to the proper system component. The stored patient data **153** may include for example, medical data, patient location data, and emergency contact information.

**[0035]** The invention also includes a method of using a defibrillator. The method includes measuring a physiological parameter, providing the physiological parameter measurement to an emergency level detector **151**, determining if the parameter is at an emergency level, activating a notification device if the physiological parameter is at an emergency level. The notification is received by a caregiver who then utilizes a defibrillator. The methods of the invention include use of components or procedures described herein.

**[0036]** While the invention has been described by illustrative embodiments, additional advantages and modifications will occur to those skilled in the art. Therefore, the invention in its broader aspects is not limited to specific details shown and described herein. Modifications, for example, to the physiological parameters measured, emergency-level detection devices and forms of notification, may be made without departing from the spirit and scope of the invention. Accordingly, it is intended that the invention not be limited to the specific illustrative embodiments, but be interpreted within the full spirit and scope of the appended claims and their equivalents.

1. A warning and defibrillation system for use by an individual having an increased risk of developing a malignant arrhythmia, said system comprising:

- a plurality of proximal components and a central receiving station which is located remote from said individual;
- said proximal components located proximal to said individual, said proximal components comprising an exter-

nal defibrillator, a physiological parameter measuring device, an emergency level detector, a communications device, and a notification device;

wherein said external defibrillator is configured for use by a caregiver;

wherein said physiological parameter measuring device is adapted to be worn on a body of said individual, wherein said physiological parameter measuring device measures at least one physiological parameter of said individual, and wherein said physiological parameter measuring device generates a first signal representing said measured at least one physiological parameter;

wherein said emergency level detector receives said first signal, wherein said emergency level detector monitors said first signal for emergency level physiological parameters, and wherein said emergency level detector generates a second signal upon detection of emergency level physiological parameters;

wherein upon detection of emergency level physiological parameters said communications device communicates at least one of said first signal and said second signal to said central receiving station;

said central receiving station located remote from said individual, said central receiving station configured for receiving said at least one of said first signal and said second signal from said communications device, said central receiving station comprising an emergency level verification system for evaluating said at least one of said first signal and said second signal to confirm if emergency level physiological parameters are present, said central receiving station further comprising a confirmation signal generator for generating a confirmation signal upon the confirmation of the presence of emergency level physiological parameters;

wherein upon said confirmation of the presence of emergency level physiological parameters said central receiving station transmits said confirmation signal to said at least one notification device, and wherein upon receipt of said confirmation signal, said at least one notification device alerts the caregiver that said external defibrillator needs to be utilized on said individual.

2. The warning and defibrillation system of claim 1, wherein said at least one notification device comprises an alarm.

3. The warning and defibrillation system of claim 2, wherein said alarm is an audio alarm at the individual's location.

4. The warning and defibrillation system of claim 2, wherein said alarm is sent to the caregiver's cell phone.

5. A warning and defibrillation system for use by an individual having an increased risk of developing a malignant arrhythmia, said system comprising:

an external defibrillator, a home base unit, and a central receiving station;

wherein said external defibrillator is located proximal to said individual, wherein

said home base unit is located proximal to said individual, and wherein said central receiving station is located remote from said individual;

said external defibrillator is configured for use by a caregiver;

said home base unit comprising a physiological parameter measuring device, an emergency level detector, a communications device, and at least one notification device;

said physiological parameter measuring device is adapted to be worn on a body of said individual, wherein said physiological parameter measuring device measures at least one physiological parameter of said individual, and wherein said physiological parameter measuring device generates a first signal representing said measured at least one physiological parameter;

said emergency level detector is receives said first signal, wherein said emergency level detector monitors said first signal for emergency level physiological parameters, and wherein said emergency level detector generates a second signal upon detection of emergency level physiological parameters;

wherein upon detection of emergency level physiological parameters said communications device is configured for communicating at least one of said first signal and said second signal to said central receiving station;

said central receiving station configured for receiving said at least one of said first signal and said second signal from said communications device, said central receiving station comprising an emergency level verification system for evaluating said at least one of said first signal and said second signal to confirm if emergency level physiological parameters are present, said central receiving station further comprising a confirmation signal generator for generating a confirmation signal upon the confirmation of the presence of emergency level physiological parameters; and

wherein upon said confirmation of the presence of emergency level physiological parameters said central receiving station transmits said confirmation signal to said at least one notification device, and wherein upon receipt of said confirmation signal, said at least one notification device alerts the caregiver that said external defibrillator needs to be utilized on said individual.

**6.** A warning system comprising:

an external defibrillator for use by a caregiver;

a physiological parameter measuring device adapted to be worn on a body of an individual, said physiological parameter measuring device for measuring at least one physiological parameter of said individual, and for generating a first signal representing said measured at least one physiological parameter;

an emergency level detector, said emergency level detector receiving said first signal, said emergency level detector monitoring said first signal for emergency level physi-

ological parameters and generating a second signal upon detection of emergency level physiological parameters; at least one notification device;

a central receiving station receiving said second signal, said central receiving station comprising an emergency level verification system for evaluating said second signal to confirm if emergency level physiological parameters are present, said central receiving station further comprising a confirmation signal generator for generating a confirmation signal upon the confirmation of the presence of emergency level physiological parameters, wherein upon said confirmation of the presence of emergency level physiological parameters said central receiving station transmits said confirmation signal to said at least one notification device, and wherein upon receipt of said confirmation signal, said at least one notification device alerts the caregiver that said external defibrillator needs to be utilized on said individual.

**7.** The warning system of claim **6**, wherein said at least one notification device comprises one or more of the following: an audio alarm, an alarm sent to a pager, and an alarm sent to a cell phone.

**8.** The warning system of claim **6**, wherein the central receiving station receives the second signal at least in part via a wireless network.

**9.** The warning system of claim **6**, wherein said emergency level detector and said notification device together comprise a receiver.

**10.** The warning system of claim **9**, wherein the receiver is not directly worn by said individual.

**11.** The warning system of claim **6**, wherein the central receiving station is in communication with said external defibrillator, said central receiving station adapted to remotely operate, calibrate, test, or adjust said external defibrillator.

**12.** The warning system of claim **6**, wherein the second signal includes data relating to the location of the individual.

**13.** The warning system of claim **6**, wherein the central receiving station sends a page to the caregiver.

**14.** The warning system of claim **6**, further comprising a wireless communication device for communicating said first signal to the emergency level detector.

**15.** The warning system of claim **14**, where the wireless communication device includes a radio telemetry channel.

**16-24.** (canceled)

\* \* \* \* \*

专利名称(译)	用于非医疗环境的除颤系统		
公开(公告)号	<a href="#">US20140152436A1</a>	公开(公告)日	2014-06-05
申请号	US14/173607	申请日	2014-02-05
[标]申请(专利权)人(译)	健康警报		
申请(专利权)人(译)	健康警报, LLC		
当前申请(专利权)人(译)	健康警报, LLC		
[标]发明人	LANGER ALOIS ANTONIN		
发明人	LANGER, ALOIS ANTONIN		
IPC分类号	A61B5/00 G06F19/00 A61N A61N1/39		
CPC分类号	A61B5/746 G06F19/3418 A61B5/0022 A61N1/36514 A61N1/37258 A61N1/3904 A61N1/3993 G16H40/63		
优先权	60/442330 2003-01-27 US		
外部链接	<a href="#">Espacenet</a> <a href="#">USPTO</a>		

摘要(译)

一种除颤系统，具有生理参数测量装置，用于测量可能指示需要除颤器的参数；紧急水平检测器，与生理参数测量装置通信，用于检测紧急水平生理参数；以及与紧急程度检测器通信的通知装置，用于向护理人员提供检测紧急程度生理参数的通知，然后护理人员可以使用除颤器。

