



US009925387B2

(12) **United States Patent**
Kaib et al.

(10) **Patent No.:** **US 9,925,387 B2**
(45) **Date of Patent:** **Mar. 27, 2018**

(54) **REMOTE MEDICAL DEVICE ALARM**

(56) **References Cited**

(71) Applicant: **ZOLL MEDICAL CORPORATION**,
Chelmsford, MA (US)

U.S. PATENT DOCUMENTS

4,094,310 A 6/1978 McEachern et al.
4,632,122 A 12/1986 Johansson et al.
(Continued)

(72) Inventors: **Thomas E. Kaib**, North Huntingdon,
PA (US); **Shane S. Volpe**, Saltsburg, PA
(US); **Richard A. Rattanni**, Verona, PA
(US)

FOREIGN PATENT DOCUMENTS

EP 0295497 B1 9/1993
EP 0335356 B1 3/1996
(Continued)

(73) Assignee: **ZOLL Medical Corporation**,
Chelmsford, MA (US)

(*) Notice: Subject to any disclaimer, the term of this
patent is extended or adjusted under 35
U.S.C. 154(b) by 0 days.

OTHER PUBLICATIONS

American Journal of Respiratory and Critical Care Medicine, vol.
166, pp. 111-117 (2002), American Thoracic Society, ATS State-
ment: Guidelines for the Six-Minute Walk Test, available at [http://
ajrccm.atsjournals.org/cgi/content/full/166/1/111](http://ajrccm.atsjournals.org/cgi/content/full/166/1/111).

(21) Appl. No.: **14/579,615**

(Continued)

(22) Filed: **Dec. 22, 2014**

(65) **Prior Publication Data**

US 2015/0109125 A1 Apr. 23, 2015

Primary Examiner — Travis Hunnings

(74) *Attorney, Agent, or Firm* — ZOLL Medical
Corporation

Related U.S. Application Data

(63) Continuation of application No. 13/286,533, filed on
Nov. 1, 2011.

(Continued)

(51) **Int. Cl.**
G08B 1/08 (2006.01)
A61N 1/39 (2006.01)

(Continued)

(52) **U.S. Cl.**
CPC **A61N 1/3993** (2013.01); **A61B 5/0022**
(2013.01); **A61B 5/01** (2013.01);

(Continued)

(58) **Field of Classification Search**
CPC G08B 3/10; G08B 25/10; A61N 1/3993;
A61N 1/08

(Continued)

(57) **ABSTRACT**

A remote alarm for use with a wearable defibrillator. The
remote alarm may be a wearable remote device including a
strap for disposing the wearable remote device on a wrist of
a patient and communications circuitry disposed in the
wearable remote device to wirelessly communicate with the
wearable defibrillator. The wearable remote device may be
configured to receive alarms, voice messages and prompts
issued by the wearable defibrillator and to repeat those
alarms, voice messages and prompts in a manner that can
more easily be perceived by a patient wearing the wearable
defibrillator or a bystander. The wearable remote device may
further be configured to take certain actions depending upon
the content of the communication, such as sending a tele-
phone message to alert emergency personnel to the identity,
location and medical condition of the patient, or sending an
email to a friend, caregiver, or relative.

31 Claims, 4 Drawing Sheets

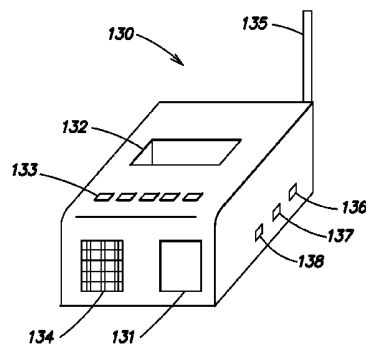
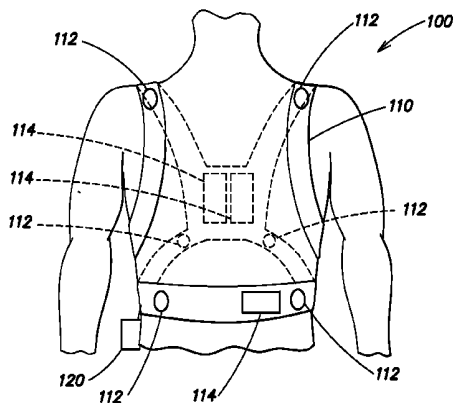

Related U.S. Application Data

			7,794,384 B2 *	9/2010	Sugiura et al.	600/16
			7,831,303 B2	11/2010	Rueter et al.	
			7,974,689 B2	7/2011	Volpe et al.	
			7,991,460 B2	8/2011	Fischell et al.	
			8,121,683 B2	2/2012	Bucher et al.	
			8,140,154 B2	3/2012	Donnelly et al.	
			8,271,082 B2	9/2012	Donnelly et al.	
			8,290,574 B2	10/2012	Feild et al.	
			8,364,221 B2	1/2013	Mannheimer et al.	
			8,369,944 B2 *	2/2013	Macho et al.	607/5
			8,428,704 B2	4/2013	Johnson et al.	
			9,060,683 B2 *	6/2015	Tran	
			2003/0004547 A1	1/2003	Owen et al.	
			2003/0095648 A1	5/2003	Kaib et al.	
			2003/0149462 A1	8/2003	White et al.	
			2003/0158593 A1	8/2003	Heilman et al.	
			2003/0174049 A1	9/2003	Beigel et al.	
			2003/0195567 A1	10/2003	Jayne et al.	
			2003/0212311 A1	11/2003	Nova et al.	
			2004/0204743 A1 *	10/2004	McGrath et al.	607/5
			2005/0038345 A1 *	2/2005	Gorgenberg et al.	600/485
			2005/0049515 A1	3/2005	Misczynski et al.	
			2005/0131465 A1	6/2005	Freeman et al.	
			2005/0177051 A1	8/2005	Almen	
			2005/0246199 A1	11/2005	Futch	
			2005/0261598 A1 *	11/2005	Banet et al.	600/513
			2006/0036292 A1	2/2006	Smith et al.	
			2006/0085049 A1	4/2006	Cory et al.	
			2006/0136004 A1 *	6/2006	Cowan et al.	607/33
			2006/0160522 A1	7/2006	Jennings	
			2006/0178706 A1	8/2006	Lisogurski et al.	
			2006/0270952 A1	11/2006	Freeman et al.	
			2007/0118056 A1	5/2007	Wang et al.	
			2007/0161913 A1	7/2007	Farrell et al.	
			2007/0169364 A1	7/2007	Townsend et al.	
			2007/0239214 A1	10/2007	Cinbis	
			2007/0239220 A1	10/2007	Greenhut et al.	
			2007/0265671 A1	11/2007	Roberts et al.	
			2008/0004536 A1	1/2008	Baxi et al.	
			2008/0004904 A1	1/2008	Tran	
			2008/0030656 A1	2/2008	Watson et al.	
			2008/0033495 A1	2/2008	Kumar	
			2008/0045815 A1	2/2008	Derchak et al.	
			2008/0058884 A1	3/2008	Matos	
			2008/0103402 A1	5/2008	Stickney et al.	
			2008/0177341 A1	7/2008	Bowers	
			2008/0249591 A1	10/2008	Gaw et al.	
			2008/0287749 A1	11/2008	Reuter	
			2008/0294019 A1	11/2008	Tran	
			2008/0306562 A1	12/2008	Donnelly et al.	
			2009/0005827 A1	1/2009	Weintraub et al.	
			2009/0073991 A1	3/2009	Landrum et al.	
			2009/0076336 A1	3/2009	Mazar et al.	
			2009/0076340 A1	3/2009	Libbus et al.	
			2009/0076341 A1	3/2009	James et al.	
			2009/0076342 A1	3/2009	Amurthur et al.	
			2009/0076343 A1	3/2009	James et al.	
			2009/0076344 A1	3/2009	Libbus et al.	
			2009/0076345 A1	3/2009	Manicka et al.	
			2009/0076346 A1	3/2009	James et al.	
			2009/0076348 A1	3/2009	Manicka et al.	
			2009/0076349 A1	3/2009	Libbus et al.	
			2009/0076350 A1	3/2009	Bly et al.	
			2009/0076363 A1	3/2009	Bly et al.	
			2009/0076364 A1	3/2009	Libbus et al.	
			2009/0076397 A1	3/2009	Libbus et al.	
			2009/0076405 A1	3/2009	Amurthur et al.	
			2009/0076410 A1	3/2009	Libbus et al.	
			2009/0076559 A1	3/2009	Libbus et al.	
			2009/0093687 A1	4/2009	Telfort et al.	
			2009/0096417 A1 *	4/2009	Idzik et al.	320/115
			2009/0138059 A1	5/2009	Ouwerkerk	
			2009/0234410 A1	9/2009	Libbus et al.	
			2009/0264792 A1	10/2009	Mazar	
			2009/0275848 A1	11/2009	Brockway et al.	
			2009/0287120 A1	11/2009	Ferren et al.	
			2009/0292194 A1	11/2009	Libbus et al.	
			2009/0307266 A1	12/2009	Fleizach et al.	
			2009/0318779 A1	12/2009	Tran	

(56) References Cited

U.S. PATENT DOCUMENTS

4,928,690 A	5/1990	Heilman et al.	
4,978,926 A	12/1990	Zerod et al.	
5,062,834 A	11/1991	Gross et al.	
5,078,134 A	1/1992	Heilman et al.	
5,348,008 A	9/1994	Bornn et al.	
5,365,932 A	11/1994	Greenhut	
5,652,570 A *	7/1997	Lepkofker	340/573.4
5,662,689 A	9/1997	Elsberry et al.	
5,718,242 A	2/1998	McClure et al.	
5,738,102 A	4/1998	Lemelson	
5,741,306 A	4/1998	Glegyak et al.	
5,758,443 A	6/1998	Pedrazzini	
5,792,190 A	8/1998	Olson et al.	
5,929,601 A	7/1999	Kaib et al.	
5,944,669 A	8/1999	Kaib	
6,016,445 A	1/2000	Baura	
6,065,154 A	5/2000	Hulings et al.	
6,097,987 A	8/2000	Milani	
6,169,397 B1	1/2001	Steinbach et al.	
6,221,010 B1	4/2001	Lucas	
6,253,099 B1	6/2001	Oskin et al.	
6,280,461 B1	8/2001	Glegyak et al.	
6,390,996 B1	5/2002	Halperin et al.	
6,405,082 B1	6/2002	Borgenicht	
6,406,426 B1	6/2002	Reuss et al.	
6,602,191 B2	8/2003	Quy	
6,609,023 B1 *	8/2003	Fischeii et al.	600/515
6,681,003 B2	1/2004	Linder et al.	
6,690,969 B2	2/2004	Bystrom et al.	
6,736,759 B1	5/2004	Stubbs et al.	
6,804,554 B2	10/2004	Ujhelyi et al.	
6,827,695 B2	12/2004	Palazzolo et al.	
6,908,437 B2	6/2005	Bardy	
6,980,112 B2 *	12/2005	Nee	340/573.1
6,990,373 B2	1/2006	Jayne et al.	
7,088,233 B2	8/2006	Menard	
7,149,579 B1	12/2006	Koh et al.	
7,220,235 B2	5/2007	Geheb et al.	
7,307,509 B2	12/2007	Chriss	
7,310,553 B2	12/2007	Freeman	
7,340,296 B2	3/2008	Stahmann et al.	
7,427,921 B2	9/2008	Van Woudenberg	
7,453,354 B2	11/2008	Reiter et al.	
7,488,293 B2	2/2009	Marcovecchio et al.	

(56)

References Cited

U.S. PATENT DOCUMENTS

2010/0052892 A1 3/2010 Allen et al.
 2010/0052897 A1 3/2010 Allen et al.
 2010/0056881 A1 3/2010 Libbus et al.
 2010/0069735 A1 3/2010 Berkner
 2010/0076513 A1 3/2010 Warren et al.
 2010/0102832 A1* 4/2010 Bartling et al. 324/679
 2010/0114243 A1 5/2010 Nowak et al.
 2010/0198094 A1 8/2010 Turicchia et al.
 2010/0234716 A1 9/2010 Engel
 2010/0241181 A1 9/2010 Savage et al.
 2010/0295674 A1 11/2010 Hsieh et al.
 2010/0298899 A1 11/2010 Donnelly et al.
 2011/0022105 A9* 1/2011 Owen et al. 607/5
 2011/0054264 A1 3/2011 Fischell et al.
 2011/0080294 A1 4/2011 Tanishima et al.
 2011/0093840 A1 4/2011 Pynenburg et al.
 2011/0098765 A1 4/2011 Patel
 2011/0288604 A1 11/2011 Kaib et al.
 2011/0288605 A1 11/2011 Kaib et al.
 2012/0011382 A1 1/2012 Volpe et al.
 2012/0053479 A1 3/2012 Hopfenfeld
 2012/0112903 A1 5/2012 Kaib et al.
 2012/0146797 A1 6/2012 Oskin et al.
 2012/0158075 A1 6/2012 Kaib et al.
 2012/0165684 A1 6/2012 Sholder

FOREIGN PATENT DOCUMENTS

EP 1642616 A2 4/2006
 EP 1455640 B1 1/2008

EP 1720446 B1 7/2010
 JP 5115450 A 5/1993
 JP 2003260145 A 9/2003
 JP 2008513112 A 5/2008
 JP 2008302225 A 12/2008
 JP 2008302228 A 12/2008
 JP 2009510631 A 3/2009
 JP 2009521260 A 6/2009
 WO 200002484 A1 1/2000
 WO 2004054656 A1 7/2004
 WO 2004067083 A2 8/2004
 WO 2005082454 A1 9/2005
 WO 2006050235 A1 5/2006
 WO 2007019325 A2 2/2007
 WO 2007077997 A1 7/2007
 WO 2009034506 A1 3/2009
 WO 2010025432 A1 3/2010

OTHER PUBLICATIONS

DeBock, et al., "Captopril treatment of chronic heart failure in the very old," J. Gerontol. (1994) 49: M148-M152.
 International Search Report and Written Opinion from corresponding International Application No. PCT/US2011/059345, dated Jan. 25, 2012.
 O'Keeffe et al., "Reproducibility and responsiveness of quality of life assessment and six minute walk test in elderly heart failure patients," Heart (1998) 80: 377-382.

* cited by examiner

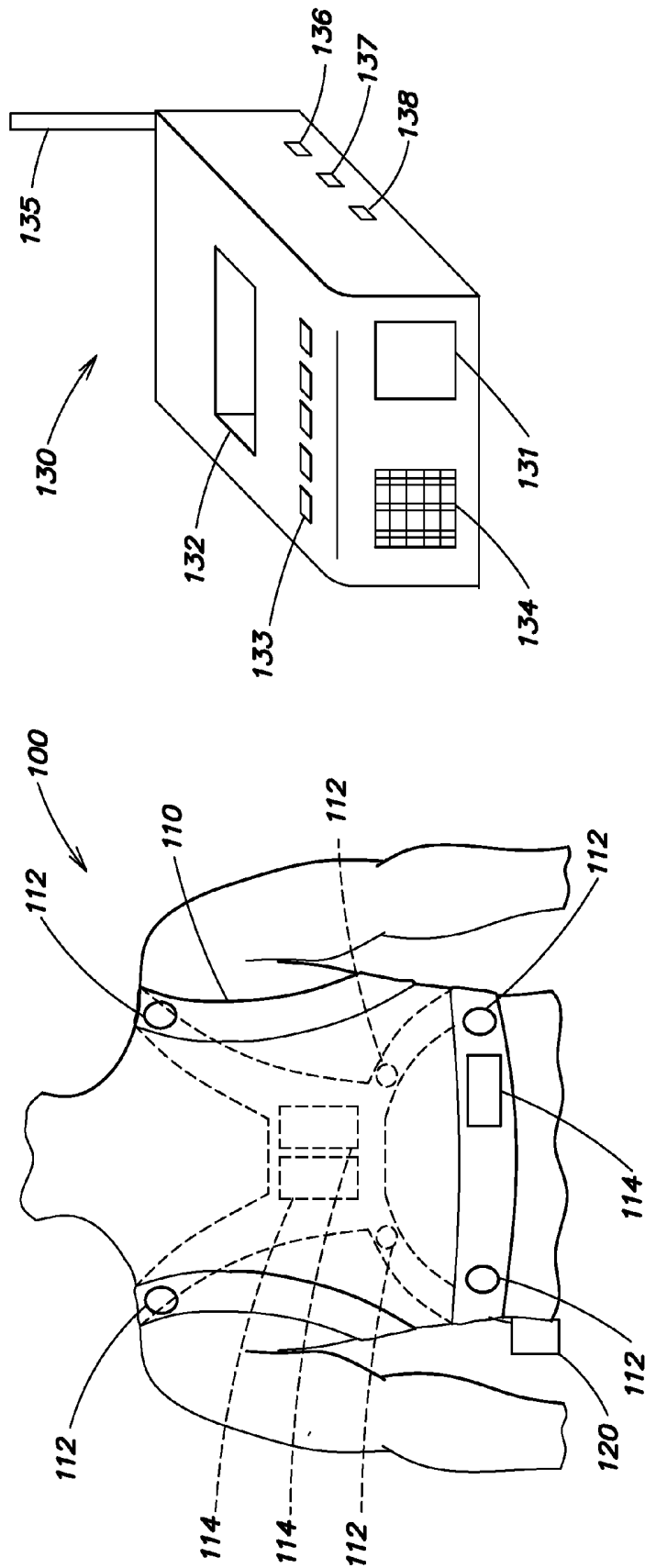

FIG. 1

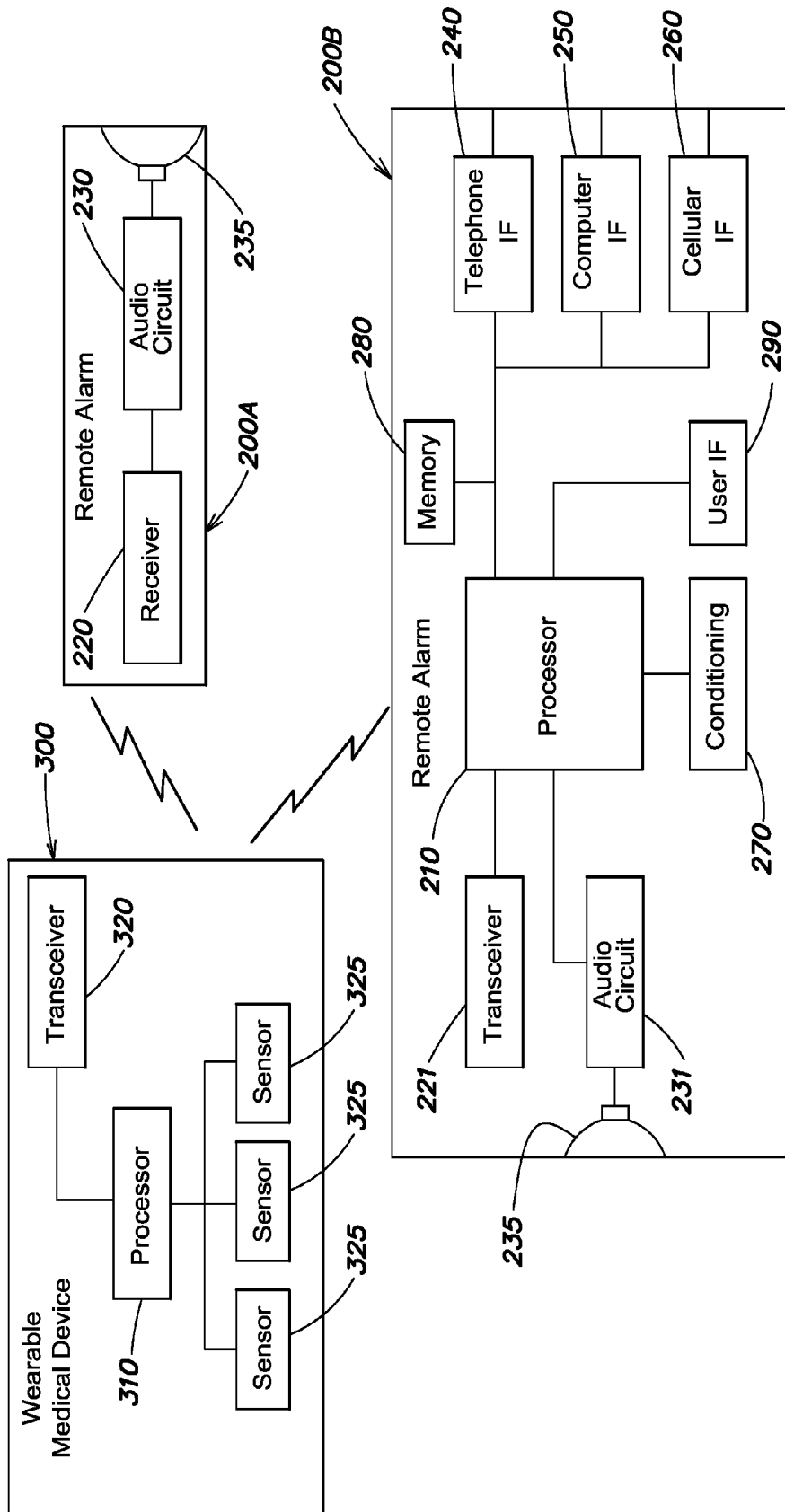

FIG. 2

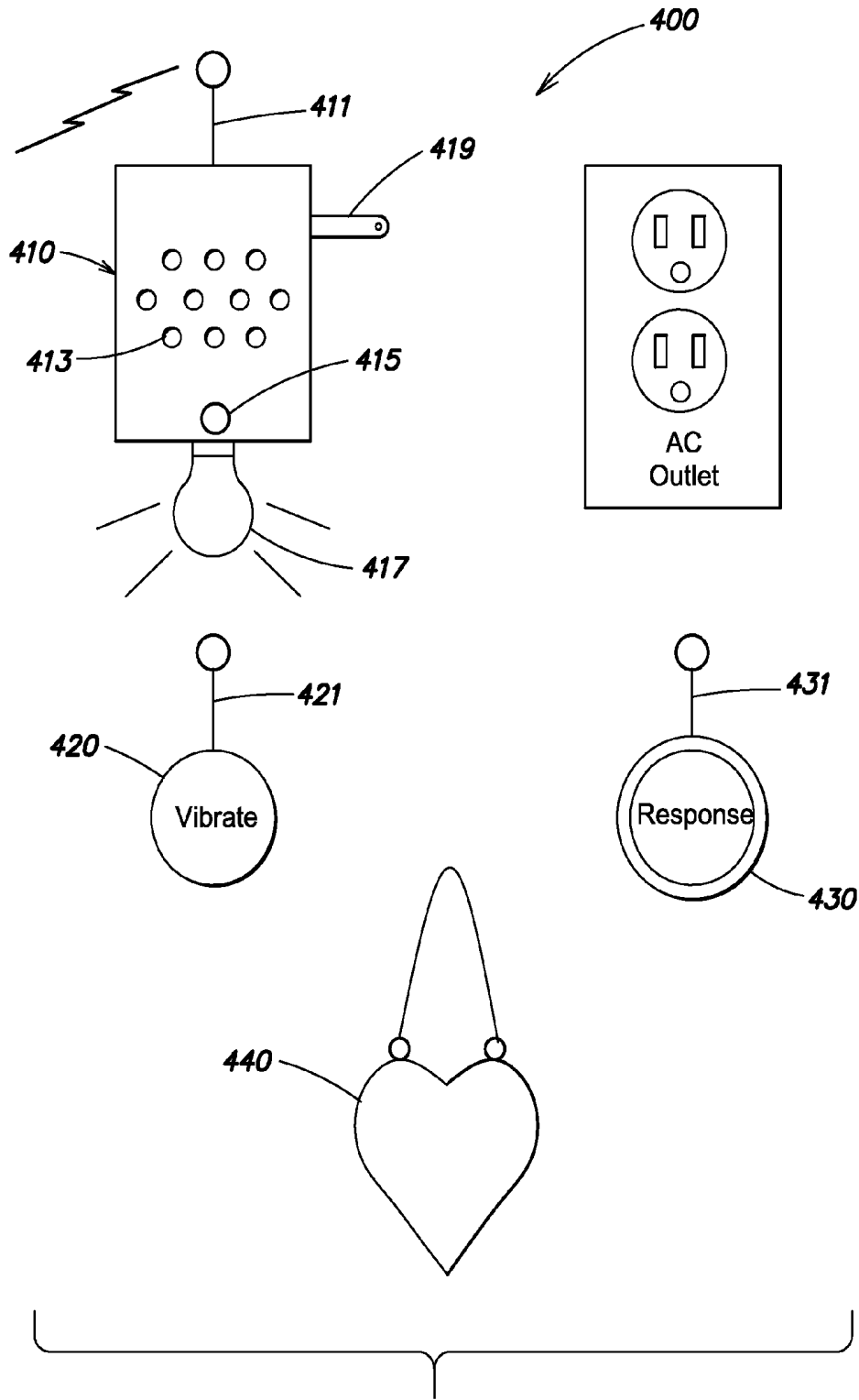

FIG. 3

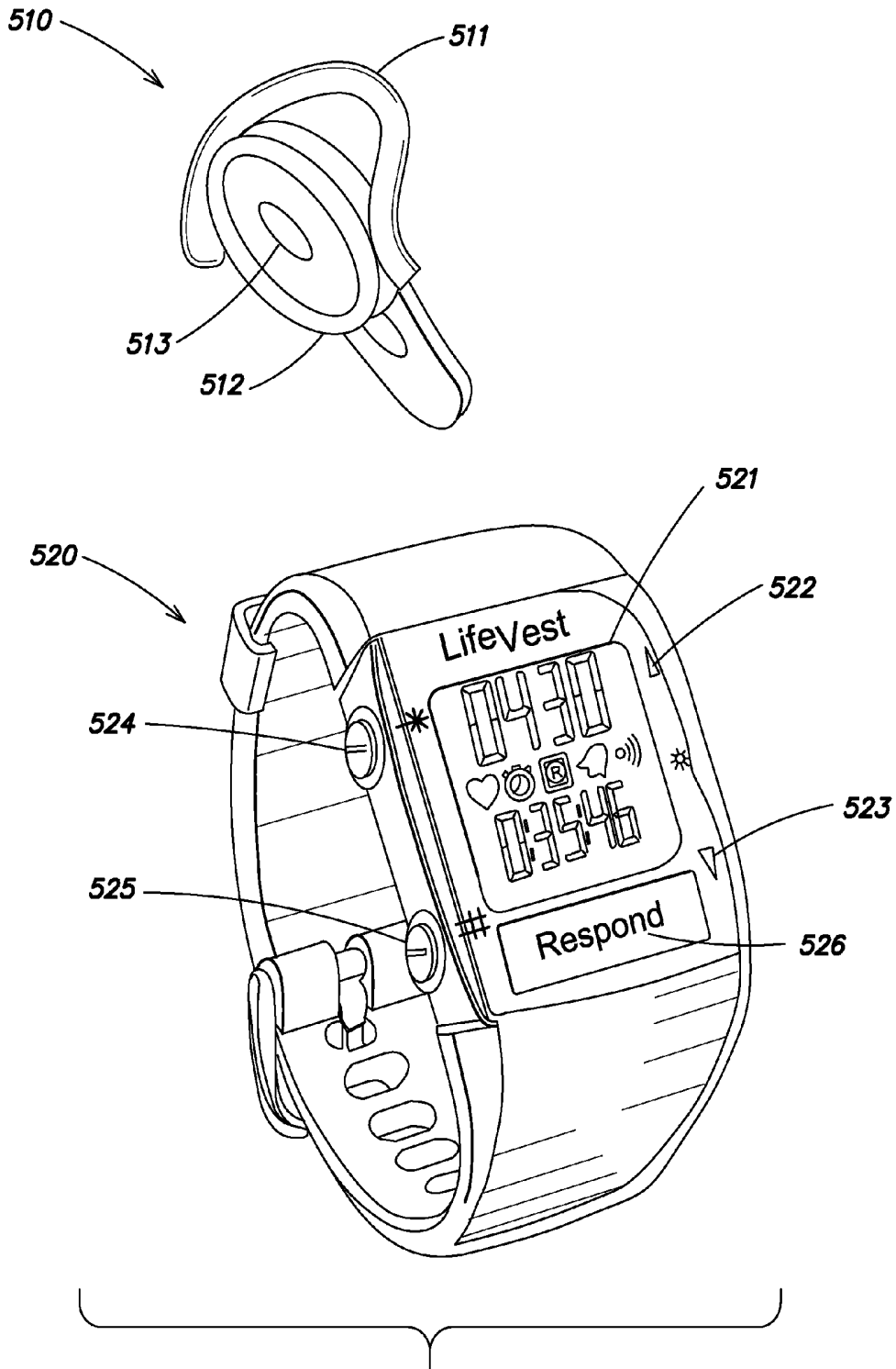

FIG. 4

REMOTE MEDICAL DEVICE ALARMCROSS-REFERENCE TO RELATED
APPLICATIONS

This application claims the benefit under 35 U.S.C. § 120 as a continuation of U.S. application Ser. No. 13/286,533, titled "REMOTE MEDICAL DEVICE ALARM," filed on Nov. 1, 2011, which claims priority under 35 U.S.C. § 119(e) to U.S. Provisional Application Ser. No. 61/411,189 entitled "REMOTE MEDICAL DEVICE ALARM," filed Nov. 8, 2010, which is incorporated herein by reference in its entirety.

BACKGROUND OF THE INVENTION

1. Field of the Invention

The present invention is directed to a remote alarm for use with a wearable medical device.

2. Discussion of Related Art

During the course of use, a wearable medical device, such as a wearable defibrillator, a wearable insulin pump, etc., may issue audible alarms, voice prompts or messages, or visual messages to alert the patient or a bystander to a medical condition, to direct them to take some action to correct a problem, to call for assistance, to request information from the patient or the bystander, or to provide feedback to the device so that the device may continue to function properly. For example, where the wearable medical device is a wearable defibrillator, if the device determines that the patient is experiencing cardiac arrhythmia, the device may issue alarms and voice messages instructing the patient to indicate that they are conscious by pressing and holding a button associated with the device, thereby instructing the device to withhold the delivery of a defibrillating shock. If the patient does not respond, the device may presume that the patient is unconscious, and proceed with the treatment sequence, culminating in the delivery of one or more defibrillating shocks to the body of the patient. Alarms and messages may also be directed to a bystander instructing the bystander to call for medical assistance, or to alert any bystanders that a defibrillating shock is about to be delivered and to stand clear of the patient.

SUMMARY OF THE INVENTION

Applicants have appreciated that there may be circumstances where the alarms and messages may not be received by the patient or bystanders. For example, where the patient is asleep in bed, the patient may be sleeping so soundly that the alarms and voice messages are not loud enough to wake the patient. Alternatively or additionally, the speaker region of the wearable medical device may be blocked or shielded by bedding or an article of clothing, thereby reducing the sound to a level where the patient or bystander does not hear the alarms, voice prompts or messages. Even where the patient may be awake, the patient may be located in a noisy environment, such that they cannot hear the alarms or messages.

According to an aspect of the present invention, a remote alarm is provided for use with a wearable medical device. In accordance with one embodiment, the remote alarm is configured to receive alarms, voice messages and prompts issued by the wearable medical device and to repeat those alarms, voice messages and prompts in a manner that can more easily be perceived by a patient wearing the wearable medical device or a bystander. In accordance with another

embodiment, the remote alarm can be configured to receive a communication from the wearable medical device, and in response to that communication, to identify one or more messages to be provided to the patient or a bystander. The messages may be provided audibly or visually, or both. In certain embodiments, in addition to providing messages to the patient or bystander, the remote alarm may further be configured to take certain actions depending upon the content of the communication, such as sending a telephone message to alert emergency personnel to the identity, location and medical condition of the patient, or sending an email to a friend or relative.

In accordance with one embodiment of the present invention, a remote alarm is provided for use with a wearable medical device. The remote alarm comprises an RF receiver to receive an RF signal indicative of a message to be provided by the wearable medical device, an audio circuit, electrically coupled to the receiver, to convert the message to an audio signal, and an audio display device. The audio display device is electrically coupled to the audio circuit to receive the audio signal and reproduce the message to be provided by the wearable medical device. In accordance with an aspect of this embodiment, the receiver receives the RF signal using one of a Bluetooth, Wireless USB, and a ZigBee communication standard, and the message is a voice message, siren, or tone. In accordance with another aspect of this embodiment, the wearable medical device is a wearable defibrillator. In accordance with a further aspect of this embodiment, the message is reproduced at a greater volume than can be provided by the wearable medical device. In accordance with a further aspect of this embodiment, the remote alarm includes a high intensity light bulb that illuminates in response to receipt of the message.

In one embodiment, the RF receiver, the audio circuit, the audio display device, and the light bulb are integrated into a first device configured to be directly plugged into an AC power receptacle. In a further embodiment, the remote alarm further comprises a second device, distinct from the first device, wherein the second device includes a response button by which a response to the message can be provided, and an RF transmitter to transmit the response to the wearable medical device. In a still further embodiment, the remote alarm may further comprise a third device, distinct from the first device and the second device, the third device including an RF receiver to receive the RF signal indicative of the message to be provided by the wearable medical device, and an electromechanical vibrator configured to vibrate in response to receipt of the message.

In accordance with another embodiment of the present invention, a remote alarm for use with a wearable medical device is provided. The remote alarm comprises an RF transceiver to receive an RF communication from the wearable medical device, a processor, an audio circuit, and an audio display device. The processor is electrically coupled to the RF transceiver to process the communication and to identify a message based upon a content of the communication. The audio circuit is electrically coupled to the processor and configured to convert the message to an audio signal, and the audio display device is electrically coupled to the audio circuit and configured to audibly reproduce the message. In accordance with one aspect of this embodiment, the message may include a text message, and the audio circuit includes a voice synthesizer that is configured to convert the text message to an audio signal, that when reproduced by the audio display device, corresponds to a speech version of the text message.

In accordance with another aspect of this embodiment, the message is a first message, and the remote alarm further comprises at least one communication interface that is electrically coupled to the processor and communicatively coupled to a network. The at least one communication interface is configured to communicate a second message over the network in response to receipt of the communication. In accordance with a further aspect of this embodiment, in response to the content of the communication indicating that a patient wearing the wearable medical device is experiencing a medical condition, the processor is configured to instruct the at least one communication interface to send the second message over the network to emergency personnel. In accordance with an aspect of this embodiment, the at least one communication interface includes at least one of a telephone network interface, a computer network interface, and a cellular network interface. In accordance with another aspect of this embodiment, the processor instructs the at least one communication interface to communicate the second message over the network to emergency personnel responsive to the content of the communication indicating that a patient wearing the wearable medical device is experiencing a medical emergency. In accordance with a further aspect of this embodiment, the second message identifies the patient, a physical location of the patient, and the medical emergency.

In accordance with yet another aspect of this embodiment, the processor further instructs the at least one communication interface to communicate a third message over the network to at least one of a caregiver of the patient and a relative of the patient. In accordance with an aspect of the present invention, the wearable medical device can be a wearable defibrillator.

In accordance with a still further aspect of this embodiment, the remote alarm may include additional circuitry capable of performing other functions, such as a user interface to receive feedback from the patient or a bystander, and a battery charging and conditioning circuit to receive, charge, and condition a rechargeable battery of the wearable medical device. In certain embodiments, feedback received from the patient or a bystander may be transmitted to the wearable medical device. For example, in one embodiment, the remote alarm further comprises a user interface, electrically coupled to the processor. In this embodiment, the user interface is configured to receive a response to the message, and the processor sends the response to the wearable medical device via the RF transceiver in response to receipt of the response to the message by the user interface. In accordance with a further aspect of this embodiment, the message is a first message, and the remote alarm further comprises at least one communication interface that is electrically coupled to the processor and communicatively coupled to a network, the at least one communication interface being configured to communicate a second message over the network in response to receipt of the communication. In accordance with one embodiment, in response to the content of the communication indicating that a patient wearing the wearable medical device is experiencing a medical emergency, and responsive to the remote alarm not receiving any response to the message, the processor instructs the at least one communication interface to communicate the second message over the network to emergency personnel, the second message identifying at least one of the patient, a physical location of the patient, and the medical emergency.

In accordance with one embodiment, the remote alarm includes a clip configured to secure the remote alarm to an ear of a patient wearing the wearable medical device, and in

accordance with another embodiment, the remote alarm includes a strap configured to secure the remote alarm to a wrist of a patient wearing the wearable medical device.

In accordance with another aspect of the present invention, a method of remotely alerting a patient wearing a wearable medical device to a medical condition is provided. The method comprises acts of receiving, on a first device that is distinct from the wearable medical device, a communication from the wearable medical device; processing, on the first device, the communication to identify a message to be communicated to the patient based upon a content of the communication; determining, on the first device, whether the message is to be immediately communicated to the patient; and converting the message to an audio signal and audibly reproducing the message on the first device to alert the patient to the medical condition in response to a determination that the message is to be immediately communicated to the patient.

In accordance with one embodiment, the message is a first message, and the method further comprises acts of waiting, responsive to the act of converting and audibly reproducing the first message, a predetermined period of time for a response to the first message; and communicating, over a communication network to which the first device is communicatively coupled, a second message to at least one of emergency medical personnel, a caregiver of the patient, and a relative of the patient to alert them to the medical condition in response to not receiving the response to the first message within the predetermined period of time.

In accordance with another embodiment, the method further comprises acts of converting the message to a text message in response to a determination that the message is not to be immediately communicated to the patient; storing the text message in a memory of the first device; and setting an indicator on the first device to alert the patient to the stored text message.

In accordance with yet another embodiment, the message is a first message, and the method further comprises an act of sending a second message from the first device to a second device that is distinct from the first device and the wearable medical device, the second message instructing the second device to vibrate in response to receipt of the second message to alert the patient to the medical condition.

Still other aspects, embodiments, and advantages of these exemplary aspects and embodiments, are discussed in detail below. Moreover, it is to be understood that both the foregoing information and the following detailed description are merely illustrative examples of various aspects and embodiments of the present invention, and are intended to provide an overview or framework for understanding the nature and character of the claimed aspects and embodiments. Any embodiment disclosed herein may be combined with any other embodiment in any manner consistent with at least one of the objects, aims, and needs disclosed herein, and references to "an embodiment," "some embodiments," "an alternate embodiment," "various embodiments," "one embodiment," "at least one embodiment," "this and other embodiments" or the like are not necessarily mutually exclusive and are intended to indicate that a particular feature, structure, or characteristic described in connection with the embodiment may be included in at least one embodiment. The appearance of such terms herein is not necessarily all referring to the same embodiment.

BRIEF DESCRIPTION OF THE DRAWINGS

The accompanying drawings are not intended to be drawn to scale. In the drawings, each identical or nearly identical

component that is illustrated in various figures is represented by a like numeral. For purposes of clarity, not every component may be labeled in every drawing. In the drawings:

FIG. 1 illustrates a wearable medical device, such as a wearable defibrillator and an associated base unit;

FIG. 2 is a functional block diagram of remote alarm that may be used with a wearable medical device in accordance with an aspect of the present invention;

FIG. 3 illustrates a remote alarm that may be used with a wearable medical device in accordance with an aspect of the present invention in which the remote alarm includes a number of discrete alarm devices; and

FIG. 4 illustrates several alternative embodiments of a remote alarm in accordance with aspects of the present invention.

DETAILED DESCRIPTION

This invention is not limited in its application to the details of construction and the arrangement of components set forth in the following description or illustrated in the drawings. The invention is capable of other embodiments and of being practiced or of being carried out in various ways. Also, the phraseology and terminology used herein is for the purpose of description and should not be regarded as limiting. The use of “including,” “comprising,” “having,” “containing,” “involving,” and variations thereof herein is meant to encompass the items listed thereafter and equivalents thereof as well as additional items.

FIG. 1 illustrates a wearable medical device **100** and an associated base unit **130**. In the embodiment depicted in FIG. 1, the wearable medical device **100** is a wearable defibrillator, such as a LifeVest® wearable cardioverter defibrillator available from Zoll Medical Corporation of Chelmsford, Mass. As shown, the wearable medical device **100** includes a harness **110** having a pair of shoulder straps and a belt that is worn about the torso of a patient. The wearable medical device **100** includes a plurality of ECG sensing electrodes **112** that are attached to the harness **110** at various positions and electrically coupled to a control unit **120**. The wearable medical device **100** also includes a plurality of therapy electrodes **114** that are electrically coupled to the control unit and capable of delivering one or more therapeutic defibrillating shocks to the body of the patient, if it is determined that such treatment is warranted. Although not shown, the wearable medical device **100** may include additional sensors, other than the ECG sensing electrodes **112**, capable of monitoring the physiological condition or activity of the patient. For example, sensors capable of measuring blood pressure, heart rate, thoracic impedance, pulse oxygen level, respiration rate, heart sounds, and the activity level of the patient may also be provided.

In use, the control unit **120** of the wearable medical device **100** monitors ECG signals provided by the plurality of ECG electrodes **112** and, where provided, some or all of the signals provided by other sensors. Where the control unit **120** determines that the patient is experiencing cardiac arrhythmia, the control unit **120** may issue an audible alarm via a loudspeaker (not shown) on the control unit **120** or on the harness **110** alerting the patient and any bystanders to the patient's medical condition. The control unit **120** may also instruct the patient to press and hold a button (not shown) on the control unit **120** or elsewhere to indicate that the patient is conscious, thereby instructing the control unit **120** to withhold the delivery of one or more therapeutic defibrillating shocks.

As shown in FIG. 1, the wearable medical device **100** may be associated with a base unit **130**. For example, in the LifeVest® wearable cardioverter defibrillator, a base unit **130** is provided that is capable of performing a number of different functions. One of the functions performed by the base unit **130** is to charge an auxiliary battery that is used to provide power to the wearable medical device. The LifeVest® wearable cardioverter defibrillator is provided with two batteries, such that one of the batteries is recharged while the other is providing power to the device. When the battery that is providing power to the device needs recharging, it is swapped with the auxiliary battery, and recharged, with this cycle being repeated throughout the duration of patient usage. Another of the functions performed by the base unit **130** is to store and/or communicate information received from the wearable medical device over a wired or wireless communication network. For example, information relating to the patient's medical condition over a period of time may be communicated by the base unit **130** to a medical service provider, such as a doctor, so that the doctor may remotely monitor the patient's medical condition. The information received by the base unit **130** may be communicated over the network shortly after it is received by the base unit **130**, or alternatively, may be stored in a memory of the base unit **130** and communicated over the network at a later time. The information that is communicated by the base unit **130** may be retained in the memory of the base unit.

The base unit **130** includes a visual display **131** that can communicate visual messages to the patient or a bystander, an audio output device **134**, such as a loudspeaker, that can communicate audible messages to the patient or a bystander, and a plurality of buttons **133** by which the patient or a bystander can communicate with the base unit **130**. In certain embodiments, the visual display **131** may include a touch screen display, such that the patient or a bystander may also communicate with the base unit via the visual display **131**. The base unit **130** includes at least one charging bay **132** to receive a rechargeable auxiliary battery, such as a three cell 2200 mAh lithium ion battery pack, that can be used to provide power to the wearable medical device **100**. The base unit **130** also includes several different communication interfaces including: a device communication interface **138** to receive information from the control unit **120** of the wearable medical device, a telephone network interface **136** to communicate, via a telephone network, the information received from the wearable medical device, and a network interface **137** to communicate, via a wired network connection, the information received from the wearable medical device. In certain embodiments, the base unit **130** also includes an antenna **135** that can wirelessly communicate the information received from the wearable medical device via a cellular (e.g., 2G, 3G, and 4G) network.

FIG. 2 illustrates a remote alarm **200A**, **200B** that may be used with a wearable medical device **300**, such as a wearable defibrillator, a wearable insulin infusion pump, or any other type of wearable medical device in accordance with an aspect of the present invention. The wearable medical device **300** generally includes at least one processor, microprocessor, or controller **310**, such as a processor commercially available from companies such as Texas Instruments, Intel, AMD, Sun, IBM, Motorola, Freescale and ARM Holdings. In one exemplary embodiment directed to a wearable defibrillator, the at least one processor **310** may include a power conserving processor arrangement that includes a general purpose processor, such as an Intel® PXA270 processor and a special purpose processor, such as a Freescale DSP56311 Digital Signal Processor, as described in co-pending U.S.

application Ser. No. 12/833,096, entitled SYSTEM AND METHOD FOR CONSERVING POWER IN A MEDICAL DEVICE, filed Jul. 9, 2010 (hereinafter the “’096 application”) and incorporated by reference herein in its entirety. The at least one processor **310** is electrically coupled to a plurality of sensors **325**, such as ECG sensing electrodes **112** and therapy electrodes **114** (FIG. 1) to monitor the patient’s medical condition, and in some embodiments, to provide medical treatment to the patient in response to a detected medical condition, such as cardiac arrhythmia.

In accordance with an aspect of the present invention, the wearable medical device **300** also includes a wireless Radio Frequency (RF) transceiver **320** that is electrically coupled to the at least one processor **310** and capable of wirelessly and bi-directionally communicating with the remote alarm **200A**, **200B**. In certain embodiments, the wireless RF transceiver **320** may communicate with the remote alarm **200A**, **200B** using a wireless communication standard and protocol that is optimized for low cost and shorter distance (e.g., 10 meters) communications, such as Bluetooth, Wireless USB, or ZigBee. In other embodiments, the RF transceiver **320** may communicate with the remote alarm **200A**, **200B** using a communication standard and protocol capable of communicating over greater distances, such as Wireless Ethernet, or GSM. For example, in one embodiment, the RF transceiver **320** may communicate via wireless Ethernet with a large format display device, such as a television or an Ipad® to display status, alerts or reminders communicated by the wearable medical device. In certain embodiments, where low cost is a concern, or where communication in only one direction is desired, the wireless RF transceiver **320** may be replaced with a wireless RF transmitter capable of transmitting an analog signal. Although the wireless medical device **300** would not be able to receive messages from the remote alarm **200A**, **200B**, this embodiment would still be capable of sending information to the remote alarm over a wireless communication channel as discussed further below.

In accordance with one embodiment of the present invention, the remote alarm **200A**, **200B** may be implemented as a low-cost device with a singular purpose of being a remote bed-side or table-top alarm that is capable of repeating alarms, voice prompts, and messages issued by the wearable medical device. A functional block diagram of such a single purpose, low-cost, remote alarm is identified in FIG. 2 by reference designator **200A**. In an alternative embodiment, the remote alarm **200A**, **200B** may include additional functionality, such as, for example, the ability to receive, charge and condition one or more auxiliary rechargeable batteries, the ability to function as an alarm clock, the ability to receive and store information indicative of the patient’s medical condition, the ability to communicate information, including information indicative of the patient’s medical condition, to a medical service provider, to a friend or relative, or to emergency personnel over a wired, wireless, or telephone network, etc. A functional block diagram of such a multi-function remote alarm is identified in FIG. 2 by reference designator **200B**. Each of these embodiments is now described in detail below.

The remote alarm **200A** includes a wireless RF receiver **220** that is electrically coupled to an audio circuit **230**, which is, in turn, electrically coupled to an audio output device **235**, such as a loudspeaker. The wireless RF receiver **220** is capable of receiving an analog RF signal from the wearable medical device **300** that carries the same information as that which would be provided to audio circuitry included in the wearable medical device. The information received by the RF receiver **220** is provided to the audio circuit **230** that

converts the received information to an audio signal capable of being reproduced by the audio output device **235**. In this embodiment, the remote alarm **200A** simply repeats the same alarms, voice prompts, and voice messages that would be provided by the wearable medical device **300**. However, because the remote alarm **200A** may be placed in a location where it will not be blocked by bedding, clothing, or other obstructions, and because the audio output device can be larger than that on the wearable medical device, the sound emitted by the remote alarm **200A** will be louder than that provided by the wearable medical device **300** and more likely to be heard by the patient or any bystander. It should be appreciated that rather than transmitting an analog RF signal to the remote alarm **200A**, a digital RF signal may be used instead. However, the use of digital communication may require additional circuitry, such as a Digital-to-Analog converter, which may be avoided by using an analog RF transmission where cost is a paramount concern.

The remote alarm **200B** is capable of performing functions in addition to those described with respect to remote alarm **200A**, and may be integrated into a base unit, such as the base unit **130** described with respect to FIG. 1. The remote alarm **200B** includes a processor **210** that is electrically coupled to a wireless RF transceiver **221** and an audio circuit **231**, with the audio circuit **231** being electrically coupled to an audio output device **235**, such as a loudspeaker. The remote alarm **200B** also includes a memory **280**, such as RAM, ROM, or Flash memory that is electrically coupled to the processor **210**. Although the memory **280** is shown as being separate from the processor, it should be appreciated that certain commercially available processors may include the memory on the same integrated circuit as the processor **210**. Moreover, the memory **280** may include other types of memory, such as magnetic disk memory, optical memory, a USB jump drive, etc. The processor **210** may be any general purpose or special purpose processor available from companies such as Texas Instruments, Intel, Sun, AMD, IBM, Motorola, etc.

The wireless RF transceiver **221** is capable of wirelessly and bi-directionally communicating with the wearable medical device **300**, and may include any type of transceiver that is compatible with the communication standard and protocol used by the transceiver **320** of the wireless medical device **300**, such as Bluetooth, Wireless USB, ZigBee, etc. In certain embodiments, where low cost is a concern, or where communication in only one direction is desired, the wireless RF transceiver **221** may be replaced with a wireless RF receiver, such as that described above with respect to remote alarm **200A**, such that the remote alarm **200B** can receive messages and alarms transmitted by the wearable medical device, but cannot send communications back to the wearable medical device **300**. The audio circuit **231** may be any audio circuit capable of providing an audio signal to the audio output device **235**. In certain embodiments, the audio circuit **231** may include a voice synthesizer capable of converting text messages to audible voice messages.

In accordance with certain embodiments of the present invention, the remote alarm **200B** may include additional circuitry to implement additional functionality. For example, the remote alarm **200B** may include a plurality of communication interfaces, such as a telephone network interface **240** by which the remote alarm **200B** can communicate over a telephone network, a wired or wireless computer network interface **250** by which the remote alarm **200B** can communicate over a computer network, and a cellular network interface **260** by which the remote alarm **200B** can communicate over a cellular (e.g., 2G, 3G, 4G) network. Other

circuitry that may be included in the remote alarm **200B** may include a battery recharging and conditioning circuit **270** capable of conditioning and recharging one or more rechargeable batteries that can be used to provide power to the wearable medical device **300**, and a user interface **290**. The user interface **290** may include a visual touch screen display by which the patient or a bystander can communicate with the remote alarm **200B**, and may include a plurality of buttons and/or LEDs, or even a computer keyboard connector for attachment of a computer keyboard to the remote alarm **200B**. The visual touch screen display may function as a clock or as an alarm clock when not otherwise communicating with the patient or a bystander, or alternatively, a separate display may be provided to implement alarm clock functionality.

In accordance with one embodiment of the present invention, the functionality of the remote alarm **200B** may be similar to that provided by the wearable medical device **300**. For example, in one embodiment, the remote alarm **200B** may receive the same information provided to audio circuitry on the wearable medical device **300** and simply repeat those alarms, voice messages, and voice prompts. Where the patient or bystander does not respond, the remote alarm may be programmed to repeat the alarm, voice message, or prompt, but at a louder volume. Such functionality may be sufficient to get the patient's attention, even where the patient is located in a noisy environment, asleep, or both.

In accordance with another embodiment of the present invention, the remote alarm **200B** can be capable of providing feedback to the wearable medical device **300**. For example, in one embodiment, in response to an alarm, voice message or prompt, the patient or a bystander may communicate with the wearable medical device **300** via the user interface **290** on the remote alarm **200B**. The patient could thereby acknowledge that the alarm, voice prompt, or voice message was received by pressing a button on the remote alarm **200B**, or by interacting with the touch screen on the remote alarm. The remote alarm **200B** could then transmit that acknowledgement to the wearable medical device **300** via the transceiver **221**. In certain embodiments, the remote alarm **200B** can include software and/or hardware capable of determining whether the acknowledgement of the alarm, voice prompt, or message is provided by the patient, or by another. For example, the remote alarm **200B** can include voice recognition functionality capable of recognizing the patient's voice, or that of a loved one or caretaker as described in co-pending U.S. patent application Ser. No. 12/082,168, entitled WEARABLE DEFIBRILLATOR WITH AUDIO INPUT/OUTPUT, which is herein incorporated by reference in its entirety. Alternatively, the remote alarm **200B** can include hardware and/or software to recognize biometric information of the patient (or that of a loved one or caretaker), such as capacitance, ECG signals, or markers or ID signals, as described in co-pending U.S. patent application Ser. No. 12/150,720, entitled MEDICAL DEVICE CONFIGURED TO TEST FOR USER RESPONSIVENESS, which is herein incorporated by reference in its entirety.

In accordance with another embodiment of the present invention, the remote alarm **200B** can be capable of providing enhanced communications relative to those afforded by the wearable device **300**. For example, rather than transmitting the same information to the remote alarm **200B** that wearable medical device **300** provides to its audio circuitry, the wearable device **300** could communicate a code to the remote alarm **200B** that corresponds to a particular alarm, message, or prompt stored in a message table in the memory

280 of the remote alarm **200B**. The code transmitted to the remote alarm **200B** could be in analog form, or digital. On receipt of the code, the processor **210** could access the message table and communicate the message to the patient or bystander. The message could be stored in the message table in text form and converted to speech by a voice synthesizer in the audio circuit **231** of the remote alarm **200B**. Alternatively, the message could be displayed in text form on the touch screen display, either alone, or in combination with the message being reproduced audibly. The code could identify the content and/or length of the message, prompt or alarm to be communicated to the patient or bystander, as well as the loudness of the message, and what actions are to be taken in the event of a particular response, or lack of response, from the patient or bystander.

For example, where the wearable medical device **300** is a wearable defibrillator, in the event that the wearable medical device detects a cardiac arrhythmia and the patient does not respond to indicate they are conscious, the remote alarm **200B** can place a phone call to emergency personnel (e.g., 911). The remote alarm **200B** can then play a pre-recorded message that may be stored in the memory **280** to identify the name of the patient, their location, and the detected medical condition. The remote alarm **200B** can also notify the patient's medical service provider to alert them to the patient's condition and that emergency services have been called, and also inform a loved one or relative. The names of the various contacts and the content of the messages to be sent can be stored in the memory **280** of the remote alarm **200B** during a set-up procedure. The patient's medical service provider and the patient's loved one or relative can be sent an email or text message via the wired or wireless computer network interface **250**, or contacted by telephone after notifying emergency personnel using either the telephone network interface **240** or the cellular network interface **260** and playing a pre-recorded message.

Other enhanced communications that may be provided by the remote alarm **200B** can include the ability to communicate messages in different languages. For example, the user interface **290** of the remote alarm **200B** can permit a first language (e.g., the patient's native language) to be selected and used for communicating with the patient, and a second language, different than the first language, to be selected and used for communicating with others, such as bystanders or emergency personnel. Such a feature would be appropriate for those instances where the patient speaks one language, but is physically present in a geographic location where the language spoken by the patient is not native to the geographic location. Where the remote alarm **200B** includes an ability to detect its geographic location (e.g., GPS capability), the remote alarm may automatically configure itself to use the language native to that geographic location for communications directed to a bystander or emergency service personnel.

In accordance with one embodiment, the remote alarm **200B** is capable of communicating various information to the patient, a bystander, a caregiver or a loved one in different ways, depending on the type of information being communicated, or depending on the manner in which the remote alarm is programmed to communicate such information. For example, where the information to be communicated to the patient is of an urgent nature, the remote alarm **200B** may immediately communicate this information to the patient via the audio output device **235**, alone or in combination with other types of notification (e.g., by energizing a vibrating alarm disposed on or near the patient's body as discussed further below). Where the wearable medical

device **300** is a wearable defibrillator, such information that may be considered to be of an urgent nature can include a warning message of imminent shock based upon a detected arrhythmia, a warning message identifying that the rechargeable battery that is powering the wearable medical device **300** is critically low on charge, a warning message that a sufficient number of sensors have fallen off or lost contact with the patient's body such that the patient may not be protected, etc. Where no response is provided by the patient, the remote alarm may increase the volume of the alarm, voice message, or prompt, as well as perhaps notify emergency personnel, a caregiver, or a loved one. Where the patient is mentally impaired, alarms or other messages may be communicated immediately to a caregiver.

Alternatively, where the information to be communicated to the patient is important, but not of an urgent nature, other forms of communication may be more appropriate. For example, where the wearable medical device **300** is a wearable defibrillator and the information to be communicated to the patient corresponds to a detected arrhythmia that abated before a warning message of imminent shock was to be delivered, the remote alarm may simply store the information in the memory **280** and set an indicator (e.g., such as an LED) of the user interface **290** to prompt the patient to interface with the remote alarm **200B** and retrieve that information when next possible. Even where an arrhythmia was detected and a therapeutic shock delivered, the patient may be unaware of this fact. By being prompted to retrieve such information, the patient may be made aware of such events. The occurrence of such events may also be communicated, for example via email, text, or voicemail to the patient, a loved one, a caregiver, or a medical service provider to alert them to the occurrence of the event. Other types of information that may be important but not urgent for a wearable defibrillator to communicate to the patient (or a caregiver) can include a poor signal to noise ratio on one or more sensors (but fewer than a sufficient number of sensors needed to protect the patient), a detected fall-off of one or more sensors (but again, fewer than a sufficient number of sensors), a low battery condition that is not below that needed to monitor and protect the patient, a warning that the harness **110** (FIG. 1) of the wearable medical device may need to be laundered to restore its fit, etc. For other types of wearable medical devices, including defibrillators, messages that are important, but perhaps not urgent, can include reminders about taking medications, a reminder to take a blood glucose reading at a particular time, a reminder to change a battery or a notification that a normal battery replacement or change time has been missed, etc.

In accordance with an aspect of the present invention, the patient or a caregiver may use the user interface to set what types of messages should be communicated immediately versus those that can wait till the next time the patient interacts with the remote alarm. Such settings may be modified based on the time of day and the patient's schedule. For example, those messages that might not be necessary to be communicated immediately when the patient is asleep may be programmed to be communicated immediately where the time of day is such that the user would be awake. Via the user interface, the patient, a caregiver, a medical service provider, or a service technician may set reminders to take medication, reminders to change or recharge a battery, etc., and assign a priority rating to each type of event. Default settings may be provided, that may be altered via the user interface **290**. Other settings may be provided to indicate whether the communication should be audible,

tactile, or both, and whether people other than the patient (e.g., a loved one or caregiver) should be notified.

In accordance with a further aspect of the present invention, information may be pushed to the remote alarm by the patient's caregiver, by the patient's medical service provider, by a loved one, or by a service organization associated with the wearable medical device. For example, where the service organization or manufacturer of the wearable medical device has a message about the device for the patient (e.g., a product recall, a product update, etc.), a message may be pushed to the device for later review by the patient at the next possible timeframe. Alternatively, a message from the patient's medical service provider or a loved one may be pushed to the remote alarm, such as, for example, a reminder about a medical appointment, etc.

Although each of the remote alarms **200A**, **200B** has been described herein as including an RF receiver **220** or transceiver **221** to receive an RF signal from the wearable medical device **300**, it should be appreciated the present invention is not so limited. For example, in an alternate embodiment, the remote alarm may simply include a microphone capable of receiving alarms, voice prompts and messages issued by the wearable medical device and an audio circuit and speaker capable of repeating those alarms, voice prompts and messages, for example, at a louder volume. Alternatively still, the communication between the wearable medical device **300** and the remote alarm **200A**, **200B** could be infrared, audio, or sub-audio. Moreover, although the remote alarms **200A**, **200B** are shown as integrated devices, it should be appreciated that various functionality of the remote alarms **200A**, **200B** may be distributed amongst various individual devices that together provide the described functionality. For example, FIG. 3 illustrates a remote alarm **400** that includes a number of discrete devices **410**, **420**, **430**, and **440** that may collectively operate as a remote alarm. As shown in FIG. 3, in one embodiment, the remote alarm **400** includes an AC receptacle alarm unit **410** that is configured to be plugged directly into a conventional wall power outlet, a vibrating alarm unit **420** that is configured to be placed adjacent to the patient in the patient's bed or armchair, or beneath the mattress of the patient's bed or a seat or back cushion of the patient's armchair, a remote response button **430** that is configured to be placed in any location convenient for the patient, such as on the nightstand next to the patient's bed, or adjacent the patient, and an alarm pendant **440** that is configured to be worn by a loved one or a caregiver of the patient.

As shown in FIG. 3, the AC receptacle alarm unit **410** includes an RF antenna **411** by which it can receive messages from the wearable device **300** and transmit information back to the wearable device. Although not shown, the AC receptacle alarm unit **410** may include a second antenna capable of communicating (e.g., via a cellular or wireless network) with a medical service provider or emergency personnel. The AC receptacle alarm unit **410** also includes an audio output device **413**, such as a loudspeaker, an audio input device **415**, such as a microphone, a light **417**, and a plurality of contacts **419** configured to be received in the wall power outlet. It should be appreciated that the AC receptacle alarm unit may be modified for use with a DC wall outlet. In accordance with an aspect of this embodiment, in response to an urgent message requiring the immediate attention of the patient or another, the AC receptacle alarm unit **410** may not only audibly communicate the message, but may also illuminate the light **417**, which may be a high intensity light bright enough to awaken a sleeping patient (e.g., equivalent in intensity to a **60** watt incandes-

cent bulb, or greater). Although not shown, the AC receptacle alarm unit **410** may include a charging bay capable of receiving and charging an auxiliary battery unit.

The vibrating alarm unit **420** is configured to be placed adjacent the patient, or in any other location (such as beneath a mattress upon which the patient sleeps, or beneath or behind a cushion of an arm chair in which the patient 5
reposes) where its vibration would be likely to alert the patient, if the patient is conscious. The vibrating alarm unit **410** includes an antenna **421** to receive information from the wearable ambulatory device **300** (FIG. 2), and/or the AC receptacle alarm unit **410**, and an electro-mechanical vibrator, such as a piezoelectric vibrator. 10

The remote response button **430** is configured to be disposed in any convenient location where the patient can access the remote response button, and thereby send a signal to the wearable medical device indicating that the patient is conscious. As shown, the remote response button **430** includes an antenna **431** for receiving communications from the wearable medical device or the AC receptacle alarm unit **410**, and for transmitting a signal to the wearable device and/or the AC receptacle alarm unit indicating the patient's consciousness. Although not shown, the remote response button **430** may include an audio output device, such as a loudspeaker, and audio circuitry to repeat the same alarms, voice prompts, and voice messages that would be provided by the wearable medical device. Although the remote response button **430** is described as being one of the discrete devices of the remote alarm **400**, it should be appreciated that both the remote response button **430** and the AC receptacle alarm unit **410** may be used as standalone devices. 20

The alarm pendant **440** is configured to be worn about the neck of a caregiver or loved one, and may light, vibrate, or emit an audible sound alerting the caregiver to check on the patient in the event that an event requiring their attention has been detected. Although not shown, the alarm pendant would also include an RF antenna capable of receiving RF communications, such as Bluetooth, Wireless USB, or Zig-Bee. 25

FIG. 4 illustrates two alternative embodiments of a remote alarm in accordance with aspects of the present invention in the form of an earpiece remote alarm **510** and a watch monitor remote alarm **520**. The earpiece remote alarm **510** includes a clip **511** configured to be disposed about the patient's ear, and a control module **512** that includes an RF transceiver, such as a Bluetooth transceiver. Although not visible, in FIG. 4, the earpiece remote alarm **510** includes an audio output device, such as a speaker configured to be disposed proximate the patient's ear canal for audibly communicating messages received from the wearable medical device **300** to the patient. The earpiece remote alarm may further include a microphone, such that the earpiece remote alarm may additionally act as a hearing aid in which sounds received by the microphone are amplified and conveyed to the patient. As the human ear is considered to be a relatively good location at which to measure the pulse oxygen level of a patient, the earpiece remote alarm **510** may include a pulse oxygen sensor (not shown) that monitors the patient's pulse oxygen level and communicates this information to the wearable medical device **300** (FIG. 2). In some embodiments, the earpiece remote alarm may include a response button **513** by which the patient may indicate their consciousness in response to a detected cardiac arrhythmia and warning of imminent shock. 30

The watch monitor remote alarm **520** resembles an ordinary wristwatch and is configured to be disposed about the patient's wrist using a strap in a conventional manner. The watch monitor remote alarm may, for example, be based upon a watch monitor reference platform, such as the eZ430 Chronos Wireless Watch, available from Texas Instruments. As shown, the watch monitor remote alarm **520** includes a display **521** which can display the date and time, and operate as a conventional wristwatch/alarm using, for example, buttons **524** and **525** for programming the date and time, and setting any alarms. The display **521** can also display informational messages or prompts communicated by the wearable medical device **300** (FIG. 2). For example, as shown in FIG. 4, the display **521** may display a heart symbol to indicate that no arrhythmias are currently detected, and may indicate the state of charge of the battery unit associated with the wearable medical device. Although not shown, the watch monitor remote alarm **520** may include an RF transceiver to receive messages, prompts, and other information from the wearable medical device **300**, and to communicate information back to the wearable medical device. For example, where the wearable medical device detects a cardiac arrhythmia and issues a warning that a shock is imminent, the patient may press and hold a response button **526** to indicate that they are conscious. The watch monitor remote alarm **520** may again include functionality to determine whether the response button **526** was actuated by the patient, or by another. Communication standards supported by the watch monitor remote alarm can include Bluetooth, Wireless USB, ZigBee, as well as wireless Ethernet. The watch monitor remote alarm **520** can include an audio output device (not shown) by which alarms or audible messages may be communicated to the patient. The watch monitor remote alarm may also include sensors (disposed on the back side of the watch and not visible in FIG. 4) to detect the patient's pulse rate, temperature, or blood oxygen level, which may be displayed on the display **521**. Such information may be displayed by using scrolling buttons **522** and **523**. 35

Having thus described several aspects of at least one embodiment of this invention, it is to be appreciated various alterations, modifications, and improvements will readily occur to those skilled in the art. Such alterations, modifications, and improvements are intended to be part of this disclosure, and are intended to be within the scope of the invention. Accordingly, the foregoing description and drawings are by way of example only. 40

What is claimed is:

1. A wearable remote device for use with a wearable defibrillator comprising:
 - a strap for disposing the wearable remote device on a wrist of a patient;
 - a user interface accessible by the patient, a caregiver, a medical service provider or a technician, wherein the user interface is configured to
 - provide settings for indicating whether information received from the wearable defibrillator is to be one of urgently communicated to the patient or not to be urgently communicated to the patient, and
 - provide one or more alarms including at least an alarm indicating a cardiac arrhythmia condition of the patient necessitating a therapy;
 - a processor configured
 - to determine whether the information received from the wearable defibrillator is to be urgently communicated to the patient via the wearable remote device and to which a response from the patient is required,

15

to cause, responsive to determining that the information is to be urgently communicated to the patient via the wearable remote device and to which the response from the patient is required, the wearable remote device to provide an alarm comprising both a vibrational notification to the patient and at least one of an audible and a visual notification to the patient to indicate that the alarm is of an urgent nature, and to cause, responsive to determining that the information is not to be urgently communicated to the patient, the wearable remote device to store the information in a memory for subsequent review;

one or more user response elements that can be actuated by the patient to respond to the alarm communicated to the patient and cause the wearable defibrillator to withhold the therapy that is responsive to the cardiac arrhythmia condition; and

communications circuitry disposed in the wearable remote device;

wherein the wearable defibrillator comprises a controller configured to detect the cardiac arrhythmia condition of the patient based on an analysis of at least one ECG signal obtained from the patient via at least one sensing electrode and to begin a treatment sequence to deliver the therapy via at least one therapy electrode; and

wherein the communications circuitry can wirelessly communicate with the wearable defibrillator to provide information regarding actuation by the patient of the one or more user response elements to the wearable defibrillator to cause the wearable defibrillator to withhold the therapy that is responsive to the cardiac arrhythmia condition.

2. The wearable remote device of claim 1, wherein the wearable defibrillator can be worn about a torso of the patient.

3. The wearable remote device of claim 1, wherein the wearable defibrillator comprises a receiver for receiving wireless communications from the communications circuitry.

4. The wearable remote device of claim 1, wherein the wearable defibrillator comprises a transceiver for wirelessly communicating with the communications circuitry.

5. The wearable remote device of claim 1, wherein the controller of the wearable defibrillator is electrically coupled with the at least one sensing electrode and the at least one therapy electrode of the wearable defibrillator.

6. The wearable remote device of claim 1, wherein the communications circuitry is one of a wireless receiver circuit for wirelessly receiving communications from the wearable defibrillator and a wireless transceiver circuit for wirelessly communicating with the wearable defibrillator.

7. The wearable remote device of claim 1, wherein the communications circuitry comprises a wireless transceiver, and wherein the wireless transceiver is at least one of a radiofrequency transceiver, a BLUETOOTH transceiver, a wireless Ethernet transceiver, a wireless USB transceiver, and a ZIGBEE transceiver.

8. The wearable remote device of claim 1, further comprising a sensor disposed in the wearable remote device, wherein the sensor is at least one of a pulse rate sensor, a body temperature sensor, and a blood oxygen level sensor.

9. The wearable remote device of claim 1, further comprising an audio output device disposed in the wearable remote device, and the processor being in communication with the audio output device, wherein the processor can cause the audio output device to provide an audible message.

16

10. The wearable remote device of claim 1, wherein the one or more user response elements comprise one or more buttons disposed on a housing of the wearable remote device for receiving input from the patient.

11. The wearable remote device of claim 10, the processor being in communication with the communications circuitry, wherein the processor can cause transmission of a patient notification informing the patient to actuate the one or more buttons, and wherein the processor can cause transmission of the information regarding the actuation of the one or more buttons to the wearable defibrillator upon detecting actuation of the one or more buttons.

12. The wearable remote device of claim 1, further comprising a voice synthesizer for converting a text message to an audible message.

13. The wearable remote device of claim 1, further comprising an electromechanical vibrator disposed in the wearable remote device, and the processor being in communication with the electromechanical vibrator, wherein the processor can actuate the electromechanical vibrator to provide the vibrational notification.

14. The wearable remote device of claim 1, further comprising at least one visual indicator disposed on the wearable remote device for providing visual information to the patient.

15. The wearable remote device of claim 14, wherein the visual indicator is at least one of a light bulb and a light-emitting diode (LED).

16. The wearable medical device of claim 14, wherein the at least one visual indicator prompts the patient to interface with the remote alarm and retrieve information stored in the memory.

17. The wearable remote device of claim 1, wherein the wearable defibrillator comprises at least one visual indicator, and wherein the visual indicator is at least one of a light bulb and a light-emitting diode (LED).

18. The wearable remote device of claim 1, the processor being further configured to cause a state of at least one visual indicator to change upon detecting the cardiac arrhythmia condition of the patient.

19. The wearable remote device of claim 1, further comprising a display that can present textual information relating to the patient.

20. The wearable remote device of claim 1, further comprising a display that can present an alarm notification upon detecting the cardiac arrhythmia condition of the patient.

21. The wearable remote device of claim 1, further comprising a user interactive display disposed on a housing of the wearable remote device.

22. The wearable remote device of claim 1, further comprising a display, wherein the display is at least one of an integral part of a housing of the wearable remote device and included within the housing.

23. The wearable remote device of claim 1, the processor being in communication with the communications circuitry, wherein the processor can cause a notification to be issued in response to a predetermined medical condition of the patient.

24. The wearable remote device of claim 23, wherein the notification can be presented on a display of the wearable remote device.

25. The wearable remote device of claim 23, wherein the notification comprises one of an indication that a shock is to be delivered by the wearable defibrillator and an indication that a shock has been delivered by the wearable defibrillator.

26. The wearable medical device of claim 1, wherein the controller is configured to modify settings for the types of information to be communicated urgently and the types of information to be communicated not urgently based on a time of day and the patient's schedule.

27. The wearable medical device of claim 1, wherein the types of information to be communicated urgently and the types of information to be communicated not urgently are provided as default settings that may be altered via the user interface.

28. A wearable remote device comprising:

a user interface accessible by a patient, a caregiver, a medical service provider or a technician;

a strap constructed to removably secure the wearable remote device to a wrist of a patient;

communications circuitry for wirelessly communicating with a wearable defibrillator and configured to receive information from the wearable defibrillator,

wherein the wearable defibrillator comprises a controller configured to detect a cardiac arrhythmia of the patient based on an analysis of at least one ECG signal obtained from the patient via at least one sensing electrode and to begin a treatment sequence to deliver a therapy via at least one therapy electrode;

a processor coupled to the user interface, the processor being configured

to cause the user interface to provide settings for indicating whether the information received from the wearable defibrillator is to be one of urgently communicated to the patient or not to be urgently communicated to the patient, wherein the information that is to be urgently communicated to the patient comprises information relating to the cardiac arrhythmia of the patient necessitating the therapy; to determine whether the information received from the wearable defibrillator comprises information to be urgently communicated to the patient via the wearable remote device and to which a response from the patient is required,

to cause, responsive to determining that the information received from the wearable defibrillator comprises information that is not to be urgently communicated, the wearable remote device to store the information in a memory for subsequent review, and

to cause, responsive to determining that the information received from the wearable defibrillator comprises information relating to the cardiac arrhythmia of the patient necessitating the therapy, the wearable remote device to provide a notification, wherein the notification comprises both a vibrational notification to the patient and at least one of an audible and a visual notification to the patient to indicate that the notification is of an urgent nature; and

at least one user response button disposed on the wearable remote device that can be actuated by the patient to communicate a condition of the patient to the wearable defibrillator in response to the notification relating to the cardiac arrhythmia.

29. The wearable remote device of claim 28, wherein the user interface is at least one of a display, a user interactive display, a button, an audio output device, a light bulb, and an electromechanical vibrator.

30. A wearable remote device comprising:

a user interface accessible by a patient, a caregiver, a medical service provider or a technician;

a strap constructed to removably secure the wearable remote device to a wrist of a patient;

communications circuitry for wirelessly communicating with a wearable defibrillator and configured to receive information from the wearable defibrillator,

wherein the wearable defibrillator comprises a controller configured to detect an arrhythmia condition of the patient based on an analysis of at least one ECG signal obtained from the patient via at least one sensing electrode and to begin a treatment sequence to deliver a therapy via at least one therapy electrode; and

a processor operatively coupled to the user interface, wherein the processor is configured to cause the user interface to provide settings for indicating whether information received from the wearable defibrillator is to be one of urgently communicated to the patient or not to be urgently communicated to the patient, wherein the information that is to be urgently communicated to the patient comprises information relating to the arrhythmia condition of the patient; and

wherein the processor is configured to determine whether the information received from the wearable defibrillator comprises information that is to be urgently communicated to the patient via the wearable remote device and to which a response from the patient is required, wherein, responsive to determining that the information received from the wearable defibrillator comprises information that is to be urgently communicated to the patient via the wearable remote device and to which the response from the patient is required, the processor is further configured to cause the wearable remote device to provide both a vibrational notification to the patient and at least one of an audible and a visual notification to the patient to indicate that the notification is of an urgent nature;

wherein the processor is configured to cause the user interface to receive input from the patient to withhold the therapy relating to the arrhythmia condition of the patient; and

wherein, responsive to determining that the information received from the wearable defibrillator comprises information that is not to be urgently communicated, the processor is further configured to cause the wearable remote device to store the information in a memory for subsequent review.

31. A wearable remote device comprising:

a strap constructed to removably secure the wearable remote device to a wrist of a patient;

communications circuitry for wirelessly communicating with a control unit of a wearable defibrillator and configured to receive information from the wearable defibrillator,

wherein the control unit of the wearable defibrillator is configured to detect an arrhythmia condition of the patient based on an analysis of at least one ECG signal obtained from the patient via at least one sensing electrode and to begin a treatment sequence to deliver a therapy via at least one therapy electrode;

a user interface accessible by a patient, a caregiver, a medical service provider or a technician, wherein the user interface is configured to provide settings for indicating whether information received from the wearable defibrillator is to be one of urgently communicated to the patient or not to be urgently communicated to the patient; and

a processor coupled to the user interface, wherein the processor causes the user interface to provide a notification relating to the arrhythmia condition of the patient necessitating the therapy,

19

the processor being configured
 to cause the user interface to provide settings for
 indicating whether information received from the
 wearable defibrillator is to be one of urgently com-
 municated to the patient or not to be urgently com- 5
 municated to the patient, wherein the information
 that is to be urgently communicated to the patient
 comprises information relating to the arrhythmia
 condition of the patient necessitating the therapy 10
 to determine whether the information received from the
 wearable defibrillator comprises information that is
 to be urgently communicated to the patient via the
 wearable remote device and to which a response
 from the patient is required,
 to cause, responsive to determining that the information 15
 received from the wearable defibrillator comprises
 information that is to be urgently communicated to
 the patient and to which the response from the
 patient is required, the wearable remote device to
 provide both a vibrating notification to the patient

20

and at least one of an audible and a visual notification
 to the patient via the user interface to indicate that the
 notification is of an urgent nature, and
 to cause, responsive to determining that the information
 received from the wearable defibrillator comprises
 information that is not to be urgently communicated,
 the wearable remote device to store the information
 in a memory for subsequent review;
 wherein the wearable defibrillator comprises a harness
 worn about a torso of the patient;
 wherein the user interface is coupled to the strap and
 configured to be accessible to the patient to receive
 input from the patient relating to the arrhythmia con-
 dition; and
 wherein the user interface comprises at least one user
 response element configured to receive the input from
 the patient relating to the arrhythmia condition in
 response to the vibrating notification and the at least
 one of the audible and the visual notification.

* * * * *

专利名称(译)	远程医疗设备报警		
公开(公告)号	US9925387	公开(公告)日	2018-03-27
申请号	US14/579615	申请日	2014-12-22
[标]申请(专利权)人(译)	卓尔医学产品公司		
申请(专利权)人(译)	ZOLL医疗公司		
当前申请(专利权)人(译)	ZOLL医疗公司		
[标]发明人	KAIB THOMAS E VOLPE SHANE S RATTANNI RICHARD A		
发明人	KAIB, THOMAS E. VOLPE, SHANE S. RATTANNI, RICHARD A.		
IPC分类号	G08B1/08 A61N1/39 G08B3/10 A61B5/145 A61B5/024 A61B5/01 A61B5/00 G08B25/10 G08B21/02 G08B25/01		
CPC分类号	A61N1/3993 A61B5/0022 A61B5/01 A61B5/02438 A61B5/14542 A61B5/742 G08B25/10 A61B5/7455 G08B3/10 G08B21/02 G08B21/0277 G08B25/016 A61B5/7405		
代理机构(译)	ZOLL医疗公司		
优先权	61/411189 2010-11-08 US		
其他公开文献	US20150109125A1		
外部链接	Espacenet USPTO		

摘要(译)

用于可穿戴式除颤器的远程警报器。远程警报器可以是可穿戴远程设备，包括用于将可穿戴远程设备设置在患者手腕上的带子和设置在可穿戴远程设备中以与可佩戴除颤器无线通信的通信电路。可穿戴远程设备可以被配置为接收由可穿戴除颤器发出的警报，语音消息和提示，并且以佩戴可穿戴除颤器或旁观者的患者可以更容易地感知的方式重复那些警报，语音消息和提示。可穿戴远程设备还可以被配置为根据通信内容采取某些动作，例如发送电话消息以向紧急人员提醒患者的身份，位置和医疗状况，或者向朋友发送电子邮件，看护人或亲戚。

