



US 20160360986A1

(19) **United States**

(12) **Patent Application Publication**  
**Lange**

(10) **Pub. No.: US 2016/0360986 A1**

(43) **Pub. Date: Dec. 15, 2016**

(54) **WEARABLE DEVICE**  
**ELECTROCARDIOGRAM**

(52) **U.S. Cl.**  
CPC ..... *A61B 5/0402* (2013.01); *A61B 5/1032*  
(2013.01); *A61B 5/04012* (2013.01); *A61B*  
*5/02416* (2013.01); *A61B 5/681* (2013.01)

(71) Applicant: **ChroniSense Medical Ltd.**, Yokneam  
(IL)

(72) Inventor: **Daniel H. Lange**, Kfar Vradim (IL)

(21) Appl. No.: **14/738,636**

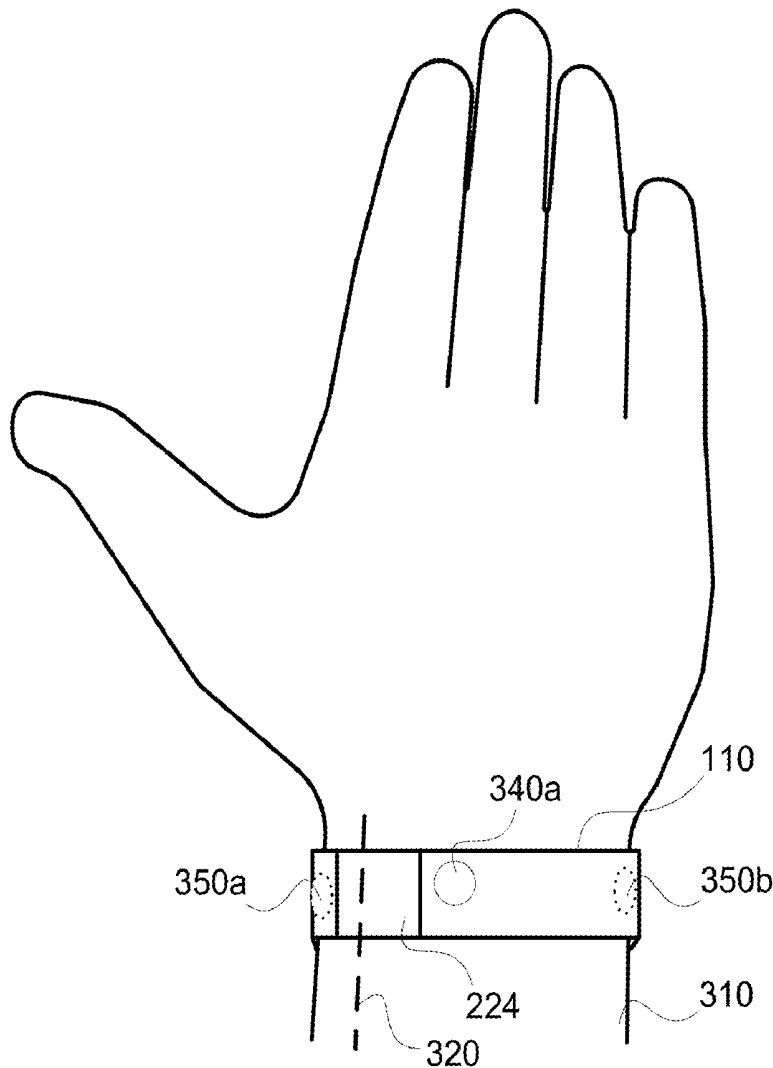
(22) Filed: **Jun. 12, 2015**

(57) **ABSTRACT**

Provided are a method and systems for measuring an electrocardiogram (ECG) using a wearable device. An example system includes the wearable device in a shape of a band worn on a limb (e.g., a wrist) of a patient. The wearable device includes an electrical sensor. The wearable device is operable to record, via the at least one electrical sensor, an electrical signal from the limb of the patient. The wearable device is operable to split the electrical signal into segments based on a reference signal. The reference signal includes an indication of onset times of heart beats. The segments are averaged to derive average ECG data of low signal-to-noise ratio. The wearable device includes an optical sensor operable to measure skin color beneath a pulsating artery of the limb. The reference signal includes a photoplethysmogram (PPG) signal recorded via the optical sensor simultaneously with the electrical signal.

**Publication Classification**

(51) **Int. Cl.**  
*A61B 5/0402* (2006.01)  
*A61B 5/00* (2006.01)  
*A61B 5/024* (2006.01)  
*A61B 5/103* (2006.01)  
*A61B 5/04* (2006.01)



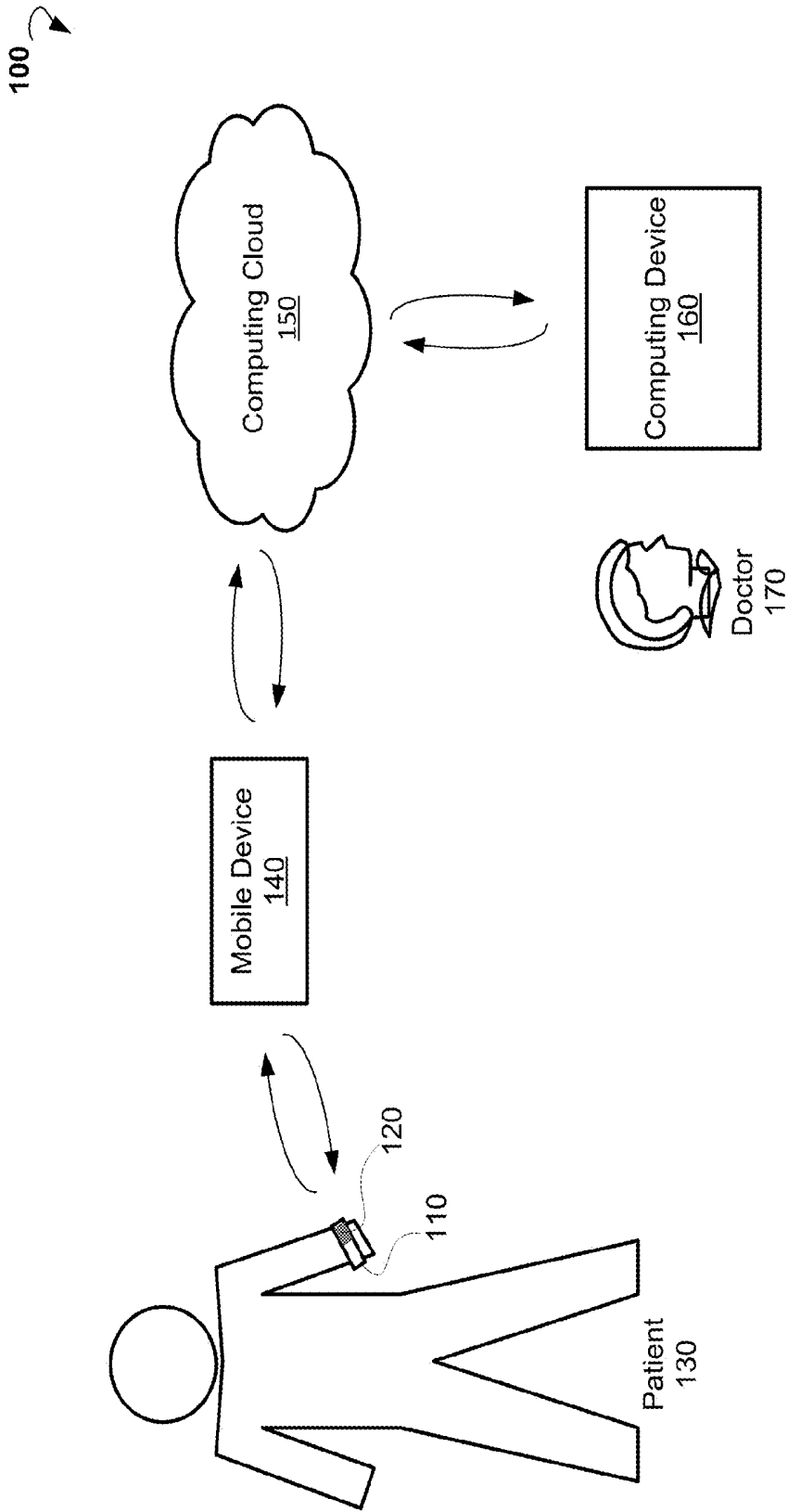
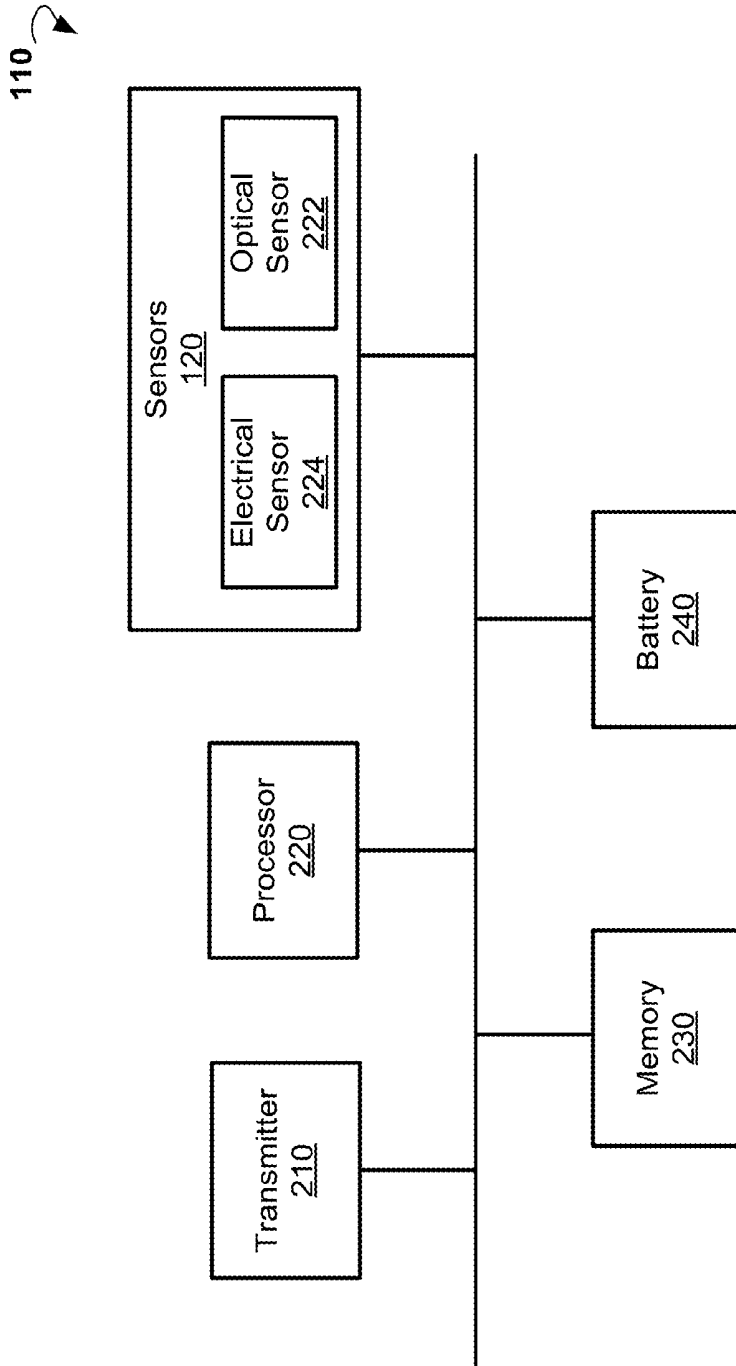
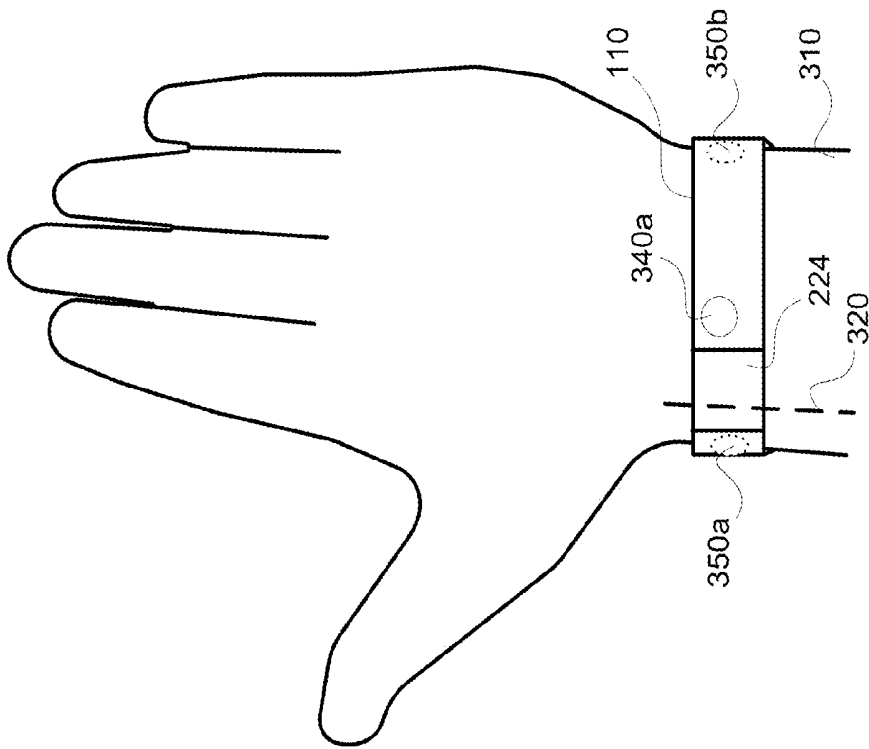


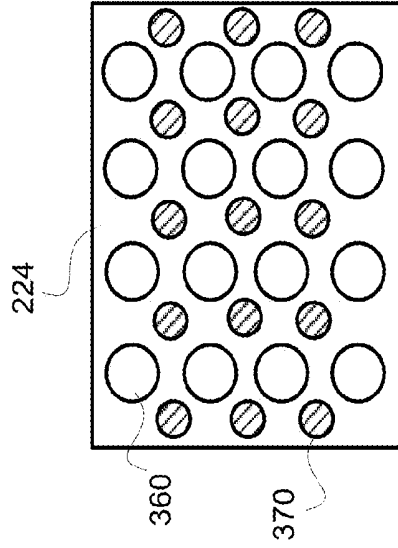
FIG. 1



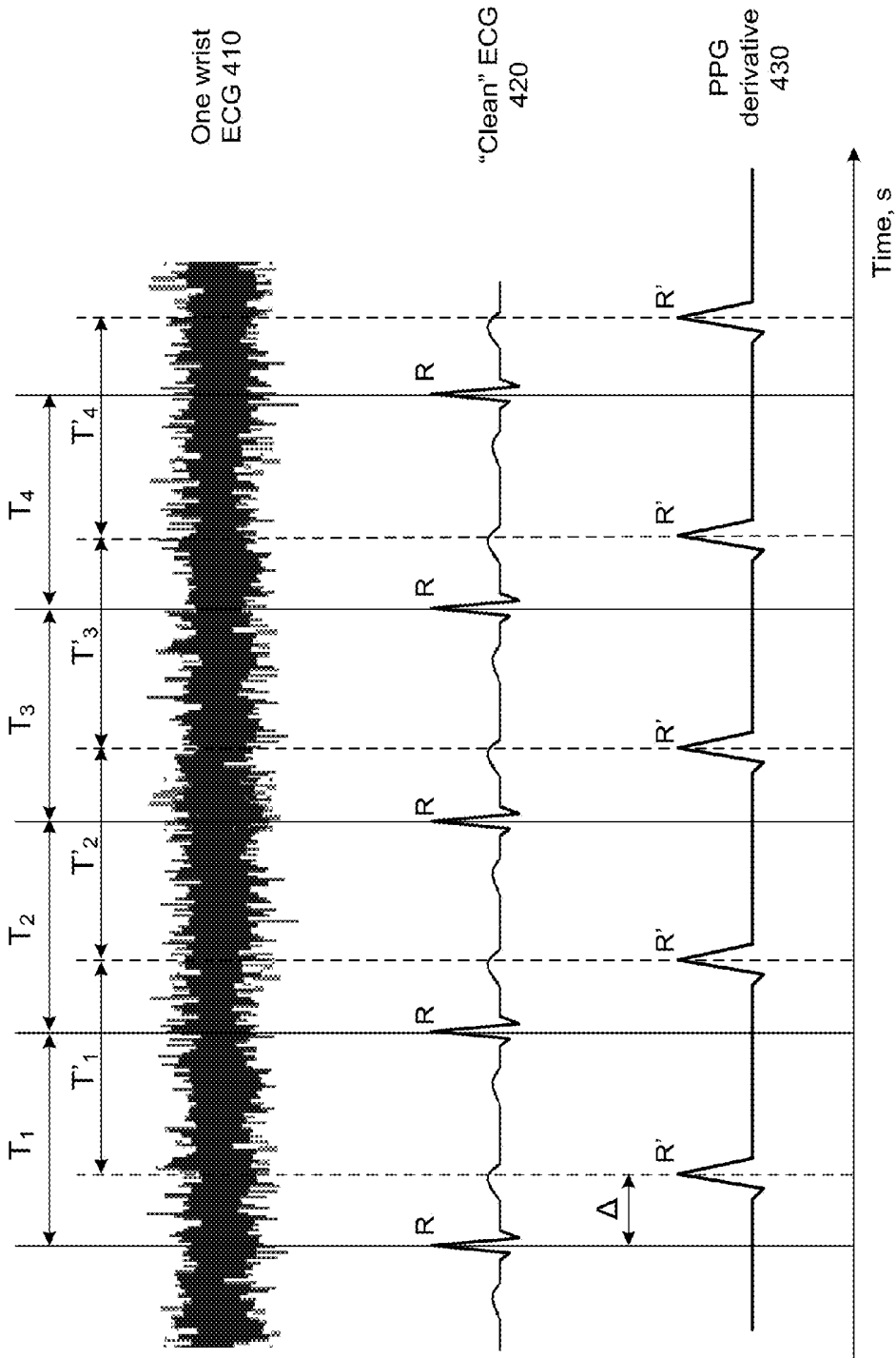
**FIG. 2**



**FIG. 3A**

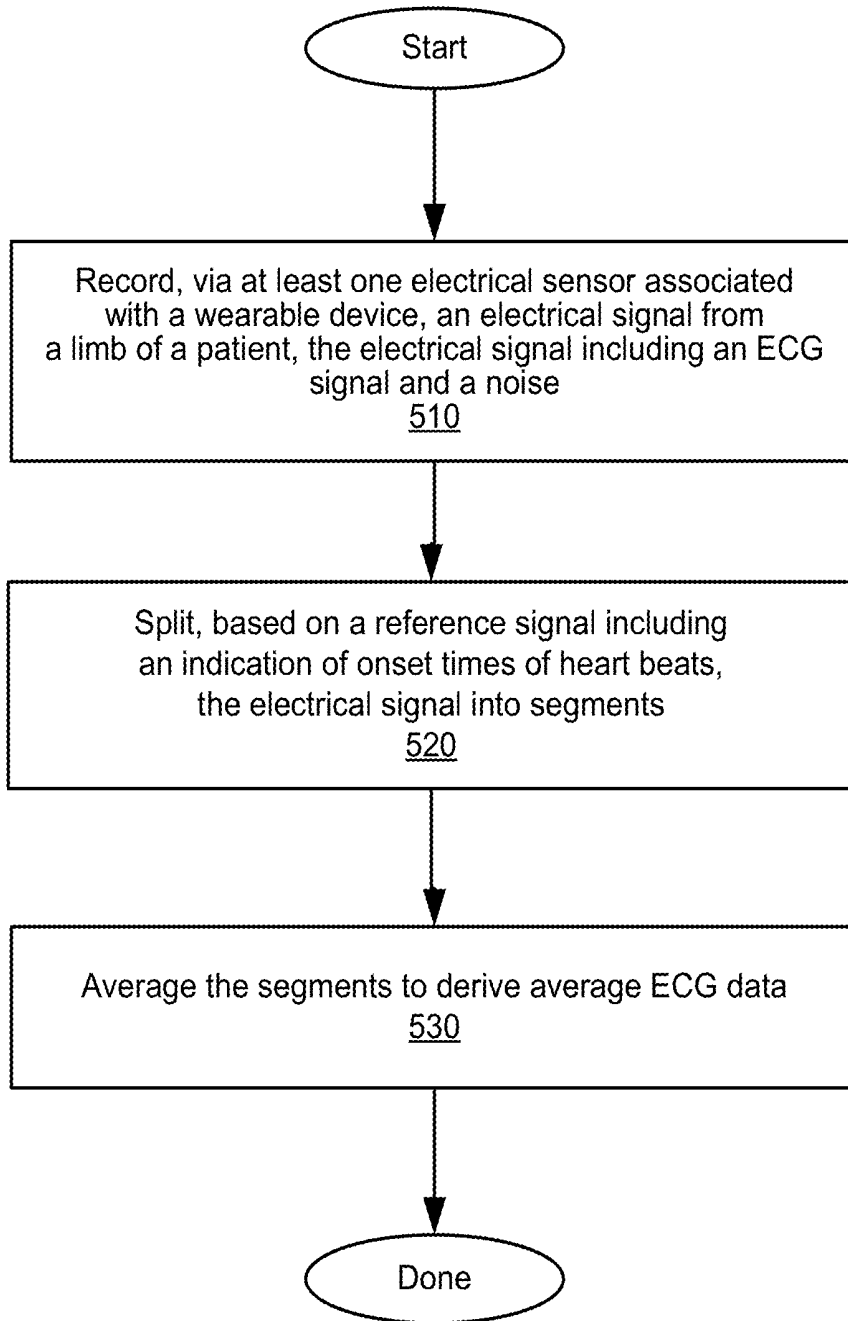


**FIG. 3B**



**FIG. 4**

500 ↻



**FIG. 5**

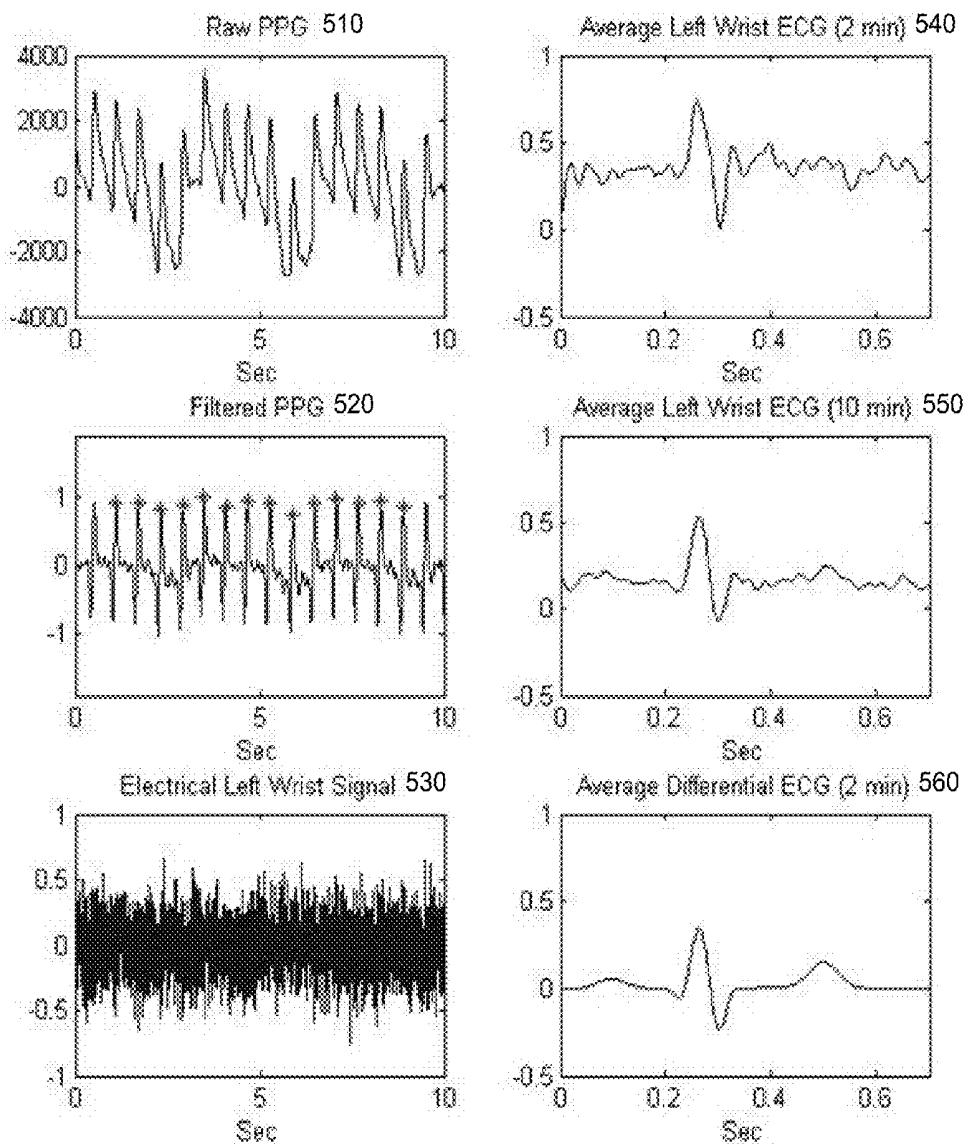


FIG. 6

## WEARABLE DEVICE ELECTROCARDIOGRAM

### CROSS-REFERENCE TO RELATED APPLICATIONS

[0001] The present application is related to U.S. Patent Application titled “Monitoring Health Status of People Suffering from Chronic Diseases” and U.S. Patent application titled “Pulse Oximetry”, both of which are being filed concurrently. The subject matter of the aforementioned applications is incorporated herein by reference for all purposes.

### FIELD

[0002] The present application relates to systems and methods for monitoring health status of people suffering from chronic diseases, and more specifically to measuring an electrocardiogram (ECG) with a wearable device.

### BACKGROUND

[0003] It should not be assumed that any of the approaches described in this section qualify as prior art merely by virtue of their inclusion in this section.

[0004] An ECG represents electrical activity of a heart. Traditionally, an ECG is recorded by placing surface electrodes at multiple locations of a patient’s body (for example, 12 locations in a 12-lead system).

[0005] An ECG is used to measure the heart’s electrical activity, generated by the polarization and depolarization of cardiac tissue, and to translate such electrical activity into an electrical waveform. The ECG waveform can provide information concerning the rate and regularity of heartbeats; size and position of the chambers, and can indicate the presence of damage to the heart muscle. The ECG waveform measurements can be used to analyze the effects of drugs or devices, such as, for example, the effect of a beta-blocker medication on cardiac arrhythmia pathologies, or the effect of a pacemaker, used to regulate the heart.

[0006] The ECG waveform can often detect heart disease, heart attack, an enlarged heart, or abnormal heart rhythms that may cause heart failure. Particularly, certain changes in the ECG waveform may be indicative of life-threatening medical conditions, such as, for example, a myocardial infarction, an acute coronary ischemia, a ventricular hypertrophy, a pulmonary embolism, and so forth.

[0007] In clinical settings, multiple channels can be used to capture different vectors of electrical activity of a beating heart. Monitoring patients out of hospital using a one-lead electrocardiography has proved to provide valuable health status information. Monitoring chronically ill patients outside a hospital environment is crucial for detecting early onset of symptoms and negative progression of chronic diseases.

[0008] Some existing wearable ECG systems include sensing capabilities embedded in vests or shirts. Existing wearable devices wearable are generally designed for measuring heart rates during exercise and do not provide sophisticated analysis of heart activity. Furthermore, while making ECG measurements from a wrist, ankle, or neck is possible, it generally requires closing an electric circuit around the heart using another body part. For example, a patient may be required to close the electric circuit by touching a wrist worn device with the other hand. The requirement of the patient’s

active participation in the measurement process can limit the practical usability of the wearable device.

[0009] Therefore, a need exists to receive ECG measurements using a wearable device without requiring the patient to take an active role in the measurement process.

### SUMMARY

[0010] This summary is provided to introduce a selection of concepts in a simplified form that are further described below in the Detailed Description. This summary is not intended to identify key features or essential features of the claimed subject matter, nor is it intended to be used as an aid in determining the scope of the claimed subject matter.

[0011] According to one aspect of the present disclosure, a system for measuring ECG data using a wearable device is provided. The wearable device can include at least one electrical sensor. The wearable device can be configured to record, via the at least one electrical sensor, an electrical signal from a wrist of a patient. It should be noted, however, that the embodiments of the present disclosure are not limited to the wrist and other parts of a human body such as ankles or neck can be used. The electrical signal can include an ECG signal and a noise. The wearable device can be further operable to split the electrical signal into segments based on a reference signal. The reference signal can include an indication of onset times of heart beats, or other fiducial timing information relating to heart beat. The wearable device can be further operable to average the segments to derive an average ECG data.

[0012] The wearable device can further include an optical sensor. The optical sensor can be operable to measure a color of skin beneath a pulsating artery of the wrist. In certain embodiments, the reference signal is a PPG signal recorded via the optical sensor simultaneously with the electrical signal. In some embodiments, the reference signal is a first derivative of a PPG signal recorded via the optical sensor simultaneously with the electrical signal.

[0013] In various embodiments, prior to the averaging, the segments are distributed into groups. Each group can include segments corresponding to a certain heart rate. The averaging can include averaging segments belonging to at least one of the groups.

[0014] In some embodiments, the electronic sensor includes a first input plate disposed at a proximity of an inner side of a wrist and a second input plate disposed at a proximity of an outer side of the wrist. In certain embodiments, the electronic sensor includes two input plates located on opposite sides of the wrist.

[0015] The wearable device is most commonly embodied in the form of a wristband, a watch, or a bracelet configured to be worn on the wrist. The device may be configured to be worn on any other suitable part of the body of the user.

[0016] The wearable device is configured to analyze average ECG data recorded over an extended period of time to determine trends in parameters of the average ECG data. The wearable device can be further operable to determine, based at least on the trends, at least one possible symptom or a probable progression of at least one chronic heart disease. The wearable device can be configured to provide reports and warning messages regarding the at least one possible symptom and the probable progression. In some embodiments, the segments are intervals between two subsequent heart beats.

[0017] According to another aspect of the present disclosure, a method for measuring an ECG using a wearable device is provided. The method includes recording, via at least one electrical sensor associated with the wearable device, an electrical signal from a wrist of a patient. The electrical signal includes an ECG signal and a noise. The method allows splitting the electrical signal into segments based on a reference signal. The reference signal includes an indication of times at which heart beats occur. The method can also include averaging the segments to derive average ECG data. In some embodiments, the method can further analyze the average ECG data recorded over an extended period of time to determine trends in parameters of the average ECG data. The method can include determining, based at least on the trends, at least one possible symptom or a probable progression of at least one chronic heart disease. The method can also include providing at least one of the following: a report and a warning message regarding the at least one possible symptom and the probable progression.

[0018] According to another example embodiment of the present disclosure, the steps of the method for measuring ECG data using a wearable device are stored on a non-transitory machine-readable medium comprising instructions, which when implemented by one or more processors perform the recited steps.

[0019] Other example embodiments of the disclosure and aspects will become apparent from the following description taken in conjunction with the following drawings.

#### BRIEF DESCRIPTION OF THE DRAWINGS

[0020] Embodiments are illustrated by way of example and not limitation in the figures of the accompanying drawings, in which like references indicate similar elements.

[0021] FIG. 1 is a block diagram showing an example system for measuring ECG data using a wearable device.

[0022] FIG. 2 is a block diagram showing components of an example device for measuring ECG data using the wearable device.

[0023] FIG. 3A is block diagram illustrating an example device for measuring ECG data using the wearable device.

[0024] FIG. 3B is a block diagram showing an example optical sensor.

[0025] FIG. 4 shows example plots of noisy ECG data, a "clean" ECG waveform, and a PPG derivative.

[0026] FIG. 5 is a flow chart showing an example method for measuring ECG data using the wearable device.

[0027] FIG. 6 shows example plots of a raw PPG signal, a filtered PPG signal, an electrical signal from the left wrist, average ECG data from the left wrist, and average differential ECG data.

#### DETAILED DESCRIPTION

[0028] The following detailed description includes references to the accompanying drawings, which form a part of the detailed description. The drawings show illustrations in accordance with exemplary embodiments. These exemplary embodiments, which are also referred to herein as "examples," are described in enough detail to enable those skilled in the art to practice the present subject matter. The embodiments can be combined, other embodiments can be utilized, or structural, logical and electrical changes can be made without departing from the scope of what is claimed.

The following detailed description is, therefore, not to be taken in a limiting sense, and the scope is defined by the appended claims and their equivalents.

[0029] The present disclosure provides systems and methods for measuring ECG data using a wearable device. Embodiments of the present disclosure can allow measuring ECG data of a patient in a non-intrusive manner while, for example, the patient is at home, at work, outdoors, traveling, or is located at some other stationary or mobile environment. Some embodiments of the present disclosure include the wearable device that the patient wears around a wrist. The wearable device allows measuring ECG data from a wrist of the patient without requiring the patient to take an active role in the process. The ECG data collected during an extended period of time can be analyzed to detect and track trends and to make conclusions concerning symptoms and a progression of one or more chronic diseases from which the patient might suffer.

[0030] According to some example embodiments, a method for measuring ECG data using a wearable device includes recording an electrical signal from a patient's wrist. The electrical signal can be recorded via at least one electrical sensor associated with the wearable device. The electrical signal can include an ECG signal and a noise. The method allows splitting the electrical signal into segments. The splitting can be based on a reference signal. The reference signal can include an indication of onset times of heart beats. The method can include averaging the segments to derive average ECG data.

[0031] Referring now to FIG. 1, an example system 100 for measuring ECG data using a wearable device is shown. The system 100 includes at least the wearable device 110. The wearable device can include sensors 120. In some embodiments, the wearable device 110 is worn by a patient 120 (for example, on a wrist) for an extended period of time. The wearable device 110 can be carried out as a watch, a bracelet, a wristband, and the like.

[0032] The wearable device 110 can be operable to constantly collect, via sensors 120, sensor data from a patient 130. Based on the sensor data, the wearable device 110 can be operable to obtain ECG data associated with the patient 130.

[0033] In some embodiments, the system 100 includes a mobile device 140. The mobile device 140 can be communicatively coupled to the wearable device 110. In various embodiments, the mobile device 140 is operable to communicate with the wearable device 110 via a wireless connection such as, for example, Wi-Fi, Bluetooth, Infrared (IR), and the like. The mobile device 140 can include a mobile phone, a smart phone, a phablet, a tablet computer, a notebook, and so forth. The mobile device 140 can be operable to receive the sensors data and analyze the sensor data to generate ECG data.

[0034] In further embodiments, the system 100 may include a cloud-based computing resource 150 (also referred to as a computing cloud). In some embodiments, the cloud-based computing resource 150 includes one or more server farms/clusters comprising a collection of computer servers and is co-located with network switches and/or routers. In certain embodiments, the mobile device 140 is communicatively coupled to the computing cloud 150. The mobile device 140 can be operable to send the sensor data to the computing cloud 150 for further analysis (for example, for extracting ECG data from the sensor data and storing the

results). The computing cloud **150** can be operable to run one or more applications and to provide reports regarding health status of the patient, based on trends in ECG data over time. A doctor **170** treating the patient may access the reports (for example, via computing device **160**) using the Internet or a secure network. In some embodiments, the results of the analysis of the medical parameters can be sent back to the mobile device **140**.

**[0035]** FIG. 2 is a block diagram illustrating components of wearable device **110**, according to an example embodiment. The example wearable device **110** includes sensors **120**, a transmitter **210**, a processor **220**, memory storage **230**, and a battery **240**. The wearable device **110** may comprise additional or different components to provide a particular operation or functionality. Similarly, in other embodiments, the wearable device **210** includes fewer components that perform similar or equivalent functions to those depicted in FIG. 2.

**[0036]** The transmitter **210** can be configured to communicate with a network such as the Internet, a Wide Area Network (WAN), a Local Area Network (LAN), a cellular network, and so forth, to send data streams (for example sensor data, ECG data, and messages).

**[0037]** The processor **220** can include hardware and/or software, which is operable to execute computer programs stored in memory **230**. The processor **220** can use floating point operations, complex operations, and other operations, including processing and analyzing sensor data, to extract ECG data.

**[0038]** In some embodiments, the battery **240** is operable to provide electrical power for operation of other components of the wearable device **110**. In some embodiments, the battery **240** is a rechargeable battery. In certain embodiments, the battery **240** is recharged using an inductive charging technology.

**[0039]** In various embodiments, the sensors **120** include at least one electrical sensor **224** and at least one optical sensor **222**. In certain embodiments, the sensor **120** can include position and motion sensors. The motion sensors can include an accelerometer, gyroscope, and Inertial Measurement Unit (IMU).

**[0040]** FIG. 3A is a block diagram illustrating an example wearable device **110** placed around the left wrist of a patient. In the example of FIG. 3A, the wearable device **110** is carried in a shape of a watch, a ring and/or a bracelet.

**[0041]** The electrical sensor **224** can include a differential amplifier operable to measure the electrical signal from the wrist. The electrical sensor **224** can include two active amplifier input plates embedded in the wearable device at opposite ends. In some embodiments, the first input plate (not shown) can be placed above the outer side of the wrist, and the second input plate **340a** can be placed beneath the inner side of the wrist. Alternatively or additionally, in other embodiments, the input plates **350a** and **350b** can be placed in contact with, respectively, the left and right sides of the wrist.

**[0042]** In some embodiments, the optical sensor **224** can be placed beneath a pulsating artery travelling along the arm and into the wrist **310**. In some embodiments, the radial artery **320** passing in the inner wrist is used for measurements by the optical sensor **222**. In other embodiments, other arteries such as the ulnar artery may be used. An external light source generating constant lighting can be used to radiate the pulsating artery. A beam reflected from

the pulsating artery can be intercepted by the optical sensor **222**. In certain embodiments, red lighting is used to radiate the pulsating artery. Alternatively, in other embodiments, other lighting, for example white lighting, can be used.

**[0043]** FIG. 3B is a block diagram showing an optical sensor **222**, according to an example embodiment. The optical sensor **222** can include multiple light sensors **360** (for example, photoelectric cells) to measure the reflected light. The pulsating artery can be irradiated by multiple light transmitters **370** (for example, Light Emission Diodes (LEDs)). The number and location of the light sensors and light transmitters can be chosen in a way that if, accidentally, the wearable device **110** slides off, at least one of the light sensors is still located sufficiently close to the pulsating artery. In some embodiments, when measuring the light reflected from the pulsating artery, a signal from those photoelectric cells that provides the strongest output can be selected for further processing.

**[0044]** FIG. 4 shows plots of an example electrical signal **410** measured from one wrist (or some other limb), an example plot of “clean” ECG signal **420**, and a plot of first derivative **430** of a PPG signal. The electrical signal can be recorded with electronic sensor **224** using input plates placed on the wearable device **110**. Taking measurement from a single hand or a single wrist can be challenging because the difference in voltages between measured locations is miniscule. The electrical signal **410** measured at the wrist can include an ECG signal and a noise. The noise can be caused by muscle activity, patient movements, and so forth. The noise component can be larger than the ECG signal. In some embodiments, the signal-to-noise ratio (SNR) is in the range of  $-40$  dB to  $-60$  dB.

**[0045]** The “clean” ECG signal **420** is an imaginary ECG signal that can be obtained simultaneously with electrical signal **410** using a regular two leads ECG recording, for example, when two input plates of a cardiograph are placed at two different wrists of the patient. The “clean” ECG signal **420** can include R peaks corresponding to heart beats. Using the “clean” ECG signal **420** as a reference, the electrical signal **410** can be split in segments, with each of the segments  $T_i$  corresponding to one RR interval (an interval between two successive heart beats). Each segment  $T_i$  of an electrical signal can contain an ECG signal  $s_i(t)$  and a noise component  $e_i(t)$ . Assuming a stationary heartbeat waveform, if segments  $T_i$  are substantially of the same length, then signal  $s_i(t)$  is substantially of the same waveform when noise components  $e_i(t)$  are not correlated to each other. The following averaging technique can be used to extract a ECG signal  $S(t)$  from electrical signal **410**:

$$S(t) = \sum_{i=1}^p (s_i(t) + e_i(t)),$$

wherein  $p$  is a number of segments  $T_i$  selected for averaging. The segments  $T_i$  selected for averaging are measured for a pre-determined time period (for example, for a few seconds or a few minutes). The segments selected for averaging are substantially of the same length.

**[0046]** The averaging increases the SNR in resulting average signal  $S(t)$ . In certain embodiments, the SNR in resulted averaged signal  $S(t)$  can be further increased by weighted averaging, Wiener filtering, Adaptive filtering, and with other techniques.

**[0047]** Since the “clean” ECG signal **420** is not available when the measurements are carried out on a single wrist, a PPG signal can be used as a reference signal to split the

electrical signal **410** in segments. In various embodiments of the present disclosure, the PPG signal is recorded using the optical sensor **222** simultaneously with the electrical signal **410**, which is recorded by the electrical sensor **224**. The PPG signal is obtained by sensing a change in the color of skin. The change of the skin color is caused by a blood flow in the pulsating artery. In some embodiments, the first derivative of PPG **430** can be used as a reference signal. The first derivative PPG **430** can include sharp peaks R' corresponding to the heart beats. Since it takes a time for blood to flow from the heart to the wrists, the peaks R' are shifted by a time period A relative to the heart beats R in "clean" ECG signal **420**. Assuming that A is approximately the same for all heart beats, the peaks R' can be used to split the electrical signal **410** in segments  $T_i$ . In some embodiments, the averaging technique can be applied to segments  $T_i$  of ECG data to increase SNR. In other embodiments, the segments  $T_i$  can be shifted by the time period A and the averaging can be applied to the shifted segments.

[0048] In some embodiments, prior to the averaging, the segments of the ECG signal can be split into groups. Each of these groups can include segments of the ECG signal corresponding to a certain pulse rate at which the segments were measured. The pulse rate is provided based on measurements of the PPG signal. The averaging can be applied to each group of segments independently.

[0049] In some embodiments, averaging can be performed on ECG data collected within a pre-determined period of time (for example, during a day). The average ECG data that is obtained by averaging segments collected during a day can be further compiled and saved locally (in the memory of wearable device **110** or mobile device **140**) or remotely (in a memory storage of computing cloud **150**) for further analysis. The average data can be analyzed to detect and track changes and trends in average ECG data over an extended period of time. The extended period of time can include one or more weeks, one or more months, or even years.

[0050] In some embodiments, based at least on the trends, symptoms of one or more chronic diseases are indicated due to their relationship with measured or derived parameters. In certain embodiments, reports concerning suspected progression of one or more chronic diseases can be generated based on the trends. In some embodiments, based on the symptoms, the patient can be advised to take palliative steps such as taking a medication and/or to contact a medical professional.

[0051] In various embodiments, processing electrical signal **410** and first derivative of PPG **430**, analyzing average ECG data to detect and track trends, and generating reports on symptoms and progression of chronic diseases can be performed locally on wearable device **110** and/or mobile device **140** and remotely in computing cloud **150**.

[0052] It may be desirable to utilize the motion data obtained via the motion sensors to provide parameters of body movement and tremor. In certain embodiments the motion data can be used for performing a noise analysis to remove artifacts in ECG data.

[0053] In further embodiments, an accelerometer (a tri-axis accelerometer) can be placed on skin near an artery of the patient and provide data on flexion of the artery due to blood flow. The data provided by the accelerometer can be used to generate the ECG data.

[0054] The wearable device **110** can be configured to operate in at least two modes. A first mode can include reading an ECG data from one wrist, synchronizing the ECG data with reference PPG data, segmenting and grouping the ECG data to perform averaging ECG data to improve the SNR.

[0055] In a second mode, the wearable device can be configured to improve the PPG data based on ECG data as a reference signal. While operating the wearable device in the second mode, the patient can be asked to touch the wearable device with other hand, in order to allow receiving a "two-handed" ECG data (good quality ECG data) which include much less noise than "a single wrist" ECG data. The wearable device can include an extra lead to receive input from other hand when touching. In the second mode, poor PPG data can be segmented using the "two-handed" ECG data as a reference signal. The PPG segments can be dropped and averaged to receive high quality PPG data. The high quality PPG data can be used along with good quality ECG data to estimate, for example, a pulse travel time.

[0056] In some embodiments, the system **100** for measuring ECG data includes at least one additional wearable device. The additional wearable device can be identical to the wearable device **110**. In some embodiments, patient **130** may wear one of the devices throughout the day and another device at nighttime. In certain embodiments, the wearable device can be changed when the battery level drops below a certain level. The wearable device that is not in use at the moment can be recharged. In some further embodiments, the device can be recharged using induction charging technology. In some embodiments, since both the devices are in communication with mobile device **140**, the replaced device can, at least partially, transmit recorded information (ECG data and PPG data) to the replacing wearable device for synchronization. The information can be downloaded to the mobile device **140** and the mobile device **140** can be operable to send the information to the replacing device. Additionally in other embodiments, the two wearable devices can be configured to exchange information (for example ECG data and PPG data) via the computing cloud **160**.

[0057] FIG. 5 is a flow chart of a method **500** for measuring ECG data from using a wearable device, according to an example embodiment. In block **510**, method **500** includes recording an electrical signal from a wrist of a patient. The electrical signal can be recorded by at least one electrical sensor associated with the wearable device. The wearable device can be carried out in a shape of a watch, a bracelet, or a wristband configured to be worn on the wrist of the patient. The electrical signal includes an ECG signal and a noise.

[0058] In block **520**, the method can include splitting the electrical signal into segments based on a reference signal. The reference signal can include an indication of onset times of heart beats. In some embodiments, the reference signal includes a PPG signal recorded via an optical sensor associated with the wearable device simultaneously with the electrical signal. In certain embodiments, the reference signal is the first derivative of a PPG signal recorded via the optical sensor simultaneously with the electrical signal. The optical sensor can be configured to measure color of skin beneath a pulsating artery of the wrist.

**[0059]** In block **530**, the method **500** proceeds to average the segments and to derive average ECG data. Averaging the segments improves the SNR in the electrical signal.

#### EXAMPLE

**[0060]** FIG. 6 illustrates plots of a raw PPG signal (optical signal) **510**, a filtered PPG signal **520**, an electrical signal **530**, average ECG signals **540** and **550**, and an average differential ECG signal **560**. Recordings of the electrical signal **530** and a raw PPG signal **510** can be simultaneously measured at a wrist of a patient. The electrical signal **530** can be measured using a differential amplifier, and the optical signal can be measured with a photodiode detector placed beneath the radial artery. The raw PPG (optical) signal **510** can be processed to receive filtered PPG signal **520**, yielding trigger points for the time-locked averaging of the ECG signal.

**[0061]** According to example measurements, an average 5 minute ECG signal and 15 minute average ECG signal are shown to converge to a two-sided average ECG signal. The two-sided average ECG signal is measured from both sides (for example, from two different wrists of patient). The ECG complex is already evident in a 5 minute average, yet a 15 minute recording provides a higher quality average waveform.

**[0062]** The present technology is described above with reference to example embodiments. Therefore, other variations upon the example embodiments are intended to be covered by the present disclosure.

What is claimed is:

1. A system for measuring an electrocardiogram (ECG) using a wearable device, the system comprising:

the wearable device including at least one electrical sensor, the wearable device configured to:

record, via the at least one electrical sensor, an electrical signal from a limb of a patient, the electrical signal including an ECG signal and a noise;

split, based on a reference signal including an indication of onset times of heart beats, the electrical signal into segments; and

average the segments to derive average ECG data.

2. The system of claim 1, wherein the wearable device further includes an optical sensor, the optical sensor being operable to measure a color of skin beneath a pulsating artery of the limb.

3. The system of claim 2, wherein the reference signal is a photoplethysmogram signal recorded via the optical sensor simultaneously with the electrical signal.

4. The system of claim 2, wherein the reference signal is the first derivative of a photoplethysmogram signal recorded via the optical sensor simultaneously with the electrical signal.

5. The system of claim 1, wherein:

prior to the averaging, the segments are distributed into groups, each group including segments corresponding to a certain heart rate; and

the averaging includes averaging segments belonging to at least one of the groups.

6. The system of claim 1, wherein the at least one electronic sensor includes a first input plate located at an inner side of the limb and a second input plate located at an outer side of the limb.

7. The system of claim 1, wherein the at limb includes one or more of the following a wrist, an ankle, and a neck.

8. The system of claim 1, wherein the wearable device is carried out in a shape of one of the following: a wristband, a watch, and a bracelet configured to be worn on the limb.

9. The system of claim 1, wherein the wearable device is further configured:

to analyze average ECG data derived over an extended period of time to determine trends in parameters of the average ECG data;

determine, based at least on the trends, at least one possible symptom or a probable progression of at least one chronic heart disease; and

provide reports and warning messages regarding the at least one possible symptom and the probable progression.

10. The system of claim 1, wherein the segments are of a length of an interval between two subsequent heart beats.

11. A method for measuring an electrocardiogram (ECG) using a wearable device, the method comprising:

recording, via at least one electrical sensor associated with a wearable device, an electrical signal from a limb of a patient, the electrical signal including an ECG signal and a noise;

splitting, based on a reference signal including an indication of onset times of heart beats, the electrical signal into segments; and

averaging the segments to derive average ECG data.

12. The method of claim 11, wherein the wearable device includes an optical sensor, the optical sensor being operable to measure a color of a skin above a pulsating artery of the limb.

13. The method of claim 12, wherein the reference signal includes a photoplethysmogram signal recorded via the optical sensor simultaneously with the electrical signal.

14. The method of claim 12, wherein the reference signal is the first derivative of a photoplethysmogram signal recorded via the optical sensor simultaneously with the electrical signal.

15. The method of claim 11, further comprising:

prior to the averaging, distributing the segments into groups, each group including segments corresponding to a certain heart rate; and

wherein the averaging includes averaging segments belonging to at least one of the groups.

16. The method of claim 11, wherein the at least one electronic sensor includes a first input plate located on an inner side of the limb and a second input plate located on an outer side of the limb.

17. The method of claim 11, wherein the at least one electronic sensor includes two input plates located on opposite sides of the limb.

18. The method of claim 11, wherein the wearable device is carried out in a shape of one of the following: a wristband, a watch, and a bracelet configured to be worn on the limb.

19. The method of claim 11, further comprising:

analyzing average ECG data derived over an extended period of time to determine trends in parameters of the average ECG data;

determining, based at least on the trends, at least one possible symptom or a probable progression of at least one chronic heart disease; and

providing at least one of a report and a warning message regarding the at least one possible symptom and the probable progression.

20. A non-transitory computer-readable storage medium having embodied thereon instructions, which when executed by a processor, perform steps of a method, the method comprising:

recording, via at least one electrical sensor associated with a wearable device, an electrical signal from a limb of a patient, the electrical signal including an electrocardiogram ECG signal and a noise;

splitting, based on a reference signal including an indication of onset times of heart beats, the electrical signal into segments; and

averaging the segments to derive average ECG data.

\* \* \* \* \*

专利名称(译)	可穿戴设备心电图		
公开(公告)号	<a href="#">US20160360986A1</a>	公开(公告)日	2016-12-15
申请号	US14/738636	申请日	2015-06-12
[标]申请(专利权)人(译)	chronisense医疗有限公司		
申请(专利权)人(译)	CHRONISENSE MEDICAL LTD.		
当前申请(专利权)人(译)	CHRONISENSE MEDICAL LTD.		
[标]发明人	LANGE DANIEL H		
发明人	LANGE, DANIEL H.		
IPC分类号	A61B5/0402 A61B5/00 A61B5/024 A61B5/103 A61B5/04		
CPC分类号	A61B5/0402 A61B5/1032 A61B5/681 A61B5/02416 A61B5/04012 A61B5/0022 A61B5/0205 A61B5/02427 A61B5/02438 A61B5/0245 A61B5/0428 A61B5/11 A61B5/4842 A61B5/6822 A61B5/6824 A61B5/6829 A61B5/721 A61B5/7239 A61B5/7275 A61B2562/046 A61B2562/06 G16H40/63 G16H80/00		
外部链接	<a href="#">Espacenet</a>	<a href="#">USPTO</a>	

摘要(译)

提供了一种用于使用可穿戴设备来测量心电图 ( ECG ) 的方法和系统。示例系统包括佩戴在患者的肢体 ( 例如, 手腕 ) 上的带的形状的可穿戴设备。可穿戴设备包括电传感器。可穿戴设备可操作以经由至少一个电传感器记录来自患者的肢体的电信号。可穿戴设备可操作以基于参考信号将电信号分割成段。参考信号包括心跳的开始时间的指示。对这些段求平均值以得到低信噪比的平均ECG数据。可佩戴装置包括可操作以测量肢体的脉动动脉下方的皮肤颜色的光学传感器。参考信号包括经由光学传感器与电信号同时记录的光电容描记图 ( PPG ) 信号。

