



(19) **United States**

(12) **Patent Application Publication**  
**Govari et al.**

(10) **Pub. No.: US 2019/0099133 A1**  
(43) **Pub. Date: Apr. 4, 2019**

- (54) **MIDDLE POINT ZERO REFERENCE**
- (71) Applicant: **Biosense Webster (Israel) Ltd.,**  
Yokneam (IL)
- (72) Inventors: **Assaf Govari,** Haifa (IL); **Vadim**  
**Gliner,** Haifa (IL)
- (73) Assignee: **Biosense Webster (Israel) Ltd.,**  
Yokneam (IL)
- (21) Appl. No.: **15/723,419**
- (22) Filed: **Oct. 3, 2017**

- (52) **U.S. Cl.**  
CPC ..... **A61B 5/6852** (2013.01); **A61B 5/04012**  
(2013.01); **A61N 1/365** (2013.01); **A61B**  
**5/0422** (2013.01); **A61B 5/0452** (2013.01);  
**A61B 5/044** (2013.01)

(57) **ABSTRACT**

A cardiac electrophysiology system including a means for identifying the source of an arrhythmia in the heart is disclosed. The disclosed system may be an electrocardiograph device and may generate an enhanced electrocardiogram (EKG) of a cardiac structure. The disclosed system may include a disclosed catheter inserted into a chamber of the cardiac structure. The disclosed catheter may include electrodes configured to measure an analog electrical signal of the electrical activity of the cardiac structure over time, and a transformer configured to remove a direct current (DC) offset of the analog electrical signal to generate an analog electrical signal centered at 0 volts (V), which may be sampled by an analog-to-digital converter (ADC) and gain adjusted to a maximum resolution of the ADC to produce an enhanced digital electrocardiogram (EKG) signal.

**Publication Classification**

- (51) **Int. Cl.**  
**A61B 5/00** (2006.01)  
**A61B 5/04** (2006.01)  
**A61B 5/044** (2006.01)  
**A61B 5/042** (2006.01)  
**A61B 5/0452** (2006.01)  
**A61N 1/365** (2006.01)

300

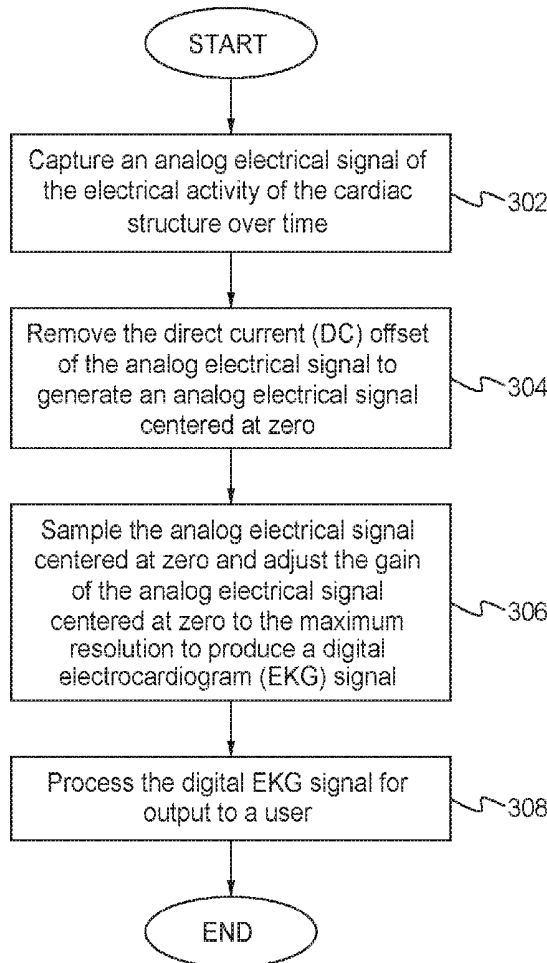



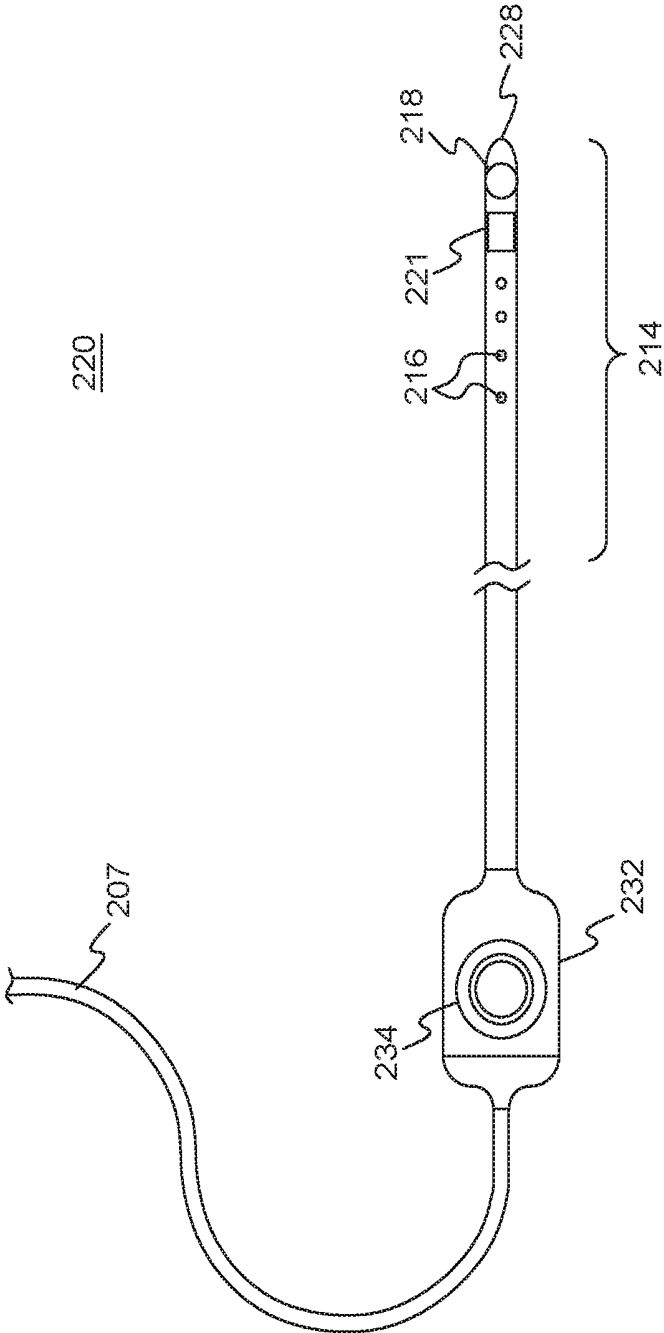

FIG. 2

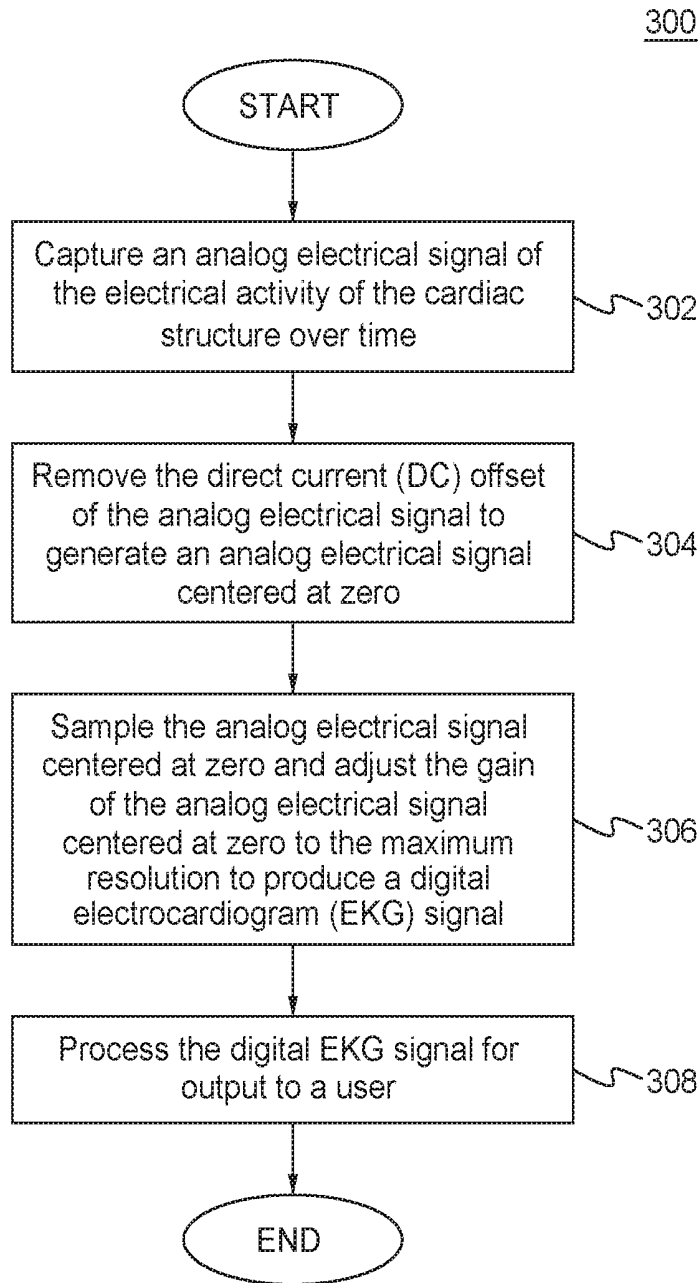

FIG. 3

## MIDDLE POINT ZERO REFERENCE

### SUMMARY

**[0001]** A cardiac electrophysiology system including a means for identifying the source of an arrhythmia in the heart is disclosed. The disclosed system may be an electrocardiograph device and may generate an enhanced electrocardiogram (EKG) of a cardiac structure. The disclosed system may include a disclosed catheter inserted into a chamber of the cardiac structure. The disclosed catheter may include electrodes configured to measure an analog electrical signal of the electrical activity of the cardiac structure over time, and a transformer configured to remove a direct current (DC) offset of the analog electrical signal to generate an analog electrical signal centered at 0 volts (V), which may be sampled by an analog-to-digital converter (ADC) and gain adjusted to a maximum resolution of the ADC to produce an enhanced digital electrocardiogram (EKG) signal.

### BRIEF DESCRIPTION OF THE DRAWINGS

**[0002]** FIG. 1 is a schematic diagram of an example electrocardiograph device **100**, in accordance with the disclosures herein;

**[0003]** FIG. 2 is a schematic diagram of an example catheter that may be included in the example electrocardiograph device of FIG. 1, in accordance with the disclosures herein; and

**[0004]** FIG. 3 is a flow diagram of an example procedure for generating an enhanced electrocardiogram (EKG) with single middle point zero reference inside the heart, in accordance with the disclosures herein.

### DETAILED DESCRIPTION OF THE EMBODIMENTS

**[0005]** Electrocardiography is a type of cardiology test that measures and records the electrical activity of the heart over a period of time using electrodes placed on the skin and/or inside the heart using a catheter. These electrodes detect the small electrical changes that arise from the heart muscle's electro-physiologic pattern of depolarizing during each heartbeat and thus can be used to detect abnormal cardiac conditions, such as myocardial infarction, pulmonary embolism, structural heart disease (e.g., cardiac murmur), or cardiac arrhythmia. Electrocardiography may be performed by an electrocardiograph machine and the resulting testing produces an electrocardiogram (abbreviated equivalently as EKG or ECG) showing the electrical signals in the heart, typically as graph of the voltage of the heart's electrical activity over time.

**[0006]** An example electrocardiograph system may include twelve leads and ten electrodes placed on the patient's limbs and on the surface of the chest. The overall magnitude of the electrical potential of the heart is measured from the twelve leads, each corresponding to a different measurement angle, and is recorded over a period of time. Electrocardiography performed with intracardiac electrodes, that are for example mounted on a catheter placed inside a chamber of the heart, produce an EKG referred to as an intracardiac electrocardiogram (ICEG), and may be utilized in combination with, or in the alternative to, the conventional twelve leads placed on the exterior of the patient. In order to measure heart muscle electrical activity, the EKG

electrodes have to be able to detect very small changes in potential energy on the patient's skin or heart tissue. For example, the electrical changes may be detected by EKG electrodes as cardiac electrical signals measuring on the order of 1 millivolt (mV) or less. An ICEG may be able to capture electrical morphologies that may not be detected on an EKG using surface electrodes on the body surface only, or at least with more accuracy in certain cases.

**[0007]** During each heartbeat, a healthy heart has an orderly progression of depolarization. This orderly pattern of depolarization gives rise to the characteristic EKG tracing. To the trained clinician, the morphology of the EKG signal conveys a large amount of information about the structure of the heart and the function of its electrical conduction system. Among other things, an EKG can be used to measure the rate and rhythm of heartbeats, the size and position of the heart chambers, the presence of any damage to the muscle cells or conduction system of the heart, the effects of cardiac drugs, and the function of implanted pacemakers. Interpretation of the EKG is fundamentally about understanding the electrical conduction system of the heart. Normal conduction starts and propagates in a predictable pattern, and deviation from this pattern can be a normal variation or be pathological.

**[0008]** While EKGs produced by existing electrocardiograph systems are widely used in diagnosing and monitoring cardiac conditions, they have some known limitations. For example, an arrhythmia is a rhythm defect in the heart in which the heart beats irregularly, too fast, or too slow. Initial detection of a cardiac arrhythmia may be possible by the simplest of means, such as auscultation of the heartbeat or feeling for peripheral pulses, however more advanced testing is needed to diagnose the specific arrhythmia, which typically involves miniscule electrical signals that can only be detected when a high degree of accuracy is used. A conventional ICEG, employing intracardiac electrodes, may provide specific diagnostic testing for assessment of arrhythmias, but in many cases may not be an accurate way to detect the specific source of the arrhythmia in the heart tissue, as explained below.

**[0009]** In a conventional intracardiac electrocardiograph system, an EKG electrode in contact with the skin and/or cardiac tissue measures heart signal current flowing into the electrode as a positive charge, and heart signal current flowing away from the electrode as a negative charge, to produce a voltage reading of the heart's electrical signals over time. A goal of an electrocardiograph system is to minimize the artifacts and maximize the accuracy of the EKG signal in order to provide reliable information to the physician.

**[0010]** Impedance (i.e., the opposition to the electrical current) due to the patient's internal geometry can be problematic for the accuracy of an EKG by distorting the accuracy of voltage readings provided at an EKG electrode. As a result, it may be difficult to localize the source of the arrhythmia in the heart in the presence of the impedance caused by the surrounding body. For example, various body types such as large bones, high muscle mass or high obesity, may have different distortion effects on how a particular electrical signal from the heart is read by the EKG electrodes.

**[0011]** The disclosed electrocardiograph system and method improves the accuracy of EKGs for purposes of identifying the source of the arrhythmia and other conditions

in the heart tissue by mitigating the distortion effects of the inherent impedance in the cardiac structure. Instead of using the heart's voltage as a reference voltage, a transformer (e.g., mounted on the catheter) that emits a low electric charge is placed inside the heart to create voltage signals recognized by the EKG electrodes to remove the voltage bias. For example, the electric charge emitted by the transformer may be on the order of several microvolts ( $\mu\text{V}$ ) (e.g., in the range of 1-100  $\mu\text{V}$ , or other example ranges). Thus, the transformer serves to find and isolate the control point, which is the area of maximum sensitivity where there is maximum change per unit of voltage due to the cardiac electrical activity.

[0012] Thus, according to the disclosed electrocardiograph system and method, the EKG electrodes are set together at the same middle point zero reference point and therefore measure cardiac electrical signals based on the charge emitted by the transformer inside the heart. Creating this single middle point zero reference inside the heart removes distortions due to impedance (e.g., caused by the geometry of the patient's internal body structure).

[0013] The catheter comprising the transformer and EKG electrodes may be moved around in the heart (e.g., by the physician physically moving the catheter via a handle) while emitting a small electric charge to stimulate the portion of the heart tissue causing the arrhythmia. For example, the electric charge emitted for stimulating cardiac tissue may be on the order of several millivolts (mV) (e.g., in the range of 1-100 mV, or other example ranges). The specific location of an arrhythmia may be located by the catheter because the muscle tissue causing the arrhythmia will respond, as atrial fibrillations, to the catheter so that the physician can isolate the arrhythmia on the EKG. Once the specific location of the arrhythmia in the heart is identified with the catheter, the EKG electrodes can take measurements of the isolated signals from the arrhythmia. The resulting EKG can be used as a more accurate tool to identify the source of an arrhythmia in the heart and to study the isolated heart tissue causing an arrhythmia.

[0014] FIG. 1 is a schematic diagram of an example electrocardiograph device 100, in accordance with the disclosures herein. The electrocardiograph device 100 may include, but is not limited to include, any of the following components: console system 101; intracardiac leads 107 connected to a catheter 120 with distal end 114 inserted into the heart 126 of the patient 105; non-contact electrodes 116 located at the distal end 114 of catheter 120; transformer 118 located at the distal end 114 of catheter 120; and leads 110 connected to electrodes 112 positioned in various locations on the skin of the patient 105. The console system 101 may include, but is not limited to include, any of the following components: analog-to-digital converter (ADC or A/D converter) 125; processor 130; data storage 155; data port printers 160; input/output (I/O) devices 165; visual display device 170; and/or energy source device 175. The processor 130 may include, but is not limited to include, any one or more of the following components: video controller 135; digital signal processor (DSP) 140; microprocessor 145; and/or microcontroller 150.

[0015] The catheter 120, leads 107 and 110, electrodes 112 and 116, transformer 118, and/or other components not shown (e.g., additional catheters, sensors, etc.) of the electrocardiograph device 100 may be used directly on, in, and/or in proximity to the patient 105 in order to gather information to be used for visualization, diagnostics, and

therapy (e.g., ablation therapy). This information may be provided to the console system 101 for processing, visualization and operator control and direction, some of which is described below.

[0016] The series of leads 110 and intracardiac leads 107 connect electrodes 112 on the surface of the skin of the patient 105 and electrodes 116 on the catheter 120 inside the heart 126, respectively, to the main console 101 of the electrocardiograph device 100. In an example, intracardiac catheter 120 may be used for diagnostic and/or therapeutic treatment, such as for mapping electrical potentials in the heart 126 of the patient 105. In an example, the catheter 120 may be inserted into the vascular system of the patient 105 so that the distal end 114 of the catheter 120 enters a chamber of the patient's heart 126. Although FIG. 1 shows a single catheter 120 and intracardiac lead 107, additional catheters and leads, not shown, with one or more electrodes, transformers and/or sensors may be similarly used. Moreover, an electrocardiograph device 100 may use only surface electrodes 112, or only intracardiac electrodes 116, or both the surface electrodes 112 and intracardiac electrodes 116 for the EKG readings.

[0017] A raw EKG signal 115 (i.e., analog input signal) is acquired from the electrodes 112 and/or 116 and converted from an analog to a digital format by the adjustable gain ADC 125. The ADC 125 generates and provides a digital output 117 of the EKG signal 115 by sampling the analog input signal 115 at a sampling rate. The resolution of the ADC 125 indicates the number of discrete values that the ADC 125 can produce over the range of analog values, and can be defined electrically in volts. The number of voltage intervals that the ADC 125 can produce is given by  $2^M$ , where M is the ADC's resolution in bits.

[0018] In an example, the ADC 125 may be implemented as an application specific integrated circuit (ASIC) with 24 bits of resolution, a dynamic range of 0 V to 5 V, and an adjustable gain. Then, the ADC 125 has a maximum voltage resolution defined over the 5 V range of  $5\text{V}/2^{24}=0.30\ \mu\text{V}$ . If an input signal is greater than 5 V, (e.g., 6 V), then it is out of range and cannot be sampled by the ADC 125. Similarly, if an analog input signal (e.g., a sine wave) has an amplitude of only 1 V, but is centered at 6 V DC offset, then the input signal is still out of range and cannot be sampled by the ADC 125. In another example, a meaningful analog EKG signal may have a maximum amplitude fluctuation on the order of 1 mV, but may have a 3 V DC bias. Then, the 24 bit resolution of the ADC 125 is used over the entire 3 V range and therefore cannot be used to provide a finer resolution of the smaller fluctuations.

[0019] However, if the transformer 118 is used, then the transformer 118 in the heart eliminates the DC offset of the cardiac electrical signal, so that the captured EKG signal is centered around 0V and the entire 24 bits resolution of the ADC 125 can be used to isolate the control point, which is the area of maximum sensitivity where there is maximum change per unit of voltage due to the cardiac electrical activity. Once the direct current (DC) offset is removed, the analog EKG signal may be amplified to the range of the ADC converter 125 (e.g., to 5 V) so that the entire scale of the resolution of the ADC converter 125 is used. For example, if the range of the ADC 124 is 5 V and the amplitude of the measured EKG signal is 1 mV, then a gain of 500 can be applied to the EKG signal to make use of the entire dynamic range.

**[0020]** Once the analog signal is converted, the ADC **125** communicates the digital EKG signal to the processor **130** to produce the EKG graph and/or perform other EKG analysis. Processor **130** may be coupled to data storage **155**, data ports and printers **160**, other I/O devices **165**, and a visual display device **170**, which may be used to display the EKG produced by electrocardiograph device **100**. The electrocardiograph device **100** and/or any of the components therein may be powered by one or more energy sources **175**.

**[0021]** Data storage **155** is any device that records information. Data storage may provide a storage medium for the signals included within device **100** and a place for calculations of processor **130** to be stored.

**[0022]** Microprocessor **145** may be a computer processor which incorporates the functions of a computer's central processing unit (CPU) on a single integrated circuit (IC), or a few integrated circuits. Microprocessor **145** may be a multipurpose, clock driven, register based, programmable electronic device which accepts digital or binary data as input, processes it according to instructions stored in its memory or data storage **155**, and provides results as output. Microprocessor **145** contains both combinational logic and sequential digital logic.

**[0023]** Micro controller **150** may be one or more small computers on a single integrated circuit. Micro controller **150** may contain one or more CPUs along with memory and programmable input/output peripherals. Program memory in the form of Ferroelectric RAM, NOR flash or OTP ROM is also often included on chip, as well as a small amount of RAM. Microcontrollers are designed for embedded applications, in contrast to the microprocessors used in personal computers or other general purpose applications consisting of various discrete chips.

**[0024]** DSP **140** may perform digital signal processing to perform a wide variety of signal processing operations. The signals processed in this manner are a sequence of numbers that represent samples of a continuous variable in a domain such as time, space, or frequency. Digital signal processing can involve linear or nonlinear operations. Nonlinear signal processing is closely related to nonlinear system identification and can be implemented in the time, frequency, and spatio-temporal domains. The application of digital computation to signal processing allows for many advantages over analog processing in many applications, such as error detection and correction in transmission as well as data compression. DSP is applicable to both streaming data and static (stored) data.

**[0025]** FIG. 2 is a schematic diagram of an example catheter **220** that may be included in the example electrocardiograph device **100** of FIG. 1 (e.g., catheter **120** in FIG. 1), in accordance with the disclosures herein. The catheter **220** may be connected to an electrocardiograph console via lead **207**. The catheter **220** may include, but is not limited to include, any one or more of the following components: distal end **214**; electrodes **216**; transformer **218**; positioning sensors **221**; distal tip **228**; handle **232**; and/or controls **234**.

**[0026]** The distal end **214** of the catheter **220** may include electrodes **216** at the distal tip **228** that may be used to measure electrical properties of the cardiac tissue. The electrodes **216** may also be used to send electrical signals to the heart for diagnostic purposes. The electrodes **216** may also perform ablation on defective cardiac tissue by applying energy (e.g., RF energy) directly to the cardiac tissue at the desired location of ablation. In an example, the electrodes

**216** may include non-contact electrodes arranged in an array, which may be used to simultaneously receive and measure far-field electrical signals from the walls of the heart chamber of the patient. The electrodes **216** provide information regarding the electrical properties of the heart to an electrocardiograph console for processing.

**[0027]** The distal end **214** includes transformer **218** that may eliminate the DC offset in a captured analog EKG signal, so that the captured EKG signal is centered on 0 V to isolate the control point, which is the area of maximum sensitivity where there is maximum change per unit of voltage due to the cardiac electrical activity.

**[0028]** The distal end **214** may include positioning sensors **221** (also called location sensors) in the distal tip **228** of the catheter **220** that may generate signals used to determine the position and orientation (and/or distance) of the catheter **220** in the body. In an example, the relative position and orientation of the positioning sensors **221**, the electrodes **216**, and the distal tip **228** are fixed and known in order to facilitate accurate positioning information of the distal tip **228**. For example, the position of the positioning sensors **221** may be determined in part based on the relative position to known positions outside the heart (e.g., based on extra-cardiac sensors, not shown). The use of positioning sensors **221** may provide improved location accuracy within the magnetic fields in the surrounding space and provide location information that is adaptable to patient movement because the position information of the catheter **220** is relative to the anatomy of the patient.

**[0029]** The handle **232** of the catheter **220** may be operated by the physician and may include controls **234** to enable the physician to effectively steer the distal tip **228** in the desired direction.

**[0030]** FIG. 3 is a flow diagram of an example procedure **300** for generating an enhanced EKG with single middle point zero reference inside the heart, in accordance with the disclosures herein. The example procedure **300** may be implemented in an electrocardiograph system, such as the example electrocardiograph device **100** of FIG. 1.

**[0031]** At **302**, an analog electrical signal of the electrical activity of the cardiac structure over time may be captured, for example using electrodes located on an intracardiac catheter and/or on the surface of the skin. At **304**, the DC offset of the analog electrical signal may be removed, for example using an intracardiac transformer, to generate an analog electrical signal centered at zero. At **306**, the analog electrical signal centered at zero may be sampled and a gain of the analog electrical signal centered at zero may be adjusted to the maximum range to produce a digital EKG signal. At **308**, the digital EKG signal may be processed for output to the user, for example as an EKG reading printed or displayed on a visual display device.

**[0032]** Many variations are possible based on the disclosure herein. Although features and elements are described above in particular combinations, each feature or element can be used alone without the other features and elements or in various combinations with or without other features and elements.

**[0033]** The systems and procedures described herein may be implemented in hardware, and/or software. A computer-based system for performing electrocardiography may be capable of running software modules that introduce additional features including the procedures described herein. The procedures described herein may enable advanced car-

diac visualization, and diagnostic capabilities to enhance clinicians' ability to diagnose and treat heart rhythm disorders. Although the procedures disclosed herein describe with respect to electrocardiography procedures within the heart, the devices and procedures may be similarly used for electrophysiology procedures in other parts of the body, such as, but not limited to, electroencephalography in the brain, electrooculography in the eye, and electropneumography in the lungs.

**[0034]** The methods provided may include implementation in a general purpose computer, a processor, or a processor core. Suitable processors include, by way of example, a general purpose processor, a special purpose processor, a conventional processor, a digital signal processor (DSP), a plurality of microprocessors, one or more microprocessors in association with a DSP core, a controller, a microcontroller, Application Specific Integrated Circuits (ASICs), Field Programmable Gate Arrays (FPGAs) circuits, any other type of integrated circuit (IC), and/or a state machine. Such processors can be manufactured by configuring a manufacturing process using the results of processed hardware description language (HDL) instructions and other intermediary data including netlists (such instructions capable of being stored on a computer readable media). The results of such processing can be mask works that are then used in a semiconductor manufacturing process to manufacture a processor which implements the methods described herein.

**[0035]** The methods or flow charts provided herein may be implemented in a computer program, software, or firmware incorporated in a non-transitory computer-readable storage medium for execution by a general purpose computer or a processor. Examples of non-transitory computer-readable storage mediums include a ROM, a random access memory (RAM), a register, cache memory, semiconductor memory devices, magnetic media such as internal hard disks and removable disks, magneto-optical media, and optical media such as CD-ROM disks, and digital versatile disks (DVDs).

What is claimed is:

1. A system configured to generate an enhanced electrocardiogram (EKG) of a cardiac structure, the system comprising:

a catheter configured for insertion into a chamber of the cardiac structure, the catheter comprising:

a plurality of electrodes configured to measure an analog electrical signal of electrical activity of the cardiac structure over time;

a transformer configured to remove a direct current (DC) offset of the analog electrical signal to generate an analog electrical signal centered at 0 volts (V);

the catheter configured to provide the analog electrical signal centered at 0 V to a console system, the console system comprising:

an analog-to-digital converter (ADC) configured to sample the analog electrical signal centered at 0 V and adjust a gain of the analog electrical signal centered at 0 V to a maximum resolution of the ADC to produce a digital electrocardiogram (EKG) signal; and

a processor configured to process the digital EKG signal for output to a user.

2. The system of claim 1 configured as an electrocardiograph device.

3. The system of claim 1, wherein the transformer is configured to remove the DC offset by emitting a low electric charge.

4. The system of claim 1, wherein the maximum resolution of the ADC is based on a dynamic voltage range of the ADC.

5. The system of claim 1, wherein the console system further comprises:

a visual display device configured to visually display the digital EKG signal.

6. The system of claim 1 further comprising:

body surface electrodes configured to capture a second analog electrical signal of the electrical activity of the cardiac structure over time and provide the second analog electrical signal to the console system.

7. The system of claim 1, wherein the catheter is further configured to emit a small electric charge to stimulate tissue in the cardiac structure to detect a location of an arrhythmia.

8. The system of claim 1, wherein a position of the catheter is controlled manually by the user.

9. The system of claim 1, wherein the catheter further comprises:

positioning sensors configured to generate position and orientation information of the catheter and provide the position and orientation information to the console system.

10. The system of claim 9, wherein the processor is further configured to process and provide the position and orientation information of the catheter to the user.

11. A method for generating an enhanced electrocardiogram (EKG) of a cardiac structure, the method comprising: inserting a catheter into a chamber of the cardiac structure;

measuring, by a plurality of electrodes mounted on the catheter, an analog electrical signal of electrical activity of the cardiac structure over time;

removing, using a transformer mounted on the catheter, a direct current (DC) offset of the analog electrical signal to generate an analog electrical signal centered at 0 volts (V);

sampling the analog electrical signal centered at 0 V and adjusting a gain of the analog electrical signal centered at 0 V to a maximum resolution to produce a digital electrocardiogram (EKG) signal; and

processing the digital EKG signal for output to a user.

12. The method of claim 11 performed by an electrocardiograph device.

13. The method of claim 11, wherein the removing the DC offset includes emitting, by the transformer, a low electric charge.

14. The method of claim 11, wherein the maximum resolution is based on a dynamic voltage range of an analog-to-digital converter (ADC).

15. The method of claim 11, further comprising:

visually displaying the digital EKG signal on a visual display device.

16. The method of claim 11 further comprising:

measuring, by body surface electrodes, a second analog electrical signal of the electrical activity of the cardiac structure over time.

17. The method of claim 11, further comprising:

emitting, by the catheter, a small electric charge to stimulate tissue in the cardiac structure to detect a location of an arrhythmia.

**18.** The method of claim **11**, further comprising:  
manually controlling, by the user, a position of the catheter.

**19.** The method of claim **11**, further comprising:  
generating position and orientation information of the catheter.

**20.** The method of claim **19**, further comprising:  
processing and providing the position and orientation information of the catheter to the user.

\* \* \* \* \*

专利名称(译)	中点零参考		
公开(公告)号	<a href="#">US20190099133A1</a>	公开(公告)日	2019-04-04
申请号	US15/723419	申请日	2017-10-03
[标]申请(专利权)人(译)	韦伯斯特生物官能(以色列)有限公司		
申请(专利权)人(译)	生物传感韦伯斯特 ( 以色列 ) LTD.		
当前申请(专利权)人(译)	生物传感韦伯斯特 ( 以色列 ) LTD.		
[标]发明人	GOVARI ASSAF GLINER VADIM		
发明人	GOVARI, ASSAF GLINER, VADIM		
IPC分类号	A61B5/00 A61B5/04 A61B5/044 A61B5/042 A61B5/0452 A61N1/365		
CPC分类号	A61B5/6852 A61B5/04012 A61B5/044 A61B5/0422 A61B5/0452 A61N1/365		
其他公开文献	US10321876		
外部链接	<a href="#">Espacenet</a> <a href="#">USPTO</a>		

摘要(译)

公开了一种心脏电生理系统，包括用于识别心脏中心律失常源的装置。所公开的系统可以是心电图仪设备并且可以生成心脏结构的增强的心电图 ( EKG )。所公开的系统可包括插入心脏结构的腔室中的公开的导管。所公开的导管可包括配置成随时间测量心脏结构的电活动的模拟电信号的电极，以及配置成去除模拟电信号的直流 ( DC ) 偏移以产生以中心为中心的模拟电信号的变压器。0伏特 ( V )，可以通过模数转换器 ( ADC ) 进行采样，并将增益调整到ADC的最大分辨率，以产生增强的数字心电图 ( EKG ) 信号。

