



(19) **United States**

(12) **Patent Application Publication**
Volpe et al.

(10) **Pub. No.: US 2016/0317059 A1**
(43) **Pub. Date: Nov. 3, 2016**

(54) **SELECTION OF OPTIMAL CHANNEL FOR RATE DETERMINATION**

A61B 5/0432 (2006.01)

A61B 5/0472 (2006.01)

A61N 1/39 (2006.01)

(71) Applicant: **ZOLL MEDICAL CORPORATION**,
Chelmsford, MA (US)

A61B 5/0452 (2006.01)

A61B 5/00 (2006.01)

(72) Inventors: **Shane S. Volpe**, Saltsburg, PA (US);
Thomas E. Kaib, North Huntingdon,
PA (US)

(52) **U.S. Cl.**

CPC *A61B 5/04288* (2013.01); *A61B 5/04525*

(2013.01); *A61B 5/0245* (2013.01); *A61B*

5/04012 (2013.01); *A61B 5/6804* (2013.01);

A61B 5/7221 (2013.01); *A61B 5/0432*

(2013.01); *A61B 5/0472* (2013.01); *A61B*

5/7475 (2013.01); *A61N 1/3925* (2013.01);

A61N 1/046 (2013.01); *A61N 1/0484*

(2013.01); *A61B 2560/0214* (2013.01)

(73) Assignee: **ZOLL MEDICAL CORPORATION**,
Chelmsford, MA (US)

(21) Appl. No.: **15/205,584**

(22) Filed: **Jul. 8, 2016**

(57)

ABSTRACT

Related U.S. Application Data

(63) Continuation of application No. 14/536,189, filed on
Nov. 7, 2014, now Pat. No. 9,408,548, which is a
continuation of application No. 13/428,329, filed on
Mar. 23, 2012, now Pat. No. 8,897,860.

According to at least one example, an ambulatory medical device is provided. The device includes a plurality of electrodes disposed at spaced apart positions about a patient's body and a control unit. The control unit includes a sensor interface, a memory and a processor. The sensor interface is coupled to the plurality of electrodes and configured to receive a first ECG signal from a first pairing of the plurality of electrodes and to receive a second ECG signal from a second pairing of the plurality of electrodes. The memory stores information indicating a preferred pairing, the preferred pairing being either the first pairing or the second pairing. The processor is coupled to the sensor interface and the memory and is configured to resolve conflicts between interpretations of first ECG signal and the second ECG signal in favor of the preferred pairing.

(60) Provisional application No. 61/467,599, filed on Mar. 25, 2011.

Publication Classification

(51) **Int. Cl.**

A61B 5/0428 (2006.01)

A61B 5/0245 (2006.01)

A61B 5/04 (2006.01)

A61N 1/04 (2006.01)

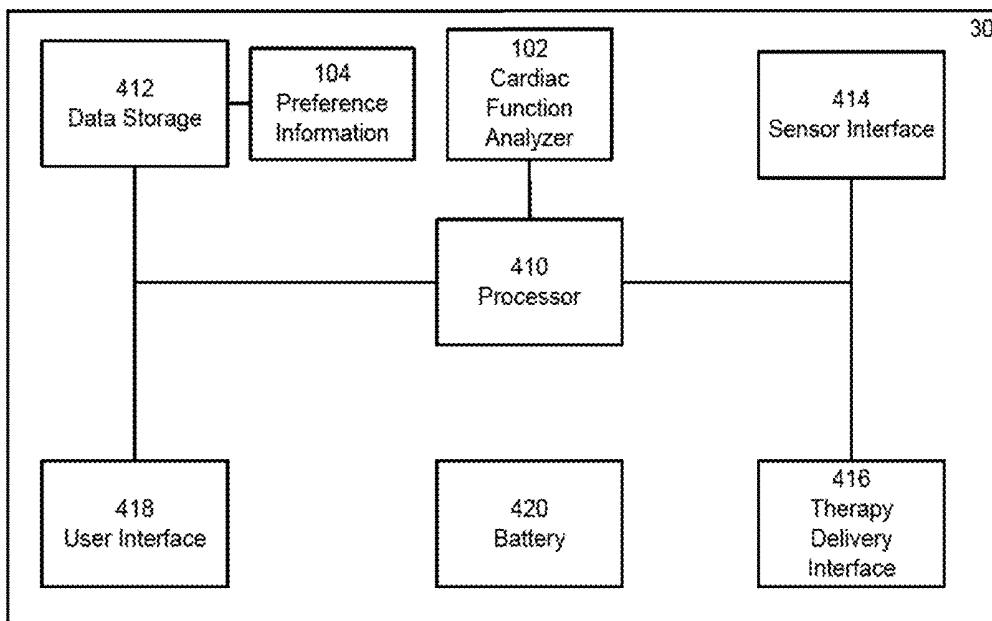

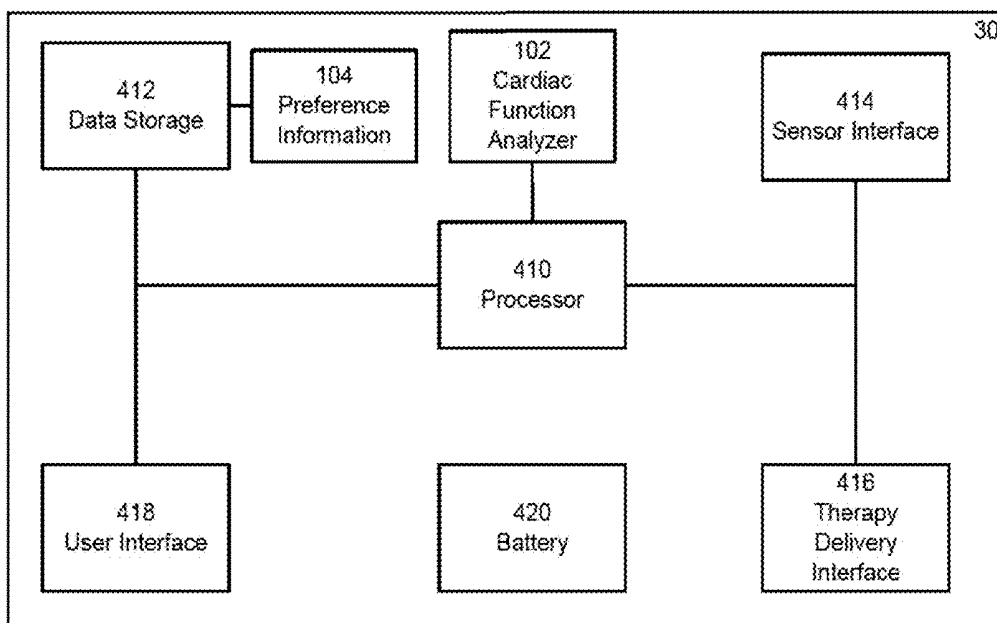

FIG. 1

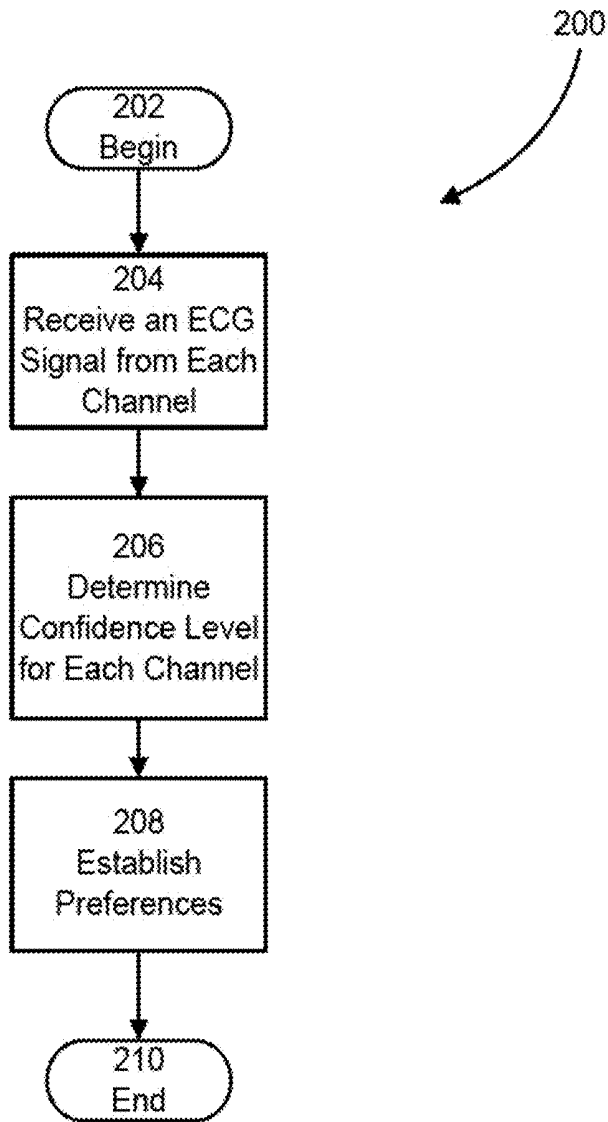

FIG. 2

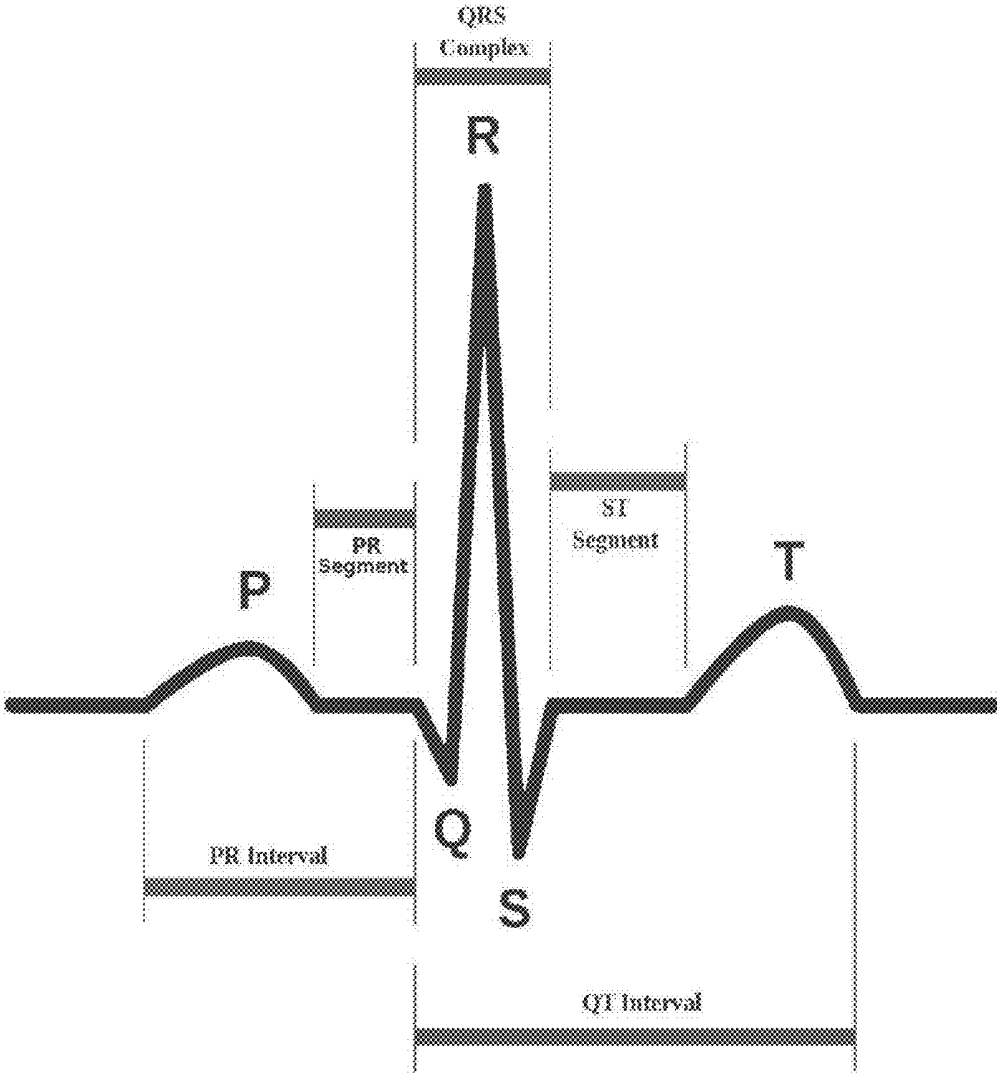

FIG. 3
(PRIOR ART)

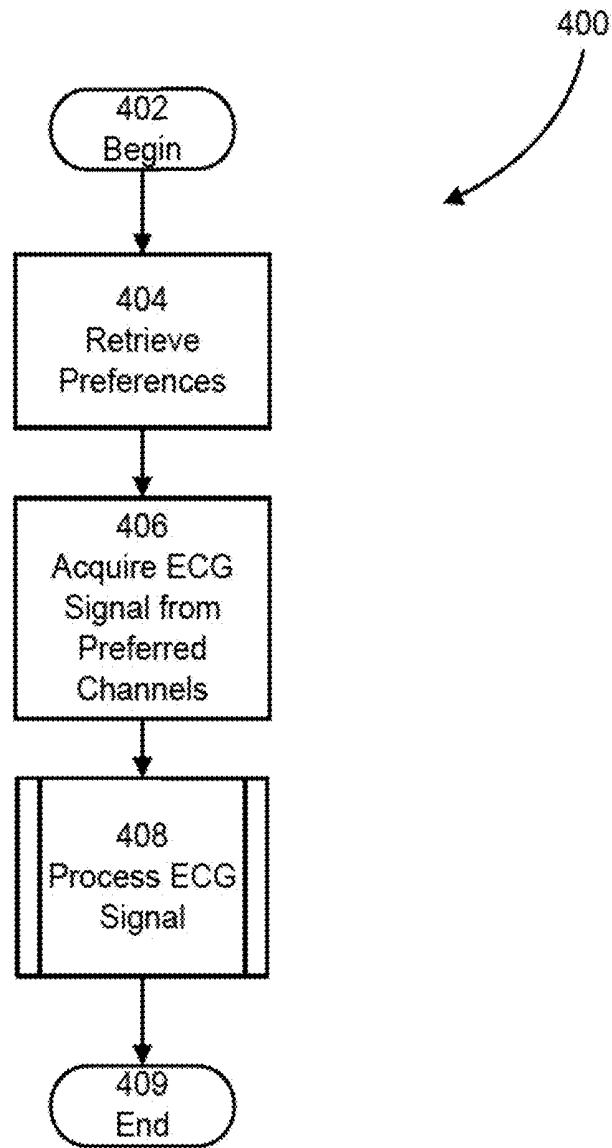

FIG. 4

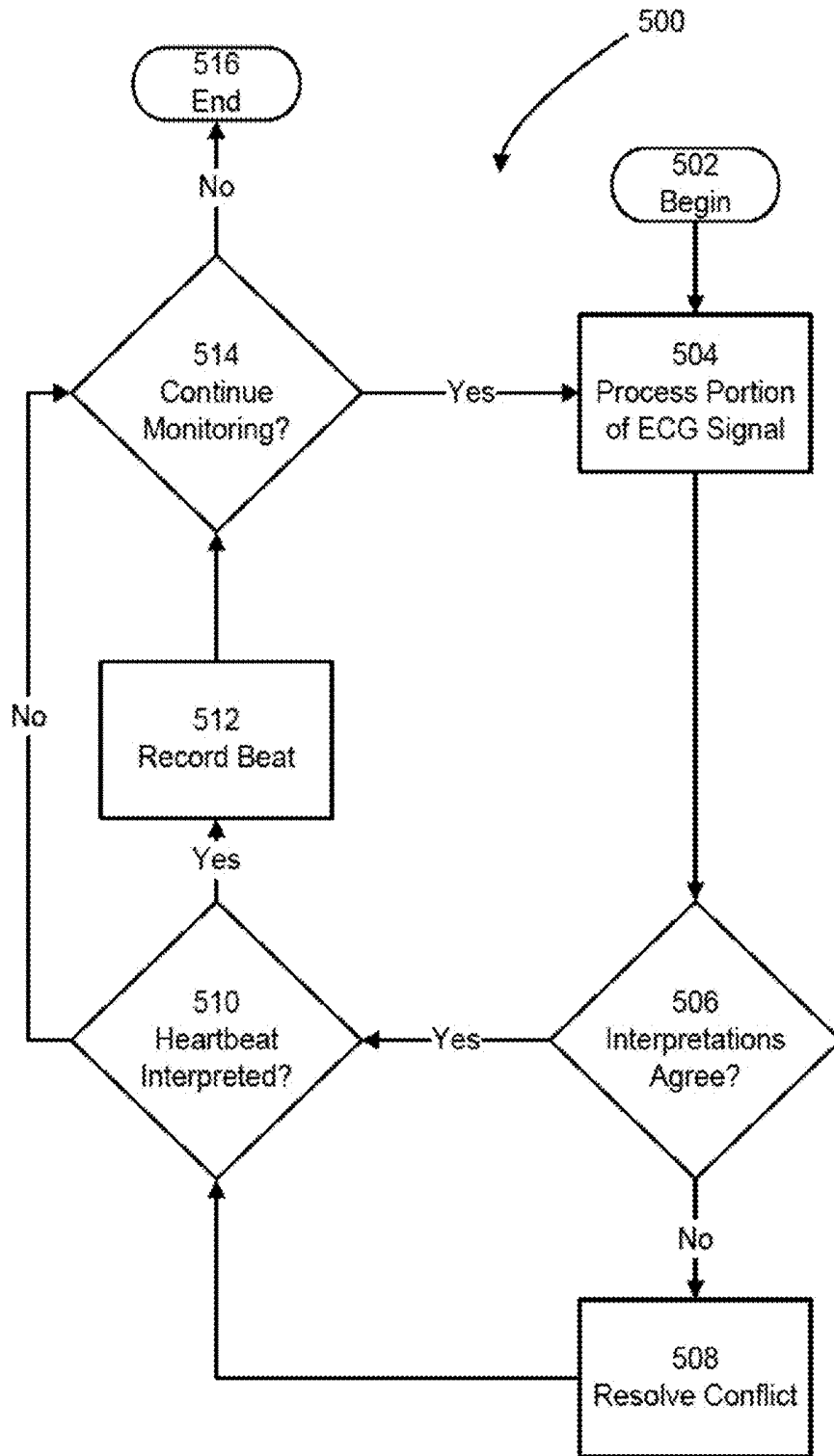

FIG. 5

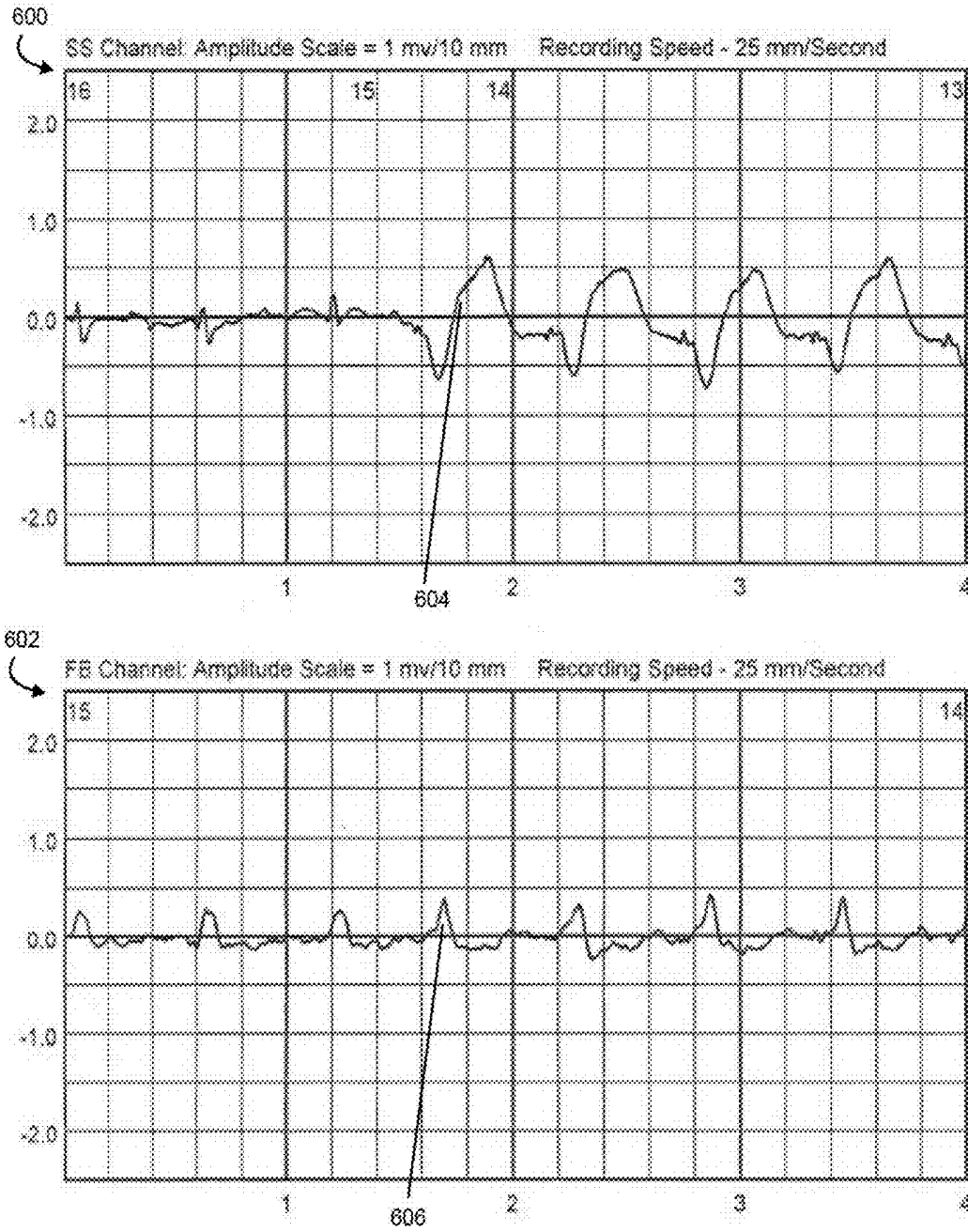

FIG. 6

SELECTION OF OPTIMAL CHANNEL FOR RATE DETERMINATION

RELATED APPLICATIONS

[0001] This application claims the benefit under 35 U.S.C. §120 as a continuation of U.S. application Ser. No. 14/536,189, titled "SELECTION OF OPTIMAL CHANNEL FOR RATE DETERMINATION," filed on Nov. 7, 2014, which claims the benefit under 35 U.S.C. §120 as a continuation of U.S. application Ser. No. 13/428,329, titled "SELECTION OF OPTIMAL CHANNEL FOR RATE DETERMINATION," filed on Mar. 23, 2012, which claims priority under 35 U.S.C. §119(e) to U.S. Provisional Application Ser. No. 61/467,599, titled "SELECTION OF OPTIMAL CHANNEL FOR RATE DETERMINATION," filed on Mar. 25, 2011, all of which are hereby incorporated herein by reference in their entireties for all purposes.

BACKGROUND

[0002] 1. Technical Field

[0003] Examples disclosed herein relate generally to the detection of cardiac function in a patient, and more particularly to the detection of cardiac function and the treatment of cardiac conditions in an ambulatory medical device, such as a wearable defibrillator.

[0004] 2. Discussion

[0005] With a wearable defibrillator worn by an ambulatory patient, the patient's electrocardiogram (ECG) signal is obtained from body surface electrodes. Determining the true characteristics of an ambulatory patient's cardiac cycle based on an ECG signal in this manner can be difficult. Electrical noise and electrode fall-off frequently degrade the quality of the ECG signal. In addition, the characteristics of ECG signals vary from patient to patient due to factors such as the patient's state of health, individual physiology, and electrode positions on the body surface.

[0006] Known ambulatory wearable defibrillators, such as the LifeVest® Wearable Cardioverter Defibrillator available from Zoll Medical Corporation of Chelmsford, Mass., use four ECG sensing electrodes in a dual-channel configuration. That is, an electrical signal provided by one of the four ECG sensing electrodes is paired with the electrical signal provided by another of the four ECG sensing electrodes to form a channel. This arrangement of ECG sensing electrodes is usually suitable because in most cases it is rare that noise or electrode movement affects the entire body circumference. The dual-channel configuration provides redundancy and allows the system to operate on a single channel if necessary. Because signal quality also varies from patient to patient, having two channels provides the opportunity to have improved signal pickup, since the ECG sensing electrodes are located in different body positions.

SUMMARY

[0007] Examples disclosed herein are directed to a wearable medical device that monitors ECG signals received on a plurality of channels and interprets the ECG signals according to a set of preferences. This set of preferences indicates which channels and detection methods are more likely to provide accurate results for the patient wearing the wearable medical device. By interpreting ECG signals

according to the set of preferences, the wearable medical device decreases the frequency of falsely detected cardiac malfunctions.

[0008] According to one example, an ambulatory medical device is provided. The device includes a plurality of electrodes disposed at spaced apart positions about a patient's body and a control unit. The control unit includes a sensor interface coupled to the plurality of electrodes and configured to receive a first ECG signal from a first pairing of the plurality of electrodes and to receive a second ECG signal from a second pairing of the plurality of electrodes, a memory storing information indicating a preferred pairing, the preferred pairing being either the first pairing or the second pairing and a processor coupled to the sensor interface and the memory and configured to resolve conflicts between interpretations of first ECG signal and the second ECG signal in favor of the preferred pairing. In some examples, the first pairing includes electrodes that are distinct from the electrodes included in the second pairing. In other examples, one of the plurality of electrodes is common between the first and second pairings. The device may include a plurality of electrodes that are integrated into a garment that is worn about a patient's body. In addition, the interpretations of the ECG signals may detect heartbeats.

[0009] According to another example, a method of monitoring ECG signals is provided. In some examples, the method is executed by an ambulatory medical device as described herein. The method includes acts of determining a first interpretation of a first ECG signal provided by a first channel of the plurality of channels, determining a second interpretation of a second ECG signal provided by a second channel of the plurality of channels, determining which one of the first channel and the second channel provides a more reliable ECG signal and resolving a conflict between the first interpretation and the second interpretation based upon which of the first channel and the second channel is determined to provide the more reliable ECG signal.

[0010] According to at least one example, an ambulatory medical device is provided. The device includes a plurality of electrodes disposed at spaced apart positions about a patient's body and a control unit. The control unit includes a sensor interface, a memory and a processor. The sensor interface is coupled to the plurality of electrodes and configured to receive a first ECG signal from a first pairing of the plurality of electrodes and to receive a second ECG signal from a second pairing of the plurality of electrodes. The memory stores information indicating a preferred pairing, the preferred pairing being either the first pairing or the second pairing. The processor is coupled to the sensor interface and the memory and is configured to resolve conflicts between interpretations of first ECG signal and the second ECG signal in favor of the preferred pairing.

[0011] The device may further comprise a garment that is configured to be worn about the patient's body. The plurality of electrodes may be integrated into the garment. The plurality of electrodes may include adhesive electrodes. In some examples, the interpretations of the ECG signals may detect heartbeats.

[0012] In the device, the information indicating the preferred pairing may include information indicating a first heart rate detection method preferred for the first pairing and a second heart rate detection method preferred for the second pairing. The processor may be further configured to interpret the first ECG signal using the first heart rate

detection method and interpret the second ECG signal using the second heart rate detection method.

[0013] In the device, the processor may be further configured to determine a first confidence level for the first pairing, determine a second confidence level for the second pairing, determine the preferred pairing with reference to the first confidence level and the second confidence level and store the information indicating the preferred pairing in the memory. In addition, the processor may be configured to determine the first confidence level by comparing the first ECG signal to benchmark information. The benchmark information may reflect a particular patient's normal rhythm. In addition, the processor may be configured to compare the first ECG signal to the benchmark information by comparing a morphology of the first ECG signal to a morphology indicated within the benchmark information.

[0014] According to another example, a method of monitoring ECG signals using an ambulatory medical device is provided. The method includes acts of receiving, by the ambulatory medical device, a first ECG signal from a first pairing of a plurality of electrodes, receiving a second ECG signal from a second pairing of the plurality of electrodes and resolving conflicts between interpretations of first ECG signal and the second ECG signal in favor of a preferred pairing being either the first pairing or the second pairing.

[0015] In the method, the act of resolving the conflicts between the interpretations may include resolving conflicts between interpretations that detect heartbeats. The method may further comprise acts of interpreting the first ECG signal using a first heart rate detection method and interpreting the second ECG signal using a second heart rate detection method. The first heart rate detection method may be different from the second heart rate detection method.

[0016] The method may further comprise acts of determining a first confidence level for the first pairing, determining a second confidence level for the second pairing and determining the preferred pairing with reference to the first confidence level and the second confidence level. In the method, the act of determining the first confidence level may include an act of comparing the first ECG signal to benchmark information. The act of comparing the first ECG signal to the benchmark information may include comparing the first ECG signal to benchmark information that reflects a particular patient's normal rhythm. In addition, the act of comparing the first ECG signal to the benchmark information may include comparing a morphology of the first ECG signal to a morphology indicated within the benchmark information.

[0017] In another example, a non-transitory computer readable medium having stored thereon sequences of instruction for monitoring ECG signals is provided. The instructions instruct at least one processor to receive a first ECG signal from a first pairing of the plurality of electrodes, receive a second ECG signal from a second pairing of the plurality of electrodes and resolve conflicts between interpretations of first ECG signal and the second ECG signal in favor of a preferred pairing being either the first pairing or the second pairing.

[0018] Furthermore, the instructions may further instruct the at least one processor to determine a first confidence level for the first pairing, determine a second confidence level for the second pairing and determine the preferred pairing with reference to the first confidence level and the second confidence level. The instructions that instruct the at

least one processor to determine the first confidence level may include instructions that instruct the at least one processor to compare the first ECG signal to benchmark information. The instructions that instruct the at least one processor to compare the first ECG signal to the benchmark information may include instructions that instruct the at least one processor to compare a morphology of the first ECG signal to a morphology indicated within the benchmark information.

[0019] Still other aspects, examples, and advantages of these exemplary aspects and examples, are discussed in detail below. Moreover, it is to be understood that both the foregoing information and the following detailed description are merely illustrative examples of various aspects, and are intended to provide an overview or framework for understanding the nature and character of the claimed subject matter. References to "an example," "some examples," "an alternate example," "various examples," "one example," "at least one example," "this and other examples" or the like are not necessarily mutually exclusive and are intended to indicate that a particular feature, structure, or characteristic described in connection with the example may be included in that example and other examples. The appearances of such terms herein are not necessarily all referring to the same example.

[0020] Furthermore, in the event of inconsistent usages of terms between this document and documents incorporated herein by reference, the term usage in the incorporated references is supplementary to that of this document; for irreconcilable inconsistencies, the term usage in this document controls. In addition, the accompanying drawings are included to provide illustration and a further understanding of the various aspects and examples, and are incorporated in and constitute a part of this specification. The drawings, together with the remainder of the specification, serve to explain principles and operations of the described and claimed aspects and examples.

BRIEF DESCRIPTION OF DRAWINGS

[0021] The accompanying drawings are not intended to be drawn to scale. In the drawings, components that are identical or nearly identical may be represented by a like numeral. For purposes of clarity, not every component is labeled in every drawing. In the drawings:

[0022] FIG. 1 is a functional schematic diagram of an exemplary control unit used to control electrode systems;

[0023] FIG. 2 is a flow chart of an exemplary process for configuring ECG signal processing preferences;

[0024] FIG. 3 is a schematic diagram of an ECG signal produced by a normal cardiac cycle;

[0025] FIG. 4 is a flow chart of an exemplary process for detecting cardiac function from a portion of an ECG signal;

[0026] FIG. 5 is a flow chart of an exemplary process for interpreting ECG signals according to a set of ECG signal processing preferences; and

[0027] FIG. 6 is an exemplary ECG signal produced by an idiosyncratic cardiac cycle.

DETAILED DESCRIPTION

[0028] Examples disclosed herein manifest an appreciation that some patients regularly produce ECG signals that are highly idiosyncratic. In these instances, the electrical signals generated during these patient's cardiac cycles can

cause conventional heart rate detection methods to detect an erroneous number of heartbeats over a given period of time. These errors are particularly problematic to a wearable medical device, such as a wearable defibrillator, because, within this context, a real-time determination of heart rate can be matter of life and death importance. For this reason, wearable medical devices that monitor heart rate tend to interpret ECG signals in a conservative light and err on the side of reporting potential arrhythmias or other cardiac malfunction to a patient, physician or others. An unfortunate side-effect of this approach is that, in some instances, patients are forced to regularly deal with falsely indicated cardiac malfunction.

[0029] The conventional heart rate detection methods mentioned above include derivative-based QRS detectors that detect heartbeats by identifying QRS complexes, which are representative of ventricular depolarization, within an ECG signal. Conventional derivative-based QRS detectors identify QRS complexes by comparing a slope of the ECG signal to established thresholds. For example, a conventional derivative-based QRS detector may compare a magnitude of the slope of the R wave portion of the QRS complex to a threshold, and if the magnitude exceeds the threshold, the QRS detector may indicate the occurrence of a heartbeat. Typically, such derivative-based QRS detectors are configured (via hardware or software) to the morphology of the heart, and the patient.

[0030] For instance, to prevent over counting, the QRS detector may be configured to detect an occurrence of a QRS complex only after a minimum amount of time has transpired after a prior QRS complex. In some examples this minimum amount of time, which is referred to herein as the “refractory period” or the “programmed refractory period,” is typically configured to be about 200 milliseconds. Moreover, the QRS detector may also be configured to use an adaptive threshold that is based upon prior samples of the patient’s ECG signal, to account for variations from one patient to another, or to changes in the patient’s medical condition. Upon identifying a QRS complex in this manner, conventional derivative-based QRS detectors indicate the occurrence of a heartbeat.

[0031] Given their reliance on slope, conventional derivative-based QRS detectors may double count heartbeats where a patient’s normal rhythm presents an elongated QRS complex or an abnormally sharp T wave. For example, if the QRS complex generated by the patient’s normal rhythm has a duration that exceeds the configured refractory period of the QRS detector, the QRS detector may detect a heartbeat at the beginning of the QRS complex and, after the refractory period has expired, detect another heartbeat near the end of the QRS complex. In another example, if the amplitude of the ECG signal is small, the adaptive thresholds used by the QRS detector may adjust to low values. In this situation, even a moderate spike in one of the other waves, such as the T wave, that occurs after expiration of the refractory period may result in a slope steep enough to cause the QRS detector to indicate the occurrence of a false heartbeat.

[0032] To address these difficulties, some exemplary wearable medical devices disclosed herein process ECG signals from multiple channels according to a set of preference information that is tailored to fit the characteristics of the patient wearing the wearable medical device. The set of preference information may include, among other information, information indicating preferred channels and rate

detection methods for the patient. For instance, in at least one example, a wearable medical device processes ECG signals received via two channels, namely a front to back channel and a side to side channel, using one or more QRS rate detectors, which may include, for example, one or more conventional QRS rate detectors. According to this example, the wearable medical device resolves conflicts between these two channels in favor of a previously identified, preferred channel. Further, in some examples, the set of preference information is automatically configured by the wearable medical device and continuously adjusted during its operation. For example, the set of preference information may be adjusted based on the current health of the patient, the activity of the patient, and the present locations of the electrodes relative to the patient’s body.

[0033] The examples of the processes and apparatuses described herein are not limited in application to the details of construction and the arrangement of components set forth in the following description or illustrated in the accompanying drawings. The methods and apparatuses are capable of implementation in other examples and of being practiced or of being carried out in various ways. Examples of specific implementations are provided herein for illustrative purposes only and are not intended to be limiting. In particular, acts, elements and features discussed in connection with any one or more examples are not intended to be excluded from a similar role in any other examples.

[0034] Also, the phraseology and terminology used herein is for the purpose of description and should not be regarded as limiting. Any references to examples or elements or acts of the systems and methods herein referred to in the singular may also embrace examples including a plurality of these elements, and any references in plural to any example or element or act herein may also embrace examples including only a single element. References in the singular or plural form are not intended to limit the presently disclosed systems or methods, their components, acts, or elements. The use herein of “including,” “comprising,” “having,” “containing,” “involving,” and variations thereof is meant to encompass the items listed thereafter and equivalents thereof as well as additional items. References to “or” may be construed as inclusive so that any terms described using “or” may indicate any of a single, more than one, and all of the described terms.

Electrode System

[0035] U.S. Pat. No. 8,706,215, titled “WEARABLE AMBULATORY MEDICAL DEVICE WITH MULTIPLE SENSING ELECTRODES,” issued Apr. 22, 2014 (hereinafter the “’215 patent”), which is incorporated by reference herein in its entirety, describes an apparatus and method for processing ECG signals using one or more channels. With reference to FIGS. 1A and 1B, the ’215 patent discloses an electrode system **100** that incorporates a control unit **30**. As described with reference to FIG. 4 in the ’215 patent, at least one example of the control unit **30** includes a processor **410**, data storage **412**, a sensor interface **414**, a therapy delivery interface **416**, a user interface **418** and a battery **420**.

[0036] Some of the examples disclosed herein for processing ECG signals according to a set of preferences are implemented using the electrode system **100** disclosed in the ’215 patent. FIG. 1 illustrates the control unit **30** of one such example. As shown in FIG. 1, the control unit **30** includes

two additional components: a cardiac function analyzer **102** and preference information **104**.

[0037] The cardiac function analyzer **102** is configured to analyze a portion of the ECG signal to configure preference information, such as the preference information **104**, and to determine cardiac functions of the patient using the preference information. The cardiac function analyzer **102** may be implemented using hardware or a combination of hardware and software. For instance, in one example, the cardiac function analyzer **102** is implemented as a software component that is stored within the data storage **412** and executed by the processor **410**. In this example, the instructions included in the cardiac function analyzer **102** program the processor **410** to configure preference information and determine the heart rate of the patient using the preference information. In other examples, the cardiac function analyzer **102** may be an application-specific integrated circuit (ASIC) that is coupled to the sensor interface **414** and tailored to determine the heart rate of the patient. Thus, examples of the cardiac function analyzer **102** are not limited to a particular hardware or software implementation. In addition, particular examples of the processes that the cardiac function analyzer **102** is configured to perform are discussed further below with reference to FIGS. 2-6.

[0038] The preference information **104** includes data that describes parameters used by the cardiac function analyzer **102** during its analysis of ECG signals. More particularly, according to the illustrated example, the preference information **104** identifies one or more channels from which the cardiac function analyzer **102** receives ECG signals. In this example, the preference information **104** also includes information that ranks each channel relative to the other identified channels. As is discussed further below, the cardiac function analyzer **102** uses this ranking information to resolve conflicts generated from the interpretation of two or more ECG signals received via the identified channels.

[0039] In some examples, the preference information **104** also includes information indicating one or more preferred rate detectors for each channel. In these examples, the cardiac function analyzer **102** uses the preferred rate detectors of each channel to interpret the ECG signal received from each channel. In other examples, the preference information **104** includes an association that groups channel and rate detector preference information into individual profiles. In these examples, the preference information **104** also includes data that indicates an active profile that is used by the cardiac function analyzer **102** to analyze ECG signals. These examples provide the added advantage of easily configuring channel and rate detector information preferences simply by changing the indicator of the active profile from the active profile to another profile.

[0040] The preference information **104** may be stored in any logical construction capable of storing information on a computer readable medium including, among other structures, flat files, indexed files, hierarchical databases, relational databases or object oriented databases. In addition, various examples organize the preference information **104** into particularized and, in some cases, unique structures to perform the functions disclosed herein. In these examples, the data structures are sized and arranged to store values for particular types of data.

[0041] In some examples, the components disclosed herein, such as the cardiac function analyzer **102**, may read parameters that affect the functions performed by the com-

ponents. These parameters may be physically stored in any form of suitable memory including volatile memory, such as RAM, or nonvolatile memory, such as a magnetic hard drive. In addition, the parameters may be logically stored in a propriety data structure, such as a database or file defined by a user mode application, or in a commonly shared data structure, such as an application registry that is defined by an operating system. In addition, some examples provide for both system and user interfaces, as may be implemented using the user interface **418**, that allow external entities to modify the parameters and thereby configure the behavior of the components.

Preferential ECG Signal Processing

[0042] FIG. 2 illustrates a process **200** for configuring the preference information **104** according to one example. As shown, the process **200** includes acts of receiving an ECG signal from each channel, determining a confidence level for each channel and establishing preferences. The process **200** begins at **202**.

[0043] In act **204**, an electrode system, such as the electrode system **100** discussed above, receives one or more ECG signals via one or more channels. According to one example, the electrode system receives ECG signals from a front-to-back channel and from a side-to-side channel. The front-to-back channel includes an electrode positioned on the chest of the patient and another electrode positioned on the back of the patient. The side-to-side channel includes an electrode positioned on the left side of the chest and another electrode positioned on the right side of the patient. Other examples may employ additional, or fewer, electrodes or electrodes located in other positions on the patient's body. In addition, act **204** may include a variety of acts designed to render an accurate interpretation of the ECG signal. For instance, in one example, a control unit, such as the control unit **30** discussed above with reference to FIG. 1, filters or otherwise manipulates the ECG signal to remove or lower the effect of noise generated by sources other than the patient's heart, such as other muscle movement or electrical disturbances near the patient.

[0044] In act **206**, the filtered ECG signals are analyzed to determine a confidence level for the interpretation of each filtered ECG signal. According to the illustrated example, the filtered ECG signal of each channel is compared to benchmark information to determine a level of confidence that interpretations of the filtered ECG signal are accurate. As discussed further below, this benchmark information may include benchmark ECG signals and benchmark values that characterize attributes of a normal cardiac cycle.

[0045] The source of the benchmark information varies from example to example. For instance, according to one example, a standardized representation of a normal sinus rhythm, such as the ECG signal illustrated in FIG. 3, is utilized as a benchmark ECG signal. In other examples, the benchmark ECG signal includes idiosyncratic characteristics of a particular patient's normal rhythm. In these examples, the benchmark ECG signal may be received by the control unit via one or more designated channels. For instance, in one of these examples, the control unit records a benchmark ECG signal when the electrode system is initially prescribed and fitted to a patient. In addition, according to these examples, the benchmark ECG signal may adapt over time. For instance, the cardiac function analyzer **102** may adjust the benchmark ECG signal to

match a composite ECG signal made up of filtered ECG signals falling within a moving window of a predefined duration. Alternatively, the benchmark ECG signal may be replaced by a newly received ECG signal with desirable characteristics such as higher amplitudes, less noise or that more closely match the normal rhythm of the patient.

[0046] Like the source of the benchmark ECG signal, the comparison operation used within the act **206** to determine the quality of interpretations of the filtered ECG signals varies between examples. In some examples, the morphology of the filtered ECG signal is compared to the morphology of the benchmark ECG signal. In these examples, the level of confidence associated with the channel that received the filtered ECG signal is directly related to the fit of the filtered ECG signal to the benchmark ECG signal. More particularly, according to one example, a full cardiac cycle that includes P, Q, R, S and T waves is interpreted from the filtered signal. In this example, a deviation from the interpreted benchmark wave sequence of P, Q, R, S and T waves, such as one or more repeated R waves, indicates a potential double counting of a heartbeat and results in a decreased level of confidence associated with the channel. In some examples, this comparison operation is conducted by a user, such as a physician, through visual inspection.

[0047] In another example, the heart rate detected by each combination of channel and heart rate detection method is compared to the actual heart rate as determined by a user, such as a physician. In this example, the heart rate detection methods used may include derivative-based QRS detectors, spectrum analyzers or axis analyzers, as described in commonly owned U.S. Pat. No. 5,944,669 (hereinafter referred to as the “669 patent”), which is incorporated herein by reference in its entirety. In this example, the level of confidence associated with the channel receiving the filtered ECG signal is inversely related to any difference between the heart rate detected and the actual heart rate. In addition, a level of confidence for each combination of channel and heart rate detection method may be established using this example.

[0048] In other examples, the refractory period is automatically configured to more closely fit the duration of detected QRS complexes. According to these examples, a valid QRS complex is identified by matching the morphology of the benchmark ECG signal to the morphology of the filtered ECG signal. In these examples, the refractory period is adjusted (in most cases lengthened) to encompass the duration of the valid QRS complex while the morphology of the benchmark ECG signal continues to match the morphology of the filtered ECG signal. In at least one example, an axis analyzer, such as the axis analyzer described in the ‘669 patent, identifies the valid QRS complex and monitors the filtered ECG signal to ensure that a match between the filtered ECG signal and the benchmark ECG is maintained. Channels with refractory periods adjusted in this manner are associated with a high level of confidence.

[0049] In act **208**, preferences are established for determining the cardiac function of a given patient. In one example, preference information, such as preference information **104**, is stored within the data storage **412**. This preference information includes a ranking of channels based on the results of the comparison performed in act **206** with channels having a higher level of confidence being ranked above channels with a lower level of confidence. In another example, the preference information also ranks heart rate

detection methods by channel, with heart rate detection methods having a higher level of confidence being ranked above heart rate detection methods having a lower level of confidence. In other examples, the ranking information may include the strength of the fit detected between the filtered ECG signal and the benchmark ECG signal or the output of the axis analyzer. In some of these examples, the strength of the fit reflects any differences in timing between interpreted ECG signal characteristics, such as QRS complexes, and interpreted benchmark ECG signal characteristics. According to a variety of examples, act **208** can be repeated at periodic intervals or as requested by a user, such as a patient or a physician. The process **200** ends at **210**.

[0050] Processes in accord with the process **200** configure an electrode system, such as the electrode system **100** discussed above, to include a set of preferences for processing ECG signals. According to some examples, the process **200** is conducted by an electrode system, such as the electrode system **100** discussed above. In these examples, the data storage **412** includes the benchmark information and the cardiac function analyzer **102** conducts the acts included in the process **200**. In other examples, some aspects of the process **200** are conducted by users. For instance, in one example, a user, such as a physician, performs the act **206** by determining the confidence level associated with each channel and heart rate detection method and if the user notices that the amplitude or signal to noise ratio of a particular channel is superior, the confidence level associated with that channel is increased. Further, in this example, the user performs the act **208** by storing the preference information in the electrode system, via a user interface, such as the user interface **418**.

[0051] According to another example, the user, such as a physician, performs the act **208** by causing the preference information to be stored on the control unit of an electrode system via a network interface. In this example, a processor included in the control unit of the electrode system, such as the processor **410** of the control unit **30**, is coupled to a network interface such as the network interface **206** described in U.S. Pat. No. 8,904,214, titled “SYSTEM AND METHOD FOR CONSERVING POWER IN A MEDICAL DEVICE,” issued Dec. 2, 2014, which is incorporated by reference herein in its entirety.

[0052] FIG. 4 illustrates an exemplary process **400** for interpreting ECG signals using preference information. As shown, the process **400** includes acts of retrieving preferences, acquiring ECG signals from preferred channels and processing the ECG signals according to the retrieved preferences. The process **400** begins at **402**.

[0053] In act **404**, the cardiac function analyzer **102**, discussed above, retrieves preference information, such as preference information **104** discussed above, from data storage. According to one example, the preference information includes information ranking the channels through which ECG signals can be received and further indicating a preferred set of ranked channels. In another example, the preference information includes information ranking the heart rate detection methods available for each ranked channel and indicating a preferred set of heart rate detection methods.

[0054] In act **406**, the cardiac function analyzer **102** acquires ECG signals from each of the preferred set of ranked channels. The electrode system may perform a variety of acts designed to render an accurate interpretation

of the ECG signal. For instance, in one example, a control unit, such as the control unit **30** discussed above with reference to FIG. **1**, filters or otherwise manipulates the ECG signal to remove or lower the effect of noise generated by sources other than the patient's heart, such as other muscle movement or electrical disturbances near the patient.

[0055] In act **408**, the cardiac function analyzer **102** processes the ECG signals to determine a heart rate for the patient. FIG. **5** illustrates an exemplary process **500** in accord with act **408**. As shown, the process **500** begins at **502**.

[0056] In act **504**, the cardiac function analyzer **102** processes a portion of the filtered ECG signal received by each preferred channel using one or more of the heart rate detection methods discussed above with reference to the process **200**. For instance, the cardiac function analyzer **102** may utilize conventional derivative-based QRS detectors, axis detectors or others. According to a particular example discussed further below, when the cardiac cycle appears to be in a normal sinus rhythm, the cardiac function analyzer **102** determines a heart rate using both a QRS detector and an axis detector. In this example, the axis detector indicates the occurrence of a heartbeat when a peak in the magnitude indicated by the axis detector corresponds to a zero phase crossing. In another example, the axis detector may concurrently compare the quality of the fit of multiple ECG signals coming from multiple channels to a benchmark ECG and may use the heart rate determined in this manner provided that the quality of the fit between the benchmark ECG signal and the multiple ECG signals meets a predetermined value. In still another example, a single channel fit is performed using the axis detector. In these examples that utilize an axis detector, the quality of the fit is determined by summing errors calculated between samples of the benchmark ECG signal and one or more ECG signals over an identified period.

[0057] In act **506**, if the results of these methods agree (for example, if each method detects a single heartbeat from the portion of the interpreted ECG signal) then the cardiac function analyzer **102** proceeds to act **510**. Otherwise, the cardiac function analyzer **102** proceeds to act **508**. In act **508**, the cardiac function analyzer **102** resolves conflicts between channels and heart rate detection methods. The particular conflict resolution procedure employed varies from example to example and examples are not limited to a particular approach to resolving conflicting results between channels or combinations of channels and heart rate detection methods. For instance, according to one example, the cardiac function analyzer **102** resolves conflicts that involve multiple channels in favor of the highest ranking preferred channel. In another example, the cardiac function analyzer **102** resolves conflicts that involve multiple channels and heart rate detectors in favor of the result indicated by a majority of the channel and heart rate detector combinations. Continuing with the particular example discussed above involving the QRS and axis detectors, conflicts between QRS detector results on separate channels are resolved in favor of the channel with a result that agrees with the axis detector result.

[0058] In act **510**, if all of the interpretations, or the favored interpretations, of the ECG signals indicate that a heartbeat has occurred, the cardiac function analyzer **102** records the occurrence of a heartbeat in act **512**. Otherwise, the cardiac function analyzer **102** determines if an interrup-

tion in monitoring is about to commence, such as an interruption caused by shutdown of the electrode system, in act **514**. If so, the cardiac function analyzer ends the process **500** at **516**. Otherwise, the cardiac function analyzer **102** returns to act **504** and the process **500** continues.

[0059] Examples in accord with process **500** enable an electrode system to more accurately track patient heart rate. More accurate heart rate tracking results in several benefits. These benefits include more accurate patient historical information and generation of fewer falsely indicated arrhythmias. Fewer false arrhythmias, in turn, may result in avoidance of unnecessary alarms and delivery of therapy to a patient, thereby increasing the runtime between charges of the electrode system and avoiding unnecessary patient discomfort.

[0060] Each of the processes disclosed herein depicts one particular sequence of acts in a particular example. The acts included in each of these processes may be performed by, or using, an electrode system specially configured as discussed herein. Although described herein in association with an electrode system of a wearable defibrillator such as the LIFEVEST Cardioverter defibrillator, embodiments disclosed herein may be used with any electrode system, including conventional stick-on adhesive electrodes, dry capacitive ECG electrodes, radio transparent electrodes, etc. Some acts are optional and, as such, may be omitted in accord with one or more examples. Additionally, the order of acts can be altered, or other acts can be added, without departing from the scope of the systems and methods discussed herein. In addition, as discussed above, in at least one example, the acts are performed on a particular, specially configured machine, namely an electrode system configured according to the examples disclosed herein.

Usage Scenario

[0061] FIG. **6** illustrates two exemplary idiosyncratic ECG signals **600** and **602** received by an exemplary electrode system. As shown, the ECG signal **600** was acquired via a side-to-side (SS) channel and includes QRS complex **604**. The ECG signal **602** was acquired via a front-to-back (FB) channel and includes QRS complex **606**. As illustrated, the ECG signal **600** may be double counted by conventional derivative-based QRS complex detectors because the QRS complexes presented within the ECG signal **600**, such as the portion of the ECG signal indicated by reference number **604**, are elongated and exceed the default configuration of the refractory period. Thus, conventional derivative-based QRS complex detectors may detect a first QRS complex at the onset of the QRS complex **604** and detect a second QRS complex near the end of the QRS complex **604** after the refractory period has expired.

[0062] According to one example, a user, such as a physician, may perform act **206** of process **200** and thereby determine that the SS channel is susceptible to double counting by comparing the morphology of the ECG signal acquired via the SS channel to an ECG signal representative to a normal sinus rhythm. Further, the user may perform act **208** by configuring preference information to rank the FB channel higher than the SS channel. After receiving this preference information and during the execution of process **400**, the exemplary electrode system favors the FB channel over the SS channel if the two channels yield differing heart rates. This approach results in a decreased likelihood of heartbeat double counting because the QRS complexes

displayed within the FB channel do not extend beyond the programmed refractory period and are, therefore, less likely to be double counted.

[0063] Having thus described several aspects of at least one embodiment of this invention, it is to be appreciated various alterations, modifications, and improvements will readily occur to those skilled in the art. Such alterations, modifications, and improvements are intended to be part of this disclosure, and are intended to be within the scope of the invention. Accordingly, the foregoing description and drawings are by way of example only.

What is claimed is:

1. A medical device comprising:
 - at least one sensing electrode configured to be disposed on a patient;
 - a control unit comprising:
 - a sensor interface coupled to the at least one sensing electrode and configured to receive at least one electrocardiogram (ECG) signal from the at least one sensing electrode;
 - a memory storing a configurable parameter indicating at least one preferred heart rate detection method;
 - at least one processor coupled to the sensor interface and the memory, the least one processor being configured to implement a cardiac function analyzer to process the at least one ECG signal to determine a heart rate of the patient using two or more heart rate detection methods, to identify a difference in the heart rate of the patient as determined by the two or more heart rate detection methods, to retrieve the configurable parameter, and to resolve the difference in favor of the at least one preferred heart rate detection method.
2. The medical device of claim 1, wherein the medical device is ambulatory.
3. The medical device of claim 1, wherein the at least one preferred heart rate detection method has at least one refractory period that is different from a refractory period of a heart rate detection method of the two or more heart rate detection methods.
4. The medical device of claim 1, wherein the two or more heart rate detection methods comprise at least one of a QRS detector, a spectrum analyzer, and an axis analyzer.
5. The medical device of claim 1, wherein the cardiac function analyzer is further configured to identify automatically the at least one preferred heart rate detection method during operation of the medical device.
6. The medical device of claim 5, wherein the cardiac function analyzer is configured to identify the at least one preferred heart rate detection method by comparing at least one signal interpretation derived from the at least one preferred heart rate detection method to a benchmark.
7. The medical device of claim 6, wherein the benchmark comprises a signal interpretation of at least one of a normal cardiac rhythm and the patient's cardiac rhythm.
8. The medical device of claim 7, wherein the patient's cardiac rhythm is recorded during initial prescription and fitting of the medical device.
9. The medical device of claim 8, wherein the cardiac function analyzer is further configured to adjust the benchmark to match a composite ECG signal summarizing historical ECG signals of the patient.

10. The medical device of claim 9, wherein the historical ECG signals fall within a moving window of a predefined duration.

11. The medical device of claim 1, wherein the at least one sensing electrode comprises a plurality of sensing electrodes.

12. The medical device of claim 11, wherein the cardiac function analyzer is further configured to identify at least one of one or more pairings of the plurality of sensing electrodes and one or more refractory periods for the at least one preferred heart rate detection method.

13. The medical device of claim 12, wherein the cardiac function analyzer is further configured to adjust the one or more refractory periods to avoid differences due to abnormal T waves.

14. The medical device of claim 12, wherein the memory stores a plurality of patient profiles and the cardiac function analyzer is further configured to store, within a patient profile of the plurality of patient profiles, at least one of one or more indications of the one or more pairings, one or more indications of the one or more refractory periods, and the at least one preferred heart rate detection method.

15. The medical device of claim 12, further comprising a network interface configured to receive preference information descriptive of at least one of the one or more pairings, the one or more refractory periods, and the at least one preferred heart rate detection method.

16. The medical device of claim 1, wherein the at least one preferred heart rate detection method comprises a plurality of preferred heart rate detection methods and the cardiac function analyzer is configured to resolve the difference in favor of a highest ranking preferred heart rate detection method of the plurality of preferred heart rate detection methods.

17. The medical device of claim 1, wherein the at least one preferred heart rate detection method comprises a plurality of preferred heart rate detection method and the cardiac function analyzer is configured to resolve the difference in favor of a majority of the plurality of preferred heart rate detection methods.

18. A method of monitoring electrocardiogram (ECG) signals using a medical device comprising a memory and at least one sensing electrode, the method comprising:

- storing, in the memory, a configurable parameter indicating at least one preferred heart rate detection method of a plurality of heart rate detection methods;
- receiving at least one ECG signal via the at least one sensing electrode;
- processing the at least one ECG signal to determine a heart rate of a patient using two or more heart rate detection methods of the plurality of heart rate detection methods;
- detecting a difference in the heart rate as determined by the two or more heart rate detection methods; and
- resolving the difference by retrieving the configurable parameter and resolving the difference in favor of the at least one preferred heart rate detection method.

19. The method of claim 18, wherein processing the at least one ECG signal comprises processing the at least one ECG signal using at least two of a QRS detector, a spectrum analyzer, and an axis analyzer.

20. A non-transitory computer readable medium storing sequences of instruction for monitoring electrocardiogram (ECG) signals comprising instructions configured to instruct at least one processor to:

- store a configurable parameter indicating at least one preferred heart rate detection method of a plurality of heart rate detection methods;
- receive at least one ECG signal via at least one sensing electrode;
- process the at least one ECG signal to determine a heart rate of a patient using two or more heart rate detection methods of the plurality of heart rate detection methods;
- detect a difference in the heart rate as determined by the two or more heart rate detection methods; and
- resolve the difference by retrieving the configurable parameter and resolving the difference in favor of the at least one preferred heart rate detection method.

21. The computer readable medium of claim **20**, wherein the instructions configured to instruct the at least one processor to process the at least one ECG signal comprise instructions configured to instruct the at least one processor to process the at least one ECG signal using at least two of a QRS detector, a spectrum analyzer, and an axis analyzer.

22. An ambulatory medical device comprising:

- a plurality of electrodes disposed about a patient's body; and

a control unit including:

- a sensor interface coupled to the plurality of electrodes and configured to receive a plurality of electrocardiogram (ECG) signals from a plurality of pairings of the plurality of electrodes;
- a memory storing a configurable parameter indicating at least one preferred pairing of the plurality of pairings; and

at least one processor coupled to the sensor interface and the memory, the least one processor implementing a cardiac function analyzer to process the plurality of ECG signals to detect heartbeats of the patient, to identify a difference in the heartbeats detected by two or more pairings of the plurality of pairings, to retrieve the configurable parameter, and to resolve the difference in favor of the at least one preferred pairing.

23. The ambulatory medical device of claim **22**, wherein the cardiac function analyzer is further configured to identify at least one of one or more detection methods and one or more refractory periods for the at least one preferred pairing.

24. The ambulatory medical device of claim **23**, wherein the cardiac function analyzer is further configured to adjust the one or more refractory periods to avoid differences due to abnormal T waves.

25. The ambulatory medical device of claim **23**, wherein the one or more detection methods comprise at least one of a QRS detector, a spectrum analyzer, and an axis analyzer.

26. The ambulatory medical device of claim **22**, wherein the at least one preferred pairing includes a plurality of preferred pairings and the cardiac function analyzer is configured to resolve the difference in favor of a highest ranking preferred pairing of the plurality of preferred pairings.

27. The ambulatory medical device of claim **22**, wherein the at least one preferred pairing includes a plurality of preferred pairings and the cardiac function analyzer is configured to resolve the difference in favor of a majority of the plurality of preferred pairings.

28. An ambulatory medical device comprising:

- a plurality of electrodes disposed about a patient's body; and

a control unit including:

- a sensor interface coupled to the plurality of electrodes and configured to receive a first electrocardiogram (ECG) signal from a first pairing of the plurality of electrodes and to receive a second ECG signal from a second pairing of the plurality of electrodes;
- a memory configured to store a configurable parameter indicating at least one preferred pairing of the first pairing and the second pairing; and

at least one processor coupled to the sensor interface and the memory and configured to process the first ECG signal to determine a first signal interpretation of a physical condition of the patient, to process the second ECG signal to determine a second signal interpretation of the physical condition of the patient, to determine a first level of confidence in the first signal interpretation, to determine a second level of confidence in the second signal interpretation, to determine that the first level of confidence is higher than the second level of confidence, and to store an indicator of the first pairing in the configurable parameter.

29. The ambulatory medical device of claim **28**, wherein the cardiac function analyzer is configured to:

- determine the first level of confidence by comparing the first signal interpretation to a benchmark; and
- determine the second level of confidence by comparing the first signal interpretation to the benchmark.

30. The ambulatory medical device of claim **29**, wherein the benchmark includes a signal interpretation of at least one of a normal cardiac rhythm and the patient's cardiac rhythm.

31. The ambulatory medical device of claim **30**, wherein the patient's cardiac rhythm is recorded during initial prescription and fitting of the ambulatory medical device.

32. The ambulatory medical device of claim **31**, wherein the cardiac function analyzer is further configured to adjust the benchmark to match a composite ECG signal summarizing historical ECG signals of the patient.

* * * * *

专利名称(译)	选择最优通道进行速率确定		
公开(公告)号	US20160317059A1	公开(公告)日	2016-11-03
申请号	US15/205584	申请日	2016-07-08
[标]申请(专利权)人(译)	卓尔医学产品公司		
申请(专利权)人(译)	ZOLL医疗公司		
当前申请(专利权)人(译)	ZOLL医疗公司		
[标]发明人	VOLPE SHANE S KAIB THOMAS E		
发明人	VOLPE, SHANE S. KAIB, THOMAS E.		
IPC分类号	A61B5/0428 A61B5/0245 A61B5/04 A61N1/04 A61B5/0432 A61B5/0472 A61N1/39 A61B5/0452 A61B5/00		
CPC分类号	A61B5/04288 A61B5/04525 A61B5/0245 A61B5/04012 A61B5/6804 A61B5/7221 A61B2560/0214 A61B5/0472 A61B5/7475 A61N1/3925 A61N1/046 A61N1/0484 A61B5/0432 A61B5/0006 A61B5/04085 A61B5/6805 A61B2560/0266 A61B2562/17 A61N1/0476 A61B5/04011 A61B5/046 A61B5/4836 A61B5/6801		
优先权	61/467599 2011-03-25 US		
其他公开文献	US10219717		
外部链接	Espacenet USPTO		

摘要(译)

根据至少一个示例，提供了一种移动医疗装置。该装置包括设置在患者身体周围的间隔开的位置处的多个电极和控制单元。控制单元包括传感器接口，存储器和处理器。传感器接口耦合到多个电极并且被配置为从多个电极中的第一对接收第一-ECG信号，并且从多个电极中的第二对接收第二-ECG信号。存储器存储指示优选配对的信息，优选配对是第一配对或第二配对。处理器耦合到传感器接口和存储器，并且被配置为解决第一-ECG信号和第二-ECG信号的解释之间的冲突，有利于优选配对。

