



US 20150150471A1

(19) **United States**
(12) **Patent Application Publication**
Balda

(10) **Pub. No.: US 2015/0150471 A1**
(43) **Pub. Date: Jun. 4, 2015**

(54) **SYSTEMS AND METHODS FOR
INTERELECTRODE DISTANCE
OPTIMIZATION IN A RETRACTABLE
MULTI-USE CARDIAC MONITOR**

A61B 5/00 (2006.01)
A61B 5/0432 (2006.01)
(52) **U.S. Cl.**
CPC *A61B 5/0408* (2013.01); *A61B 5/04325*
(2013.01); *A61B 5/044* (2013.01); *A61B*
5/0006 (2013.01)

(71) Applicant: **Medicomp, Inc.**, Melbourne, FL (US)

(72) Inventor: **Daniel Balda**, Indian Harbour Beach, FL (US)

(73) Assignee: **Medicomp, Inc.**, Melbourne, FL (US)

(21) Appl. No.: **14/616,801**

(22) Filed: **Feb. 9, 2015**

Related U.S. Application Data

(63) Continuation of application No. 13/111,517, filed on May 19, 2011, now Pat. No. 8,989,850.

(60) Provisional application No. 61/347,117, filed on May 21, 2010.

Publication Classification

(51) **Int. Cl.**
A61B 5/0408 (2006.01)
A61B 5/044 (2006.01)

(57) **ABSTRACT**

A retractable multi-use cardiac monitor is provided that includes a memory, and first and second sensing connectors positioned on outsides of first and second housings, respectively. The first and second sensing connectors are configured to detect electrocardiogram (ECG) signals that are stored onto the memory as ECG data. The second housing of the retractable multi-use cardiac monitor also includes a wire retractor configured to extend and retract a wire that connects the second and first housings, and that defines an interelectrode distance between the first and second sensing connectors. The retractable multi-use cardiac monitor further includes systems and methods for determining a length for the interelectrode distance that is optimum in terms of strength and fidelity of the detected ECG signals. The retractable multi-use cardiac monitor further includes a wireless radio configured to transmit a portion of the stored ECG data from the memory to a destination.

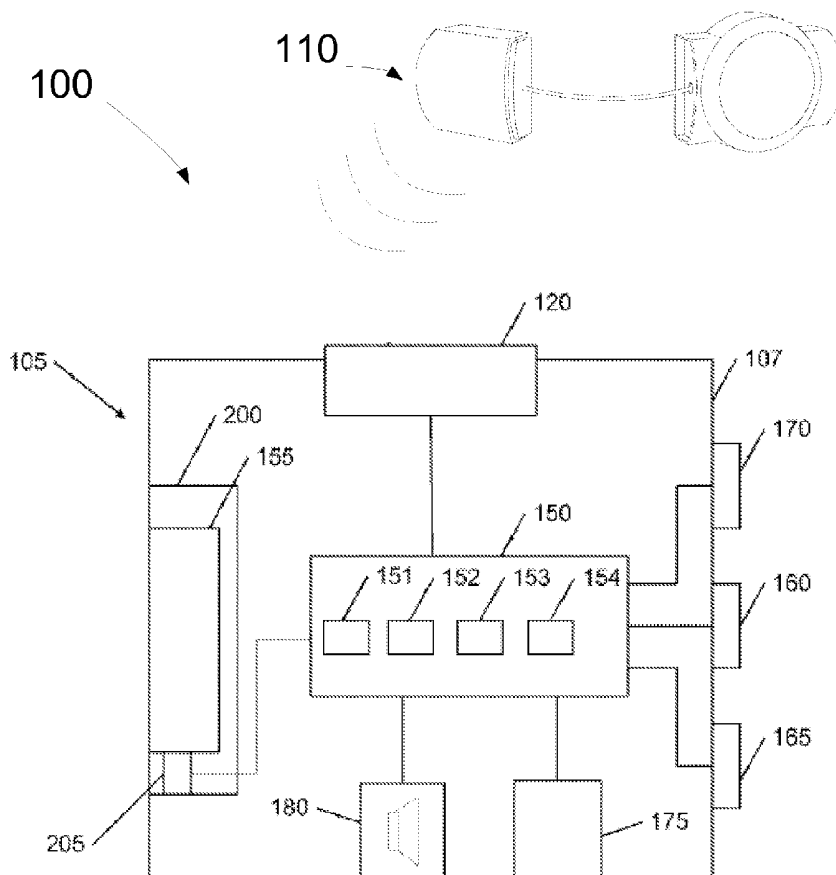

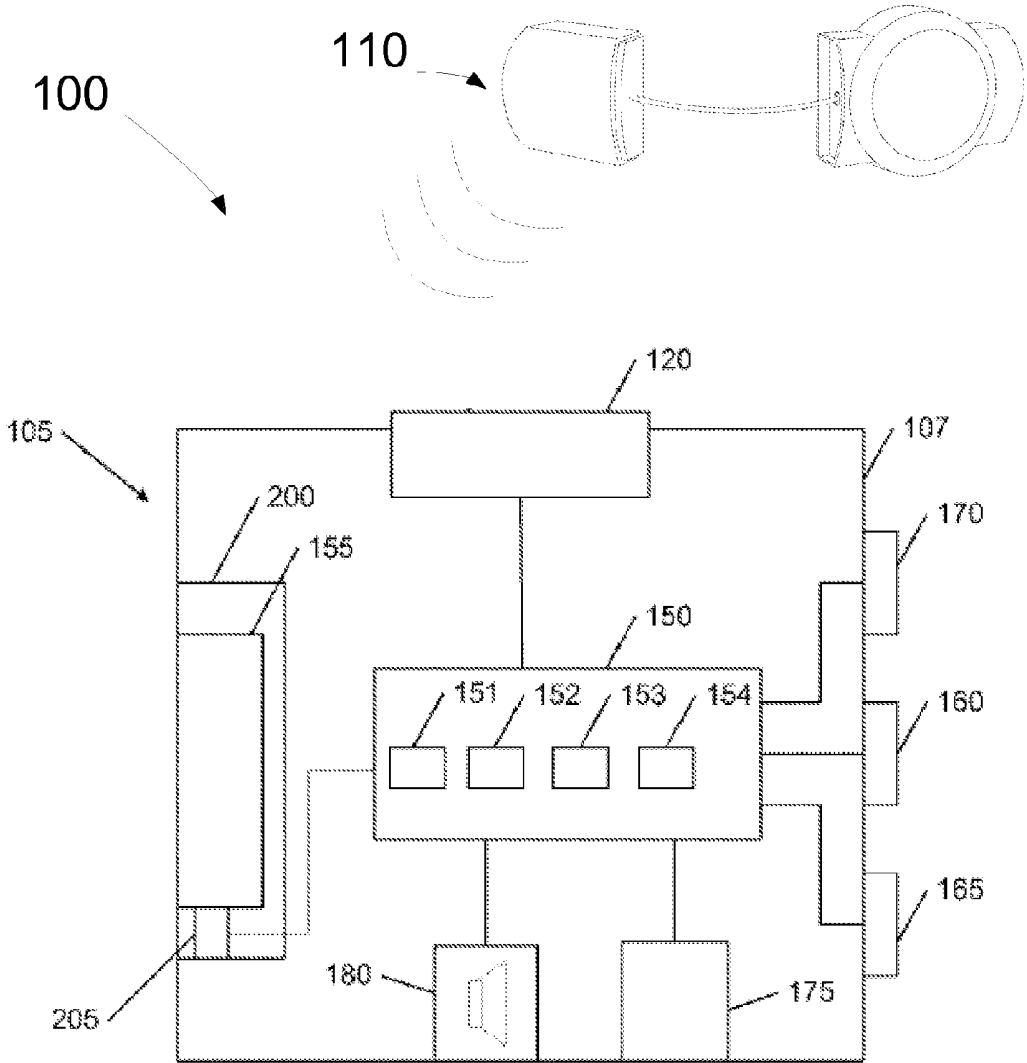

Figure 1

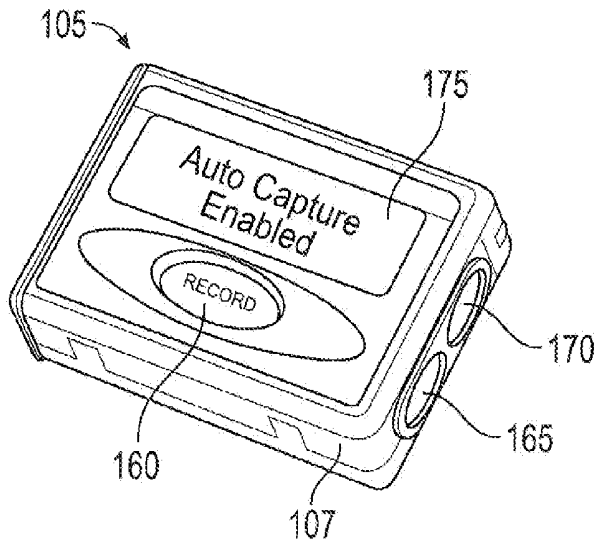

Figure 2A

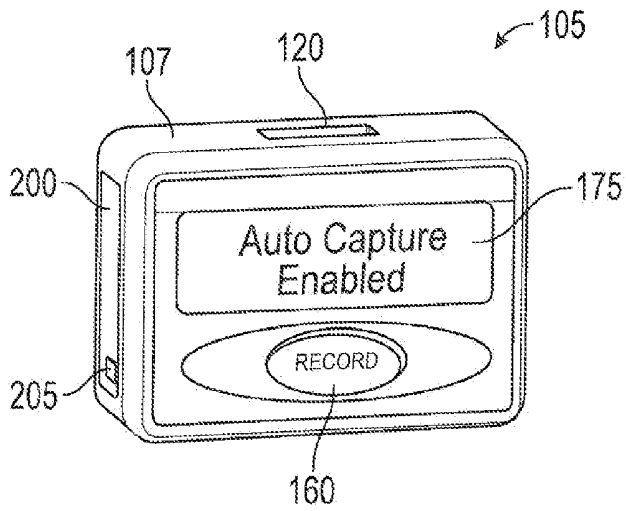

Figure 2B

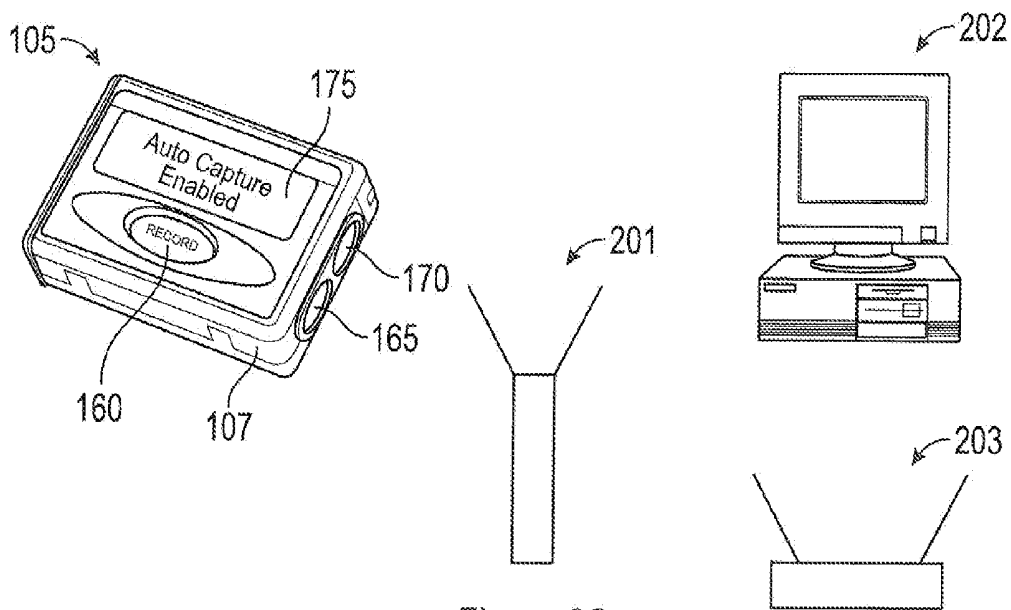

Figure 2C

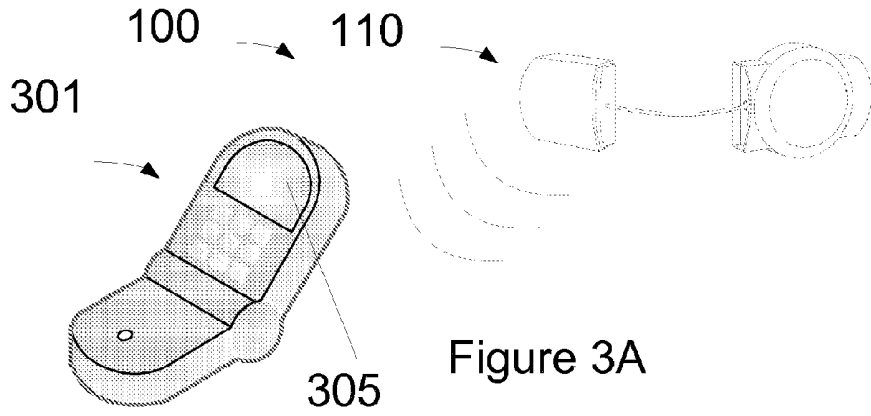

Figure 3A

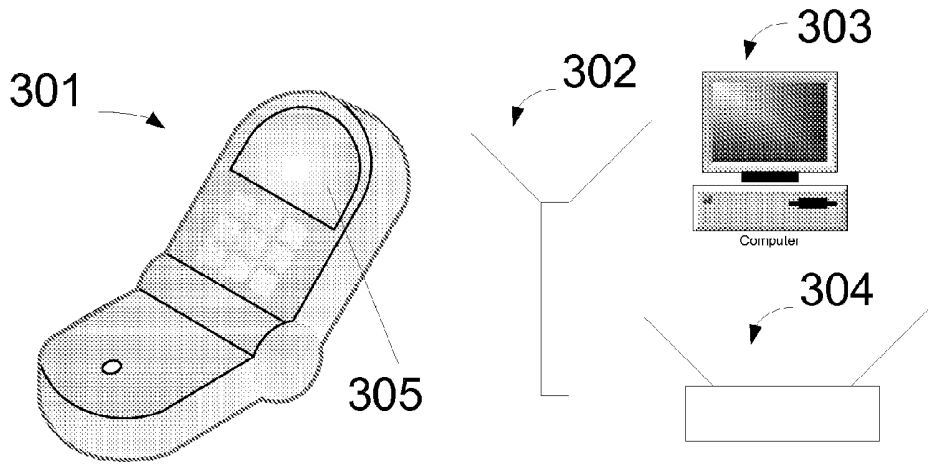

Figure 3B

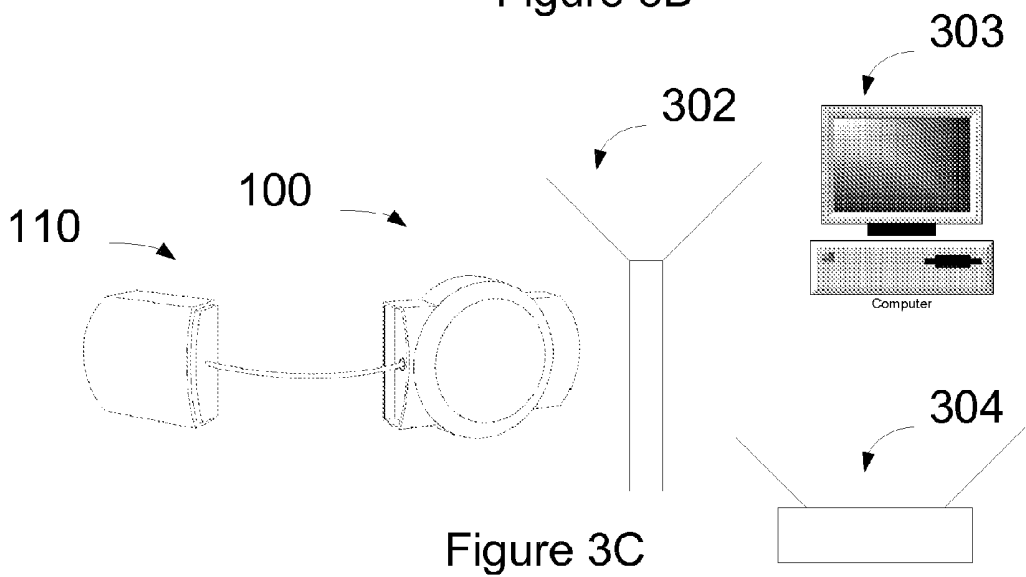

Figure 3C

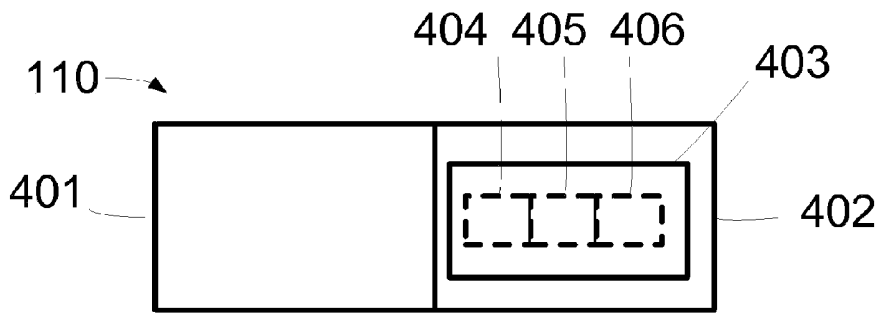

Figure 4

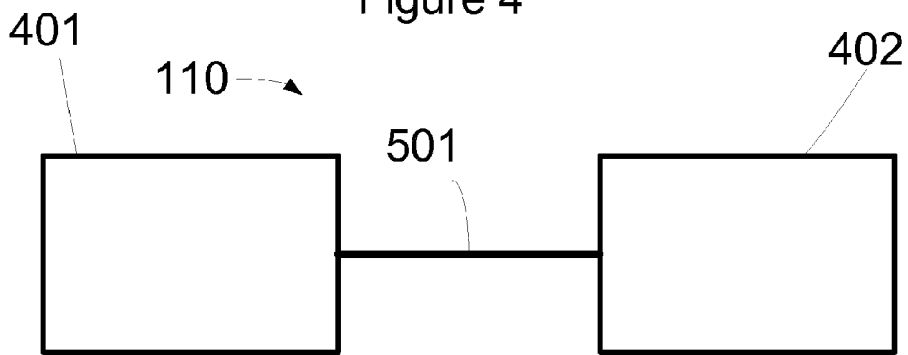

Figure 5

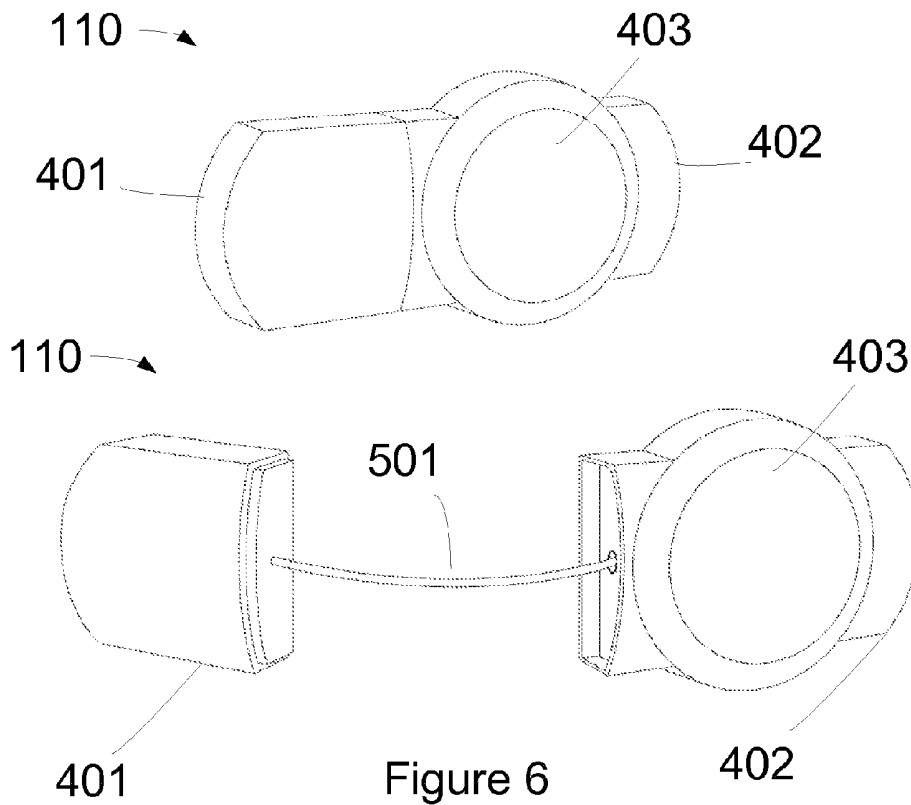

Figure 6

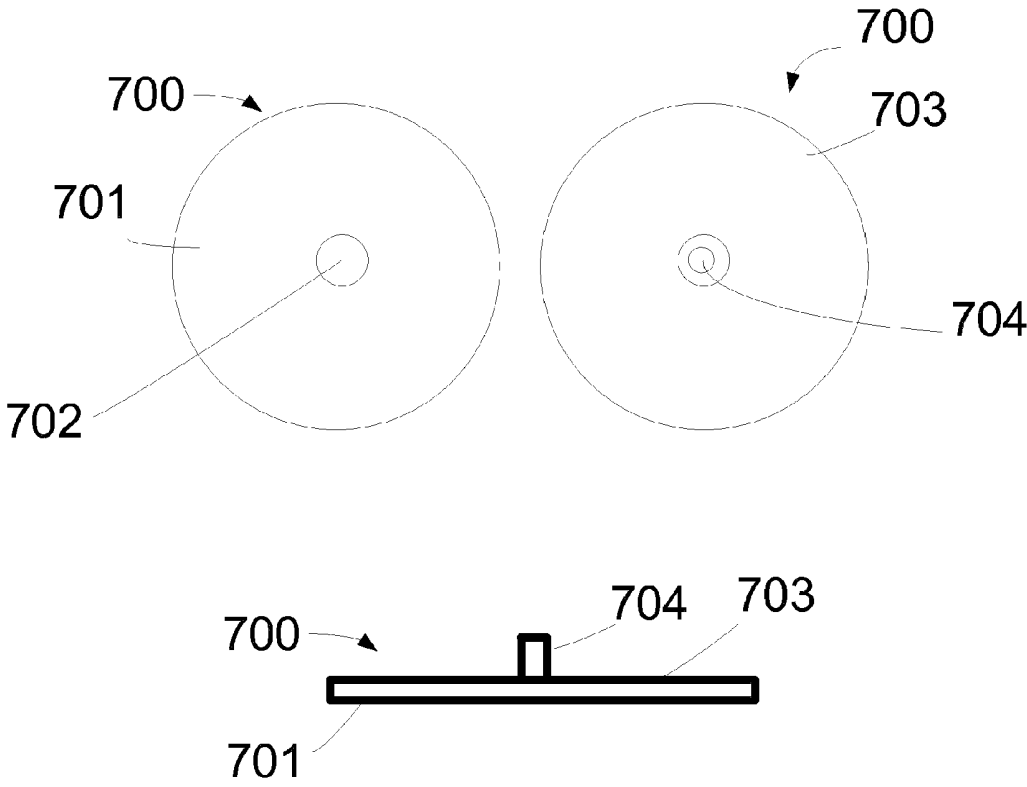

Figure 7

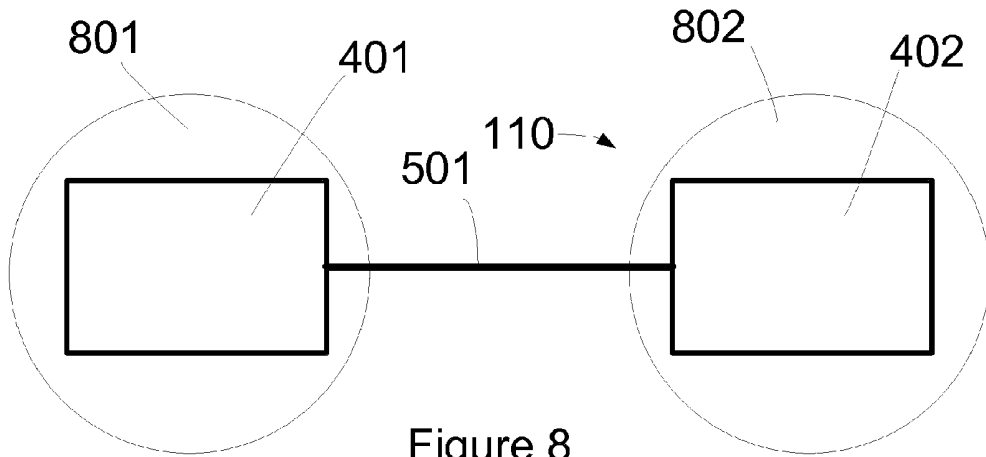

Figure 8

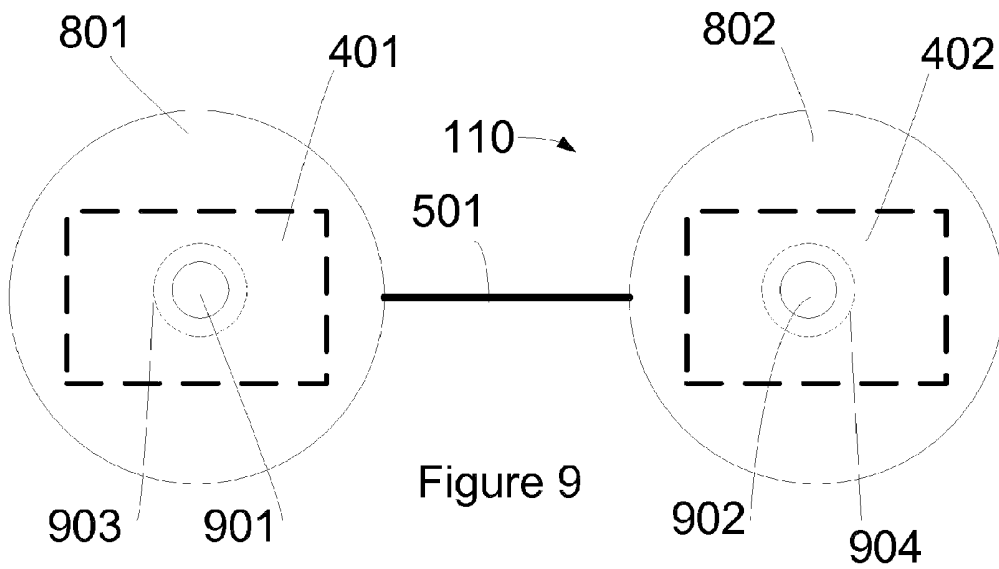

Figure 9

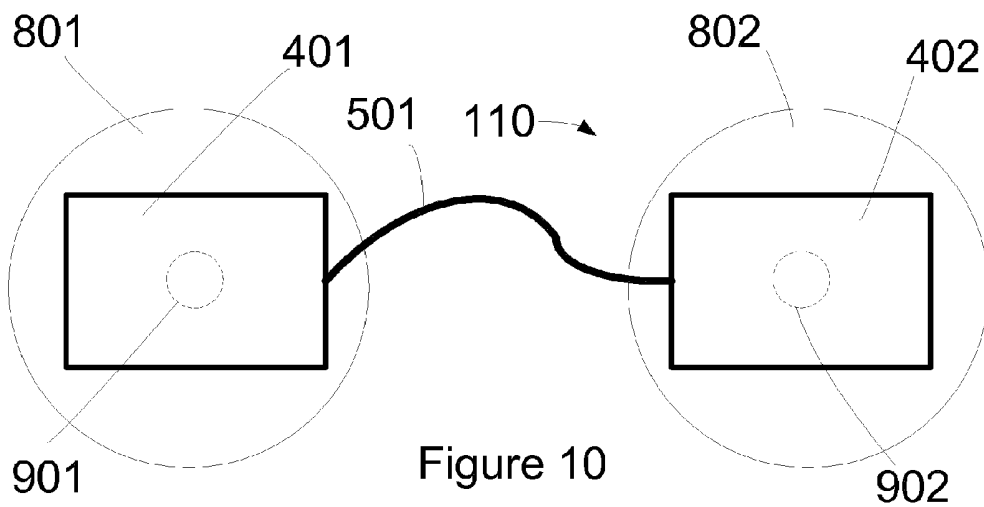
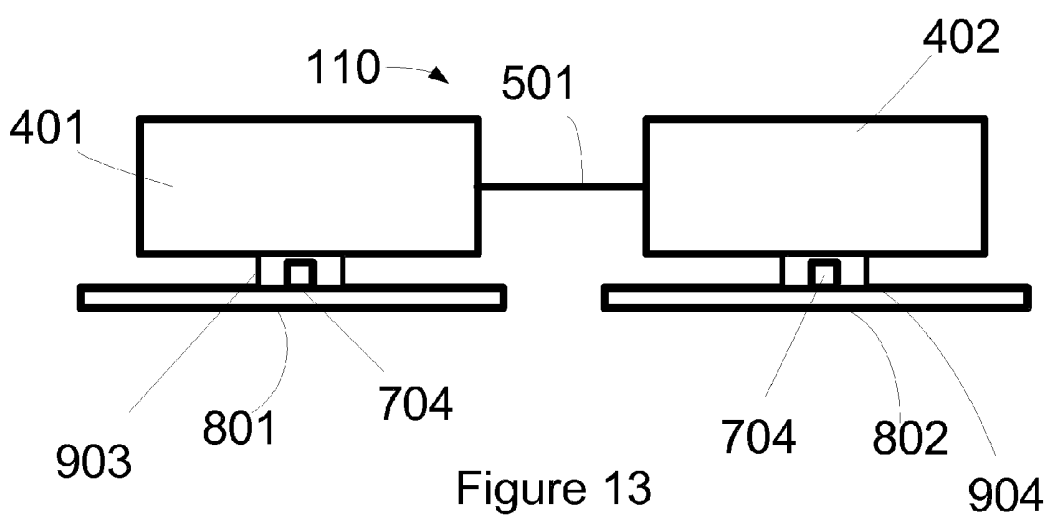
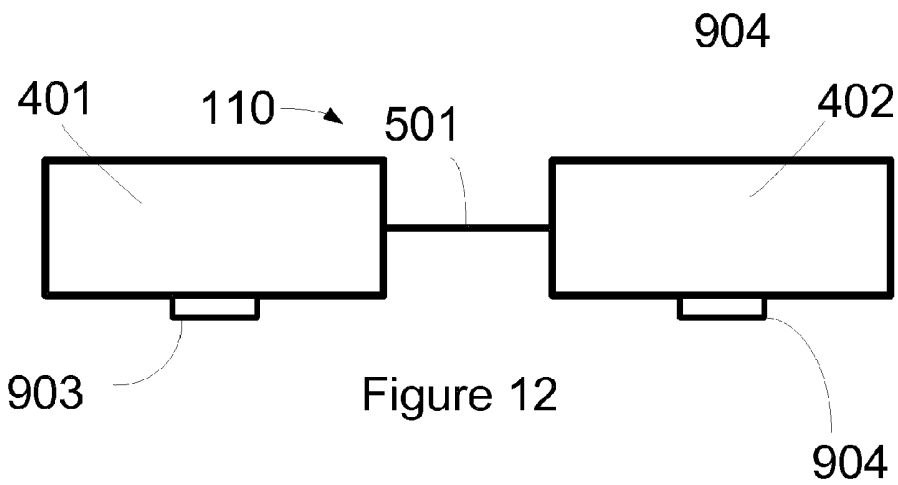
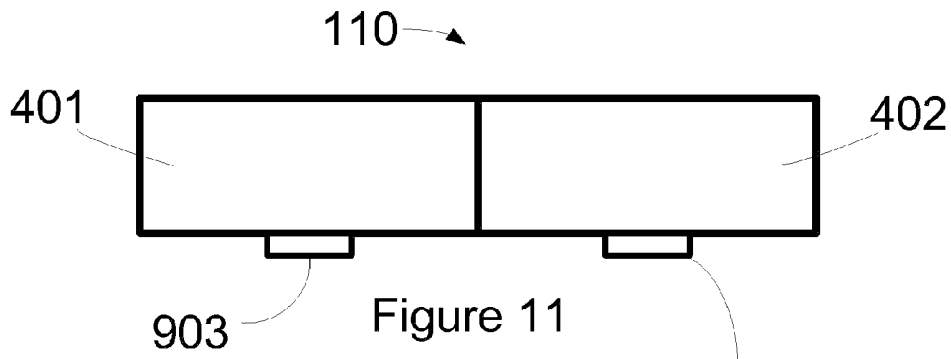

Figure 10



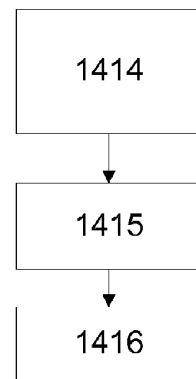
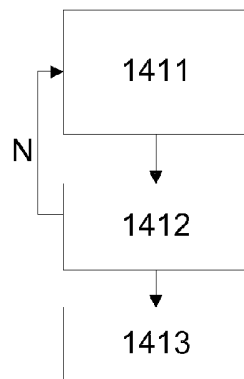
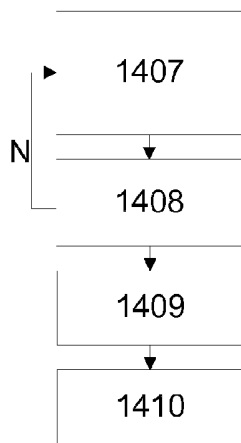
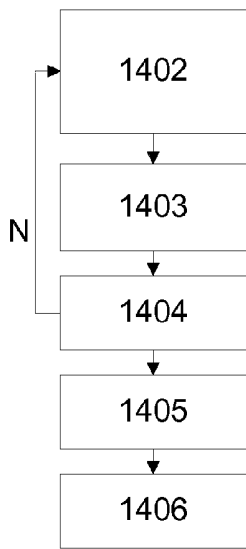
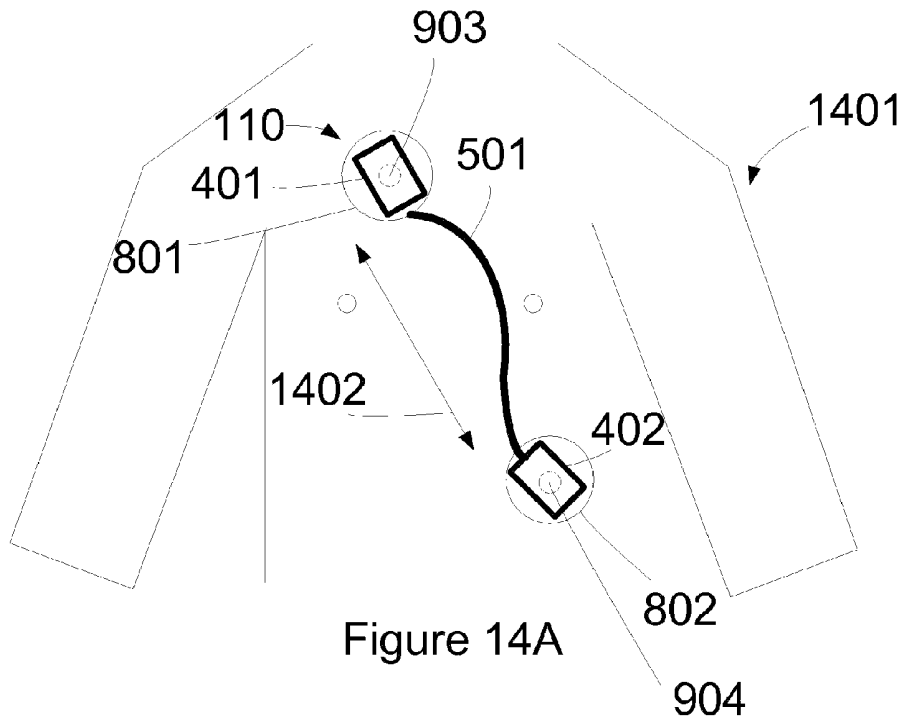
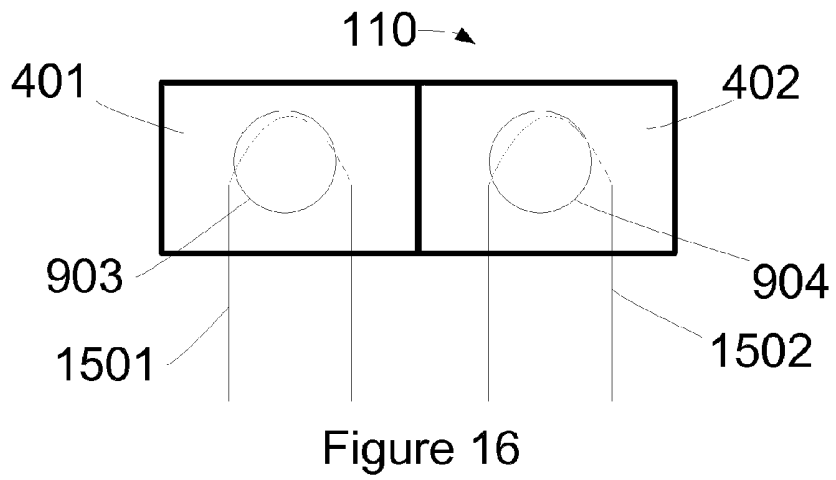
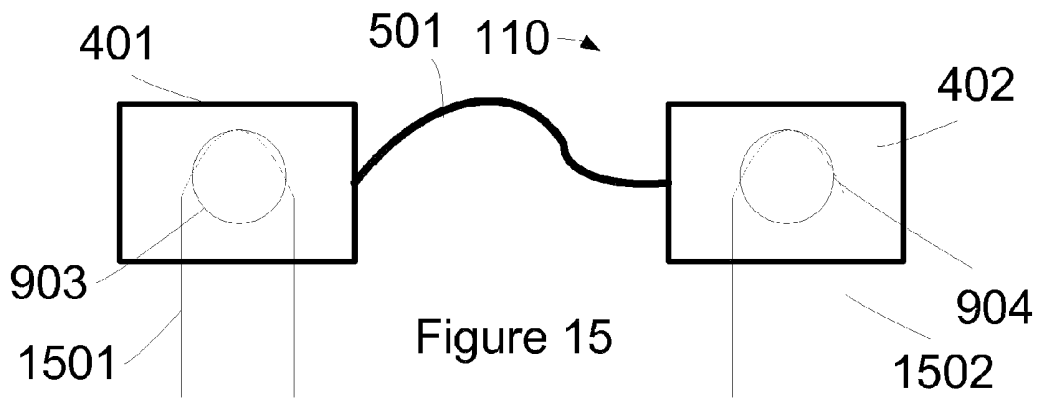
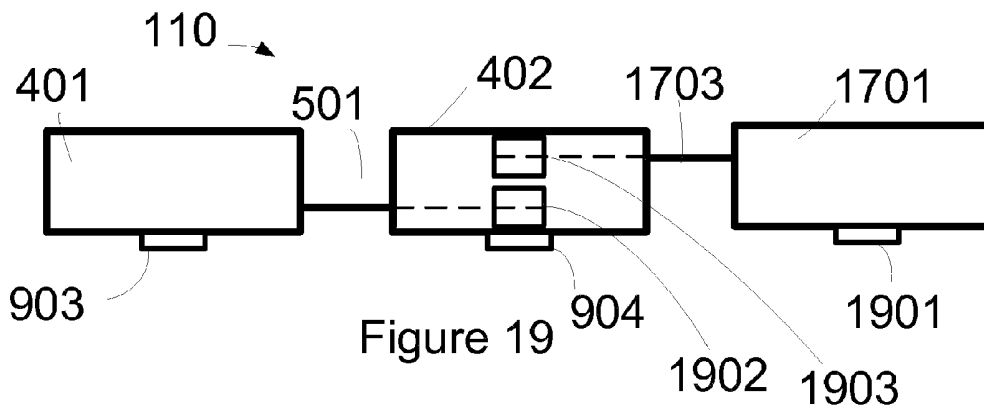
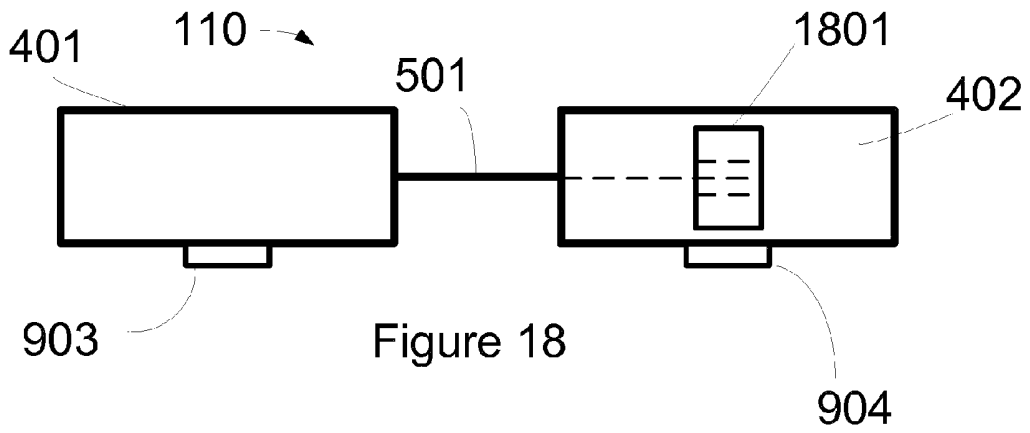
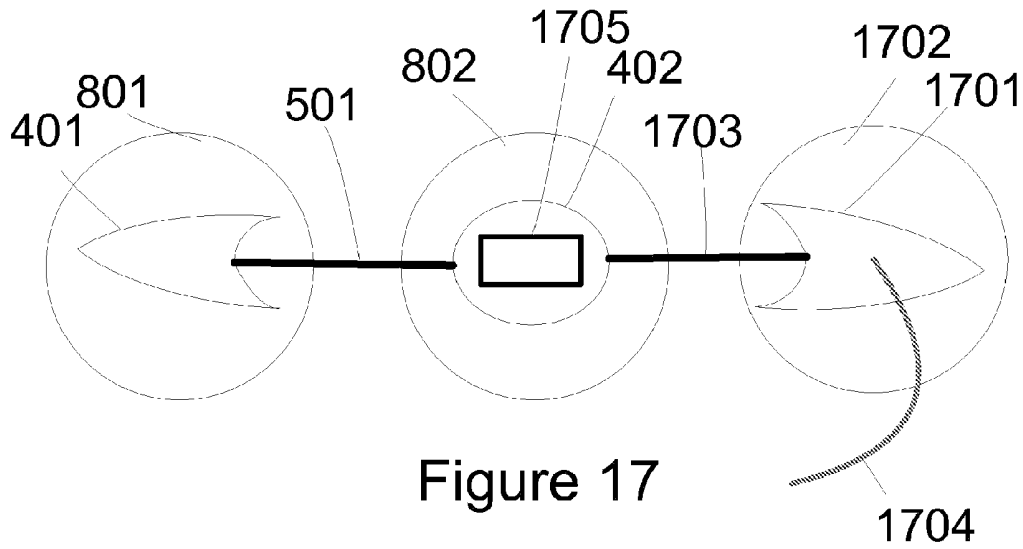

Figure 14B Figure 14C Figure 14D Figure 14E





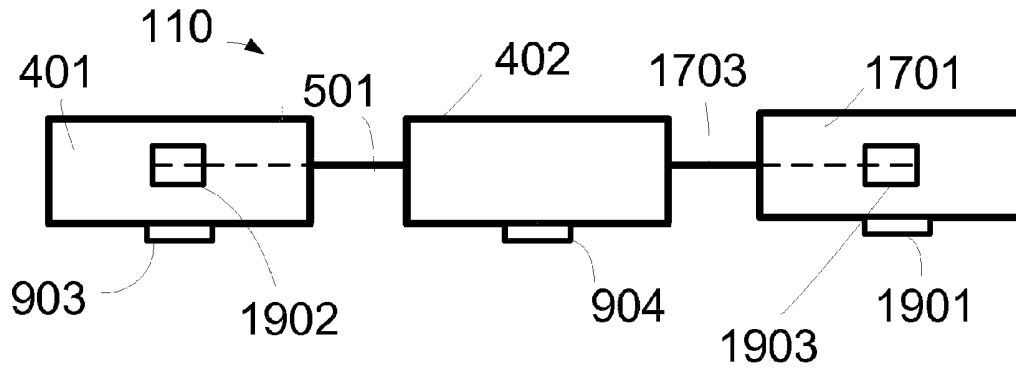

Figure 20

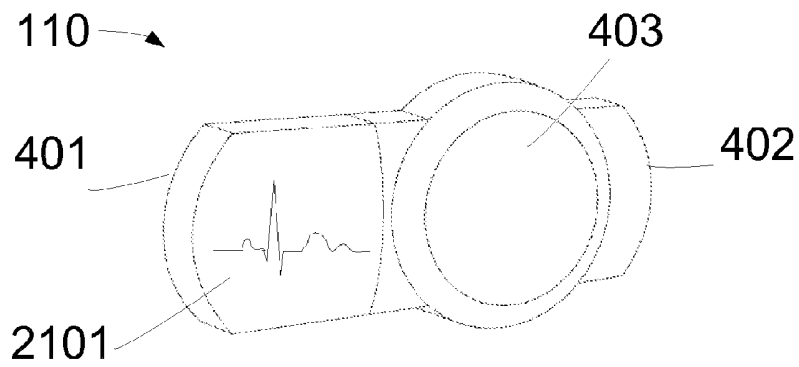

Figure 21

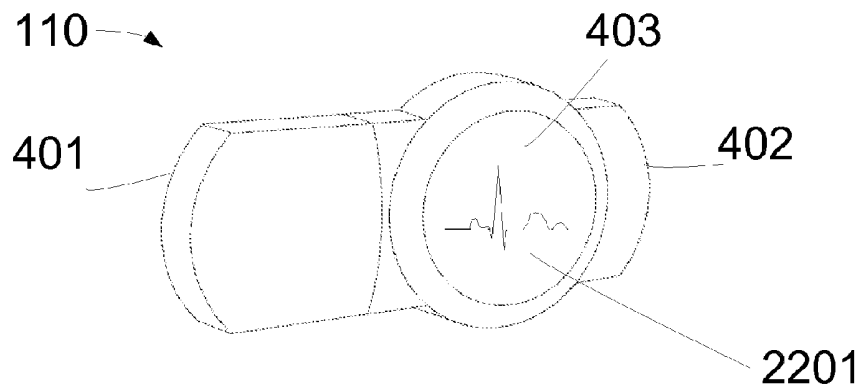

Figure 22

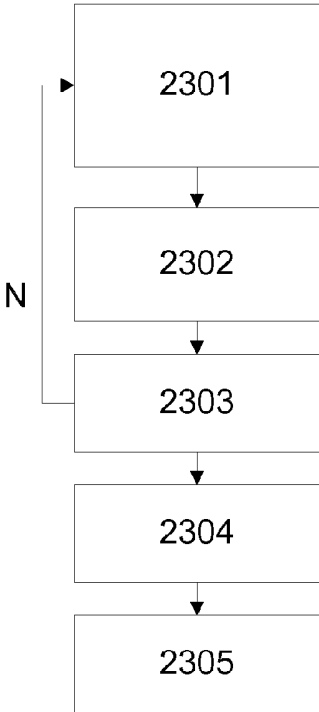

Figure 23A

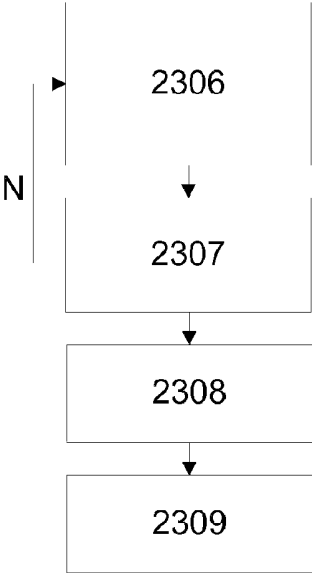

Figure 23B

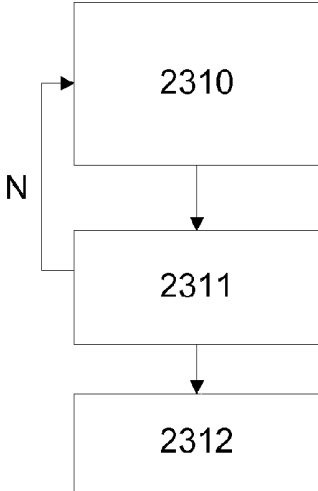

Figure 23C

**SYSTEMS AND METHODS FOR
INTERELECTRODE DISTANCE
OPTIMIZATION IN A RETRACTABLE
MULTI-USE CARDIAC MONITOR**

RELATED APPLICATIONS

[0001] This application is a continuation and claims the benefit under 35 U.S.C. §120 of U.S. patent application Ser. No. 13/111,517 filed on May 19, 2011 and titled Retractable Multi-Use Cardiac Monitor, which in turn, claimed the benefit under 35 U.S.C. §119(e) of U.S. Provisional Patent Application No. 61/347,117, filed on May 21, 2010 and titled Retractable Multi-Use Cardiac Monitor, the entire contents of each of which are incorporated herein by reference to the extent that they do not conflict with the disclosure herein.

FIELD OF THE INVENTION

[0002] The present invention relates generally to the field of cardiac monitoring. Specifically, the present invention is directed towards a retractable multi-use cardiac monitor.

BACKGROUND

[0003] Cardiac monitoring systems are generally comprised of a series of electrodes attached to the chest area of a patient to collect electrocardiogram (ECG) data. The series of electrodes are usually connected to a series of wires. However, the inventor has perceived that the series of electrodes and interconnected wires are not provided in a compact portable form that allows for easy adjustment of the vector length between the electrodes.

[0004] Accordingly, the inventor has perceived that there is a need for a retractable multi-use cardiac monitor that is compact in form and allows for easy adjustment of the vector length between the electrodes of the retractable multi-use cardiac monitor.

[0005] This background information is provided to reveal information believed by the applicant to be of possible relevance to the present invention. No admission is necessarily intended, nor should be construed, that any of the preceding information constitutes prior art against the present invention.

SUMMARY OF THE INVENTION

[0006] With the above in mind, embodiments of the present invention provide a retractable multi-use cardiac monitor that advantageously allows for easy and function-enhancing adjustment of the vector length between the electrodes of the retractable multi-use cardiac monitor.

[0007] According to one embodiment, the retractable multi-use cardiac monitor includes a processor and a memory, a first side comprising a first housing wherein a first sensing connector is on the outside of the first housing, and wherein the first sensing connector is configured to collect electrocardiogram (ECG) data and store ECG data onto the memory. The retractable multi-use cardiac monitor further includes a second side comprising a second housing including a wire retractor and a second sensing connector, wherein the second sensing connector is on the outside of the second housing, and the wire retractor is configured to extend and retract a wire that connects the second and first sides, and wherein the second sensing connector is configured to collect ECG data and store ECG data onto the memory, and a wireless radio configured to transmit a portion of collected ECG data from the memory to a destination.

[0008] According to another embodiment, a method of collecting electrocardiogram (ECG) data with a retractable multi-use cardiac monitor is provided, wherein the retractable multi-use cardiac monitor includes a processor and a memory, a first side that includes a first housing wherein a first sensing connector is on the outside of the first housing, a second side including a second housing and a second sensing connector, wherein the second sensing connector is on the outside of the second housing, and a wireless radio. The method includes collecting ECG data from the first and second sensing connectors of the retractable multi-use cardiac monitor, wherein the first and second sensing connectors are placed against the skin of a chest area of a human patient, recording the collected ECG data onto the memory of the retractable multi-use cardiac monitor, and transmitting a portion of the collected ECG data to a destination.

[0009] According to yet another embodiment, a method of determining an optimum electrode vector length between a first sensing connector of a first side of a retractable multi-use cardiac monitor and a second sensing connector of a second side of the retractable multi-use cardiac monitor is provided. The method includes (A) receiving from the retractable multi-use cardiac monitor at a smart phone data representing a distance between the first sensing connector of the retractable multi-use cardiac data monitor and the second sensing connector of the retractable multi-use cardiac data monitor, wherein the smart phone includes a processor, (B) receiving electrocardiogram (ECG) data collected by the retractable multi-use cardiac data monitor through the first and second sensing connectors, (C) recording the ECG data collected in step B and the data representing the distance between the first and second sensing connectors received in step A, and (D) iteratively repeating steps A-C a number of times. The method further includes (E) calculating, by the processor of the smart phone, an optimum electrode vector length between the first sensing connector of the first side of the retractable multi-use cardiac monitor and the second sensing connector of the second side of the retractable multi-use cardiac monitor based on the ECG data collected in step B and the data representing the distance between the first and second sensing connectors received in step A, and (F) generating a notification of that the optimum electrode vector length has been found.

[0010] According to yet another embodiment a method of determining an optimum electrode vector length between a first sensing connector of a first side of a retractable multi-use cardiac monitor and a second sensing connector of a second side of the retractable multi-use cardiac monitor is provided. The method includes (A) determining a distance between the first sensing connector of the retractable multi-use cardiac data monitor and the second sensing connector of the retractable multi-use cardiac data monitor, and recording data representing the distance, (B) collecting electrocardiogram (ECG) data through the first and second sensing connectors and recording the collected ECG data, and (C) iteratively repeating A-B a number of times. The method further includes (E) calculating, by a processor of the retractable multi-use cardiac monitor, an optimum electrode vector length between the first sensing connector of the first side of the retractable multi-use cardiac monitor and the second sensing connector of the second side of the retractable multi-use cardiac monitor based on the ECG data collected in step B and the data representing the distance between the first and sec-

ond sensing connectors recorded in step A, and (F) generating a notification of that the optimum electrode vector length has been found.

BRIEF DESCRIPTION OF THE DRAWINGS

[0011] FIG. 1 is an illustration of a cardiac monitor system, according to one embodiment.

[0012] FIG. 2A is an illustration of a cardiac monitor system, according to one embodiment.

[0013] FIG. 2B is an illustration of a cardiac monitor system, according to one embodiment.

[0014] FIG. 2C is an illustration of a cardiac monitor system, according to one embodiment.

[0015] FIG. 3A is an illustration of a cardiac monitor system, according to one embodiment.

[0016] FIG. 3B is an illustration of a cardiac monitor system, according to one embodiment.

[0017] FIG. 3C is an illustration of a cardiac monitor system, according to one embodiment.

[0018] FIG. 4 is a top-down view of a retractable multi-use cardiac monitor, according to one embodiment.

[0019] FIG. 5 is a top-down view of a retractable multi-use cardiac monitor, according to one embodiment.

[0020] FIG. 6 is a top-down view of a retractable multi-use cardiac monitor, according to one embodiment.

[0021] FIG. 7 is an illustration of a wearable electrode, according to one embodiment.

[0022] FIG. 8 is a top-down view of a retractable multi-use cardiac monitor with wearable electrodes attached, according to one embodiment.

[0023] FIG. 9 is a bottom-up view of a retractable multi-use cardiac monitor with wearable electrodes attached, according to one embodiment.

[0024] FIG. 10 is a top-down view of a retractable multi-use cardiac monitor with wearable electrodes attached, according to one embodiment.

[0025] FIG. 11 is a side-view of a retractable multi-use cardiac monitor, according to one embodiment.

[0026] FIG. 12 is a side-view of a retractable multi-use cardiac monitor, according to one embodiment.

[0027] FIG. 13 is a side-view of a retractable multi-use cardiac monitor with wearable electrodes attached, according to one embodiment.

[0028] FIG. 14A is an illustration of a retractable multi-use cardiac monitor attached to a cardiac monitoring patient, according to one embodiment.

[0029] FIG. 14B is a flowchart illustrating the determination of an optimum electrode vector length, according to one embodiment.

[0030] FIG. 14C is a flowchart illustrating the determination of an optimum electrode vector length, according to one embodiment.

[0031] FIG. 14D is a flowchart illustrating the determination of an optimum electrode vector length, according to one embodiment.

[0032] FIG. 14E is a flowchart illustrating the collection and transmission of data, according to one embodiment.

[0033] FIG. 15 is an illustration of a finger electrode configuration of a retractable multi-use cardiac monitor, according to one embodiment.

[0034] FIG. 16 is an illustration of a finger electrode configuration of a retractable multi-use cardiac monitor, according to one embodiment.

[0035] FIG. 17 is a top-down view of a retractable multi-use cardiac monitor that includes multiple additional wires, according to one embodiment.

[0036] FIG. 18 is a side-view of a retractable multi-use cardiac monitor, according to one embodiment.

[0037] FIG. 19 is a side-view of a retractable multi-use cardiac monitor, according to one embodiment.

[0038] FIG. 20 is a side-view of a retractable multi-use cardiac monitor, according to one embodiment.

[0039] FIG. 21 is a top-down view of a retractable multi-use cardiac monitor, according to one embodiment.

[0040] FIG. 22 is a top-down view of a retractable multi-use cardiac monitor, according to one embodiment.

[0041] FIG. 23A is a flowchart illustrating the determination of a set of optimum electrode vector lengths, according to one embodiment.

[0042] FIG. 23B is a flowchart illustrating the determination of a set of optimum electrode vector lengths, according to one embodiment.

[0043] FIG. 23C is a flowchart illustrating the determination of a set of optimum electrode vector lengths, according to one embodiment.

DETAILED DESCRIPTION OF THE INVENTION

[0044] The present invention will now be described more fully hereinafter with reference to the accompanying drawings, in which preferred embodiments of the invention are shown. This invention may, however, be embodied in many different forms and should not be construed as limited to the embodiments set forth herein. Rather, these embodiments are provided so that this disclosure will be thorough and complete, and will fully convey the scope of the invention to those skilled in the art. Those of ordinary skill in the art realize that the following descriptions of the embodiments of the present invention are illustrative and are not intended to be limiting in any way. Other embodiments of the present invention will readily suggest themselves to such skilled persons having the benefit of this disclosure. Like numbers refer to like elements throughout.

[0045] Although the following detailed description contains many specifics for the purposes of illustration, anyone of ordinary skill in the art will appreciate that many variations and alterations to the following details are within the scope of the invention. Accordingly, the following embodiments of the invention are set forth without any loss of generality to, and without imposing limitations upon, the claimed invention.

[0046] In this detailed description of the present invention, a person skilled in the art should note that directional terms, such as "above," "below," "upper," "lower," and other like terms are used for the convenience of the reader in reference to the drawings. Also, a person skilled in the art should notice this description may contain other terminology to convey position, orientation, and direction without departing from the principles of the present invention.

[0047] Furthermore, in this detailed description, a person skilled in the art should note that quantitative qualifying terms such as "generally," "substantially," "mostly," and other terms are used, in general, to mean that the referred to object, characteristic, or quality constitutes a majority of the subject of the reference. The meaning of any of these terms is dependent upon the context within which it is used, and the meaning may be expressly modified.

[0048] Moreover, the use of the terms first, second, etc. do not denote any order or importance, but rather the terms first,

second, etc. are used to distinguish one element from another. Furthermore, the use of the terms a, an, etc. do not denote a limitation of quantity, but rather denote the presence of at least one of the referenced item. With regard to the present disclosure, terms such as “left”, “right”, and “portion” are used to identify parts of the disclosed retractable multi-use cardiac monitor and are not meant to be limiting, nor to mean that such parts of the disclosed retractable multi-use cardiac monitor are in any particular position or orientation relative to the outside environment.

[0049] It is to be understood that both the foregoing brief description of the drawings and the following detailed description are exemplary and explanatory only, and are not restrictive of the invention. These and other features, aspects and advantages of the present invention will become apparent from the following description, and the accompanying exemplary embodiments shown in the drawings, which are briefly described below.

[0050] Applicant hereby incorporates by reference U.S. Patent Publication No. 2008/0097231, published Apr. 28, 2008 and titled Cardiac Event Monitoring System (see also U.S. patent application Ser. No. 11/550,759, filed Oct. 18, 2006). For example, and without limitation, the retractable multi-use cardiac monitor **110** as herein described may be used as a wearable electrode system (**110** of U.S. Patent Publication No. 2008/0097231) within a cardiac event monitoring system (**100** of U.S. Patent Publication No. 2008/0097231).

[0051] Cardiac event monitoring is a procedure that is conducted on patients who report symptoms that may be cardiac in origin, and that occur infrequently, such as, for example, three times or less in one week. Cardiac monitoring is performed by the sensing and storage of electrocardiogram (ECG) data that characterizes activity of a patient's heart by a “cardiac monitor.” In some instances, “event monitoring” is used to detect clinically significant heart related events. Event monitoring may be performed by patient activation, whereby the patient senses a cardiac event and causes data to be recorded. In other embodiments of event monitoring, a cardiac monitor analyzes incoming ECG data, identifies a clinically significant ECG event, and stores data related to the detected ECG event (e.g. an event monitor may identify particular types of Arrhythmias). In some embodiments, the cardiac monitor's ability to analyze incoming ECG data allows the cardiac monitor to detect a cardiac condition where a patient is otherwise asymptomatic.

[0052] Another type of monitoring is “Holter” monitoring. Holter monitoring is directed to constant recording and storage of ECG data from a patient. The quality and amount of ECG data recorded and stored varies based on quality requirements and memory storage limitations. Another cardiac monitoring technology is mobile cardiac telemetry. Mobile cardiac telemetry cardiac monitors may be configured to perform various types of event monitoring as well as constant storage of ECG similar to a holter monitor. In some embodiments, mobile cardiac telemetry monitors operate using auto-push technology that is configured to automatically transmit collected data to a monitoring center. A patient generally carries a cardiac monitor during a testing period, which can last for several days or up to, for example, 30 days.

[0053] An embodiment of the invention text, as shown and described by the various figures and accompanying text, provides a retractable multi-use cardiac monitor.

[0054] FIG. 1 illustrates an example of a cardiac monitor system. Referring to FIG. 1, a cardiac monitor system **100** may include a base unit **105** (the cardiac monitor of the illustrated system of FIG. 1), and a retractable multi-use cardiac monitor **110**. The retractable multi-use cardiac monitor **110** may include a processor and a memory. The processor may be a microcontroller or a microprocessor. The memory may be a RAM, EEPROM, FLASH, or any other suitable volatile or non-volatile storage medium or device. The base unit **105** may include a base connector **120** and a body **107** that may house the electrical components and may include a user interface. The retractable multi-use cardiac monitor **110** may collect ECG data from a patient and may provide that data to the base unit **105** through wireless communication by a wireless radio. In some embodiments, the retractable multi-use cardiac monitor **110** may store the collected ECG data in a memory of the retractable multi-use cardiac monitor **110** prior to transmission. The wireless communication between the retractable multi-use cardiac monitor **110** and the base unit **105** may be accomplished using any one of a variety of different wireless technologies including, for example, and without limitation, 900 Mhz radio, Bluetooth, IEEE 802.11 (Wi-Fi), WLAN, Personal Area Network, TransferJet, Ultra-wideband (UWB), IrDA, RFID, Wireless USB, Near Field Communication, or ZigBee. In an alternative embodiment, the communication between the retractable multi-use cardiac monitor **110** and the base unit **105** may be wired.

[0055] Further, in some embodiments the retractable multi-use cardiac monitor **110** may be powered by a battery, while in other embodiments the retractable multi-use cardiac monitor **110** may be powered by a wired connection to base unit **105**. In yet further embodiments, the retractable multi-use cardiac monitor **110** may collect other biological data, such as temperature, and may provide such data to base unit **105** by a wireless radio or through a wired connection, as discussed above, which may be further transmitted as discussed in reference to FIG. 2C or viewed by a health care professional as discussed below.

[0056] Referring now to FIGS. 1, 2A and 2B, the base unit **105** may be pager-sized, and may be either handheld or patient-worn. The base unit **105** may include the body **107** that may house components that may control operation of the cardiac monitor system **100**. Thus, the base unit **105** may include a controller **150** within the body **107**, and various input and output devices that may be coupled to the controller **150** through the body **107**. The controller **150** may receive power from a power source **155** that may be provided by batteries that may be placed within a compartment **200** on a side of the body **107**. The body **107** and the battery compartment **200** may be made of a suitable non-conductive lightweight material, such as a rigid plastic. The power source **155** may be turned off and on by a switch **205** (FIGS. 1 and 2B) accessible on the compartment **200** and connected to the power source **155** and the controller **150**.

[0057] The controller **150** may include a processor **151**, memory **152**, a clock **153**, and a counter **154** to process signals from the retractable multi-use cardiac monitor **110**, receive input from a patient or a service technician using the system **100**, and transmit recorded data to a monitoring center, as provided by a health professional, a clinic, or a hospital. In an alternative embodiment, input received from the retractable multi-use cardiac monitor **110** may be retained by the base unit **105** and displayed on the base unit **105** at a later time. For example, the input received from the retractable

multi-use cardiac monitor **110** may later be shown to a doctor or other health professional during a patient visit. In some embodiments, the base unit **105** both may transmit collected data to a monitoring center and may retain collected data for later display or use.

[0058] The input devices on the base unit **105** may include a symptom record button **160**, a yes/transmit button **165**, and a no button **170**. The yes/transmit button **165** may be used in one of two ways: it may be used as a response button to answer “yes” when queried by the controller **150**, or it may be used to indicate to the controller **150** to transmit the ECG. The no button **170** may be used in one of two ways: it may be used as a response button to answer “no” when queried by the controller **150**, or it may be used to indicate to the controller **150** to cancel a transmission of an ECG.

[0059] The output devices on the base unit **105** may include a display **175** such as a liquid crystal display (LCD) that may provide an interface with the patient and/or a technician, and a speaker **180** for transmitting data regarding the recording. For example, the display **175** may be used to show data collected from the retractable multi-use cardiac monitor **110** to a health care professional during a patient visit.

[0060] The system **100** may be worn for days or weeks, as it may be intended for use by patients who are experiencing symptoms that are transient and infrequent in nature. The base unit **105** may be worn outside the patient’s clothing if there is any chance that moisture (for example, sweat) might come in contact with the base unit **105**. The base unit **105** may be worn under outer wear, such as raincoats or jackets, for protection during wet or cold conditions. In one embodiment, the base unit **105** may operate as a Holter monitor, or may operate as an event monitor. In an alternative embodiment, the base unit **105** may operate as a mobile cardiac telemetry monitor. In some embodiments, the base unit **105** may operate as both a Holter monitor and an event monitor.

[0061] FIG. 2C illustrates various communication schemes for the base unit **105**. In some embodiments, the base unit **105** may transmit data to a monitoring center, as provided by a health professional, a clinic, or a hospital by communicating with a cellular tower **201** of a cellular network. In an alternative embodiment, the base unit **105** may transmit data to a monitoring center by communicating with a computer **202** that may include an application which stores and forwards the data to the monitoring center through the Internet (e.g. by email). The application on computer **202** may also be configured to allow a user of the base unit **105** to print reports of the data collected by the base unit **105**. Communication with the computer **202** may be wired or wireless. For example, the base unit **105** may plug into the computer **202** using a USB or firewire cable. In an alternative embodiment, the base unit **105** may communicate with the computer **202** through a variety of different wireless technologies including but not limited to 900 Mhz radio, Bluetooth, IEEE 802.11 (Wi-Fi), WLAN, Personal Area Network, TransferJet, Ultra-wideband (UWB), IrDA, RFID, Wireless USB, Near Field Communication, or ZigBee. In another embodiment, the base unit **105** may simply communicate with a wireless router **203** which may then communicate to the monitoring center through the Internet. The wireless router **203** may support any number of wireless technologies including, for example, and without limitation, IEEE 802.11 (Wi-Fi). In a related embodiment, the base unit **105** may be configured to detect the presence of the wireless router **203**, and when the presence of the wireless router **203** is detected, the base unit **105** oppor-

tunistically may transmit collected data to the wireless router **203** which then may transmit the data to the monitoring center. In yet another embodiment, the base unit **105** may be configured to transmit data to a monitoring center over a telephone connection by audio modulation through the speaker **180**. In yet further embodiments, the base unit **105** may transmit collected data to the monitoring center through any number of intermediaries and through any number of communication technologies.

[0062] FIG. 3A illustrates an alternative embodiment where a cardiac monitoring system **100** may be comprised of a smart phone **301** (the cardiac monitor of the illustrated system of FIG. 3A) as well as a retractable multi-use cardiac monitor **110**. The smart phone **301** may include a processor and a memory (not illustrated as they are within the smart phone **301**). The smart phone **301** also may include a display screen **305**. In the disclosed embodiment, the retractable multi-use cardiac monitor **110** may transmit collected ECG data to the smart phone **301**. In some embodiments, the retractable multi-use cardiac monitor **110** may store the collected ECG data in a memory of the retractable multi-use cardiac monitor **110** prior to transmission. The smart phone **301** may operate as a Holter monitor, or may operate as an event monitor. In an alternative embodiment, the smart phone **301** may operate as a mobile cardiac telemetry monitor. In some embodiments, the smart phone **301** may operate as both a Holter monitor and an event monitor. In one embodiment, the retractable multi-use cardiac monitor **110** may wirelessly transmit collected ECG data to the smart phone **301** by a wireless radio. The wireless communication between the retractable multi-use cardiac monitor **110** and the smart phone **301** may be accomplished using any one of a variety of different wireless technologies including, for example, and without limitation, 900 Mhz radio, Bluetooth, IEEE 802.11 (Wi-Fi), WLAN, Personal Area Network, TransferJet, Ultra-wideband (UWB), IrDA, RFID, Wireless USB, Near Field Communication, or ZigBee. In an alternative embodiment, the communication between the retractable multi-use cardiac monitor **110** and the smart phone **301** may be wired. Further, in some embodiments, the retractable multi-use cardiac monitor **110** may be powered by a battery, while in other embodiments the retractable multi-use cardiac monitor **110** may be powered by a wired connection to smart phone **301**. As noted above, the retractable multi-use cardiac monitor **110** may include a processor and a memory. The processor may be a microcontroller or a microprocessor. The memory may be a RAM, EEPROM, FLASH, or any other suitable volatile or non-volatile storage medium or device. In yet further embodiments, the retractable multi-use cardiac monitor **110** may collect other biological data, such as temperature, and may provide such data to the smart phone **301** by a wireless radio or through a wired connection as discussed above, which may be further transmitted as discussed in reference to FIG. 3B or viewed by a health care professional as discussed below.

[0063] The smart phone **301** may be configured to transmit data to a monitoring center, as provided by a health professional, a clinic, or a hospital. In an alternative embodiment, input received from the retractable multi-use cardiac monitor **110** may be retained by the smart phone **301** and may be displayed on the smart phone **301** at a later time or may be used at a later time. For example, the input received from the retractable multi-use cardiac monitor **110** may later be shown to a doctor or other health professional during a patient visit on the display screen **305** of the smart phone **301**. In some

embodiments, the smart phone 301 both may transmit collected data to a monitoring center and may retain collected data for later display or use.

[0064] FIG. 3B illustrates various communication schemes for the smart phone 301. In some embodiments, the smart phone 301 may transmit data collected from the retractable multi-use cardiac monitor 110 to a monitoring center, as provided by a health professional, a clinic, or a hospital by communicating with a cellular tower 302 of a cellular network. In an alternative embodiment, the smart phone 301 may transmit data to a monitoring center by communicating with a computer 303 that may include an application which stores and forwards the data to the monitoring center through the Internet (e.g. by email). The application on computer 303 may also be configured to allow a user of the smart phone 301 to print reports of the ECG data collected by the smart phone 301. Communication with the computer 302 may be wired or wireless. For example, and without limitation, the smart phone 301 may plug into the computer using a USB or firewire cable. In an alternative embodiment, the smart phone 301 may communicate with the computer 303 through a variety of different wireless technologies including, for example, and without limitation, 900 Mhz radio, Bluetooth, IEEE 802.11 (Wi-Fi), WLAN, Personal Area Network, TransferJet, Ultra-wideband (UWB), IrDA, RFID, Wireless USB, Near Field Communication, or ZigBee. In another embodiment, the smart phone 301 simply may transmit collected data to a wireless router 304 which then may transmit the data to the monitoring center through the Internet. The wireless router 304 may support any number of wireless technologies including, for example, and without limitation, IEEE 802.11 (Wi-Fi). In a related embodiment, the smart phone 301 may be configured to detect the presence of the wireless router 304, and when the presence of the wireless router 304 is detected, the smart phone 301 opportunistically may transmit collected data to the wireless router 304 which then may transmit the data to the monitoring center. In yet another embodiment, the smart phone 301 may be configured to transmit data to a monitoring center over a telephone connection by audio modulation. In yet further embodiments, the smart phone 301 may transmit collected data to the monitoring center through any number of intermediaries and through any number of communication technologies.

[0065] Regarding the transmission of data, the retractable multi-use cardiac monitor 110 may store collected data on an on-board memory and may “push” the data to a cardiac monitor (e.g. base unit 105 of FIG. 1 or smart phone 301 of FIG. 3A). Alternatively, the retractable multi-use cardiac monitor 110 may store collected data on an on-board memory and may be designed to await a request from a cardiac monitor (e.g. base unit 105 of FIG. 1 or smart phone 301 of FIG. 3A) to “pull” data from the retractable multi-use cardiac monitor 110. Further, the retractable multi-use cardiac monitor 110 may be configured to stream data as it is collected directly to a cardiac monitor (e.g. base unit 105 of FIG. 1 or smart phone 301 of FIG. 3A).

[0066] FIG. 3C illustrates an embodiment where the multi-use cardiac monitor 110 itself may comprise the entire cardiac monitoring system 100. The multi-use cardiac monitor 110 may operate as a Holter monitor, or may operate as an event monitor. In an alternative embodiment, the multi-use cardiac monitor 110 may operate as a mobile cardiac telemetry monitor. In some embodiments, the multi-use cardiac monitor 110 may operate as both a Holter monitor and an

event monitor. In some embodiments, the multi-use cardiac monitor 110 may be configured to transmit collected ECG data to a monitoring center, as provided by a health professional, a clinic, or a hospital. In some embodiments, the retractable multi-use cardiac monitor 110 may store the collected ECG data in a memory of the retractable multi-use cardiac monitor 110 prior to transmission. In an alternative embodiment, the retractable multi-use cardiac monitor 110 may include a display screen and the retractable multi-use cardiac monitor 110 may retain any collected ECG data and may display the collected ECG data at a later time. For example, and without limitation, the collected ECG data may later be shown to a doctor or other health professional during a patient visit on a display screen (e.g., 2101 or FIG. 21 or 2201 of FIG. 22) of the retractable multi-use cardiac monitor 110. In some embodiments, the retractable multi-use cardiac monitor 110 both may transmit collected ECG data to a monitoring center and may retain collected ECG data for later display. As noted above, the retractable multi-use cardiac monitor 110 may include a processor and a memory. The processor may be a micro controller or a microprocessor. The memory may be a RAM, EEPROM, FLASH, or any other suitable volatile or non-volatile storage medium or device. In yet further embodiments, the retractable multi-use cardiac monitor 110 may collect other biological data, such as temperature, and may transmit such data as discussed above and below, and may retain the data for later display or use.

[0067] FIG. 3C also illustrates various communication schemes for the retractable multi-use cardiac monitor 110 where it comprises the entire cardiac monitor system 100. In some embodiments, the retractable multi-use cardiac monitor 110 may transmit collected data to a monitoring center, as provided by a health professional, a clinic, or a hospital by communicating with a cellular tower 302 of a cellular network by a wireless radio. In an alternative embodiment, the retractable multi-use cardiac monitor 110 may transmit data to a monitoring center by communicating with a computer 303 that may include an application which stores and forwards the data to the monitoring center through the Internet (e.g. by email). The application on computer 303 may also be configured to allow a user of the retractable multi-use cardiac monitor 110 to print reports of the data collected by the retractable multi-use cardiac monitor 110. Communication with the computer 302 may be wired or wireless by a wireless radio. For example, and without limitation, the retractable multi-use cardiac monitor 110 may plug into the computer using a USB or firewire cable. In an alternative embodiment, the retractable multi-use cardiac monitor 110 may communicate with the computer 303 through a variety of different wireless technologies including, for example, and without limitation, 900 Mhz radio, Bluetooth, IEEE 802.11 (Wi-Fi), WLAN, Personal Area Network, TransferJet, Ultra-wideband (UWB), IrDA, RFID, Wireless USB, Near Field Communication, or ZigBee. In another embodiment, the retractable multi-use cardiac monitor 110 by a wireless radio simply may transmit collected data to a wireless router 304 which then may transmit the data to the monitoring center through the Internet. The wireless router 304 may support any number of wireless technologies including, for example, and without limitation, IEEE 802.11 (Wi-Fi). In a related embodiment, the retractable multi-use cardiac monitor 110 may be configured to detect the presence of the wireless router 304, and when the presence of the wireless router 304 is detected, the retractable multi-use cardiac monitor 110 opportunistically may trans-

mit collected data by a wireless radio to the wireless router 304 which then may transmit the data to the monitoring center. In yet another embodiment, the retractable multi-use cardiac monitor 110 may be configured to transmit data to a monitoring center over a telephone connection by audio modulation. In yet further embodiments, the retractable multi-use cardiac monitor 110 may transmit collected data to the monitoring center through any number of intermediaries and through any number of communication technologies.

[0068] FIG. 4 is a top-down view of a retractable multi-use cardiac monitor 110, according to one embodiment. The retractable multi-use cardiac monitor 110 may include left 401 and right sides 402 each comprised of a left and right side housing (also referenced as 401 and 402 respectively). The retractable multi-use cardiac monitor 110 may be comprised of anyone of a number of different materials including, for example, and without limitation, plastic and metal. The illustrated embodiment of FIG. 1 includes a symptom button 403 on the right 402 side of the retractable multi-use cardiac monitor 110. In one embodiment, the symptom button 403 may be used by the patient to “wake up” the cardiac monitor with which the retractable multi-use cardiac monitor 110 is associated, such that the cardiac monitor may begin recording data as either a Holter or event or mobile cardiac telemetry (MCT) monitor depending on the cardiac monitor’s configuration. In an alternative embodiment, the symptom button 403 may be used to indicate that a cardiac “event” has occurred, and the retractable multi-use cardiac monitor 110 may begin to record data relative to the “event.” In various alternative embodiments, the symptom button 403 may be used as an input to the retractable multi-use cardiac monitor 110, a cardiac monitor with which the retractable multi-use cardiac monitor 110 is associated, or any other portion of a system with which the retractable multi-use cardiac monitor 110 is associated. In an alternative embodiment, the symptom button 403 may be disposed on the left 401 side of the retractable multi-use cardiac monitor 110. The embodiment of FIG. 4 also illustrates each of a processor 404, a memory 405, and a wireless radio 406. Each of processor 404, memory 405, and wireless radio 406 are illustrated with dashed lines because they lie below the outer surface of the right side housing 402 and within the right side housing 402. One of skill in the art would appreciate that each of the processor 404, memory 405, and wireless radio 406 may be placed in various locations within the retractable multi-use cardiac monitor 110. For example, and without limitation, processor 404 could be included in the left side housing 401. As noted above, each of the processor 404, memory 405, and wireless radio 406 may be of various types in various embodiments.

[0069] FIG. 5 is also a top-down view of a retractable multi-use cardiac monitor 110, according to one embodiment of the present invention. The embodiment of FIG. 5 illustrates a retractable wire 501 that may connect the left 401 and right 402 sides of the retractable multi-use cardiac monitor 110. The wire 501 may be fiber-optic or electrical. Further, the wire 501 may be shielded or non-shielded. In one embodiment, the wire 501 may retract into the right side 402. In another embodiment, the wire 501 may retract into the left side 401. In both embodiments, the left 401 and right 402 sides of retractable multi-use cardiac monitor 110 may be extended away from and retracted toward one another. The retractable nature of the retractable multi-use cardiac monitor 110 may advantageously allow for easy and convenient storage of the wire 501.

[0070] FIG. 6 is yet another illustration of an embodiment of a retractable multi-use cardiac monitor 110. The illustrated embodiment includes left 401 and right 402 sides, as well as a retractable wire 501. The illustrated embodiment also includes a symptom button 403 on the right side 402 of the retractable multi-use cardiac monitor 110.

[0071] FIG. 7 is a top-down view of a wearable electrode 700, according to one embodiment of the present invention. The wearable electrode 700 may be comprised of an electrode contact 702 that may be configured to contact skin. The wearable electrode 700 may detect electrical signals from a patient’s heart through the electrode contact 702. The wearable electrode 700 also may include a top surface 703, as well as a bottom surface 701 that may include adhesive to facilitate connection of the wearable electrode 700 to skin. The wearable electrode 700 also may include a connector 704 to allow the wearable electrode to be connected to a device. The connector 704 is illustrated as a metal post. In some embodiments, the bottom surface 701 may also be coated with a gel that may improve electrical conduction between the patient’s skin and the electrode contact 702.

[0072] FIG. 8 is a top-down view of a retractable multi-use cardiac monitor 110 with wearable electrodes (left 801 and right 802) attached, according to one embodiment of the present invention. FIG. 9 is a bottom-up view of a retractable multi-use cardiac monitor 110 with wearable electrodes (left 801 and right 802) attached, according to one embodiment. The left wearable electrode 801 may include a left electrode contact 901 and the right wearable electrode 802 may include a right electrode contact 902. The left 801 and right 802 wearable electrodes may connect to the left 401 and right 402 sides of the retractable multi-use cardiac monitor 110 by connection to the left 903 and right 904 sensing connectors. By way of example, FIG. 7 illustrates a connector 704 for a wearable electrode 700. In one embodiment, the sensing connectors (903 and 904) may be configured to accept the connector post 704 for connection to a wearable electrode.

[0073] As discussed above with respect to FIG. 7, these wearable electrodes may be configured to contact the skin of a patient to detect electrical signals of the patient’s heart through the electrode contacts. In one embodiment, the wearable electrodes (left 801 and right 802) and consequently the electrode contacts (left 901 and right 902) may be designed to be temporarily placed against the patient’s skin by the patient to detect a small amount of ECG data. For example, a patient may not be feeling well, and may desire to make a short recording of ECG data by holding the wearable electrodes (left 801 and right 802) of the retractable multi-use cardiac monitor 110 against his skin for short period. In another embodiment, the wearable electrodes (left 801 and right 802) and consequently the electrode contacts (left 901 and right 902) may be designed to be attached for an extended period of time. As discussed above, in some embodiments an adhesive may be provided for wearable electrodes, which may facilitate the attachment of the left 801 and right 802 wearable electrodes for an extended period of time. The left 401 and right 402 sides of the retractable multi-use cardiac monitor 110 are shown as dashed lines in this bottom-up view because they are disposed behind the left 801 and right 802 wearable electrodes. Similarly, the left 903 and right 904 sensing connectors are shown as dashed lines in this bottom-up view because they are disposed behind the left 801 and right 802 wearable electrodes. The left 903 and right 904 sensing connectors, or the combination of the left 801 and right 802

wearable electrodes with the left **903** and right **904** sensing connectors, collect ECG and other biological data.

[0074] FIG. **10** is a top-down view of a retractable multi-use cardiac monitor with wearable electrodes (left **801** and right **802**) attached. The FIG. **10** embodiment illustrates that the wire **501** may be flexible, and may move flexibly in any direction. FIG. **10** illustrates the left **901** and right **902** electrode contacts as dashed lines in this top-down view because they are disposed behind the left **401** and right **402** sides, as well as the left **801** and right **802** wearable electrodes, respectively.

[0075] FIG. **11** is a side-view of a retractable multi-use cardiac monitor **110**, according to one embodiment of the present invention. FIG. **11** illustrates left **903** and right **904** sensing connectors which protrude away from the left **401** and right **402** sides of the retractable multi-use cardiac monitor **110**.

[0076] FIG. **12** is a side-view of a retractable multi-use cardiac monitor **110**, according to one embodiment of the present invention. FIG. **12** illustrates the extractable wire **501** that connects the left **401** and right **402** sides of the retractable multi-use cardiac monitor **110**. FIG. **13** is a side-view of a retractable multi-use cardiac monitor **110** with wearable electrodes (left **801** and right **802**) attached, according to one embodiment. FIG. **13** similarly illustrates the extractable wire **501** that connects the left **401** and right **402** sides of the retractable multi-use cardiac monitor **110**. FIG. **13** also illustrates an embodiment in which the sensing connectors **903** and **904** are configured to accept a connector post **704** for wearable electrodes **801** and **802**.

[0077] FIG. **14A** is an illustration of a retractable multi-use cardiac monitor **110** attached to a cardiac monitoring patient **1401**, according to one embodiment of the present invention. The multi-use cardiac monitor **110** may be configured to collect ECG signals through the left **801** and right **802** wearable electrodes that are connected to the patient's **1401** skin. FIG. **14A** illustrates a distance **1402** between the left **401** and right **402** sides of the retractable multi-use cardiac monitor **110**. As discussed above with respect to FIG. **5**, the retractable multi-use cardiac monitor **110** may be configured to allow the left **401** and right **402** sides to be extended away from and retracted toward one another. As discussed above with respect to FIG. **5**, the retractable nature of the wire **501** also may advantageously allow for easy storage of the wire **501**.

[0078] Furthermore, the retractable wire **501** may advantageously allow the distance **1402** between the left **401** and right **402** sides of the retractable multi-use cardiac monitor **110** to be variable. The variable nature of the distance **1402** between the left **401** and right **402** sides may allow a user of the retractable multi-use cardiac monitor **110** to adjust the distance between the left **801** and right **802** wearable contact electrodes that are connected to the patient's **1401** skin and are used to collect ECG signals. Similarly, the variable nature of the distance **1402** may allow a user to adjust the vector length between the corresponding left **903** and right **904** sensing connectors to which the left **801** and right **802** wearable contact electrodes are attached. The distance **1402** may be adjusted by the patient **1401** to achieve an optimum electrode vector length between the left **903** and right **904** sensing connectors for ECG signal collection. In some embodiments, the retractable multi-use cardiac monitor **110** alone or in combination with another cardiac monitor may be configured to assist the patient **1401** with the determination of an optimum electrode vector length.

[0079] Interelectrode distance (vector length) significantly affects the strength and fidelity of detected ECG signals. Various studies have been conducted that analyze the effect of inter electrode distance (vector length) on collected ECG signals. See M. Puurtinen, et al., *Estimation of ECG Signal of closely separated bipolar electrodes using thorax models*, Proceedings of the 26th Annual International Conference of the IEEE EMBS pp. 801-804, San Francisco, Calif., USA, Sep. 1-5, 2004, which is herein incorporated by reference in its entirety.

[0080] FIG. **14B** is a flowchart illustrating the determination of an optimum electrode vector length, according to one embodiment of the present invention. The FIG. **14B** flowchart illustrates the steps of optimum electrode vector length determination from the perspective of a cardiac monitor (e.g. base unit **105** of FIG. **1** or smart phone of FIG. **3A**), in an embodiment where a retractable multi-use cardiac monitor **110** may be used with another cardiac monitor to determine the optimum electrode vector length between the left **903** and right **904** sensing connectors. In step **1402**, data may be received by the cardiac monitor (e.g. base unit **105** of FIG. **1** or smart phone of FIG. **3A**) from the retractable multi-use cardiac monitor **110** representing a distance between the left **401** and right **402** sides of the retractable multi-use cardiac monitor **110** (and consequently left **903** and right **904** sensing connectors). In step **1403**, ECG data collected by the retractable multi-use cardiac monitor **110** at the current distance between the left **401** and right **402** sides may be received by the cardiac monitor (e.g. base unit **105** of FIG. **1** or smart phone of FIG. **3A**). In step **1404**, the received ECG collected data and the data representing the distance between the left **401** and right **402** sides may be recorded by the cardiac monitor (e.g. base unit **105** of FIG. **1** or smart phone of FIG. **3A**). The received ECG collected data and the data representing the distance between the left **401** and right **402** may be recorded in a memory. Steps **1402** through **1404** may be repeated a number of times **N** with various distances between the left **401** and right **402** sides of the retractable multi-use cardiac monitor **110**. In some embodiments, the number of times **N** may be variable. In other embodiments, the number of times **N** may be constant. In yet other embodiments, the number of times **N** may be variable and depends on intermediate calculations performed from the collected ECG data and distance values. In step **1405**, an optimum electrode vector length between the left **903** and right **904** sensing connectors may be calculated based on the ECG and distance data recorded in step **1404** by the processor of the cardiac monitor (e.g. by the processor of base unit **105** of FIG. **1** or the processor of smart phone **301** of FIG. **3A**). In step **1406**, a notification may be generated indicating the optimum electrode vector length has been found. The notification may be generated by the cardiac monitor (e.g. base unit **105** of FIG. **1** or smart phone of FIG. **3A**) or the retractable multi-use cardiac monitor **110**. In some embodiments, the notification may be an audible noise. In other embodiments, the notification may be visual such as by a light or a display on a visual display (e.g. **2101** of FIG. **21** or **2201** of FIG. **22**) of the retractable multi-use cardiac monitor **110**, or by a light or a visual display on the display of a cardiac monitor (e.g. on a display **175** of base unit **105** of FIG. **1** or a display **305** of smart phone **301** of FIG. **3A**).

[0081] In one embodiment, an optimum electrode vector length may be calculated based on comparison of recorded signal strengths of ECG data at various vector distances collected by Steps **1402** through **1404**. In another embodiment,

an optimum electrode vector length may be calculated based on comparison of recorded signal fidelities of ECG data at various vector distances collected by Steps 1402 through 1404. In another embodiment, an optimum electrode vector length may be calculated based on comparison of both recorded signal strengths as well as recorded signal fidelities of ECG data at various vector distances collected by Steps 1402 through 1404. In yet other embodiments, an optimum electrode vector length may be calculated based on analyzing the ECG data at various vector distances collected by Steps 1402 through 1404 to determine if the collected ECG data represents a high fidelity QRS ECG pattern. In yet other embodiments, other signal quality measures are used to calculate an optimum vector length. The intermediate calculations noted above in reference to FIG. 14B may be any of these operations.

[0082] FIG. 14C is a flowchart illustrating the determination of an optimum electrode vector length, according to one embodiment of the present invention. The FIG. 14C flowchart illustrates the steps of optimum electrode vector length determination from the perspective of a retractable multi-use cardiac monitor 110 in an embodiment where the retractable multi-use cardiac monitor 110 determines the optimum vector length between the left 903 and right 904 sensing connectors by itself. In step 1407, the retractable multi-use cardiac monitor 110 may determine a distance between the left 401 and right 402 sides (and consequently left 903 and right 904 sensing connectors) of the retractable multi-use cardiac monitor 110 and the retractable multi-use cardiac monitor 110 may record the distance. In step 1408, the retractable multi-use cardiac monitor 110 may collect and may record ECG data. The ECG data and distance between the left 401 and right 402 sides may be recorded in a memory of the retractable multi-use cardiac monitor 110. Steps 1407 and 1408 may be repeated a number of times N with various distances between the left 401 and right 402 sides. In some embodiments, the number of times N may be variable. In other embodiments, the number of times N may be constant. In yet other embodiments, the number of times N may be variable and may depend on intermediate calculations performed from the collected ECG data and distance between the left 401 and right 402 sides. In step 1409, an optimum electrode vector length between the left 903 and right 904 sensing connectors may be calculated based on the ECG data at various vector distances recorded in steps 1407 and 1408 by a processor of the retractable multi-use cardiac monitor 110. In step 1410, the retractable multi-use cardiac monitor 110 may generate a notification indicating the optimum electrode vector length has been found. In some embodiments, the notification may be an audible noise. In other embodiments, the notification may be visual such as by a light or a display on a display screen (e.g. 2101 of FIG. 21 or 2201 of FIG. 22) of the retractable multi-use cardiac monitor 110.

[0083] In one embodiment, an optimum electrode vector length may be calculated based on comparison of recorded signal strengths of ECG data at various vector distances collected by Steps 1407 and 1408. In another embodiment, an optimum electrode vector length may be calculated based on comparison of recorded signal fidelities of ECG data at various vector distances collected by Steps 1407 and 1408. In yet other embodiments, an optimum electrode vector length may be calculated based on comparison of both recorded signal strengths as well as recorded signal fidelities of ECG data at various vector distances collected by Steps 1407 and

1408. In yet other embodiments, an optimum electrode vector length may be calculated based on analyzing the ECG data at various vector distances collected by Steps 1407 and 1408 to determine if the collected ECG data represents a high fidelity QRS ECG pattern. In yet other embodiments, other signal quality measures may be used to calculate an optimum vector length. The intermediate calculations noted above in reference to FIG. 14C may be any of these operations.

[0084] FIG. 14D is a flowchart illustrating the determination of an optimum electrode vector length, according to one embodiment of the present invention. The FIG. 14D flowchart illustrates the steps of optimum electrode vector length determination from the perspective of a patient or a healthcare professional. In FIG. 14D, the retractable multi-use cardiac monitor 110 alone or in combination with another cardiac monitor may be configured to assist the patient or healthcare professional with the determination of an optimum electrode vector length as explained in FIGS. 14B and 14C above. In step 1411, the patient or healthcare professional may adjust a distance between the left 401 and right 402 sides of the retractable multi-use cardiac monitor 110. In step 1412, the patient or healthcare professional may hold the retractable multi-use cardiac monitor 110 against a portion of a patient body to record data. Steps 1411 and 1412 may be repeated a number of times N with various distances between the left 401 and right 402 sides. In some embodiments, the number of times N may be variable. In other embodiments, the number of times N may be constant. In yet other embodiments, the number of times N may be variable and may depend on intermediate calculations performed from the collected data and distance adjustments. In step 1413, the patient or healthcare professional may receive a notification of the optimum electrode vector length from either a cardiac monitor (e.g. base unit 105 of FIG. 1 or smart phone 301 of FIG. 3A) or from the retractable multi-use cardiac monitor 110, as explained above in the discussion of FIGS. 14B and 14C. In an alternative embodiment, the patient or healthcare professional may not receive a notification in step 1413. Rather, the patient or healthcare professional may review the iteratively collected ECG data at various vector distances to determine the optimum vector length. For example, the patient or healthcare professional may review such data on a display screen (e.g. 2101 of FIG. 21 or 2201 of FIG. 22) of the retractable multi-use cardiac monitor 110, or on a display screen of a cardiac monitor (e.g. display 175 of base unit 105 of FIG. 1 or display 305 of smart phone 301 of FIG. 3A).

[0085] FIG. 14E is a flowchart illustrating the collection of and transmission of data, according to one embodiment of the present invention. In step 1414, the retractable multi-use cardiac monitor 110 may collect ECG or other biological data as described above. In some embodiments, ECG or biological data may be collected from more than two electrodes or sensing connectors as described, for example, and without limitation, in reference to FIGS. 17, 19, and 20 below. In step 1415, the collected data may be stored. The collected data may be stored in a memory of the retractable multi-use cardiac monitor 110. The collected data may be then transmitted as described in the various embodiments above to a destination.

[0086] FIG. 15 is an illustration of a finger electrode configuration of the retractable multi-use cardiac monitor 110, according to one embodiment of the present invention. In the illustrated embodiment, a user of the retractable multi-use cardiac monitor 110 may place a left side finger 1501 and a

right side finger 1502 onto the left 903 and right 904 sensing connectors, respectively. In the illustrated embodiment, the left 1501 and right 1502 fingers are from different hands. The retractable multi-use cardiac monitor 110 as illustrated in FIG. 15 may collect ECG data from a patient when that patient applies the left 1501 and right 1502 side fingers onto the left 903 and right 904 sensing connectors, respectively. FIG. 16 is also an illustration of a finger electrode configuration of the retractable multi-use cardiac monitor 110 with the wire 501 retracted. The FIG. 16 embodiment illustrates a left 1501 and right 1502 finger attached to the left 903 and right 904 sensing connectors, respectively. In the illustrated embodiments of FIGS. 15 and 16, the left 903 and right 904 sensing connectors may be contacted to any body part of a patient to collect ECG data. For example, and without limitation, left 903 and right 904 sensing connectors may be contacted to the chest, the legs, ankles, wrists or the arms of a patient. Also for example, and without limitation, the left 903 and right 904 sensing connectors may be designed with different shapes or sizes. In some embodiments, the left 903 and right 904 sensing connectors may be shaped to receive a finger. As an example, a patient may not be feeling well, and may desire to make a short recording of ECG data without attaching wearable electrodes by merely holding the left 903 and right 904 sensing connectors against their chest for a short period. As a further example, a patient may desire to temporarily hold the left 903 and right 904 sensing connectors against his chest by moving the left 401 and right 402 sides of the retractable multi-use cardiac monitor 110 away from one another to create an optimum vector length as illustrated in FIG. 14A.

[0087] FIG. 17 is a top-down view of a retractable multi-use cardiac monitor 110 that may include a second retractable wire 1703, according to another embodiment of the present invention. In the illustrated embodiment, the retractable multi-use cardiac monitor 110 may include a second wire 1703 that may be connected to a third portion 1701 of the retractable multi-use cardiac monitor 110. The third portion 1701 may also be attached to a third 1702 wearable electrode and may be comprised of a third housing (also referenced as 1701). The third wearable electrode 1702 may be connected to a patient's skin along with the left 801 and right 802 side wearable electrodes, thereby providing an increased number of electrode contacts on the patient's skin and increasing the quality of the collected ECG signal. In an alternative embodiment, the third wearable electrode 1702 may be used as a ground. In one embodiment, the second wire 1703 may retract into the right side 402. In an alternative embodiment, the second wire 1703 may retract into the third portion 1701. In one embodiment, the second wire 1703 may be detachable from the third portion 1701. In an alternative embodiment, the second wire 1703 simply may plug into a portion of the right side 402. In further embodiments, there may be an unlimited number of retractable or connectable wires which may retract or may connect to either the left 401 or right sides 402 for use in the collection of electrical signals from a patient's heart, for reference wires, or electrical grounds. For example, FIG. 17 also illustrates a simple wire 1704 that may be connected to the top of the right 402 side of the retractable multi-use cardiac monitor 110. Wire 1704 may be a ground or a signal wire.

[0088] FIG. 17 also illustrates a symptom button 1705. The symptom button 1705 may operate as described above with respect to FIG. 4. Additionally, the symptom button may be

used when a patient desires to collect a short amount of data by temporarily placing the retractable multi-use cardiac monitor 110 against the patient's body, or if the patient desires to collect data using the sensing connectors 903 and 904 as finger electrodes as discussed in FIGS. 15 and 16. In such an embodiment, only two of the left 401 and right 402 sides or the third portion 1701 may be active for the collection of ECG data. In such an embodiment, the symptom button 1705, or a dip switch or other means, may be used to indicate to the monitor that only two of three electrodes will be used. For example, the symptom button 1705, or a dip switch or other means, may be used to disable the right 402 side, leaving only the left side 401 and the third portion 1701 active for the collection of ECG data during temporary placement of the retractable multi-use cardiac monitor 110 against a portion of a patient's body. The non-designation of the right side 402 during data collection may advantageously eliminate any electrical noise that may be provided by the right side 402 during collection and may allow for electrical isolation of the left side 401 and right portion 1701 relative to one another.

[0089] FIG. 18 is a side-view of a retractable multi-use cardiac monitor, according to one embodiment of the present invention. FIG. 18 illustrates an embodiment where the wire 501 may retract into the right 402 side of the retractable multi-use cardiac monitor 110 using a single wire retraction barrel 1801 as a wire retractor. As discussed above, the wire 501 may retract into the left 401 side of the retractable multi-use cardiac monitor 110, and in such an embodiment the left 401 side may include a single wire retraction barrel as a wire retractor. FIG. 19 is also a side-view of a retractable multi-use cardiac monitor, according to one embodiment of the present invention. The embodiment illustrated in FIG. 19 includes left 401 and right 402 sides as well as a third portion 1701. The illustrated embodiment also includes a wire 501 and a second wire 1703. The wire 501 and second wire 1703 may retract into the right side 402 by a first 1902 and second 1903 retraction barrel, respectively, as wire retractors. The FIG. 19 embodiment also illustrates a third sensing connector 1901. FIG. 20 is a further illustration of a side-view of a retractable multi-use cardiac monitor 110, according to one embodiment of the present invention. In the FIG. 20 embodiment, the first retraction barrel 1902 may be within the left side 401 and the second retraction barrel 1903 may be within the third portion 1701. In the illustrated embodiment, the wire 501 may retract into the left side 401 by the first retraction barrel 1902, and the second wire 1703 may retract into the third portion 1701 by the second retraction barrel 1903.

[0090] FIG. 21 is yet another illustration of an embodiment of a retractable multi-use cardiac monitor 110. The illustrated embodiment includes left 401 and right 402 sides. The illustrated embodiment also includes a display screen 2101 which may be configured to display captured ECG or other biological data. FIG. 22 similarly illustrates an embodiment of a retractable multi-use cardiac monitor 110, where a display screen 2201 may be provided on the right side 402 in conjunction with the symptom button 403.

[0091] FIG. 23A is a flowchart illustrating the determination of an optimum set of electrode vector lengths, according to one embodiment. The embodiment of FIG. 23A is directed to the determination of an optimum set of electrode vector lengths with an embodiment of the retractable multi-use cardiac monitor 110 that may include both left 401 and right sides 402, as well as a third portion 1701 as illustrated, for example, and without limitation, in FIGS. 17, 19, and 20 and

discussed above. The FIG. 23A flowchart illustrates the steps of optimum electrode vector length determination from the perspective of a cardiac monitor (e.g. base unit 105 of FIG. 1 or smart phone of FIG. 3A), in an embodiment where a retractable multi-use cardiac monitor 110 may be used with another cardiac monitor to determine the optimum electrode vector length between the left 903 and right 904 sensing connectors, as well as the optimum electrode vector length between the right sensing connector 904 and the third sensing connector 1901. In step 2301, data may be received by the cardiac monitor (e.g. base unit 105 of FIG. 1 or smart phone of FIG. 3A) from the retractable multi-use cardiac monitor 110 representing a distance between the left 401 and right 402 sides of the retractable multi-use cardiac monitor 110 (and consequently left 903 and right 904 sensing connectors), as well as data representing a distance between the right side 402 and the third portion 1701 of the retractable multi-use cardiac monitor 110 (and consequently the right sensing connector 904 and the third sensing connector 1901). In some embodiments, if any of the left 401 side, right 402 side, or third portion 1701 have not moved since a previous iteration, a determination may be made by not sensing any such movement. In step 2302, ECG data collected by the retractable multi-use cardiac monitor 110 at the current distances between the left side 401, right side 402, and third portion 1701, respectively, may be received by the cardiac monitor (e.g. base unit 105 of FIG. 1 or smart phone of FIG. 3A). In step 2303, the received ECG collected data and the data representing the distance between the left 401 and right 402 sides, and the distance between the right side 402 and the third portion 1701 may be recorded by the cardiac monitor (e.g. base unit 105 of FIG. 1 or smart phone of FIG. 3A). The received ECG collected data and the data representing the distances between the left side 401, right side 402, and third portion 1701, respectively, may be recorded in a memory. Steps 2301 through 2303 may be repeated a number of times N with various distances between the left side 401, right side 402, and third portion 1701, respectively, of the retractable multi-use cardiac monitor 110. In some embodiments, the number of times N may be variable. In other embodiments, the number of times N may be constant. In yet other embodiments, the number of times N may be variable and may depend on intermediate calculations performed from the collected ECG data and distance values. In step 2304, a set of optimum electrode vector lengths between the left side 401, right side 402, and third portion 1701, respectively, may be calculated based on the ECG and distance data recorded in Step 2303 by the processor of the cardiac monitor (e.g. by the processor of base unit 105 of FIG. 1 or the processor of smart phone 301 of FIG. 3A). In step 2305, a notification may be generated indicating the optimum set of electrode vector lengths has been found. The notification may be generated by the cardiac monitor (e.g. base unit 105 of FIG. 1 or smart phone of FIG. 3A) or the retractable multi-use cardiac monitor 110. In some embodiments, the notification may be an audible noise. In other embodiments, the notification may be visual such as by a light or a display on a visual display (e.g. 2101 of FIG. 21 or 2201 of FIG. 22) of the retractable multi-use cardiac monitor 110, or by a light or a visual display on the display of a cardiac monitor (e.g. on a display 175 of base unit 105 of FIG. 1 or a display 305 of smart phone 301 of FIG. 3A).

[0092] In one embodiment, a set of optimum vector lengths may be calculated based on comparison of recorded signal strengths of ECG data at various vector distances collected by

Steps 2301 through 2303. In another embodiment, a set of optimum vector lengths may be calculated based on comparison of recorded signal fidelities of ECG data at various vector distances collected by Steps 2301 through 2303. In another embodiment, a set of optimum vector lengths may be calculated based on comparison of both recorded signal strengths as well as recorded signal fidelities of ECG data at various vector distances collected by Steps 2301 through 2303. In yet other embodiments, a set of optimum vector lengths may be calculated based on analyzing the ECG data at various vector distances collected by Steps 2301 through 2303 to determine if the collected ECG data represents a high fidelity QRS ECG pattern. In yet other embodiments, other signal quality measures may be used to calculate an optimum vector length. The intermediate calculations noted above in reference to FIG. 23A may be any of these operations.

[0093] FIG. 23B is a flowchart illustrating the determination of an optimum set of electrode vector lengths, according to one embodiment of the present invention. The FIG. 23B flowchart illustrates the steps of optimum electrode vector length determination from the perspective of a retractable multi-use cardiac monitor 110 in an embodiment where the retractable multi-use cardiac monitor 110 may determine an optimum set of electrode vector lengths by itself. Further, the FIG. 23B flowchart is directed to the determination of an optimum set of electrode vector lengths in an embodiment of the retractable multi-use cardiac monitor 110 that may include both left 401 and right sides 402, as well as a third portion 1701 as illustrated, for example, in FIGS. 17, 19, and 20 and discussed above. In step 2306, the retractable multi-use cardiac monitor 110 may determine a distance between the left 401 and right 402 sides of the retractable multi-use cardiac monitor 110 (and consequently left 903 and right 904 sensing connectors), and distance between the right side 402 and the third portion 1701 of the retractable multi-use cardiac monitor 110 (and consequently the right sensing connector 904 and the third sensing connector 1901). In some embodiments, if any of the left 401, right 402, or third portion 1701 have not moved since a previous iteration, a determination may be made by not sensing any such movement. Data representing each of the distances may be recorded. In step 2307, the retractable multi-use cardiac monitor 110 may collect and may record ECG data using each of the left 903, right 904, and third 1901 sensing connectors. The ECG data collected and the distances between the left side 401, right side 402, and third portion 1701, respectively, may be recorded in a memory of the retractable multi-use cardiac monitor 110. Steps 2306 and 2307 may be repeated a number of times N with various distances between the left side 401, right side 402, and third portion 1701, respectively. In some embodiments, the number of times N may be variable. In other embodiments, the number of times N may be constant. In yet other embodiments, the number of times N may be variable and may depend on intermediate calculations performed from the collected ECG data and distances between the left side 401, right side 402, and third portion 1701, respectively. In step 2308, a set of optimum electrode vector lengths between the left side 401, right side 402, and third portion 1701, respectively, may be calculated based on the ECG and distance data collected in Steps 2306 and 2307 by a processor of the retractable multi-use cardiac monitor 110. In step 2309, a notification may be generated indicating the optimum set of electrode vector lengths has been found. In some embodiments, the notification may be an audible noise. In other

embodiments, the notification may be visual such as by a light or a display on a display screen (e.g. **2101** of FIG. **21** or **2201** of FIG. **22**) of the retractable multi-use cardiac monitor **110**.

[0094] In one embodiment, a set of optimum vector lengths may be calculated based on comparison of recorded signal strengths of ECG data at various vector distances collected by Steps **2306** and **2307**. In another embodiment, a set of optimum vector lengths may be calculated based on comparison of recorded signal fidelities of ECG data at various vector distances collected by Steps **2306** and **2307**. In another embodiment, a set of optimum vector lengths may be calculated based on comparison of both recorded signal strengths as well as recorded signal fidelities of ECG data at various vector distances collected by Steps **2306** and **2307**. In yet other embodiments, a set of optimum vector lengths may be calculated based on analyzing the ECG data at various vector distances collected by Steps **2306** and **2307** to determine if the collected ECG data represents a high fidelity QRS ECG pattern. In yet other embodiments, other signal quality measures may be used to calculate an optimum vector length. The intermediate calculations noted above in reference to FIG. **23B** may be any of these operations.

[0095] FIG. **23C** is a flowchart illustrating the determination of a set of optimum electrode vector lengths, according to one embodiment of the present invention. The FIG. **23C** flowchart illustrates the steps of optimum electrode vector length determination from the perspective of a patient or a healthcare professional. In FIG. **23C**, the retractable multi-use cardiac monitor **110** alone or in combination with another cardiac monitor may be configured to assist the patient or healthcare professional with the determination of a set of optimum electrode vector lengths as explained in FIGS. **23A** and **23B** above. The embodiment of FIG. **23C** is directed to the determination of an optimum set of electrode vector lengths with an embodiment of the retractable multi-use cardiac monitor **110** that may include both left **401** and right sides **402**, as well as a third portion **14071** as illustrated, for example, in FIGS. **17**, **19**, and **20** and discussed above. In step **2310**, the patient or healthcare professional may adjust at least one of a distance between the left **401** and right **402** sides of the retractable multi-use cardiac monitor **110**, or a distance between the right side **402** and the third portion **1701**. In step **2310**, the patient or healthcare professional may adjust both distances. In step **2311**, the patient or healthcare professional may hold or may apply the retractable multi-use cardiac monitor **110** against a portion of a patient body to record data. Steps **2311** and **2312** may be repeated a number of times **N** with various distances between the left side **401**, right side **402**, and third portion **1701**, respectively. In some embodiments, the number of times **N** may be variable. In other embodiments, the number of times **N** may be constant. In yet other embodiments, the number of times **N** may be variable and depends on intermediate calculations performed from the collected data and distance adjustments. In step **2312**, the patient or healthcare professional may receive a notification indicating that the set of optimum electrode vector lengths has been found from either a cardiac monitor (e.g. base unit **105** of FIG. **1** or smart phone **301** of FIG. **3A**) or from the retractable multi-use cardiac monitor **110**, as explained above in the discussion of FIGS. **23A** and **23B**. In an alternative embodiment, the patient or healthcare professional may not receive a notification in step **2312**. Rather, the patient or healthcare professional may review the iteratively collected ECG data at various vector distances to determine the set of optimum

vector lengths. For example, the patient or healthcare professional may review such data on a display screen (e.g. **2101** of FIG. **21** or **2201** of FIG. **22**) of the retractable multi-use cardiac monitor **110**, on a display screen of a cardiac monitor (e.g. display **175** of base unit **105** of FIG. **1** or display **305** of smart phone **301** of FIG. **3A**).

[0096] One of skill in the art would recognize that the methods of determining a set of optimum vector lengths as disclosed above in reference to FIGS. **23A**, **23B**, and **23C** are similarly applicable to a retractable multi-use cardiac monitor **110** with any number of portions or sides that include sensing connectors or electrodes, or any number of wires that are connected to sensing connectors or electrodes.

[0097] The foregoing description of embodiments of the invention has been presented for purposes of illustration and description. It is not intended to be exhaustive or to limit the invention to the precise form disclosed, and modifications and variations are possible in light of the above teachings or may be acquired from practice of the invention. The embodiments were chosen and described in order to explain the principals of the invention and its practical application to enable one skilled in the art to utilize the invention in various embodiments and with various modifications as are suited to the particular use contemplated. Some of the illustrative aspects of the present invention may be advantageous in solving the problems herein described and other problems not discussed which are discoverable by a skilled artisan.

[0098] While the above description contains much specificity, these should not be construed as limitations on the scope of any embodiment, but as exemplifications of the presented embodiments thereof. Many other ramifications and variations are possible within the teachings of the various embodiments. While the invention has been described with reference to exemplary embodiments, it will be understood by those skilled in the art that various changes may be made and equivalents may be substituted for elements thereof without departing from the scope of the invention. In addition, many modifications may be made to adapt a particular situation or material to the teachings of the invention without departing from the essential scope thereof. Therefore, it is intended that the invention not be limited to the particular embodiment disclosed as the best or only mode contemplated for carrying out this invention, but that the invention will include all embodiments falling within the scope of the appended claims. Also, in the drawings and the description, there have been disclosed exemplary embodiments of the invention and, although specific terms may have been employed, they are unless otherwise stated used in a generic and descriptive sense only and not for purposes of limitation, the scope of the invention therefore not being so limited. Thus the scope of the invention should be determined by the appended claims and their legal equivalents, and not by the examples given.

That which is claimed is:

1. A retractable multi-use cardiac monitor, comprising:
 - a memory;
 - a first side comprising a first housing wherein a first sensing connector is on the outside of the first housing and is configured to collect electrocardiogram (ECG) data and store ECG data onto the memory;
 - a second side comprising a second housing including a wire retractor and a second sensing connector, wherein the second sensing connector is on the outside of the second housing and is configured to collect ECG data

and store ECG data onto the memory, and wherein the wire retractor is configured to extend and retract a wire that connects the second and first sides to vary a linear distance between the second and first sensing connectors, defined as an interelectrode distance; and a processor configured to calculate an optimum electrode vector length between the first sensing connector and the second sensing connector based at least in part on the ECG data and on the interelectrode distance.

2. The retractable multi-use cardiac monitor according to claim 1, wherein the second side further comprises a symptom button on the outside of the second housing opposite the second sensing connector.

3. The retractable multi-use cardiac monitor according to claim 1, wherein the first and second sensing connectors are configured to connect to wearable electrodes.

4. The retractable multi-use cardiac monitor according to claim 1, wherein the first and second sensing connectors are shaped to receive a finger.

5. The retractable multi-use cardiac monitor according to claim 1, further comprising:

a third portion comprising a third housing, wherein a third sensing connector is on the outside of the third housing and is configured to collect ECG data and store ECG data onto the memory; and

a second wire that connects the third portion to the second side, wherein a second wire retractor of the second side is configured to extend and retract the second wire to vary a linear distance between the third and second sensing connectors, defined as a second interelectrode distance.

6. The retractable multi-use cardiac monitor according to claim 1 further comprising a wireless radio configured to transmit the interelectrode distance and a portion of collected ECG data from the memory to a destination.

7. The retractable multi-use cardiac monitor according to claim 6, wherein the destination is a smart phone.

8. The retractable multi-use cardiac monitor according to claim 6, wherein the wireless radio is configured to directly transmit to a monitoring center as the destination.

9. The retractable multi-use cardiac monitor according to claim 1, further comprising a display screen that is configured to display collected ECG data.

10. A method of collecting electrocardiogram (ECG) data with a retractable multi-use cardiac monitor, wherein the retractable multi-use cardiac monitor includes a processor and a memory, a first side that includes a first housing wherein a first sensing connector is on the outside of the first housing, a second side including a second housing including a wire retractor and a second sensing connector, wherein the second sensing connector is on the outside of the second housing, and a wireless radio, the method comprising:

extending from the wire retractor a wire that connects the second and first sides to vary a linear distance between the second and first sensing connectors, defined as an interelectrode distance;

collecting ECG data from the first and second sensing connectors of the retractable multi-use cardiac monitor, wherein the first and second sensing connectors are placed against the skin of a patient;

recording the collected ECG data onto the memory of the retractable multi-use cardiac monitor;

calculating, using the processor, an optimum electrode vector length between the first sensing connector and the

second sensing connector based at least in part on the ECG data and on the interelectrode distance; and transmitting the interelectrode distance and a portion of the collected ECG data to a destination.

11. The method of collecting electrocardiogram (ECG) data according to claim 10, wherein the second side of the cardiac data monitor further comprises a symptom button on the outside of the second housing opposite the second sensing connector, the method further comprising:

receiving an indication that the symptom button of the retractable multi-use cardiac monitor has been pressed; and

transmitting an indication that the symptom button of the retractable multi-use cardiac monitor has been pressed to the destination.

12. The method of collecting cardiac electrocardiogram (ECG) according to claim 10, wherein the first and second sensing connectors of the retractable multi-use cardiac monitor are configured to connect to wearable electrodes.

13. The method of collecting cardiac electrocardiogram (ECG) according to claim 10, wherein the first and second sensing connectors are shaped to receive a finger, and wherein the first sensing connector is placed against a first finger of a first hand of the patient and the second sensing connector is placed against a second finger of a second hand of the patient.

14. The method of collecting cardiac electrocardiogram (ECG) according to claim 10, wherein the retractable multi-use cardiac monitor further includes a third portion including a third housing, wherein a third sensing connector is on the outside of the third housing, the method further comprising:

extending from a second wire retractor of the second side a second wire that connects the third portion and second side to vary a linear distance between the third and second sensing connectors, defined as a second interelectrode distance; and

collecting ECG data from the third sensing connector of the retractable multi-use cardiac monitor, wherein the third sensing connector is placed against the skin of the patient.

15. The method of collecting cardiac electrocardiogram (ECG) according to claim 10, wherein the transmitting step comprises transmitting the interelectrode distance and the portion of collected ECG data directly to at least one of a monitoring center and a smart phone as the destination.

16. The method of collecting cardiac electrocardiogram (ECG) according to claim 10, wherein the retractable multi-use cardiac monitor includes a display screen, the method further comprising:

displaying a portion of collected ECG data on the display screen.

17. A method of determining an optimum electrode vector length between a first sensing connector of a first side of a retractable multi-use cardiac monitor and a second sensing connector of a second side of the retractable multi-use cardiac monitor, comprising:

performing at least one data collection comprising the steps of:

determining a distance between the first sensing connector of the retractable multi-use cardiac data monitor and the second sensing connector of the retractable multi-use cardiac data monitor, wherein the distance defines an interelectrode distance, recording the interelectrode distance,

collecting electrocardiogram (ECG) data through the first and second sensing connectors, and recording the collected ECG data;

calculating an optimum electrode vector length between the first sensing connector of the first side of the retractable multi-use cardiac monitor and the second sensing connector of the second side of the retractable multi-use cardiac monitor based on the ECG data recorded in the at least one data collection and the interelectrode distance recorded in the at least one data collection;

generating a notification of that the optimum electrode vector length has been found.

18. The method of determining the optimum electrode vector length according to claim **17** wherein the at least one data collection further comprises a plurality of data collections; wherein collecting ECG data further comprises recording an ECG signal strength collected by the first sensing connector and the second sensing connector as positioned at a respective distance during each of the plurality of data

collections; and wherein calculating the optimum electrode vector length further comprises comparing the ECG signal strengths.

19. The method of determining the optimum electrode vector length according to claim **17** wherein the at least one data collection further comprises a plurality of data collections; wherein collecting ECG data further comprises recording an ECG fidelity collected by the first sensing connector and the second sensing connector as positioned at a respective distance during each of the plurality of data collections; and wherein calculating the optimum electrode vector length further comprises comparing the ECG fidelities.

20. The method of determining the optimum electrode vector length according to claim **17** wherein calculating the optimum electrode vector length further comprises:

determining that the ECG data represents a high fidelity QRS ECG pattern, and
setting the optimum electrode vector length to equal the interelectrode length.

* * * * *

专利名称(译)	用于可伸缩多用途心脏监测器中的电极间距离优化的系统和方法		
公开(公告)号	US20150150471A1	公开(公告)日	2015-06-04
申请号	US14/616801	申请日	2015-02-09
[标]申请(专利权)人(译)	MEDICOMP		
申请(专利权)人(译)	Medicomp , INC		
当前申请(专利权)人(译)	MEDICOMP INC.		
[标]发明人	BALDA DANIEL		
发明人	BALDA, DANIEL		
IPC分类号	A61B5/0408 A61B5/044 A61B5/00 A61B5/0432		
CPC分类号	A61B5/0408 A61B5/0006 A61B5/044 A61B5/04325 A61B5/0404 A61B5/6823 A61B5/6826 A61B2560/045 A61B2562/221		
优先权	61/347117 2010-05-21 US		
其他公开文献	US9226679		
外部链接	Espacenet USPTO		

摘要(译)

提供一种可伸缩的多用途心脏监测器，其包括存储器，以及分别位于第一和第二壳体外部的第一和第二传感连接器。第一和第二传感连接器被配置为检测作为ECG数据存储在存储器上的心电图（ECG）信号。可伸缩多用途心脏监测器的第二壳体还包括线牵开器，该线牵开器构成延伸和缩回连接第二和第一壳体的线，并限定第一和第二传感连接器之间的电极间距离。可伸缩的多用途心脏监测器还包括用于确定电极间距离的长度的系统和方法，其在检测到的ECG信号的强度和保真度方面是最佳的。可伸缩的多用途心脏监测器还包括无线电台，其被配置为将存储的ECG数据的一部分从存储器发送到目的地。

