



US 20140296669A1

(19) **United States**
(12) **Patent Application Publication**
Gertsch et al.

(10) **Pub. No.: US 2014/0296669 A1**
(43) **Pub. Date: Oct. 2, 2014**

(54) **ELECTRONIC HEADWEAR**

Publication Classification

(71) Applicant: **TRI-MATE PRO, INC.**, (US)
(72) Inventors: **Bruce Gertsch**, San Diego, CA (US);
Ronald Gertsch, San Diego, CA (US);
Paul Nysen, Pala, CA (US); **Peter Nysen**, San Jose, CA (US); **William Swanson**, San Diego, CA (US);
Christopher L. Gehrisch, Vista, CA (US); **Martin D. McCune**, San Diego, CA (US); **David L. Williams**, San Diego, CA (US)

(51) **Int. Cl.**
A61B 5/00 (2006.01)
A61B 5/0205 (2006.01)
A61B 5/01 (2006.01)
A61B 5/1455 (2006.01)
(52) **U.S. Cl.**
CPC *A61B 5/6803* (2013.01); *A61B 5/14552* (2013.01); *A61B 5/02055* (2013.01); *A61B 5/01* (2013.01); *A61B 5/0008* (2013.01); *A61B 5/02427* (2013.01)
USPC **600/324**

(73) Assignee: **TRI-MATE PRO, INC.**, San Diego, CA (US)

(21) Appl. No.: **13/853,526**

(22) Filed: **Mar. 29, 2013**

(57) **ABSTRACT**

A headwear assembly is provided that measures physiological changes, e.g., oxygen saturation, pulse, blood pressure, and body temperature of a user during physical exercise, to include athletic activities and other situations. The headwear assembly can provide integrated functionality with an external device such as a smart phone. The headwear assembly can be embodied in various configurations, e.g., stand-alone headband, cap, visor, or a helmet.

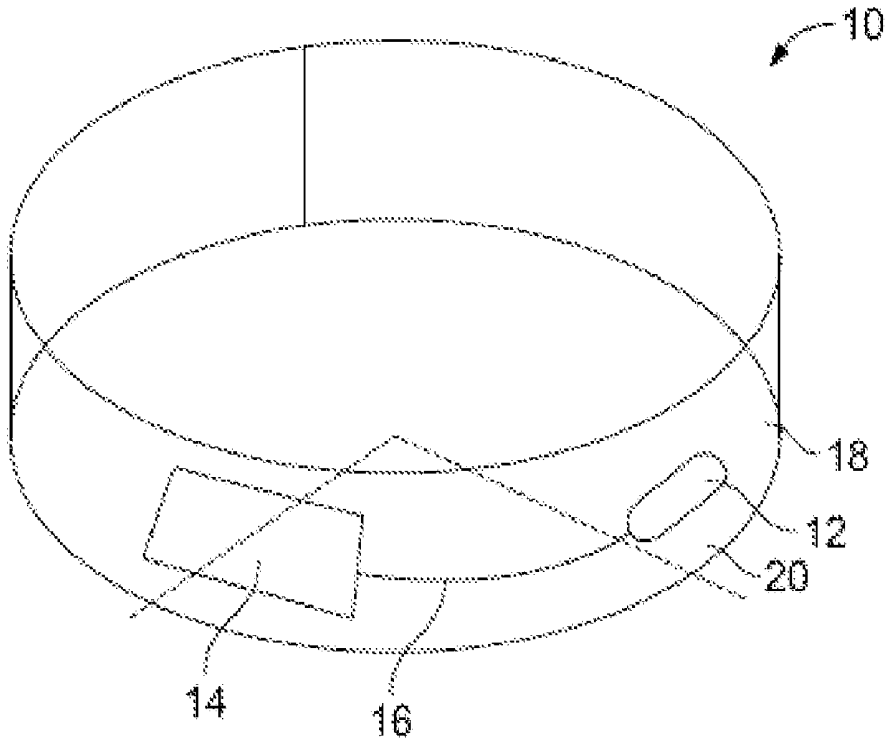

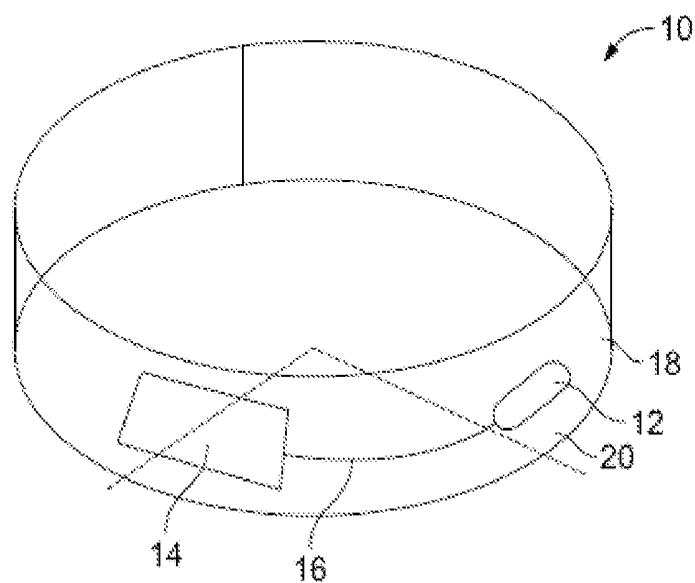

FIG. 1A

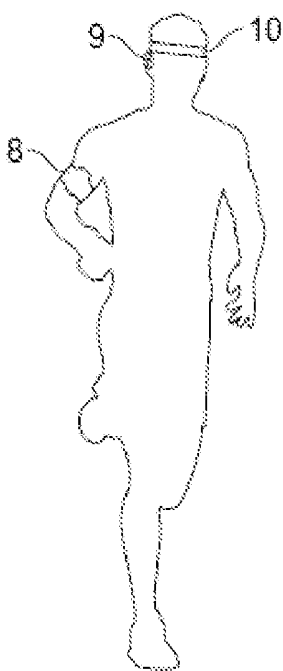

FIG. 1B

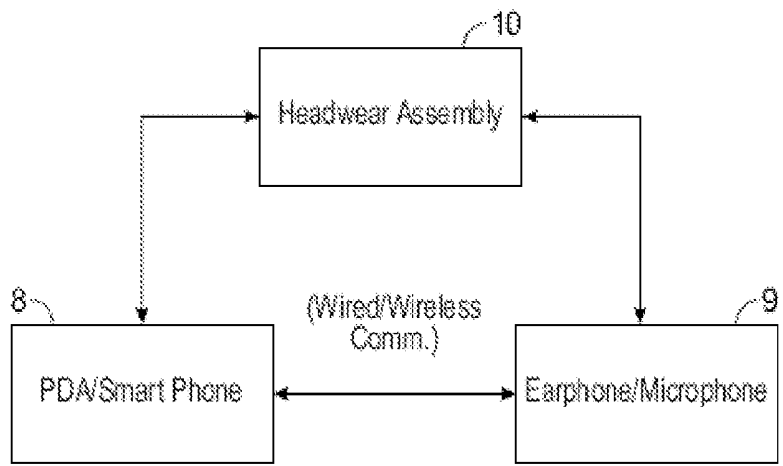

FIG. 1C

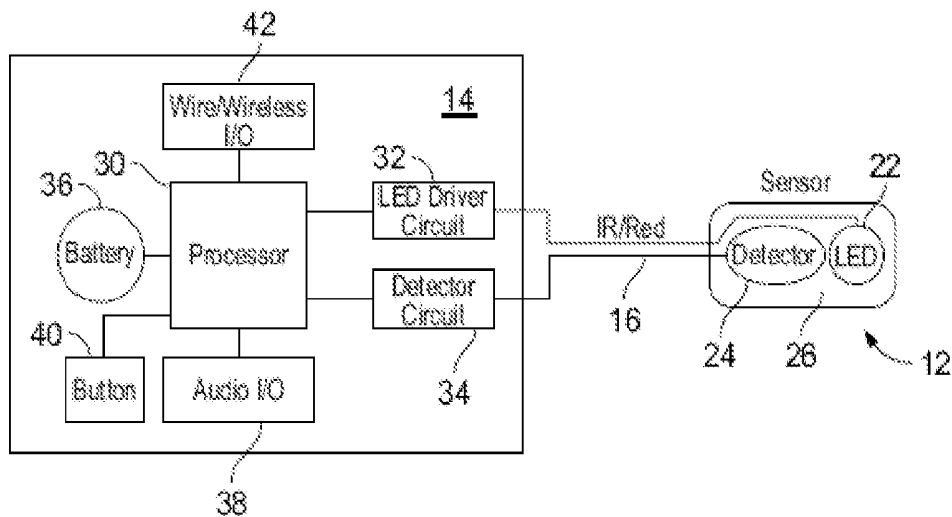

FIG. 2

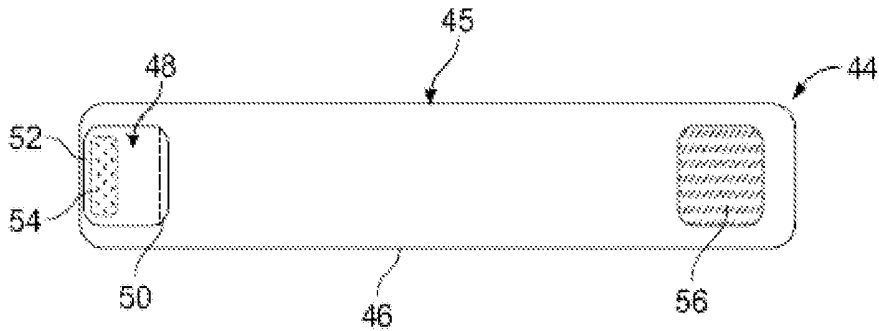

FIG. 3

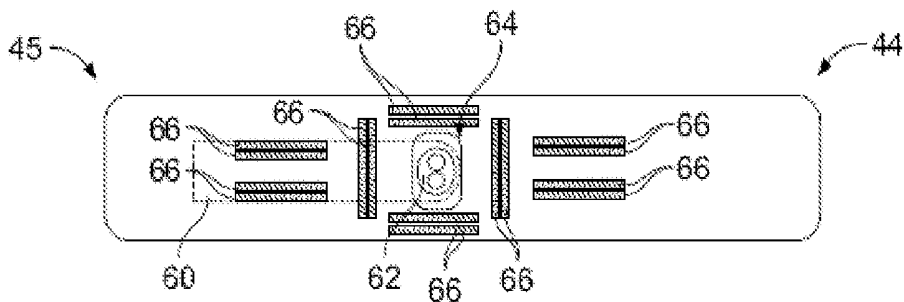

FIG. 4

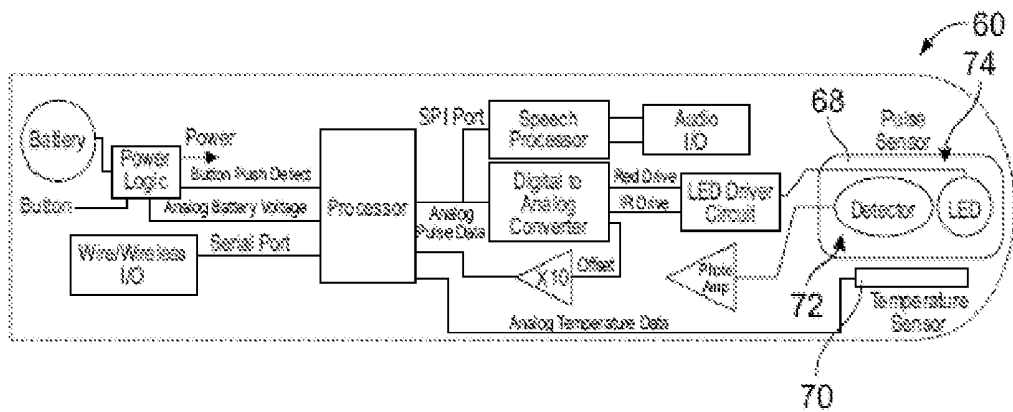
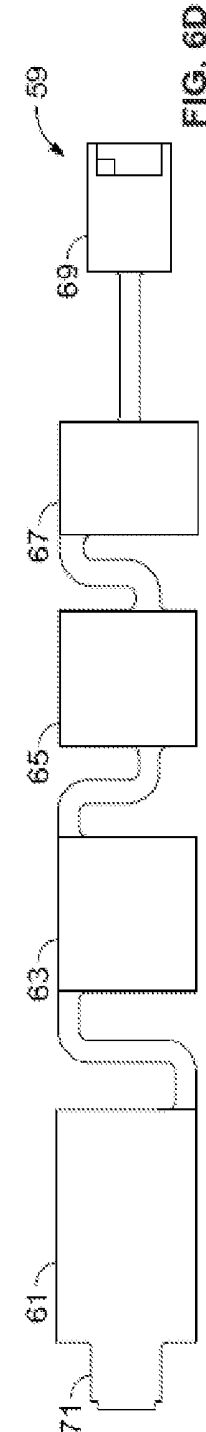
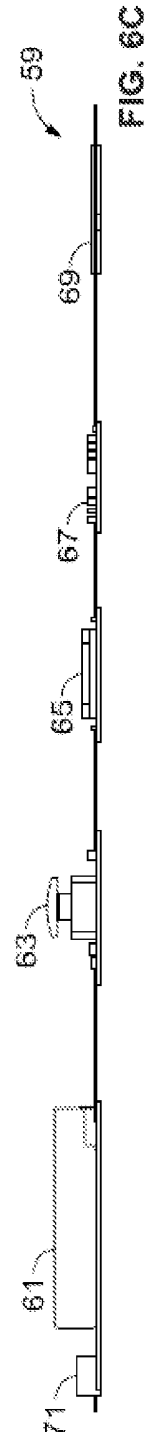
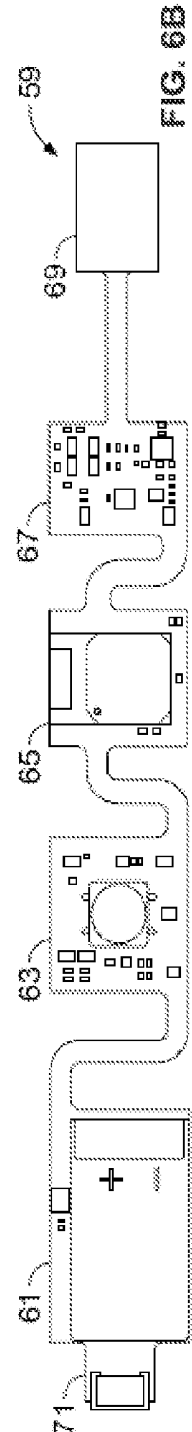
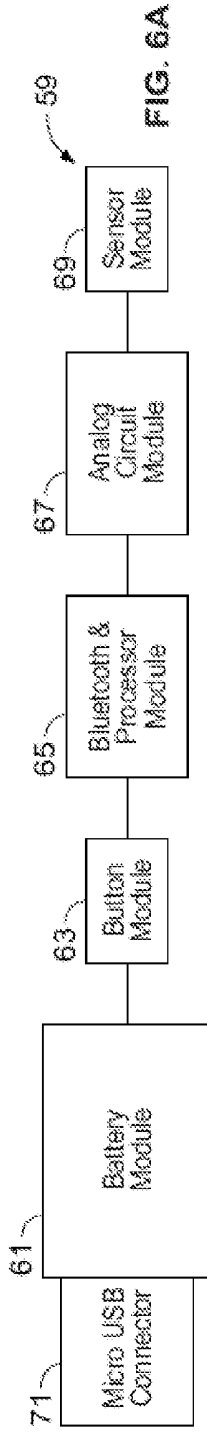

FIG. 5



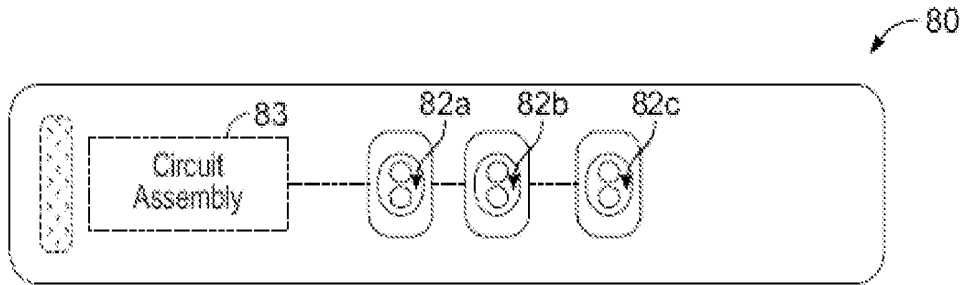

FIG. 7

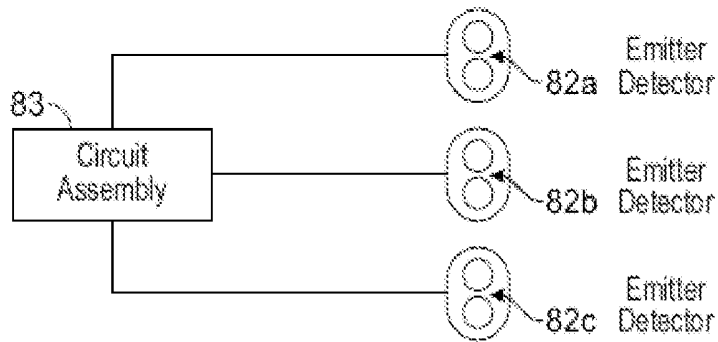

FIG. 8

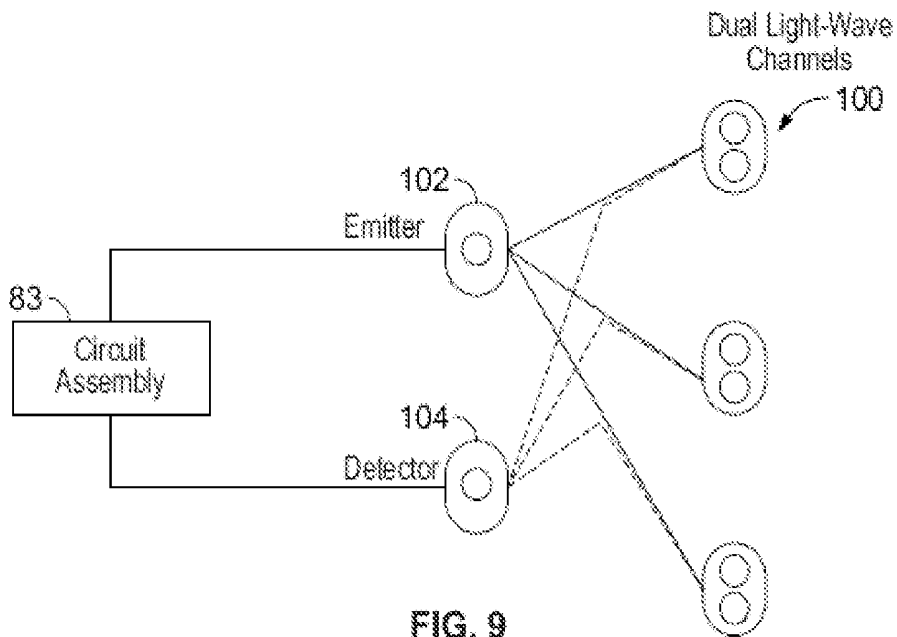

FIG. 9

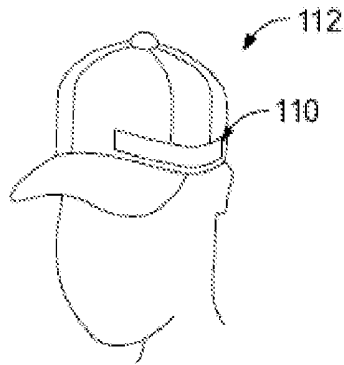
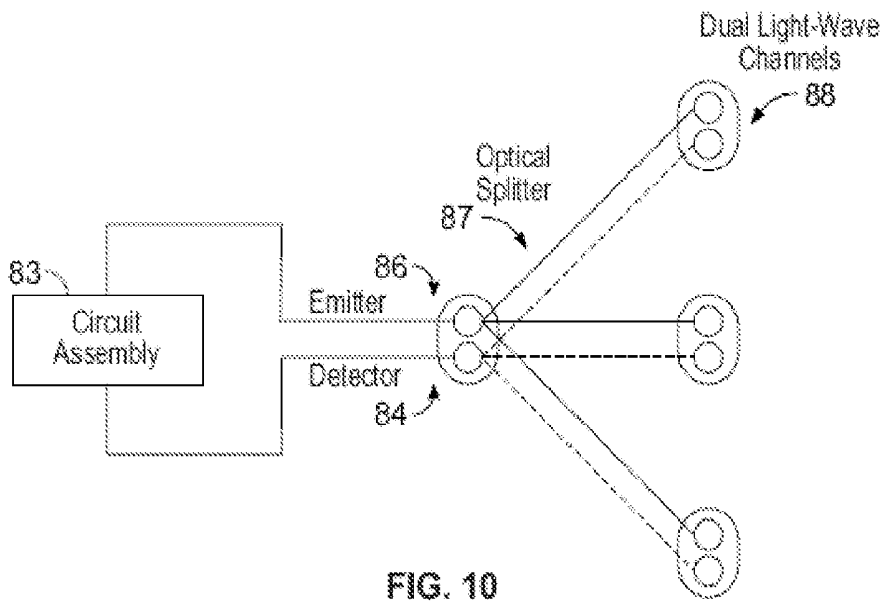

FIG. 11a

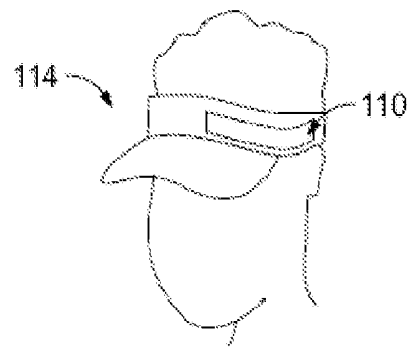

FIG. 11b

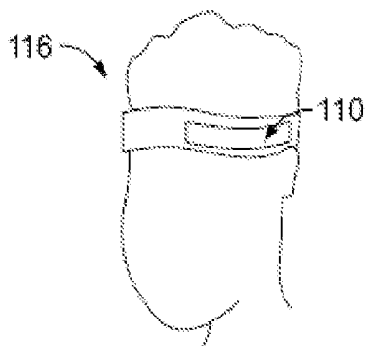

FIG. 11c

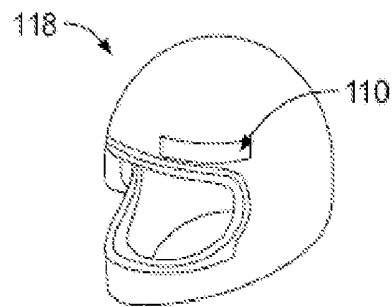

FIG. 11d

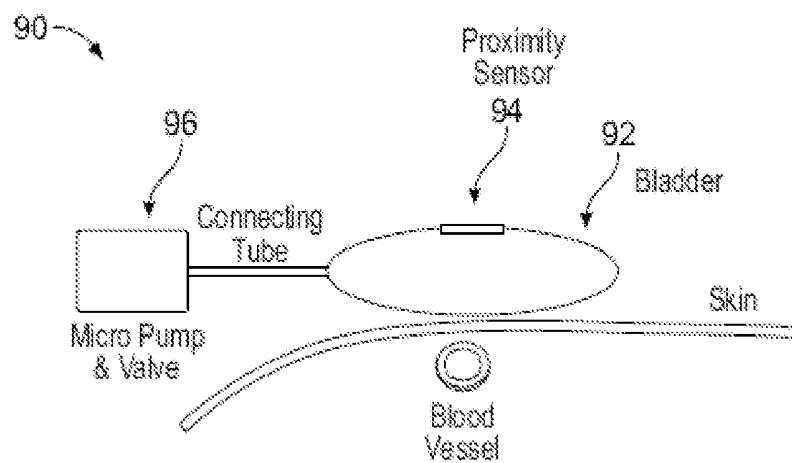

FIG. 12

ELECTRONIC HEADWEAR

FIELD OF THE INVENTION

[0001] The present invention relates generally to athletic headwear and, more particularly, headwear having a variety of physiological sensors, such as oxygen saturation, body temperature, pulse rate, and blood pressure.

BACKGROUND OF THE INVENTION

[0002] There has been an increasing interest in using devices and tools during exercise and athletic activities to enhance performance and also to monitor critical conditions. Measuring physiological characteristics during exercises can optimize workout routines. One such tool is an oximetry unit, which measures the oxygen saturation in blood and pulse rate. During intense exercise or at higher altitudes, there is a tendency for blood oxygen levels to drop. When the body is deprived of an adequate supply of oxygen, generalized hypoxia or tissue hypoxia may occur. Therefore, monitoring blood oxygen levels with an oximetry unit can be used to guide exercise, athletic training, and provide an alarm in critical conditions and situations.

[0003] Oximetry is a noninvasive assessment of arterial oxygen saturation (SpO₂), which is the measurement of the amount of oxygen carried by hemoglobin in the blood stream. It relies on Beer-Lambert's law, which states that the concentration of an absorbing substance in a solution is related to the intensity of light transmitted through that solution. Accordingly, an oximetry unit uses small light-emitting diodes (LED) to transmit light and then measures the light not absorbed by the tissue by a photodetector to determine the concentration of oxygen in blood. An oximetry unit emits light of at least two different wavelengths, red (660 nm) and infrared (905, 910, 940 nm). Deoxyhemoglobin (hemoglobin not combined with oxygen) has a higher optical extinction in the red region of the light spectrum compared to oxyhemoglobin (hemoglobin that is combined with oxygen). In contrast, in the infrared region, the optical absorption of deoxyhemoglobin is lower than oxyhemoglobin. Thus based on the differences in light absorption, an oximetry unit can measure the amount of light absorbed to calculate the percentage of oxygen saturation in blood.

[0004] The oximetry sensor is usually placed on a thin part of the body such as a fingertip or an earlobe. Since oximetry sensors have been predominantly used for clinical or medical purposes, the site of the oximetry sensor placement has generally not been an issue because multiple satisfactory placement sites are readily available. However, during exercise or other athletic activities, traditional locations for oximetry sensor placement such as fingertip or earlobe can be problematic.

[0005] It should be appreciated that there remains a need for an assembly that easily measures physiological vital sign changes such as oxygen saturation, pulse, body temperature, and blood pressure of a user during physical exercise, athletic activities, and other critical situations. The present invention addresses this need and others.

SUMMARY OF THE INVENTION

[0006] Briefly, and in general terms, the invention provides an electronic headwear assembly, such as a self-contained electronic strap, that measures physiological changes, e.g., oxygen saturation, pulse, blood pressure, and body tempera-

ture of a user during physical exercise and other critical situations, as well as providing other functions and data, such as wireless communications (e.g., Bluetooth® and Wi-Fi transceivers), altitude, average speed, distance, time, number of calories burned, LED headlamp, mobile phone, radio/music player, USB port, and battery parameters, among others. The headwear assembly has multiple embodiments that encompass various types of headwear. Not only can the headwear assembly be used in a stand-alone headband, it can be placed inside the headband of a cap or visor, or in the lining of a helmet. The LED headlamp can be located approximately in the center of the outer front portion of the headwear, e.g., cap, visor, and headband.

[0007] In various embodiments in accordance with the invention, the headwear assembly can provide: integrated functionality with multitudes of functions of an external device such as a smart phone via wireless Bluetooth® or Wi-Fi transceivers (e.g., to announce, display, or record physiological data). The external device may have either wired or wireless connection for listening or corresponding to allow for two-way communication.

[0008] When placed in a headwear assembly, a preferred location for the oximetry sensor is in the front section and proximate to the forehead when worn. In an exemplary embodiment, the headwear assembly is a self-contained unit that is housed in a flexible material with a plurality of attachment means, such as hook-and-loop fasteners, for adjustability and attachment. In a headband embodiment, the headwear assembly can be rotated 180 degrees upside down for use on either the left or right side. The front of the headwear assembly can be marked to indicate the proper position of the oximetry sensor, so that the user can ensure that the oximetry sensor is in the appropriate location on the user's forehead. Moreover, the cap, visor, and headband embodiments can be rotated in a variety of ways that allow the sensors to remain in a proper location proximate to the skin without interference, and also with the speakers in proximity to the ears.

[0009] In an exemplary embodiment, the headwear assembly includes an oximetry sensor and a flexible circuit board assembly that is separately spaced apart from and electrically coupled to the oximetry sensor by a wire, flexstrip, or other means. More specifically, the oximetry sensor and circuit board assembly are confined in a flexible waterproof or water resistant casing.

[0010] In a detailed aspect of an exemplary embodiment, the present invention provides an oximetry sensor, having an LED and photodetector sensor, which measures percentage of oxygen saturation, and pulse rate.

[0011] In another detailed aspect of an exemplary embodiment, the circuit board assembly includes a LED driver circuit, a detector circuit, processor, and battery. The circuit board can further be defined to include a speaker or other sound/vibration generators or sensors including remote two-way devices, wired or wireless. In one aspect, the circuit board assembly is programmable to provide physiological data, such as body temperature, blood pressure, oxygen saturation, pulse and alarms for high and low levels, to the user through the speaker. In another aspect, audio prompts are announced periodically by way of the speaker to the user at preprogrammed levels.

[0012] In yet another detailed aspect of an exemplary embodiment, the circuit board assembly includes a wireless transceiver. In this manner, physiological data can be transmitted wirelessly to a recorder and display unit, such as a

smart phone, that could be worn, for example, on the arm, wrist, and other part of the body.

[0013] Furthermore, in another exemplary embodiment, the circuit board assembly includes a control button accessible on the headwear body, the control button coupled to the processor. In one aspect, a user can manually press the control button to prompt the present invention to take a reading of the user's current physiological characteristics. Alternatively, the present invention is continuously measuring the user's physiological characteristics and manually pressing the button will provide data through audio announcements or visually through a display unit. Moreover, the central button can be activated from an external device whether connected by cable or wirelessly as previously described. Moreover, audio announcements can be initiated by voice activation commands.

[0014] For purposes of summarizing the invention and the advantages achieved or implemented over the prior art, certain advantages of the invention have been described herein. Of course, it is to be understood that not necessarily all such advantages may be achieved or implemented in accordance with any particular embodiment of the invention. Thus, for example, those skilled in the art will recognize that the invention may be embodied or carried out in a manner that achieves, optimizes, or implements one advantage or group of advantages as taught herein without necessarily achieving or implementing other advantages as may be taught or suggested herein.

[0015] All of these embodiments are intended to be within the scope of the invention herein disclosed. These and other embodiments of the present invention will become readily apparent to those skilled in the art from the following detailed description of the preferred embodiments having reference to the attached figures, the invention not being limited to any particular preferred embodiment disclosed.

BRIEF DESCRIPTION OF THE DRAWINGS

[0016] Embodiments of the present invention will now be described, by way of example only, with reference to the following drawings in which:

[0017] FIG. 1A is a perspective view of a headwear assembly in accordance with the present invention, depicting sensors and a circuit board assembly that are spaced apart and electrically coupled together.

[0018] FIG. 1B is an elevational view depicting a user wearing the headwear assembly of FIG. 1, further wearing a smart phone housed in an armband and wireless earphones, the headwear assembly and smart phone wirelessly and operatively connected.

[0019] FIG. 1C is a simplified block diagram of the headwear assembly, smartphone, and earphones of FIG. 1B.

[0020] FIG. 2 is a simplified block diagram of the sensors and the circuit assembly of the headwear assembly of FIG. 1.

[0021] FIG. 3 is plan view of the headwear assembly of FIG. 1, depicting the front surface of the headband laid open, including an attachment tab for coupling opposing ends of the headband together.

[0022] FIG. 4 is a plan view of a second embodiment of a headwear assembly in accordance with the invention, depicting an interior side of a headband, laid open, and an electronic strap having a sensing end exposed through an aperture of the headband.

[0023] FIG. 5 is a simplified block diagram view of the electronic strap of FIG. 4.

[0024] FIG. 6a is a simplified block diagram of an electronic strap in accordance with the invention.

[0025] FIG. 6b is a top view of the electronic assembly of the electronic strap of FIG. 6a.

[0026] FIG. 6c is a side view of the electronic assembly of the electronic strap of FIG. 6a.

[0027] FIG. 6d is a bottom view of the electronic assembly of the electronic strap of FIG. 6a.

[0028] FIG. 7 is a plan view of a third embodiment of a headwear assembly in accordance with the invention, depicting an interior side of a headband, laid open, having multiple sensing sections exposed through apertures of the headband.

[0029] FIG. 8 is a simplified block diagram view of the sensors and the circuit assembly of the headwear assembly of FIG. 7.

[0030] FIG. 9 is a simplified block diagram view of sensors and the circuit assembly of another embodiment of a headwear assembly in accordance with the invention.

[0031] FIG. 10 is a simplified block diagram view of sensors and the circuit assembly of another embodiment of a headwear assembly in accordance with the invention.

[0032] FIGS. 11a-11d are perspective views of an electronic strap disposed in various headwear assemblies in accordance with the invention.

[0033] FIG. 12 is a cross-sectional view of a blood pressure sensor for use in selected embodiments of a headwear assembly in accordance with the invention.

DETAILED DESCRIPTION OF THE PREFERRED EMBODIMENTS

[0034] Referring now to the drawings, and particularly FIGS. 1A-1C, there is shown a headwear assembly 10 having an oximetry sensor (emitter/detector) 12 (This may include other sensors, such as temperature, blood pressure, etc.) and a circuit board assembly 14 that is spaced apart from and electrically coupled to the oximetry sensor (emitter/detector) by a wire/flexstrip 16, an air-tube, or other means. The headwear assembly 10 includes a headband 18. The oximetry emitter/detector 12 is located in a front section 20 of the headband, proximate to the forehead when worn. When the headwear assembly is worn, the oximetry sensor is positioned on one side of the user's lower forehead substantially above the eyebrows/eyes.

[0035] The position of the sensor 12 is advantageous for exercising or engaging in physical or other activities over both fingertip and earlobe oximetry sensor. Generally, for most physical activity, a headband is less obtrusive during exercise than an ear or finger sensor. Additionally, a person engaged in certain sports, such as tennis, cycling, running, or basketball, may be already accustomed to wearing headwear. Moreover, when compared to a fingertip oximetry sensor, a headband oximetry unit is advantageous, because it is a less active site during exercise. While the sensors are optimally located above the eyes, the electronic package may be conveniently and ergonomically located anywhere in the headband system including either side, back or front of the head.

[0036] Referring to the drawing in FIGS. 1B and 1C, the headwear assembly 10 will operate with external units, such as a PDA (personal data assistant), smart phone (8), and a headset or earphone microphone system (9). These may communicate either directly by wire/cable or by wireless means.

[0037] Due to the natural placement of a headband during exercise, the oximetry sensor 12 will be located optimally above the eyebrow. When properly worn in the preferred

location, the LED emitter **22** and detector **24** (FIG. 2) of the oximetry sensor **12** lie above the eyebrow in the region of the most dense near surface blood flow.

[0038] In one embodiment, the headband **18** is made of a fabric that is wickable, stretchable, and breathable material, e.g., such as Dryline or spandex. The fabric can also be antimicrobial for odor control and stain resistant.

[0039] The user can rotate the headwear assembly **10** flipped upside down to have the oximetry sensor **12** located for use on either the left or right side of the user. The front **20** of the headband can be marked with the location of the sensor so the user can position the oximetry sensor in the appropriate location on the user's forehead.

[0040] The sensors **12** and circuit board **14** are confined in a flexible waterproof casing that is at least transparent in the region between the sensors **12** and the user's skin. In an exemplary embodiment, the sensors and circuit board are arcuate to conform comfortably to the user's forehead. Alternatively, the sensors and circuit board are encased in flexible material that will conform to the user's head when worn.

[0041] Furthermore, the wire (or air-tube) assembly **16** that connects the sensors and circuit board may include a waterproof or water resistant material or is confined in waterproof casing, and is flexible to conform to the user's head when the headwear assembly is worn.

[0042] With reference to FIG. 2, the oximetry sensor **12** includes the emitter (LED) **22** and the detector **24** mounted to flexible, waterproof substrate **26**. The LED and detector are placed adjacent to each other. The configuration of the sensor assembly is designed to minimize the amount of ambient light in the sensing area.

[0043] In the exemplary embodiment, the LED **22** emits at least two distinct wavelengths of light: red and infrared light. The detector is a photodetector capable of detecting the wavelengths of light emitted by the LED.

[0044] More particularly, The LED **24** emits light at two wavelengths (e.g., (1) 660 nm (red light); (2) 905, 910, or 940 nm (infrared light)). As light passes through tissue, oxyhemoglobin absorbs infrared light and allows red light to pass through, while deoxyhemoglobin does the opposite and absorbs red light but allows infrared light to pass through. Via the detector **24**, the assembly measures the absorption ratio of the red and infrared light. The percentage of oxygen saturation is then calculated. To calculate the ratio of oxygen saturation, by a means known to those versed in the art, as blood pulses and fades with each heartbeat, the measurement of oxygen absorption from the peak level of the pulse is subtracted from the measurement of oxygen absorption at the lower level. In other embodiments, additional or alternative approaches can be used to measure pulse rate, e.g., such as utilizing blood pressure sensors as discussed herein below.

[0045] With continued reference to FIG. 2, the circuit board assembly **14** includes a processor **30**, LED driver circuit **32**, detector circuit **34**, and battery **36**. The circuit board assembly is connected to the sensor assembly **12**. The processor **30** connects to the LED **22** through the LED driver circuit **32**. After instructions to the LED **22** have been sent, the processor **30** receives the light absorption measurement data from the detector **24**, through the detector circuit **34**. The battery **36** powers the circuit assembly **14** and the sensors **12**. The battery can be replaced. Alternatively, a rechargeable battery may be used. Charging of the battery may be via direct connection such as a USB connector or the LIKE or remotely using an inductive (magnetic) coupling method.

[0046] In a detailed aspect of an exemplary embodiment, the circuit board **14** contains memory that is coupled to the processor **14**, making it programmable to provide customizable data to the user, which includes body temperature, oxygen saturation, pulse, blood pressure, and alarms for high or low levels and battery level. In another aspect, the headwear assembly can be programmed to announce periodic audio prompts by way of a speaker **38** at preprogrammed intervals or indirectly via an ear piece/microphone connection, either wired or wireless connected. Moreover, audio announcements can be initiated by voice activation commands.

[0047] In other embodiments, various other headwear configurations can be used. A speaker can be located proximate to an ear of the user, on either the left or right side, or both. Moreover, the cap, visor, and headband embodiments can be rotated in a variety of ways that allow the sensors to remain in a proper location proximate to the skin without interference, and also preferably, with the speakers in proximity to the ears.

[0048] In an exemplary embodiment, the circuit board assembly **14** further includes a button **40** and a wireless transceiver **42** such as Bluetooth®, Wi-Fi, or inductively coupled loop the like of which is used in many hearing aids. The button **40** is coupled to the processor **30** and powers the device on or off. In one aspect, the user can also press the button **40** to prompt the headwear assembly to take measurements. In another aspect, the user can press the button **40** to provide data through audio announcements using the speaker **38** or audibly/visually through a wireless transceiver **42** to a display unit such as a mobile phone or audibly through a listening device wired or wireless which is connected to an electronic device such as a mobile phone, such as shown in FIG. 1C.

[0049] With reference now to FIG. 3, a front surface **46** of another embodiment of a headwear assembly **44** is shown. The headwear assembly **44** includes a headband **45** having an attachment tab **48** having a proximal portion **50** coupled to the front surface and a free distal end **52**. An attachment tab includes a first portion **54** of an attachment assembly that mates with a corresponding second portion **56** of the attachment assembly disposed on an opposing end of the headband. The attachment assembly can be any number of those known in the art, e.g., hook and loop, snaps, fasteners, and other means. The attachment tab **48** provides adjustable tension to securely attach to the user's head during exercise or athletic activities.

[0050] With reference now to FIG. 4, there is shown an interior side of a headwear assembly **44**, laid open, including an electronic strap **60** having a sensing end **62** exposed through an aperture (e.g., transparent window) **64** the headband **45**. The interior side of the headband includes several slip-resistant bands **66** disposed about the aperture to maintain the position and minimize exposure to ambient light of the sensing end, thereby maintaining the accuracy of readings. The slip-resistant band can be formed of polymeric material secured to the interior side. The slip resistance bands ideally should be interrupted rather than a single continuous band to give the best immobilization effect possible even in moisture environments because movement of any particular single band will not affect movement in any of the others.

[0051] With reference now to FIG. 5, the electronic strap **60** includes a circuit board that house all components, including a pulse and oxygen saturation sensor **68** and a temperature sensor **70** at the sensing end. The pulse sensor includes a detector **72** and an LED **74**. The pulse sensor is connected to an LED driver circuit, which communicates with a processor

via a digital to analog convertor (D/A convertor). The detector communicates with the processor via a photo amplifier. The body temperature is obtained by a temperature sensor (e.g., thermistor), which is located adjacent to the sensor **68**. The electronic strap further includes a speaker, a transducer, and a speaker processor that enables the strap to announce measurements to the wearer. The electronic strap can communicate bi-directionally with other devices via wireless communications, e.g., Bluetooth®, WI-FI, or inductive means. The microphone and related processor enable the strap to receive and process verbal commands from the user.

[0052] With reference now to FIGS. **6a-6d**, an electronic strap **59** is shown, configured to facilitate comfort and flexibility when worn against the head with the sensing end positioned to be disposed in an appropriate location for accurate measurements when worn. Components are distributed about the several circuit boards connected via bridge connections (e.g., flex wire, thin bridge of circuit board).

[0053] As best seen in FIG. **6a**, the electronic strap **60** includes a battery module **61**, button module **63**, communications (e.g., Bluetooth®, WIFI) and processor module **65**, analog circuit module (analog) **67**, and a sensor module **69**. A USB connector **71** is disposed adjacent and operatively coupled to the battery module.

[0054] With reference now to FIGS. **7 to 10**, the headwear assembly **80** can include a plurality of sensors **82(a,b,c)** for oximetry and/or for blood pressure (e.g., **90** of FIG. **12**), in which such sensors are disposed in spaced relationship in prescribed locations about the headwear assembly to measure various selected locations on the user, when worn. The advantage of multiple sensors is that the unit can obtain the strongest and most accurate reading from multiple readings.

[0055] With reference now to FIG. **8**, multiple sensors may be electronically or optically connected back to the circuit assembly **83**. When optically connected the emitter/sensor units **82(a,b,c)** may be included with the circuit assembly and optical wave-guides used to transfer the sensing light to and from the monitoring point. The plurality of sensors may be connected to the processing unit individually, multiplexed, or aggregated to a sensor block or a combination of all three means.

[0056] In the embodiments of FIGS. **9 and 10**, the oximetry sensors include channels for directing light, e.g., lightwave guides or fiber optics **100**, that are positioned to direct light to the measuring location on the user. In this manner, other components of the sensor can be spaced apart from the measuring location. For example, components of the oximetry sensor can be mounted on the circuit board along or in conjunction with use of light wave guides or optical fibers for skin contact. An advantage of the multiple light wave fibers over multiple sensors is that only one sensor pair (emitter **102** and detector **104**) is needed and the smaller multiple light wave fibers can allow for more sensor data collection in a limited space. FIG. **9** provides for optical aggregation between the multiple sensors to a single detector **104** and emitter **102** and the multiple sensor points. Separate fibers may be used for the emitter path and the sensor path. FIG. **10** shows that alternately a single fiber/wave guide may be used from each sensor point and a suitable optical splitter **87** used to isolate the electronic emitter and detector/sensor paths.

[0057] With reference now to FIGS. **11a-11d**, exemplary embodiments are shown in which an electronic strap **110** is installed in various types of headwear, such as a cap **112**, visor **114**, a headband assembly **116**, and a helmet **118**. In the

helmet-lining embodiment **118**, a properly fit helmet will ensure proper tension of the electronic strap to the head. Additionally, in one area of a headband version, a strap, with an adjustable end, such as Velcro or other means, is placed on the exterior surface of the headband. This may allow for adjustment to the tension of the headband on the head of the user and will allow for fitting to a smaller head size. Maintaining proper tension of the headband on the head avoids measurement inaccuracies, such as venous pulsation interference with inadequate tension or compromised blood flow with excess tension.

[0058] With reference now to FIG. **12**, a blood pressure monitor **90** is disposed in a headwear assembly (e.g., **10, 44**) in accordance with the present invention. The blood pressure monitor includes a pressurized bladder **92** disposed over a blood vessel of the user. Preferably, a blood vessel is near the surface of the user's skin, such as blood vessels in the temporal region of the scalp, such as the superficial temporal artery. A proximity sensor **94** is coupled to the bladder. In this arrangement, the volumetric change of the vessel is transferred to the bladder such that this volumetric change can be sensed by the sensor. Additionally, the bladder may be inflated and deflated using a small air pump **96** and bleed off valve.

[0059] Examples of effective sensors **94** include capacitive proximity sensors, e.g., which can translate displacement to an analog of the capacitance such as a voltage or digital count. Another example is a resistive band around the bladder, e.g., to translate circumference to resistance in a proportional manner. A pressure sensor can be attached to the bladder to measure pressure changes therein. An air pump **96** can be used to restrict the blood flow, periodically, to measure blood pressure, in a sphygmomanometer-type configuration.

[0060] Blood pressure monitor **90** can be located over a temporal region of the scalp or other area. Blood pressure sensor can include proximity sensors combined with small bladders to record volume displacement or capacitance sensors or stretch transducers to record displacement by way of voltage or resistance measurements, to measure the blood pressure of the user. The blood pressure monitor can be mounted on the substrate of the electronic strap (e.g., **60, 12, 14**) and electronically coupled to the circuit board by a flex-wire or other means. Multiple blood pressure monitors can be disposed strategically about the headwear assembly, to improve reliability by obtaining the strongest and most accurate reading from multiple measurements.

[0061] It should be appreciated from the foregoing that the present invention provides an exercise or athletic headwear assembly that measures physiological changes of a user during physical exercise, athletic activities, or other situations including medical monitoring through the use of sensors. Through the natural placement of a variety of headwear embodiments, the sensors will be placed in the preferred location on a user's head. The sensors measure the oxygen saturation, blood pressure, and pulse rate of a user. A thermistor can also be included to measure body temperature. The headwear assembly is capable of presenting data to the user through audio means as well as wireless transmission to other devices, such as a smart phone, where it can be presented to the user by display or audio means on the device itself or through a wired or wireless listening device.

[0062] Although the invention has been disclosed in detail with reference only to the exemplary embodiments, those skilled in the art will appreciate that various other embodi-

ments can be provided without departing from the scope of the invention. Accordingly, the invention is defined by the claims set forth below.

What is claimed is:

1. A headwear assembly, comprising:
 - a headwear body having front portion disposed proximate to the forehead when worn;
 - an oximetry sensor having an emitter and a detector disposed in the front portion; and
 - a circuit board assembly disposed in the headwear body electrically coupled to the oximetry sensor, the oximetry sensor and the circuit board assembly are configured to measure oxygen saturation and pulse rate of the user.
2. The headwear assembly as defined in claim 1, wherein the headwear body provides an aperture in the front portion and the oximetry sensor is aligned with the aperture proximate to the forehead.
3. The headwear assembly as defined in claim 1, the oximetry sensor is mounted on a substrate of a flexible, water proof material.
4. The headwear assembly as defined in claim 1, further comprising a thermistor mounted adjacent to the oximetry sensor and electrically coupled to the circuit board.
5. The headwear assembly as defined in claim 1, wherein the circuit board assembly includes an LED driver electrically coupled to the emitter and a detector circuit operatively coupled to the detector, both the LED driver circuit and detector circuit are operatively coupled to the processor, and the circuit board assembly further includes wireless transceiver operatively coupled to the processor.
6. The headwear assembly as defined in claim 1, wherein the circuit board assembly includes a control button accessible along a side of the headwear body, the control button coupled to the processor.
7. The headwear assembly as defined in claim 1, wherein the headwear body is coupled to a sports helmet such that the headwear body is disposed about the head of a user such that the front portion is proximate to the forehead.
8. The headwear assembly as defined in claim 1, wherein the circuit board assembly is integrally formed with the substrate of the oximetry sensor.
9. A headwear assembly, comprising:
 - a headband configured to circumscribe the head of a user when worn, the headband having front portion disposed proximate to the forehead when worn;
 - an oximetry sensor having a flexible, waterproof substrate, an emitter mounted to the substrate proximate to a distal end of the substrate, and a detector mounted to the substrate proximate to a proximal end of the substrate, the oximetry sensor disposed in the front portion of the headband such that the oximetry sensor is proximate to forehead of a user, when worn; and
 - a circuit board assembly disposed in the headwear body spaced apart from and electrically coupled to the oximetry sensor, the oximetry sensor and the circuit board assembly are configured to measure oxygen saturation and pulse rate of the user.
10. The headwear assembly as defined in claim 9, further comprising a thermistor mounted on the substrate of the oximetry sensor and electrically coupled to the circuit board, to measure body temperature.
11. The headwear assembly as defined in claim 9, wherein the headband is coupled to a cap or a visor such that the headband is disposed about the head of a user such that the front portion is proximate to the forehead.
12. The headwear assembly as defined in claim 9, wherein the headband is coupled to a sports helmet lining such that the headband is disposed about the head of a user such that the front portion is proximate to the forehead.
13. The headwear assembly as defined in claim 9, wherein the circuit board assembly is integrally formed with the substrate of the oximetry sensor.
14. The headwear assembly as defined in claim 9, comprising a plurality of sensors for oximetry and/or for blood pressure disposed in spaced relationship in prescribed locations to measure various selected locations on the user, when worn.
15. A headwear assembly, comprising:
 - a headband configured to circumscribe the head of a user when worn, the headband defining an aperture disposed proximate to the forehead when worn;
 - an oximetry sensor having a waterproof substrate, an emitter and a detector mounted to the substrate, the oximetry sensor aligned with the aperture of the headband such that the oximetry sensor is disposed above an eyebrow of a user, when worn;
 - a thermistor mounted to the substrate of the oximetry sensor;
 - a circuit board assembly disposed in the headwear body spaced apart from and electrically coupled to the oximetry sensor, the oximetry sensor and the circuit board assembly are configured to measure oxygen saturation and pulse rate of the user, the thermistor and a blood pressure sensor are electrically coupled to the circuit board to measure body temperature and blood pressure, the circuit board having a waterproof casing.
16. The headwear assembly as defined in claim 15, wherein the circuit board assembly includes a control button accessible along a side of the headwear body, the control button coupled to the processor.
17. The headwear assembly as defined in claim 15, wherein the circuit board assembly includes an LED driver electrically coupled to the emitter and a detector circuit electrically coupled to the detector, both the LED driver circuit and detector circuit are electrically coupled to the processor, and the circuit board assembly further includes wireless transceiver electrically coupled to the processor configured to communicate with an external electronic mobile device.
18. The headwear assembly as defined in claim 15, comprising a plurality of sensors for oximetry and/or for blood pressure disposed in spaced relationship in prescribed locations to measure various selected locations on the user, when worn, the headband defining a plurality of apertures aligned with the plurality of sensors.
19. The headwear assembly as defined in claim 18, wherein the plurality of sensors include a plurality of sensing ends operatively coupled to the emitter and the detector, the plurality of sensing ends aligned with the plurality of apertures to measure the forehead of the user.
20. The headwear assembly as defined in claim 19, wherein the plurality of sensing ends are operatively coupled to the emitter and the detector by single or dual light-wave channels.

专利名称(译)	电子头饰		
公开(公告)号	US20140296669A1	公开(公告)日	2014-10-02
申请号	US13/853526	申请日	2013-03-29
[标]申请(专利权)人(译)	TRI MATE PRO		
[标]发明人	GERTSCH BRUCE GERTSCH RONALD NYSEN PAUL NYSEN PETER SWANSON WILLIAM GEHRISCH CHRISTOPHER L MCCUNE MARTIN D WILLIAMS DAVID L		
发明人	GERTSCH, BRUCE GERTSCH, RONALD NYSEN, PAUL NYSEN, PETER SWANSON, WILLIAM GEHRISCH, CHRISTOPHER L. MCCUNE, MARTIN D. WILLIAMS, DAVID L.		
IPC分类号	A61B5/00 A61B5/0205 A61B5/01 A61B5/1455		
CPC分类号	A61B5/6803 A61B5/14552 A61B5/02427 A61B5/01 A61B5/0008 A61B5/02055		
其他公开文献	US10265019		
外部链接	Espacenet USPTO		

摘要(译)

提供一种头饰组件，其测量在体育锻炼期间用户的生理变化，例如氧饱和度，脉搏，血压和体温，以包括运动活动和其他情况。头饰组件可以提供与诸如智能电话的外部设备的集成功能。头饰组件可以以各种配置实施，例如独立头带，帽，遮阳板或头盔。

