



US009794668B2

(12) **United States Patent**  
**Masaki et al.**

(10) **Patent No.:** **US 9,794,668 B2**  
(45) **Date of Patent:** **\*Oct. 17, 2017**

(54) **SMART FLEXIBLE INTERACTIVE EARPLUG**

*G10L 25/51* (2013.01); *H04M 1/6058* (2013.01); *H04R 1/028* (2013.01); *H04R 1/04* (2013.01); *H04R 1/1041* (2013.01);  
(Continued)

(71) Applicant: **SmartEar, Inc.**, San Francisco, CA (US)

(58) **Field of Classification Search**  
CPC ..... H04R 1/105; H04R 2430/01; G10L 2021/065; H04M 3/5696  
See application file for complete search history.

(72) Inventors: **Kinuko Masaki**, San Francisco, CA (US); **Dean Gardner**, San Francisco, CA (US); **Victor Valenzuela**, Hayward, CA (US)

(56) **References Cited**

(73) Assignee: **SmartEar, Inc.**, San Francisco, CA (US)

U.S. PATENT DOCUMENTS

(\* ) Notice: Subject to any disclaimer, the term of this patent is extended or adjusted under 35 U.S.C. 154(b) by 0 days.

1,852,130 A 4/1932 Schier  
1,893,143 A 1/1933 Henry  
(Continued)

This patent is subject to a terminal disclaimer.

FOREIGN PATENT DOCUMENTS

WO WO2014/138735 A1 9/2014

(21) Appl. No.: **15/413,338**

OTHER PUBLICATIONS

(22) Filed: **Jan. 23, 2017**

International Search Report for PCT/US15/57998 and International Written Opinion for PCT/US15/57988, dated Apr. 29, 2016, 15 pages.

(65) **Prior Publication Data**

US 2017/0238081 A1 Aug. 17, 2017

(Continued)

**Related U.S. Application Data**

*Primary Examiner* — Bobbak Safaipoor

(63) Continuation of application No. 14/926,076, filed on Oct. 29, 2015, now Pat. No. 9,571,913.

(74) *Attorney, Agent, or Firm* — Avancept LLC; Thomas L. Ewing

(Continued)

(57) **ABSTRACT**

(51) **Int. Cl.**  
*H04R 1/10* (2006.01)  
*H04R 1/04* (2006.01)  
(Continued)

An embodiment of the invention provides a resiliently deformable and flexible in-ear sound device having stretchable electronic circuitry. The in-ear sound device may be configured in a variety of ways, including, but in no way limited to a smart earplug, a flexible personal sound amplification product, a personal music player, a “walkie-talkie” and the like.

(52) **U.S. Cl.**  
CPC ..... *H04R 1/1016* (2013.01); *A61B 5/02055* (2013.01); *A61B 5/14551* (2013.01); *A61B 5/6817* (2013.01); *G10L 17/22* (2013.01);

**40 Claims, 10 Drawing Sheets**

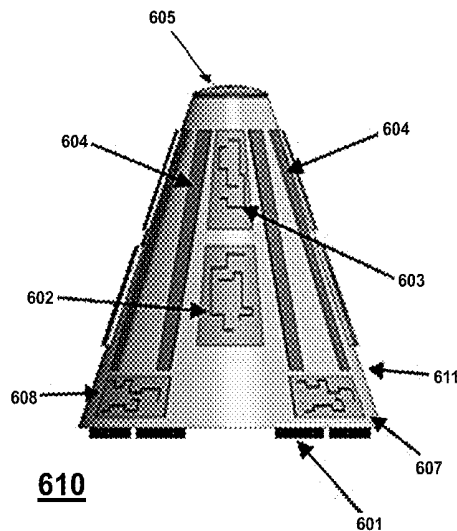

Related U.S. Application Data

(60) Provisional application No. 62/072,776, filed on Oct. 30, 2014.

(51) Int. Cl.

- H04W 4/00* (2009.01)
- H04R 1/02* (2006.01)
- H04R 25/00* (2006.01)
- H04M 1/60* (2006.01)
- G10L 17/22* (2013.01)
- G10L 25/51* (2013.01)
- A61B 5/00* (2006.01)
- A61B 5/0205* (2006.01)
- A61B 5/1455* (2006.01)
- A61B 5/024* (2006.01)
- A61B 5/08* (2006.01)
- A61B 5/021* (2006.01)
- A61B 5/0476* (2006.01)
- A61B 5/0402* (2006.01)
- A61B 5/11* (2006.01)
- A61B 5/053* (2006.01)

(52) U.S. Cl.

- CPC ..... *H04R 1/1058* (2013.01); *H04R 1/1083* (2013.01); *H04R 25/652* (2013.01); *A61B 5/021* (2013.01); *A61B 5/024* (2013.01); *A61B 5/02405* (2013.01); *A61B 5/0402* (2013.01); *A61B 5/0476* (2013.01); *A61B 5/0533* (2013.01); *A61B 5/0816* (2013.01); *A61B 5/11* (2013.01); *A61B 2562/0219* (2013.01); *A61B 2562/0223* (2013.01); *H04R 25/505* (2013.01); *H04R 2201/103* (2013.01); *H04R 2201/107* (2013.01); *H04R 2420/07* (2013.01); *H04R 2460/11* (2013.01)

(56) References Cited

U.S. PATENT DOCUMENTS

- 2,248,837 A 7/1941 Walters
- 2,619,960 A 12/1952 Reynolds
- 2,678,973 A 5/1954 Newman
- 2,754,365 A 7/1956 Walters
- 2,971,065 A 2/1961 Busse
- 2,984,726 A 5/1961 Roeser
- 3,282,106 A 11/1966 Bowling
- D207,222 S 3/1967 Geib
- D219,983 S 2/1971 Bosch
- 3,815,583 A 6/1974 Scheidt
- 3,983,336 A 9/1976 Malek
- 4,069,400 A 1/1978 Johanson
- 4,133,984 A 1/1979 Akiyama
- 4,359,708 A 11/1982 Jarosz
- 4,539,708 A 9/1985 Norris
- 4,550,227 A 10/1985 Topholm
- D287,280 S 12/1986 Topholm
- D287,764 S 1/1987 Topholm
- D287,765 S 1/1987 Topholm
- D300,528 S 4/1989 Drane
- 5,159,936 A 11/1992 Yelderman
- 5,167,235 A 12/1992 Seacord
- D335,349 S 5/1993 Lyon
- D374,658 S 10/1996 Bever
- D377,337 S 1/1997 Schaeffer
- 5,626,139 A 5/1997 Szeles
- 5,654,530 A 8/1997 Sauer
- 5,812,680 A 9/1998 Glendon
- D422,749 S 4/2000 Binstock
- D435,580 S 12/2000 Grinkus
- 6,358,281 B1 3/2002 Berrang
- D455,405 S 4/2002 Bonn
- D464,630 S 10/2002 Woodworth

- D469,411 S 1/2003 Oecosse
- D475,996 S 6/2003 Skulley
- D481,709 S 11/2003 Solderits
- 6,648,914 B2 11/2003 Berrang
- D483,281 S 12/2003 Cobigo
- D506,989 S 7/2005 Seil
- D519,985 S 5/2006 Wikel
- D526,990 S 8/2006 Slevin
- D529,175 S 9/2006 Franz
- 7,120,267 B2 10/2006 Ito
- D532,520 S 11/2006 Kampmeier
- D536,692 S 2/2007 Alwicker
- D537,438 S 2/2007 Hermansen
- D555,146 S 11/2007 Sandy
- D568,290 S 5/2008 Wikel
- D589,152 S 3/2009 Champkins
- D596,295 S 7/2009 Hedstrom
- D601,548 S 10/2009 Morisawa
- D603,380 S 11/2009 Hutchieson
- D609,000 S 2/2010 Portney
- D628,565 S 12/2010 Wu
- D632,677 S 2/2011 Brown
- D635,676 S 4/2011 Voix
- D643,833 S 8/2011 Lee
- D655,277 S 3/2012 Wai
- D666,581 S 9/2012 Perez
- 8,275,166 B2 9/2012 Wu
- D670,391 S 11/2012 Goodman
- D673,497 S 1/2013 Rosenzweig
- D674,904 S 1/2013 Aunio
- D678,849 S 3/2013 McCullar
- 8,389,862 B2 3/2013 Arora
- D682,430 S 5/2013 Kasic
- D693,796 S 11/2013 Birger
- D698,026 S 1/2014 Kuwata
- 8,634,918 B2 1/2014 Chambers
- D705,751 S 5/2014 Wenger
- D705,760 S 5/2014 Orambarean
- 8,798,298 B1 \* 8/2014 Burns ..... H04R 1/2876  
264/267
- 8,855,345 B2 10/2014 Shennib
- D717,443 S 11/2014 Hughes
- D719,139 S 12/2014 Henry
- D725,082 S 3/2015 Palmborg
- 8,983,108 B2 3/2015 Ho
- D726,165 S 4/2015 Kawaji
- D726,567 S 4/2015 De Jong
- D733,102 S 6/2015 Palmborg
- 9,078,070 B2 7/2015 Samuels
- D739,851 S 9/2015 Donohue
- D744,110 S 11/2015 Kubo
- D746,792 S 1/2016 Kim
- 9,271,091 B2 2/2016 Zurbrugg
- 9,456,285 B2 9/2016 Bymaster
- D770,426 S 11/2016 LaBerge
- D773,437 S 12/2016 Lee
- D776,281 S 1/2017 Fyrlund
- D777,710 S 1/2017 Palmborg
- 9,571,913 B2 \* 2/2017 Masaki ..... G10L 17/22
- D781,269 S 3/2017 Choe
- 2002/0181336 A1 \* 12/2002 Shields ..... G04G 9/0082  
368/84
- 2003/0027606 A1 2/2003 Tsai
- 2004/0224717 A1 11/2004 Hertzberg
- 2004/0243204 A1 \* 12/2004 Maghribi ..... A61N 1/05  
607/115
- 2006/0045304 A1 3/2006 Lee
- 2006/0098833 A1 5/2006 Juneau
- 2007/0154030 A1 7/2007 Moses
- 2007/0154049 A1 7/2007 Levitsky
- 2008/0063231 A1 \* 3/2008 Juneau ..... H04R 25/456  
381/328
- 2009/0143096 A1 \* 6/2009 Chang ..... H04M 1/6066  
455/556.1
- 2010/0002402 A1 \* 1/2010 Rogers ..... H01L 21/4867  
361/749
- 2011/0002498 A1 1/2011 Wong
- 2011/0224493 A1 \* 9/2011 Oyadiran ..... A61B 1/00016  
600/200

(56)

References Cited

U.S. PATENT DOCUMENTS

2012/0114160 A1 5/2012 Lin  
 2012/0282976 A1 11/2012 Suhami  
 2012/0300965 A1 11/2012 Samuels  
 2012/0308062 A1\* 12/2012 Djalilian ..... H04R 5/00  
 381/318  
 2013/0142363 A1\* 6/2013 Amento ..... H04K 1/00  
 381/151  
 2013/0337796 A1\* 12/2013 Suhami ..... H04R 25/00  
 455/422.1  
 2014/0010378 A1\* 1/2014 Voix ..... H04R 1/1083  
 381/57  
 2014/0112520 A1 4/2014 Knudsen  
 2014/0169599 A1\* 6/2014 Solum ..... H04R 25/554  
 381/315  
 2014/0172042 A1\* 6/2014 Goorevich ..... H04R 25/505  
 607/57  
 2014/0241551 A1\* 8/2014 Kim ..... H04R 3/12  
 381/306  
 2014/0301561 A1\* 10/2014 Silberman ..... H04R 1/1091  
 381/74  
 2014/0303452 A1\* 10/2014 Ghaffari ..... A61B 1/05  
 600/301  
 2015/0183167 A1 7/2015 Molinari  
 2015/0230022 A1 8/2015 Sakai  
 2015/0256941 A1 9/2015 Bymaster

2015/0257683 A1\* 9/2015 Ashmore ..... A61B 5/0022  
 600/559  
 2015/0261298 A1 9/2015 Li  
 2015/0382096 A1\* 12/2015 Lamar ..... H04R 1/1041  
 381/74  
 2016/0049074 A1 2/2016 Shennib  
 2016/0057550 A1 2/2016 Shennib  
 2016/0162256 A1 6/2016 Komaromi  
 2016/0192050 A1 6/2016 Masaki  
 2016/0206000 A1 7/2016 Lord

OTHER PUBLICATIONS

International Search Report for PCT/US15/57998, and International  
 Written Opinion for PCT/US15/57988, dated Apr. 29, 2016, 15  
 pages.  
 “Wireless Headphones | Koss Striva Tap Wi-Fi Earbuds” by Mila  
 Pantovich Jun. 8, 2012, JustLuxe, pp. 1-3, [http://www.justluxe.com/  
 lifestyle/electronics/feature-1780526.php](http://www.justluxe.com/lifestyle/electronics/feature-1780526.php) (retrieved Apr. 16, 2017).  
 “Here Active Listening earbuds: Augmented reality for your ears  
 (hands-on)” by Will Shanklin, Jan. 13, 2016, pp. 1-4, [http://  
 newatlas.com/doppler-labs-here-earbuds-hands-on/41322/](http://newatlas.com/doppler-labs-here-earbuds-hands-on/41322/)  
 (retrieved Apr. 16, 2017).  
 Nap Zapper Anti-Sleep Alarm, Amazon, pp. 1-6, [https://www.  
 amazon.com/Generic-Nap-Zapper-Anti-Sleep-Alarm/dp/  
 B000BK4KW8](https://www.amazon.com/Generic-Nap-Zapper-Anti-Sleep-Alarm/dp/B000BK4KW8) (retrieved Apr. 16, 2017).

\* cited by examiner

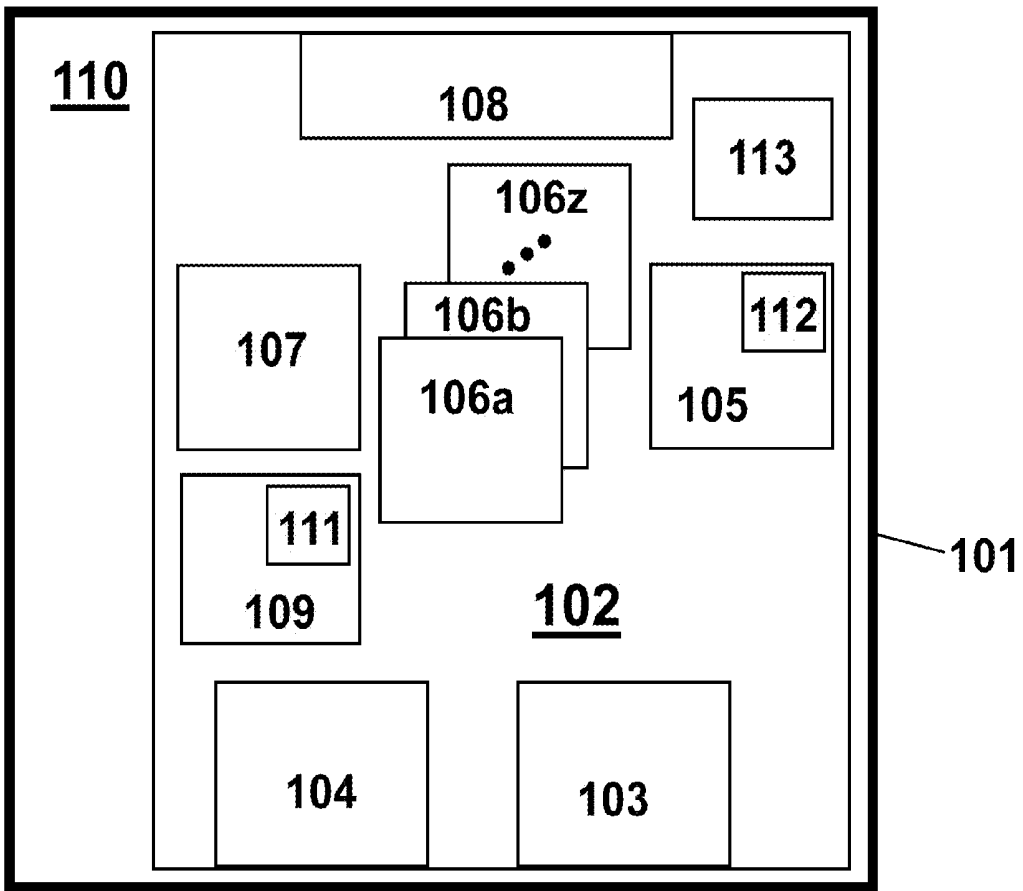

FIG. 1

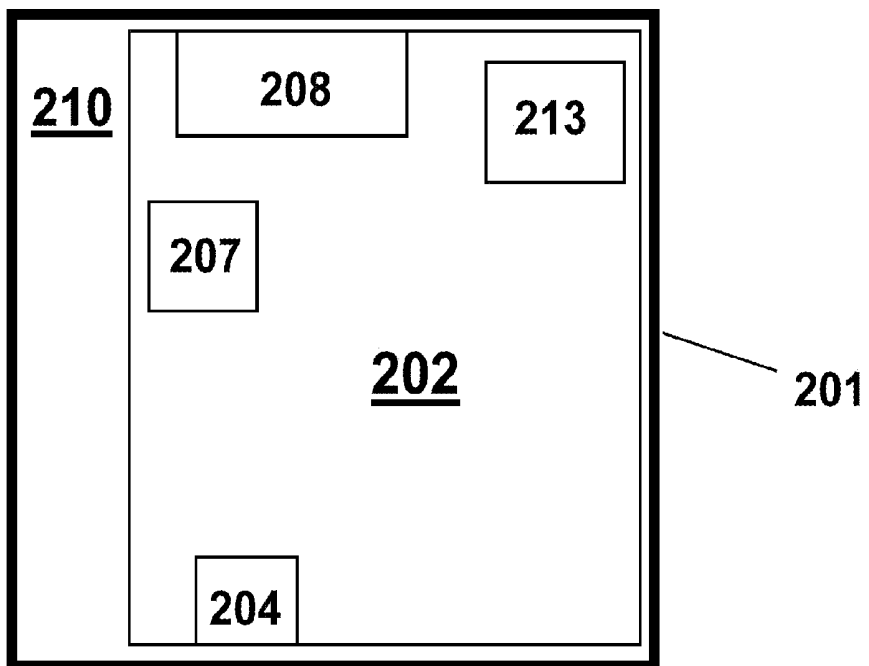

FIG. 2

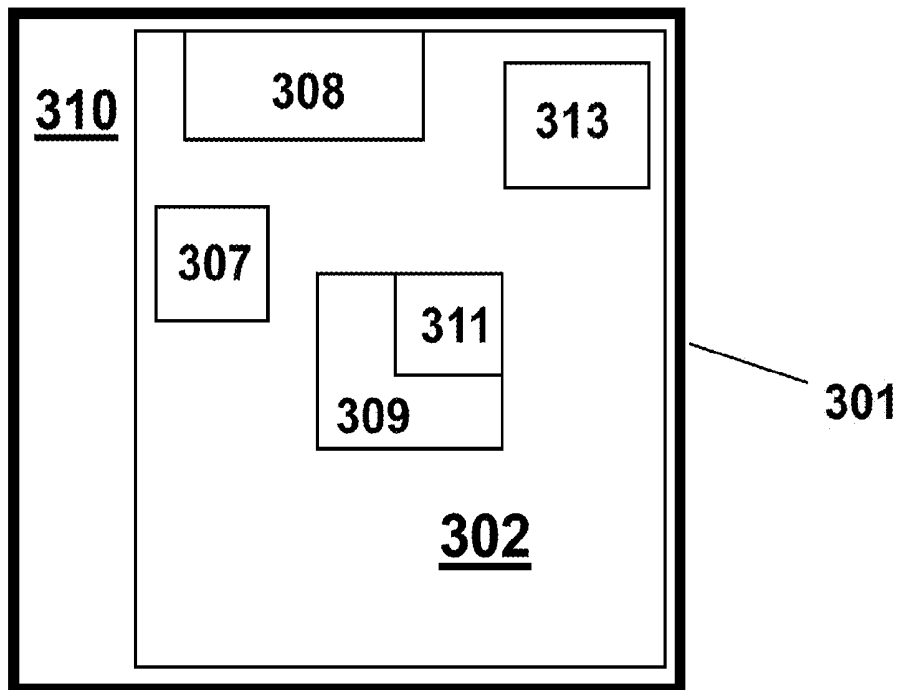

FIG. 3

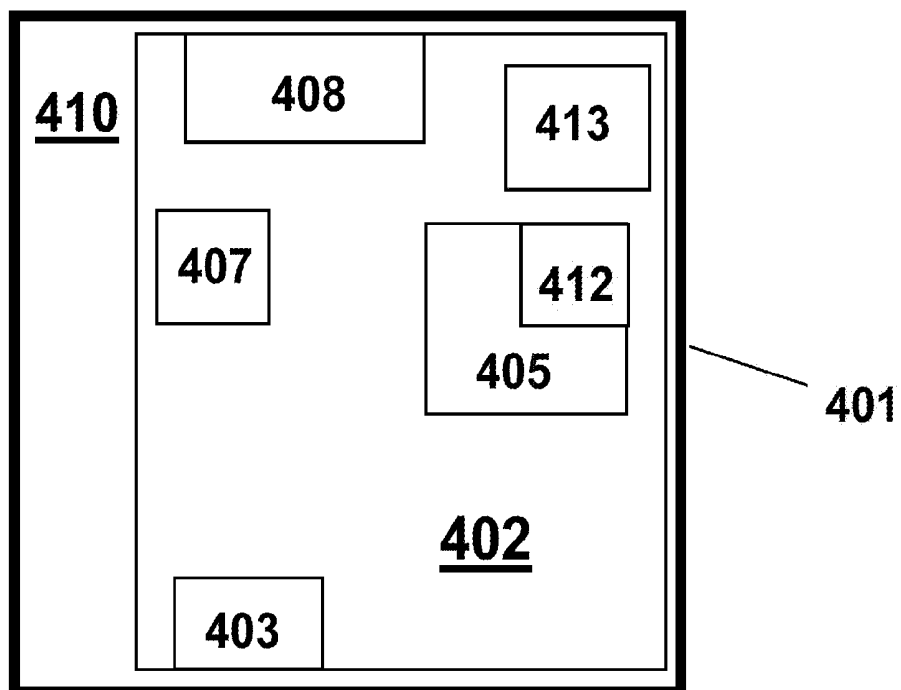
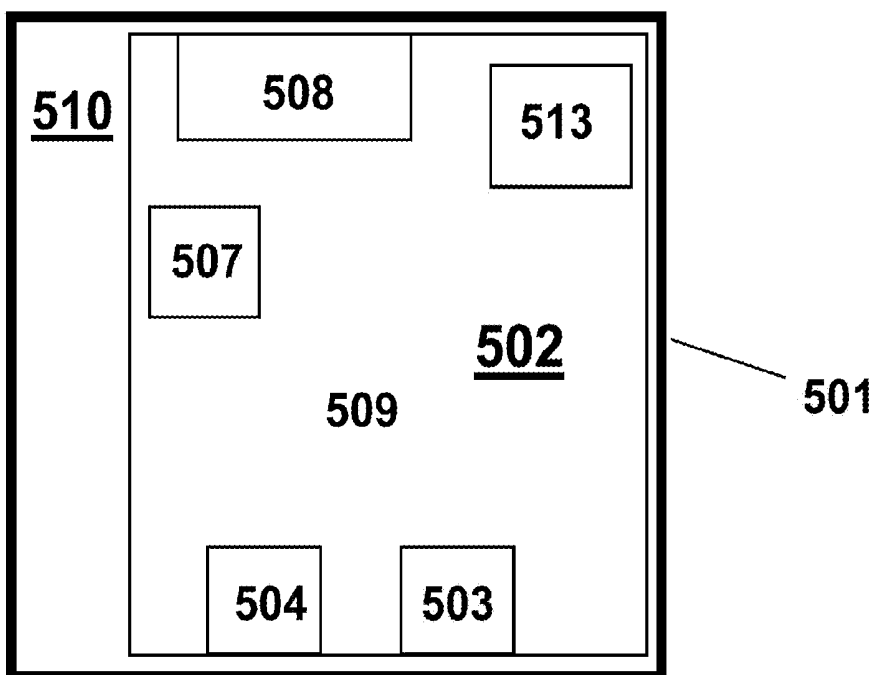
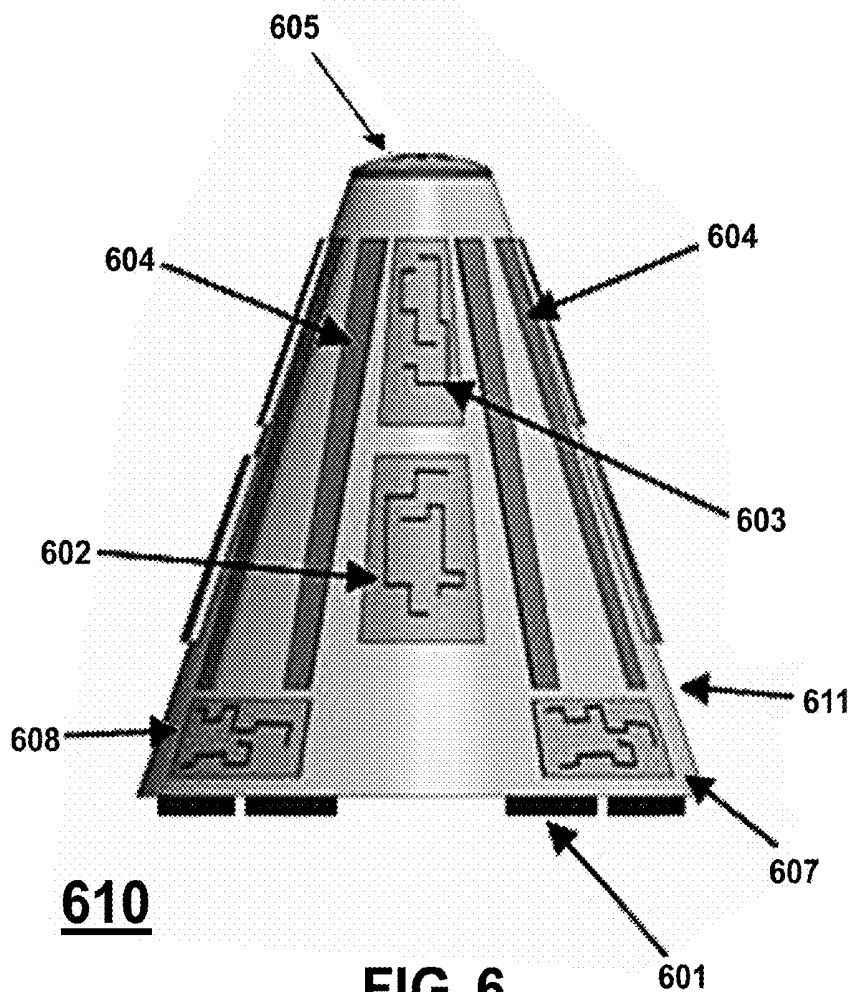

FIG. 4



**FIG. 5**



**FIG. 6**

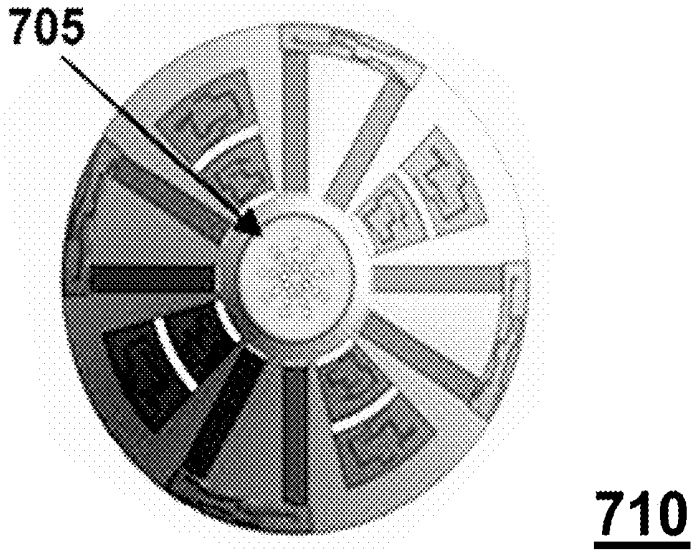

FIG. 7

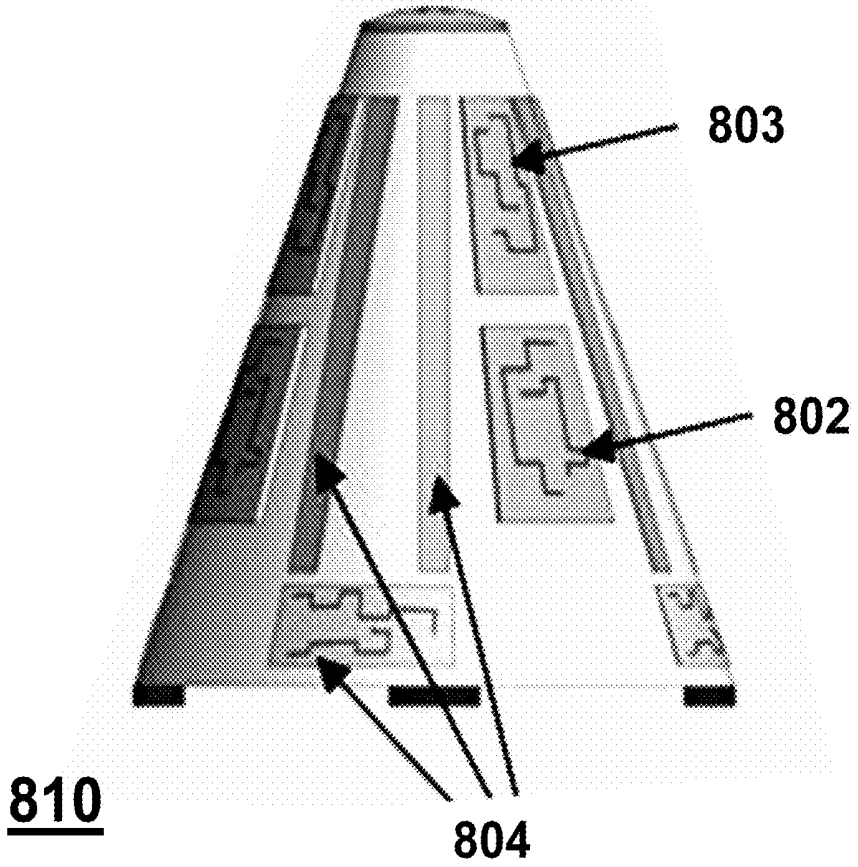

FIG. 8

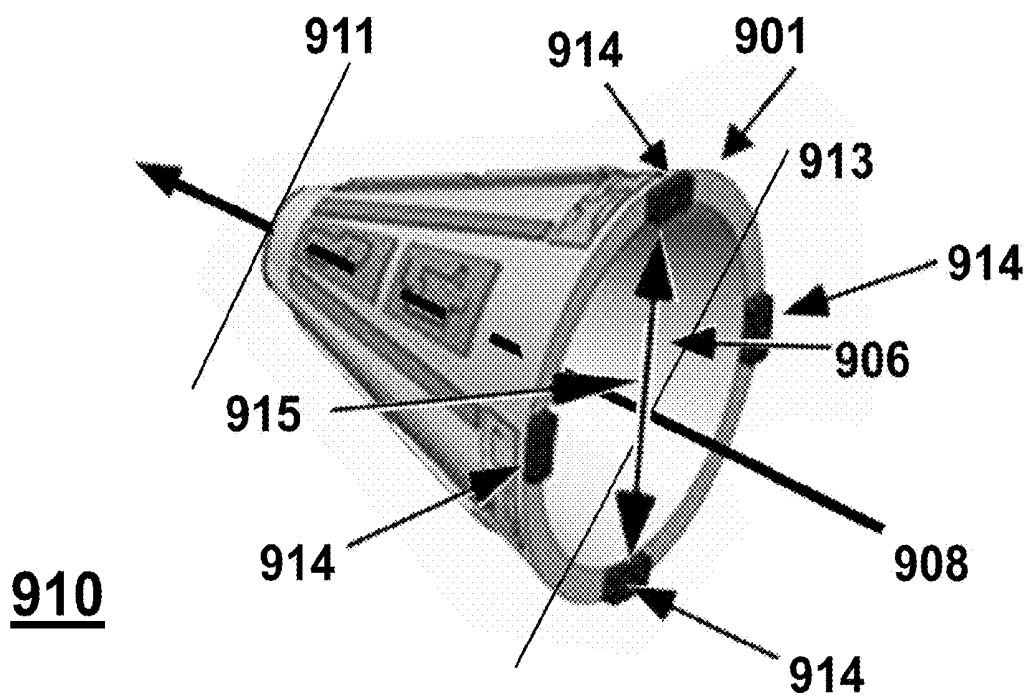

FIG. 9

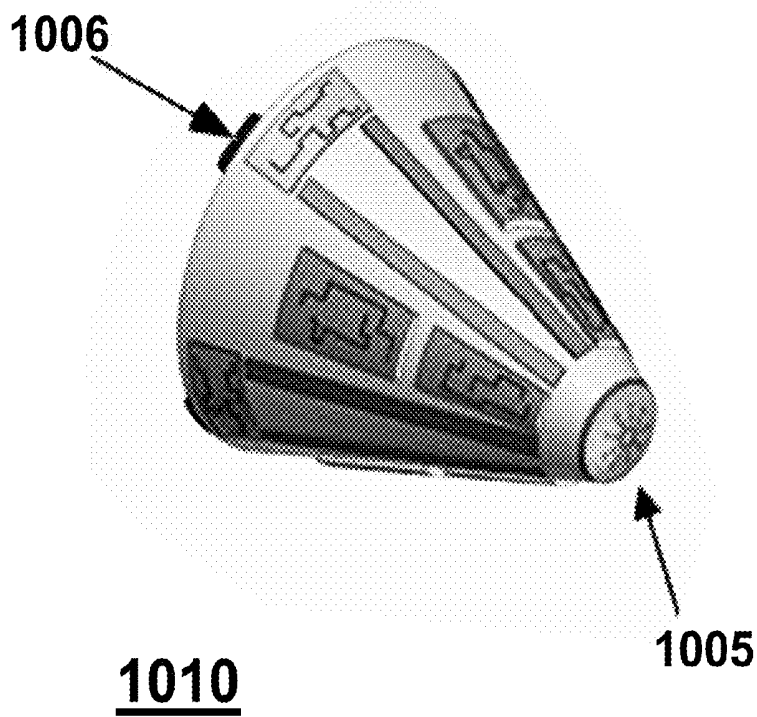

FIG. 10

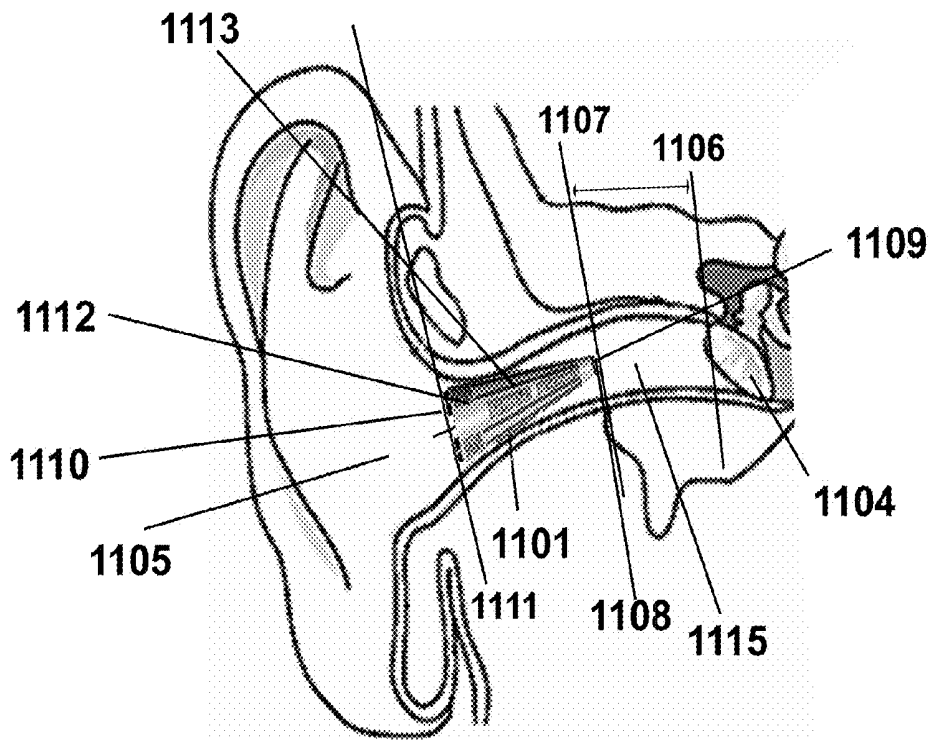

FIG. 11

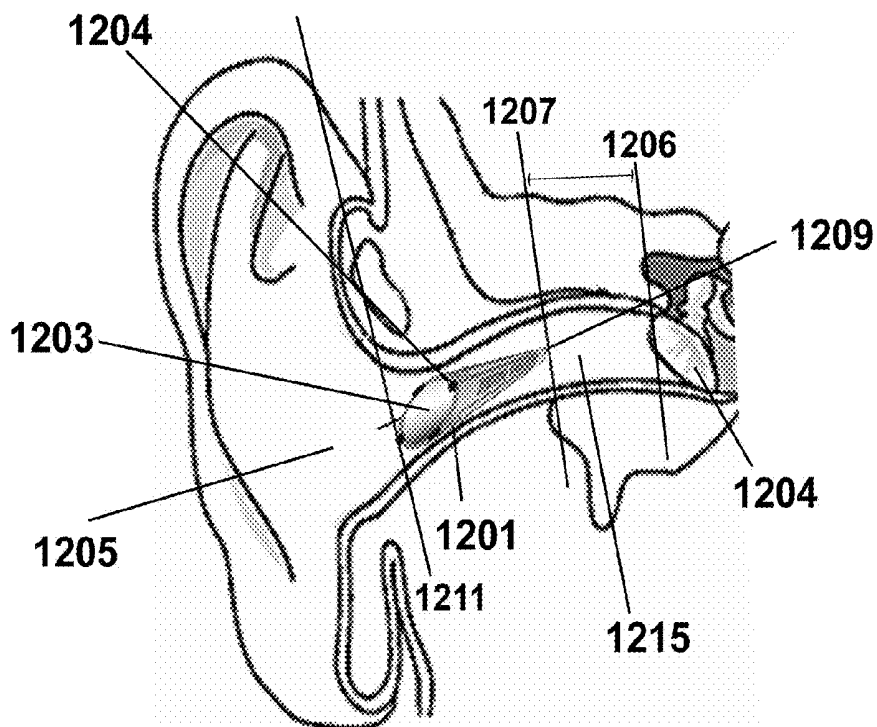
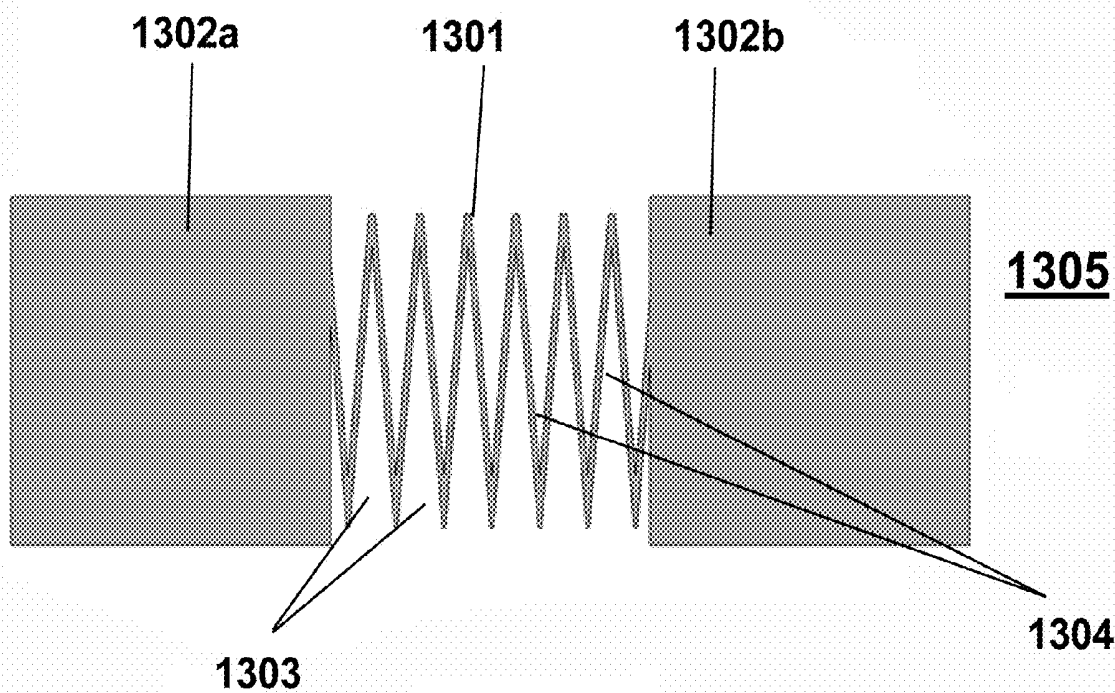
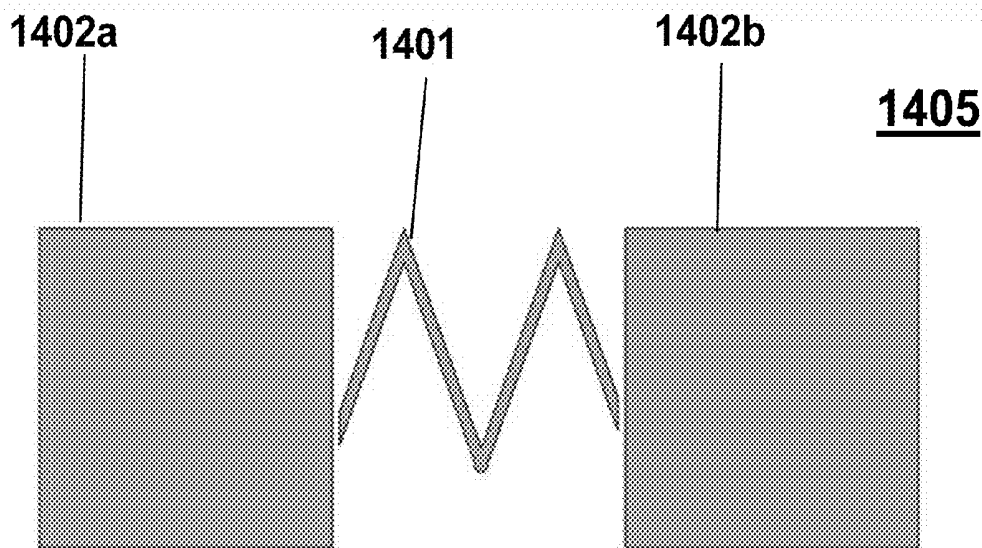

FIG. 12



**FIG. 13**



**FIG. 14**

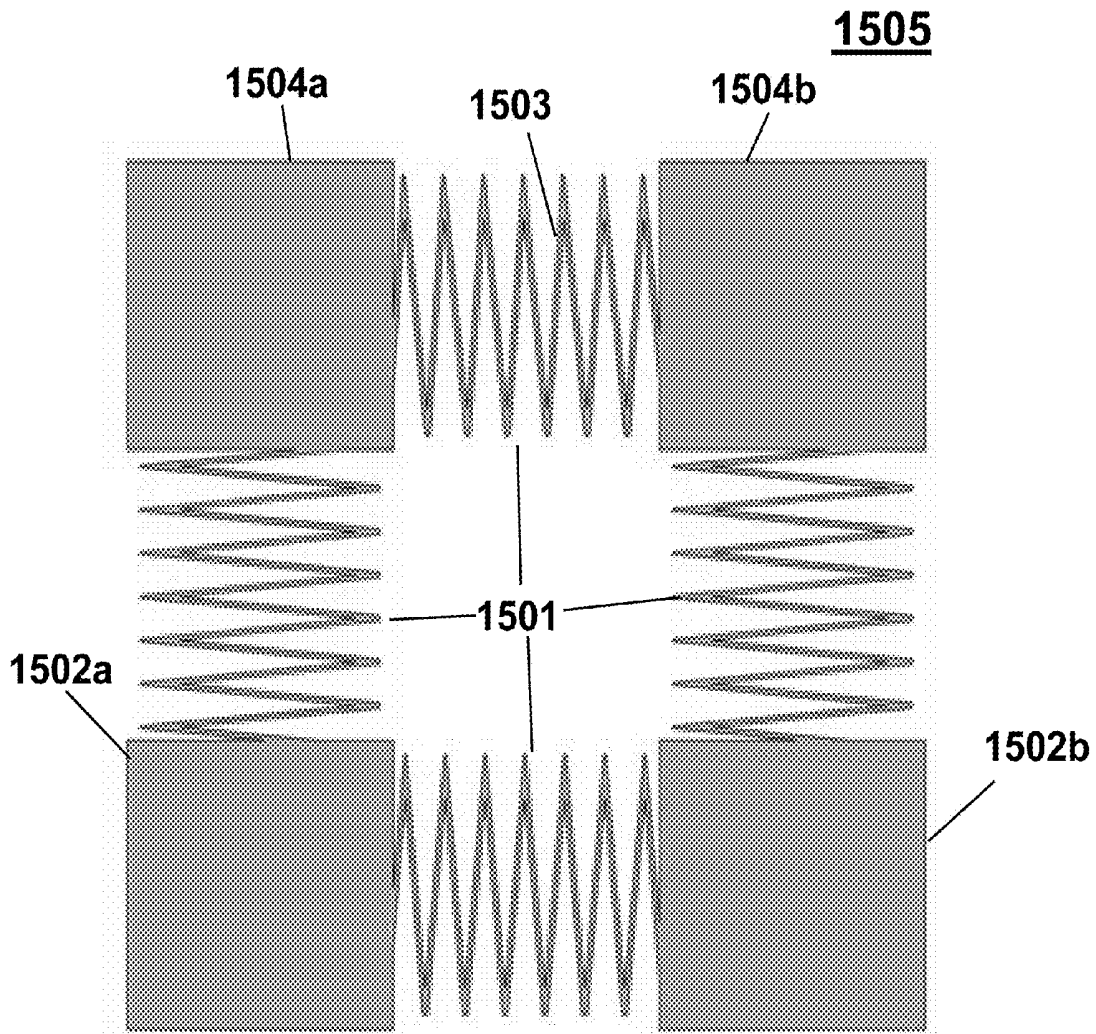

FIG. 15

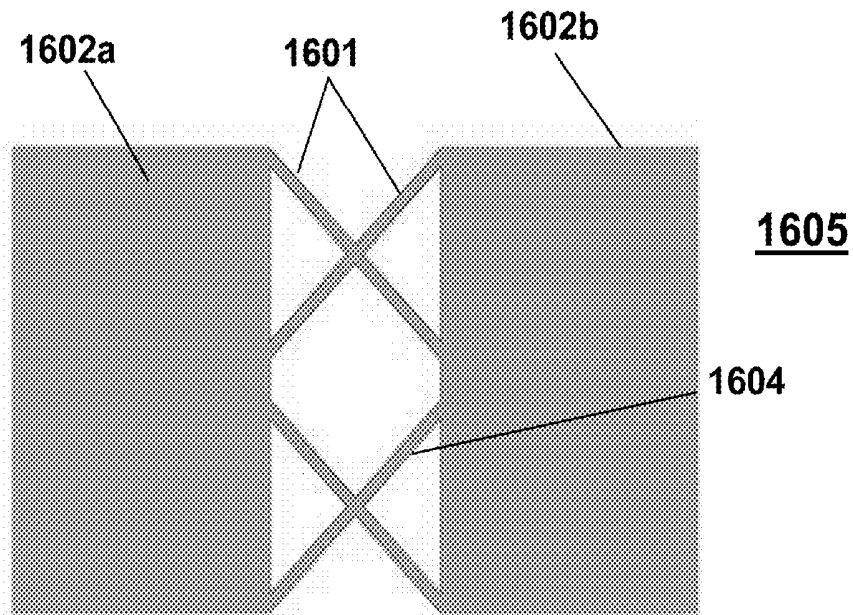

FIG. 16

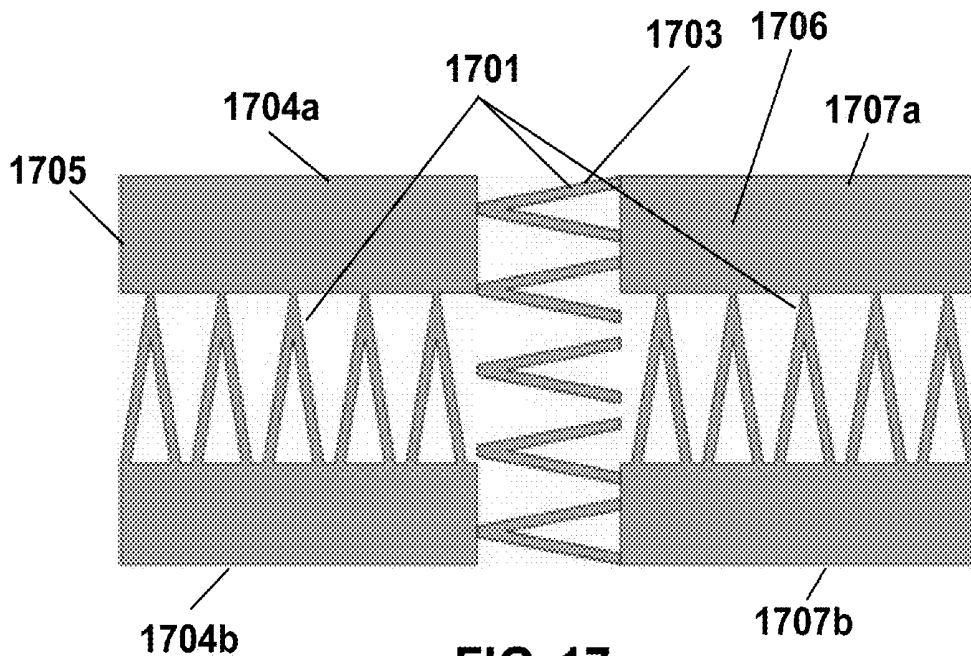

FIG. 17

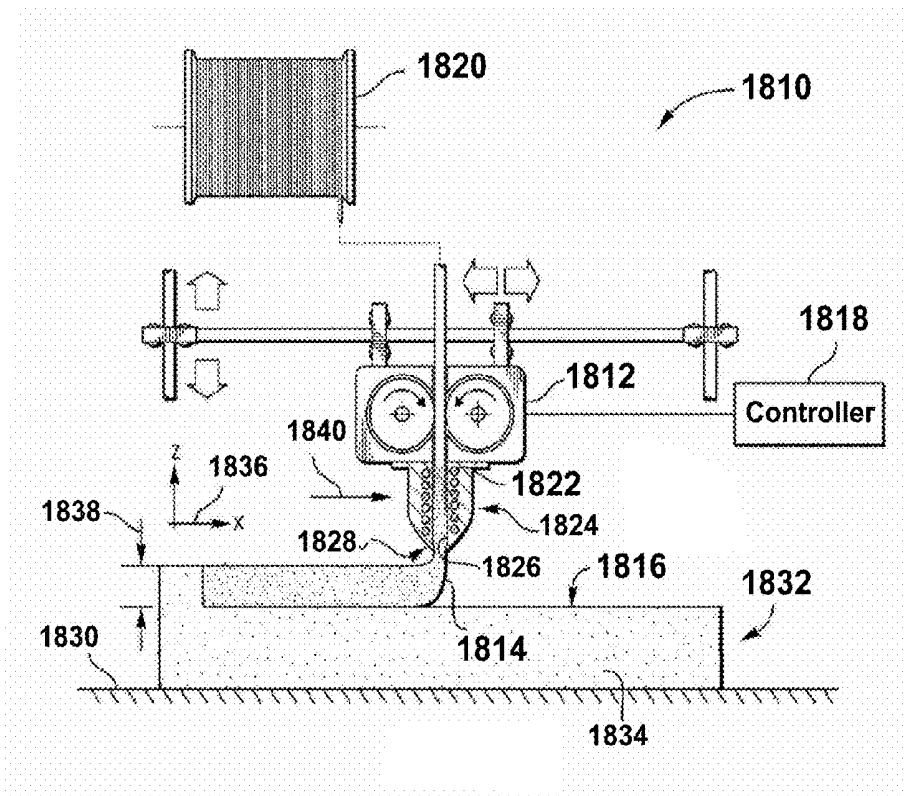

FIG. 18

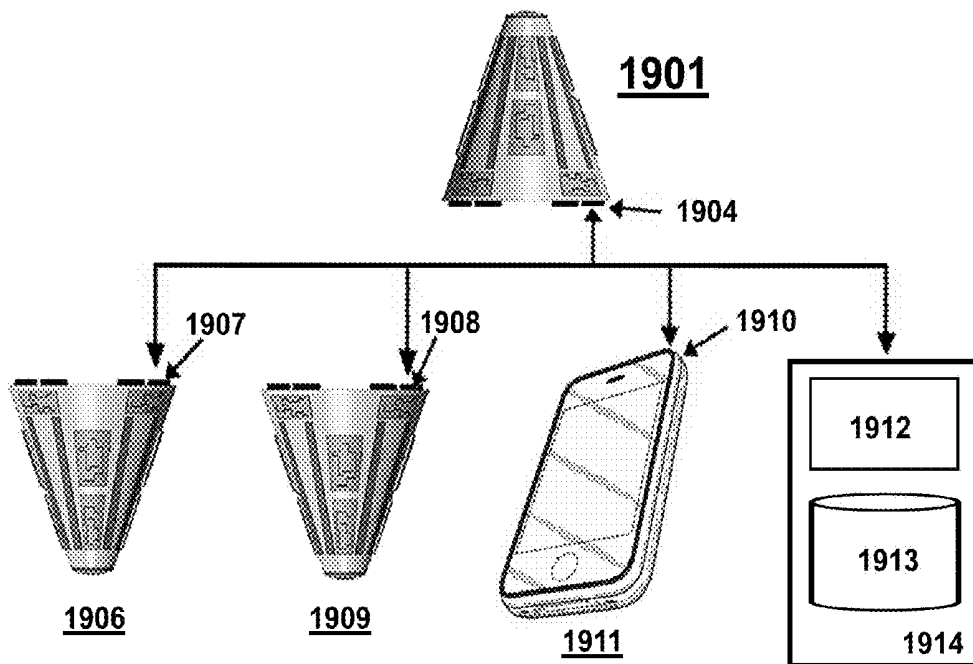

FIG. 19

**1**  
**SMART FLEXIBLE INTERACTIVE**  
**EARPLUG**

FIELD

Embodiments of the invention relate to systems and methods providing in-ear sound devices. More particularly, an embodiment of the invention relates to systems and methods that use flexible electronics to provide an improved in-ear sound device.

BACKGROUND

The following description includes information that may be useful in understanding embodiments of the invention. It is not an admission that any of the information provided herein is prior art or relevant to the presently claimed invention, or that any publication specifically or implicitly referenced is prior art.

With the development of portable multimedia devices and smart phones, many types of earphones and headsets have been developed and used. However, previous devices have traditionally been bulky and uncomfortable as well as being limited in their technological abilities.

Therefore, a need exists for more advanced sound devices that can perform an expanded set of tasks at an improved rate of performance over the devices found in the prior art.

SUMMARY OF THE INVENTION

Embodiments of the invention comprise a deformable and flexible in-ear sound device. The in-ear sound device comprises a deformable and flexible body having a longitudinal axis extending between a distal end and a proximal end. The in-ear sound device further comprises an electronic component package comprising stretchable electronic circuitry. The electronic component package includes a speaker located at the proximal end of the deformable and flexible body, wherein the stretchable electronic circuitry is at least one of embedded in or on the deformable and flexible body. In some embodiments of the invention, the deformable and flexible body include a canal that can be opened and closed.

Embodiments of the invention further comprise a method for outputting sound to a user's ear in a deformable and flexible in-ear sound device. The method comprises placing an electronic component package comprising stretchable electronic circuitry on a deformable and flexible body having a longitudinal axis extending between a distal end and a proximal end. The stretchable electronic circuitry resides on the deformable and flexible body by at least one of embedding the electronic component package in or on the deformable and flexible body. The method further comprises placing a speaker at the proximal end of the deformable and flexible body.

BRIEF DESCRIPTION OF THE DRAWINGS

Figures provided herein may or may not be provided to scale. The relative dimensions or proportions may vary. Embodiments of the invention may be sized to fit within an ear canal of a user.

FIG. 1 provides a block diagram that illustrates an in-ear sound device **101**, according to an embodiment of the invention.

FIG. 2 illustrates an embodiment of an in-ear sound device **201** configured to function as a headphone, according to an embodiment of the invention.

**2**

FIG. 3 illustrates an embodiment of an in-ear sound device **301** configured to function as a music player, according to an embodiment of the invention.

FIG. 4 illustrates an embodiment of an in-ear sound device **401** configured to provide hearing amplification, according to an embodiment of the invention.

FIG. 5 illustrates an embodiment of an in-ear sound device **501** configured to provide a walkie-talkie function (a portable, two-way radio transceiver), according to an embodiment of the invention.

FIG. 6 illustrates an embodiment of an in-ear sound device **610** that employs stretchable circuitry in the electronic component package **611** of the in-ear sound device **610**.

FIG. 7 illustrates an in-ear sound device **710**, according to an embodiment of the invention.

FIG. 8 illustrates an in-ear sound device **810**, according to an embodiment of the invention.

FIG. 9 illustrates an in-ear sound device **910** having a hole or canal **906** running along its longitudinal axis **908**, according to an embodiment of the invention.

FIG. 10 illustrates an in-ear sound device **1010** having a microphone **1005** at its proximal tip and at least one clamp **1006** for closing a canal (e.g., the canal **906** shown in FIG. 9) in the in-ear sound device **1010**, according to an embodiment of the invention.

FIG. 11 illustrates an in-ear sound device **1101** inserted into an ear **1105**, according to an embodiment of the invention.

FIG. 12 illustrates an in-ear sound device **1201** inserted into an ear **1205**, according to an embodiment of the invention.

FIG. 13 illustrates an embodiment of the invention that employs stretchable electronics formed on discrete islands **1302a**, **1302b** of silicon, according to an embodiment of the invention.

FIG. 14 illustrates an alternative embodiment of the invention that employs stretchable electronics formed on discrete islands **1402a**, **1402b** of silicon, according to an embodiment of the invention.

FIG. 15 illustrates an electronics package **1505** comprising discrete islands **1502a**, **1502b**, **1504a**, and **1504b** bound together using zigzag interconnects **1501**, according to an embodiment of the invention.

FIG. 16 illustrates an embodiment of the invention that employs a stretchable electronic package **1605** in which the electronics have been formed on discrete islands **1602a**, **1602b** of silicon bound together using interconnects **1601** having a crisscross or X-pattern **1604**, according to an embodiment of the invention.

FIG. 17 illustrates an electronics package **1705** bound to another stretchable electronics package **1706** using zigzag interconnects **1703**, according to an embodiment of the invention.

FIG. 18 illustrates a three-dimensional (3D) printer **1810** that may form an in-ear sound device **1832**, according to an embodiment of the invention.

FIG. 19 illustrates an in-ear sound device **1901** communicating wirelessly with other devices **1906**, **1909**, **1911**, and **1914**, according to an embodiment of the invention.

DETAILED DESCRIPTION OF AN  
EMBODIMENT OF THE INVENTION

Various embodiments of the invention will be described in detail with reference to the accompanying drawings. References made to particular examples and implementations are

for illustrative purposes, and are not intended to limit the scope of the invention or the claims.

It should be noted that while many embodiments of the invention described herein are drawn to a smart earplug, various configurations are deemed suitable and may employ various computing devices including servers, interfaces, systems, databases, agents, engines, controllers, or other types of computing devices operating individually or collectively. One should appreciate that any referenced computing devices comprise a processor configured to execute software instructions stored on a tangible, non-transitory computer readable storage medium (e.g., hard drive, solid state drive, RAM, flash, ROM, etc.). The software instructions preferably configure the computing device to provide the roles, responsibilities, or other functionality as discussed below with respect to the disclosed smart earplug.

The following discussion provides many example embodiments of the claimed subject matter. Although each embodiment represents a single combination of elements, the inventive subject matter is considered to include all possible combinations of the disclosed elements. Thus, if one embodiment comprises elements A, B, and C, and a second embodiment comprises elements B and D, then the inventive subject matter is also considered to include other remaining combinations of A, B, C or D, even if not explicitly disclosed.

All publications herein are incorporated by reference to the same extent as if each individual publication or patent application were specifically and individually indicated to be incorporated by reference. Where a definition or use of a term in an incorporated reference is inconsistent or contrary to the definition of that term provided herein, the definition of that term provided herein applies and the definition of that term in the reference does not apply.

As used in the description herein and throughout the claims that follow, the meaning of “a,” “an,” and “the” includes plural reference unless the context clearly dictates otherwise. Also, as used in the description herein, the meaning of “in” includes “in” and “on” unless the context clearly dictates otherwise.

As used herein, and unless the context dictates otherwise, the term “coupled to” is intended to include both direct coupling (in which two elements that are coupled to each other contact each other) and indirect coupling (in which at least one additional element is located between the two elements). Therefore, the terms “coupled to” and “coupled with” are used synonymously. The terms “coupled to” and “coupled with” are also used euphemistically to mean “communicatively coupled with” where two or more networked devices are able to send or receive data over a network.

Various objects, features, aspects and advantages of the claimed subject matter will become more apparent from the following detailed description, along with the accompanying drawing figures in which like numerals represent like components.

Embodiments of the invention provide a resiliently deformable and flexible in-ear sound device. The in-ear sound device may include flexible electronic components that have been manufactured on a three-dimensional printer.

Embodiments of the in-ear sound device may be used for a variety of purposes, including for use as an amplified hearing device, for use as a music player, and for use as a headphone device.

Embodiments of the invention may provide a smart earplug offering heightened sounds for a variety of uses from personal music player to “walkie-talkie.” Embodiments of the invention provide an in-ear sound device that includes a

wireless communications module that employs a wireless protocol so that the in-ear sound device earplug may communicate with a mobile computing device, another in-ear sound device or a remote server or network, e.g., a cloud.

Embodiments of the invention may further provide an in-ear “smartphone,” e.g., a smart device having functionality rivaling that of a smartphone but using a variety of user interfaces appropriate for an aural rather than visual device, including but not limited to voice recognition technology. The “smartphone” embodiment of the in-ear sound device may also include a visual user interface operating on some form of computing platform, according to an embodiment of the invention.

Electronic component packages used in embodiments of the in-ear sound device may comprise flexible electronic components as, for example, small nano-electronic devices. Electronic components may include a microphone, an amplifier, a battery, a speaker, a wireless communications module, and/or any combination thereof. The electronic component package in some embodiments may include a processor and/or a data storage component. For example, the electronic component may include functionality for executing any number of software applications (“apps”) and/or storing data such as media.

FIG. 1 provides a block diagram that illustrates an in-ear sound device **101**, according to an embodiment of the invention. The in-ear sound device **101** is formed of a deformable and flexible body **110** that contains an electronic component package **102**. The electronic component package **102** is embedded in or on the deformable body **110** and includes electronic circuitry for the in-ear sound device **101**. The specific configuration of the electronic component package **102** may vary from embodiment to embodiment of the in-ear sound device **101**.

The deformable body **110** allows the in-ear sound device **101** to be inserted into a user’s ear canal without damaging the in-ear sound device **101** or causing harm to the subject’s ear. In various embodiments, the electronic component package **102** may be impregnated within the body **110** of the in-ear sound device **101**, disposed on a surface of the body **110**, encased within the body **110**, and/or various other combinations of dispositions. The resiliently deformable material used to form body **110** allows the in-ear sound device **101** to be a “one size fits all” and conform to a broad range of ear canal anatomies.

The electronic component package **102** may include one or more electronic components such as a microphone **103**, a wireless communications module **104**, an amplifier **105**, a battery **113**, a processor **107**, a speaker **108**, and a data storage component **109**, according to an embodiment of the invention. The individual components in the electronic component package **102** may be electrically coupled and/or wired as needed for conventional functionality of such components. Along with the body **110**, the electronic component package **102** may also be deformable in some embodiments of the invention.

Embodiments of the in-ear sound device **101** may include a microphone **103** that communicates with a speaker **108**. The microphone **103** may be in electronic and/or mechanical communication with the speaker **108**. Sound/vibrations picked up by the microphone **103** may be transmitted to the speaker **108**. In some embodiments, the sound/vibrations picked up may be amplified via the amplifier **105** and transmitted to the speaker **108**. In various embodiments, the amplifier **105** includes a digital signal processor (DSP) **112**.

The speaker **108** may be closer to the eardrum than the microphone **103** during operation. (As shown in FIG. 11, a

speaker **1108** is disposed at the proximal tip **1107** of the body of the in-ear sound device **1101** while a microphone **1110** is disposed in the distal portion **1111** of the in-ear sound device **1101**). In some embodiments, the speaker **108** may contact the eardrum or be in even closer proximity to the ear drum than indicated in FIG. 1. The microphone **103** may be external to the ear, or closer to ear canal opening.

In some embodiments, the in-ear sound device **101** itself may be on the order of about 1 mm-5 cm in length. In some embodiments, the distance between the speaker **108** and the microphone **103** may be at a distance between from 1 mm to 5 cm. As a general matter, the greater the distance is between the microphone **103** and the speaker **108**, then there is lower likelihood of feedback issues between the microphone **103** and the speaker **108**.

However, in some embodiments, the dimensions of the in-ear sound device **101** and/or the distance between the microphone **103** and the speaker **108** might be smaller and/or larger than the dimensions/distances provided above. For example, an embodiment of the invention may be prepared for users wearing helmets (e.g., as police officers, soldiers, football players, motorcyclists, and/or bicyclists). Similarly, an embodiment of the in-ear sound device made for security personnel, hunters, etc. might be extended in size to accommodate additional microphones, or higher fidelity microphones, and/or enhanced communications equipment.

In embodiments, audio input to the speaker **108** may come from the wireless communications module **104**, for example when the wireless communications module **104** is configured for Bluetooth®. Additionally, audio input to the speaker **108** may come from the data storage component **109** of the in-ear sound device **101**.

In embodiments, the in-ear sound device **101** further includes a processor **107** which may be integral with the electronic component package **102** or operate under the control of a computing device (e.g., a mobile computing device) sending instructions via the communications module **104**.

The processor **107** in the in-ear sound device **101** may execute software applications **111**, an embodiment of the invention. The software applications **111** may either be stored in the data storage component **109** or delivered to the processor **107** via the communications module **104** from a remote storage device located away from the in-ear sound device **101**. For example, the processor **107** might execute a software application that resides on a mobile phone linked to the in-ear sound device **101**. A skilled artisan will appreciate that many software applications known in the art may be utilized.

The processor **107** may be configured with processor-executable instructions **111** to perform operations to distinguish meaningful sound, such as speech, from ambient noise. Such instructions may perform operations for receiving sound signals from the microphone **103**, such as determining whether the sound signals represent meaningful sound, activating the speaker **108** when the sound signals represent meaningful sound, and deactivating the speaker **108** when the sound signals do not represent meaningful sound. Such instructions **111** for a speech detection program may be present in a memory component **109** of the in-ear sound device **101** or a coupled mobile computing device.

The processor **107** may comprise a CPU or like computing device or may alternatively comprise a simple circuit that directs the operations of the various components in the electronic component package **102**, according to an embodiment of the invention. In embodiments in which the pro-

cessor **107** comprises a simple control circuit, the other components in the electronic component package **102** may also be simple and/or few in number, e.g., just a battery **113**, a data storage component **109**, and a speaker **108**, in addition to the processor **107**.

The data storage component **109** may comprise a non-transitory memory, such as RAM, flash, ROM, hard drive, solid state, drive, optical media and the like. The data storage component **109** may include various types of data, such as media, music, software, and the like.

The wireless communications module **104** can be implemented using a combination of hardware (e.g., driver circuits, antennas, modulators/demodulators, encoders/decoders, and other analog and/or digital signal processing circuits) and software components. Multiple different wireless communication protocols and associated hardware can be incorporated into the wireless communications module **104**.

The wireless communications module **104** includes structural and functional components known in the art to facilitate wireless communication with another computing device or remote network. The wireless communications module **104** can include RF transceiver components such as an antenna and supporting circuitry to enable data communication over a wireless medium, e.g., using Wi-Fi (IEEE 802.11 family standards), Bluetooth® (a family of standards promulgated by Bluetooth SIG, Inc.), or other protocols for wireless data communication. In some embodiments, wireless communications module **104** can implement a short-range sensor (e.g., Bluetooth, BLTE or ultra-wide band).

In some embodiments, the wireless communications module **104** can provide near-field communication (“NFC”) capability, e.g., implementing the ISO/IEC 18092 standards or the like. NFC can support wireless data exchange between devices over a very short range (e.g., 20 centimeters or less). NFC typically involves a near field magnetic induction communication system that provides a short range wireless physical layer that communicates by coupling a tight, low-power, non-propagating magnetic field between devices. In such embodiments, the wireless communication module **104** may include a transmitter coil in the in-ear sound device **101** to modulate a magnetic field which is measured by means of a receiver coil in another device, e.g., another in-ear sound device or a smartphone.

In some embodiments of the invention, the in-ear sound device **101** can communicate bi-directionally via a network. In such embodiments, the wireless communications module **104** may comprise a Bluetooth® digital wireless protocol such that the in-ear sound device **101** may communicate with a mobile computing device. Bluetooth® technology provides a low-cost communication link. The Bluetooth® transceiver in an embodiment of the wireless communications module **104** may be configured to establish a wireless data link with a suitably equipped mobile computing device and/or another in-ear sound device.

In an embodiment, the communications module **104** of the in-ear sound device **101** may operate in conjunction with another in-ear sound device (e.g. one in-ear sound device in a left ear and another in-ear sound device in a right ear), while in another embodiment an in-ear sound device **101** may operate independently. In yet another embodiment, at least one in-ear sound device **101** may operate in conjunction with a mobile computing device.

The in-ear sound device **101** may operate as a walkie-talkie device communicating with another in-ear sound device operating in another ear of the user, with another device associated with the user, with another in-ear sound

device associated with another user, and/or with a third-party device. In some embodiments, a user of the in-ear sound device **101** might be able to communicate with another in-ear sound device user using little more than just a whisper and at great distances.

The in-ear sound device **101** may also include functionality to communicate bi-directionally via a long-range wireless network. In one embodiment, the long-range wireless network includes a cellular network. In another embodiment, the long-range wireless network includes a multimedia communications network. In another embodiment, the long-range wireless network includes wireless technologies such as Global System for Mobile Communications (GSM), Code Division Multiple Access-One (cdmaOne), Time Division Multiple Access (TDMA), PDC, Japan Digital Cellular (JDC), Universal Mobile Telecommunications System (UMTS), Code Division Multiple Access-2000 (cdma2000), and Digital Enhanced Cordless Telephony (DECT).

Embodiments of the in-ear sound device **101** may also include a wireless communications module **104** configured to communicate with a remote server or network. In one embodiment, the remote network is a cloud computing platform.

As used herein, the term "mobile computing device" refers to anyone or all of cellular telephones, tablet computers, phablet computers, personal data assistants (PDAs), palm-top computers, notebook computers, laptop computers, personal computers, wireless electronic mail receivers and cellular telephone receivers (e.g., the BlackBerry® and Treo® devices), multimedia Internet enabled cellular telephones (e.g., BlackBerry Storm®), multimedia enabled smart phones (e.g., Android® and Apple iPhone®), and similar electronic devices that include a programmable processor, memory, a communication transceiver, and a display.

In embodiments, the in-ear sound device **101** may include one or more sensors **106a-106z** configured to detect and/or measure various phenomenon. In one embodiment, the in-ear sound device **101** may include one or more sensors **106a-106z** configured to detect a physiological parameter of the user. Physiological parameters detected or measured by the sensors **106a-106z** may include body temperature, pulse, heart rate, VO<sub>2</sub> Max (also known as maximal oxygen consumption), pulse oximetry data, respiratory rate, respiratory volume, maximum oxygen consumption, cardiac efficiency, heart rate variability, metabolic rate, blood pressure, EEG data, galvanic skin response data, and/or EKG/ECG. Thus, the sensors **106a-106z** may detect, for example, the ambient temperature, humidity, motion, GPS/location, pressure, altitude and blood analytes such as glucose of the user of the in-ear sound device.

In an embodiment, the in-ear sound device **101** may include one or more sensors **106a-106z** configured to detect the location or motion of the user, such as, for example an accelerometer, a GPS sensor, a gyroscope, a magnetometer, and/or radiometer. In an embodiment, the in-ear sound device **101** may include a voice sensor **106a** coupled to the microphone **103**.

Specific sensor **106a-106z** configurations may vary across embodiments of the in-ear sound device **101**, e.g., one embodiment might include an ambient temperature sensor, a heart rate sensor, and a motion sensor while another embodiment includes a pressure sensor, a pulse sensor, and a GPS locator.

In another embodiment, the in-ear sound device **101** may provide various alarm and notification functions. For example, the in-ear sound device **101** may be utilized as an

alarm clock. This functionality could be provided by the processor **107** and/or the processor **107** coupled with the data storage device **109** and/or the processor **107** coupled with the communications module **104** and a third device (e.g., a mobile phone). An ordinary artisan should know how to make the processor **107** may provide an alarm function. In addition, the processor **107** in conjunction, for example, with data stored in the data storage component **109** may provide a calendar function, a timer function, a stopwatch function, and/or a reminder function. Similarly, the processor **107** in combination with data **111** from the data storage component **109** combined with data from various sensors **106a-106z** may provide various alarm and/or warning functions, e.g., a heart attack warning or a high blood pressure warning. Similarly, in conjunction with the communications module **104** and the sensors **106a-106z** could provide various alarms to various third parties remote from the in-ear sound device **101**. For example, if the in-ear sound device **101** was equipped with one or more accelerometer **106a**, then a third party could be automatically notified of an event such as a car crash, a bicycle crash, and/or a fall.

The in-ear sound device **101** can also be configured to provide various forms of authentication. For example, the microphone **103** in combination with the DSP **112**, the processor **107**, and the data storage component **109** using voice data **111** can be used to provide authentication of the authorized user(s) of the in-ear sound device **101**. This electrical component combination could be used to determine when the in-ear sound device **101** has been stolen or otherwise being operated by an unauthorized person. As mentioned above, the processor **107** could be a simple control circuit configured for the authentication function rather than a processor chip configured to control the authentication function. The authentication function could also be used to verify the user before delivering sensitive information through the speaker **108**.

The authentication function could be provided in a number of ways, including but not limited to a voice recognition process known in the art. As disclosed in FIG. **11**, embodiments of the in-ear sound device **1101** include a speaker **1108** disposed at the proximal tip **1107** of the body **1112** of the in-ear sound device **1101** and a microphone **1110** disposed in the distal portion **1111** of the in-ear sound device **1101**. The processor **107** (possibly in conjunction with the DSP **112**) can analyze a received sample of the user's voice.

In an alternative embodiment, authentication may be performed outside the in-ear sound device **101** via a device such as a smartphone. In such an embodiment, the in-ear sound device **101** only needs the microphone **103** and the communications module **104** to perform the authentication function.

A user interface for the electronic component package **102**, including the sensors **106a-106z**, could be provided to the user via the wireless communications module **104** and another device such as a mobile phone or a computer, according to an embodiment of the invention. A voice command user interface could also be provided via the microphone **103** and the processor **107**, according to an embodiment of the invention. An ordinary artisan should know how to configure such a user interface.

Sensors, and combinations of sensors **106a-106z**, may also be used to provide a user interface function. For example, an accelerometer (or a G-force sensor) might activate when a user moves his/her hand near the G-force sensor and provides a certain G-force (e.g., 1G/2G/3G) this action could trigger the sensor such that additional commands might be received through additional actions such as

further tapping. For example, a user might tap his/her jaw, ear, cheek, neck, or another pre-designated location (e.g., via a pre-designated single tap, double tap, or triple tap). This tapping action could trigger the sensor such that additional commands could be received through tapping. So, for example, once the G-force sensor has been activated, then two more taps might activate a music player. The user's selection could be confirmed by appropriate auditory confirmation delivered through the speaker 108. Choices made by the user as well as possible command selections could be spoken to the user via the speaker 108. Similar sensor configurations could also be used for user input functions, such as accelerometers, pulse rate, and temperature sensors.

The in-ear sound device 101 described herein may be waterproof and worn in many situations, such as during swimming or while bathing. The in-ear sound device 101 may also be worn during sleep without discomfort. This may allow the in-ear sound device 101 to be utilized during many times when conventional sound devices may be uncomfortable, simply not work, or even be dangerous to use.

FIG. 2 illustrates an embodiment of an in-ear sound device 201 configured to function as a headphone, according to an embodiment of the invention.

The in-ear sound device 201 comprises a speaker 208, a battery 213, a communication module 204, and a control circuit 207 in an electronic component package 202. The in-ear sound device 201 may comprise additional electronic components in the headphone embodiment. The electronic component package 202 is placed in or on a deformable body 210.

The control circuit 207 may operate in a conventional manner for such circuits, controlling the receipt of data (e.g., music or voice data) from outside the in-ear sound device 201 via the communication module 204 and transferring the data to the speaker 208, with operations powered by the battery 213. The control circuit 207 may in some embodiments comprise a dedicated computer chip (or processor) configured to provide equivalent or superior functionality to a control circuit, according to an embodiment of the invention.

FIG. 3 illustrates an embodiment of an in-ear sound device 301 configured to function as a music player, according to an embodiment of the invention.

The in-ear sound device 301 comprises a speaker 308, a battery 313, a data storage component 309, and a control circuit 307 in an electronic component package 302. The in-ear sound device 301 may comprise additional electronic components in the music player embodiment. The data storage component 309 includes music data 311. The electronic component package 302 is placed in or on a deformable body 310.

The control circuit 307 may operate in a conventional manner for such circuits, obtaining music data 311 from the data storage component 309 and directing transfer of the music data 311 to the speaker 308, with operations powered by the battery 313. The control circuit 307 may in some embodiments comprise a dedicated computer chip (or processor) configured to provide equivalent or superior functionality to a control circuit, according to an embodiment of the invention.

FIG. 4 illustrates an embodiment of an in-ear sound device 401 configured to provide hearing amplification, according to an embodiment of the invention.

The in-ear sound device 401 comprises a speaker 408, a battery 413, a microphone 403, an amplifier 405, and a control circuit 407 in an electronic component package 402. The in-ear sound device 401 may comprise additional elec-

tronic components in the hearing amplification embodiment, such as a digital signal processor (DSP) 412. The electronic component package 402 is placed in or on a deformable body 410.

The control circuit 407 may operate in a conventional manner for such circuits, receiving sound data from the microphone 403, directing transfer of the data to the amplifier 405 (and possibly the DSP 412), and then on to the speaker 408, with operations powered by the battery 413. The control circuit 407 may in some embodiments comprise a dedicated computer chip (or processor) configured to provide equivalent or superior functionality to a control circuit, according to an embodiment of the invention. In some embodiments, the control circuit 407 may also direct the operations of the DSP 412.

FIG. 5 illustrates an embodiment of an in-ear sound device 501 configured to provide a walkie-talkie function (a portable, two-way radio transceiver), according to an embodiment of the invention.

The in-ear sound device 501 comprises a speaker 508, a battery 513, a microphone 503, a communication module 504, and a control circuit 507 in an electronic component package 502. The in-ear sound device 501 may comprise additional electronic components in the walkie-talkie embodiment. The electronic component package 502 is placed in or on a deformable body 510.

The control circuit 507 may operate in a conventional manner for such circuits, receiving sound data from the microphone 503, directing transfer of the data to the speaker 508, with operations powered by the battery 513. The control circuit 507 may in some embodiments comprise a dedicated computer chip (or processor) configured to provide equivalent or superior functionality to a control circuit, according to an embodiment of the invention.

FIG. 6 illustrates an embodiment of an in-ear sound device 610 that employs stretchable circuitry in the electronic component package 611 of the in-ear sound device 610. The electronic component package 611 of the in-ear sound device 610 is embedded in or on a resiliently deformable body 607 and includes stretchable electronic circuitry allowing the in-ear sound device 610 to be inserted into a subject's ear canal without damaging the in-ear sound device 610 or harming the user's ear.

In various embodiments, the electronic component package 611 may be impregnated within the body 607 of the in-ear sound device 610, disposed on a surface of the body 607, encased within the body 607, and/or various combinations of dispositions.

Stretchable electronic circuitry in the electronic component package 611 may comprise an elastomeric substrate such that when it is stretched the components separate relative to each other. In other words, a speaker 605 may become relatively farther away from a microphone 601, according to an embodiment of the invention. When the electronic components are stretched, the electrical interconnection maintains substantially identical electrical performance characteristics. The electrical interconnections are sufficiently elastic such that the stretching may extend the separation distance between the electrical components to many times that of the unstretched distance without degradation of performance for the in-ear sound device 610.

The in-ear sound device 610 includes a microphone 601, a wireless communications module 602, an amplifier 603, a battery 604, and speaker 605. The in-ear sound device 610 may include other components and sensors, such as the components and sensors shown and described with respect to FIG. 1, according to an embodiment of the invention. The

in-ear sound device **610** may include additional components of the same type, e.g., multiple batteries **604**.

In some embodiments of the invention, sub-components of the electronic component of the in-ear sound device **610** are stretchable, e.g., microphone **601**, amplifier **603**, battery **604**, speaker **605**, and wireless communications module **602**. In some embodiments of the invention, the electronic component package **611** may include one or more stretchable components in combination with non-stretchable, traditional components.

FIG. 7 illustrates an in-ear sound device **710**, according to an embodiment of the invention. The in-ear sound device **710** includes a speaker **705** at its proximal tip as shown in FIG. 7, according to an embodiment of the invention. The in-ear sound device **710** otherwise functions in a manner similar to the in-ear sound device **610** shown in FIG. 6 and may contain additional components such as those shown in FIG. 1.

FIG. 8 illustrates an in-ear sound device **810**, according to an embodiment of the invention. The in-ear sound device **810** includes a number of batteries **804**, a wireless communications module **802**, and an amplifier **803**, according to an embodiment of the invention. The in-ear sound device **810** otherwise functions in a manner similar to the in-ear sound device **610** shown in FIG. 6 and may contain additional components such as those shown in FIG. 1.

FIG. 9 illustrates an in-ear sound device **910** having a hole or canal **906** running along its longitudinal axis **908**, according to an embodiment of the invention. The canal **906** extends along the longitudinal axis **908** of a body **901** from the distal region **913** to the proximal region **911**.

Closure of the canal **906** occludes or filters out ambient sound while opening the canal **906** allows outside sound into the ear canal, e.g., the ear canal **1215** shown in FIG. 12. As such, the in-ear sound device **910** may provide the user with variable occlusion.

Having the canal **906** open provides a venting function that reduces dangerous back pressure in the ear canal (e.g., the ear canal **1215** shown in FIG. 12). Having the canal **906** open also reduces the occlusion effect which occurs when an object fills the outer portion of an ear canal giving the user a perception of a hollow or booming echo-like sound for the user's own voice. Thus, opening the canal **906** also facilitates conventional voice communications for the user of the in-ear sound device **910** with other persons, e.g., a flight attendant in an airplane when the wearer of the in-ear sound device **910** is otherwise listening to music. In addition, having the canal **906** open also makes the in-ear sound device **910** fit tighter in the user's ear, which may be helpful during activities such as exercise when the in-ear sound device **910** might be more prone to falling out.

Having the canal **906** closed improves the sound quality delivered to the user's ear. Having the canal **906** closed may also (and/or alternatively) provide additional noise cancellation that improves the quality of the sound delivered to the user's ear. Having the canal **906** closed may also (and/or alternatively) protect a user of the in-ear sound device **910** from very loud sounds and therefore protect the user's hearing. Some users may have the canal **906** in a closed or nearly closed position at all times in order to have the highest possible sound quality delivered to their ear drum, e.g., the ear drum **1204** shown in FIG. 12.

Accordingly, the in-ear sound device **910** may include functionality, such as clamps **914** that can be used to vary the diameter **915** of the canal **906** allowing for the level of occlusion of the ear canal (e.g., the ear canal **1215** shown in FIG. 12) to be adjusted, according to an embodiment of the

invention. The clamps **914** may be integral to the in-ear sound device **910** or may be coupled to the in-ear sound device **910**, according to an embodiment of the invention. The in-ear sound device **910** may include more or fewer claims **914** than the four clamps **914** shown in FIG. 9.

The level of occlusion of the user's ear may be adjusted/actuated by input from the user (by hand) or automatically by the user or by a program using an actuator in the clamp **914** in communication with the other components of the in-ear sound device **910**, such as a processor and a battery (e.g., the processor **107** and the battery **113** shown in FIG. 1). An ordinary artisan should be capable of designing an appropriate mechanism for opening and closing the canal **906** of the in-ear sound device **910**.

In some embodiments, the clamps **914** may be actuated by a touch and/or voice command, depending on the electronic component package (e.g., the electronic component package **101** shown in FIG. 1) provided to the in-ear sound device **910**.

There are several alternative means for controlling the opening and closing of the canal **906** apart from the clamps **914**. Alternative means for closing the canal **906** include pressure pumps, thermodynamic means by adjusting temperature, via chemical means, and via electronic means.

FIG. 10 illustrates an in-ear sound device **1010** having a microphone **1005** at its proximal tip and at least one clamp **1006** for closing a canal (e.g., the canal **906** shown in FIG. 9) in the in-ear sound device **1010**, according to an embodiment of the invention. The in-ear sound device **1010** otherwise resembles the in-ear sound device **910** shown in FIG. 9 and may have an electronic component package similar to the electronic component package **102** shown in FIG. 1, according to an embodiment of the invention.

FIG. 11 illustrates an in-ear sound device **1101** inserted into an ear **1105**, according to an embodiment of the invention. The in-ear sound device **1101** includes a flexible electronics package, such as shown in the in-ear sound device **610** shown in FIG. 6 and/or the electronics component package **102** shown in FIG. 1. Embodiments of the in-ear sound device **1101** include a speaker **1108** disposed at the proximal tip **1107** of the body of the in-ear sound device **1101** and a microphone **1110** disposed in the distal portion **1111** of the in-ear sound device **1101**.

The in-ear sound device **1101** comprises a deformable and flexible body **1112** having a longitudinal axis **1109** extending between a distal end **1111** and a proximal end **1107**. The distal end **1111** resides just outside the ear **1105** so that the in-ear sound device **1101** may be easily removed, according to an embodiment of the invention.

Embodiments of the invention provide an in-ear sound device **1101** composed of a deformable and flexible material that is comfortable to wear for a long period of time and can be produced in bulk eliminating the need for customization. An electronic component package **1113** is embedded in or on the deformable body of the in-ear sound device **1101** and includes electronic circuitry allowing the in-ear sound device **1101** to be inserted into the user's ear canal **1115** without damaging the in-ear sound device **1101** or causing injury to the user's ear **1105**, according to an embodiment of the invention. The electronic component package **1113** may be embedded in the flexible body **1112**, wrapped around the flexible body **1112**, and/or pressed into the flexible body **1112**.

In practical application, the in-ear sound device **1101** is "squished" between the fingers of the user and inserted into the ear canal **1115** where it expands to conform to the shape of the ear canal **1115**.

In some embodiments, the in-ear sound device **1101** may be returned to a “squished” position before removing the in-ear sound device **1101** from the ear canal **1115**. This may allow the in-ear sound device **1101** to slide out of the ear **1105** for easy removal. In other embodiments, the in-ear sound device **1101** may be in an expanded position, or may be in some intermediate position while the in-ear sound device **1101** is removed from the ear canal.

Embodiments of the deformable body **1112** can be fabricated from many resilient polymeric materials known in the art. There are many known resilient polymeric materials that may be used to form in-ear sound devices, such as the in-ear sound device **1101**. For example, natural rubber, neoprene rubber, SBR rubber (styrene block copolymer compounds), silicone rubber, EPDM rubber, polybutadiene rubber, polyvinylchloride elastomers, polyurethane elastomers, ethylene vinyls, acetate elastomers, elastomers based on acrylic acid precursors and vinylalide polymers may all be generally suitable materials which can be used to provide the necessary Shore A Durometer values.

In some embodiments of the invention, the deformable body **1112** of the in-ear sound device **1101** is formed of material that has a Shore A Durometer hardness value (by the technique of ASTM 2240-81) of between about 10 and 30 or between 15 and 25.

The in-ear sound device **1101** may be manufactured by 3D printing in some embodiments, using, for example, a printing apparatus such the 3D printer **1810** shown in further detail in FIG. **18**. The ear plug portion of the device (e.g., the body **1112**) as well as the electronics component package **1113** of the in-ear sound device **1101** are amenable to manufacturer by 3D printing. A few components such as the speaker (e.g., the speaker **108** shown in FIG. **1**) may need to be added to the device **1101** at the end of the manufacturing process since speakers at the moment require post manufacturing tuning that might not yet be possible with some 3D printing machines.

FIG. **11** illustrates an in-ear sound device **1101** inserted into a human ear **1105**. Embodiments of the in-ear sound device **1101** may be configured for non-human ears, such as other primates, other mammals, and even non-mammalian species. Components of the electronics component package and the elastic body would be sized accordingly in these embodiments of the invention.

FIG. **12** illustrates an in-ear sound device **1201** inserted into an ear **1205**, according to an embodiment of the invention. The in-ear sound device **1201** includes a flexible electronics package such as shown in the in-ear sound device **610** shown in FIG. **6** and/or the electronic components package **102** shown in FIG. **1**. The in-ear sound device **1201** also includes a canal **1203** that can be opened and closed using clamps **1204**, according to an embodiment of the invention.

Similar to the discussion of the in-ear sound device **1101** shown in FIG. **11**, in practical application, the in-ear sound device **1201** is “squished” between the fingers of the user and inserted into the ear canal **1215** where it expands to conform to the shape of the ear canal **1215**. In some embodiments, the in-ear sound device **1201** may be returned to a “squished” position before removing the in-ear sound device **1201** from the ear canal **1215**. This may allow the in-ear sound device **1201** to slide out of the ear **1205** for easy removal. In other embodiments, the in-ear sound device **1201** may be in an expanded position, or may be in some intermediate position while the in-ear sound device **1201** is removed from the ear canal.

The body of the in-ear sound device **1201** may be composed of the same materials described with respect to the in-ear sound device **1101** shown in FIG. **11**, according to an embodiment of the invention.

FIG. **13** illustrates an embodiment of the invention that employs stretchable electronics by forming the electronics on discrete islands **1302a**, **1302b** of silicon. FIG. **13** shows a stretchable electronic package **1305** whose discrete electronic islands **1302a**, **1302b** are connected together using interconnects **1301** having a zigzag pattern **1304**, according to an embodiment of the invention. Circuits formed from the stretchable electronics on the discrete islands **130a**, **1302b** remain electrically coupled via the interconnects **1301** regardless of the amount of strain and/or deformation placed on them by the user and the user’s environment.

In embodiments, the discrete islands **1302a**, **1302b** are discretely operative, may function in a “device islands” arrangement, and are capable of performing the functionality described herein (e.g., the functions shown in FIGS. **1-12** above), or portions thereof. In embodiments, the discrete islands **1302a**, **1302b** may include integrated circuits, physical sensors (e.g., temperature, pH, light, radiation etc.), biological and/or chemical sensors, amplifiers, A/D and D/A converters, optical collectors, electro-mechanical transducers, batteries, piezo-electric actuators, light emitting electronics which include LEDs, and combinations thereof. In other words, the sensors **106a-106z** shown in FIG. **1**.

Using conventional integrated circuits (“ICs”) (e.g., CMOS, on single crystal silicon) enables the utilization of high quality, high performance, and high functioning circuit components that are also already commonly mass-produced using well-known processes. These conventional ICs may provide a range of functionality and generation of data typically superior to that produced by more passive devices.

The discrete islands **1302a**, **1302b** may range from about, but not limited to, 10-100  $\mu\text{m}$  in size measured on an edge or by diameter, and connecting the discrete islands **1302a**, **1302b** with one or more extremely stretchable interconnects **1301**. The discrete islands **1302a**, **1302b** may themselves be stretchable or not, according to embodiments of the invention.

The interconnects **1301** have a zigzag pattern **1304** between the discrete islands **1302a**, **1302b**. The zigzag pattern **1304** provides increased stability and simplicity of manufacture. The zigzag pattern **1304** allows for the twisting, turning, stretching and compressing of the discrete islands **1302a**, **1302b** while still allowing the stretchable electronic package **1305** and its various components to maintain electric connectivity.

The geometry of the interconnects **1301** makes these interconnects **1301** extremely pliant. Each interconnect **1301** is patterned and etched so that its structural form has width and thickness dimensions that may be of comparable size (such as their ratio or inverse ratio not exceeding about a factor of 10); and may be preferably equal in size. In embodiments, the dimensions may not be greater than about 5  $\mu\text{m}$  (e.g., where both dimensions are about 1  $\mu\text{m}$  or less).

With reference to embodiments of the invention, the term “stretchable,” and roots and derivations thereof, when used to modify circuitry or components thereof is meant to encompass circuitry that comprises components having soft or elastic properties capable of being made longer or wider without tearing or breaking, and it is also meant to encompass circuitry having components (whether or not the components themselves are individually stretchable as stated above) that are configured in such a way so as to accom-

modate and remain functional when applied to a stretchable, inflatable, or otherwise expandable surface.

Stretchable electronic circuitry attaches at least two isolated electronic components (e.g., the discrete islands **1302a**, **1302b**) to an elastomeric substrate, and arranges an electrical interconnection (e.g., the interconnect **1301**) between the components in a boustrophedonic pattern interconnecting the two isolated electronic components with the electrical interconnection. The elastomeric substrate may then be stretched such that the components separate relative to one another, where the electrical interconnection maintains substantially identical electrical performance characteristics during stretching, and where the stretching may extend the separation distance between the electrical components to many times that of the upstretched distance.

In embodiments, the stretching and compressing may be accomplished by fabricating ICs out of thin membrane single crystal semiconductors, which are formed into “islands” that are mechanically and electrically connected by “interconnects,” and transferring said ICs onto an elastomeric substrate capable of stretching and compressing. The discrete islands **1302a**, **1302b** are regions of non-stretchable/compressible ICs, while the interconnects **1301** are regions of material formed in a way to be highly stretchable/compressible, according to an embodiment of the invention. The underlying elastomeric substrate may be more pliant than the discrete islands **1302a**, **1302b**, so that minimal strain is transferred into the islands **1302a**, **1302b** while the majority of the strain is transferred to the interconnects **1301**, which only contain electrical connections and not less. Each interconnect **1301** attaches one island **1302a** to another island **1302b**, and is capable of accommodating strain between the two aforementioned islands **1302a**, **1302b**, including translation, rotation, or a combination of translation with rotation of one island **1302a** relative to another **1302b**. Even though the interconnects **1301** may be made of a rigid material, they act like weak springs rather than rigid plates or beams. This configuration thereby allows for the making of the extremely stretchable electronics package **1305**.

With reference to embodiments of the invention, the term “stretchable”, and roots and derivations thereof, when used to modify circuitry or components thereof is meant to encompass circuitry that comprises components having soft or elastic properties capable of being made longer or wider without tearing or breaking, and it is also meant to encompass circuitry having components (whether or not the components themselves are individually stretchable as stated above) that are configured in such a way so as to accommodate and remain functional when applied to a stretchable, inflatable, or otherwise expandable surface. The term “expandable,” and roots and derivations thereof, when used to modify circuitry or components thereof is also meant to have the meaning ascribed above. Thus, “stretch” and “expand,” and all derivations thereof, may be used interchangeably when referring to embodiments of the invention.

FIG. **14** illustrates an alternative embodiment of the invention that employs a stretchable electronic package **1405** comprising discrete islands **1402a**, **1402b** bound together using a shorter interconnect **1401** than shown in the interconnect **1301** shown in FIG. **13**, according to embodiment of the invention.

FIG. **15** illustrates an electronics package **1505** comprising discrete islands **1502a**, **1502b**, **1504a**, and **1504b** bound together using zigzag interconnects **1501**, according to an embodiment of the invention. Similar to the discrete islands **1302a**, **1302b** shown in FIG. **13**, the discrete islands **1502a**,

**1502b**, **1504a**, and **1504b** comprise various electronic components, according to an embodiment of the invention.

The use of interconnects **1501** running in a variety of directions from the islands **1502a**, **1502b**, **1504a**, **1504b** allows the islands to be stretched in a variety of directions, according to an embodiment of the invention. The interconnects **1501** may be replaced with or mixed with various other types of interconnects, according to embodiments of the invention.

FIG. **16** illustrates an embodiment of the invention that employs a stretchable electronic package **1605** in which the electronics have been formed on discrete islands **1602a**, **1602b** of silicon bound together using interconnects **1601** having a crisscross or X-pattern **1604**, according to an embodiment of the invention.

In embodiments, the discrete islands **1602a**, **1602b** are discretely operative, may function in a “device islands” arrangement, and are capable of performing the functionality described herein, or portions thereof. In embodiments, the discrete islands **1602a**, **1602b** may include integrated circuits (e.g., the electronic component package **102** shown in FIG. **1**) and sensors (e.g., the sensors **106a-106z** shown in FIG. **1**), other electronic components, and combinations thereof.

FIG. **17** illustrates an electronics package **1705** bound to another stretchable electronics package **1706** using zigzag interconnects **1703**. The electronics package **1705** has been formed from electronics located on discrete islands **1704a**, **1704b** held together using zigzag interconnects **1701**. Similarly, the electronics package **1706** has been formed from electronics on discrete islands **1707a**, **1707b** also held together using zigzag interconnects **1701**. The two electronics packages **1705** and **1706** are bound to each other using zigzag interconnects **1703**.

The use of interconnects **1701** running in a variety of directions from the islands **1704a**, **1704b**, **1707a**, **1707b** allows the islands to be stretched in a variety of directions, according to an embodiment of the invention. The interconnects **1701** may be replaced with or mixed with various other types of interconnects, according to embodiments of the invention.

FIG. **18** illustrates a three-dimensional (3D) printer **1810** that may form an in-ear sound device **1832**. In general, 3D printing is an additive part-forming technique that incrementally builds an object by applying a plurality of successive thin material layers. The 3D printer **1810** includes a print head **1812** configured to controllably deposit/bind a stock material onto a substrate. The stock material may comprise an electronic component package **1814** (e.g., the electronic component package **611** shown in FIG. **6**) bound to the material **1816** of the earplug (e.g., the deformable body **607** shown in FIG. **6** and/or electronic component package **102** shown in FIG. **1**). A motion controller **1818** is configured to controllably translate the print head **1812** within a predefined workspace. The techniques described with respect to FIG. **18** are applicable to a type of 3D printing known as Fused Filament Fabrication. Other types and forms of 3D printers may be used to print the in-ear sound device **1832**. The print head **1812** may be configured to receive the material for the electronic component package **1814** from a source such as a spool **1820** or hopper, melt the stock material (e.g., using a resistive heating element **1822**), and expel the molten material for the electronic component package **1814** onto the substrate of the ear plug **1816** via a nozzle **1824**. In general, the nozzle **1824** may define an orifice **1826** at its distal tip **1828** through which the molten material **1814** may exit the print head **1812**.

Once out of the nozzle **1824**, the molten material for the electronic component package **1814** may begin cooling, and may re-solidify onto the substrate of the ear plug **1816**. Where the molten electronic component package material **1814** is applied over a previously formed material layer **1834** (e.g., a portion of the earplug), the temperature of the molten stock material **1814** may cause localized surface melting to occur in the previous material layer **1834**. This localized melting may aid in bonding the newly applied material with the previous layers **1834**.

In one embodiment, the print head **1812** may be controlled within a Cartesian coordinate system **1836**, where three actuators can each cause a resultant motion of the print head **1812** in a respective orthogonal plane (where convention defines the X-Y plane as a plane parallel to the work surface **1830**, and the Z-direction as a dimension orthogonal to the work surface **1830**). As material for the electronic component package **1814** is applied to the substrate of the earplug **1816**, the thickness **1838** and width of the applied material bead may be a function of the motion **1840** of the print head **1812** relative to the substrate of the earplug **1816**, as well as the rate at which the solid stock material of the electronic component package **1814** is fed into the print head **1812**. For a constant print head motion **1840** and constant feed rate for the solid stock material for the electronic component package **1814**, each applied material bead may have a substantially constant height/thickness **1838** and width.

Some components of the electronic components package **1814** might not be amendable to printing using a 3D printer because of various post-production requirements. For example, speakers (e.g., the speaker **108** shown in FIG. 1) generally require tuning which often requires stretching. Thus, in some embodiments, the in-ear sound device **1832** may be primarily manufactured using the 3D printer **1810** with some additional components, such as a speaker, added at the end of production or at some phase during the product not controlled by the 3D printer **1810** (e.g., added by another device or inserted by hand). This should be relatively simple for the speaker since the speaker is typically located at an end of the in-ear sound device **1832**. A fully tuned speaker could be added to the end of the semi-finished in-ear sound device using a mechanical production apparatus, for example.

In embodiments, the in-ear sound device **1832** may be considered disposable and may be intended for single or limited use due to the reduced cost of the device.

FIG. 19 illustrates an in-ear sound device **1901** communicating wirelessly with other devices **1906**, **1909**, **1911**, and **1914**, according to an embodiment of the invention.

A communications module **1904** on the in-ear sound device **1901** may be configured to communicate wirelessly with a communication module **1907** on an in-ear sound device **1906** paired with the in-ear sound device **1901**. In other words, a user might wear the in-ear sound device **1901** in a left ear, and the in-ear sound device **1906** might be worn in the user's right ear. The in-ear sound device **1901** may communicate wirelessly with the paired in-ear sound device **1906** using a variety of communications protocols, such as NFC communications as discussed above.

The in-ear sound device **1901** may also be in communication with another in-ear sound device **1909** via the communications module **1908** on the in-ear sound device **1909**. The communication module **1904** may use a different communication protocol in communicating with the communications module **1908** on the in-ear sound device **1909** than

the in-ear sound device **1901** uses with a closely tethered device such as the in-ear sound device **1906**.

The in-ear sound device **1901** may also communicate with a transceiver **1910** on a mobile phone **1911**. The mobile phone **1911** may be a device such as smartphone. The communications module **1904** may use a different communication protocol than used to communicate with the in-ear sound device **1906** or the in-ear sound device **1909**.

The in-ear sound device **1901** may also communicate with a remote data server **1913** located on a remote computing device **1914** via a communication module **1912** associated with the remote data server **1913**. The remote data server **1913** may, for example, comprise a server and even a cloud computing device, according to an embodiment of the invention.

The in-ear sound device **1901** may not necessarily be equipped to communicate with all the devices **1906**, **1909**, **1911**, and **1914**. The communication module **1904** may be configured for just one type of communication, according to an embodiment of the invention. Similarly, the communication module **1904** may be configured for communications using a series of different communications protocols.

It should be apparent to those skilled in the art that many more modifications of the in-ear sound device besides those already described are possible without departing from the inventive concepts herein. The inventive subject matter, therefore, is not to be restricted except in the scope of the appended claims. Moreover, in interpreting both the specification and the claims, all terms should be interpreted in the broadest possible manner consistent with the context. In particular, the terms "comprises" and "comprising" should be interpreted as referring to elements, components, or steps in a non-exclusive manner, indicating that the referenced elements, components, or steps may be present, or utilized, or combined with other elements, components, or steps that are not expressly referenced.

While specific embodiments of the invention have been illustrated and described, it will be clear that the invention is not limited to these embodiments only. Embodiments of the invention discussed herein may have generally implied the use of materials from certain named equipment manufacturers; however, the invention may be adapted for use with equipment from other sources and manufacturers. Equipment used in conjunction with the invention may be configured to operate according to conventional protocols (e.g., USB) and/or may be configured to operate according to specialized protocols. Numerous modifications, changes, variations, substitutions and equivalents will be apparent to those skilled in the art without departing from the spirit and scope of the invention as described in the claims. In general, in the following claims, the terms used should not be construed to limit the invention to the specific embodiments disclosed in the specification, but should be construed to include all systems and methods that operate under the claims set forth hereinbelow. Thus, it is intended that the invention covers the modifications and variations of this invention provided they come within the scope of the appended claims and their equivalents.

We claim:

1. An in-ear monitoring device, comprising:
  - a deformable and flexible body having a longitudinal axis extending between a distal end and a proximal end;
  - an electronic component package comprising stretchable electronic circuitry, wherein the electronic component package includes at least one sensor configured to measure a data element in proximity of the in-ear monitoring device and wherein the stretchable elec-

tronic circuitry is at least one of embedded in or on the deformable and flexible body;

a processor in the electronic component package configured to analyze the data element and take an action if the data element exceeds a threshold wherein the at least one sensor and the processor are configured to operate as a measurement device that provides one of an alarm, a stop watch, a calendar, and a notification function and wherein the action if the data element exceeds the threshold related to the measurement device comprises preparing a notification; and

a communication module in communication with a remote device that sends the notification to the remote device if the data element exceeds the threshold.

2. The in-ear monitoring device of claim 1 wherein the measurement device operates as an alarm and wherein the at least one sensor is configured as at least one of a thermometer, a pulse rate monitor, a heart rate monitor, a VO<sub>2</sub> Max monitor, a pulse oximetry monitor, a respiratory rate monitor, a respiratory monitor, an oxygen consumption monitor, a cardiac efficiency monitor, a heart rate variability monitor, a metabolic rate monitor, a blood pressure monitor, an EEG data monitor, a galvanic skin response monitor, an EKG/ECG monitor, a blood analyte monitor, an ambient temperature monitor, a humidity monitor, a motion detector, a GPS locator, a pressure sensor, an altitude sensor, an accelerometer, a gyroscope, and a magnetometer.

3. The in-ear monitoring device of claim 1, further comprising:

a speaker located at the proximal end of the deformable and flexible body wherein the notification is also played through the speaker to a wearer of the in-ear monitoring device.

4. The in-ear monitoring device of claim 1, further comprising:

a microphone in the electronic component package configured to receive sounds external to the in-ear monitoring device,

wherein the processor is further configured to analyze the sounds received by the microphone, separate meaningful sounds from ambient noise, and provide notice information about the meaningful sounds to the remote device via the communication module.

5. The in-ear monitoring device of claim 4, further comprising:

a data repository containing identification data pertaining to the meaningful sounds, wherein the processor's analysis of the received sound data from the microphone comprises determining if the received sound data matches the identification data and generating the notice information if the identification data matches the received sound data.

6. The in-ear monitoring device of claim 5 wherein the remote device takes an action upon receipt of the notice information from the communication module.

7. The in-ear monitoring device of claim 5 wherein the notice information comprises the meaningful sounds and wherein the remote device analyzes the meaningful sounds to determine if it should take an action.

8. The in-ear monitoring device of claim 1 wherein the remote device is a mobile telephony device.

9. The in-ear monitoring device of claim 1 wherein the deformable and flexible body is composed of a material having a Shore A Durometer hardness value between 10 and 30.

10. The in-ear monitoring device of claim 1 wherein the communication module is configured to receive data from the remote device using at least one of Bluetooth, Wi-Fi, BLTE, near-field communication, Global System for Mobile Communications (GSM), Code Division Multiple Access-One (cdmaOne), Time Division Multiple Access (TDMA),

PDC, Japan Digital Cellular (JDC), Universal Mobile Telecommunications System (UMTS), Code Division Multiple Access-2000 (cdma2000), near-field communication (NFC) and Digital Enhanced Cordless Telephony (DECT).

11. An in-ear sound sensing device, comprising:

a deformable and flexible body having a longitudinal axis extending between a distal end and a proximal end;

an electronic component package comprising stretchable electronic circuitry, wherein electronic components in the electronic component package include a microphone configured to receive sounds external to the in-ear sound sensing device, wherein the stretchable electronic circuitry is at least one of embedded in or on the deformable and flexible body, and wherein electrical interconnects of the electronic circuitry connecting electronic components of the electronic component package comprise an elastic material;

a processor in the electronic components of the electronic component package configured to analyze the sounds received by the microphone, separate meaningful sounds from ambient noise, and provide notice information about the meaningful sounds to a remote device; and

a communication module in the electronic components of the electronic component package that delivers the notice information about the meaningful sounds to the remote device.

12. The in-ear sound sensing device of claim 11, further comprising:

a data repository containing identification data pertaining to the meaningful sounds, wherein the processor's analysis of the received sound data from the microphone comprises determining if the received sound data matches the identification data, wherein the processor generates the notice information if the identification data matches the received sound data.

13. The in-ear sound sensing device of claim 12 wherein the remote device takes an action upon receipt of the notice information from the communication module.

14. The in-ear sound sensing device of claim 11 wherein the notice information comprises the meaningful sounds and wherein the remote device analyzes the meaningful sounds to determine an appropriate action.

15. The in-ear sound sensing device of claim 14 wherein the remote device is a mobile telephony device.

16. The in-ear sound sensing device of claim 11, further comprising:

at least one sensor in the electronic component package configured to measure a data element, wherein the processor analyzes the data element and takes an action if the data element exceeds a threshold wherein the at least one sensor and the processor are configured to operate as a measurement device that provides at least one of an alarm, a stop watch, a calendar, and a notification function and wherein the action if the data element exceeds the threshold related to the measurement device comprises sending a notification to the remote device via the communication module.

17. The in-ear sound sensing device of claim 16, further comprising:

a speaker located at the proximal end of the deformable and flexible body wherein the notification is also played through the speaker to a wearer of the in-ear sound sensing device.

18. The in-ear sound sensing device of claim 11 wherein the deformable and flexible body is composed of a material having a Shore A Durometer hardness value between 10 and 30.

19. The in-ear sound sensing device of claim 11 wherein the deformable and flexible body includes a canal along the longitudinal axis that extends from the distal end to the proximal end, the deformable and flexible in-ear sound device further comprising:

a plurality of clamps configured to open and close the canal, wherein opening the canal lowers back pressure in an ear of the user of the in-ear sound sensing device.

20. The in-ear sound sensing device of claim 11 wherein the electronic components of the electronic component package comprise an elastic material.

21. A method for providing an in-ear monitoring device, comprising:

measuring a data element in a proximity of the in-ear monitoring device by at least one sensor in an electronic component package comprising stretchable electronic circuitry, the electronic component package residing in a deformable and flexible body having a longitudinal axis extending between a distal end and a proximal end, wherein the stretchable electronic circuitry is at least one of embedded in or on the deformable and flexible body;

analyzing the data element by a processor in the electronic component package configured to and take an action if the data element exceeds a threshold wherein the at least one sensor and the processor are configured to operate as a measurement device that provides one of an alarm, a stop watch, a calendar, and a notification function and wherein the action if the data element exceeds the threshold related to the measurement device comprises preparing a notification; and

sending the notification to a remote device by a communication module if the data element exceeds the threshold.

22. The method of claim 21 wherein the measurement device operates as an alarm and wherein the at least one sensor is configured as at least one of a thermometer, a pulse rate monitor, a heart rate monitor, a VO<sub>2</sub> Max monitor, a pulse oximetry monitor, a respiratory rate monitor, a respiratory monitor, an oxygen consumption monitor, a cardiac efficiency monitor, a heart rate variability monitor, a metabolic rate monitor, a blood pressure monitor, an EEG data monitor, a galvanic skin response monitor, an EKG/ECG monitor, a blood analyte monitor, an ambient temperature monitor, a humidity monitor, a motion detector, a GPS locator, a pressure sensor, an altitude sensor, an accelerometer, a gyroscope, and a magnetometer.

23. The method of claim 21, further comprising: playing the notification to a wearer of the in-ear monitoring device by a speaker located at the proximal end of the deformable and flexible body.

24. The method of claim 21, further comprising: receiving sounds external to the in-ear monitoring device by a microphone in the electronic component package; and analyzing the sounds received in the microphone by the processor to separate meaningful sounds from ambient noise and providing notice information about the meaningful sounds to the remote device via the communication module.

25. The method of claim 24, further comprising: storing identification pertaining to the meaningful sounds in a data repository, wherein the processor's analysis of the received sound data from the microphone comprises determining if the received sound data matches

the identification data and generating the notice information if the identification data matches the received sound data.

26. The method of claim 25, further comprising: taking an action by the remote device upon receipt of the notice information from the communication module.

27. The method of claim 25 wherein the notice information comprises the meaningful sounds, the method further comprising:

analyzing the meaningful sounds by the remote device to determine if it should take an action.

28. The method of claim 21 wherein the remote device is a mobile telephony device.

29. The method of claim 21 wherein the deformable and flexible body is composed of a material having a Shore A Durometer hardness value between 10 and 30.

30. The method of claim 21 wherein the communication module transmits data to the remote device using at least one of Bluetooth, Wi-Fi, BL TE, near-field communication, Global System for Mobile Communications (GSM), Code Division Multiple Access-One (cdmaOne), Time Division Multiple Access (TDMA), PDC, Japan Digital Cellular (JDC), Universal Mobile Telecommunications System (UMTS), Code Division Multiple Access-2000 (cdma2000), near-field communication (NFC) and Digital Enhanced Cordless Telephony (DECT).

31. A method for providing an in-ear sound sensing device, comprising:

receiving sounds external to the in-ear sound sensing device by a microphone in electronic components of an electronic component package comprising stretchable electronic circuitry, wherein the stretchable electronic circuitry is at least one of embedded in or on a deformable and flexible body having a longitudinal axis extending between a distal end and a proximal end and wherein electrical interconnects of the electronic circuitry connecting electronic components of the electronic component package comprise an elastic material; analyzing the sounds received in the microphone by a processor in the electronic components of the electronic component package configured to separate meaningful sounds from ambient noise and to provide notice information about the meaningful sounds to a remote device; and

delivering the notice information about the meaningful sounds to the remote device by a communication module in the electronic components of the electronic component package.

32. The method of claim 31, further comprising: storing identification data pertaining to the meaningful sounds in a data repository in the electronic component package, wherein the processor's analysis of the received sound data from the microphone comprises determining if the received sound data matches the identification data; and

generating the notice information by the processor if the identification data matches the received sound data.

33. The method of claim 32, further comprising: taking an action by the remote device when it receives the notice information from the communication module.

34. The method of claim 31 wherein the notice information comprises the meaningful sounds, the method further comprising:

analyzing the meaningful sounds by the remote device to determine an appropriate action.

35. The method of claim 34 wherein the remote device is a mobile telephony device.

36. The method of claim 31, further comprising:  
measuring a data element by at least one sensor in the  
electronic component package; and  
analyzing the data element by the processor and taking an  
action if the data element exceeds a threshold, wherein 5  
the at least one sensor and the processor are configured  
to operate as a measurement device that provides at  
least one of an alarm, a stop watch, a calendar, and a  
notification function and wherein the action if the data  
element exceeds the threshold related to the measure- 10  
ment device comprises sending a notification to the  
remote device via the communication module.

37. The method of claim 36, further comprising:  
playing the notification to a wearer of the in-ear sound  
sensing device by a speaker located at the proximal end 15  
of the deformable and flexible body.

38. The method of claim 31 wherein the deformable and  
flexible body is composed of a material having a Shore A  
Durometer hardness value between 10 and 30.

39. The method of claim 31 wherein the deformable and 20  
flexible body includes a canal along the longitudinal axis  
that extends from the distal end to the proximal end, the  
method further comprising:

opening and closing the canal by a plurality of clamps,  
wherein opening the canal lowers back pressure in an 25  
ear of the user.

40. The method of claim 31 wherein the electronic  
components of the electronic component package comprise  
an elastic material.

\* \* \* \* \*

专利名称(译)	智能灵活的交互式耳塞		
公开(公告)号	<a href="#">US9794668</a>	公开(公告)日	2017-10-17
申请号	US15/413338	申请日	2017-01-23
申请(专利权)人(译)	SMARTEAR INC.		
当前申请(专利权)人(译)	SMARTEAR INC.		
[标]发明人	MASAKI KINUKO GARDNER DEAN VALENZUELA VICTOR		
发明人	MASAKI, KINUKO GARDNER, DEAN VALENZUELA, VICTOR		
IPC分类号	H04R1/10 H04R1/02 H04R25/00 H04M1/60 G10L17/22 G10L25/51 H04W4/00 H04R1/04 A61B5/00 A61B5/1455 A61B5/0205 A61B5/024 A61B5/08 A61B5/021 A61B5/0476 A61B5/11 A61B5/0402 A61B5/053		
CPC分类号	H04R1/1016 A61B5/02055 A61B5/14551 A61B5/6817 G10L17/22 G10L25/51 H04M1/6058 H04R1/028 H04R1/04 H04R1/1041 H04R1/1058 H04R1/1083 H04R25/652 A61B5/021 A61B5/024 A61B5/02405 A61B5/0402 A61B5/0476 A61B5/0533 A61B5/0816 A61B5/11 A61B2562/0219 A61B2562/0223 H04R25/505 H04R2201/103 H04R2201/107 H04R2420/07 H04R2460/11 A61B5/6803 H04W4/80 A61B5/04 H04R3/00 H04R2203/00		
优先权	62/072776 2014-10-30 US		
其他公开文献	US20170238081A1		
外部链接	<a href="#">Espacenet</a> <a href="#">USPTO</a>		

摘要(译)

本发明的一个实施例提供了一种可弹性变形且柔性的入耳式声音装置，其具有可拉伸的电子电路。耳内声音设备可以以各种方式配置，包括但不限于智能耳塞，柔性个人声音放大产品，个人音乐播放器，“对讲机”等。

