



(19) **United States**

(12) **Patent Application Publication** (10) **Pub. No.: US 2016/0367197 A1**  
Addison et al. (43) **Pub. Date: Dec. 22, 2016**

(54) **SYSTEMS AND METHODS FOR REDUCING SIGNAL NOISE WHEN MONITORING AUTOREGULATION**

(52) **U.S. Cl.**  
CPC ..... *A61B 5/7246* (2013.01); *A61B 5/14542* (2013.01); *A61B 5/0205* (2013.01); *A61B 5/14546* (2013.01); *A61B 5/742* (2013.01); *A61B 5/021* (2013.01)

(71) Applicant: **COVIDIEN LP**, MANSFIELD, MA (US)

(72) Inventors: **Paul S. Addison**, Edinburgh (GB);  
**Dean Montgomery**, Edinburgh (GB);  
**James N. Watson**, Edinburgh (GB)

(57) **ABSTRACT**

(21) Appl. No.: **15/184,305**

(22) Filed: **Jun. 16, 2016**

**Related U.S. Application Data**

(60) Provisional application No. 62/181,067, filed on Jun. 17, 2015.

**Publication Classification**

(51) **Int. Cl.**  
*A61B 5/00* (2006.01)  
*A61B 5/0205* (2006.01)  
*A61B 5/145* (2006.01)

A method for monitoring autoregulation includes, using a processor, receiving a blood pressure signal, a regional oxygen saturation signal, and a blood volume signal from a patient. The method also includes determining a first linear correlation between the blood pressure signal and the regional oxygen saturation signal and determining a second linear correlation between the blood pressure signal and the blood volume signal. The method also includes determining a confidence level associated with the first linear correlation based at least in part on the second linear correlation and providing a signal indicative of the patient's autoregulation status to an output device based on the linear correlation and the confidence level.

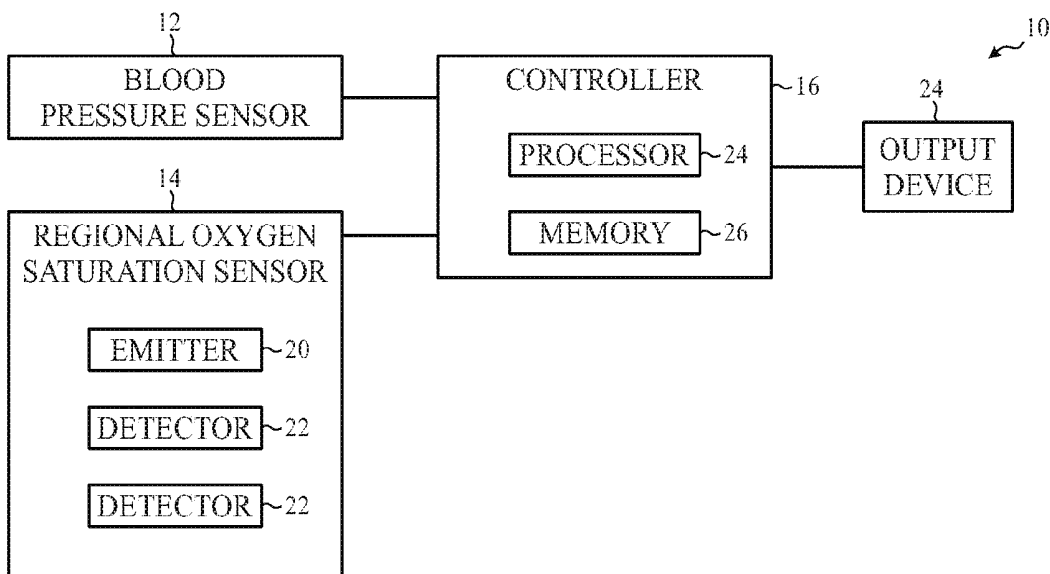

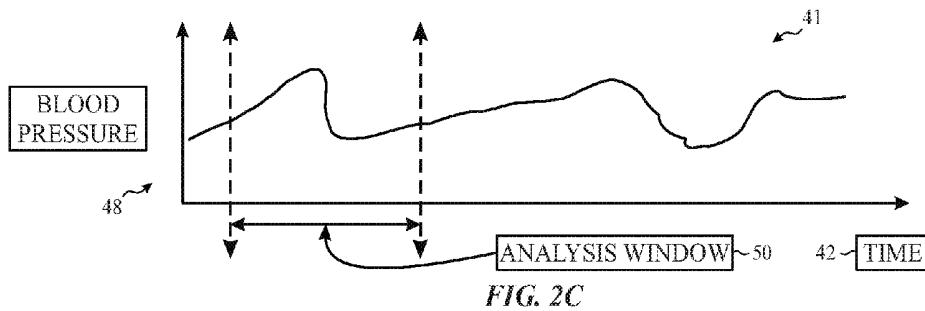
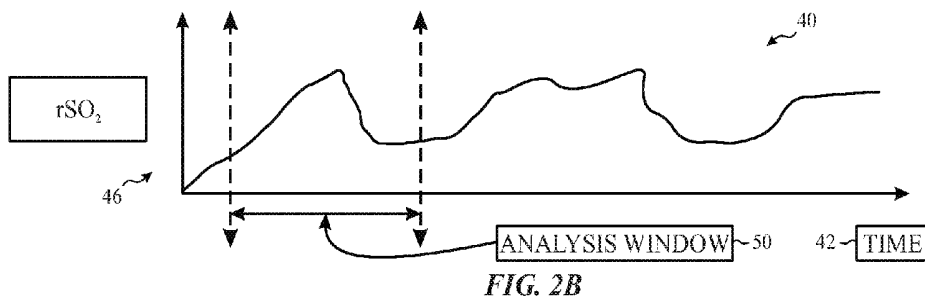
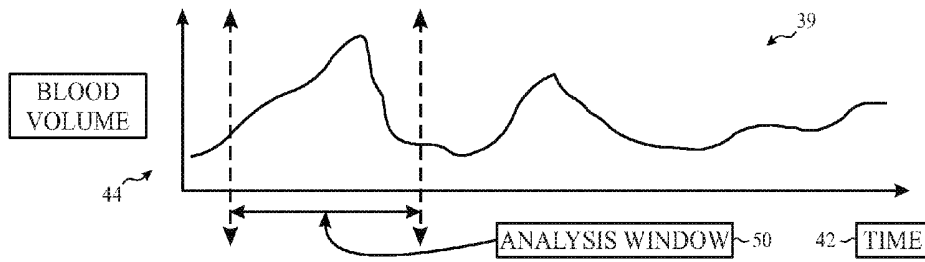
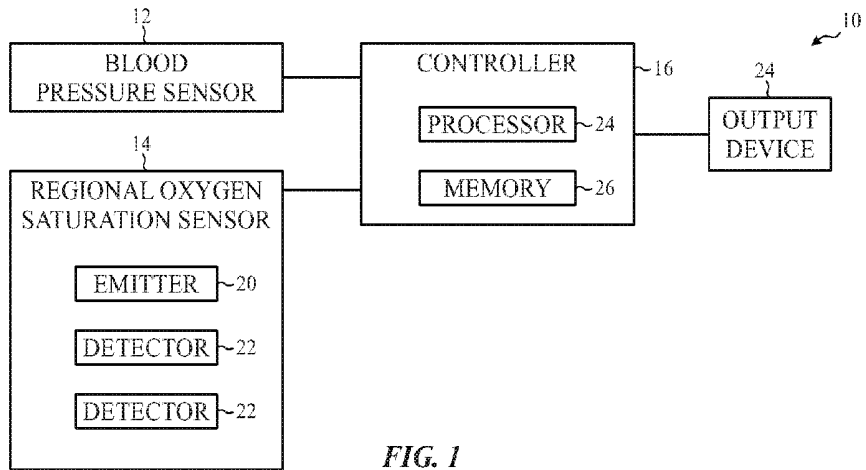

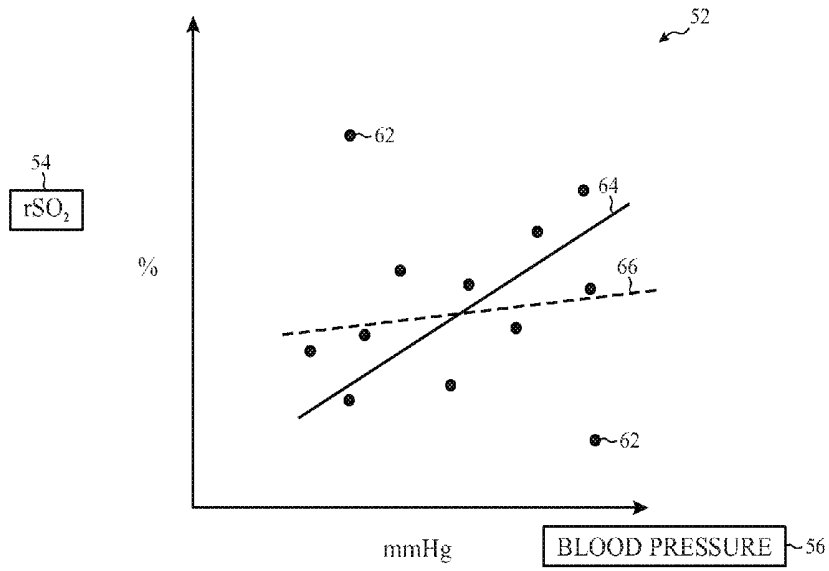

FIG. 3A

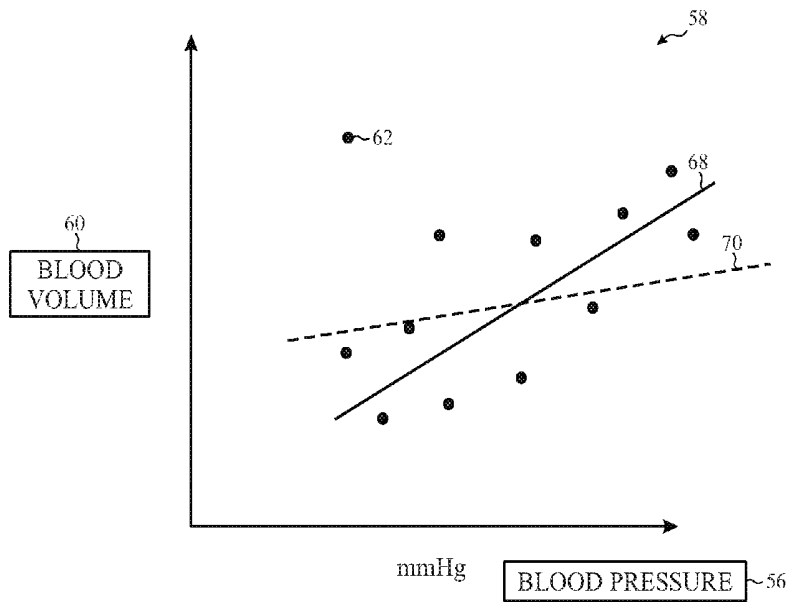

FIG. 3B

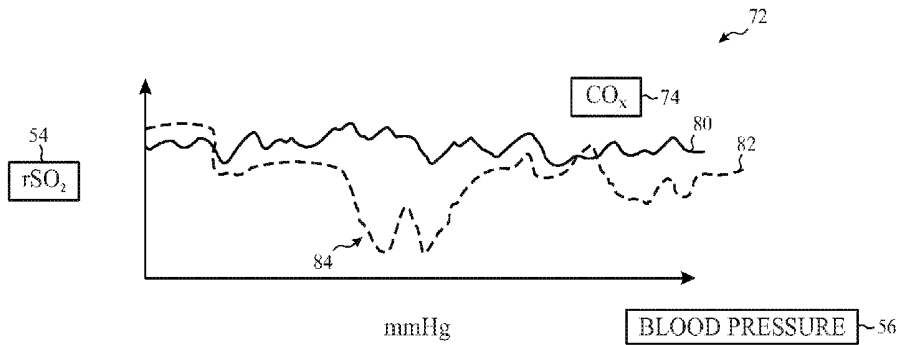

FIG. 4A

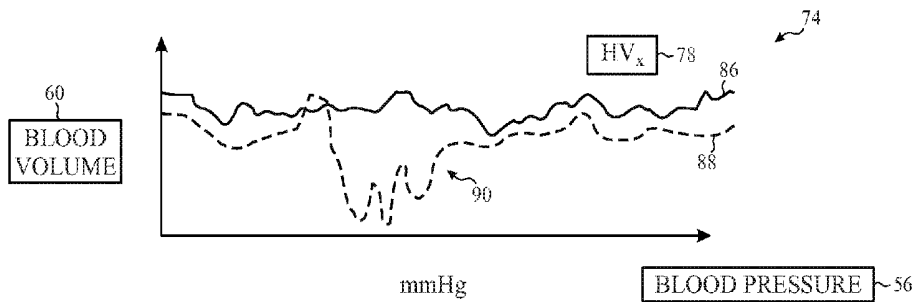

FIG. 4B

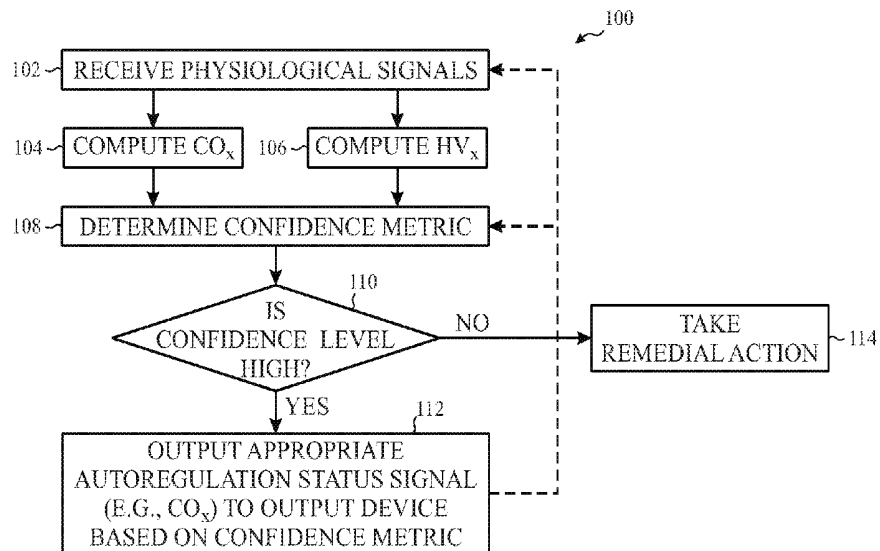

FIG. 5

| 74<br>CO <sub>x</sub> | 98<br>HV <sub>x</sub> | 122<br>AUTOREGULATION<br>STATUS | 124<br>VASCULAR<br>REACTIVITY | 126<br>CONFIDENCE<br>LEVEL |
|-----------------------|-----------------------|---------------------------------|-------------------------------|----------------------------|
| < 0                   | < 0                   | INTACT                          | INTACT                        | HIGH                       |
| < 0                   | > 0                   | INTACT                          | IMPAIRED                      | LOW                        |
| > 0                   | < 0                   | IMPAIRED                        | INTACT                        | LOW                        |
| > 0                   | > 0                   | IMPAIRED                        | IMPAIRED                      | HIGH                       |

FIG. 6

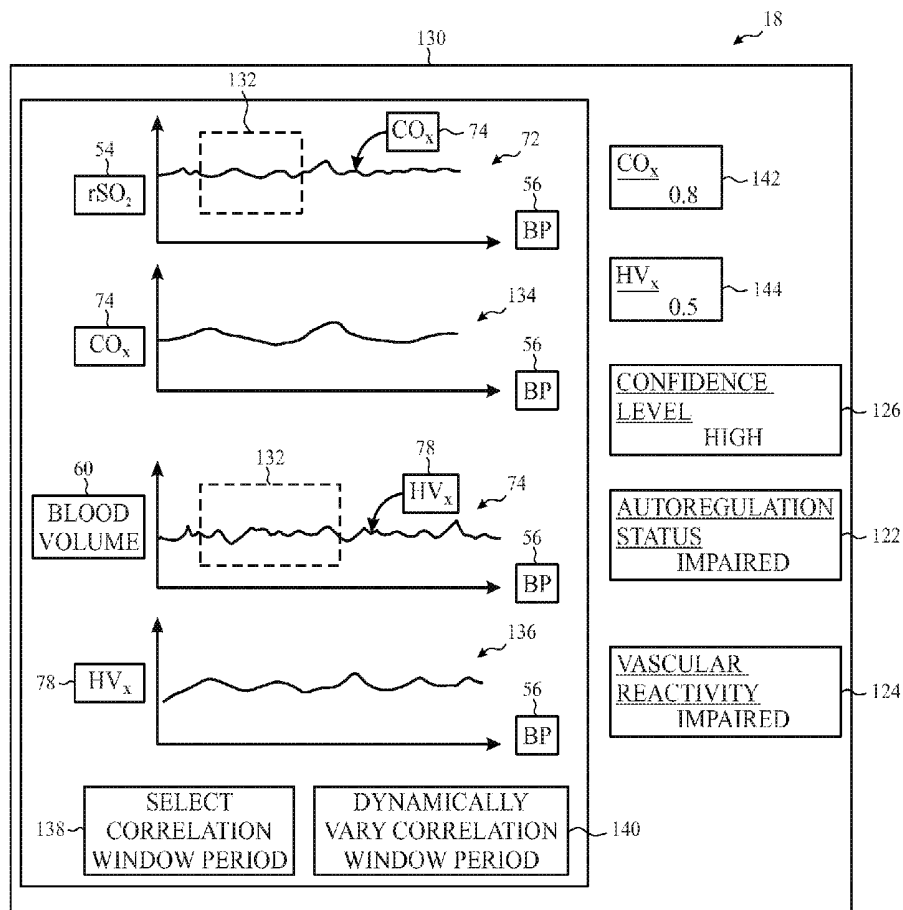
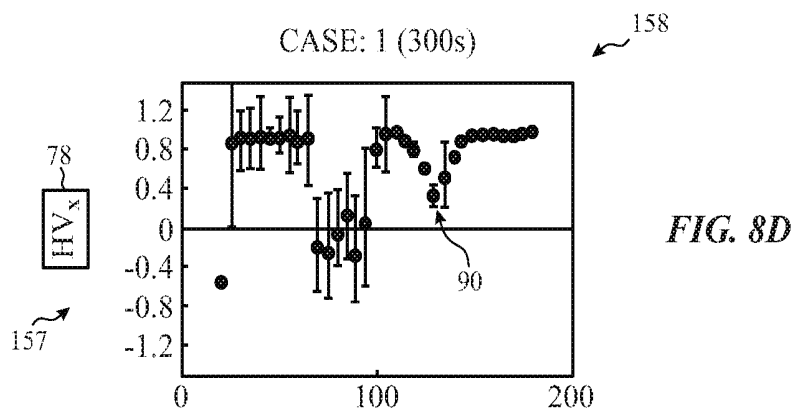
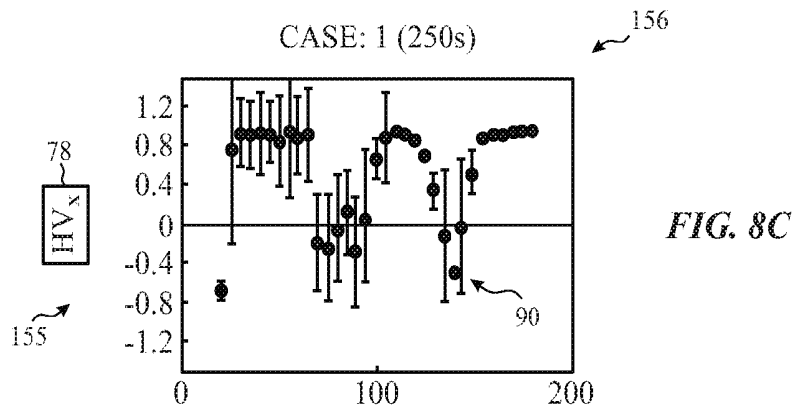
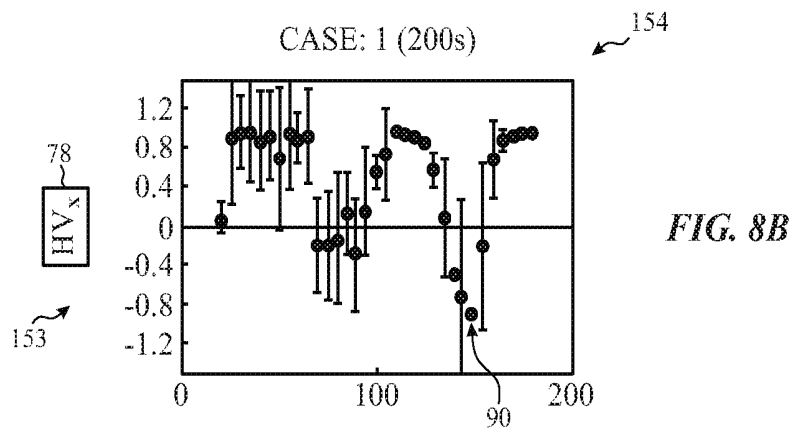
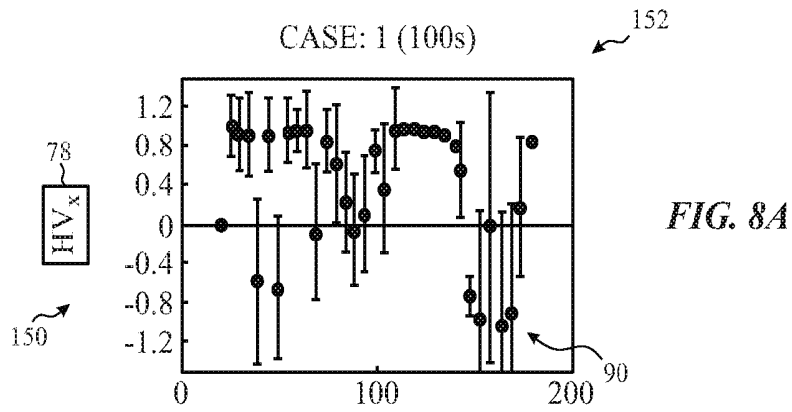

FIG. 7



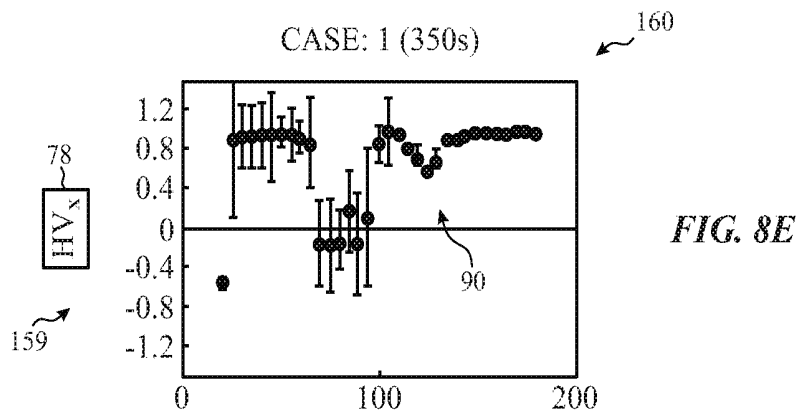

FIG. 8E

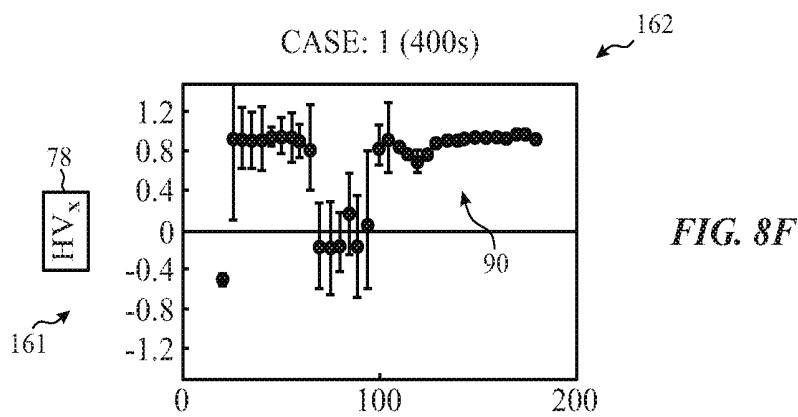

FIG. 8F

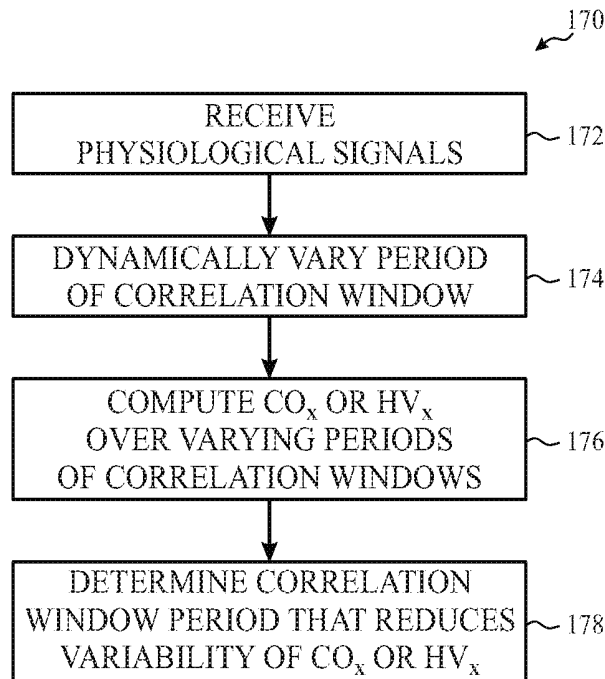

FIG. 9

## SYSTEMS AND METHODS FOR REDUCING SIGNAL NOISE WHEN MONITORING AUTOREGULATION

### CROSS-REFERENCE TO RELATED APPLICATIONS

[0001] The present application claims the benefit of U.S. Provisional Application No. 62/181,067, which was filed on Jun. 17, 2015, and entitled “SYSTEMS AND METHODS FOR REDUCING SIGNAL NOISE WHEN MONITORING AUTOREGULATION”, the disclosure of which is incorporated herein by reference in its entirety.

### BACKGROUND

[0002] The present disclosure relates generally to medical devices and, more particularly, to systems and methods for monitoring autoregulation.

[0003] This section is intended to introduce the reader to various aspects of art that may be related to various aspects of the present disclosure, which are described and/or claimed below. This discussion is believed to be helpful in providing the reader with background information to facilitate a better understanding of the various aspects of the present disclosure. Accordingly, it should be understood that these statements are to be read in this light, and not as admissions of prior art.

[0004] In the field of medicine, medical professionals often desire to monitor certain physiological parameters of their patients. In some cases, clinicians may wish to monitor a patient's autoregulation. Autoregulation is a physiological process that attempts to maintain an optimal cerebral blood flow to supply appropriate levels of oxygen and nutrients to the brain. During autoregulation, cerebral arterioles dilate or constrict to maintain optimal blood flow. For example, as cerebral pressure decreases, cerebral arterioles dilate in an attempt to maintain blood flow. As cerebral pressure increases, cerebral arterioles constrict to reduce the blood flow that could cause injury to the brain. If the patient's autoregulation process is not functioning properly, the patient may experience inappropriate cerebral blood flow, which may have negative effects on the patient's health. In particular, a drop in cerebral blood flow may cause ischemia, which may result in tissue damage or death of brain cells. An increase in cerebral blood flow may cause hyperemia, which may result in swelling of the brain or edema.

[0005] Some existing systems for monitoring autoregulation may determine a patient's autoregulation status based on various physiological values. Such physiological values may be subject to various sources of error, such as noise caused by motion, operator error, poor quality measurements, drugs, or other anomalies. However, existing systems for monitoring autoregulation may not reduce the various sources of error when utilizing the measured physiological values to determine the patient's autoregulation status. Furthermore, existing systems may not determine and/or utilize a reliable metric to determine whether the autoregulation status calculated from the physiological values is reliable. Accordingly, the autoregulation status determined by such existing systems may be inaccurate or unreliable.

### BRIEF DESCRIPTION OF THE DRAWINGS

[0006] Advantages of the disclosed techniques may become apparent upon reading the following detailed description and upon reference to the drawings in which:

[0007] FIG. 1 is a block diagram of an embodiment of a system for monitoring autoregulation of a patient;

[0008] FIG. 2A is an example of a graph illustrating a blood volume signal obtained from the patient over a period of time;

[0009] FIG. 2B is an example of a graph illustrating an oxygen saturation signal obtained from the patient over a period of time;

[0010] FIG. 2C is an example of a graph illustrating a blood pressure signal obtained from the patient over a period of time;

[0011] FIG. 3A is an example of a first graph illustrating linear correlations between the oxygen saturation measurements obtained from the oxygen saturation signal of FIG. 2B and the blood pressure measurements obtained from the blood pressure signal of FIG. 2C;

[0012] FIG. 3B is an example of a second graph illustrating linear correlations between the blood volume measurements obtained from the blood volume signal of FIG. 2A and the blood pressure measurements obtained from the blood pressure signal of FIG. 2C;

[0013] FIG. 4A is an example of a first graph illustrating a cerebral oximetry index obtained from the first graph of FIG. 3A;

[0014] FIG. 4B is an example of a second graph illustrating a hemoglobin volume index obtained from the second graph of FIG. 3B;

[0015] FIG. 5 is a process flow diagram of a method of monitoring autoregulation based on a confidence metric, in accordance with an embodiment;

[0016] FIG. 6 is a table illustrating example correlations between the cerebral oximetry index, the hemoglobin volume index, an autoregulation status of the patient, a vascular reactivity status of the patient, and a computed confidence level;

[0017] FIG. 7 is an embodiment of a display configured to display various information related to monitoring the autoregulation of a patient, including the cerebral oximetry index and the hemoglobin volume index computed over a correlation window;

[0018] FIGS. 8A-8F are embodiments of graphs depicting the hemoglobin volume index across one or more correlation windows having different periods; and

[0019] FIG. 9 is a process flow diagram of a method for monitoring autoregulation of a patient based on a correlation window having a period that reduces sources of error, in accordance with an embodiment.

### DETAILED DESCRIPTION OF SPECIFIC EMBODIMENTS

[0020] One or more specific embodiments of the present techniques will be described below. In an effort to provide a concise description of these embodiments, not all features of an actual implementation are described in the specification. It should be appreciated that in the development of any such actual implementation, as in any engineering or design project, numerous implementation-specific decisions must be made to achieve the developers' specific goals, such as compliance with system-related and business-related constraints, which may vary from one implementation to another. Moreover, it should be appreciated that such a development effort might be complex and time consuming, but would nevertheless be a routine undertaking of design,

fabrication, and manufacture for those of ordinary skill having the benefit of this disclosure.

**[0021]** A physician may monitor a patient's autoregulation through the use of various monitoring devices and systems that measure various physiological parameters. In certain embodiments of the present disclosure, a patient's autoregulation may be monitored by correlating measurements of the patient's blood pressure (e.g., arterial blood pressure) with measurements of the patient's oxygen saturation (e.g., regional oxygen saturation). In particular, a cerebral oximetry index (COx) may be derived based at least in part on a linear correlation between the patient's blood pressure and oxygen saturation. In addition, in certain embodiments of the present disclosure, the patient's autoregulation may be monitored by correlating measurements of the patient's blood pressure with measurements of the patient's blood volume (e.g., blood volume proxy). In particular, a hemoglobin volume index (HVx) may be derived based at least in part on a linear correlation between the patient's blood pressure and blood volume. While features of the present disclosure are discussed with reference to COx and HVx, it should be noted that in other embodiments, various other linear correlations may be determined to help evaluate a patient's autoregulation. For example, a linear correlation between measurements of a patient's blood pressure and measurements of a patient's cerebral blood flow may derive a mean velocity index (Mx). As a further example, a linear correlation between measurements of a patient's blood pressure and measurements of a patient's intracranial pressure may derive a pressure reactivity index (PRx). In certain situations, these indexes may be utilized to determine or help evaluate a patient's autoregulation.

**[0022]** The disclosed systems and methods may determine linear correlations between the measured physiological parameters using regression analyses. For example, the system may be configured to apply a least median of squares (LMS) regression method or a least trimmed squares regression method (LTS) to oxygen saturation measurements plotted against blood pressure measurements to determine a regression line associated with COx. As noted above, during patient monitoring, physiological values may be affected by noise. These regression methods may enable the system to ignore or exclude data outliers representative of the noise, and to utilize the remaining data to determine the COx or HVx. Accordingly, the calculated COx or HVx may have less variability due to signal noise and may be less susceptible to data outliers. In certain embodiments, the system may evaluate the quality of the data with one or more quality metrics in order to determine which portions of the data are included or excluded from the regression methods.

**[0023]** Further, the disclosed systems and methods may determine a confidence metric in order to determine the reliability of the calculated COx or HVx. Existing systems and methods may determine a significance value (p value) related to the COx to determine whether the portions of the calculated COx are reliable or unreliable. In the disclosed systems and methods, it may be beneficial to determine the reliability of the COx or HVx based on a confidence metric. For example, in certain embodiments, the system may utilize HVx as a confidence metric for COx, or COx as a confidence metric for HVx, as further described below. In certain embodiments, the system may determine the confidence metric based on a combination parameter, which may be calculated as the mean or weighted average of the COx and

HVx. In addition, in certain embodiments, the system may determine the confidence metric based on a linear correlation confidence coefficient, which may be calculated by correlating the COx with the HVx. Accordingly, the system may utilize the confidence metric to evaluate the reliability of the calculated COx or HVx, which may be used to accurately monitor the patient's autoregulation.

**[0024]** In addition, the disclosed systems and methods may be configured to calculate COx or HVx over a correlation window having a particular period (e.g., length measured in seconds). For example, a correlation window having a particular period may incrementally scan a continuous signal representative of the oxygen saturation measurements plotted against the blood pressure measurements to calculate the COx. The correlation window may have a period of 100 seconds, 150 seconds, 200 seconds, 250 seconds, 300 seconds, 350 seconds, 400 seconds, and so forth. In certain embodiments, such as in situations where the confidence metric evaluates a low reliability of the autoregulation status, the system may be configured to dynamically vary the period of the correlation window to compute or recompute the COx or HVx. In certain embodiments, a user or operator may manually select or vary the period of the correlation window to compute or recompute the COx or HVx. Varying the period of the correlation window allows the system to exclude or ignore portions of the COx or HVx with high variability, thereby improving the reliability of the COx or HVx, which may be used to accurately monitor the patient's autoregulation.

**[0025]** Accordingly, the system may be configured to exclude or ignore data caused by noise when calculating the COx or HVx to improve the reliability of the COx or HVx. Further, the system may determine a confidence metric to evaluate the reliability of the COx or HVx. In this manner, the system may be configured to accurately and reliably monitor autoregulation of a patient for a medical professional, as discussed in more detail below.

**[0026]** FIG. 1 illustrates an embodiment of a system 10 for monitoring an autoregulation of a patient. As shown, the system 10 includes a blood pressure sensor 12, an oxygen saturation sensor 14 (e.g., a regional oxygen saturation sensor), a controller 16, and an output device 18. As further described in detail below, the blood pressure sensor 12 may be any sensor or device configured to obtain the patient's blood pressure (e.g., arterial blood pressure). The oxygen saturation sensor 14 may be any sensor or device configured to obtain the patient's oxygen saturation signal indicative of blood oxygen saturation within one or more regions of the patient. The oxygen saturation sensor 14 and the blood pressure sensor 12 may also determine various other physiological parameters from the patient, such as blood volume or blood volume proxy, cerebral blood flow, intracranial pressure, or other types of information that may be useful to determine a patient's autoregulation status. The controller 16 may be configured to gather physiological signals measured by the sensors (e.g., blood pressure sensor 12, regional oxygen saturation sensor 14, etc.) to evaluate the patient's autoregulation, and may be configured to output information related to the autoregulation status to the output device 18.

**[0027]** In certain embodiments, the blood pressure sensor 12 may include a blood pressure cuff for non-invasively monitoring blood pressure or an arterial line for invasively monitoring blood pressure. In certain embodiments, the blood pressure sensor 12 may include one or more pulse

oximetry sensors. In some such cases, the patient's blood pressure may be derived by processing time delays between two or more characteristic points within a single plethysmography (PPG) signal obtained from a single pulse oximetry sensor. Various techniques for deriving blood pressure based on a comparison of time delays between certain components of a single PPG signal obtained from a single pulse oximetry sensor is described in U.S. Publication No. 2009/0326386, entitled "Systems and Methods for Non-Invasive Blood Pressure Monitoring," the entirety of which is incorporated herein by reference. In other cases, the patient's blood pressure may be continuously, non-invasively monitored via multiple pulse oximetry sensors placed at multiple locations on the patient's body. As described in U.S. Pat. No. 6,599,251, entitled "Continuous Non-invasive Blood Pressure Monitoring Method and Apparatus," the entirety of which is incorporated herein by reference, multiple PPG signals may be obtained from the multiple pulse oximetry sensors, and the PPG signals may be compared against one another to estimate the patient's blood pressure. Regardless of its form, the blood pressure sensor 12 may be configured to generate a blood pressure signal indicative of the patient's blood pressure (e.g., arterial blood pressure) over time. As discussed in more detail below, the blood pressure sensor 12 may provide the blood pressure signal to the controller 16 or to any other suitable processing device to enable evaluation of the patient's autoregulation status.

**[0028]** As shown, the oxygen saturation sensor 14 may be a regional oxygen saturation sensor configured to generate an oxygen saturation signal indicative of blood oxygen saturation within the venous, arterial, and capillary systems within a region of the patient. For example, the oxygen saturation sensor 14 may be configured to be placed on the patient's forehead and may be used to calculate the oxygen saturation of the patient's blood within the venous, arterial, and capillary systems of a region underlying the patient's forehead (e.g., in the cerebral cortex).

**[0029]** In such cases, the oxygen saturation sensor 14 may include an emitter 20 and multiple detectors 22. The emitter 20 may include at least two light emitting diodes (LEDs), each configured to emit at different wavelengths of light, e.g., red or near infrared light. In one embodiment, the LEDs of the emitter 20 emit light in the range of about 600 nm to about 1000 nm. In a particular embodiment, one LED of the emitter 20 is configured to emit light at about 730 nm and the other LED of the emitter 20 is configured to emit light at about 810 nm. One of the detectors 22 is positioned relatively "close" (e.g., proximal) to the emitter 20 and one of the detectors 22 is positioned relatively "far" (e.g., distal) from the emitter 22. Light intensity of multiple wavelengths may be received at both the "close" and the "far" detectors 22. For example, if two wavelengths are used, the two wavelengths may be contrasted at each location and the resulting signals may be contrasted to arrive at a regional saturation value that pertains to additional tissue through which the light received at the "far" detector passed (tissue in addition to the tissue through which the light received by the "close" detector passed, e.g., the brain tissue), when it was transmitted through a region of a patient (e.g., a patient's cranium). Surface data from the skin and skull may be subtracted out, to generate a regional oxygen saturation (rSO<sub>2</sub>) signal for the target tissues over time. In certain embodiments, an isosbestic wavelength and/or an isosbestic point on the wavelengths may be utilized to extract infor-

mation related to blood volume and generate a blood volume signal for the patient over time. As discussed in more detail below, the oxygen saturation sensor 14 may provide the regional oxygen saturation signal and/or the blood volume signal to the controller 16 or to any other suitable processing device to enable evaluation of the patient's autoregulation status.

**[0030]** In operation, the blood pressure sensor 12 and the oxygen saturation sensor 14 may each be placed on the same or different parts of the patient's body. Indeed, the blood pressure sensor 12 and the oxygen saturation sensor 14 may in some cases be part of the same sensor or supported by a single sensor housing. For example, the blood pressure sensor 12 and the oxygen saturation sensor 14 may be part of an integrated oximetry system configured to non-invasively measure blood pressure (e.g., based on time delays in a PPG signal) and regional oxygen saturation. One or both of the blood pressure sensor 12 or the oxygen saturation sensor 14 may be further be configured to measure other parameters over time, such as blood volume or blood volume proxy, cerebral blood flow, intracranial pressure, hemoglobin, respiratory rate, respiratory effort, heart rate, saturation pattern detection, response to stimulus such as bispectral index (BIS) or electromyography (EMG) response to electrical stimulus, or the like. In certain embodiments, other types of sensors or monitoring techniques (e.g., photoacoustic spectroscopy) may be used to determine these physiological parameters over time. While an exemplary system 10 is shown, the exemplary components illustrated in FIG. 1 are not intended to be limiting. Indeed, additional or alternative components and/or implementations may be used.

**[0031]** In certain embodiments, the blood pressure sensor 12 and the oxygen saturation sensor 14 may be configured to provide the oxygen saturation signal, the blood pressure signal, and a blood volume signal to the controller 16. In certain embodiments, the controller 16 is an electronic controller having electrical circuitry configured to process the various received signals. In particular, the controller 16 may be configured to process the blood pressure signal, the oxygen saturation signal, and the blood volume signal to evaluate the patient's cerebral autoregulation status. Although the blood pressure sensor 12 and the oxygen saturation sensor 14 may be configured to provide their respective signals or data directly to the controller 16, in certain embodiments, the signals or data obtained by the blood pressure sensor 12 and/or the oxygen saturation sensor 14 may be provided to one or more intermediate processing devices (e.g., specialized monitor, such as a blood pressure monitor or an oxygen saturation monitor, or the like), which may in turn provide processed signals or data to the controller 16.

**[0032]** As discussed in more detail below, the controller 16 may be configured to determine a cerebral oximetry index (COx) based on the blood pressure signal and the oxygen saturation signal. Further, in some embodiments, the controller 16 may be configured to determine a hemoglobin volume index (HVx) based on the blood pressure signal and the blood volume signal. The COx is indicative of vascular reactivity, which is related to cerebral blood vessels' ability to control proper blood flow, via vasoconstriction (a narrowing of the blood vessel) and/or vasodilation (expansion of the blood vessel), for example. The HVx is indicative of pressure reactivity, which is related to cerebral blood ves-

self's ability to control proper intracranial pressure, for example. Thus, COx and HVx may also be indicative of whether the patient's autoregulation is impaired, and one or more of these parameters may be utilized to evaluate a patient's autoregulation status.

**[0033]** The controller 16 may derive the COx in part by determining a linear correlation between blood pressure measurements and oxygen saturation measurements. Likewise, the controller 16 may derive the HVx in part by determining a linear correlation between blood pressure measurements and blood volume measurements. Specifically, the controller 16 may be configured to determine COx by applying one or more regression techniques (e.g., least medium of square (LMS), least trimmed squares (LTS)) to the oxygen saturation measurements plotted against the blood pressure measurements and determine HVx by applying one or more regression techniques to the blood volume measurements plotted against the blood pressure measurements, as further described with respect to FIGS. 3A-4B. The result of applying these regression techniques is a regression line between the physiological measurements that ignore or exclude data outliers indicative of noise within the received signals. Accordingly, the resulting COx or HVx may exhibit less variability due to signal noise and may be more stable and reliable. The controller 16 may be configured to determine the patient's autoregulation status based on the regression lines that are associated with the COx and the HVx. For example, in certain embodiments, the controller 16 may determine a slope of the regression line associated with the COx, which may be between -1 and +1, inclusive, where 1 represents total negative correlation, +1 represents total positive correlation, and 0 represents the absence of correlation between the blood pressure measurements and the oxygen saturation measurements. Thus, COx values between -1 and 0 may suggest that cerebral autoregulation is working properly, while COx values between 0 and 1 may suggest that the cerebral autoregulation is impaired. In some cases, a predetermined threshold between 0 and 1 may be utilized to determine whether the patient's autoregulation is impaired. For example, in some embodiments, the controller 16 may be configured to determine that the patient's autoregulation is impaired when the COx value is greater than 0.1, 0.2, 0.3, 0.4, 0.5, 0.6, 0.7, 0.8, or 0.9. Accordingly, the controller 16 may be configured to determine the COx value and/or the patient's autoregulation status based on the linear correlation between the blood pressure measurements and oxygen saturation measurements obtained by the blood pressure sensor 12 and the oxygen saturation sensor 14, respectively. Likewise, the controller 16 may be configured to determine the HVx value and/or the patient's autoregulation status based on the linear correlation between the blood volume measurements and the blood pressure measurements.

**[0034]** As discussed in greater detail with respect to FIGS. 5-6, the controller 16 may determine a confidence metric to determine the reliability of the calculated COx or HVx. Indeed, it may be beneficial to determine the reliability of the calculated COx or HVx to accurately monitor the patient's autoregulation. In certain embodiments, the controller 16 may be utilized to determine and display COx on the output device 18 as an indicator of the patient's autoregulation, and may determine HVx in the background as a confidence metric for the COx. Specifically, the controller 16 may assign a high confidence level for the COx if the

COx and HVx have the same polarity (e.g., both COx and HVx are positive or both COx and HVx are negative). Likewise, in certain embodiments, the controller 16 may determine and display the HVx on the output device 18 as an indicator of the patient's autoregulation, and may determine COx in the background as a confidence metric for the HVx. In certain embodiments, the controller 16 may determine a confidence metric based on a combination parameter, which may be calculated as the mean or weighted average of the calculated COx and HVx. In certain embodiments, the controller 16 may determine a confidence metric based on a second linear correlation coefficient, which may be calculated by correlating the COx with the HVx. Specifically, the COx values are plotted against the HVx values and the controller 16 may be configured to determine a linear correlation between the values. Further, the controller 16 may be configured to determine a second linear correlation coefficient and utilize the second linear correlation coefficient as the confidence metric.

**[0035]** As discussed in greater detail with respect to FIGS. 7-9, the controller 16 may calculate COx or HVx over a correlation window having a particular period. For example, COx may be calculated over a correlation window of 300 seconds for a continuous signal of the oxygen saturation measurements plotted against the blood pressure measurements. The correlation window may have a period of 100 seconds, 150 seconds, 200 seconds, 250 seconds, 300 seconds, 350 seconds, 400 seconds, and so forth. In certain embodiments, the controller 16 may be configured to dynamically vary the period of the correlation window to exclude or ignore portions of the oxygen saturation measurements plotted against the blood pressure measurements with great variability and less stability (e.g., noise). In certain embodiments, such as in situations where the confidence metric indicates that calculated COx or HVx are less reliable, the system may be configured to dynamically vary the period of the correlation window to calculate or recalculate the COx or HVx to reduce the variability and improve the reliability. In some situations, the system may evaluate multiple periods of the correlation window to calculate the COx or HVx from a correlation window having a period that reduces variability resulting from noise. It should be noted that in some situations, the controller 16 may be configured to vary the correlation window to identify one or more stable portions of the COx or HVx, which may be a reliable indication of the patient's autoregulation status. Further, in some embodiments, an operator may manually vary or select the period of the correlation window to prompt the system to calculate or recalculate the COx or HVx.

**[0036]** In the illustrated embodiment, the controller 16 includes a processor 24 and a memory device 26. The controller 16 may also include one or more storage devices. The processor 24 may be used to execute software, such as software for carrying out any of the techniques disclosed herein, such as processing the signals received from the blood pressure sensor 12 or the oxygen saturation sensor 14, determining the COx or HVx values, determining a confidence metric, determining the reliability of the COx or HVx, determining regions of COx or HVx that exhibit stability, varying the period of the correlation window to determine regions of stability, determining an autoregulation status of the patient, carrying out appropriate remedial actions, and so forth. Moreover, the processor 24 may include multiple microprocessors, one or more "general-purpose" micropro-

processors, one or more special-purpose microprocessors, and/or one or more application specific integrated circuits (ASICs), or some combination thereof. For example, the processor 24 may include one or more reduced instruction set (RISC) processors.

[0037] The memory device 26 may include a volatile memory, such as random access memory (RAM), and/or a nonvolatile memory, such as ROM. The memory device 26 may include one or more tangible, non-transitory, machine-readable media collectively storing instructions executable by the processor 24 to perform the methods and control actions described herein. Such machine-readable media can be any available media that can be accessed by the processor 24 or by any general purpose or special purpose computer or other machine with a processor. The memory device 26 may store a variety of information and may be used for various purposes. For example, the memory device 26 may store processor-executable instructions (e.g., firmware or software) for the processor 24 to execute, such as instructions for carrying out any of the techniques disclosed herein, such as processing the signals received from the blood pressure sensor 12 or the oxygen saturation sensor 14, determining the COx or HVx values, determining a confidence metric, determining the reliability of the COx or HVx, determining regions of COx or HVx that exhibit stability, varying the period of the correlation window to determine regions of stability, determining an autoregulation status of the patient, carrying out appropriate remedial actions, and so forth. The storage device(s) (e.g., nonvolatile storage) may include read-only memory (ROM), flash memory, a hard drive, or any other suitable optical, magnetic, or solid-state storage medium, or a combination thereof. The storage device(s) may store data (e.g., the blood pressure value, the oxygen saturation value, the blood volume value, the COx, the HVx, the confidence metric, the confidence level, etc.), instructions (e.g., software or firmware for processing the blood pressure signal, the oxygen saturation signal, and/or the blood volume signal, determining the COx and/or the HVx, determining the confidence metric, dynamically or manually varying the period of the correlation window, determining an autoregulation status of the patient, and/or taking appropriate remedial actions), predetermined thresholds, and any other suitable data.

[0038] As shown, the system 10 includes the output device 18. In some embodiments, the controller 16 may be configured to provide signals indicative of the patient's autoregulation status to the output device 18. As discussed in more detail below, the controller 16 may be configured to generate an alarm signal indicative of the patient's autoregulation status and to provide the alarm signal to the output device 18. The output device 18 may include any device configured to receive signals (e.g., the signal indicative of the patient's autoregulation status, the alarm signal, or the like) from the controller 16 and visually and/or audibly output information indicative of the patient's autoregulation status (e.g., the COx value, the HVx value, the COx signal, the HVx signal, an alarm, or the like). For instance, the output device 18 may include a display configured to provide a visual representation of the patient's autoregulation status and/or the alarm signal as determined by the controller 16. Additionally or alternatively, the output device 18 may include an audio device configured to provide sounds in accordance with the alarm signal, the patient's autoregulation status, or both. The output device 18 may be any suitable device for conveying

such information, including a computer workstation, a server, a desktop, a notebook, a laptop, a handheld computer, a mobile device, or the like. In some embodiments, the controller 16 and the output device 18 may be part of the same device or supported within one housing (e.g., a computer or monitor).

[0039] FIGS. 2A-2C are examples of graphs illustrating physiological values obtained from the patient over a period of time 42 from one or more sensors. Specifically, FIG. 2A is an example of a graph 39 illustrating a blood volume value 44 obtained from the patient over the period of time 42. Further, FIG. 2B is an example of a graph 40 illustrating an oxygen saturation value 46 (e.g., regional oxygen saturation value, rSO<sub>2</sub>, etc.) obtained from the patient over the period of time 42. In addition, FIG. 2C is an example of a graph 41 illustrating a blood pressure value 48 obtained over the period of time 42. As an example, the blood pressure value 48 is described in mmHg units, however, any appropriate unit or measurement may be utilized. It should be noted that the blood volume value 44, the oxygen saturation value 46, and/or the blood pressure value 48 may be obtained from one or both of the blood pressure sensor 12 and the oxygen saturation sensor 14. The period of time 42 over which the physiological values are measured may be different for each signal and/or each sensor, and may be provided to the controller 16 continuously or intermittently over the period of time 42. As noted above, in certain embodiments, other types of physiological values may be measured and provided to the controller 16, such as any physiological signal that may be useful in determining an autoregulation status of a patient (e.g., intracranial pressure, blood flow, cerebral blood flow, etc.).

[0040] The controller 16 may be configured to monitor autoregulation of a patient based on one or more of the physiological values received from the patient. Specifically, the controller 16 may determine the COx based in part on a linear correlation between the oxygen saturation signal 46 and the blood pressure signal 48, and utilize the COx as an indicator of the patient's autoregulation. In particular, the controller 16 may be configured to plot oxygen saturation measurements derived from the oxygen saturation signal 46 against blood pressure measurements derived from the blood pressure signal 48 over an overlapping analysis window 50 having a particular length of time. The analysis window 50 may be any portion of the period of time 42 where two physiological values are measured from the same patient at the same time. As described in detail with respect to FIG. 3A, the controller 16 may be configured to plot the oxygen saturation measurements against the blood pressure measurements over the analysis window 50 to determine a linear correlation between measurements obtained at the same time.

[0041] Further, in certain embodiments, the controller 16 may determine the HVx based on the linear correlation between the blood volume signal 44 and the blood pressure signal 48, and utilize the HVx as an indicator of the patient's autoregulation status. Accordingly, the controller 16 may be configured to plot blood volume measurements derived from the blood volume signal 44 against blood pressure measurements derived from the blood pressure signal 48 over the overlapping analysis window 50. As described in detail with respect to FIG. 3B, the controller 16 may be configured to plot the blood volume measurements against the blood pressure measurements over the analysis window to deter-

mine a linear correlation between the measurements obtained at the same time. It should be noted that the controller 16 may determine both the COx and HVx, so that one may be used as the confidence metric for the other when determining the reliability of the patient's autoregulation. Further, in situations where the controller 16 utilizes the HVx as a confidence metric for the COx or utilizes COx as a confidence metric for the HVx, the analysis window 50 may be the same across the physiological measurements utilized to calculate the COx and HVx.

[0042] FIG. 3A is an example of a first graph 52 illustrating linear correlations between the oxygen saturation measurements 54 (e.g., regional oxygen saturation measurements) plotted against the blood pressure measurements 56. In addition, FIG. 3B depicts an example of a second graph 58 illustrating linear correlations between the blood volume measurements 60 plotted against the blood pressure measurements 56. As noted above, the oxygen saturation measurements 54, the blood volume measurements 60, and the blood pressure measurements 56 may be derived from the oxygen saturation value 46, the blood volume value 44, and the blood pressure value 48, respectively. Additionally, as noted above, the physiological measurements may be plotted against each other over the analysis window 50.

[0043] Specifically, in certain embodiments, the controller 16 may utilize various linear regressions analyses to determine a best fit regression line that fits the physiological measurements. Existing systems may utilize a least squares method (LS) to fit, for example, the oxygen saturation measurements plotted against the blood pressure measurements to determine a regression line associated with the COx. However, the least squares linear regression method may be more susceptible to outliers 62 (e.g., measurements indicative of noise), and the LS fit may not be a reliable indicator of the patient's autoregulation, as further described below. Accordingly, the present embodiments describe utilizing a least median of squares (LMS) regression method to fit the physiological measurements, which may be more robust to outliers 62 and may be a more reliable indicator of the patient's autoregulation, as further described below.

[0044] In certain embodiments, the controller 16 may utilize a LMS regression method to determine a LMS regression line 64 indicative of a linear correlation between the oxygen saturation measurements 54 plotted against the blood pressure measurements 56. Indeed, as illustrated within the first graph 52, the LMS regression line 64 may be less susceptible to the outliers 62 than a typical LS regression method that existing systems may use to determine a LS regression line 66. Likewise, as illustrated in the second graph 58, the controller 16 may utilize the LMS regression method to determine a LMS regression line 68 between the blood volume measurements 60 plotted against the blood pressure measurements 56, where the LMS regression line 68 is indicative of HVx. As noted above, the LMS regression line 68 may be less susceptible to outliers 62 than a typical LS regression line 70 that may be used by existing systems. In this manner, the controller 16 may ignore or exclude outliers 62 representative of noise or low quality measurements and utilize the remaining measurements to determine the LMS regression lines 64, 68.

[0045] Further, in certain embodiments, the controller 16 may receive signal quality metrics associated with the oxygen saturation signal 46, the blood volume signal 44, and/or the blood pressure signal 48, and may utilize the

signal quality metrics to determine and/or exclude portions of the measurements (e.g., outliers 62). The quality metric may be indicative of the accuracy of the signal and may be calculated based on one or more signal quality indicators. Any suitable signal quality indicators may be considered, including a signal measure indicative of a low light level; a signal measure indicative of an arterial pulse shape; a signal measure indicative of the high frequency signal component in the measured value; a signal measure indicative of a consistency of a pulse shape; a signal measure indicative of an arterial pulse amplitude; and a signal measure indicative of a period of an arterial pulse, for example. These various indicators provide an indirect assessment of the presence of known error sources in blood pressure or oxygen saturation values, which include optical interference between the sensor and the tissue location, physical movement of the patient, and/or improper tissue-to-sensor positioning, for example. Accordingly, the controller 16 may be configured to exclude specific portions of the measurements and/or set a predetermined number of outliers 62 to be excluded based on one or more quality metrics related to the received physiological values. Further, the remaining measurements may be utilized to determine the LMS regression lines 64, 68.

[0046] In certain embodiments, other types of regression methods may be utilized to determine regression lines that are more robust and less susceptible to outliers 62. For example, a least trimmed squares method (LTS) may be used to exclude one or more specific portions of the measurements and/or a predetermined number of outliers 62. Accordingly, the LTS method may be used to fit the remaining measurements that are a more reliable indicator of the patient's physiological condition, and therefore a more reliable indicator of the patient's autoregulation status. Accordingly, the controller 16 may be configured to apply a least median of squares (LMS) regression method or a least trimmed squares (LTS) regression method to measurements to determine the COx or HVx. Indeed, COx or HVx calculated using the LMS regression or the LTS regression methods may have less variability due to signal noise and may be less susceptible to data outliers, as further described with respect to FIGS. 4A and 4B.

[0047] The result of the linear correlation may be the regression lines 64, 66, 68, and 70 between the physiological measurements, and the slope of the regression lines 64, 66, 68, and 70 may be indicative of the patient's autoregulation status. In certain situations, the slope of the regression lines 64, 66, 68, and 70 may also be known as the polarity of the calculated COx or HVx. For example, the slope and/or polarity of the LMS regression line 64 is negative and, thus, the COx value is between -1 and 0, which may indicate proper autoregulation. In such cases, the controller 16 may determine that the patient's cerebral autoregulation is functioning properly and may generate and/or output an appropriate signal indicative of the patient's autoregulation status to the output device 18, for example. However, when the LMS regression line 64 has a positive slope and/or polarity and the COx value is between 0 and 1 or above some predetermined threshold (e.g., 0.1, 0.2, 0.3, 0.4, 0.5, 0.6, 0.7, 0.8 or 0.9, as discussed above), the controller 16 may determine that the patient's autoregulation is impaired and may generate and/or output the appropriate signal indicative of the patient's autoregulation status.

[0048] FIG. 4A is an example of a first graph 72 illustrating a cerebral oximetry index 74 (COx 74) obtained from the first graph 52 of FIG. 3A. In addition, FIG. 4B is an example of a second graph 74 illustrating a hemoglobin volume index 78 (HVx 78) obtained from the second graph 58 of FIG. 3B. The first graph 72 illustrates the COx measure 74 as a continuous signal derived from the oxygen saturation measurements 54 plotted against the blood pressure measurements 56. Specifically, the first graph 72 illustrates a LMS COx measure 80 that may be calculated as a result of applying the LMS regression method to the oxygen saturation measurements 54 and the blood pressure measurements 56. As noted above, linear correlations calculated utilizing the LMS regression method may have less variability due to signal noise and may be less susceptible to outliers 62. Indeed, as illustrated in the first graph 72, the LMS COx measure 80 depicts less variability than a LS COx measure 82 that is derived from a LS regressions method between the oxygen saturation measurements 54 and the blood pressure measurements 56. For example, the LS COx measure 82 may exhibit regions or portions of high variability 84 that may be indicative of unreliable portions of the COx that may be a result of signal noise. Similarly, the second graph 74 illustrates the HVx measure 78 as a continuous signal derived from the blood volume measurements 60 plotted against the blood pressure measurements 56. Specifically, the second graph 74 illustrates a LMS HVx measure 86 that may have less variability due to signal noise and may be less susceptible to outliers 62 than a LS HVx measure 88. As noted above, utilizing the LMS regression method to calculate the LMS HVx measure 86 may help reduce the effect of outliers 62 (e.g., data associated with signal noise), which may otherwise cause regions of high variability 90 within the calculated LS HVx measure 88.

[0049] FIG. 5 is a process flow diagram of a method 100 of monitoring autoregulation based on a confidence metric, in accordance with an embodiment. Some or all of the steps of the method 100 may be implemented by the controller 16 (e.g., the processor 24 of the controller 16) of FIG. 1, for example, to determine whether the patient's autoregulation is impaired and/or to take an appropriate remedial action. In step 102, the controller 16 may receive one or more physiological values, such as, for example, the blood pressure signal 48 (e.g., arterial blood pressure signal), the oxygen saturation signal 46, and/or the blood volume signal 44 from the blood pressure sensor 12 and/or the oxygen saturation sensor 14.

[0050] In step 104, the controller 16 may determine the COx 74 based in part on the linear correlation between blood pressure measurements 56 and the oxygen saturation measurements 54. As noted above, the controller 16 may determine the linear correlation between blood pressure measurements 56 and the oxygen saturation measurements 54 with a least median of squares (LMS) regression. Specifically, the controller 16 may use the LMS regression to determine the LMS regression line 64 that ignores or excludes data outliers 62 representative of noise. Further, as noted above, the controller 16 may calculate the COx based on the slope of the LMS regression line 64. Likewise, in step 106, the controller 16 may determine the HVx based on the linear correlation between blood volume measurements 60 and the blood pressure measurements 56. While in certain embodiments, COx is calculated as an indicator of the patient's autoregulation, in some embodiments, HVx may be calcu-

lated as an indicator of the same. Further still, in certain embodiments, both COx and HVx may be calculated, and one or more of the calculated COx and HVx may be utilized to determine the reliability of the calculated COx or HVx.

[0051] In step 108, the controller 16 may be configured to determine a confidence metric in order to determine the reliability of the calculated COx or HVx. For example, in certain embodiments, the controller 16 may determine and display COx on the output device 18 as an indicator of the patient's autoregulation, and may determine HVx in the background as a confidence metric for the COx. Specifically, the controller 16 may compare the polarity (e.g., slope) of the regression line associated with COx with the polarity (e.g., slope) of the regression line associated with HVx to determine the level of confidence to assign COx, as further described with respect to FIG. 6. For example, if both COx and HVx have a positive polarity (e.g., greater than 0) or if both COx and HVx have a negative polarity (e.g., less than 0), the controller 16 may assign a high level of confidence to COx, and may display COx on the output device 18 as a reliable indicator of the patient's autoregulation. As a further example, when the polarity of COx is negative, the controller 16 may determine that the patient's cerebral autoregulation is intact and functioning properly. Accordingly, if the polarity of HVx is also negative, the controller 16 may determine with a high level of confidence that the patient's cerebral autoregulation is intact. Likewise, in certain embodiments, the controller 16 may determine and display HVx on the output device 18 as an indicator of the patient's autoregulation, and may determine COx in the background as a confidence metric for the HVx.

[0052] In certain embodiments of step 108, the controller 16 may determine a confidence metric based on a combination parameter, which may be calculated as the mean or weighted average of the COx and HVx. Further, the combination parameter may be compared against a pre-determined threshold or value to determine the level of confidence to assign to the COx and/or the HVx. In certain embodiments of step 108, the controller 16 may be configured to determine the confidence metric based on a linear correlation confidence coefficient, which may be calculated by correlating the COx with the HVx. For example, the controller 16 may determine a linear correlation between COx values and HVx values using one or more of the methods described with respect to FIGS. 2-3. Specifically, the controller 16 may be configured to determine a linear correlation confidence coefficient, which may be between -1 and +1, inclusive, where -1 represents total negative correlation, +1 represents total positive correlation, and 0 represents the absence of correlation between the HVx and COx values. Thus, a positive linear correlation confidence coefficient may suggest a high confidence and high reliability in the calculated values, while a negative linear correlation confidence coefficient may suggest a low confidence and reliability.

[0053] In step 110, the controller 16 may be configured to evaluate a confidence level for the COx or HVx. In certain embodiments, the confidence level may be indicated as "high" or "low," while in other embodiments, the confidence level may be associated with a percent confidence, as further described below. If the confidence level is high, the determined COx and/or HVx measures and the associated autoregulation status of the patient is output to the output device 18 in step 112. In some embodiments, information related to

the autoregulation of the patient is displayed on the output device **18**, as further described with respect to FIG. 7. Further, the controller **16** may continue to monitor the patient's autoregulation status by continuing to receive physiological values (step **102**). If the confidence metric is not high (e.g., a low or unacceptable confidence level in the COx and/or the HVx), the controller **16** may take appropriate remedial action in step **114**. For example, the controller **16** may discard the COx and/or may not provide the COx to the output device **18**. In some situations, such as when the currently computed COx value is an average or a weighted average of previously computed COx values, the controller **16** may not use the currently computed COx value in the average or weighted average if the confidence metric is unacceptable. Further, in some situations, if the confidence metric is low or unacceptable, the currently computed COx value may be assigned a lower weighting within the weighted average. In some cases, the controller **16** may cause the output device **18** to display a blank display screen or provide an appropriate visual or audible indication that the COx and/or HVx is unavailable. In certain embodiments, the controller **16** may hold or maintain the COx and/or HVx value immediately preceding the segment determined to be unreliable, and thus may cause the output device **18** to show the most recent reliable COx and/or HVx value for a set period of time (e.g., 5, 10, 20, 30, 40, 50, 60 seconds or more) or until the confidence metric is acceptable. In some embodiments, the controller **16** may be configured to average the unreliable COx and/or HVx value(s) with the most recent reliable COx and/or HVx value(s), and may cause the output device **18** to provide an appropriate visual or audible indication of this average COx and/or HVx value.

[0054] FIG. 6 is a table **120** illustrating example correlations between the COx **74**, the HVx **78**, an autoregulation status **122** of the patient, a vascular reactivity **124** of the patient, and the computed confidence level **126**. As noted above with respect to FIG. 5, in some situations, the controller **16** may determine and display COx on the output device **18** as an indicator of the patient's autoregulation, and may determine HVx in the background as a confidence metric for the COx. Specifically, the controller **16** may compare the polarity (e.g., slope) for COx with the polarity for HVx to determine the confidence level **126** to assign COx. For example, as illustrated in table **120**, if both COx and HVx have a negative polarity (e.g., less than 0), the controller **16** may assign a high confidence level **126** that the calculated COx correlates to an intact autoregulation status **122**. Likewise, if both COx and HVx have a positive polarity (e.g., greater than 0), the controller **16** may assign a high confidence level **126** that the calculated COx correlates to an impaired autoregulation status **122**. In addition, if COx has a positive polarity and HVx has a negative polarity (e.g., opposite polarities), the controller **16** may assign a low confidence level **126** that the calculated COx is impaired. Likewise, if COx has a negative polarity and HVx has a positive polarity, the controller **16** may assign a low confidence level **126** that the calculated COx is intact. In this manner, the controller **16** may determine the reliability of the calculated COx to determine an accurate autoregulation status **122** for monitoring and diagnostic purposes. Furthermore, it should be noted that the controller **16** may determine and display HVx on the output device **18** as an indicator of the patient's autoregulation, and may determine COx in the background as a confidence metric for the HVx.

In these embodiments, the controller **16** may utilize the vascular reactivity **124** of the patient as an indication of the autoregulation status **122** of the patient. Further, the confidence level **126** determined may be provided in a variety of different descriptive ways. For example, in certain embodiments, the confidence level **126** may be presented as a high percent confidence (e.g., 75, 80, 95, or more percent) or a low percent confidence (e.g., 30, 35, 45 or less percent).

[0055] In certain embodiments, the polarity of the COx and/or HVx may be determined in relation to a non-zero threshold. For example, in certain embodiments, the controller **16** may set the threshold to 0.2, so that a positive polarity is any value greater than 0.2 and a negative correlation is any value less than 0.2. It should be noted that any number may be designated as the non-zero threshold. In addition, in certain embodiments, the table **120** may be adapted for correlations between the combination parameter (e.g., mean or weighted average of the COx and HVx) and the autoregulation status **122** and vascular reactivity **124** of the patient. Likewise, in certain embodiments, the table **120** may be adapted for correlations between the linear correlation confidence coefficient (e.g., mean or weighted average of the COx and HVx) and the autoregulation status **122** and vascular reactivity **124** of the patient.

[0056] FIG. 7 is an embodiment of a display **130** of the output device **18** that is configured to display various information related to monitoring the autoregulation of a patient. As illustrated in FIG. 7, the display **130** may include a correlation window **132** that incrementally scans the first graph **72** and/or the second graph **74** to determine a continuous COx **74** and/or a continuous HVx **78**, as illustrated in the third graph **134** and fourth graph **136**, respectively. The resulting continuous COx **74** and/or HVx **78** may also be provided on the display **130**, which may be updated continuously or at predetermined intervals. In particular, the controller **16** may initially set the correlation window **132** to a predetermined period, such as at approximately 300 seconds. In certain embodiments, such as in situations where the controller **16** evaluates a low confidence level **126** of the calculated COx or HVx, the controller **16** may be configured to dynamically vary the period of the correlation window **132** to compute or recompute the COx **74** and/or HVx **78**. For example, the controller **16** may vary the correlation window **132** to have a period of 100 seconds, 150 seconds, 200 seconds, 250 seconds, 350 seconds, 400 seconds, and so forth, when incrementally scanning and calculating the continuous COx **74** and HVx **78** measures. It should be noted that varying the correlation window **132** in this manner may allow the controller **16** to find the correlation window **132** with the particular period that reduces the variability in the calculated COx or HVx caused by signal noise.

[0057] In certain embodiments, an operator may input or select, such as through a first user input **138** disposed on the display **130**, a desired correlation window period **138**, and the controller **16** may calculate the COx **74** and/or HVx **78** by incrementally scanning the first and second graphs **72**, **74** based on the user input. Further, in certain embodiments, the operator may instruct the controller **16**, such as through a second user input **140** disposed on the display **130**, to dynamically smooth or vary the correlation window period **140** in order to reduce the influence of data caused by noise or low quality measurements on the calculated COx **74** and/or HVx **78**. In particular, varying the period of the

correlation window 132 may help to ignore or exclude data that causes high variability within the COx 74 and/or HVx 78, as further described with respect to FIGS. 8A-8F.

[0058] As shown, the display 130 may also be configured to provide a COx value 142 and/or an HVx value 144, which may be updated continuously or at predetermined intervals based on the continuous COx 74 and/or HVx 78 measures. In some embodiments, the display 130 may provide an indication of the confidence level 126 related to whether the COx and/or HVx values 142, 144 and COx and/or HVx values 74, 78 are reliable, which may be determined based on a confidence metric, as discussed above. For example, in the illustrated embodiment, the display 130 indicates that the confidence level 126 is high (e.g., 75, 95, 99 percent confident, or the like), and that the autoregulation status 122 and vascular reactivity status 124 of the patient are impaired. As noted above, the COx value 142 of 0.8 and an HVx value 144 of 0.5 may indicate an impaired autoregulation status 122 and an impaired vascular reactivity status 124. Further, a comparison of the COx value 142 of 0.8 and an HVx value 144 of 0.5 may indicate a positive polarity for both, resulting in the high confidence level 126, and thus the display 130 may be configured to provide a reliable indication of the patient's autoregulation status.

[0059] FIGS. 8A-8F illustrates embodiments of graphs depicting the HVx 78 as it varies between correlation windows 132 having different periods (e.g., window lengths). Specifically, as noted above, the correlation window 132 may have a period of 100 seconds, 150 seconds, 200 seconds, 250 seconds, 300 seconds, 350 seconds, 400 seconds, and so forth. In certain embodiments, the controller 16 may compute the COx 74 and/or HVx 78 across a correlation window 132 having a period of 300 seconds. In some situations, the controller 16 may dynamically vary the correlation window 132 to compute several different COx 74 and/or HVx 78 measures. Specifically, varying the correlation window 132 may smooth or exclude one or more portions of the data to reduce the variability in the calculated COx or HVx caused by signal noise. In certain embodiments, the controller 16 may vary the correlation window 132 to identify a stable region within the COx or HVx that may be a reliable indication of the patient's autoregulation status.

[0060] With the foregoing in mind, FIG. 8A illustrates a graph 150 depicting the HVx 78 calculated over a first correlation window 152 having a period of 100 seconds, FIG. 8B illustrates a graph 153 depicting the HVx 78 calculated over a second correlation window 154 having a period of 200 seconds, FIG. 8C illustrates a graph 155 depicting the HVx 78 calculated over a third correlation window 156 having a period of 250 seconds, FIG. 8D illustrates a graph 157 depicting the HVx 78 calculated over a fourth correlation window 158 having a period of 300 seconds, FIG. 8E illustrates a graph 159 depicting the HVx 78 calculated over a fifth correlation window 160 having a period of 350 seconds, and FIG. 8F illustrates a graph 161 depicting the HVx 78 calculated over a sixth correlation window 162 having a period of 400 seconds. In particular, as illustrated with FIGS. 8A-8F, the variability 90 decreases as the period of the correlation windows 132 increases from 100 seconds to 400 seconds. In this manner, in certain embodiments, the controller 16 may be configured to calculate the correlation window 132 for one or more periods, and may choose the most appropriate correlation window

132 based on the variability of the HVx within each correlation window 132. For example, as illustrated in the series of graphs 150, 153, 155, 157, 159, and 161, the controller 16 may be configured to evaluate the patient's autoregulation based on the HVx 78 determined from the sixth correlation window 162, since the period of the sixth correlation window 162 reduces the variability of the HVx 78 caused by signal noise.

[0061] In certain embodiments, the controller 16 may determine the appropriate period for the correlation window 132 based on one or more quality metrics received from the physiological values. For example, as noted above, the controller 16 may receive signal quality metrics associated with the oxygen saturation signal 46, the blood volume signal 44, and/or the blood pressure signal 48, and may utilize the signal quality metrics to determine and/or exclude portions of the data associated with signal noise. Accordingly, in certain embodiments, the controller 16 may determine the period of the correlation window 16 based on one or more signal quality metrics of the physiological values, such as the shape of the signal.

[0062] FIG. 9 is a process flow diagram of a method 170 for monitoring autoregulation of a patient based on dynamically or manually varying the period of the correlation window 132. Some or all of the steps of the method 170 may be implemented by the controller 16 (e.g., the processor 24 of the controller 16) of FIG. 1, for example, to determine the autoregulation status of the patient based on a reliable COx 74 and/or HVx 78. In step 172, the controller 16 may receive one or more physiological values, such as, for example, the blood pressure signal 48 (e.g., arterial blood pressure signal), the oxygen saturation signal 46, and/or the blood volume signal 44 from the blood pressure sensor 12 and/or the oxygen saturation sensor 14. In step 174, the controller 16 may dynamically vary the period of the correlation window 132 between one or more different periods (e.g., 100 seconds, 150 seconds, 200 seconds, 250 seconds, 350 seconds, 400 seconds, and so forth). In step 176, the controller 16 may compute the COx 74 and/or the HVx 78 for each period of the correlation window 132. For example, the controller 16 may dynamically vary the period of the correlation window 132 to calculate one or more HVx 78 or COx 74 measures, and may select an appropriate index based on the detected variability or stability. Further, in certain embodiments, an operator may select the period of the correlation window 132 based on visually inspecting one or more parameters related to autoregulation displayed on the display 130. Accordingly, in step 178, the controller 16 may determine one or more periods of the correlation window 132 that reduces variability in the calculated COx 74 and/or HVx 78 that may be caused by noise or low quality measurements. The controller 16 may be configured to determine the autoregulation status of a patient based on the COx 74 and/or HVx 78 calculated from a selected window.

[0063] While the disclosure may be susceptible to various modifications and alternative forms, specific embodiments have been shown by way of example in the drawings and have been described in detail herein. However, it should be understood that the embodiments provided herein are not intended to be limited to the particular forms disclosed. Rather, the various embodiments may cover all modifications, equivalents, and alternatives falling within the spirit and scope of the disclosure as defined by the following appended claims. Further, it should be understood that

certain elements of the disclosed embodiments may be combined or exchanged with one another.

What is claimed is:

1. A method for monitoring autoregulation of a patient, comprising:

using a processor for:

- receiving a blood pressure signal, a regional oxygen saturation signal, and a blood volume signal from the patient;
- determining a first linear correlation between the blood pressure signal and the regional oxygen saturation signal;
- determining a second linear correlation between the blood pressure signal and the blood volume signal;
- determining a confidence level associated with the first linear correlation based at least in part on the second linear correlation; and
- providing a signal indicative of the patient's autoregulation status to an output device based on the first linear correlation and the confidence level.

2. The method of claim 1, comprising comparing the first linear correlation to the second linear correlation to determine the confidence level.

3. The method of claim 1, comprising comparing a first polarity of the first linear correlation to a second polarity of the second linear correlation to determine the confidence level.

4. The method of claim 3, comprising providing a cerebral oximetry index value to the output device when both the first and second polarities are positive or when both the first and second polarities are negative.

5. The method of claim 1, comprising determining the confidence level associated with the first linear correlation based at least in part on a combination metric, wherein the combination metric is an average or a weighted average of the first and second linear correlations.

6. The method of claim 1, comprising determining the confidence level associated with the first linear correlation based at least in part on a linear correlation coefficient, and wherein the linear correlation coefficient is based on a third correlation between the first linear correlation and the second linear correlation.

7. The method of claim 1, wherein a least median of squares regression method or a least trimmed squares regression method is used to determine the first and second linear correlations.

8. The method of claim 7, wherein the least median of squares regression method or the least trimmed squares regression method exclude portions of the blood pressure signal, the regional oxygen saturation signal, or the blood volume signal associated with signal noise.

9. The method of claim 1, comprising determining the first linear correlation between the blood pressure signal and the oxygen saturation signal over a correlation window having a first period.

10. The method of claim 9, comprising varying the first period of the correlation window to reduce variability associated with signal noise within the first linear correlation.

11. A monitor for monitoring autoregulation of a patient, comprising:

a memory storing instructions for:

- receiving a blood pressure signal, a regional oxygen saturation signal, and a blood volume signal from the patient;

- determining a first linear correlation between the blood pressure signal and the regional oxygen saturation signal;

- determining a second linear correlation between the blood pressure signal and the blood volume signal;
- determining a confidence level associated with the first linear correlation based at least in part on the second linear correlation; and

- providing a signal indicative of the patient's autoregulation status to an output device based on the first linear correlation and the confidence level; and

a processor configured to execute the instructions.

12. The monitor of claim 11, wherein the memory stores instructions for determining the first and second linear correlations utilizing a least median of squares regression method or a least trimmed squares regression method.

13. The monitor of claim 11, wherein the memory stores instructions for comparing a first polarity of the first linear correlation to a second polarity of the second linear correlation to determine the confidence level.

14. The monitor of claim 13, wherein the memory stores instructions for providing a cerebral oximetry index value to the output device when both the first and second polarities are positive or when both the first and second polarities are negative.

15. The monitor of claim 11, wherein the memory stores instructions for determining the first linear correlation between the blood pressure signal and the regional oxygen saturation signal over a correlation window having a first period.

16. The monitor of claim 15, wherein the memory stores instructions for varying the first period of the correlation window to reduce variability associated with signal noise within the first linear correlation.

17. A system for monitoring autoregulation of a patient, comprising:

- a regional oxygen saturation sensor configured to obtain a regional oxygen saturation signal from a patient; and
- a monitor comprising:

- a display; and

- a processor configured to:

- receive a blood pressure signal, the regional oxygen saturation signal, and a blood volume signal from the patient;

- determine a first linear correlation between the blood pressure signal and the regional oxygen saturation signal;

- determine a second linear correlation between the blood pressure signal and the blood volume signal;

- determine a confidence level associated with the first linear correlation based at least in part on the second linear correlation; and

- provide a signal indicative of the patient's autoregulation status for display on the display based on the first linear correlation and the confidence level.

18. The system of claim 17, wherein the regional oxygen saturation sensor is configured to obtain the regional oxygen saturation signal, the blood volume signal, and/or the blood pressure signal from the patient.

19. The system of claim 17, wherein the processor is configured to cause display of a cerebral oximetry index value indicative of the patient's autoregulation status, a hemoglobin volume index, the confidence level associated

with the cerebral oximetry index value or the hemoglobin volume index, an indication of the patient's autoregulation status, or any combination thereof.

**20.** The system of claim 17, wherein the processor is configured to cause display of a correlation window having a first period, and wherein the processor is configured to determine the first linear correlation between the blood pressure signal and the regional oxygen saturation signal over the correlation window.

\* \* \* \* \*

|                |   |         |            |
|----------------|---|---------|------------|
| 专利名称(译)        | 监视自动调节时用于降低信号噪声的系统和方法   |         |            |
| 公开(公告)号        | <a href="#">US20160367197A1</a>   | 公开(公告)日 | 2016-12-22 |
| 申请号            | US15/184305   | 申请日     | 2016-06-16 |
| [标]申请(专利权)人(译) | 柯惠有限合伙公司  |         |            |
| 申请(专利权)人(译)    | COVIDIEN LP   |         |            |
| 当前申请(专利权)人(译)  | COVIDIEN LP   |         |            |
| [标]发明人         | ADDISON PAUL S<br>MONTGOMERY DEAN<br>WATSON JAMES N   |         |            |
| 发明人            | ADDISON, PAUL S.<br>MONTGOMERY, DEAN<br>WATSON, JAMES N.  |         |            |
| IPC分类号         | A61B5/00 A61B5/0205 A61B5/145   |         |            |
| CPC分类号         | A61B5/7246 A61B5/14542 A61B5/021 A61B5/14546 A61B5/742 A61B5/0205 A61B5/02007 A61B5/02028 A61B5/02108 A61B5/022 A61B5/0261 A61B5/0295 A61B5/14551 A61B5/14553 A61B5/6803 A61B5/7221 A61B5/7264 A61B5/7282 A61B2505/03 A61B2562/0233 G16H50/20 |         |            |
| 优先权            | 62/181067 2015-06-17 US   |         |            |
| 外部链接           | <a href="#">Espacenet</a> <a href="#">USPTO</a>   |         |            |

摘要(译)

一种用于监测自动调节的方法包括使用处理器从患者接收血压信号，区域氧饱和度信号和血量信号。该方法还包括确定血压信号和区域氧饱和度信号之间的第一线性相关性，以及确定血压信号和血量信号之间的第二线性相关性。该方法还包括至少部分地基于第二线性相关性确定与第一线性相关相关联的置信水平，并基于线性相关性和置信水平向输出装置提供指示患者的自动调节状态的信号。

