



US009808204B2

(12) **United States Patent**  
**LeBoeuf et al.**

(10) **Patent No.:** **US 9,808,204 B2**  
(45) **Date of Patent:** **Nov. 7, 2017**

(54) **NONINVASIVE PHYSIOLOGICAL ANALYSIS USING EXCITATION-SENSOR MODULES AND RELATED DEVICES AND METHODS**

(75) Inventors: **Steven Francis LeBoeuf**, Raleigh, NC (US); **Jesse Berkley Tucker**, Knightdale, NC (US); **Michael Edward Aumer**, Raleigh, NC (US)

(73) Assignee: **Valencell, Inc.**, Raleigh, NC (US)

(\* ) Notice: Subject to any disclaimer, the term of this patent is extended or adjusted under 35 U.S.C. 154(b) by 515 days.

(21) Appl. No.: **13/566,269**

(22) Filed: **Aug. 3, 2012**

(65) **Prior Publication Data**

US 2012/0296184 A1 Nov. 22, 2012

**Related U.S. Application Data**

(63) Continuation of application No. 12/256,793, filed on Oct. 23, 2008, now Pat. No. 8,251,903.  
(Continued)

(51) **Int. Cl.**  
**A61B 5/021** (2006.01)  
**A61B 5/1455** (2006.01)  
(Continued)

(52) **U.S. Cl.**  
CPC ..... **A61B 5/721** (2013.01); **A61B 5/0261** (2013.01); **A61B 5/0295** (2013.01);  
(Continued)

(58) **Field of Classification Search**  
None  
See application file for complete search history.

(56) **References Cited**

U.S. PATENT DOCUMENTS

3,595,219 A 7/1971 Friedlander et al.  
4,240,882 A 12/1980 Ang et al.  
(Continued)

FOREIGN PATENT DOCUMENTS

CN 101212927 A 7/2008  
CN 201438747 U 4/2010  
(Continued)

OTHER PUBLICATIONS

“Warfighter Physiological and Environmental Monitoring: A Study for the U.S. Army Research Institute in Environmental Medicine and the Soldier Systems Center”, Massachusetts Institute of Technology Lincoln Laboratory, Final Report, Nov. 1, 2004, prepared for the U.S. Army under Air Force Contract F19628-00-C-0002; approved for public release.

(Continued)

*Primary Examiner* — Matthew Kremer

(74) *Attorney, Agent, or Firm* — Myers Bigel, P.A.

(57) **ABSTRACT**

Methods and apparatus for qualifying and quantifying excitation-dependent physiological information extracted from wearable sensors in the midst of interference from unwanted sources are provided. An organism is interrogated with at least one excitation energy, energy response signals from two or more distinct physiological regions are sensed, and these signals are processed to generate an extracted signal. The extracted signal is compared with a physiological model to qualify and/or quantify a physiological property. Additionally, important physiological information can be qualified and quantified by comparing the excitation wavelength-dependent response, measured via wearable sensors, with a physiological model.

**10 Claims, 7 Drawing Sheets**

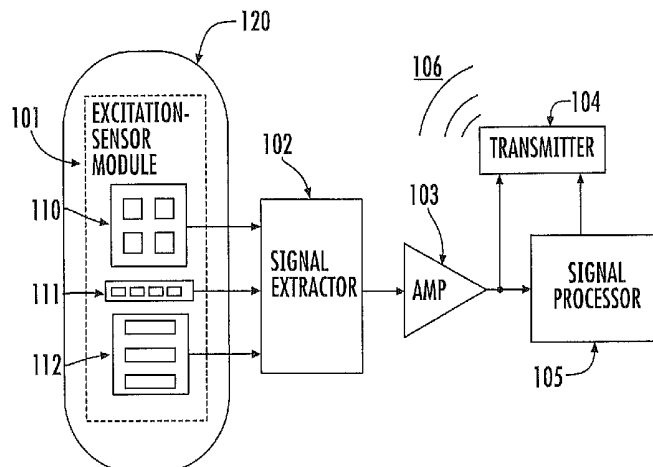

<b>Related U.S. Application Data</b>					
		5,904,654 A	5/1999	Wohltmann et al.	
		5,938,593 A	8/1999	Ouellette	
		5,954,644 A	9/1999	Dettling et al.	
(60)	Provisional application No. 61/000,181, filed on Oct. 25, 2007.	5,964,701 A	10/1999	Asada et al.	
		5,971,931 A	10/1999	Raff	
		5,974,338 A *	10/1999	Asano .....	A61B 5/14535 600/322
(51)	<b>Int. Cl.</b>				
	<i>A61B 5/00</i> (2006.01)	5,995,858 A	11/1999	Kinast	
	<i>A61B 5/026</i> (2006.01)	6,004,274 A	12/1999	Aceti et al.	
	<i>A61B 5/0295</i> (2006.01)	6,006,119 A	12/1999	Soller et al.	
	<i>A61B 5/02</i> (2006.01)	6,013,007 A	1/2000	Root et al.	
	<i>A61B 5/024</i> (2006.01)	6,022,748 A	2/2000	Charych et al.	
	<i>A61B 5/024</i> (2006.01)	6,023,541 A	2/2000	Merchant et al.	
	<i>A61B 6/00</i> (2006.01)	6,030,342 A	2/2000	Amano et al.	
(52)	<b>U.S. Cl.</b>	6,045,511 A	4/2000	Ott et al.	
	CPC .....	6,067,006 A	5/2000	O'Brien	
	<i>A61B 5/02116</i> (2013.01); <i>A61B 5/02141</i> (2013.01); <i>A61B 5/1455</i> (2013.01); <i>A61B 5/14552</i> (2013.01); <i>A61B 5/6815</i> (2013.01); <i>A61B 5/6838</i> (2013.01); <i>A61B 5/021</i> (2013.01); <i>A61B 2562/0233</i> (2013.01); <i>A61B 2562/046</i> (2013.01)	6,070,093 A	5/2000	Oosta et al.	
		6,078,829 A	6/2000	Uchida et al.	
		6,080,110 A	6/2000	Thorgersen	
		6,081,742 A	6/2000	Amano et al.	
		6,122,042 A	9/2000	Wunderman et al.	
		6,148,229 A	11/2000	Morris et al.	
		6,155,983 A	12/2000	Kosuda et al.	
		6,168,567 B1	1/2001	Pickering et al.	
		6,186,145 B1	2/2001	Brown	
		6,198,394 B1	3/2001	Jacobsen et al.	
		6,198,951 B1 *	3/2001	Kosuda et al. ....	600/323
		6,205,354 B1	3/2001	Gellermann et al.	
		6,231,519 B1	5/2001	Blants et al.	
		6,267,721 B1	7/2001	Welles	
		6,283,915 B1	9/2001	Nolan et al.	
		6,285,816 B1	9/2001	Anderson et al.	
		6,289,230 B1	9/2001	Chaiken et al.	
		6,298,314 B1	10/2001	Blackadar et al.	
		6,332,868 B1	12/2001	Sato et al.	
		6,358,216 B1	3/2002	Kraus et al.	
		6,361,660 B1	3/2002	Goldstein	
		6,371,925 B1	4/2002	Imai et al.	
		6,374,129 B1	4/2002	Chin et al.	
		6,415,167 B1	7/2002	Blank et al.	
		6,443,890 B1	9/2002	Schulze et al.	
		6,444,474 B1	9/2002	Thomas et al.	
		6,454,718 B1	9/2002	Clift	
		6,458,080 B1	10/2002	Brown et al.	
		6,470,893 B1	10/2002	Boesen	
		6,513,532 B2	2/2003	Mault et al.	
		6,514,278 B1	2/2003	Hibst et al.	
		6,527,711 B1	3/2003	Stivoric et al.	
		6,527,712 B1	3/2003	Brown et al.	
		6,529,754 B2	3/2003	Kondo	
		6,534,012 B1	3/2003	Hazen et al.	
		6,556,852 B1	4/2003	Schulze et al.	
		6,569,094 B2	5/2003	Suzuki et al.	
		6,571,117 B1	5/2003	Marbach	
		6,605,038 B1	8/2003	Teller et al.	
		6,608,562 B1	8/2003	Kimura et al.	
		6,616,613 B1	9/2003	Goodman	
		6,631,196 B1	10/2003	Taenzer et al.	
		6,647,378 B2	11/2003	Kindo	
		6,656,116 B2	12/2003	Kim et al.	
		6,694,180 B1	2/2004	Boesen	
		6,702,752 B2	3/2004	Dekker	
		6,725,072 B2	4/2004	Steuer et al.	
		6,745,061 B1	6/2004	Hicks et al.	
		6,748,254 B2	6/2004	O'Neil et al.	
		6,760,610 B2	7/2004	Tschupp et al.	
		6,783,501 B2	8/2004	Takahashi et al.	
		6,808,473 B2	10/2004	Hisano et al.	
		6,859,658 B1	2/2005	Krug	
		6,893,396 B2 *	5/2005	Schulze .....	A61B 5/0022 128/903
		6,941,239 B2	9/2005	Unuma et al.	
		6,953,435 B2	10/2005	Kondo et al.	
		6,954,644 B2	10/2005	Johansson et al.	
		6,996,427 B2	2/2006	Ali et al.	
		6,997,879 B1 *	2/2006	Turcott .....	600/507
		7,018,338 B2	3/2006	Vetter et al.	
		7,024,369 B1	4/2006	Brown et al.	
		7,030,359 B2	4/2006	Römhild	
(56)	<b>References Cited</b>				
	<b>U.S. PATENT DOCUMENTS</b>				
	4,281,645 A	8/1981	Jobsis		
	4,331,154 A	5/1982	Broadwater et al.		
	4,438,772 A	3/1984	Slavin		
	4,491,760 A	1/1985	Linville		
	4,521,499 A	6/1985	Switzer		
	4,541,905 A	9/1985	Kuwana et al.		
	4,586,513 A	5/1986	Hamaguri		
	4,592,807 A	6/1986	Switzer		
	4,655,225 A	4/1987	Dahne et al.		
	4,830,014 A	5/1989	Goodman et al.		
	4,882,492 A	11/1989	Schlager		
	4,896,676 A	1/1990	Sasaki		
	4,928,704 A	5/1990	Hardt		
	4,952,890 A	8/1990	Swanson		
	4,952,928 A	8/1990	Carroll et al.		
	4,957,109 A	9/1990	Groeger et al.		
	5,002,060 A	3/1991	Nedivi		
	5,022,970 A	6/1991	Cook et al.		
	5,025,791 A	6/1991	Niwa		
	5,079,421 A	1/1992	Knudson et al.		
	5,080,098 A	1/1992	Willett et al.		
	5,086,229 A	2/1992	Rosenthal et al.		
	5,139,025 A	8/1992	Lewis et al.		
	5,143,078 A	9/1992	Mather et al.		
	5,226,417 A	7/1993	Swedlow et al.		
	5,237,994 A	8/1993	Goldberger		
	5,299,570 A	4/1994	Hatschek		
	5,348,002 A	9/1994	Caro		
	5,377,100 A	12/1994	Pope et al.		
	5,386,819 A	2/1995	Kaneko et al.		
	5,448,082 A	9/1995	Kim		
	5,482,036 A	1/1996	Diab et al.		
	5,492,129 A	2/1996	Greenberger		
	5,494,043 A	2/1996	O'Sullivan et al.		
	5,499,301 A	3/1996	Sudo et al.		
	5,581,648 A	12/1996	Sahagen		
	5,596,987 A	1/1997	Chance		
	5,662,117 A	9/1997	Bittman		
	5,673,692 A	10/1997	Schulze et al.		
	5,697,374 A	12/1997	Odagiri et al.		
	5,711,308 A	1/1998	Singer		
	5,725,480 A *	3/1998	Oosta et al. ....	600/310	
	5,743,260 A	4/1998	Chung et al.		
	5,779,631 A	7/1998	Chance		
	5,797,841 A	8/1998	Delonzor et al.		
	5,807,114 A	9/1998	Hodges et al.		
	5,807,267 A	9/1998	Bryars et al.		
	5,817,008 A	10/1998	Rafert et al.		
	5,820,560 A	10/1998	Sinderby et al.		
	5,846,190 A	12/1998	Woehrle		
	5,853,005 A	12/1998	Scanlon		

(56)

## References Cited

## U.S. PATENT DOCUMENTS

7,034,694 B2	4/2006	Yamaguchi et al.	8,929,965 B2	1/2015	LeBoeuf et al.
7,041,062 B2	5/2006	Friedrichs et al.	8,929,966 B2	1/2015	LeBoeuf et al.
7,043,287 B1	5/2006	Khalil et al.	8,934,952 B2	1/2015	LeBoeuf et al.
7,048,687 B1	5/2006	Reuss et al.	8,942,776 B2	1/2015	LeBoeuf et al.
7,054,674 B2	5/2006	Cane et al.	8,961,415 B2	2/2015	LeBoeuf et al.
7,088,234 B2	8/2006	Naito et al.	9,005,129 B2	4/2015	Venkatraman et al.
7,107,088 B2	9/2006	Aceti	2001/0015123 A1	8/2001	Nishitani et al.
7,113,815 B2	9/2006	O'Neil et al.	2001/0044588 A1	11/2001	Mault
7,117,032 B2	10/2006	Childre et al.	2001/0049471 A1	12/2001	Suzuki et al.
7,163,512 B1	1/2007	Childre et al.	2002/0035340 A1	3/2002	Fraden et al.
7,175,601 B2	2/2007	Verjus et al.	2002/0143242 A1	10/2002	Nemirovski
7,190,986 B1	3/2007	Hannula et al.	2002/0156386 A1	10/2002	Dardik et al.
7,209,775 B2	4/2007	Bae et al.	2002/0156654 A1	10/2002	Roe et al.
7,217,224 B2	5/2007	Thomas	2002/0186137 A1	12/2002	Skardon
7,252,639 B2	8/2007	Kimura et al.	2002/0188210 A1	12/2002	Aizawa
7,263,396 B2	8/2007	Chen et al.	2002/0194002 A1	12/2002	Petrushin
7,289,837 B2	10/2007	Mannheimer et al.	2003/0002705 A1	1/2003	Boesen
7,336,982 B2	2/2008	Yoo et al.	2003/0007631 A1	1/2003	Bolognesi et al.
7,341,559 B2	3/2008	Schultz et al.	2003/0045785 A1	3/2003	Diab et al.
7,376,451 B2	5/2008	Mahony et al.	2003/0050563 A1	3/2003	Suribhotla et al.
7,378,954 B2	5/2008	Wendt	2003/0064712 A1	4/2003	Gaston et al.
7,470,234 B1	12/2008	Elhag et al.	2003/0065257 A1	4/2003	Mault et al.
7,483,730 B2	1/2009	Diab et al.	2003/0065269 A1	4/2003	Vetter et al.
7,486,988 B2	2/2009	Goodall et al.	2003/0083583 A1	5/2003	Kovtun et al.
7,507,207 B2	3/2009	Sakai et al.	2003/0109030 A1	6/2003	Uchida et al.
7,519,327 B2	4/2009	White	2003/0109791 A1*	6/2003	Kondo ..... A61B 5/021 600/500
7,526,327 B2	4/2009	Blondeau et al.	2003/0181795 A1	9/2003	Suzuki et al.
7,583,994 B2	9/2009	Scholz	2003/0181798 A1	9/2003	Al-Ali
7,620,450 B2	11/2009	Kim et al.	2003/0212336 A1	11/2003	Lee et al.
7,625,285 B2	12/2009	Breving	2003/0220584 A1	11/2003	Honeyager et al.
7,652,569 B2	1/2010	Kiff et al.	2003/0222268 A1	12/2003	Yocom et al.
7,689,437 B1	3/2010	Teller et al.	2003/0233051 A1	12/2003	Verjus et al.
7,695,440 B2	4/2010	Kondo et al.	2004/0004547 A1	1/2004	Appelt et al.
7,725,147 B2	5/2010	Li et al.	2004/0022700 A1	2/2004	Kim et al.
7,756,559 B2	7/2010	Abreu	2004/0030581 A1	2/2004	Leven
7,843,325 B2	11/2010	Otto	2004/0034289 A1	2/2004	Teller et al.
7,894,869 B2	2/2011	Hoarau	2004/0034293 A1	2/2004	Kimball
7,914,468 B2	3/2011	Shalon et al.	2004/0039254 A1	2/2004	Stivoric et al.
7,991,448 B2	8/2011	Edgar et al.	2004/0054291 A1	3/2004	Schulz et al.
7,998,079 B2	8/2011	Nagai et al.	2004/0073455 A1	4/2004	McConnochie et al.
8,050,728 B2	11/2011	Al-Ali et al.	2004/0075677 A1	4/2004	Loyall et al.
8,055,319 B2	11/2011	Oh et al.	2004/0077934 A1	4/2004	Massad
8,055,330 B2	11/2011	Egozi	2004/0081621 A1	4/2004	Arndt et al.
8,059,924 B1	11/2011	Letant et al.	2004/0082842 A1	4/2004	Lumba et al.
8,130,105 B2	3/2012	Al-Ali et al.	2004/0097796 A1	5/2004	Berman et al.
8,137,270 B2	3/2012	Keenan et al.	2004/0103146 A1	5/2004	Park
8,157,730 B2	4/2012	LeBoeuf et al.	2004/0117204 A1	6/2004	Mazar et al.
8,172,459 B2	5/2012	Abreu	2004/0120844 A1	6/2004	Tribelsky et al.
8,175,670 B2	5/2012	Baker, Jr. et al.	2004/0122294 A1	6/2004	Hatlestad et al.
8,204,730 B2	6/2012	Liu et al.	2004/0122702 A1	6/2004	Sabol et al.
8,204,786 B2	6/2012	LeBoeuf et al.	2004/0133123 A1	7/2004	Leonhardt et al.
8,233,955 B2	7/2012	Al-Ali et al.	2004/0135571 A1	7/2004	Utela et al.
8,251,903 B2	8/2012	LeBoeuf et al.	2004/0138578 A1	7/2004	Pineda et al.
8,255,027 B2	8/2012	Al-Ali et al.	2004/0158167 A1	8/2004	Smith et al.
8,255,029 B2	8/2012	Addison et al.	2004/0186387 A1	9/2004	Kosuda et al.
8,303,512 B2	11/2012	Kosuda et al.	2004/0186390 A1	9/2004	Ross et al.
8,320,982 B2	11/2012	LeBoeuf et al.	2004/0219056 A1	11/2004	Tribelsky et al.
8,323,982 B2	12/2012	LeBoeuf et al.	2004/0220488 A1	11/2004	Vyshedskiy et al.
8,328,420 B2	12/2012	Abreu	2004/0225207 A1	11/2004	Bae et al.
8,416,959 B2	4/2013	Lott et al.	2004/0228494 A1	11/2004	Smith
8,491,492 B2	7/2013	Shinar et al.	2004/0242976 A1	12/2004	Abreu
8,504,679 B2	8/2013	Spire et al.	2004/0254501 A1	12/2004	Mault
8,506,524 B2	8/2013	Graskov et al.	2005/0004458 A1	1/2005	Kanayama et al.
8,512,242 B2	8/2013	Leboeuf et al.	2005/0007582 A1	1/2005	Villers et al.
8,647,270 B2	2/2014	LeBoeuf et al.	2005/0021519 A1	1/2005	Ghouri
8,652,040 B2	2/2014	LeBoeuf et al.	2005/0027216 A1	2/2005	Guillemaud et al.
8,652,409 B2	2/2014	LeBoeuf et al.	2005/0030540 A1	2/2005	Thornton
8,679,008 B2	3/2014	Hughes et al.	2005/0033200 A1	2/2005	Soehren et al.
8,700,111 B2	4/2014	LeBoeuf et al.	2005/0036212 A1	2/2005	Saito
8,702,607 B2	4/2014	LeBoeuf et al.	2005/0038349 A1	2/2005	Choi et al.
8,730,048 B2	5/2014	Shen et al.	2005/0043600 A1	2/2005	Diab et al.
8,788,002 B2	7/2014	LeBoeuf et al.	2005/0043630 A1	2/2005	Buchert
8,886,269 B2	11/2014	LeBoeuf et al.	2005/0058456 A1	3/2005	Yoo
8,888,701 B2	11/2014	LeBoeuf et al.	2005/0059870 A1	3/2005	Aceti
8,923,941 B2	12/2014	LeBoeuf et al.	2005/0084666 A1	4/2005	Pong et al.
			2005/0100866 A1	5/2005	Arnone et al.
			2005/0101845 A1	5/2005	Nihtila
			2005/0101872 A1	5/2005	Sattler et al.

(56)

## References Cited

## U.S. PATENT DOCUMENTS

2005/0113167	A1	5/2005	Buchner et al.	2007/0191718	A1	8/2007	Nakamura
2005/0113656	A1	5/2005	Chance	2007/0197878	A1	8/2007	Shklarski
2005/0113703	A1	5/2005	Farringdon et al.	2007/0197881	A1	8/2007	Wolf et al.
2005/0116820	A1	6/2005	Goldreich	2007/0213020	A1	9/2007	Novac
2005/0119833	A1	6/2005	Nanikashvili	2007/0230714	A1	10/2007	Armstrong
2005/0148883	A1	7/2005	Boesen	2007/0233403	A1	10/2007	Alwan et al.
2005/0154264	A1	7/2005	Lecompte et al.	2007/0265097	A1	11/2007	Havukainen
2005/0177034	A1	8/2005	Beaumont	2007/0270667	A1	11/2007	Coppi et al.
2005/0187448	A1	8/2005	Petersen et al.	2007/0270671	A1	11/2007	Gal
2005/0187453	A1	8/2005	Petersen et al.	2007/0293781	A1	12/2007	Sims et al.
2005/0192515	A1	9/2005	Givens et al.	2007/0299330	A1	12/2007	Couronne et al.
2005/0196009	A1	9/2005	Boesen	2008/0001735	A1	1/2008	Tran
2005/0203349	A1	9/2005	Nanikashvili	2008/0004536	A1	1/2008	Baxi et al.
2005/0203357	A1*	9/2005	Debreczeny et al. .... 600/323	2008/0015424	A1	1/2008	Bernreuter
2005/0209516	A1	9/2005	Fraden	2008/0039731	A1	2/2008	McCombie et al.
2005/0212405	A1	9/2005	Negley	2008/0076972	A1	3/2008	Dorogusker et al.
2005/0222487	A1	10/2005	Miller et al.	2008/0081963	A1	4/2008	Naghavi et al.
2005/0222903	A1	10/2005	Buchheit et al.	2008/0081972	A1	4/2008	Debreczeny
2005/0228244	A1	10/2005	Banet	2008/0086533	A1	4/2008	Neuhauser et al.
2005/0228299	A1	10/2005	Banet	2008/0096726	A1	4/2008	Riley et al.
2005/0228463	A1	10/2005	Mac et al.	2008/0114220	A1	5/2008	Banet et al.
2005/0240087	A1	10/2005	Keenan et al.	2008/0132798	A1	6/2008	Hong et al.
2005/0245839	A1	11/2005	Stivoric et al.	2008/0133699	A1	6/2008	Craw et al.
2005/0258816	A1	11/2005	Zen et al.	2008/0141301	A1	6/2008	Azzaro et al.
2005/0259811	A1	11/2005	Kimm et al.	2008/0146890	A1	6/2008	LeBoeuf et al.
2006/0009685	A1	1/2006	Finarov et al.	2008/0146892	A1	6/2008	LeBoeuf et al.
2006/0012567	A1	1/2006	Sicklinger	2008/0154098	A1	6/2008	Morris et al.
2006/0063993	A1	3/2006	Yu et al.	2008/0154105	A1	6/2008	Lemay
2006/0064037	A1	3/2006	Shalon et al.	2008/0165017	A1	7/2008	Schwartz
2006/0084878	A1	4/2006	Banet et al.	2008/0170600	A1	7/2008	Sattler et al.
2006/0084879	A1	4/2006	Nazarian et al.	2008/0171945	A1	7/2008	Dotter
2006/0122520	A1	6/2006	Banet et al.	2008/0177162	A1	7/2008	Bae et al.
2006/0123885	A1	6/2006	Yates et al.	2008/0200774	A1	8/2008	Luo
2006/0140425	A1	6/2006	Berg et al.	2008/0203144	A1	8/2008	Kim
2006/0142665	A1	6/2006	Garay et al.	2008/0221461	A1	9/2008	Zhou et al.
2006/0202816	A1	9/2006	Crump et al.	2008/0249594	A1	10/2008	Dietrich
2006/0205083	A1	9/2006	Zhao	2008/0287752	A1	11/2008	Stroetz et al.
2006/0210058	A1	9/2006	Kock et al.	2009/0005662	A1	1/2009	Petersen et al.
2006/0211922	A1	9/2006	Al-Ali et al.	2009/0006457	A1	1/2009	Stivoric et al.
2006/0211924	A1	9/2006	Dalke et al.	2009/0010461	A1	1/2009	Klinghult et al.
2006/0217598	A1	9/2006	Miyajima et al.	2009/0010556	A1	1/2009	Uchibayashi et al.
2006/0224059	A1	10/2006	Swedlow et al.	2009/0030350	A1	1/2009	Yang et al.
2006/0240558	A1	10/2006	Zhao	2009/0054751	A1	2/2009	Babashan et al.
2006/0246342	A1	11/2006	MacPhee	2009/0054752	A1	2/2009	Jonnalagadda et al.
2006/0251277	A1	11/2006	Cho	2009/0069645	A1	3/2009	Nielsen et al.
2006/0251334	A1	11/2006	Oba et al.	2009/0082994	A1	3/2009	Schuler et al.
2006/0252999	A1	11/2006	Devaul et al.	2009/0088611	A1	4/2009	Buschmann
2006/0264730	A1	11/2006	Stivoric et al.	2009/0093687	A1	4/2009	Telfort et al.
2006/0292533	A1	12/2006	Selod	2009/0105548	A1	4/2009	Bart
2006/0293921	A1	12/2006	McCarthy et al.	2009/0105556	A1	4/2009	Fricke et al.
2007/0004449	A1	1/2007	Sham	2009/0112071	A1	4/2009	LeBoeuf et al.
2007/0004969	A1	1/2007	Kong et al.	2009/0112101	A1	4/2009	Furness et al.
2007/0015992	A1	1/2007	Filkins et al.	2009/0131761	A1	5/2009	Moroney, III et al.
2007/0021206	A1	1/2007	Sunnen	2009/0131764	A1	5/2009	Lee et al.
2007/0027367	A1	2/2007	Oliver et al.	2009/0175456	A1	7/2009	Johnson
2007/0027399	A1	2/2007	Chou	2009/0177097	A1	7/2009	Ma et al.
2007/0036383	A1	2/2007	Romero	2009/0214060	A1	8/2009	Chuang et al.
2007/0050215	A1	3/2007	Kil et al.	2009/0221888	A1	9/2009	Wijesiriwardana
2007/0060800	A1	3/2007	Drinan et al.	2009/0227853	A1	9/2009	Wijesiriwardana
2007/0060819	A1	3/2007	Altschuler et al.	2009/0240125	A1	9/2009	Such et al.
2007/0063850	A1	3/2007	Devaul et al.	2009/0253992	A1	10/2009	Van Der Loo
2007/0082789	A1	4/2007	Nissila et al.	2009/0253996	A1	10/2009	Lee et al.
2007/0083092	A1	4/2007	Rippo et al.	2009/0264711	A1	10/2009	Schuler et al.
2007/0083095	A1	4/2007	Rippo et al.	2009/0270698	A1	10/2009	Shioi et al.
2007/0088221	A1	4/2007	Stahmann	2009/0281435	A1	11/2009	Ahmed et al.
2007/0093702	A1	4/2007	Yu et al.	2009/0287067	A1	11/2009	Dorogusker et al.
2007/0106167	A1	5/2007	Kinast	2009/0299215	A1	12/2009	Zhang
2007/0112273	A1	5/2007	Rogers	2010/0004517	A1	1/2010	Bryenton et al.
2007/0112598	A1	5/2007	Heckerman et al.	2010/0022861	A1	1/2010	Cinbis et al.
2007/0116314	A1	5/2007	Grilliot et al.	2010/0045663	A1	2/2010	Chen et al.
2007/0118054	A1	5/2007	Oliver et al.	2010/0100013	A1	4/2010	Hu et al.
2007/0123763	A1	5/2007	Al-Ali et al.	2010/0113948	A1	5/2010	Yang et al.
2007/0135717	A1	6/2007	Uenishi et al.	2010/0168531	A1	7/2010	Shaltis et al.
2007/0165872	A1	7/2007	Bridger et al.	2010/0172522	A1	7/2010	Mooring et al.
2007/0167850	A1	7/2007	Russell et al.	2010/0179389	A1	7/2010	Moroney et al.
				2010/0185105	A1	7/2010	Baldinger
				2010/0217100	A1	8/2010	LeBoeuf
				2010/0217102	A1	8/2010	LeBoeuf et al.
				2010/0217103	A1	8/2010	Abdul-Hafiz et al.

(56)

## References Cited

## U.S. PATENT DOCUMENTS

2010/0222655 A1 9/2010 Starr et al.  
 2010/0228315 A1 9/2010 Nielsen  
 2010/0234714 A1 9/2010 Mercier et al.  
 2010/0268056 A1 10/2010 Picard et al.  
 2010/0274100 A1 10/2010 Behar et al.  
 2010/0274109 A1 10/2010 Hu et al.  
 2010/0292589 A1 11/2010 Goodman  
 2010/0298653 A1 11/2010 McCombie et al.  
 2011/0028810 A1 2/2011 Van Slyke et al.  
 2011/0028813 A1 2/2011 Watson et al.  
 2011/0081037 A1 4/2011 Oh et al.  
 2011/0098112 A1 4/2011 LeBoeuf  
 2011/0105869 A1 5/2011 Wilson et al.  
 2011/0112382 A1 5/2011 Li et al.  
 2011/0130638 A1 6/2011 Raridan, Jr.  
 2011/0142371 A1 6/2011 King et al.  
 2011/0288379 A1 11/2011 Wu  
 2012/0030547 A1 2/2012 Raptis et al.  
 2012/0095303 A1 4/2012 He  
 2012/0156933 A1 6/2012 Kreger et al.  
 2012/0179011 A1 7/2012 Moon et al.  
 2012/0190948 A1 7/2012 Vetter et al.  
 2012/0197093 A1 8/2012 LeBoeuf et al.  
 2012/0203081 A1 8/2012 LeBoeuf et al.  
 2012/0226111 A1 9/2012 LeBoeuf et al.  
 2012/0226112 A1 9/2012 LeBoeuf et al.  
 2012/0277548 A1 11/2012 Burton  
 2013/0053661 A1 2/2013 Alberth et al.  
 2013/0072765 A1 3/2013 Kahn et al.  
 2013/0131519 A1 5/2013 LeBoeuf et al.  
 2013/0245387 A1 9/2013 Patel  
 2013/0336495 A1 12/2013 Burgett et al.  
 2014/0051940 A1 2/2014 Messerschmidt  
 2014/0051948 A1 2/2014 LeBoeuf et al.  
 2014/0052567 A1 2/2014 Bhardwaj et al.  
 2014/0058220 A1 2/2014 LeBoeuf et al.  
 2014/0073486 A1 3/2014 Ahmed et al.  
 2014/0094663 A1 4/2014 LeBoeuf et al.  
 2014/0100432 A1 4/2014 Golda et al.  
 2014/0114147 A1 4/2014 Romesburg et al.  
 2014/0127996 A1 5/2014 Park et al.  
 2014/0128690 A1 5/2014 LeBoeuf et al.  
 2014/0135596 A1 5/2014 LeBoeuf et al.  
 2014/0140567 A1 5/2014 LeBoeuf et al.  
 2014/0171755 A1 6/2014 LeBoeuf et al.  
 2014/0219467 A1 8/2014 Kurtz  
 2014/0235967 A1 8/2014 LeBoeuf et al.  
 2014/0235968 A1 8/2014 LeBoeuf et al.  
 2014/0236531 A1 8/2014 Carter  
 2014/0243617 A1 8/2014 LeBoeuf et al.  
 2014/0243620 A1 8/2014 LeBoeuf et al.  
 2014/0275852 A1 9/2014 Hong et al.  
 2014/0275855 A1 9/2014 LeBoeuf et al.  
 2014/0287833 A1 9/2014 LeBoeuf et al.  
 2014/0288396 A1 9/2014 LeBoeuf et al.  
 2014/0323829 A1 10/2014 LeBoeuf et al.  
 2014/0323830 A1 10/2014 LeBoeuf et al.  
 2014/0323880 A1 10/2014 Ahmed et al.  
 2014/0378844 A1 12/2014 Fei  
 2015/0031967 A1 1/2015 LeBoeuf et al.  
 2015/0032009 A1 1/2015 LeBoeuf et al.  
 2015/0282768 A1 10/2015 Luna et al.  
 2016/0038045 A1 2/2016 Shapiro  
 2016/0287108 A1 10/2016 Wei et al.  
 2017/0034615 A1 2/2017 Mankodi et al.

## FOREIGN PATENT DOCUMENTS

DE 3910749 A1 10/1990  
 EP 1 297 784 A1 4/2003  
 EP 1 480 278 A2 11/2004  
 EP 2 077 091 A2 7/2009  
 EP 2 182 839 B1 10/2011  
 GB 2 408 209 A 5/2005  
 GB 2 411 719 A 9/2005

JP 7-241279 9/1995  
 JP 9-253062 9/1997  
 JP 9-299342 11/1997  
 JP 2000-116611 4/2000  
 JP 2001-025462 1/2001  
 JP 20030159221 6/2003  
 JP 2004-513750 A 5/2004  
 JP 2004-283523 10/2004  
 JP 2005-040261 A 2/2005  
 JP 2005-270544 A 10/2005  
 JP 2007-044203 2/2007  
 JP 2007-185348 7/2007  
 JP 2008-136556 A 6/2008  
 JP 2008-279061 A 11/2008  
 JP 2009-153664 A 7/2009  
 JP 2010-526646 8/2010  
 JP 2014-068733 A 4/2014  
 KR 20-0204510 Y1 11/2000  
 WO WO 00/24064 4/2000  
 WO WO 00/47108 A1 8/2000  
 WO WO 01/08552 A1 2/2001  
 WO WO 02/17782 A2 3/2002  
 WO WO 2005/010568 A2 2/2005  
 WO WO 2005/020121 A1 3/2005  
 WO WO 2005/036212 A2 4/2005  
 WO WO 2005/110238 A1 11/2005  
 WO WO 2006/009830 A2 1/2006  
 WO WO 2006/067690 A2 6/2006  
 WO WO 2007/012931 A2 2/2007  
 WO WO 2007/053146 A1 5/2007  
 WO WO 2008/141306 A2 11/2008  
 WO WO 2011/127063 A1 10/2011  
 WO WO 2013038296 A1 3/2013  
 WO WO 2015/131065 A1 9/2015

## OTHER PUBLICATIONS

Anpo et al. "Photocatalytic Reduction of CO<sub>2</sub> With H<sub>2</sub>O on Titanium Oxides Anchored within Micropores of Zeolites: Effects of the Structure of the Active Sites and the Addition of Pt" *J. Phys. Chem. B*, 101:2632-2636 (1997).  
 Bársan et al. "Understanding the fundamental principles of metal oxide based gas sensors; the example of CO sensing with SnO<sub>2</sub> sensors in the presence of humidity" *Journal of Physics: Condensed Matter* 15:R813-R839 (2003).  
 Bott "Electrochemistry of Semiconductors" *Current Separations* 17(3):87-91 (1998).  
 Colligan, M. J. et al. in "The psychological effects of indoor air pollution", Bulletin of the New York Academy of Medicine, vol. 57, No. 10, Dec. 1981, p. 1014-1026.  
 de Paula Santos, U. et al. in "Effects of air pollution on blood pressure and heart rate variability: a panel study of vehicular traffic controllers in the city of Sao Paulo, Brazil", *European Heart Journal* (2005) 26, 193-200.  
 Ebert, T et al., "Influence of Hydration Status on Thermoregulation and Cycling Hill Climbing," *Med. Sci. Sport Exerc.* vol. 39, No. 2, pp. 323-329, 2007.  
 European Search Report corresponding to European Application No. 07862660.3 dated Apr. 25, 2012; 7 pages.  
 Falkner et al, "Cardiovascular response to mental stress in normal adolescents with hypertensive parents. Hemodynamics and mental stress in adolescents," *Hypertension* 1979, 1:23-30.  
 Fleming et al., "A Comparison of Signal Processing Techniques for the Extraction of Breathing Rate from the Photoplethysmogram," *World Academy of Science, Engineering and Technology*, vol. 30, Oct. 2007, pp. 276-280.  
 Geladas et al., "Effect of cold air inhalation on core temperature in exercising subjects under stress," *The American Physiological Society*, pp. 2381-2387, 1988.  
 Gold, D.R. et al. In "Ambient Pollution and Heart Rate Variability", *Circulation* 2000, 101:1267-1273.  
 International Search Report corresponding to International Patent Application No. PCT/US2012/046446, dated Jan. 14, 2013, 3 pages.  
 International Search Report and Written Opinion of the International Searching Authority, corresponding to PCT/US2012/0948079, dated Oct. 9, 2012.

(56) **References Cited**

## OTHER PUBLICATIONS

- International Search Report and Written Opinion of the International Searching Authority, corresponding to PCT/US2007/025114, dated May 13, 2008.
- International Search Report Corresponding to International Application No. PCT/US2012/022634, dated Aug. 22, 2012, 9 pages.
- Maomao et al., "Mobile Context-Aware Game for the Next Generation," 2<sup>nd</sup> International Conference on Application and Development of Computer Games ADCOG 2003, p. 78-81.
- Martins et al. "Zinc oxide as an ozone sensor" *Journal of Applied Physics* 96(3):1398-1408 (2004).
- Maughan, R.J., "Impact of mild dehydration on wellness and on exercise performance," *European Journal of Clinical Nutrition*, 57, Suppl. 2, pp. S19-S23, 2003.
- Maughan et al., "Exercise, Heat, Hydration and the Brain," *Journal of the American College of Nutrition*, vol. 26, No. 5, pp. 604S-612S, 2007.
- Mostardi, R., et al., "The effect of increased body temperature due to exercise on the heart rate and the maximal aerobic power," *Europ. J. Appl. Physiol*, 33, pp. 237-245, 1974.
- Nakajima et al., "Monitoring of heart and respiratory rates by photoplethysmography using a digital filtering technique," *Med. Eng. Phys.*, vol. 18, No. 5, Jul. 1996, pp. 365-372.
- Notification of Transmittal of the International Search Report and Written Opinion of the International Search Authority dated Jul. 30, 2010 by the Korean Intellectual Property Office for corresponding International Application No. PCT/US2010/021936.
- Notification of Transmittal of the International Search Report and Written Opinion of the International Search Authority dated Aug. 26, 2010 by the Korean Intellectual Property Office for corresponding International Application No. PCT/US2010/021629.
- Notification of Transmittal of the International Search Report and the Written Opinion of the International Search Authority dated Sep. 16, 2010 by the Korean Intellectual Property Office for corresponding International Application No. PCT/US2010/024922.
- Notification of Transmittal of the International Search Report and the Written Opinion of the International Search Authority dated Sep. 27, 2010 by the Korean Intellectual Property Office for corresponding International Application No. PCT/US2010/025216.
- Notification of Transmittal of the International Search Report and the Written Opinion of the International Searching Authority, or the Declaration corresponding to International Application No. PCT/US2013/070271; dated Feb. 26, 2014; 13 pages.
- Saladin et al. "Photosynthesis of CH<sub>4</sub> at a TiO<sub>2</sub> Surface from Gaseous H<sub>2</sub>O and CO<sub>2</sub>" *J. Chem. Soc., Chem. Commun.* 533-534 (1995).
- Shorten et al., "Acute effect of environmental temperature during exercise on subsequent energy intake in active men," *Am. J. Clin. Nutr.* 90, pp. 1215-1221, 2009.
- Skubal et al. "Detection and identification of gaseous organics using a TiO<sub>2</sub> sensor" *Journal of Photochemistry and Photobiology A: Chemistry* 148:103-108 (2002).
- Skubal et al. "Monitoring the Electrical Response of Photoinduced Organic Oxidation on TiO<sub>2</sub> Surfaces" Manuscript submitted Oct. 2000 to SPIE Intl. Symposium on Environment & Industrial Sensing, Boston, MA, Nov. 5-8, 2000, sponsored by SPIE, 10 pp.
- Thompson, M.W., "Cardiovascular drift and critical core temperature: factors limiting endurance performance in the heat?" *J. Exerc. Sci. Fit.*, vol. 4, No. 1, pp. 15-24, 2006.
- Zhang et al. "Development of Chemical Oxygen Demand On-Line Monitoring System Based on a Photoelectrochemical Degradation Principle" *Environ. Sci. Technol.*, 40(7):2363-2368 (2006).
- FitTrainer "The Only Trainer You Need"; <http://itami.com>; Downloaded Feb. 26, 2010; © 2008 FitTrainer™; 2 pages.
- "U.S. Army Fitness Training Handbook" by the Department of the Army, 2003, The Lyons Press. p. 17.
- Edmison et al., "E-Textile Based Automatic Activity Diary for Medical Annotation and Analysis," *Proc. BSN 2006 Int. Workshop Wearable Implantable Body Sensor Netw.* (2006), pp. 131-134, Apr. 3-5, 2006.
- European Search Report, EP Application No. 13863449.8, dated Oct. 19, 2015, 3 pages.
- European Search Report, EP Application No. 14743615.8, dated Oct. 12, 2015, 3 pages.
- European Search Report, EP Application No. 14743839.4, dated Oct. 12, 2015, 3 pages.
- Gibbs et al., "Reducing Motion Artifact in Wearable Bio-Sensors Using MEMS Accelerometers for Active Noise Cancellation," 2005 American Control Conference, Jun. 8-10, 2005, Portland, OR, USA, pp. 1581-1586.
- International Preliminary Report on Patentability, PCT/US2014/012940, dated Jun. 17, 2015, 23 pages.
- International Search Report and Written Opinion of the International Searching Authority, corresponding to International Patent Application No. PCT/US2014/012940, dated Oct. 16, 2014, 13 pages.
- International Search Report corresponding to International Patent Application No. PCT/US2014/012909, dated May 13, 2014, 3 pages.
- Notification Concerning Transmittal of International Preliminary Report on Patentability, PCT/US2014/012909, dated Jul. 28, 2015.
- Notification of Transmittal of the International Search Report and the Written Opinion of the International Searching Authority, or the Declaration, PCT/US2015/014562, dated Oct. 28, 2015.
- Notification of Transmittal of the International Search Report and the Written Opinion of the International Searching Authority, or the Declaration, PCT/US2015/042636, dated Oct. 29, 2015.
- Notification of Transmittal of the International Search Report and the Written Opinion of the International Searching Authority, or the Declaration, PCT/US2015/042015, dated Oct. 29, 2015.
- Notification of Transmittal of the International Search Report and the Written Opinion of the International Searching Authority, or the Declaration, PCT/US2015/042035, dated Oct. 29, 2015.
- Wood et al., "Active Motion Artifact Reduction for Wearable Sensors Using Laguerre Expansion and Signal Separation," Proceedings of the 2005 IEEE Engineering in Medicine and Biology, 27<sup>th</sup> Annual Conference, Shanghai, China, Sep. 1-4, 2005, pp. 3571-3574.
- Notification of Transmittal of the International Search Report and the Written Opinion of the International Searching Authority, or the Declaration, PCT/US2015/046079, dated Dec. 29, 2015.
- Communication pursuant to Article 94(3) EPC, European Patent Application No. 13863449.8, dated Nov. 5, 2015, 7 pages.
- Communication pursuant to Article 94(3) EPC, European Patent Application No. 14743615.8, dated Dec. 23, 2015, 7 pages.
- Communication pursuant to Article 94(3) EPC, European Patent Application No. 14743839.4, dated Dec. 23, 2015, 6 pages.
- Communication pursuant to Article 94(3) EPC, European Patent Application No. 12820308.0, dated Feb. 3, 2016, 5 pages.
- Notification of Transmittal of the International Search Report and Written Opinion of the International Search Authority dated May 26, 2016 by the Korean Intellectual Property Office for corresponding International Application No. PCT/US2016/019126.
- Notification of Transmittal of the International Search Report and Written Opinion of the International Search Authority dated May 26, 2016 by the Korean Intellectual Property Office for corresponding International Application No. PCT/US2016/019132.
- Han et al., "Artifacts in wearable photoplethysmographs during daily life motions and their reduction with least mean square based active noise cancellation method," *Computers in Biology and Medicine*, 42, 2012, pp. 387-393.
- Asada, et al., "Mobile Monitoring with Wearable Photoplethysmographic Biosensors," *IEEE Engineering in Medicine and Biology Magazine*, May/June, 2003, pp. 28-40.
- Bifulco et al., "Bluetooth Portable Device for Continuous ECG and Patient Motion Monitoring During Daily Life," *Medicon 2007, IFMBE Proceedings* 16, 2007, pp. 369-372.
- Brodersen et al., "In-Ear Acquisition of Vital Signs Discloses New Chances for Preventive Continuous Cardiovascular Monitoring," 4<sup>th</sup> International Workshop on Wearable and Implantable Body Sensor Networks (BSN 2007), vol. 13 of the series IFMBE Proceedings, pp. 189-194.

(56)

## References Cited

## OTHER PUBLICATIONS

- Celka et al., "Motion Resistant Earphone Located Infrared based Heart Rate Measurement Device," Proceedings of the Second IASTED International Conference on Biomedical Engineering, Feb. 16-18, 2004, Innsbruck, Austria, pp. 582-585.
- Communication Pursuant to Article 94(3) EPC, EP 12 739 502.8, dated Jul. 19, 2016, 7 pages.
- Communication Pursuant to Article 94(3) EPC, EP 14 743 615.8, dated Jul. 19, 2016, 7 pages.
- Communication Pursuant to Article 94(3) EPC, EP 14 743 839.4, dated Jul. 20, 2016, 5 pages.
- Comtois et al., "A Wearable Wireless Reflectance Pulse Oximeter for Remote Triage Applications," 2006 IEEE, pp. 53-54.
- Comtois, Gary, W., "Implementation of Accelerometer-Based Adaptive Noise Cancellation in a Wireless Wearable Pulse Oximeter Platform for Remote Physiological Monitoring and Triage," Thesis, Worcester Polytechnic Institute, Aug. 31, 2007, 149 pages.
- Duun et al., "A Novel Ring Shaped Photodiode for Reflectance Pulse Oximetry in Wireless Applications," IEEE Sensors 2007 Conference, pp. 596-599.
- Geun et al., "Measurement Site and Applied Pressure Consideration in Wrist Photoplethysmography," The 23<sup>rd</sup> International Technical Conference on Circuits/Systems, Computers and Communications, 2008, pp. 1129-1132.
- Gibbs et al., "Active motion artifact cancellation for wearable health monitoring sensors using collocated MEMS accelerometers," Smart Structures and Materials, 2005: Sensors and Smart Structures Technologies for Civil, Mechanical, and Aerospace Systems, Proc. of SPIE, vol. 5765, pp. 811-819.
- Haahr et al., "A Wearable "Electronic Patch" for Wireless Continuous Monitoring of Chronically Diseased Patients," Proceedings of the 5<sup>th</sup> International Workshop on Wearable and Implantable Body Sensor Networks, in conjunction with the 5<sup>th</sup> International Summer School and Symposium on Medical Devices and Biosensors, The Chinese University of Hong Kong, Hksar, China, Jun. 1-3, 2008, pp. 66-70.
- Jiang, Honghui, "Motion-Artifact Resistant Design of Photoplethysmograph Ring Sensor for Driver Monitoring," Thesis, Massachusetts Institute of Technology, Feb. 2004, 62 pages.
- Kuzmina et al., "Compact multi-functional skin spectrometry set-up," Advanced Optical Materials, Technologies, and Devices, Proc. of SPIE, vol. 6596, 2007, pp. 65960T-1 to 65960T-6.
- Lee et al., "Respiratory Rate Detection Algorithms by Photoplethysmography Signal Processing," 30<sup>th</sup> Annual International IEEE EMBS Conference, Vancouver, British Columbia, Canada, Aug. 20-24, 2008, pp. 1140-1143.
- Lindberg et al., "Monitoring of respiratory and heart rates using a fibre-optic sensor," Med Biol Eng Comput, Sep. 1992, vol. 30, No. 5, pp. 533-537.
- Luprano, Jean, "Sensors and Parameter Extraction by Wearable Systems: Present Situation and Future," pHealth 2008, May 21, 2008, 29 pages.
- Lygouras et al., "Optical-Fiber Finger Photo-Plethysmograph Using Digital Techniques," IEEE Sensors Journal, vol. 2, No. 1, Feb. 2002, pp. 20-25.
- Maguire et al., "The Design and Clinical Use of a Reflective Brachial Photoplethysmograph," Technical Report NUIM/SS/—/2002/04, Submitted Apr. 2002, Signals and Systems Research Group, National University of Ireland, Maynooth, Co. Kildare, Ireland, 13 pages.
- Mendelson et al., "Measurement Site and Photodetector Size Considerations in Optimizing Power Consumption of a Wearable Reflectance Pulse Oximeter," Proceedings of the 25<sup>th</sup> Annual International Conference of the IEEE EMBS, Cancun, Mexico, Sep. 17-21, 2003, pp. 3016-3019.
- Mendelson et al., "Noninvasive Pulse Oximetry Utilizing Skin Reflectance Photoplethysmography," IEEE Transactions on Biomedical Engineering, vol. 35, No. 10, Oct. 1988, pp. 798-805.
- Poh et al., "Motion Tolerant Magnetic Earring Sensor and Wireless Earpiece for Wearable Photoplethysmography," IEEE Transactions on Information Technology in Biomedicine, vol. 14, No. 3, May 2010, pp. 786-794.
- Reuvey et al., "Wrist-Located Pulse Detection Using IR Signals, Activity and Nonlinear Artifact Cancellation," IEEE EMBS, 2001, 4 pages.
- Rhee et al., "Artifact-Resistant Power-Efficient Design of Finger-Ring Plethysmographic Sensors," IEEE Transactions on Biomedical Engineering, vol. 48, No. 7, Jul. 2001, pp. 795-805.
- Shaltis, Phillip Andrew, Analysis and Validation of an Artifact Resistant Design for Oxygen Saturation Measurement Using Photo Plethysmographic Ring Sensors, Thesis, Massachusetts Institute of Technology, Jun. 2004, 103 pages.
- Shin et al., "A Novel Headset with a Transmissive PPG Sensor for Heart Rate Measurement," ICBME 2008, Proceedings 23, 2009, pp. 519-522.
- Spigulis et al., "Wearable wireless photoplethysmography sensors," Proc. of SPIE, vol. 6991, 2008, pp. 699120-1 to 699120-7.
- Takatani et al., "Optical Oximetry Sensors for Whole Blood and Tissue," IEEE Engineering in Medicine and Biology, Jun./Jul. 1994, pp. 347-357.
- Vogel et al., "A System for Assessing Motion Artifacts in the Signal of a Micro-Optic In-Ear Vital Signs Sensor," 30<sup>th</sup> Annual International IEEE EMBS Conference, Vancouver, British Columbia, Canada, Aug. 20-24, 2008.
- Vogel et al., "In-Ear Heart Rate Monitoring Using a Micro-Optic Reflective Sensor," Proceedings of the 29<sup>th</sup> Annual International Conference of the IEEE EMBS Cite Internationale, Lyon, France, Aug. 23-26, 2007, pp. 1375-1378.
- Wang et al., "Multichannel Reflective PPG Earpiece Sensor With Passive Motion Cancellation," IEEE Transactions on Biomedical Circuits and Systems, vol. 1, No. 4, Dec. 2007, pp. 235-241.
- Wang et al., "Reflective Photoplethysmograph Earpiece Sensor for Ubiquitous Heart Rate Monitoring," 4<sup>th</sup> International Workshop on Wearable and Implantable Body Sensor Networks, 2007, vol. 13 of the series IFMBE Proceedings, pp. 179-183.
- Wei et al., "A New Wristband Wearable Sensor Using Adaptive Reduction Filter to Reduce Motion Artifact," Proceedings of the 5<sup>th</sup> International Conference on Information Technology and Application in Biomedicine, in conjunction with the 2<sup>nd</sup> International Symposium & Summer School on Biomedical and Health Engineering, Shenzhen, China, May 30-31, 2008, pp. 278-281.
- Wood, Levi Benjamin, "Motion Artifact Reduction for Wearable Photoplethysmogram Sensors Using Micro Accelerometers and Laguerre Series Adaptive Filters," Thesis, Massachusetts Institute of Technology, Jun. 2008, 74 pages.
- Extended European Search Report, EP Application No. 16164775.5 dated Sep. 13, 2016, 7 pages.
- Notification of Transmittal of the International Search Report and the Written Opinion of the International Searching Authority, or the Declaration, PCT/US2016/041842, dated Oct. 21, 2016, 5 pages.
- Notification of Transmittal of International Preliminary Report on Patentability, PCT/US2015/041562, dated Oct. 20, 2016, 14 pages.
- Notification of Transmittal of International Preliminary Report on Patentability, PCT/US2015/042636, dated Oct. 20, 2016, 7 pages.
- Notification of Transmittal of International Preliminary Report on Patentability, PCT/US2015/042015, dated Oct. 20, 2016, 10 pages.
- Notification of Transmittal of International Preliminary Report on Patentability, PCT/US2015/042035, dated Oct. 20, 2016, 8 pages.
- Notification of Transmittal of International Preliminary Report on Patentability, PCT/US2015/046079, dated Oct. 20, 2016, 10 pages.
- Communication with Supplementary European Search Report corresponding to European Application No. 15830336.2 (8 pages) (dated Jun. 7, 2017).
- Comtois et al., "A Comparative Evaluation of Adaptive Noise Cancellation Algorithms for Minimizing Motion Artifacts in a Forehead-Mounted Wearable Pulse Oximeter" *Proceedings of the 29<sup>th</sup> Annual International Conference of the IEEE EMBS*(pp. 1528-1531) (Aug. 23-26, 2007).

(56)

**References Cited**

OTHER PUBLICATIONS

Han et al. "Development of a wearable health monitoring device with motion artifact reduced algorithm" *International Conference on Control, Automation and Systems 2007 (ICCAS 2007)*(pp. 1581-1584) (Oct. 17-20, 2007).

Lee et al. "A Mobile Care System With Alert Mechanism" *IEEE Transactions on Information Technology in Biomedicine*11(5):507-517 (Sep. 2007).

Webster, John G. "Design of Pulse Oximeters" *Medical Science Series, Institute of Physics Publication*(143 pages) (Aug. 1997).

\* cited by examiner

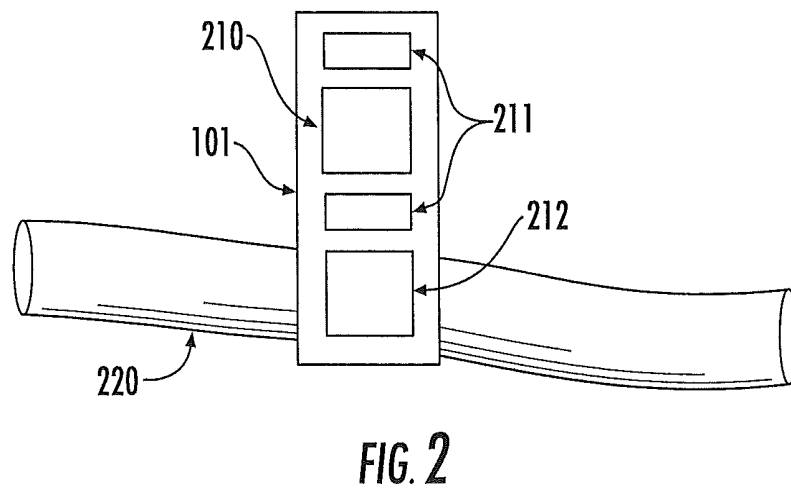
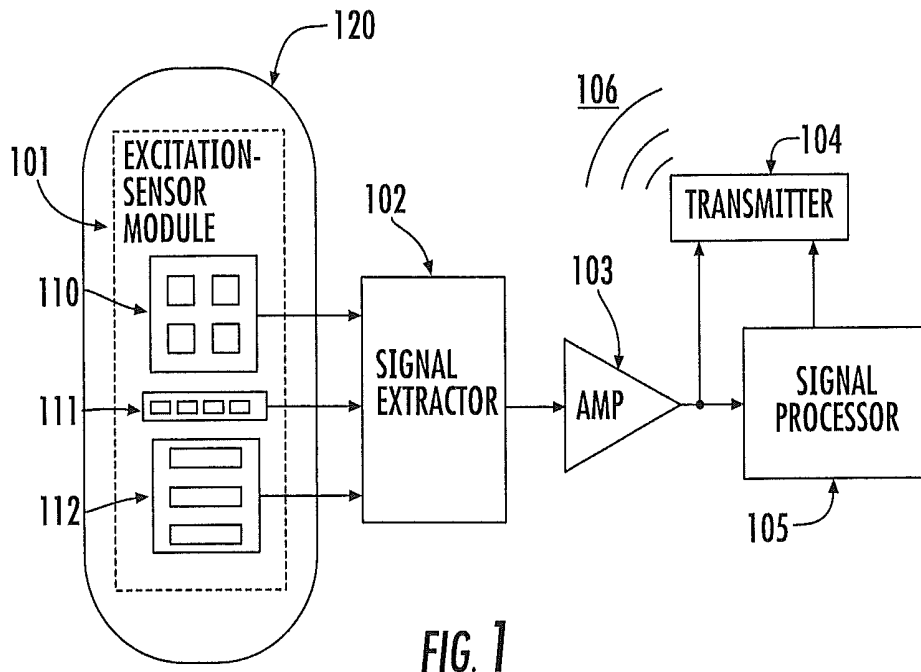

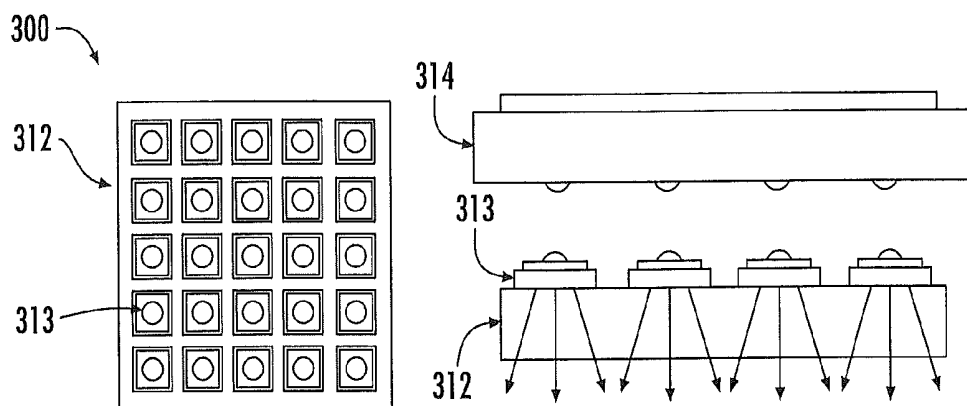

FIG. 3

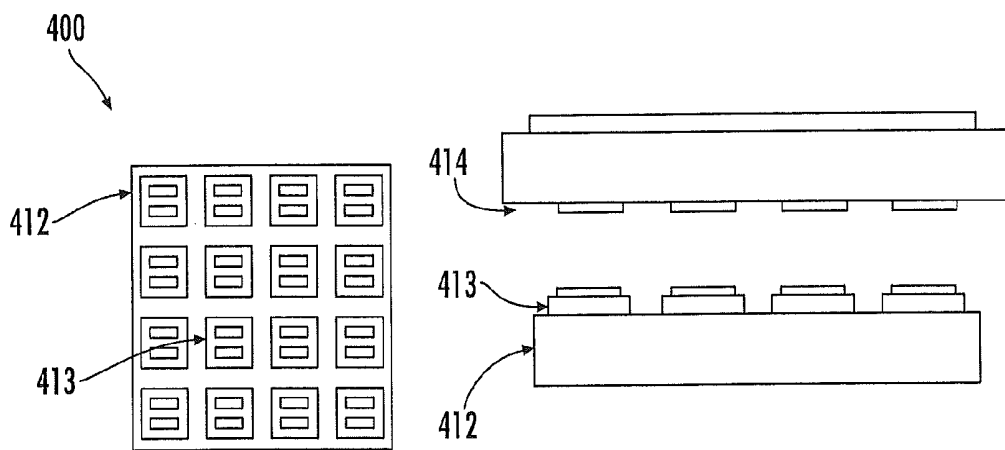

FIG. 4

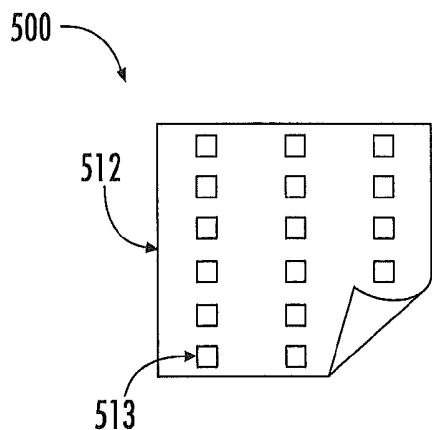

FIG. 5A

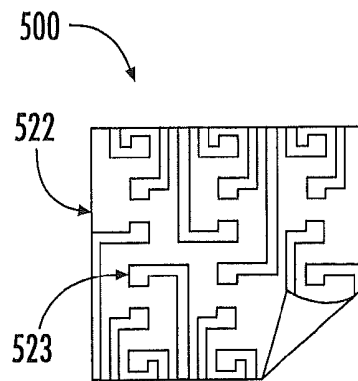

FIG. 5B

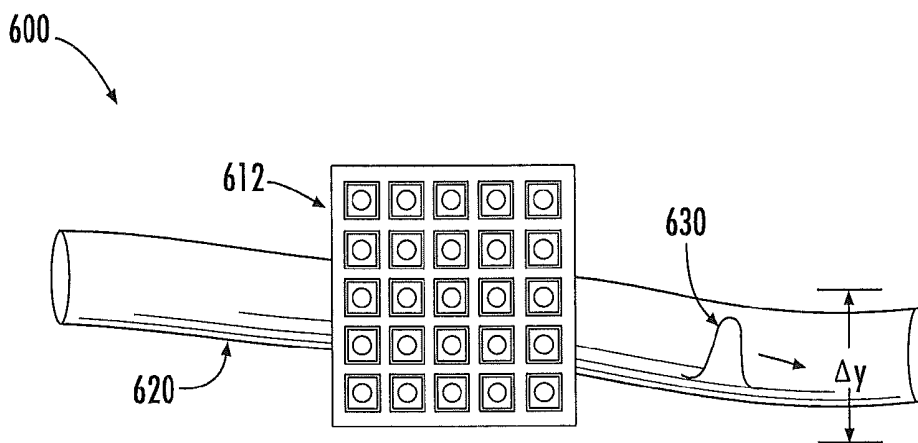

FIG. 6

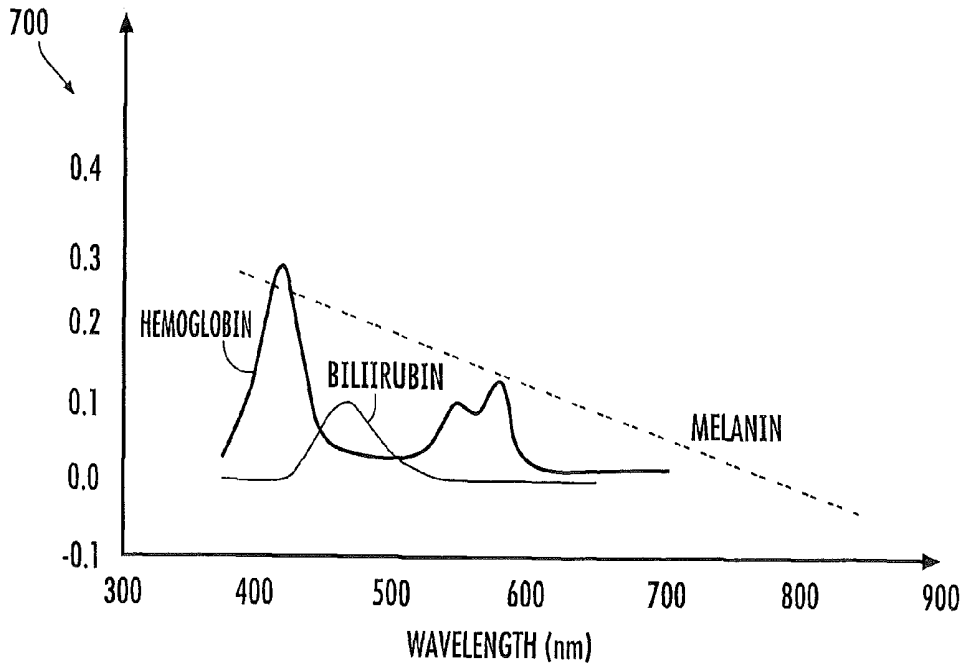

FIG. 7

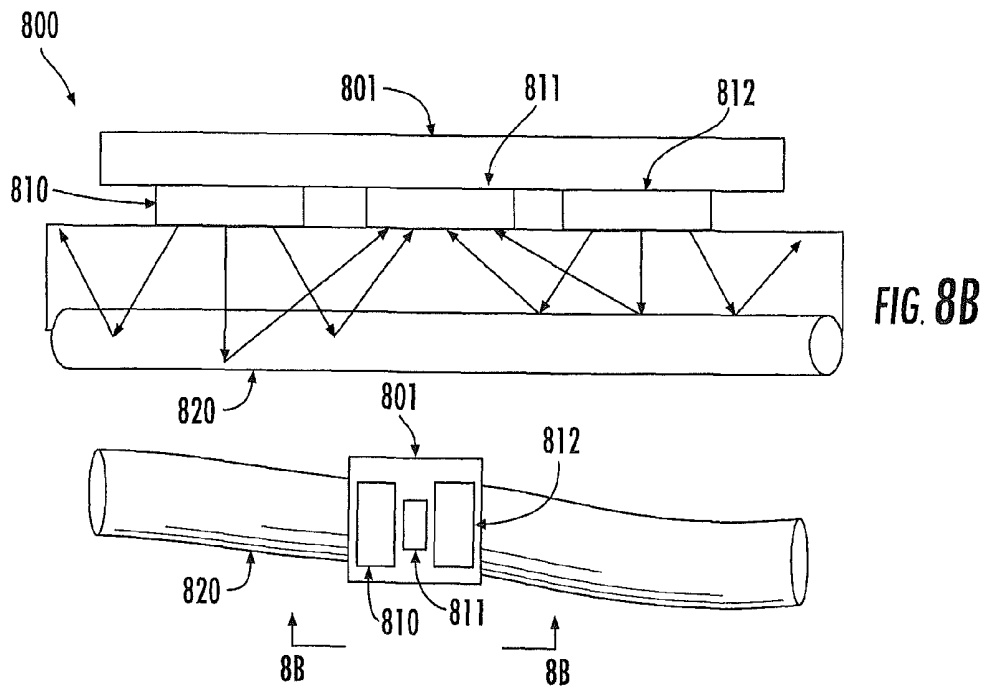

FIG. 8A

FIG. 8B

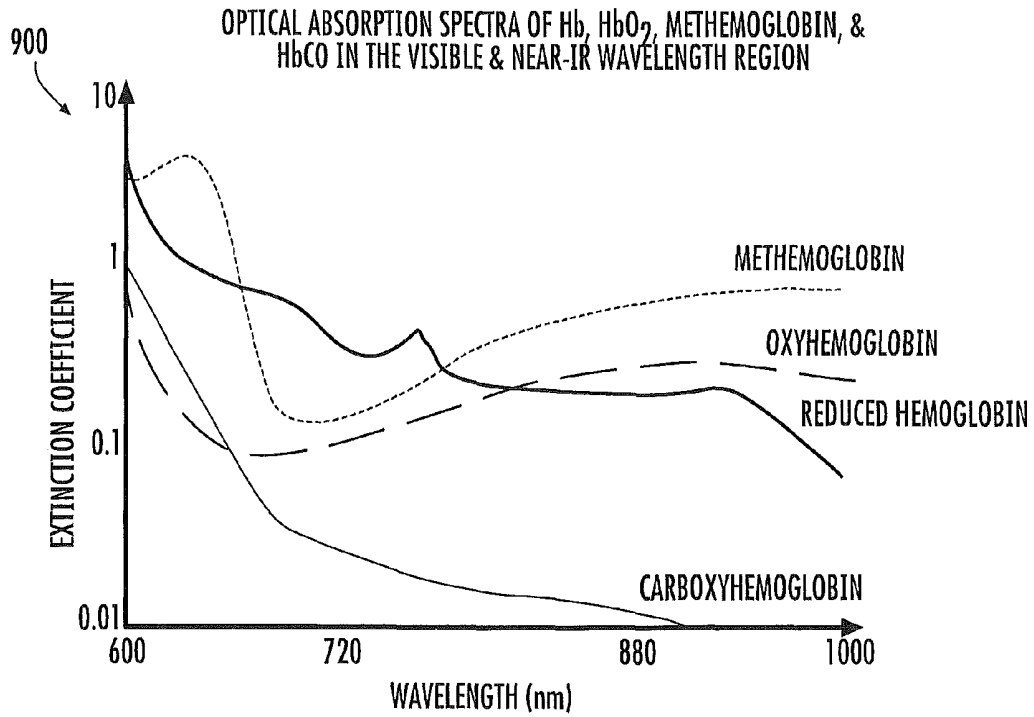

FIG. 9

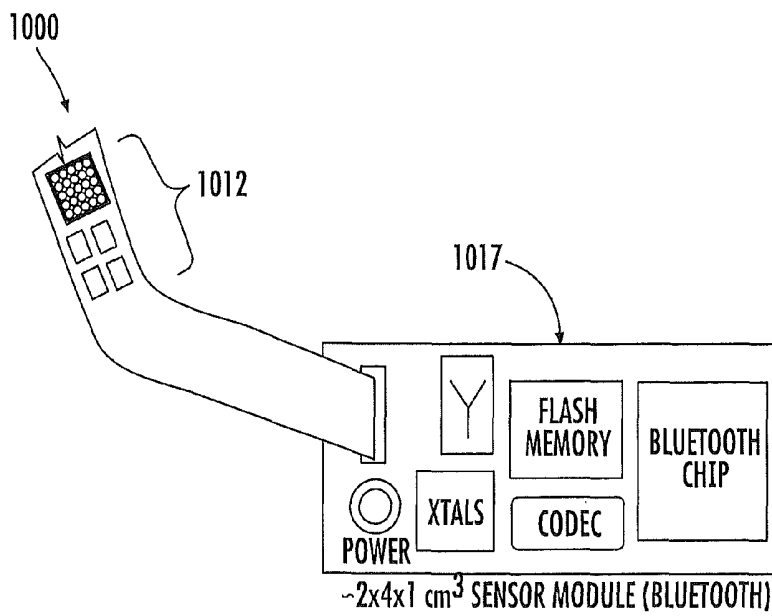

FIG. 10

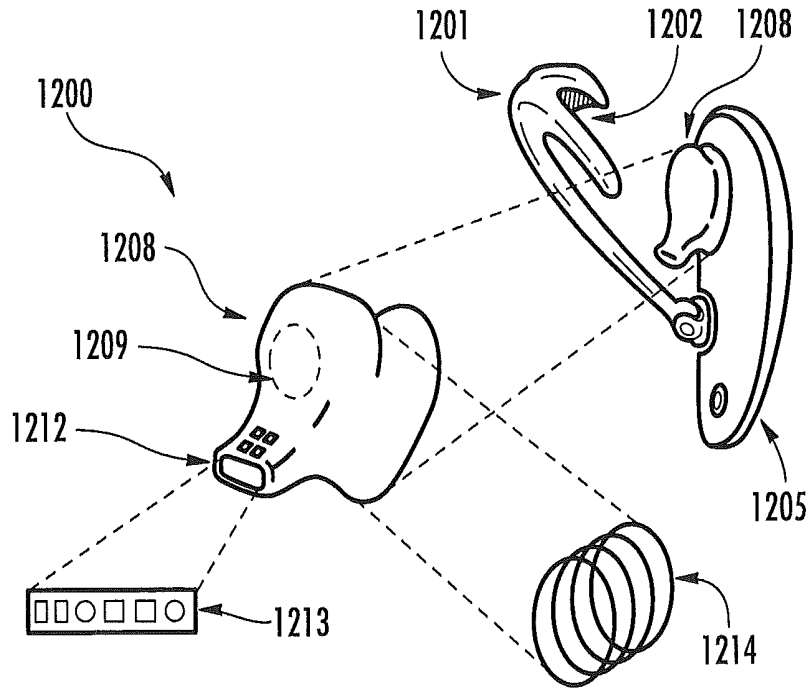

FIG. 11

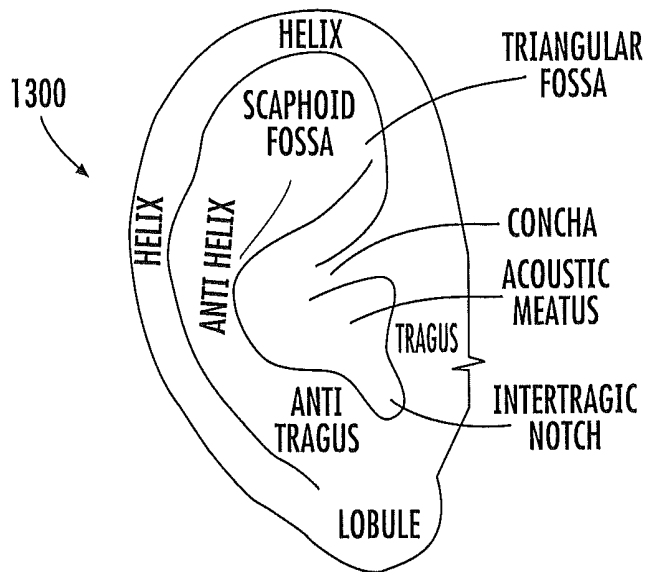

FIG. 12

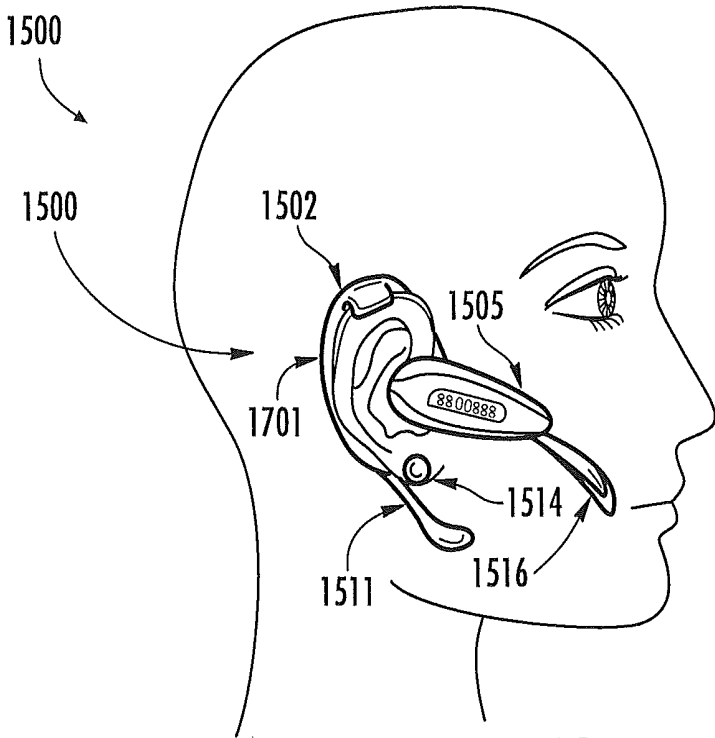

FIG. 13

**NONINVASIVE PHYSIOLOGICAL ANALYSIS  
USING EXCITATION-SENSOR MODULES  
AND RELATED DEVICES AND METHODS**

RELATED APPLICATION

This application is a continuation application of U.S. patent application Ser. No. 12/256,793, filed Oct. 23, 2008 now U.S. Pat. No. 8,251,903, which claims the benefit of and priority to U.S. Provisional Patent Application No. 61/000,181, filed Oct. 25, 2007, the disclosures of which are incorporated herein by reference as if set forth in their entireties.

FIELD OF THE INVENTION

The present invention relates generally to health and, more particularly, to health monitoring.

BACKGROUND OF THE INVENTION

Noninvasive qualification and quantification of physiological properties via wearable sensors may be executed by exciting a physiological region with energy and monitoring the response to that energy with one or more sensors. In wearable pulse oximetry, for example, optical energy from one or more light-emitting diodes (LEDs) excites a region of the body rich with blood vessels (such as a finger tip), and a photodiode senses scattered optical energy relating to blood flow through these blood vessels. Physiological information extracted via such wearable sensor devices may be confounded by a variety of unavoidable factors. Firstly, the extraction of important physiological information may be obscured by unwanted motion artifacts. These motion artifacts may generate false signals that distort physiological information extracted from the wearable sensors. Secondly, the physiological information of interest may be overpowered by unwanted information from neighboring physiological features. For example, pulse oximetry data regarding blood oxygen levels in a blood vessel may be distorted by optical scatter from the skin or blood vessels themselves. Other factors may also confound the physiological information of interest.

SUMMARY

In view of the above discussion, methods and apparatus for qualifying and quantifying excitation-dependent physiological information extracted from wearable sensors in the midst of interference from unwanted sources are provided. According to some embodiments of the present invention, an organism is interrogated with at least one excitation energy, energy response signals from two or more distinct physiological regions are sensed, and these signals are processed to generate an extracted signal. The extracted signal is compared with a physiological model to qualify and/or quantify a physiological property. Additionally, important physiological information can be qualified and quantified by comparing the excitation wavelength-dependent response, measured via wearable sensors, with a physiological model.

According to some embodiments of the present invention, a method of monitoring at least one physiological property (e.g., properties associated with the skin, blood, and/or blood vessels, etc.) of an organism includes directing energy at a target region of the organism; detecting an energy response signal from the target region and an energy

response signal from a region adjacent to the target region; processing the detected signals to produce an extracted energy response signal; and comparing the extracted energy response signal with a physiological model to assess a physiological condition of the organism. Energy directed at a target region may include electromagnetic radiation, mechanical energy, acoustical energy, electrical energy, and/or thermal energy.

Processing the detected signals to produce an extracted energy response signal may include subtracting the energy response signal from the region adjacent to the target region from the energy response signal from the target region. In some embodiments, the energy response signal from the target region and the energy response signal from a region adjacent to the target region may be differentially amplified prior to processing. In some embodiments, the extracted energy response signal may be amplified prior to comparing the extracted signal with a physiological model. The extracted energy response signal may be transmitted (e.g., wirelessly, etc.) to a remote device, such as a computing device, communication device, entertainment device, etc.

According to some embodiments of the present invention, directing energy at a target region of the organism includes directing electromagnetic radiation via one or more optical emitters, such as laser diodes (LDs), light-emitting diodes (LEDs), organic light-emitting diodes (OLEDs), etc. In some embodiments, one or more arrays of optical emitters may be utilized to direct energy at a target region. Monolithic and partially monolithic arrays may be utilized. In some embodiments, optical emitters may be configured to direct electromagnetic radiation at different wavelengths, and the detectors may be configured to detect electromagnetic radiation at different wavelengths.

According to some embodiments of the present invention, detecting an energy response signal from the target region and an energy response signal from a region adjacent to the target region includes detecting via one or more detectors, such as acoustic detectors, auscultatory detectors, motion detectors, optical detectors, thermal detectors, piezoelectric detectors, etc. In some embodiments, one or more arrays of detectors can be utilized.

According to some embodiments of the present invention, an apparatus that monitors at least one physiological property of an organism includes at least one energy emitter configured to direct energy at a target region of the organism; at least one detector configured to detect an energy response signal from the target region and an energy response signal from a region adjacent to the target region; and a processor. The processor is configured to process the detected signals to produce an extracted energy response signal, and to compare the extracted energy response signal with a physiological model to assess a physiological condition (e.g., skin properties, blood flow properties, blood pressure, blood vessel properties, etc.) of the organism. The processor is configured to subtract the energy response signal from the region adjacent to the target region from the energy response signal from the target region to produce an extracted energy response signal. In some embodiments, the processor differentially amplifies the energy response signal from the target region and the energy response signal from a region adjacent to the target region prior to producing the extracted energy response signal. In some embodiments, the processor amplifies the extracted energy response signal prior to comparing the extracted energy response signal with a physiological model to assess a physiological condition of the organism.

Energy emitters that direct electromagnetic radiation, mechanical energy, acoustical energy, electrical energy, and/or thermal energy may be utilized. In some embodiments, the at least one energy emitter comprises one or more optical emitters, such as LDs, LEDs, OLEDs, etc. In some embodiments, at least one array of optical emitters are utilized to direct energy at a target region. Monolithic and partially monolithic arrays may be utilized. In some embodiments, optical emitters may be configured to direct electromagnetic radiation at different wavelengths, and the detectors may be configured to detect electromagnetic radiation at different wavelengths.

Detectors utilized to detect an energy response signal from the target region and an energy response signal from a region adjacent to the target region may include auscultatory detectors, motion detectors, optical detectors, thermal detectors, piezoelectric detectors, etc. In some embodiments, one or more arrays of detectors can be utilized. In some embodiments, one or more detectors are utilized to detect an energy response signal from the target region and one or more other detectors are utilized to detect an energy response signal from a region adjacent to the target region. For example, at least one array of detectors may be utilized to detect an energy response signal from the target region and at least one array of detectors may be utilized to detect an energy response signal from a region adjacent to the target region.

Apparatus according to some embodiments of the present invention may include a transmitter in communication with the processor that is configured to transmit (e.g., wirelessly, etc.) the extracted energy response signal to a remote computing device, communication device, and/or entertainment device.

According to other embodiments of the present invention, wearable apparatus for monitoring at least one physiological property of an organism are provided. For example, a wearable apparatus includes a housing configured to be worn by the organism; at least one energy emitter attached to the housing that is configured to direct energy at a target region of the organism; at least one detector attached to the housing that is configured to detect an energy response signal from the target region and an energy response signal from a region adjacent to the target region; and a processor attached to the housing. The processor is in communication with the at least one detector and is configured to process detected signals to produce an extracted energy response signal, and to compare the extracted energy response signal with a physiological model to assess a physiological condition of the organism. In some embodiments, the wearable apparatus is an earpiece that is configured to be attached to an ear of the organism.

According to other embodiments of the present invention, an apparatus that monitors at least one physiological property of an organism includes a processor, and one or more optical emitters configured to direct electromagnetic radiation at a target region of the organism. The optical emitters are configured to be electrically biased by the processor so as to detect an energy response signal from the target region and an energy response signal from a region adjacent to the target region. The processor is configured to process the detected signals to produce an extracted energy response signal, and to compare the extracted energy response signal with a physiological model to assess a physiological condition of the organism.

#### BRIEF DESCRIPTION OF THE DRAWINGS

FIG. 1 is a block diagram of a device for noninvasively monitoring a physical property of an organism, according to some embodiments of the present invention.

FIG. 2 illustrates the excitation-sensor module of FIG. 1 aligned over a physiological region of interest.

FIG. 3 illustrates an excitation-sensor module comprising a monolithic array of optical emitters operating as emitters or detectors depending on the electrical bias, according to some embodiments of the present invention.

FIG. 4 illustrates an excitation-sensor module comprising an array of piezoelectric sensors operating as both mechanical energy generators as well as mechanical energy sensors depending on the electrical bias, according to some embodiments of the present invention.

FIGS. 5A-5B illustrate flexible piezoelectric arrays that may be utilized in accordance with embodiments of the present invention.

FIG. 6 illustrates an excitation-sensor array, according to some embodiments of the present invention, being used to qualify and/or quantify physiological properties of a blood vessel and/or blood, such as blood pressure or metabolic status of the blood.

FIG. 7 is a graph that illustrates the spectral reflectance response of, melanin, bilirubin, and hemoglobin.

FIG. 8A is a top plan view of a device for exciting at least one region with multiple wavelengths of electromagnetic radiation and sensing the response related to each wavelength for comparison with a physiological model, according to some embodiments of the present invention.

FIG. 8B is side elevation view of the device of FIG. 8A, taken along lines 8B-8B.

FIG. 9 is a graph that illustrates the spectral extinction coefficient of various forms of hemoglobin.

FIG. 10 is a block diagram of a wearable telemetric device, according to some embodiments of the present invention.

FIG. 11 is an exploded perspective view of a telemetric hands-free audio headset capable of both telemetric personal communications and/or entertainment and physiological monitoring, that can be utilized to implement various embodiments of the present invention.

FIG. 12 illustrates the anatomy of the human ear.

FIG. 13 illustrates the hands-free headset of FIG. 11 being worn by a person.

#### DETAILED DESCRIPTION

The present invention now is described more fully hereinafter with reference to the accompanying drawings, in which preferred embodiments of the invention are shown. This invention may, however, be embodied in many different forms and should not be construed as limited to the embodiments set forth herein; rather, these embodiments are provided so that this disclosure will be thorough and complete, and will fully convey the scope of the invention to those skilled in the art.

Like numbers refer to like elements throughout. In the figures, the thickness of certain lines, layers, components, elements or features may be exaggerated for clarity.

The terminology used herein is for the purpose of describing particular embodiments only and is not intended to be limiting of the invention. As used herein, the singular forms "a", "an" and "the" are intended to include the plural forms as well, unless the context clearly indicates otherwise. It will be further understood that the terms "comprises" and/or "comprising," when used in this specification, specify the presence of stated features, integers, steps, operations, elements, and/or components, but do not preclude the presence or addition of one or more other features, integers, steps, operations, elements, components, and/or groups thereof. As

used herein, the term “and/or” includes any and all combinations of one or more of the associated listed items.

Unless otherwise defined, all terms (including technical and scientific terms) used herein have the same meaning as commonly understood by one of ordinary skill in the art to which this invention belongs. It will be further understood that terms, such as those defined in commonly used dictionaries, should be interpreted as having a meaning that is consistent with their meaning in the context of the specification and relevant art and should not be interpreted in an idealized or overly formal sense unless expressly so defined herein. Well-known functions or constructions may not be described in detail for brevity and/or clarity.

It will be understood that when an element is referred to as being “on”, “attached” to, “connected” to, “coupled” with, “contacting”, etc., another element, it can be directly on, attached to, connected to, coupled with or contacting the other element or intervening elements may also be present. In contrast, when an element is referred to as being, for example, “directly on”, “directly attached” to, “directly connected” to, “directly coupled” with or “directly contacting” another element, there are no intervening elements present. It will also be appreciated by those of skill in the art that references to a structure or feature that is disposed “adjacent” another feature may have portions that overlap or underlie the adjacent feature.

Spatially relative terms, such as “under”, “below”, “lower”, “over”, “upper” and the like, may be used herein for ease of description to describe one element or feature’s relationship to another element(s) or feature(s) as illustrated in the figures. It will be understood that the spatially relative terms are intended to encompass different orientations of the device in use or operation in addition to the orientation depicted in the figures. For example, if the device in the figures is inverted, elements described as “under” or “beneath” other elements or features would then be oriented “over” the other elements or features. Thus, the exemplary term “under” can encompass both an orientation of “over” and “under”. The device may be otherwise oriented (rotated 90 degrees or at other orientations) and the spatially relative descriptors used herein interpreted accordingly. Similarly, the terms “upwardly”, “downwardly”, “vertical”, “horizontal” and the like are used herein for the purpose of explanation only unless specifically indicated otherwise.

The term “monitoring” refers to the act of measuring, quantifying, qualifying, estimating, sensing, calculating, interpolating, extrapolating, inferring, deducing, or any combination of these actions. More generally, “monitoring” refers to a way of getting information via one or more sensing elements. For example, “blood health monitoring” includes monitoring blood gas levels, blood hydration, and metabolite/electrolyte levels.

The term “physiological” refers to matter or energy of or from the body of a creature (e.g., humans, animals, etc.). In embodiments of the present invention, the term “physiological” is intended to be used broadly, covering both physical and psychological matter and energy of or from the body of an organism. However, in some cases, the term “physiological” is called-out separately to emphasize aspects of physiology that are more closely tied to conscious or subconscious brain activity rather than the activity of other organs, tissues, or cells.

The term “body” refers to the body of a person (or animal) that may utilize an earpiece module according to embodiments of the present invention. Monitoring apparatus, according to embodiments of the present invention may be worn by humans and animals.

Referring to FIG. 1, methods and apparatus for qualifying and quantifying one or more physiological properties of an organism, according to some embodiments of the present invention, are illustrated. An extracted signal indicative of the physiological energy response from two or more distinct regions of an organism is generated following the excitation of at least one region via one or more forms of excitation energy. In the illustrated embodiment, an excitation-sensor module **101** is configured to generate and direct excitation energy towards at least one surface **120** of an organism and to sense the energy response from at least two distinct regions of the surface **120**. The signal from the excitation-source module may be passed to a signal extractor **102** for processing and/or subtracting the signals to generate at least one extracted signal more closely related to a physiological property of interest. This extracted signal may then be sent to a transmitter **104** for wirelessly transmitting the desired information **106** to another device or network and/or to a signal processor **105** for processing the extracted signal, comparing the processed extracted signal with at least one physiological model, and sending a physiological assessment to the transmitter **104**.

The excitation-sensor module **101** may include of one or more excitation source(s) **110**, **112**, having similar or different excitation elements and/or excitation configurations, as well as one more sensor element(s) **111** having similar or different sensor elements and/or sensor configurations. These elements (**110**, **112**, and **111**) are positioned in contact with, or near to, a surface **120** of an organism. The excitation source(s) **110**, **112** can generate energy such as, but not limited to, electromagnetic radiation, mechanical energy, acoustical energy, electrical energy, and/or thermal energy, etc. The sensors **111** can detect one or more of these types of energy.

In some embodiments, an excitation source is a solid-state source, such as a light-emitting diode (LED), laser diode (LD), lamp, radio or microwave transmitter, etc. In some embodiments, a sensor is an acoustic/auscultatory sensor, motion sensor, optical sensor, thermal sensor, etc.

In some embodiments, the excitation sources and sensors are integrated into a wearable device. This wearable device can be configured to process information from the sensors and send processed information telemetrically to another device or network. This other device may be a portable device such as a mobile phone, portable computer, portable entertainment device, embedded computer, or the like. The wearable device may also include at least one communication module for communicating information to the organism and/or entertaining the organism.

FIG. 2 illustrates an excitation-sensor module **101** positioned noninvasively over the surface **120** (i.e., the skin) of an organism such that an optical emitter **212** is positioned over an area largely covering or completely covering a blood vessel and an optical emitter **210** is positioned over an area near, but not covering, the blood vessel. Optical detectors **211** are arranged to detect scattered excitation light from two separate regions and generate at least two separate electrical signals. Signals related to light scattered from the region lacking a blood vessel can be subtracted from signals related to light scattered from the region covering a blood vessel (e.g., via an electronic circuit). These signals can be subtracted in raw analog form through analog mixers, and these signals can also be digitized first and subtracted in digital form. Regardless, the extracted signal contains “cleaner” information about scattered light coming from the blood vessel itself as compared to light scattered by the blood vessel and neighboring skin tissue. Similarly, as the excita-

tion-sensor module **101** is physically one unit, the effects of motion artifacts can also be subtracted because changes in scattered light at each region will typically happen in unison.

The term “blood vessel”, as used herein refers to veins, arteries, capillaries, and the like.

The optical emitters **210**, **212** and optical detectors **211** can be solid state devices. For example, the optical emitters **210**, **212** can include, but are not limited to, a light-emitting diode (LED), a laser diode (LD), a miniature incandescent lamp, a miniature mercury lamp, a light guide delivering light from an outside source (such as the sun or other light source), a multiwavelength source, a microplasma source, an arc source, a combination of these sources, and the like. Special variants of light-emitting diodes, such as resonant-cavity light emitting diodes (RCLEDs), superluminescent LEDs (SLEDs), organic LEDs (OLEDs), and the like can also be utilized. The optical detectors include, but are not limited to, photodiodes (PDs), avalanche photodiodes (APDs), photomultipliers, or other compact optical detectors.

Though only two optical emitters and optical detectors are shown in FIG. 2, it should be understood that multiple optical emitters and optical detectors can be arranged in an array. The greater the number of optical emitters and detectors in an array, the higher resolution of physiological features and properties that can be extracted. For example, the intensity of optical scatter from a blood vessel at multiple points along the surface of skin covering that blood vessel can be used to judge the size of that blood vessel, without having to calibrate a single optical source for each blood vessel. Unfortunately, increasing the number of optical arrays can increase the fabrication costs of an optical module **101**. Additionally, it can become difficult to align and package individual optical sources and detectors on a module for quantifying the size of a blood vessel.

One methodology for reducing the cost and complexity of a high-density optical array is to incorporate a monolithic solid state optical array, such as an LED or LD array. A key benefit of such an array is that solid state optical emitters can alternately operate as optical emitters or optical detectors depending on the electrical biasing. Because these devices can be fabricated monolithically down to the limits of state-of-the-art lithography, a highly dense array of individually controlled LED mesas can be fabricated in a single wafer fabrication run. Thus, an array of optical emitters/detectors can be fabricated self-aligned without needing separate packaging techniques. With such a dense array, the optical emitters can be alternately biased forward and reverse to operate as optical emitters and detectors respectively. For example, for neighboring LED mesas, one LED mesa can be forward-biased to generate light whereas a neighboring LED mesa can be reverse-biased to detect light. When the monolithic array is in proximity to the surface of an organism, the number of mesas detecting significant optical scatter related to a blood vessel can then be used to gauge the size of that blood vessel. Similarly, the intensity of optical scatter at each mesa can be used to gauge the size of that blood vessel.

FIG. 3 illustrates an exemplary monolithic optical emitter array **312** containing individually controlled optical emitters **313** which can also be biased as optical detectors. Though a variety of techniques can be used to control the bias through each mesa, one technique is to bond the metal contacts of each individual mesa to a mounting package **314** having metal bumps aligned to the monolithic array **313** and having circuitry for controlling each individual mesa separately. This packaging forms a module **300** with the array. FIG. 6

shows how an excitation-sensor array module **612**, such as a monolithic optical emitter array module **300**, may be aligned to a blood vessel **620** for gauging the size or shape of the blood vessel, as well as extracting a cleaner signal relating physiological information about the blood vessel **620**.

The fabrication of solid-state monolithic optical arrays is well known to those skilled in the art. Solid-state monolithic optical arrays can be semiconductor optical arrays, such as LED or LD arrays, organic LED arrays, such as OLEDs and the like. OLED arrays can offer a benefit of being flexed, as shown in FIGS. 5A-5B, at least partially around a blood vessel. OLEDs can also be dual-based as optical emitters and detectors, but separate optical detectors can also be printed within an array. The print-style manufacturing technique for fabricating organic electronics makes the manufacture of organic/polymer device arrays potentially less costly and tedious than that of traditional LED arrays. Because of the ability to “print” device components for organic electronics, OLED arrays, organic photodetector arrays, and organic piezoelectric arrays can be deposited in the same module and interlaced in the same array. This adds higher-level physiological sensing functionality by increasing the number of physiological-related parameters that can be monitored at the same time.

Piezoelectric arrays can also be employed for noninvasively monitoring the physiological properties of an organism, according to some embodiments of the present invention. This allows mechanical energy from some piezoelectric elements to couple with a region of the organism while other piezoelectric elements measure the response. The processing of this information to generate information on physiological dimensions or physiological properties can be the same as that described for monolithic LED arrays **312**.

Many polar semiconductors contain piezoelectric properties, and thus several types of device arrays on several types of semiconductors can be used as piezoelectric sensors and/or actuators, according to embodiments of the present invention. For example, metal arsenides and metal nitrides, such as aluminum indium gallium arsenide or aluminum indium gallium nitride alloys, and the like, can be used to fabricate piezoelectric arrays. The elements of these arrays can be micro-manufactured or nano-manufactured as cantilevers, membranes, flexible rods, or the like using standard microelectromechanical systems (MEMS) and nanoelectromechanical (NEMS) fabrication techniques. Similarly, simple device structures such as field effect transistors, resistors, and even light-emitting diodes can be operated as piezoelectric sensors. Thus, an LED array can be used as both an optical emitter-detector array or piezoelectric sensing array depending on the biasing of the array. Methods of fabricating piezoelectric arrays are well known to those skilled in the art. The monolithic piezoelectric actuator-sensor array **400** of FIG. 4 can be fabricated as an array **412** of metallic contacts **413** on a semiconductor surface, where the surface may or may not be defined into individual mesas. The packaging module **414** can be employed in the same manner as package **314** of FIG. 3.

As described earlier, flexible organic/polymer arrays can also be employed for physiological monitoring as shown in FIG. 6. The array elements (e.g., **513**, FIG. 5A) can come from any number of optical emitting (OLED), optical detecting (OLED or organic photodetector), piezoelectric (such as polarized fluoropolymers), or other sensing elements. A secondary screen-printed (or similar) film **523** (FIG. 5B), which may be deposited on the organic polymer array layer **512** or on a separate layer **522**, can be used to electrically

access each device element **513**. In the case of a polymer piezoelectric array **500**, polarized polymers, such as polyvinylidene fluoride (PVDF), can be used as an active piezoelectric element for generating and/or sensing mechanical energy from an organism. For example, by generating mechanical energy with one filament in the array and detecting the mechanical energy response coming from the organism at other filaments, a physiological map of a feature, such as a blood vessel, can be processed. This can be used to gauge the size of a blood vessel opening and closing in time.

Embodiments of the present invention can be used to assess blood pressure or blood pressure properties in a blood vessel. For example, the information on the size of a blood vessel, as well as the change in size of a blood vessel during blood flow, can be combined with information regarding the total flow of blood to assess blood pressure. Namely, the size and change of size in a blood vessel can relate the area of a blood vessel, and this can be combined with the volumetric flow rate of blood to gauge or estimate blood pressure.

Referring to FIG. 6, reflective pulse oximetry can be combined with blood vessel size estimation via optical scatter detection, according to some embodiments of the present invention. For example, an optical emitter generating blue light can be used to generate an optical scatter signal more closely related to the size of a blood vessel, shown by  $\Delta y$  in FIG. 6. An optical emitter generating IR light can be used to generate an optical scatter signal more closely related to the blood flow in the blood vessel, shown by **630** in FIG. 6. A third and fourth optical emitter, violet and red respectively, may be located near (but not covering) the blood vessel, for example in an arrangement as that illustrated in FIG. 2. Optical scatter signals from these sources are more closely related to optical scatter from the skin or other tissue. Thus, when these skin-related optical scatter signals are differentially amplified with respect to their blood-vessel-related counterparts, at least two extracted signals can be generated that are more closely related to the size of a blood vessel and the blood flow rate through a blood vessel. These extracted signals can then be digitized, processed, and compared with a physiological model related to blood pressure to qualify and quantify blood pressure in real time.

The aforementioned IR scatter signal more closely related to the blood flow in the blood vessel may also contain some information related to the optical scatter from the expanding blood vessel wall. Thus, differentially amplifying the aforementioned blue scatter signal more closely related to the size of a blood vessel with respect to the aforementioned IR scatter signal can help subtract artifacts associated with expanding blood vessel size from the desired blood flow information. Thus, second order effects can be alleviated, to at least some degree, from the overall assessment of blood pressure.

Embodiments of the present invention can be utilized for qualifying and quantifying a variety of physiological properties in physiological tissue and fluids. For example, the optical scatter signal associated with blood glucose in a blood vessel can be more accurately and/or precisely extracted. In another embodiment, blood hemoglobin components, such as oxyhemoglobin, methemoglobin, carboxyhemoglobin, and the like, can be more accurately and/or precisely extracted. In these embodiments, the optical scatter response associated with the skin is subtracted from the optical scatter response associated with skin+blood metabolites to generate a clean extracted signal more closely related to blood metabolite quality and quantity. In each case, the

optical signal associated with scatter from the skin tissue is separated from the optical signal associated with the blood vessel or blood components. This embodiment utilizes multiple emitters, multiple detectors, or both, with each emitter and detector located in a distinct region in the vicinity of a blood vessel—either directly over the blood vessel or near but not covering the blood vessel. If the optical emitters and detectors are located too far apart from the region of interest, it can be difficult to extract the desired physiological-related signal. This is because optical scatter from separate areas can be too dissimilar for successful differential amplification and extraction of a clear physiologically related signal.

In some embodiments of the present invention, the same sensors, sensor configurations, and processing, can be used to extract signals related to the physiological properties of the skin. For example, information related to the size of a blood vessel or flow of blood through a blood vessel can be subtracted from an optical scatter signal reflected from the skin. This will yield cleaner information more closely related to the physiological properties of the skin, such as skin metabolite levels, hydration, elasticity, and the like.

As described above, the scatter intensity of light for each wavelength of electromagnetic excitation can be used to qualify and/or quantify a particular physiological parameter. For example, in humans, shorter wavelength optical radiation (blue-UV) reflects largely from the skin, whereas longer wavelength radiation (red-IR) can penetrate through blood vessels (FIG. 7). Thus, an approach for qualifying and/or quantifying at least one physiological property of an organism according to some embodiments of the present invention is to generate at least two extracted signals, each indicative of at least one physiological energy response from at least one region of the organism following the electromagnetic excitation of at least one region with at least two wavelengths of electromagnetic excitation. The wavelength-dependent energy response from each region can then be sensed by at least one neighboring sensor and/or sensor array and converted into at least two electrical signals. This energy response can be mechanical, acoustical/auscultatory, electrical, or thermal in origin. The two or more electrical signals can be converted into extracted signals by filtering out each signal with respect to noise, as described earlier. These extracted signals are each indicative of at least one physiological energy response to at least one wavelength of electromagnetic energy. These extracted signals can then be amplified, compared, processed, and compared with at least one physiological model to qualify and/or quantify at least one physiological property of the organism. One specific example of physiological properties that can be extracted, such as blood metabolites, is shown in FIG. 9.

A specific embodiment of noninvasively qualifying and/or quantifying a particular physiological parameter is shown in FIGS. 8A-8B. In this embodiment, the electromagnetic excitation sources, **810**, **812**, are optical emitters. Optical emitter **810** generates long wavelength radiation and optical emitter **812** generates short wavelength radiation. The optical detector **811** converts the optical scatter from the optical emitters **810**, **812** into an electrical signal. The short wavelength optical emitter **812** generates optical radiation which is reflected from the surface of the blood vessel **820**, whereas the long wavelength optical emitter **810** generates optical radiation which is at least partially reflected from the blood inside the blood vessel. If the optical emitters **810**, **812** are pulsed and synchronized in time with the optical detector **811**, at least two separate signals can be extracted for each excitation wavelength. For example, the electrical signal associated with the short wavelength optical energy from the

optical source **812** is more closely associated with the size of the blood vessel **820**, whereas the electrical signal associated with the long wavelength optical energy from the optical source **810** is more closely associated with the blood flow through the blood vessel. Thus, as described earlier, by comparing these independent signals, an assessment of blood pressure can be estimated.

Embodiments of the present invention described herein can be quite useful when integrated into a wearable device, such as a wearable telemetric device. In some embodiments, a wearable device can communicate telemetrically with a portable computer or portable communication device, such as a cellular phone, personal digital assistant, or the like. Thus, a person wearing the device can view a real-time assessment of personal vital signs through a portable view screen. In some embodiments, this telemetric information can be transmitted through a cellular network and onto the world-wide-web for storage in a database. This stored data can then be accessed through the web. Devices according to embodiments of the present invention can be comprised of compact, low-power solid-state devices, such as LEDs, photodiodes, piezoelectric elements, microphones, NEMS/MEMS devices, or the like. As such, embodiments of the present invention can be integrated into wearable monitors.

FIG. **10** illustrates the use of excitation-sensor modules **1012** in a wearable physiological monitor **1000**. The modules **1012** can be integrated into a flexible circuit board or flexible connector, connected to a Bluetooth processing board. Flexible circuit boards are typically fabricated from a polymer with integrated copper electrodes and circuit paths.

In a particular embodiment, the wearable physiological monitor **1000** can be integrated into the main body **1205** of a telemetric earpiece, as shown in FIG. **11**. FIG. **11** illustrates details about the location of sensors in certain parts of an earpiece module **1205**, according to embodiments of the present invention. The ear support **1201** contains a pinna (helix) cover **1202** that may contain sensors for monitoring physiological and environmental factors. This structure is particularly useful for sensing methodologies which require energy to be transmitted through the thin layers of the pinna (the outer ear). Though any portion of the pinna can be covered and/or contacted, in some embodiments, the pinna cover **1202** overlaps at least a part of the helix or a part of the scapha of an ear (FIG. **12** illustrates a human ear). Likewise, an optical absorption detector, composed of an optical emitter and optical detector, can be integrated into the pinna cover **1202** for monitoring, for example, hydration, dosimetry, skin temperature, inductive galvanometry, conductive galvanometry, and the like.

Galvanometry, the measurement of electrical properties of the skin, can be measured inductively, through contactless electromagnetic induction without contacts, or conductively, with two, three, four, or more conductivity probes. Additionally, a 4-point conductivity probe technique, such as that used for measuring the conductivity of semiconductor wafers, can be applied. A variety of sensors can be integrated into the earpiece fitting **1208**. For example, a galvanometric device can be integrated into the surface **1209** of the earpiece fitting where the earpiece fitting touches the skin of the outer ear. A particularly strong pulse response can be monitored with excitation-sensor modules such as those described above mounted in the earpiece fitting region **1209**, touching the acoustic meatus (FIG. **12**). Additionally, an inductive device, such as an inductive coil **1214**, can be integrated along the earpiece fitting body to measure movements of the tympanic membrane inductively. The inductive impedance

can also be measured with the inductive coil **1214** or another inductive sensor, and this can be applied towards contactless galvanometry. The inductive coil **1214** can include one or more coils arranged in any orientation, and a core material, such as an iron-containing material, may be used to improve the sensitivity of the response. In some cases, multiple coils may be used to facilitate the canceling of stray electromagnetic interference. Sensors can also be integrated into the end tip **1212** of the earpiece fitting **1208** to measure physiological properties deeper into the ear canal. For example, the modules of FIGS. **2-4** and **5A-5B** may be located in, at, or near the end tip region **1212** in a module **1213**. The sensors on the module **1213** in this region are carefully arranged so as not to prevent the transmission of sound (from the built-in communication module) and to not be distorted during earpiece placement and removal. The end tip sensor module **1213** can contain several types of sensors for generating multiple types of energy and detecting multiple types of energy, and this module can be integrated into the speaker module (part of the communication module) inside the earpiece fitting **1208** that is used for sound transmission to the user during telemetric conversations. In some embodiments, the speaker module can be used as a microphone to measure auscultatory signals from the body. This may be especially useful for measuring low frequency signals less than 1000 Hz. Employing the speaker as a microphone may require impedance matching to maximize the auscultatory signal extraction. The modules of FIGS. **2-4** and **5A-5B** can be located in, at, or near other parts of the earpiece module, such as the earpiece fitting **1208** surface **1209**, the ear support **1201**, or the earpiece body **1205**.

Another multifunctional earpiece module **1500**, according to embodiments of the present invention, is illustrated in FIG. **13**. The illustrated earpiece module **1500** includes the embodiments illustrated in FIG. **11**, such as a pinna cover **1502**, an ear support **1501**, a mouthpiece **1516**, an earpiece body **1505**, and the like. Additionally, the earpiece module **1500** may contain an extension **1511** with sensors for monitoring jaw motion, arterial blood flow near the neck, or other physiological and environmental factors near the jaw and neck region.

The person illustrated in FIG. **13** is also wearing an earring monitor **1514** according to embodiments of the present invention. Because at least one portion of an earring may penetrate the skin, earring monitor **1514** may contain sensors and telemetric circuitries that provide access to various blood analytes through iontophoresis and electrochemical sensing that may not be easily accessible by the other portions of the earpiece module **1500**. Additionally, the earring monitor **1514** may provide a good electrical contact for ECG or skin conductivity.

The foregoing is illustrative of the present invention and is not to be construed as limiting thereof. Although a few exemplary embodiments of this invention have been described, those skilled in the art will readily appreciate that many modifications are possible in the exemplary embodiments without materially departing from the teachings and advantages of this invention. Accordingly, all such modifications are intended to be included within the scope of this invention as defined in the claims. The invention is defined by the following claims, with equivalents of the claims to be included therein.

That which is claimed is:

1. A method of assessing blood pressure in an organism, the method comprising:
  - directing light at one or more regions of the organism via at least two optical emitters, wherein at least one optical

13

emitter generates light at a first wavelength, wherein at least one other optical emitter generates light at a second wavelength shorter than the first wavelength, and wherein the second wavelength is in the range of blue-UV;

detecting, via an optical detector, light at the first and second wavelengths scattered from the organism and generating, via the optical detector, a first electrical signal associated with the first wavelength and a second electrical signal associated with the second wavelength; and

processing, via at least one processor, the first and second electrical signals, wherein the processing comprises:

filtering each of the first and second electrical signals with respect to skin motion noise to generate a first extracted signal associated with the first wavelength and a second extracted signal associated with the second wavelength that is distinct from the first extracted signal, wherein the first extracted signal comprises information about blood flow through a blood vessel of the organism, and wherein the second extracted signal comprises information about size of the blood vessel; and

comparing the first extracted signal and the second extracted signal, responsive to generation of each by the filtering with respect to the skin motion noise, in context of a physiological model to assess the blood pressure of the organism, wherein the comparing comprises:

calculating the blood pressure of the organism based on an area of the blood vessel and based on a volumetric flow rate of blood therein, wherein the area is based on the size of the blood vessel and a change in the size thereof indicated by the second extracted signal, and wherein the volumetric flow rate is indicated by the first extracted signal.

14

2. The method of claim 1, wherein the at least two optical emitters and the optical detector are integrated into a wearable device worn by the organism.

3. The method of claim 2, wherein the wearable device comprises an earpiece module.

4. The method of claim 2, wherein the wearable device comprises a telemetric device.

5. The method of claim 1, wherein the at least two optical emitters are selected from the group consisting of laser diodes (LDs), light-emitting diodes (LEDs), and organic light-emitting diodes (OLEDs).

6. The method of claim 1, wherein the at least two optical emitters, the optical detector, and the at least one processor are integrated into a wearable device worn by the organism.

7. The method of claim 1, wherein filtering each of the first and second electrical signals with respect to skin motion noise comprises:

subtracting a skin-related optical scatter signal from the first electrical signal to generate the first extracted signal containing the information about the blood flow; and

subtracting the skin-related optical scatter signal from the second electrical signal to generate the second extracted signal containing the information about the size of the blood vessel.

8. The method of claim 7, wherein the skin-related optical scatter signal is detected at a region of the organism that is proximate to the optical detector.

9. The method of claim 1, wherein filtering each of the first and second electrical signals with respect to skin motion noise comprises:

differentially amplifying a skin-related optical scatter signal relative to the first and second electrical signals.

10. The method of claim 1, wherein the light generated by the at least two optical emitters is pulsed and synchronized in time.

\* \* \* \* \*

专利名称(译)	使用激发传感器模块和相关设备和方法的无创生理分析		
公开(公告)号	<a href="#">US9808204</a>	公开(公告)日	2017-11-07
申请号	US13/566269	申请日	2012-08-03
[标]申请(专利权)人(译)	勒伯夫史蒂芬FRANCIS TUCKER JESSE BERKLEY AUMER MICHAEL EDWARD		
申请(专利权)人(译)	勒伯夫史蒂芬FRANCIS TUCKER JESSE BERKLEY AUMER MICHAEL EDWARD		
当前申请(专利权)人(译)	VALENCELL INC.		
[标]发明人	LEBOEUF STEVEN FRANCIS TUCKER JESSE BERKLEY AUMER MICHAEL EDWARD		
发明人	LEBOEUF, STEVEN FRANCIS TUCKER, JESSE BERKLEY AUMER, MICHAEL EDWARD		
IPC分类号	A61B5/021 A61B5/00 A61B5/1455 A61B5/026 A61B5/0295 A61B5/02 A61B5/024 A61B6/00		
CPC分类号	A61B5/721 A61B5/0261 A61B5/0295 A61B5/02116 A61B5/02141 A61B5/14552 A61B5/6815 A61B5/6838 A61B5/1455 A61B2562/046 A61B5/021 A61B2562/0233		
审查员(译)	克里默MATTHEW		
优先权	61/000181 2007-10-25 US		
其他公开文献	US20120296184A1		
外部链接	<a href="#">Espacenet</a> <a href="#">USPTO</a>		

摘要(译)

提供了用于限定和量化在来自不需要的源的干扰中从可穿戴传感器提取的依赖于激励的生理信息的方法和装置。用至少一种激发能量询问生物体，感测来自两个或更多个不同生理区域的能量响应信号，并处理这些信号以产生提取信号。将提取的信号与生理模型进行比较以限定和/或量化生理特性。另外，通过比较通过可穿戴传感器测量的激发波长相关响应与生理模型，可以限定和量化重要的生理信息。

