



US009782096B2

(12) **United States Patent**  
**Jaakkola et al.**

(10) **Patent No.:** **US 9,782,096 B2**  
(45) **Date of Patent:** **Oct. 10, 2017**

(54) **TEXTILE SUBSTRATE FOR MEASURING PHYSICAL QUANTITY**

(75) Inventors: **Heikki Jaakkola**, Kankaanpää (FI);  
**Tommi Tuulenmäki**, Tampere (FI);  
**Akseli Reho**, Kankaanpää (FI)

(73) Assignee: **Clothing Plus MBU Oy**, Kankaanpää (FI)

(\*) Notice: Subject to any disclaimer, the term of this patent is extended or adjusted under 35 U.S.C. 154(b) by 0 days.

(21) Appl. No.: **13/982,448**

(22) PCT Filed: **Jan. 31, 2012**

(86) PCT No.: **PCT/FI2012/050083**

§ 371 (c)(1),  
(2), (4) Date: **Oct. 8, 2013**

(87) PCT Pub. No.: **WO2012/104484**

PCT Pub. Date: **Aug. 9, 2012**

(65) **Prior Publication Data**

US 2014/0024915 A1 Jan. 23, 2014

(30) **Foreign Application Priority Data**

Jan. 31, 2011 (FI) ..... 20115094

(51) **Int. Cl.**

**A61B 5/0408** (2006.01)

**A61B 5/00** (2006.01)

(Continued)

(52) **U.S. Cl.**

CPC ..... **A61B 5/04085** (2013.01); **A61B 5/0002** (2013.01); **A61B 5/0245** (2013.01);

(Continued)

(58) **Field of Classification Search**

CPC ..... **A61B 5/04085**; **A61B 5/6804**; **A61B 6805/6806**; **A61B 6805/6807**; **A61B 6805/681**

(Continued)

(56) **References Cited**

U.S. PATENT DOCUMENTS

3,479,565 A 11/1969 Ross et al.

3,631,298 A 12/1971 Davis

(Continued)

FOREIGN PATENT DOCUMENTS

CH 662717 A5 10/1987

CN 200966186 Y 10/2007

(Continued)

OTHER PUBLICATIONS

Swedberg, Claire, "Fulfillment Efficiency With RFID", RFID Journal, Nov. 10, 2011, pp. 1-4, <http://www.rfidjournal.com/article/view/8953>.

*Primary Examiner* — Lee S Cohen

(74) *Attorney, Agent, or Firm* — Volpe and Koenig, P.C.

(57) **ABSTRACT**

A textile substrate with a measuring sensor for measuring a physiological signal. The textile substrate has integrated irremovably therewith a base structure component for electronics, such as for example a plastic base for a transmitter for attaching the transmitter and other electronics to the substrate irremovably by way of said base structure component. In addition, signal transfer elements from the measuring sensor are adapted to extend in a watertight manner to the electronics through said base structure component integrated irremovably with the textile substrate.

**15 Claims, 2 Drawing Sheets**

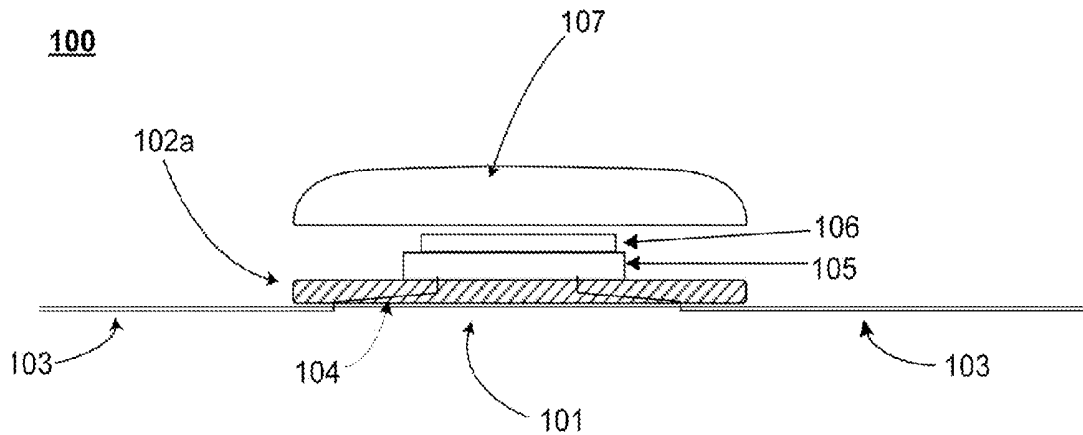

(51)	<b>Int. Cl.</b> <i>A61B 5/0245</i> (2006.01) <i>A61B 5/024</i> (2006.01) <i>A61B 5/04</i> (2006.01) <i>H01R 13/52</i> (2006.01)	2011/0160601 A1* 6/2011 Wang ..... A61B 5/04085 600/509 2011/0213208 A1 9/2011 McKenna et al. 2011/0282164 A1 11/2011 Yang et al. 2013/0085538 A1 4/2013 Volpe et al. 2013/0160183 A1 6/2013 Reho et al. 2013/0274587 A1 10/2013 Coza et al. 2013/0281795 A1 10/2013 Varadan 2013/0321168 A1 12/2013 Mahony et al. 2014/0015410 A1 1/2014 Shibata et al. 2014/0090146 A1 4/2014 Yeomans et al. 2014/0275883 A1 9/2014 Haisley et al. 2014/0343392 A1 11/2014 Yang 2015/0025354 A1 1/2015 Salonius et al.
(52)	<b>U.S. Cl.</b> CPC ..... <i>A61B 5/02438</i> (2013.01); <i>A61B 5/04</i> (2013.01); <i>A61B 5/0408</i> (2013.01); <i>A61B</i> <i>5/6804</i> (2013.01); <i>A61B 5/6807</i> (2013.01); <i>H01R 13/5213</i> (2013.01); <i>Y10T 29/49002</i> (2015.01)	
(58)	<b>Field of Classification Search</b> USPC ..... 600/388-390 See application file for complete search history.	

FOREIGN PATENT DOCUMENTS

(56)	<b>References Cited</b>  U.S. PATENT DOCUMENTS  3,954,100 A 5/1976 Sem-Jacobsen 4,729,377 A 3/1988 Granek et al. 4,763,660 A 8/1988 Kroll et al. 5,450,845 A 9/1995 Axelgaard 5,624,736 A 4/1997 DeAngelis et al. 6,047,203 A 4/2000 Sackner et al. 6,080,690 A* 6/2000 Leby et al. .... 442/209 6,145,551 A 11/2000 Jayaraman et al. 6,210,771 B1 4/2001 Post et al. 6,368,990 B1 4/2002 Jennergren et al. 6,381,482 B1 4/2002 Jayaraman et al. 6,400,975 B1 6/2002 McFee 6,501,055 B2 12/2002 Rock et al. 6,729,025 B2 5/2004 Farrell et al. 6,941,775 B2 9/2005 Sharma 7,206,630 B1 4/2007 Tarler 7,559,902 B2 7/2009 Ting et al. 7,712,373 B2 5/2010 Nagle et al. 8,003,887 B1 8/2011 Hsieh et al. 8,224,418 B2 7/2012 Birnbaum et al. 8,750,959 B2* 6/2014 Lindberg et al. .... 600/386 2002/0026112 A1 2/2002 Nissila et al. 2002/0076948 A1 6/2002 Farrell et al. 2002/0082491 A1 6/2002 Nissila 2002/0124295 A1 9/2002 Fenwick et al. 2003/0224685 A1 12/2003 Sharma 2004/0224138 A1 11/2004 Farrell et al. 2005/0054941 A1 3/2005 Ting et al. 2005/0275416 A1 12/2005 Hervieux et al. 2006/0124193 A1 6/2006 Orr et al. 2006/0152377 A1 7/2006 Beebe et al. 2006/0224072 A1 10/2006 Shennib 2006/0267790 A1 11/2006 Matthiessen et al. 2007/0073131 A1 3/2007 Ryu et al. 2007/0083096 A1 4/2007 Paradiso 2007/0177298 A1 8/2007 Jaatinen et al. 2007/0285868 A1 12/2007 Lindberg et al. 2007/0298666 A1 12/2007 Kurth 2008/0208029 A1* 8/2008 Thijs et al. .... 600/388 2008/0287770 A1 11/2008 Kurzweil et al. 2009/0018428 A1 1/2009 Dias et al. 2009/0112079 A1* 4/2009 Hassonjee et al. .... 600/388 2009/0173529 A1 7/2009 Lee et al. 2009/0281394 A1 11/2009 Russell et al. 2010/0198043 A1* 8/2010 Holzer et al. .... 600/388 2010/0298899 A1 11/2010 Donnelly et al.
------	--

CN	201114998 Y	9/2008
DE	10338029 A1	4/2005
DE	102004058731 A1	6/2006
EP	0509689 A2	10/1992
EP	0855167 A1	7/1998
EP	0947967 A1	10/1999
EP	1095612 A1	5/2001
EP	1504739 A1	2/2005
EP	1632926 A1	3/2006
EP	1676528 A1	7/2006
EP	1894523 A1	3/2008
EP	2057943 A1	5/2009
EP	2082967 A1	7/2009
EP	2975915 A1	1/2016
FI	119456 B	11/2008
FI	119716 B	2/2009
GB	2257523	* 1/1993
GB	2503716 A	1/2014
JP	2015-083045 A2	4/2015
KR	2012-0009000 A	2/2012
WO	99/64657 A2	12/1999
WO	00/19957 A1	4/2000
WO	00/44411 A1	8/2000
WO	01/01855 A1	1/2001
WO	01/02052 A2	1/2001
WO	01/34866 A1	5/2001
WO	01/48291 A1	7/2001
WO	01/49912 A1	7/2001
WO	01/78577 A2	10/2001
WO	02/30279 A1	4/2002
WO	02/32665 A1	4/2002
WO	02/40091 A2	5/2002
WO	WO 02/071935 A1	9/2002
WO	02/098659 A1	12/2002
WO	03/010561 A2	2/2003
WO	WO 2004/086968 A1	10/2004
WO	2006/029105 A2	3/2006
WO	2006/068811 A1	6/2006
WO	2006/094152 A2	9/2006
WO	2006/128957 A1	12/2006
WO	2006/129272 A2	12/2006
WO	WO 2007/050650 A2	5/2007
WO	2007/107906 A1	9/2007
WO	2008/071843 A1	6/2008
WO	WO 2009/107906 A1	9/2009
WO	2012/176193 A1	12/2012
WO	2013/033238 A1	3/2013
WO	2015/136521 A1	9/2015

\* cited by examiner

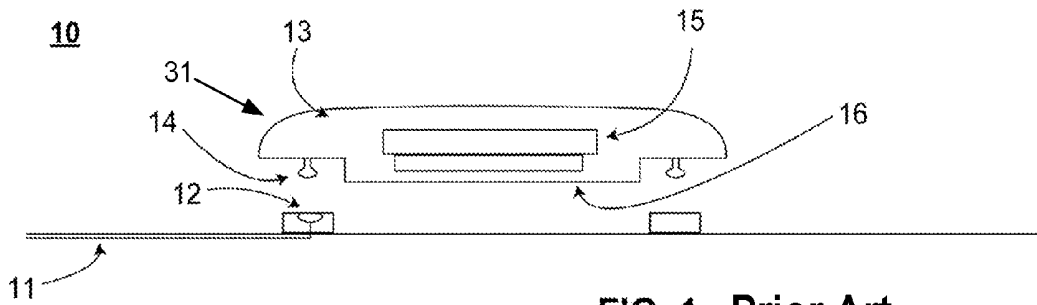

FIG. 1 Prior Art

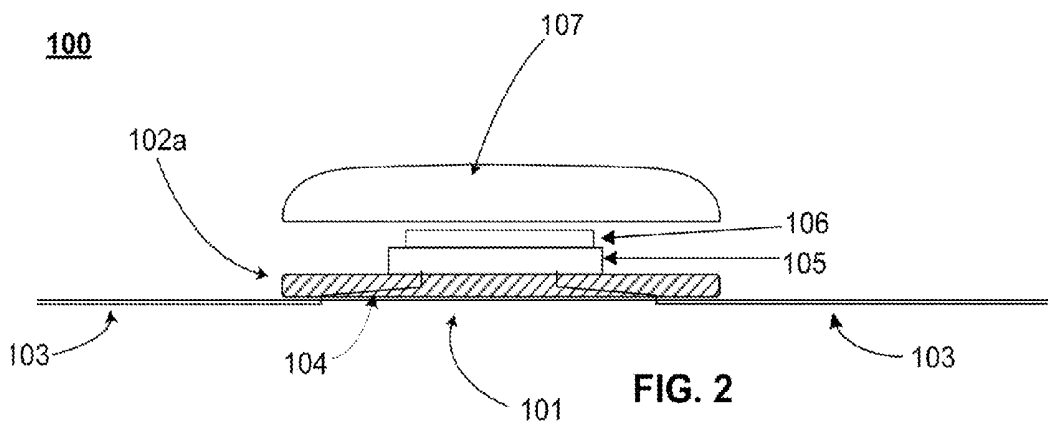

FIG. 2

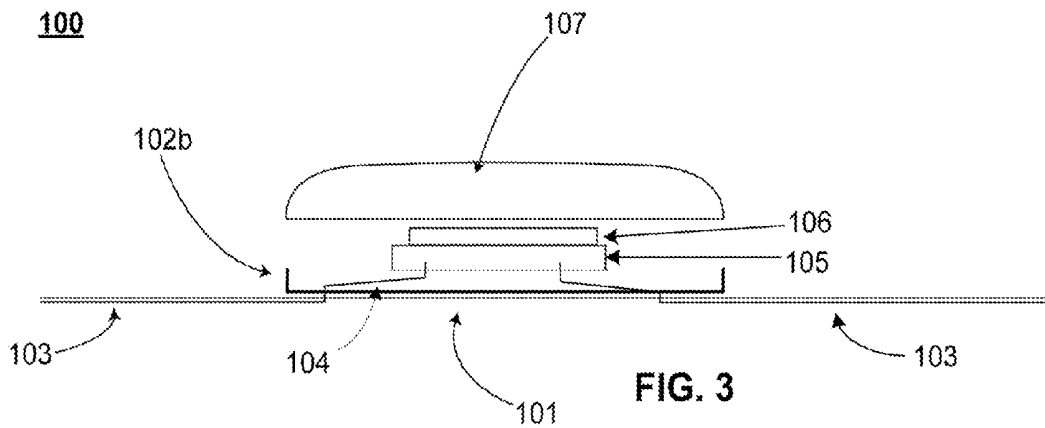

FIG. 3

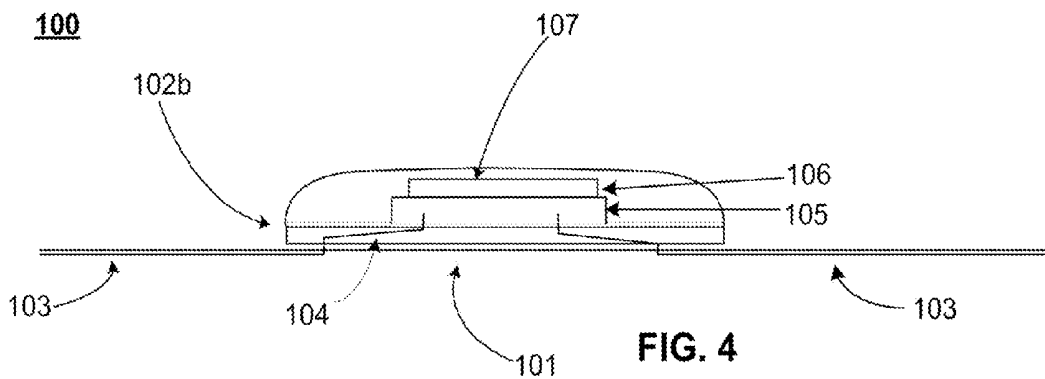

FIG. 4

FIG. 5

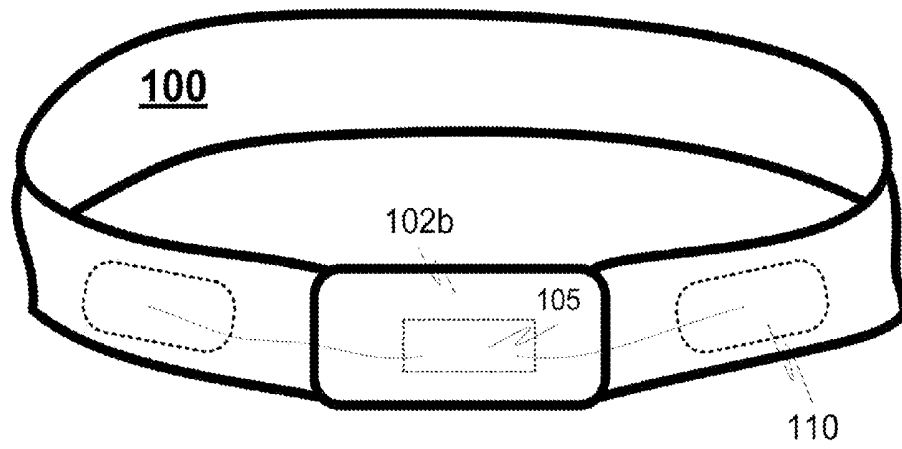

FIG. 6

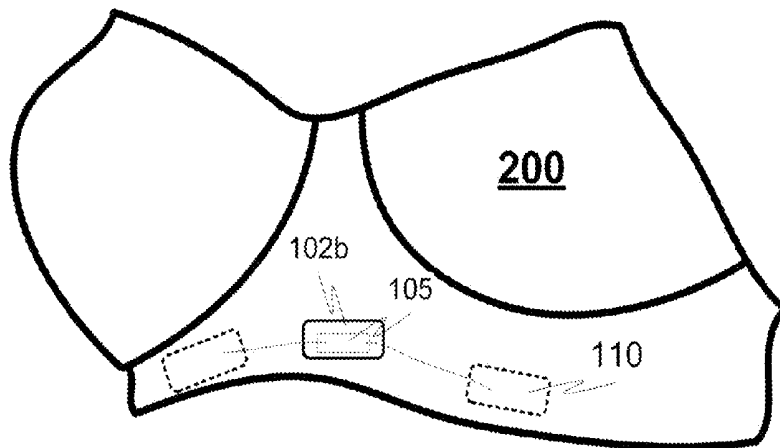
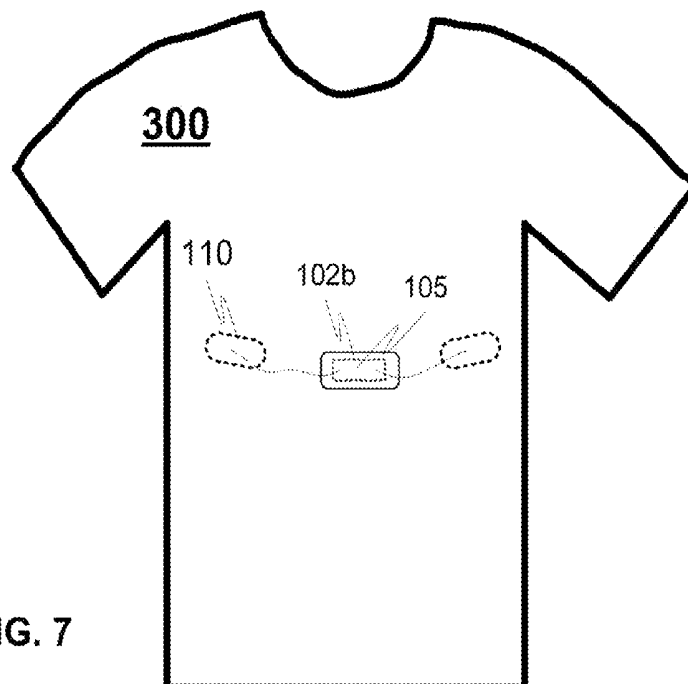

FIG. 7



## TEXTILE SUBSTRATE FOR MEASURING PHYSICAL QUANTITY

### PRIORITY CLAIM

This application is a National Phase entry of PCT Application No. PCT/FI2012/050083, filed Jan. 31, 2012, which claims priority from Finland Application No. 20115094, filed Jan. 31, 2011, the disclosures of which are hereby incorporated by referenced herein in their entirety.

### TECHNICAL FIELD OF THE INVENTION

The present invention relates to a textile substrate for measuring a physical quantity. The present invention is particularly related to a textile sensor substrate, wherein the textile substrate comprises a measuring sensor, such as for example electrodes, for measuring a physiological signal.

### BACKGROUND OF THE INVENTION

The prior art discloses various solutions with a sensor for measuring a physical quantity, such as for example a heart rate band or belt. The heart rate band is made of skin contacting electrodes, and electronics which identifies a signal emanating from the electrodes and transmits the received heart rate data to a terminal, for example to a watch or a mobile communicator. For conducting a measurement, the heart rate band is put on for example around the thorax, whereby the electrodes make contact with the skin around the chest close to the heart for a measuring process.

For example, publication FI 119456 discloses one heart rate belt with a sensor, wherein the heart rate belt has its sensor in a first part of a connector mechanism and has its processing or transmitter unit in a second part of the connector mechanism. Both parts include magnetic layers, by means of which the parts connect releasably to each other by way of mechanical coupling. In the solution, the electrical conductor layers extending from the sensor are connected electrically with the second part electrical components of the processing or transmitter unit as a result of the aforesaid mechanical coupling.

In addition, publication FI 119716 discloses a heart rate measuring arrangement comprising a band-like structural component, wherein the structural component, in terms of its material, is flexible, soft, and closely fitting to the skin surface, such as for example a band-aid type adhesive tape. The arrangement includes an electronic unit in electrical communication with heart rate measuring electrodes. The unit is arranged in a casing which comprises a gripping means for attaching the unit to the band-like component of the electrode structure, such that the gripping means provide an electrical connection between the electrodes and the electronic unit. The gripping means is for example an attachment slot, a pivoted clamping clip or the like.

The prior art measuring arrangements are typically all plastic or rubber in structure, wherein for example the measuring band is fabricated with injection molding technology by pressing the conducting plastic electrodes, plastic insulations and electronics within the structure.

The prior art solutions nevertheless involve certain problems. Plastic bands are cold, among other things, and the hard and cold presence thereof does not feel comfortable on the skin. Therefore, recent newcomers to the marketplace include also heart rate measuring bands made partially of textile. On the other hand, a problem with partially textile bands is that the manufacturing processes of textile and

those of plastics as well as those of electronics are clearly different from each other in terms of character and technology, which is why the textile sensor band, and electrodes integrated therewith, must be manufactured in a separate process and, respectively, the transmitter module must be manufactured in a separate process. A particular problem here is due to the fact that, in order to achieve a final product or, in other words, in order to bond a textile band and electronics to each other, it is absolutely necessary to provide therebetween a mechanically and electrically reliable connection, by which connection an electrical measurement signal can be delivered from the skin and sensors to the electronics. Since the measurement signal is highly sensitive to interferences and the environment is particularly demanding (sweaty and with motion disturbances), the connection is subject to quite high qualifications. In addition to communicating the signal, the connection is required, among other things, to retain the transmitter module mechanically immobile in attachment with a textile band. Coming up with sufficiently reliable bonding technique between a textile band and electronics is nevertheless quite expensive considering the final product.

It is a rough estimate that the price of a plastic heart rate band, having electronics integrated as a part of the plastic band, is only about 60% of that of a separate textile band and a transmitter attached thereto with prior art technology. The most significant cost factor is the necessary bonding technology between a textile band and a plastic transmitter. In most commercial solutions, the bonding technique between a band and a transmitter is typically implemented with snap fasteners.

### SUMMARY OF THE INVENTION

One objective of the present invention is to eliminate or at least to alleviate drawbacks related to the prior art. According to one embodiment, the present invention pursues to provide such a textile substrate for measuring a physiological signal, wherein the expensive bonding technique of the prior art could be relinquished and wherein the motion disturbance-hampered and moist environment would not be able to cause interference in the sensitive measurement signal. In addition, the present invention pursues to make it possible, among other things, that the manufacturing processes of textiles as well as those of electronics could still be maintained separate from each other whenever necessary for thereby taking advantage of the characteristic features and knowledge of both industries. It is a particular objective of the present invention to enable the integration of textile and electronics quickly, conveniently, cost efficiently and with functional reliability for providing a reliable product.

Some objectives of the present invention are accomplished for example with a textile substrate.

In some aspects, the textile substrate of the present invention comprises a measuring sensor for measuring a physiological signal, wherein the textile substrate is provided with a region having irremovably integrated therewith a structure more rigid than the textile substrate structure for the attachment of electronics to said region irremovably by way of said more rigid structure, and signal transfer elements being adapted to be connected across said region to the electronics in a watertight manner.

In some aspects, a method for manufacturing a textile substrate of the present invention comprises providing the textile substrate with measuring sensors for measuring a physiological signal, wherein the method further comprises providing the textile substrate with a region, with said region

being irremovably integrated a structure more rigid than the textile substrate structure for the attachment of electronics irremovably to said region by way of said more rigid structure, and signal transfer elements being adapted to be connected from the measuring sensors across said region to the electronics in a watertight manner.

In some aspects, a wearable article of the present invention comprises a heart rate belt or band, or a garment, for example a shirt, a bra, a sports accessory, an undergarment, a sock, or a pair of pants, wherein the wearable article comprises a textile substrate, wherein said textile substrate comprises a measuring sensor for measuring a physiological signal, wherein the textile substrate is provided with a region, said region having irremovably integrated therewith a structure more rigid than the textile substrate structure for the attachment of electronics to said region irremovably by way of said more rigid structure, and signal transfer elements being adapted to be connected across said region to the electronics in a watertight manner.

According to one embodiment of the present invention, the textile substrate comprises a measuring sensor for measuring a physiological signal. The sensor is most preferably implemented with appropriate electrodes for measuring a physiological signal, such as for measuring for example heart rate, respiratory rate, oxygen saturation, temperature, ECG, EEG, or electrical impedance. In the present invention, the textile substrate is preferably provided with a region for the attachment of electronics, such as a transmitter, to the substrate across said region in an irremovable manner. In addition, signal transfer elements from the measuring sensor are adapted to be connected to the electronics by way of said region in a watertight manner.

According to one preferred embodiment, said region has irremovably integrated therewith a structure, most preferably as early as concurrently with manufacturing the substrate, which structure is more rigid than the textile substrate structure, and to which the electronics, for example a wireless transmitter and measurement data processing electronics, can be attached in an irremovable manner. According to a particularly preferred embodiment, said more rigid structure is a base structure, for example a plastic base for electronics, for example a transmitter. In this case, the actual textile component can be manufactured separately and, concurrently with its manufacturing process, with said textile component can be integrated for example a plastic base for the transmitter, and the plastic base can be provided with signal transfer conductors extending from the electrodes. Respectively, in connection with assembling the final product, the electronics will be attached to the base structure irremovably as described elsewhere in this document.

This offers obvious benefits over the prior art solutions, because thereby e.g. the manufacturing processes of textiles as well as those of electronics can still be maintained separate from each other, and hence advantage can be taken of the characteristic features and knowledge of both industries. The present invention enables for example the integration of a transmitter as a textile band component during textile manufacturing across a plastic base integrated therewith at any manufacturing stage of the band after the plastic base has been integrated with the textile.

Most preferably, said base structure for a transmitter is, in terms of its mechanical design, such that it functions as a mechanical mating component for the transmitter (or other possible electronics), thus enabling the transmitter to be attached as a mating component of the base structure irremovably to said textile substrate by way of the base structure. The attachment can be implemented or secured not

only by mating component technique but also, among other means, by injection molding, gluing, sewing, screws, upsetting, ultrasonic welding, and/or by high frequency or heat lamination. In addition, the base structure is attached to the textile substrate most preferably for example by injection molding, gluing, sewing, screws, upsetting, ultrasonic welding, and/or by high frequency or heat lamination. The measurement signal is conducted from electrodes to electronics most preferably by signal transfer elements implemented with conductors. According to one embodiment of the present invention, the conductors connect from the textile substrate across said region, or a rigid structure irremovably integrated therewith, such as for example across the plastic base of a transmitter, to the electronics by way of watertight penetrations or other watertight arrangements in an electrical fashion. According to one preferred embodiment, the conductors extend to the electronics directly through the plastic base in a water tight manner without any separate elements. It is also possible that the plastic base of a transmitter be provided with signal transfer elements, for example pins, by way of which the signal is adapted to proceed from conductors to electronics in an electrical manner. When electronics is attached to a plastic base irremovably as described in this document, the plastic base and the electronics in attachment therewith establish one integral assembly and for example perspiration is not able to cause problems or disruptions for electrical connections between signal transfer conductors and electronics.

According to one embodiment of the present invention, on top of the transmitter or other electronics is provided a second component structurally more rigid than the textile substrate structure, such as for example a protective cover for protecting the transmitter and other electronics at least mechanically, whereby the protective cover, jointly with the base component, makes up an enclosure for the transmitter and other electronics, as well as for a battery. It should be noted that between said substrate and the second component placed on top of the electronics exists just a mechanical connection, but no electrical connections. According to one embodiment, said second component, for example a protective cover, is designed to be removable for enabling a battery replacement, for example. Furthermore, said second component can be at least partially coated with textile.

The present invention offers obvious benefits over the prior art. For example, in the fixed integration of a transmitter's base and a textile component, for example a textile band for the heart rate belt, there is achieved not only the avoidance of expensive technology but at the same time also a watertight and durable penetration of electrodes or signal transfer conductors into the transmitter enclosure. The transmitter's base structure integrated with the textile component provides a natural location for transmitter electronics. This plastic interface provides a surface to which all current plastics and electronics manufacturers will be able to attach their particular electronics. The enclosure is closed most preferably with a transmitter's cover, which, according to one embodiment, can be openable for example for a battery replacement. What is essential, however, is that there are no electrical signals traveling between the openable cover (the second component set on top of said substrate and the electronics) and the base. Accordingly, the cover only functions as a seldom operated battery replacement opening. In case the battery replacement is not desirable, the cover can be for example welded permanently to the attachment with

the transmitter's base, whereby the electronics is encapsulated for a permanent component of the band.

#### BRIEF DESCRIPTION OF THE DRAWINGS

Preferred embodiments of the invention will be described in the next section a little more precisely with reference to the accompanying figures, in which

FIG. 1 shows one typical heart rate band of the prior art, FIG. 2 shows one exemplary heart rate band according to one preferred embodiment of the present invention,

FIG. 3 shows another exemplary heart rate band according to one preferred embodiment of the present invention,

FIG. 4 shows one exemplary heart rate band in a closed condition according to one preferred embodiment of the present invention,

FIG. 5 shows an example of a wearable article according to the present invention,

FIG. 6 shows an example of a wearable article according to the present invention, and

FIG. 7 shows an example of a wearable article according to the present invention.

#### DETAILED DESCRIPTION OF FIGURES

FIG. 1 shows one typical heart rate band **10** of the prior art, wherein from a skin contacting sensor extends a conductor **11** to a connection **12** present in the band, whereby a transmitter module **13** is connected in an electrically and mechanically releasable manner by way of a connection **14** present in the transmitter module. The connection is most typically implemented as a snap fastener type coupling. The transmitter module **13**, which is releasably attachable to the band by means of a snap fastener type coupling, comprises generally also electronics **15** and a battery **16**. The battery **16** is typically located at the bottom of the transmitter module **13** for a convenient replacement by releasing the module from the sensor band's connector mechanisms **12**. In the prior art solution, for example perspiration has an easy access into a connection implemented with snap fasteners, thus being likely to cause interference in the measurement signal along with vibration.

FIG. 2 shows one exemplary heart rate band **100** according to one preferred embodiment of the present invention, wherein a body component of the heart rate band is established by a textile sensor substrate **101**, which is provided with a region **102a** for the attachment of electronics to the substrate across said region **102a** in an irremovable manner. It is also across said region **102a** that signal transfer elements **103** extending from a measuring sensor are adapted to connect to the electronics in a watertight manner. The region **102a** can be designed for example in such a manner that, when placed thereon, the electronics can be attached to the region and thereby to the textile substrate irremovably for example with a technique described elsewhere in this document.

In the heart rate band depicted in FIG. 2, the conductors **103** are adapted to extend most preferably from the textile substrate **101** through said region **102a** directly **104** to the electronics **105**. Said irremovably attached electronics **105** comprises most preferably at least a transmitter for the wireless transmission of measured signals. The electronics may further comprise also elements for processing measurement signals.

In the heart rate band **100**, on top of said region **102a** and the electronics **105** as well as the battery **106** is most preferably provided a cover **107**, whereby the cover **107**,

jointly with said region **102a**, makes up an enclosure type member for protecting the electronics and the battery mechanically. The enclosure can be openable for an easy replacement of the battery which lies on top.

FIG. 3 depicts another exemplary heart rate band **100** according to one preferred embodiment of the present invention, which is structurally highly similar to that shown in FIG. 2, and reference numbering for the like elements is consistent with that of FIG. 2. With regard to a textile substrate **101** in FIG. 3, the textile substrate has irremovably integrated therewith a base structure **102b** for electronics, such as for example a plastic transmitter base, with a transmitter **105** attached irremovably thereto. On top of the transmitter (and other possible electronics) **105** is most preferably provided a battery **106**. Similarly, the heart rate band depicted in FIG. 3 has conductors **103** adapted to extend most preferably from the textile substrate **101** through said transmitter's base structure **102b** directly **104** to the electronics **105**, thus providing at the same time a watertight and mechanically durable penetration through the base structure **102b**. In addition, adapted to be placed on top of the electronics and the battery is a cover **107**, which can be designed to be openable for enabling a battery replacement. According to one embodiment, the cover can be adapted to become attached to the transmitter's base structure **102b** as presented in FIG. 4. According to one embodiment, the cover can be coated with textile.

FIGS. 5, 6 and 7 illustrate a few examples of wearable articles **100**, **200**, **300** of the present invention, wherein, depending on the wearable article, sensors **110** made up by electrodes are placed in an appropriate location for measuring a desired physical quantity, such as, for example, close to the heart in a bra **200** and a shirt **300** for measuring the heart rate.

The foregoing are just a few embodiments of the present invention. The principle according to the present invention can naturally be varied within the scope of protection defined by the claims, regarding for example implementation details and fields of use. It should particularly be noted that, although the above description deals with a heart rate band or belt as one example of a textile substrate, the present invention is by no means limited solely to those, but said textile substrate can also be some other wearable article or garment, such as for example a shirt, a bra, a sports accessory, an undergarment, a sock, or a pair of pants. In addition, although it has been stated in several examples that the textile substrate has irremovably integrated therewith a plastic base for electronics, such as for a transmitter, the material of said base structure may just as well be a material other than plastics.

The invention claimed is:

1. A device comprising a textile substrate, wherein the textile substrate comprises:

measuring sensors for measuring a physiological signal; signal transfer conductors which are coupled with and extended from the measuring sensors along the textile substrate; and

a base structure component of physiological signal processing or transmitting electronics,

wherein the base structure component is more rigid than the textile substrate and is irremovably and permanently integrated into the textile substrate,

wherein said base structure component comprises signal transfer elements for connecting said electronics to the signal transfer conductors, and,

wherein the signal transferring from the measuring sensors to the electronics is implemented by electrically

7

coupling the signal transfer conductors from the textile substrate to the signal transfer elements of the base structure component and thereby enabling signal transferring through said base structure component to said electronics in an irremovably, permanently integrated and watertight manner.

2. A device as set forth in claim 1, wherein the measuring sensors are implemented with electrodes and said electrodes being coupled with said conductors, and wherein said irremovably attached electronics comprises at least a transmitter for the wireless transmission of measured signals.

3. A device as set forth in claim 1, wherein the textile substrate comprises a second component structurally more rigid than the textile substrate, and wherein said second component structurally more rigid than the textile substrate is provided on top of the base structure component.

4. A device as set forth in claim 3, wherein between said substrate and the second component provided on top of the base structure component of the electronics is only a mechanical connection, but no electrical connections.

5. A device as set forth in claim 3, wherein said second component is designed to be removable.

6. A device as set forth in claim 3, wherein said second component is at least partially coated with textile.

7. A device as set forth in claim 1, wherein said textile substrate is a heart rate belt, a band, or a garment.

8. A device as set forth in claim 1, wherein elements integrated irremovably with a region of the textile substrate comprising the electronics or the structure more rigid than the textile substrate, are attached by a process selected from the group chosen from injection molding, gluing, sewing, screws, upsetting, ultrasonic welding, high frequency lamination and heat lamination.

9. The device as set forth in claim 1, wherein the device is a wearable article.

10. The device as set forth in claim 9, wherein the textile substrate comprises a second component structurally more rigid than the textile substrate, and wherein the second component is a protective cover and said protective cover is designed to be removable.

8

11. The device of claim 9, the wearable article chosen from a heart rate belt, a heart rate band and a garment.

12. The device of claim 9, the wearable article comprising a garment chosen from a shirt, a bra, a sports accessory, an undergarment, a sock and a pair of pants.

13. The device as set forth in claim 1, wherein said textile substrate is a garment chosen from a shirt, a bra, a sports accessory, an undergarment, a sock and a pair of pants.

14. A method for manufacturing a device comprising a textile substrate, said method comprising:

providing a textile substrate with measuring sensors for measuring a physiological signal,

providing signal transfer conductors which are coupled with and extended from the measuring sensors along the textile substrate; and

providing a base structure component of physiological signal processing or transmitting electronics,

wherein the base structure component is more rigid than the textile substrate and is irremovably and permanently integrated into the textile substrate,

wherein said base structure component comprises signal transfer elements for connecting said electronics to the signal transfer conductors, and

wherein the signal transferring from the measuring sensors to the electronics is implemented by electrically coupling the signal transfer conductors from the textile substrate to the signal transfer elements of said base structure component and thereby enabling signal transferring through said base structure component to the electronics in an irremovably, permanently integrated and watertight manner.

15. A method as set forth in claim 14, further comprising integrating said base structure component of the electronics to the textile substrate by a process selected from the group chosen from injection molding, gluing, sewing, screws, upsetting, ultrasonic welding, high frequency lamination and heat lamination.

\* \* \* \* \*

专利名称(译)	用于测量物理量的纺织基材		
公开(公告)号	<a href="#">US9782096</a>	公开(公告)日	2017-10-10
申请号	US13/982448	申请日	2012-01-31
[标]申请(专利权)人(译)	JAAKKOLA HEIKKI tuulenmaki汤米 ReHo值AKSELI		
申请(专利权)人(译)	JAAKKOLA , HEIKKI TUULENMAKI , TOMMI ReHo值 , AKSELI		
当前申请(专利权)人(译)	服装PLUS MBU OY		
[标]发明人	JAAKKOLA HEIKKI TUULENMAKI TOMMI REHO AKSELI		
发明人	JAAKKOLA, HEIKKI TUULENMAKI, TOMMI REHO, AKSELI		
IPC分类号	A61B5/0408 A61B5/0245 A61B5/024 H01R13/52 A61B5/00 A61B5/04		
CPC分类号	A61B5/04085 A61B5/0002 A61B5/0245 A61B5/02438 A61B5/0408 A61B5/6804 A61B5/6807 H01R13/5213 A61B5/04 Y10T29/49002 H01R13/5224		
代理机构(译)	、凯尼格、P.C.		
优先权	2011005094 2011-01-31 FI		
其他公开文献	US20140024915A1		
外部链接	<a href="#">Espacenet</a> <a href="#">USPTO</a>		

摘要(译)

一种纺织基质，具有用于测量生理信号的测量传感器。纺织品基底不可拆卸地与其一起集成用于电子器件的基础结构部件，例如用于发射器的塑料基座，用于通过所述基部结构部件不可拆卸地将发射器和其他电子器件连接到基板。另外，来自测量传感器的信号传递元件适于通过与织物基底不可移除地集成的所述基础结构部件以水密方式延伸到电子器件。

