



US 20080064942A1

(19) **United States**

(12) **Patent Application Publication** (10) **Pub. No.: US 2008/0064942 A1**
Gisiger et al. (43) **Pub. Date: Mar. 13, 2008**

(54) **METHOD FOR MEASURING THE
TRANSCUTANEOUS CO2 PARTIAL
PRESSURE ON AN EAR LOBE**

(30) **Foreign Application Priority Data**

May 18, 2004 (CH) 867/04

Publication Classification

(76) Inventors: **Pierre-Alain Gisiger**, Laufen (CH);
Dominik Liechty, Reinach (CH);
Patrick Eberhard, Bottmingen (CH);
Sohei Kagawa, Tokyo (JP)

(51) **Int. Cl.**
A61B 5/1491 (2006.01)

(52) **U.S. Cl.** **600/354**

(57) **ABSTRACT**

In a process for measuring partial transcutaneous CO₂ pressure on an earlobe by means of a sensor having a measuring device for measuring the partial transcutaneous CO₂ pressure and a heating system for heating a sensor contact surface for contact with the earlobe, the sensor contact surface is heated. During a first phase, the sensor contact surface is kept at an elevated temperature of at least 41.5° C. in order to prevent the measured value of partial transcutaneous CO₂ pressure from exceeding, due to the measurement process itself, the partial transcutaneous CO₂ pressure achieved after stabilization. The temperature of the sensor contact surface is then reduced to between 37° C. and 41° C. This facilitates considerably faster evaluation of the measured values.

Correspondence Address:
MORGAN LEWIS & BOCKIUS LLP
1111 PENNSYLVANIA AVENUE NW
WASHINGTON, DC 20004 (US)

(21) Appl. No.: **11/596,873**

(22) PCT Filed: **May 12, 2005**

(86) PCT No.: **PCT/CH05/00265**

§ 371(c)(1),
(2), (4) Date: **Nov. 17, 2006**

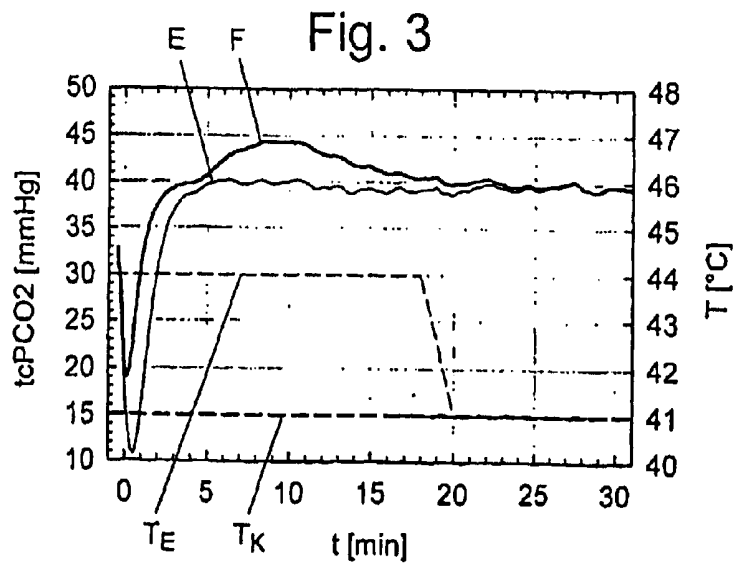
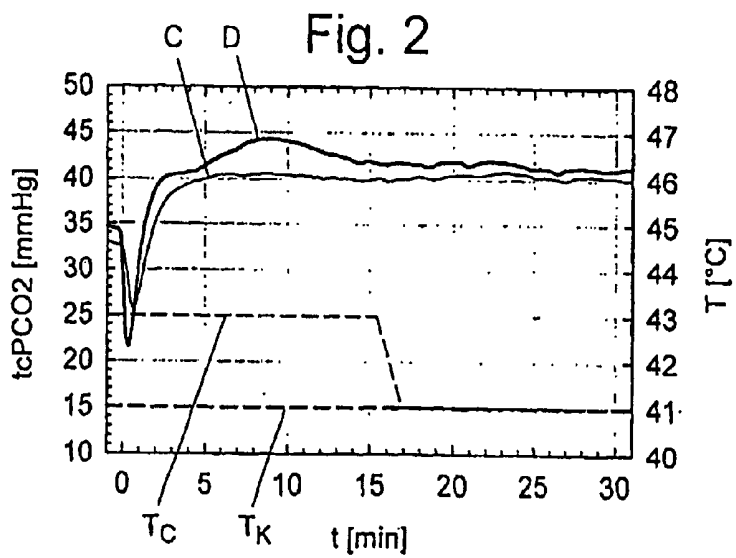
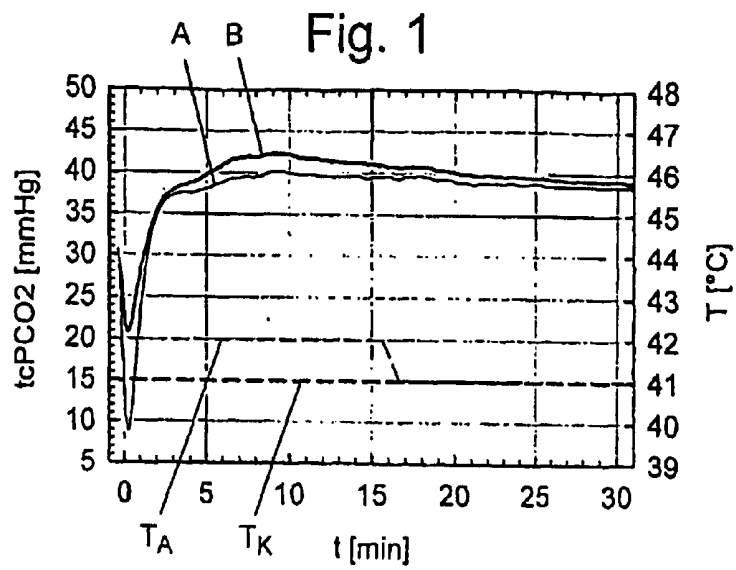

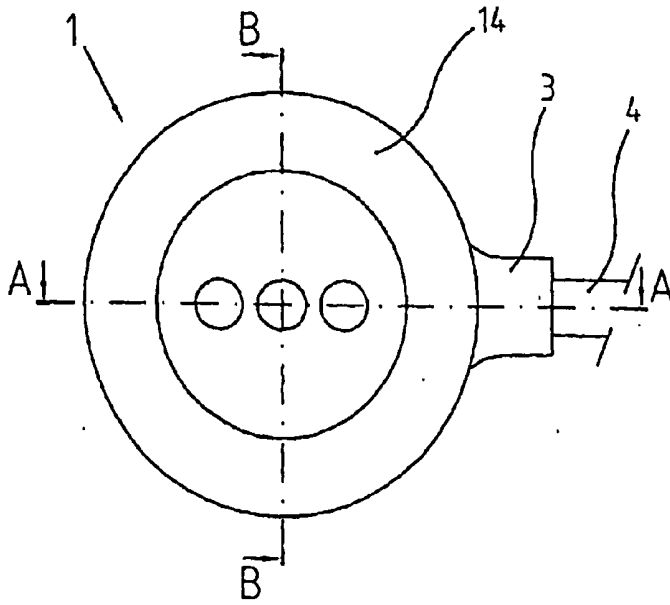

Fig. 4

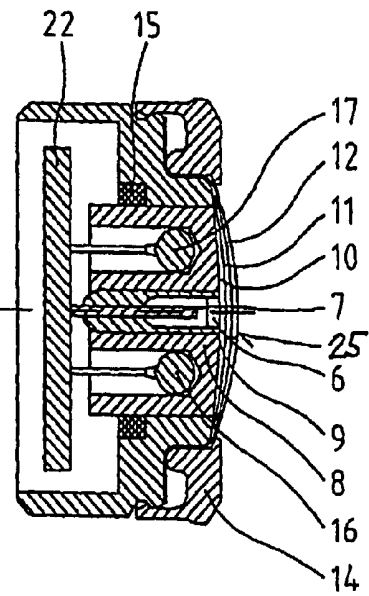

Fig. 6

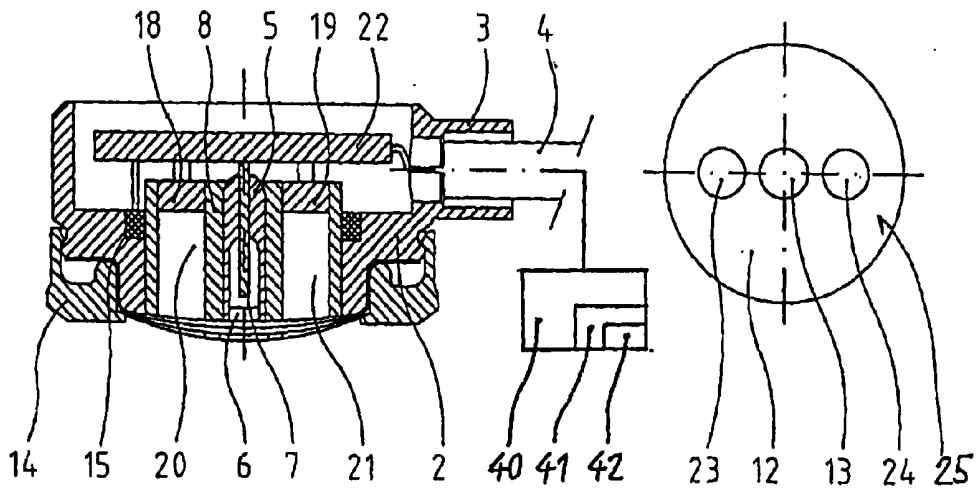

Fig. 5

Fig. 7

**METHOD FOR MEASURING THE
TRANSCUTANEOUS CO₂ PARTIAL PRESSURE ON
AN EAR LOBE**

[0001] The present invention refers to a method for measuring the transcutaneous partial pressure of carbon dioxide on an ear lobe, as defined in the preamble of the independent patent claim 1 and to a sensor for implementing this method, as defined in the preamble of the independent patent claim 8.

[0002] In order to be able to evaluate the respiratory functions of a patient it is often necessary to know the arterial partial pressure of CO₂ (paCO₂). There are various methods available today for measurement of the paCO₂ value, one of which includes measurement of the transcutaneous CO₂ partial pressure (tcpCO₂). This indirect method makes use of the fact that CO₂ diffuses easily through body tissues and skin. The gas is measured with a sensor applied to the surface of the skin, which is equipped with a heating element for heating the area of skin on which the sensor rests. If the sensor contact surface is heated to a temperature of about 40° C. to 44° C., then a local dilation and arterIALIZATION of the capillary bed is produced at the measurement site. Under these conditions, the transcutaneous CO₂ partial pressure measured there shows a high correlation with the arterial value. This makes it possible, with certain restrictions, to determine the paCO₂ value with sufficient accuracy for most applications.

[0003] Determining of the paCO₂ value by measurement of the transcutaneous CO₂ partial pressure offers several advantages: the measurement is non-invasive, continuous and may also be used with patients who are not intubated.

[0004] A method and a sensor for measurement of the transcutaneous CO₂ partial pressure on an earlobe as an advantageous measurement site are described in U.S. Pat. No. 6,654,622. In this, the sensor is attached on the earlobe using a clip or an adhesive strip. This requires no particular effort, and the measurement site is at a physiologically central place and is easily accessible and well visible, for example, for an anesthesiologist during surgery. Furthermore, hindrance of the operating surgeon or problems with respect to sterility requirements is extremely rare.

[0005] However, during measurements of the transcutaneous CO₂ partial on earlobes of patients with the sensors described in U.S. Pat. No. 6,654,622, unexpectedly high measurement values were recorded during the first 20 minutes with the sensor contact area at a temperature of approx. 41° C. The relevant measurement plots show an initial overshooting of the measurement values which begins about 5 minutes after application of the sensor and starts to decrease after about another 5 minutes until it is finally no longer observed approximately 20 minutes after the measurement is started. Direct comparative measurements of the arterial CO₂ partial pressure on blood samples taken show that approximately 20 minutes after the start of measurement the expected measurement values of the transcutaneous CO₂ partial pressure are achieved.

[0006] This overshooting of the transcutaneous CO₂ partial pressure in approximately the first 20 minutes after measurements are started means that the measurement values during this time cannot simply be used for the determination of the arterial CO₂ partial pressure. The arterial CO₂

partial pressure can therefore be determined using this known method for measuring the transcutaneous CO₂ partial pressure only after a relatively long start-up phase.

[0007] Therefore, the objective of the present invention is to provide a method for measuring the transcutaneous CO₂ partial pressure on an ear lobe in which the transcutaneous CO₂ partial pressure values measured are already usable for reliable determination of the arterial CO₂ partial pressure after a comparatively short start-up phase. Furthermore, a sensor should be provided with which such a method can be implemented.

[0008] This objective is accomplished by the inventive method and inventive sensor as defined in the independent patent claims 1 and 9. Patent claim 8 refers to an inventive method for preventing an overshoot of the transcutaneous CO₂ partial pressure in the skin of an earlobe over the CO₂ partial pressure achieved after stabilization during the arterialization of the skin. Preferred embodiments are provided in the dependent patent claims.

[0009] The invention can be characterized as follows: in a method for measuring the transcutaneous CO₂ partial pressure on an ear lobe the measurement takes place by means of a sensor, which has a measuring device for measurement of the transcutaneous CO₂ partial pressure and a heating element for heating a sensor contact surface intended for application on the earlobe. With this method the sensor contact surface is heated. The sensor contact surface is maintained at an elevated temperature of at least 41.5° C. during an initial phase to prevent a measurement-related overshoot of the measured value of the transcutaneous CO₂ partial pressure over the transcutaneous CO₂ partial pressure achieved after stabilization. Afterward, the temperature of the sensor contact surface is reduced to between 37° C. and 41° C.

[0010] Because the sensor contact surface is maintained at an elevated temperature of at least 41.5° C. during an initial phase, overshooting of the measurement value of the transcutaneous CO₂ partial pressure over the transcutaneous CO₂ partial pressure achieved after stabilization can be prevented. In this way, useful measurements are much faster achieved. The subsequent lowering of the temperature of the sensor contact surface to between 37° C. and 41° C. ensures that the patient suffers no burns at the measurement site.

[0011] It is assumed that the initial overshoot of the measurement value for the transcutaneous CO₂ partial pressure during measurements with a sensor contact surface temperature between about 37° C. and 41° C. is because the skin touching the sensor contact surface is in fact warmed quickly, which increases the local metabolism and thus leads to an increased release of CO₂, but that the cutaneous vasodilatation occurs later. This means that the metabolically produced CO₂ is only removed by the blood vessels later and the transcutaneous CO₂ partial pressure is initially in excess. Furthermore, the overshoot of the transcutaneous CO₂ partial pressure measurement could also be brought about or intensified by CO₂ stored in the skin.

[0012] After the preheating it is advantageous that the elevated temperature be reduced by at least 1° C., preferably by at least 2° C. This enables the selection of a sufficiently high increased temperature for the first phase without causing skin burns in the second phase after the temperature is decreased.

[0013] Preferably the elevated temperature is in the range of 41.5° C. to 44° C. This is sufficient to prevent an initial overshoot of the measurement value of the transcutaneous CO₂ partial pressure without the risk of skin burns during the relatively short initial phase.

[0014] It is advantageous that the initial phase with the elevated temperature, during which the sensor contact surface is applied on the earlobe, lasts between 5 and 60 minutes. Five minutes of increased temperature are sufficient in most cases to prevent an overshoot in the measurement of the transcutaneous CO₂ partial pressure. If 60 minutes of increased temperature are not exceeded, skin burns are practically excluded.

[0015] Preferably the first phase with the elevated temperature lasts between 6 and 30 minutes. In this way an overshoot of the transcutaneous CO₂ partial pressure measurement is effectively prevented. More than 30 minutes of elevated temperature offer no advantage in this regard. An optimal duration of the initial phase is considered to be between 6 and 15 minutes. An unnecessarily long initial phase has no advantage.

[0016] In a preferred embodiment the initial phase lasts between 6 and 30 minutes, and the elevated temperature is at least 42° C. In this way an overshoot of the transcutaneous CO₂ partial pressure is effectively prevented, and the elevated temperature is not maintained too long.

[0017] It is advantageous that the elevated temperature be approximately 44° C. and the first phase preferably last between 6 and 20 minutes. These conditions ensure that the measurement value of the transcutaneous CO₂ partial pressure will not overshoot in any case.

[0018] It is advantageous that the reduction of the temperature of the sensor contact surface take place at a rate of less than or equal to 1° C. per 10 seconds, preferably less than or equal to 1° C./min. If the temperature is lowered too quickly, a small peak may occur in the measurement curve. This means that measurements of the transcutaneous CO₂ partial pressure are influenced by the temperature reduction in such a way that their use for determining the arterial CO₂ partial pressure leads to imprecise results.

[0019] A further aspect of the invention consists of a method for prevention an increase of the transcutaneous CO₂ partial pressure in the skin of an earlobe over the CO₂ partial pressure achieved after stabilization during the arterialization of the skin during measurement of the transcutaneous CO₂ partial pressure. With this method the skin at a measurement site for the transcutaneous CO₂ partial pressure is maintained at an elevated temperature of at least 41.5° C. during an initial phase, and afterward the temperature of the skin is reduced to between 37° C. and 41° C.

[0020] As mentioned already above, during measurement of the transcutaneous CO₂ partial pressure on an earlobe, in which the sensor contact surface is heated to a temperature of between about 37° C. and 41° C., the skin touching the sensor contact surface warms more rapidly than cutaneous vasodilatation, i.e. arterialization of the skin, occurs. This means that the metabolically produced CO₂ is only removed by the blood vessels later and the transcutaneous CO₂ partial pressure is initially in excess. Furthermore, CO₂ is also stored in the skin; this increases the transcutaneous CO₂ partial pressure at first. The inventive solution counteracts

this by maintaining the skin at a measurement site for the transcutaneous CO₂ partial pressure at an elevated temperature of at least 41.5° C., and afterward the skin temperature is reduced to between 37° C. and 41° C.

[0021] A sensor according to the invention has a measuring device for measurement of the transcutaneous CO₂ partial pressure and a heating element for heating of a sensor contact surface intended for application on an earlobe. Furthermore, it has a heater control with a timer, which reduces the heater power of the heating element after a predefined time so that the temperature of the sensor contact surface is reduced. The inventive method may be implemented with such a sensor, bringing the advantages cited.

[0022] It is advantageous that the predefined time after which the heater control reduces the heater power of the heating element be adjustable. This makes it possible to adjust the duration of the initial phase of elevated temperature, for example, as appropriate for the patient or patient group with which the sensor is applied. Thus, for example, it is conceivable that the initial phase for newborn infants be chosen to be shorter than for adults.

[0023] The measurement of the transcutaneous CO₂ partial pressure itself is based in general on an electrochemical principle. It is usually done potentiometrically by measuring the pH value of a thin layer of electrolyte solution, which is contacted with the skin via a hydrophobic membrane that is highly permeable to gas. A change of the transcutaneous CO₂ partial pressure on the skin surface causes a pH change of the electrolyte solution, which is proportional to the logarithm of the tcpCO₂ change. The pH value is determined, for example, by measuring the potential between a miniature pH glass electrode and a silver/silver chloride reference electrode. However, the present invention is not limited to this measurement procedure, but may rather be applied to any other methods for measuring the transcutaneous CO₂ partial pressure.

[0024] The inventive method and inventive sensor are described below with reference to the drawings included, based on embodiments. These show in

[0025] FIG. 1—a chart with measurement curves for measurements of the transcutaneous CO₂ partial pressure on two earlobes of a test subject using sensors with sensor contact areas for which on one earlobe the sensor contact surface of the sensor is maintained at an elevated temperature of 42° C. during an initial phase;

[0026] FIG. 2—a chart with further measurement curves for measurements of the transcutaneous CO₂ partial pressure on two earlobes of the same test subject in which on one earlobe the sensor contact surface of the sensor is maintained at an elevated temperature of 43° C. during an initial phase;

[0027] FIG. 3—a chart with further measurement curves for measurements of the transcutaneous CO₂ partial pressure on two earlobes of the same test subject in which on one earlobe the sensor contact surface of the sensor is maintained at an elevated temperature of 44° C. during an initial phase;

[0028] FIG. 4—a schematic top view of an inventive sensor for the measurement of the transcutaneous CO₂ partial pressure and a pulse oximetric measurement of arterial oxygen saturation;

[0029] FIG. 5—a section view of the sensor cut along line A-A in FIG. 4;

[0030] FIG. 6—a section view of the sensor cut along line B-B in FIG. 4 and

[0031] FIG. 7—a top view of the sensor contact surface intended to be placed on an earlobe.

[0032] In the FIGS. 1-3, the X-axis of the charts represents the time in minutes, the left Y-axis is the partial pressure in mm Hg, and the temperature in degrees centigrade is specified on the right Y-axis.

[0033] On an earlobe of a test subject, the transcutaneous CO₂ partial pressure was measured in each case with a sensor in which the contact surface of the sensor was maintained at a constant temperature of 41° C. This constant temperature is represented in each case as a dashed horizontal straight line T_K. The corresponding measurements of the transcutaneous CO₂ partial pressure resulted in the measurement curve B in FIG. 1, the measurement curve D in FIG. 2 and the measurement curve F in FIG. 3. With all three of these measurement curves B, D and F it can be seen that the measurement values at first fall sharply from approximately 28-35 mm Hg to about 18-23 mm Hg, and after that rise to a peak of about 42-45 mm Hg, before they slowly drop to an approximately stable value of between 38 and 42 mm Hg.

[0034] The initial sharp decrease of the measurement values displayed results from removing the sensor from a calibration chamber and placing it on the earlobe. This means that the measurements for the first 3 to 5 minutes are not due to physiological conditions and therefore cannot be used for determining the arterial CO₂ partial pressure.

[0035] After that, overshooting occurs for the measurement values of the transcutaneous CO₂ partial pressure over the approximately stable value finally achieved; as explained above, this may be ascribed to the fact that the skin of the earlobe in contact with the sensor contact surface does in fact warm quickly, leading to an increase in the local metabolism and thus an increased release of CO₂, but cutaneous vasodilatation occurs later. This means that the metabolically produced CO₂ in the skin is only removed by the blood vessels later and the transcutaneous CO₂ partial pressure is initially in excess. Furthermore, the overshoot of the transcutaneous CO₂ partial pressure measurement could also be brought about or intensified by CO₂ stored in the skin.

[0036] In order to prevent this overshooting, in accordance with the invention the sensor contact surface of the sensor on the other earlobe of the test subject was maintained at an elevated temperature of 42° C., 43° C. and 44° C. respectively during an initial phase, and the temperature of the sensor contact surface was reduced to 41° C. only after this initial phase was over. For the measurement displayed in FIG. 1, the first phase lasted approximately 16 minutes and the temperature of the sensor contact surface (dashed temperature curve, T_A) was 42° C. during this time. Afterward, the temperature of the sensor contact surface was reduced by 1° C. within a minute. For the measurement displayed in FIG. 2, the first phase lasted approximately 15.5 minutes and the temperature of the sensor contact surface (dashed temperature curve, T_C) was 43° C. during this period. Afterward, the temperature of the sensor contact surface was

reduced by 2° C. within one and a half minutes. For the measurement displayed in FIG. 3, the first phase lasted approximately 18 minutes and the temperature of the sensor contact surface (dashed temperature curve, T_E) was 44° C. during this period. Afterward, the temperature of the sensor contact surface was reduced by 3° C. within two minutes.

[0037] The measurement values of the transcutaneous CO₂ partial pressure associated with the temperature curves T_A, T_C and T_E resulted in the measurement curve A in FIG. 1, the measurement curve C in FIG. 2 and the measurement curve E in FIG. 3. For all three of these measurement curves A, C and E it can be seen that the measurements first drop sharply from 30-35 mm Hg to about 8-28 mm Hg, and thereafter rise rapidly to an approximately stable value between about 38 and 42 mm Hg. An overshoot of the measurements of the transcutaneous CO₂ partial pressure above the final approximately stable value reached is not to be seen. This means that the measurements are already usable after a relatively short warm-up phase of approximately 5 minutes.

[0038] FIGS. 4-7 show an embodiment of an inventive sensor for measurement of the transcutaneous CO₂ partial pressure, which may simultaneously perform a pulse oximetric measurement of arterial oxygen saturation. FIG. 4 shows a top view of a sensor 1, in which the cut surfaces of the cross section views for FIGS. 5 (A-A) and 6 (B-B) are drawn. The sensor head consists of a round housing 2 made of plastic with a neck-shaped extension 3, through which the connecting wires 4 are led out in FIG. 5 to a schematically represented measurement device 40. The components required for the measuring functions and the various electronic components described below are contained in the housing.

[0039] A glass pH electrode 5 is found in the centerline of the sensor. It consists of a cylindrical glass shaft onto the front side of which a pH-sensitive glass layer 6 has been fused. In the interior of the glass cylinder there is an internal reference electrode with a platinum lead-in wire 7 fused in the glass. The pH electrode 5 is embedded in a silver block 8 whose surface is covered with a chloride layer 9. The surface of the silver block thus forms an Ag/AgCl electrode, which serves as a reference electrode for the pH measurement. An electrolyte solution the pH value of which is measured is located in a porous, hydrophilic spacer 10, which is covered with a gas-permeable, hydrophobic membrane 11 (such as Teflon). To protect the membrane from mechanical damage it is covered with a metal faceplate 12. This faceplate has an opening 13 in the middle (over the pH-sensitive glass layer 6), through which the CO₂ gas to be measured can diffuse in the electrolyte solution in the area of the pH-sensitive glass layer. The spacer 10, the membrane 11 and the metal faceplate 12 are fastened to the sensor casing 2 by means of a tension ring 14. The silver block 8 also functions as a heater. It is wrapped like a spool with a heating wire 15, by means of which it is heated to a temperature between 37° C. and 45° C., which is required for the transcutaneous measurement. As can be seen in FIG. 6, there are two thermistors 16 and 17 embedded in two bore holes within the silver block 8. These thermistors 16, 17 serve to regulate and control the selected sensor temperature. The temperature of the sensor contact surface, which is usually lower, may be calculated from the temperature measured by the thermistors 16, 17. The temperature gra-

dient to be used in the calculation may be determined beforehand by measuring the temperature at the sensor contact surface, in which case the temperature measurement follows the international standard IEC 60601-2-23, Clause 42.3.104.

[0040] The optical components required for the pulse oximetric measurement can be seen in the cross section of FIG. 5. These are two LEDs **18** mounted directly adjacent to one another on a ceramic substrate, and a photodiode **19**. The light from and to these components is channeled by two cylindrical light channels **20** and **21**, which consist of two holes in the silver block filled with translucent material.

[0041] All electrical connections from and to the various components are run in an electronic unit **22**, in which part of the signal processing is already performed. The connecting wires **4** to the measurement device **40** originate from this electronic unit and, as described, pass through the sensor neck **3** to the outside. The measurement device **40** has a heating control unit **41** with a timer **42**, which in accordance with the invention may reduce the heater power of the heater constituted by the silver block **8** and the heating wire **15** after an adjustable, pre-determined time period.

[0042] Eventually, FIG. 7 shows a top view of the metal faceplate **12**, which forms the actual contact surface **25** of the sensor. As already mentioned, a perforation **13** is located in the center of the faceplate, through which the carbon dioxide gas can reach the electrolyte at the pH electrode. The two perforations **23** and **24** arranged on the periphery permit the outgoing light from the LED and scattered light from the tissue to pass through.

[0043] Further embodiments of the inventive method and sensors described above can be implemented. It is explicitly noted here that the sensor, of course, need not have components for performing a pulse oximetric measurement of the arterial oxygen saturation. Furthermore, the entire electronics for measurement may also be situated in the sensor head itself.

1. A method for measurement of the transcutaneous CO₂ partial pressure on an ear lobe by means of a sensor (1) which has a measuring device for measurement of the transcutaneous CO₂ partial pressure and a heating element (8, 15) for warming a sensor contact surface (25) intended for contact with the ear lobe, and during said method the sensor contact surface (25) is heated, characterized in that the sensor contact surface (25) is maintained at an elevated temperature of at least 41.5° C. during an initial phase to

prevent a measurement-related overshoot of the measured value of the transcutaneous CO₂ partial pressure over the transcutaneous CO₂ partial pressure achieved after stabilization, and afterward the temperature of the sensor contact surface (25) is reduced to between 37° C. and 41° C.

2. A method according to claim 1, characterized in that the temperature is decreased by at least 1° C., preferably at least by 2° C.

3. A method according to claim 1 or 2, characterized in that the elevated temperature is in the range of 41.5° C. to 44° C.

4. A method according to claim 1, characterized in that the initial phase with the elevated temperature, during which the sensor contact surface (25) is applied to the earlobe, lasts between 5 and 60 minutes, preferably between 6 and 30 minutes, especially between 6 and 15 minutes.

5. A method according to claim 4, characterized in that the initial phase lasts between 6 and 30 minutes and the elevated temperature is at least 42° C.

6. A method according to claim 5, characterized in that the elevated temperature is approx. 44° C. and the initial phase preferably lasts between 6 and 20 minutes.

7. A method according to claim 1, characterized in that the reduction of the temperature of the sensor contact surface (25) occurs at a rate of less than or equal to 1° C. per 10 seconds, preferably less than or equal to 1° C./min.

8. A method for prevention an increase of the transcutaneous CO₂ partial pressure in the skin of an earlobe over the CO₂ partial pressure achieved after stabilization during the arterialization of the skin with the measurement of the transcutaneous CO₂ partial pressure, during which the skin at a measurement site for the transcutaneous CO₂ partial pressure is maintained at an elevated temperature of at least 41.5° C. during an initial phase and afterward the temperature of the skin is reduced to between 37° C. and 41° C.

9. A sensor (1) for implementation of the method according to claim 1, which has a measuring device for measuring the transcutaneous CO₂ partial pressure and a heating element (8, 15) for heating a sensor contact surface (25) intended for contact with an earlobe, characterized in that it has a heater control (41) with a timer (42) which reduces the heating power of the heating element (8, 15) after a pre-defined period, so that the temperature of the sensor contact surface (25) is reduced.

10. A sensor according to claim 9, characterized in that the pre-defined period after which the heater control (41) reduces the heating power of the heater (8, 15) is adjustable.

* * * * *

专利名称(译)	测量耳垂上经皮二氧化碳分压的方法		
公开(公告)号	US20080064942A1	公开(公告)日	2008-03-13
申请号	US11/596873	申请日	2005-05-12
[标]申请(专利权)人(译)	GISIGER PIERRE ALAIN LIECHTY DOMINIK EBERHARD PATRICK KAGAWA 僧兵		
申请(专利权)人(译)	GISIGER PIERRE-ALAIN LIECHTY DOMINIK EBERHARD PATRICK KAGAWA 僧兵		
当前申请(专利权)人(译)	RADIOMETER BASEL AG		
[标]发明人	GISIGER PIERRE ALAIN LIECHTY DOMINIK EBERHARD PATRICK KAGAWA SOHEI		
发明人	GISIGER, PIERRE-ALAIN LIECHTY, DOMINIK EBERHARD, PATRICK KAGAWA, SOHEI		
IPC分类号	A61B5/1491 A61B5/00		
CPC分类号	A61B5/14539 A61B5/14542 A61B5/1491 A61B5/1477 A61B5/14552		
优先权	2004000867 2004-05-18 CH		
其他公开文献	US7474908		
外部链接	Espacenet USPTO		

摘要(译)

在通过具有用于测量部分经皮CO₂压力的测量装置的传感器和用于加热传感器接触表面以与耳垂接触的加热系统测量耳垂上的部分经皮CO₂压力的过程中，传感器接触表面被加热。在第一阶段期间，传感器接触表面保持在至少41.5°C的高温下，以防止部分经皮CO₂压力的测量值由于测量过程本身而超过实现的部分经皮CO₂压力。稳定后，然后将传感器接触表面的温度降低到37°C和41°C之间。这有助于显著更快地评估测量值。

