



(19) **United States**

(12) **Patent Application Publication**
Yoo

(10) **Pub. No.: US 2005/0058456 A1**

(43) **Pub. Date: Mar. 17, 2005**

(54) **PHOTOPLETHYSMOGRAPHY (PPG)
DEVICE AND THE METHOD THEREOF**

Publication Classification

(51) **Int. Cl.⁷ H04B 10/00**

(52) **U.S. Cl. 398/140**

(76) **Inventor: Sun Kook Yoo, Seoul (KR)**

(57) **ABSTRACT**

Correspondence Address:
**OBLON, SPIVAK, MCCLELLAND, MAIER &
NEUSTADT, P.C.**
1940 DUKE STREET
ALEXANDRIA, VA 22314 (US)

A method of measuring Photoplethysmography (PPG) signals may comprise detecting dual wavelength illumination from a light detector so as to provide detected signals, converting the detected signals into digital signals so as to provide digital signals, reducing noises from the digital signals and increasing independency between the digital signals so as to provide preprocessed signals, subtracting the average value from the preprocessed signals so as to provide adjusted signals, obtaining whitening matrix based on covariance, eigen value, and eigen matrix obtained from the adjusted signals, and restoring data using the whitening matrix.

(21) **Appl. No.: 10/884,957**

(22) **Filed: Jul. 7, 2004**

(30) **Foreign Application Priority Data**

Jul. 7, 2003 (KR) 10-2003-0045673

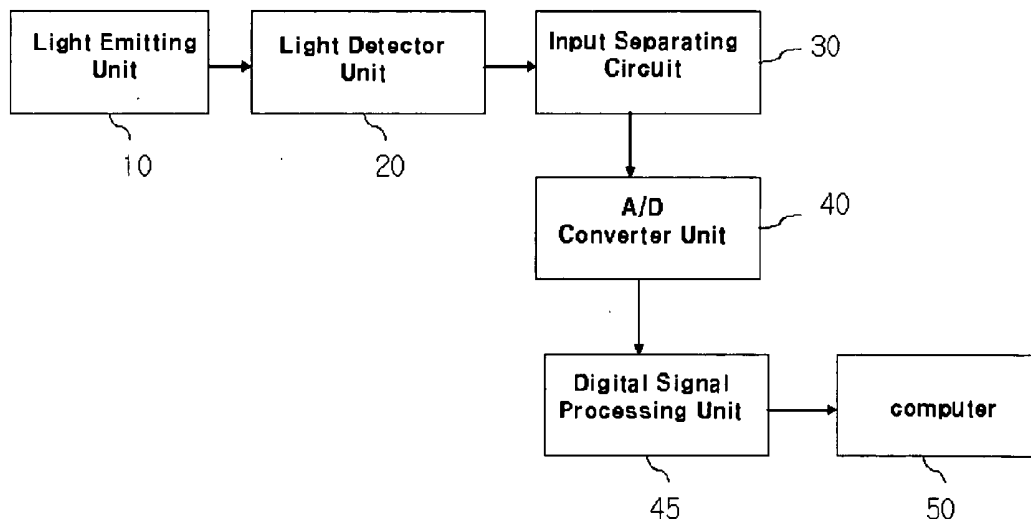

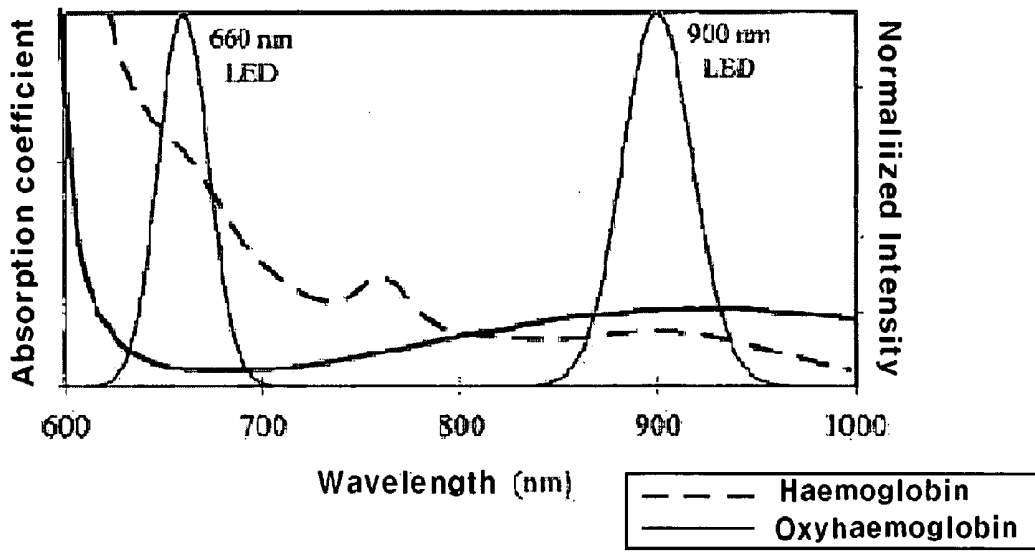

FIG. 1

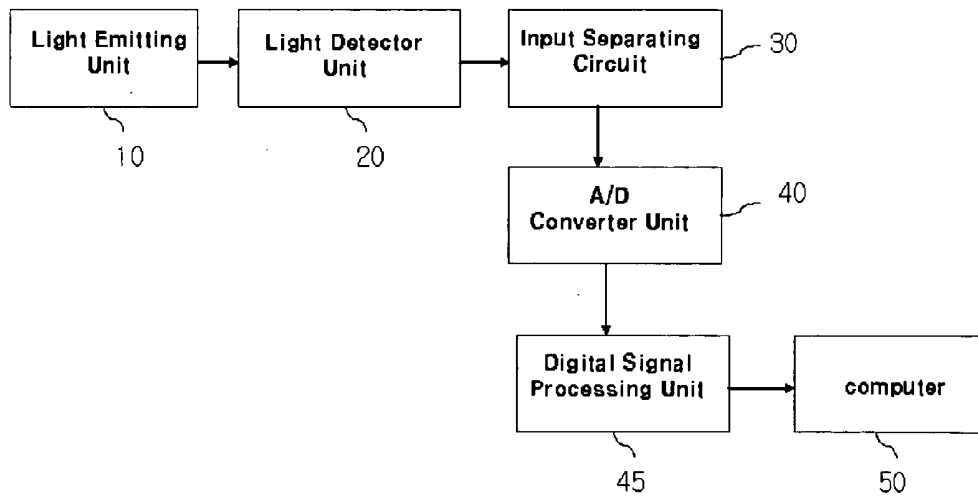

FIG. 2

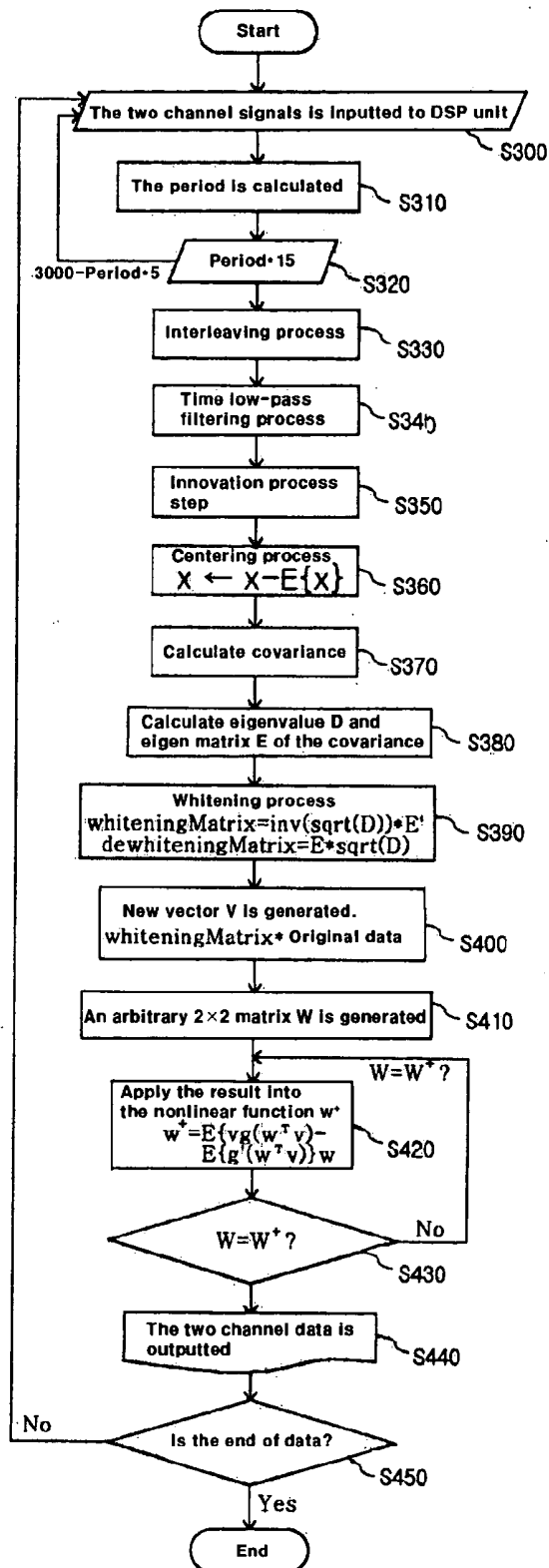

FIG. 3

FIG. 4

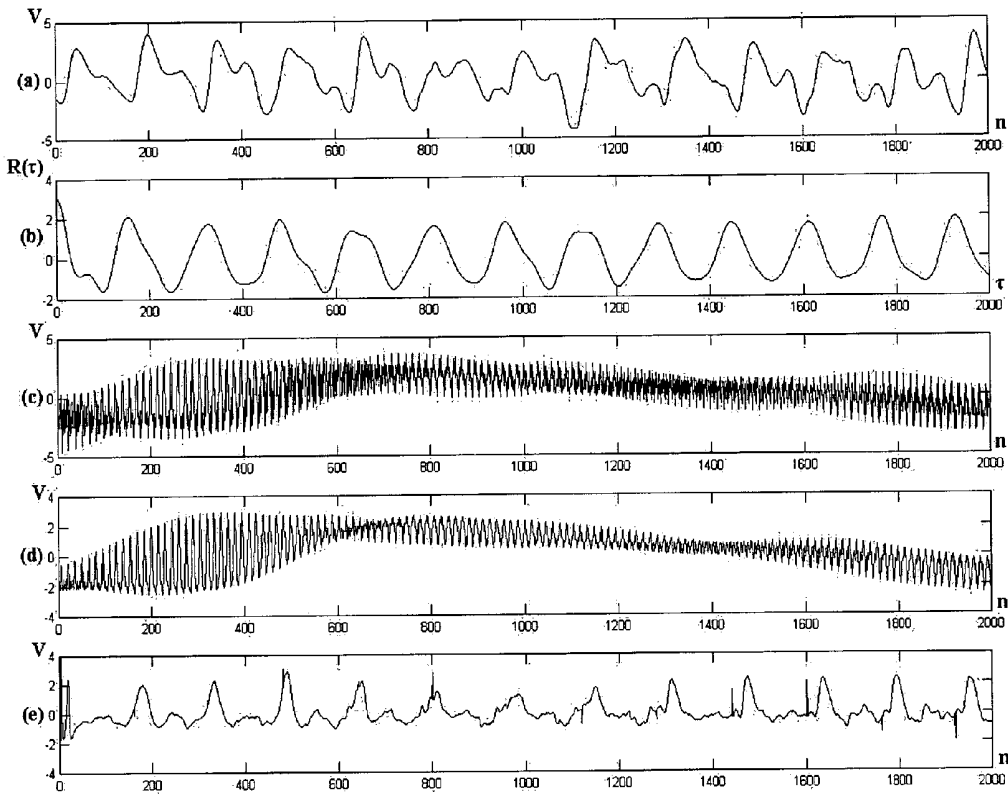

FIG. 5

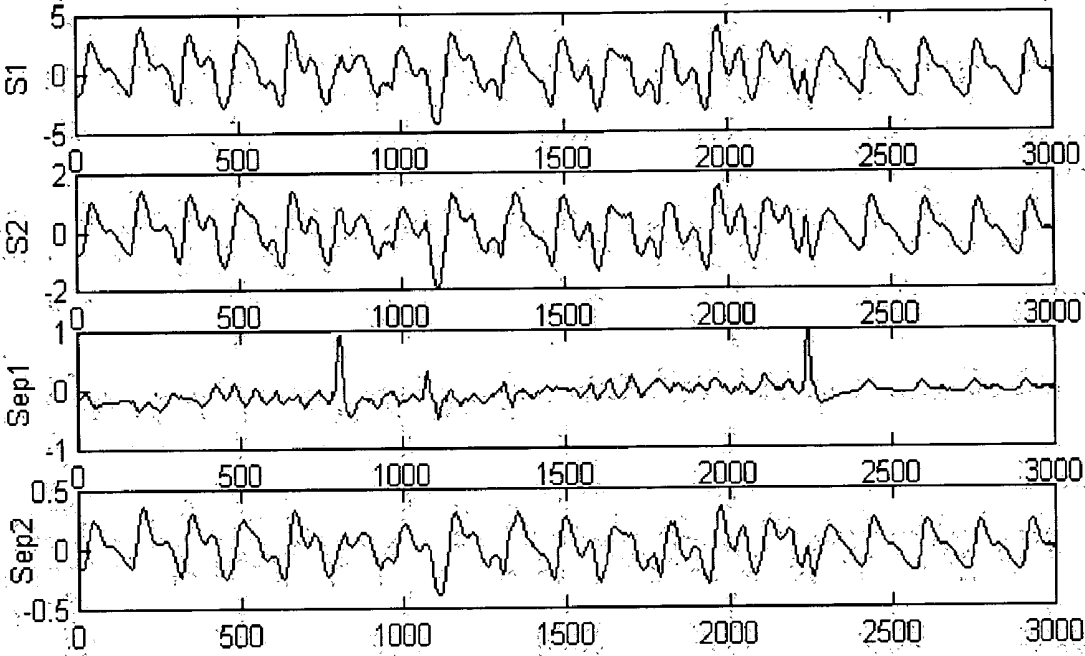

FIG. 6

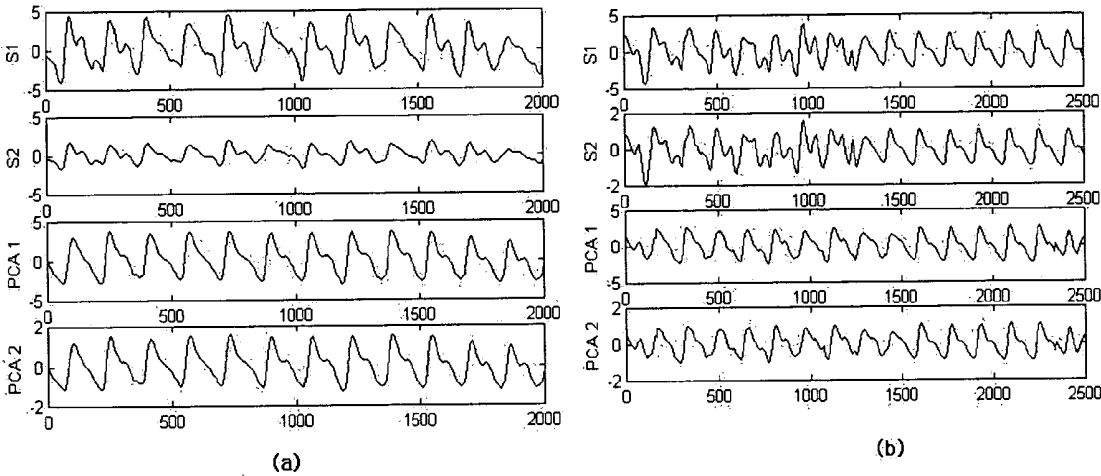

FIG. 7

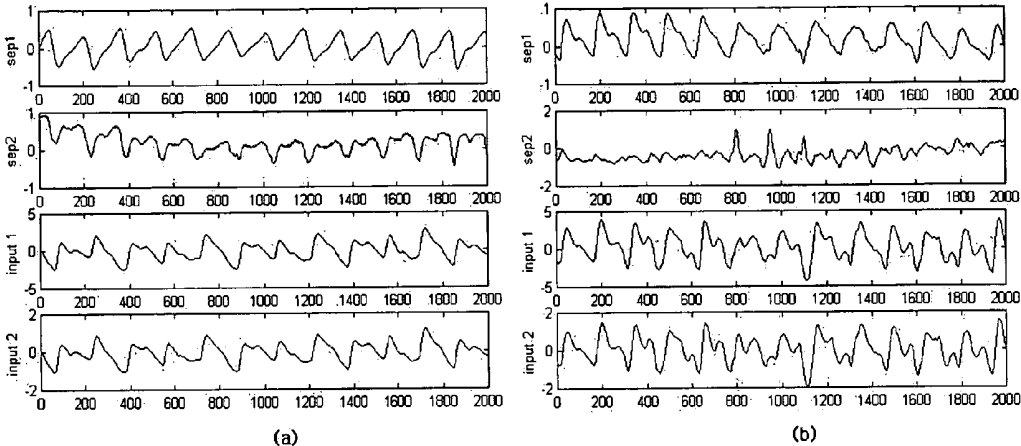
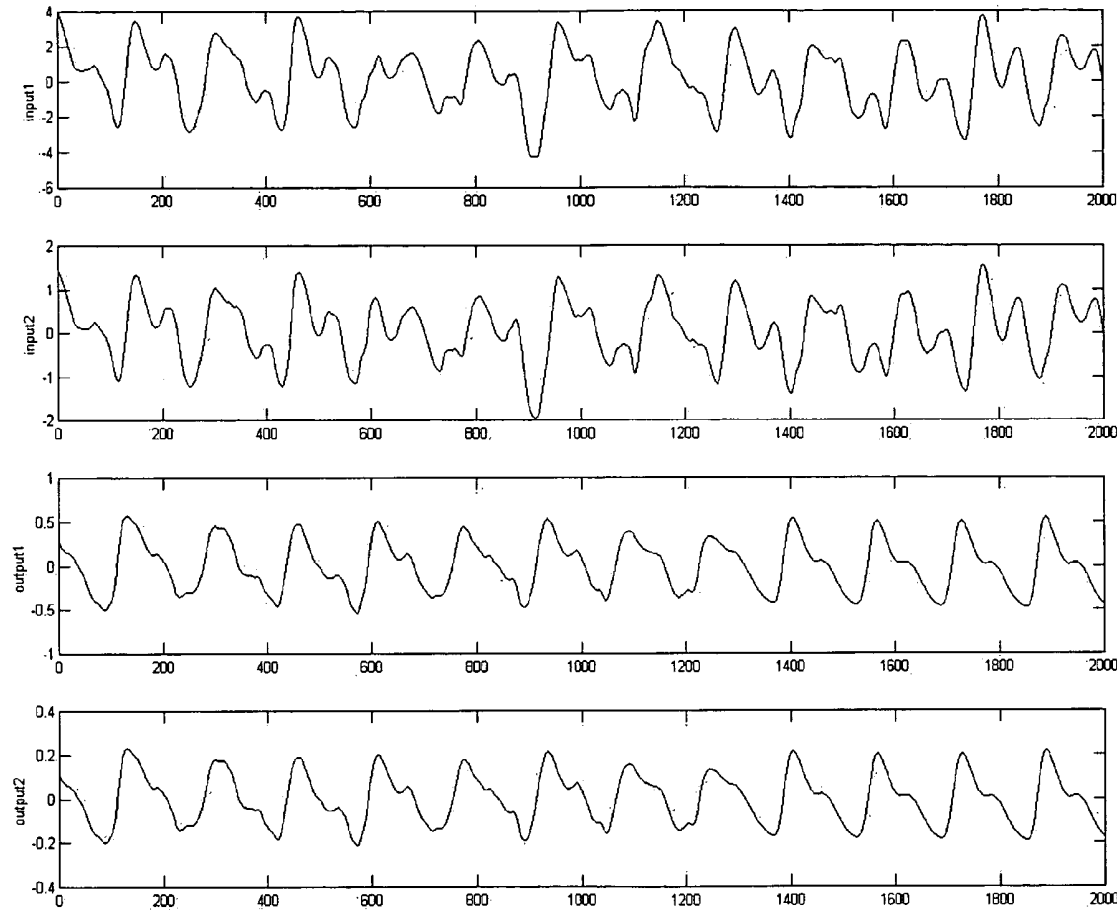

FIG. 8



PHOTOPLETHYSMOGRAPHY (PPG) DEVICE AND THE METHOD THEREOF

BACKGROUND OF THE INVENTION

[0001] The present invention relates to a Photoplethysmography(PPG) device and the method thereof. More particularly, the present technology relates to a pulse oximeter device and the method measuring accurate Photoplethysmography(PPG) signals, reducing the artifacts occurred by the patient motion.

[0002] Photoplethysmography (PPG) is an electro-optic technique to measure the pulse wave of vessels.

[0003] The measuring apparatus for PPG is the pulse oximeter, which considers the relative absorption of Hemoglobin and Oxyhemoglobin to non-invasive measure of arterial oxygen saturation(SpO_2) using the dual-wavelength illumination(LED), and the signal measured by PPG is called photoplethysmographic signal.

[0004] The arterial oxygen saturation (SpO_2) from PPG is a fundamental parameter to diagnose the heart and lung function, the information on the idiosyncrasy in circulating system, the status of heart vessels, and hypoxia, etc. Especially, PPG signal is one of vital signs, basic signal to measure vital parameters of a case, and therefore PPG is used as an important monitoring aid at casual wards and intensive care units.

[0005] The major factors limiting the accuracy and the general applicability in practical pulse oximetry, is low perfusion states or artifact.

[0006] The artifacts added to the oximeter limit the accuracy of measured PPG signals, are mainly occurred by the patient motion and ambient artifact, causing artifact corruption. The ambient artifact is occurred by injected environmental lights.

[0007] The ambient artifact, can be regarded to be less serious, can be appropriately removed through subtraction process, to adopt multiplexing technique against the ambient signals measured independently to restore PPG signal.

[0008] But, the motion artifact, caused by changes in optical probe coupling, patient anatomy, and optical properties of tissue due to geometric realignment, and complex combinations of all these effects, considerably deteriorates the shape of PPG signals and the value of SpO_2 .

[0009] Moreover, the difficulty to reduce motion artifact can be aroused from that PPG and motion artifact signals mostly occupy the frequency band and time domain, same to original signal. Hence, the motion artifact reduction has been regarded as one of important issues to be handled for accurate clinical measurement.

[0010] Some methods have been researched to remove the motion artifact from PPG signals. These methods are the modeling method and three-wavelength method. Typically, the motion artifact detection method identifies the motion artifact from time sequenced PPG signals for efficient artifact concealment; and the modeling method imitates physical process of probe coupling to remove the motion artifact by the inversion of modeled artifact; and three-wavelength method subtracts the motion artifact by use of additional wavelength comparing with dual wavelengths generally

used in PPG device. However, these conventional methods still contains limitation in performance for some specific noise, or limitation in mathematical modeling.

[0011] As further invention is still required to improve the performance of motion artifact rejection without adoption of fake concealment under dual wavelengths constraint, in this invention, the motion artifact reduction method under the constraint of dual wavelengths measurement was newly invented from two simplified observations.

[0012] The signal analysis to reduce motion artifact, basically utilizes independent component analysis(ICA). The basic motivation of ICA is assuming that original PPG signal is from heart pulsation, and motion artifact is another physical factor. Under the assumption, it is clearly possible to model the PPG signal measured with artifact into independent components, original PPG signal and the motion artifact. Based upon the model, the original PPG signal and the motion artifact can be separated through ICA, adopting subtraction technique to minimize the influence of ambient light. But, the practical factors causing motion artifact, also influences on the measured PPG signal, questions are raised in the given assumption, and can be recognized to have difficulties in restoring the original PPG signal by ICA technique.

[0013] Hence, the present invention discloses a new Photoplethysmography(PPG) device and the method therefor, to extract purely original PPG signal reducing motion artifact effectively to enhance the performance of conventional ICA method, combining various preprocessing techniques.

[0014] The present invention also discloses a new processing technique to reduce/eliminate motion artifact in measured PPG signal. For that; before to analyze independent components, from the periodicity of PPG signal, the period of PPG signal is extracted by using auto-correlation function; rearranges signal according to the extracted period by interleaving process; eliminates noise by time low-pass filtering; and increase the independence between PPG signal and motion artifact by innovation processing.

SUMMARY OF THE INVENTION

[0015] The present invention guarantees excellent performance in reducing motion artifact, and more of precise measuring is possible even under the motion artifact.

[0016] The present invention disclosed the method to measure SpO_2 by the newly proposed computing method, adopting mixing matrix in ICA, and the present invention enabled effective separation of signals by; calculating the period using auto-correlation; performing the interleaving over the period; softening the deteriorated signal through low pass filtering; increasing the statistical independence between two components; and fast ICA algorithm. Therefore, the present invention guarantees excellent performance in reducing motion artifact compared to conventional PPG measuring equipment, and more of precise measuring is possible even under the motion artifact.

[0017] The major characteristics of the present invention, is as follows.

[0018] To reduce the artifacts occurred by the patient motion and ambient noise in a pulse oximeter device for accurate Photoplethysmography(PPG) signals, the present

method discloses following steps; a light detecting step to detect dual wavelength illumination from a light detector; A/D conversion step, converting the said detected analog signals into digital ones; preprocessing step reducing noises from the each of outputs from the said A/D conversion step, and to increase independence between the signals; centering process step to subtract the average value from the said outputs of preprocessing step; whitening process step to drive out whitening matrix, by calculating covariance, it's eigen value and eigen matrix from the outputs of the said centering process step; data restoring step to restore data from the output of whitening process setp.

[0019] The present method to measure Photoplethysmography(PPG) signals discloses following steps; a light detecting step to detect dual wavelength illumination from a light detector; A/D conversion step, converting the said detected analog signals into digital ones; preprocessing step reducing noises from the each of outputs from the said A/D conversion step, and to increase independence between the signals; centering process step to subtract the average value from the said outputs of preprocessing step; whitening process step to drive out whitening matrix, by calculating covariance, it's eigen value and eigen matrix from the outputs of the said centering process step; calculating step for the matrix W, to calculate out a demixing matrix W, repeatedly adopting the contrast Gaussian function; calculating step for a mixing matrix A, to calculate out using the outputs from the said whitening process step and the said calculating step for the matrix W; data restoring step to restore data using the said calculating step for the matrix W and the said calculating step for the matrix A.

[0020] The said preprocessing step also discloses following steps in detail; period measuring step to drive out the period of Photoplethysmography(PPG) signals, output from the said A/D conversion step, using autocorrelation; interleaving process step, to relocate data in a given sequence of amplitude according to the said calculated period; time low-pass filtering step to transform over the all sampling points into the average value of current point, previous point, and next point; the innovation process step to subtract the average up to the previous value, from current output of the said time low-pass filtering step.

[0021] The said data restoring step discloses following steps in detail; a step to decide PPG signal between separated PPG signal and noise signal using demixing matrix W, and then restoring the sign and gain of measured PPG signal using the mixing matrix A; calculating step to calculate the ratio R of the normalized transmitted amount of red and infrared lights, from the said matrix A; the step calculating the arterial oxygen saturation (SpO₂), using the said R, by the given formula.

$$\text{arterial oxygen saturation (SpO}_2\text{)(\%)}=a-bR,$$

[0022] (where, $107 \leq a \leq 110$, $25 \leq b \leq 32$)

[0023] The present Photoplethysmography(PPG) measuring device comprises; the light emitting unit composed of two LEDs(light emitting diodes) to emit dual beams of different wavelengths, and a driving circuit for said LEDs; the light detector unit to transform the said transmitted or reflected lights of dual wave lengths, into electrical signals; input separating circuit to amplify the output from the said the light detector unit, and to reduce ambient artifact; A/D

converter unit to convert the output analog signals from the said input separating circuit, into digital signals; digital signal processing unit to reduce motion artifact from the output of the said A/D converter unit; a computer unit to evaluate, store, and display the received output signal from the said digital signal processing unit.

[0024] The communication between the said digital signal processing unit and the said computer unit, to transmit the out put from the said digital signal processing unit to the said computer unit, is performed in wire and/or wireless channel.

DETAILED DESCRIPTION OF THE DRAWINGS

[0025] The above objects and the other features of the present invention will become more apparent by describing in detail preferred embodiments thereof with reference to the attached drawings, in which;

[0026] FIG. 1 is a graph for the normal wavelength distribution of each LED, with absorption coefficient according to the wavelength;

[0027] FIG. 2 is a block diagram of the Photoplethysmography(PPG) device, according to an embodiment of the present invention;

[0028] FIG. 3 is a flow chart to reduce motion artifact using independent component analysis, according to an embodiment of the present invention;

[0029] FIG. 4 is an example of PPG signal interleaved from original signal and measured one with motion artifact;

[0030] FIG. 5 is an example of the result of separated PPG and motion artifact, adopting only conventional independent component analysis(ICA);

[0031] FIG. 6 is an example of the result of separated PPG and motion artifact, adopting principle component analysis(PCA) with preprocessing procedures, according to an embodiment of the present invention;

[0032] FIG. 7 is an example of the result of separated PPG and motion artifact, adopting step up to independent component analysis, according to an embodiment of the present invention;

[0033] FIG. 8 is an example of restored PPG signal from the Photoplethysmography(PPG) device, according to an embodiment of the present invention.

DETAILED DESCRIPTION OF THE INVENTION

[0034] Hereinafter, the present invention on a Photoplethysmography (PPG) device and the method thereof, are described in detail with reference to its theoretical background and the accompanying drawings.

[0035] First of all, the characteristics of PPG signal can be described as follows.

[0036] The mechanism used to measure PPG signal by a pulse oximeter, is that heart pulsation causes changes in absorption coefficients of hemoglobin and oxyhemoglobin in wavelength function. Especially, absorption characteristics of hemoglobin and oxyhemoglobin are changed near the wavelength of red light(660 nm) and near infrared(890 nm) region, it is possible to measure PPG signal using those two lights of different wavelengths.

[0037] FIG. 1 is a graph for the normal wavelength distribution of each LED, with absorption coefficient according to the wavelength, the solid line is for hemoglobin and the dotted line is for oxyhaemoglobin, respectively.

[0038] Also, SpO₂ is given as following formula (1).

$$\text{SpO}_2 (\%) = \frac{[\text{O}_2\text{Hb}]}{[\text{O}_2\text{Hb}] + [\text{Hb}]} \times 100 \quad (1)$$

[0039] SpO₂ means the percentage of oxyhaemoglobin to the total sum of hemoglobin and oxyhemoglobin in blood, in case of normally healthy person, it closes to the value of 100.

[0040] In conventional method, the value of SpO₂ at the practical diagnosis, can be calculated using weighted moving average(WMA) method. This method enables time domain signal processing, within $\pm 2\%$ (± 1 of variance) of error.

[0041] Recently developed algorithm to enhance the measured SpO₂, also uses Fast Fourier Transform(FFT) and Discrete Cosine Transform(DCT). Applying the said algorithm with the sampling rate of 15 Hz and 64 point FFT, SpO₂ can be calculated by the formula (2).

$$\text{SpO}_2 (\%) = 110 - 25 \times R \quad (2)$$

[0042] The R is the normalized ratio between the amount of transmitted red and infrared lights. And also, the R can be expressed as the following formula (3).

$$R = \frac{AC_R / DC_R}{AC_{IR} / DC_{IR}} \quad (3)$$

[0043] AC_R component is signal variation in transmitted red light, and AC_{IR} component is signal variation in transmitted infrared light, followed by heart pulsation. DC_R component is the total average of transmitted red light, and DC_{IR} component is the total average of transmitted infrared light. AC components, AC_R, AC_{IR} are expressed in peak-to-peak value of output signals.

[0044] However, when motion artifact is injected into signal to vary output AC value in a considerable amount, it is impossible to measure SpO₂ precisely.

[0045] Hence, the present invention offers a technique to measure the values R and SpO₂, after restoring original PPG signal through the proposed real-time motion artifact reducing system.

[0046] Next, principle component analysis(PCA) adopted to the present invention will be described.

[0047] The principle component analysis(PCA) is a method widely used in the fields of signal processing, statistics, neural computing, and sometimes called as "Karhunen-Loeve transform"(KLT). The basic concept of the principle component analysis(PCA) is, to find out the concerned components among linearly transformed components of the number n, using the maximum value of possible variance. This is defined as an intuitive method through some repeated calculations.

[0048] In the first step of principle component analysis(PCA), vector x is centered by subtracting its average value (ie. $x \rightarrow x - E\{x\}$). Then, transformed into another vector y with m elements, to decrease overlapping in correlation. This process is to find out circulated orthonormal coordinate system, to let x uncorrelated in the new coordinate system. At the same time, the variance of projected vector x can be maximized on the new coordinate, so the first axis can be laid in the direction of maximum variance, while the second axis is to the perpendicular to the first axis.

[0049] It can be written in the following formula (4), letting w₁ the direction of the first principle component y₁.

$$y_1 = \sum_{k=1}^n w_k x_k = w_1^T x \quad (4)$$

$$w_1 = E\{y_1^2\} = \arg \max_{\|w\|=1} E\{(w^T x)^2\} = w_1^T E\{xx^T\} w_1 = w_1^T C_x w_1$$

[0050] where, w₁₁, . . . , w_{n1} are the weights of nth dimensional vector w₁, and w₁ is of mth dimension same as data vector x. Therefore, the first principle component can be projected toward the maximum projection direction. When k-th principle component is decided, kth component is expressed by the difference in previous value as the formula (5).

$$w_k = \arg \max_{\|w\|=1} E\left\{ \left\| w^T \left(x - \sum_{i=1}^{k-1} w_i w_i^T x \right) \right\|^2 \right\} \quad (5)$$

[0051] The principle component given by $y_i = w_i^T x$, is calculated by covariance matrix $C = E\{xx^T\}$. When order eigenvalue $d_1, \dots, d_n (d_1 \geq d_2 \geq \dots \geq d_n)$, corresponding, to eigenvector per unit length of C, e_1, \dots, e_n , it results in $e_i = w_i$.

[0052] PCA (principle component analysis) is an optimal linear dimension reduction technique, using mean-square. It enables compression to decrease overlapping in x, using cross-correlation between given elements. This dimension reduction technique can have some of important merits. First, it offers convenience in computing, to decrease overhead in a processing stage. Second, it reduces the influence of noise. Third, it is useful to predict data, for to be projected into a subspace of very low dimension. It is important that there is no need to use n of principle components.

[0053] In a subspace, some of other orthonormal basis effects on data compression or noise reduction, in conjunction with principle components.

[0054] The purpose of PCA (principle component analysis) is concerned with the purpose of ICA (independent component analysis).

[0055] But, the property of overlapping can not be emphasized in ICA, when the overlapping is measured by correlation between data components in PCA with increased independence. PCA becomes useful preprocessing step in ICA, for it eliminates cross correlation, and decreases the effect of first and second-order statistics through centering and whitening.

[0056] Next, the ICA process will be explained.

[0057] To define ICA, a statistical "latent variables model" will be utilized. The measured output for n of components is a linear combination of the multiplication of each component and mixing matrix (see formula (6)).

$$x_j = a_{j1}s_1 + a_{j2}s_2 + \dots + a_{jn}s_n, \text{ for all } j \quad (6)$$

[0058] This establishes under the assumption that n of components should be statistically independent with Gaussian distribution, and unknown mixing matrix is in square form. If non-Gaussianity is not guaranteed for inputs, it would cause slow processing time for estimation.

[0059] The mechanism of ICA estimation is based upon Central Limit Theorem, that the distributed sum of independent random variable is more gaussian. Assuming all the components have identical distribution, it can be expressed as formula (7).

$$y = w^T x = \sum_i w_i x_i \text{ (where, } w \text{ is determined vector)} \quad (7)$$

[0060] Then, w is one of columns in inverse matrix of A, and for estimation, z can be newly defined as formula (8).

$$Z = A^T w \rightarrow y = w^T x = w^T A z = z^T S \quad (8)$$

[0061] z^Ts becomes same to the one of s_i, when z^Ts gets more gaussian than any other one of s_i, then the vector w to maximize nongaussianity of w^Tx should be found out. It is known as objective(contrast) function to maximize or minimize some property for estimation.

[0062] Next is the explanation on the Fast ICA algorithm.

[0063] The basic method to maximize contrast function, is the adaptive algorithm based on stochastic gradient descent. It is fast adaptive even under the nonstationary circumstance. But the speed of convergence is relatively slow, and considerably influenced by learning rate selection. Besides, the fixed-point algorithm of recent interest, which is known Fast ICA, has fast convergence speed and unique characteristic, because it calculates large data in one step at a time.

[0064] Another characteristic of fixed point algorithm is to find out directly an independent component with non-Gaussian distribution, using a certain non-linearity function g.

[0065] Hence, the performance of the method can be optimized, by choosing proper g of non-linearity, then each of independent components is estimated one by one as done in the projection pursuit. To pursuit an independent component, firstly the maxima of Negative Entropy(Negentropy) is found from the optima of E {G(w^Tx)}. Under Kuhn-Tucker condition within the range of E(w^Tx)²=|w|²=1, the optima of E{G(w^Tx)} is decided as a point given in formula (9).

$$E \{xg(w^T x)\} - \beta w = 0 \quad (9)$$

[0066] where, $\beta = E \{w_0^T xg(w_0^T x)\}$, and w₀ is the optimum value of w.

[0067] Solving this by Newton's method, it results in a Jacobean matrix JF(w), as shown in formula (10).

$$JF(w) = E \{x x^T g'(w^T x)\} - \beta I \quad (10)$$

[0068] To make inversion of the matrix simple, JF(w) becomes diagonal by approximation of the first term, and approximate Newton iteration can be done by approximating β using present value of w, instead of w₀.

$$w^+ = w - [E \{xg(w^T x)\} - \beta w] [E \{g'(w^T x)\} - \beta]^{-1} \\ w^* = w^+ / \|w^+\| \quad (11)$$

[0069] w* is new value of w, and $\beta = E \{w^T xg(w^T x)\}$.

[0070] Dividing the both side of formula (11) with $\beta - E \{g'(w^T x)\}$ to simplify, it becomes fixed-point algorithm expression (see formula (12)).

$$w^+ = E \{xg(w^T x)\} - E \{g'(w^T x)\} w \\ w^* = w^+ / \|w^+\| \quad (12)$$

[0071] As mentioned above, to pursuit n components by one unit estimation, it should be repeated by n times. By adding orthogonalizing projection into the loop, estimating different independent component is also possible for each time. Projecting present w(k) over orthogonal space formed by the column of mixing matrix B, one each of independent components can be found out at a time. Letting B' the previous value of column in B, it is as given in formula (13).

$$w(k) = w(k) - B' B'^T w(k) \quad (13)$$

[0072] Here, divide w(k) with it's norm.

[0073] This additional projection is performed prior to start iteration and to perform the estimation.

[0074] Next is the explanation on additive algorithm in preprocessing.

[0075] It still has difficulties in perfect restoration, to adopt ICA algorithm to practical data. Hence, the present invention proposes additive algorithm in preprocessing, to overcome the problems arisen from the fact, that measured PPG signal is mainly influenced by noise, and the signal from given dual channels are almost similar.

[0076] The additive algorithm proposed in the present invention contains; period measurement using autocorrelation, interleaving process, time low pass filtering, innovation process.

[0077] Firstly, period measurement using autocorrelation is described in the followings.

[0078] The original PPG signal has periodical characteristics, according to heart pulsation. Even for the periodical characteristics deteriorated by motion artifact, it is possible to extract period data, adopting autocorrelation over a given interval of the signal.

[0079] The auto-correlation $\beta(k)$ of the measured signal is expressed as formula (14):

$$\phi(k) = \lim_{N \rightarrow \infty} \frac{1}{(2N+1)} \sum_{m=-N}^N x(m)x(m+K) \quad (14)$$

[0080] Formula (15) is for a signal with period P.

$$\phi(k) = \phi(k+P) \quad (15)$$

[0081] From this paragraph, the explanation on interleaving process in the present invention is followed. Interleaving process is the method, generally applied to mobile communication, of relocation used to reduce burst error in transmitted bit stream. For example, when 5 of 7 bit Hamming code words were expressed as follows;

$$\text{[0082] } 1234567 \ 1234567 \ 1234567 \ 1234567 \ 1234567$$

[0083] The signal output through interleaver, is as follows.

$$\text{[0084] } 11111 \ 22222 \ 33333 \ 44444 \ 55555 \ 66666 \\ 77777$$

specific algorithm proposed in the present invention. The ICA algorithm of the invention is Fast ICA one.

[0102] FIG. 3 is the flow chart as an example to reduce motion artifact using ICA, comprising; preprocessing step, PCA step, and ICA step. The two channel signals detected by light detector unit 20, is converted into digital data and inputted to digital signal processing(DSP) unit 45 (step S300). Then the period is calculated by computing to average distance among the maximum values in the inputted data (step S310). The example is for selecting 15 of period blocks. In this example, 15 of period blocks were selected however, this number can be chosen into any other numbers. Interleaving process can be performed over the said 15 period blocks, to rearrange in the sequence of magnitude (step S330). Then time low-pass filtering process is performed over the all sampling points to transform each point into the average value of current point, previous point, and next point (step S340). The innovation process step is followed, to subtract the average up to the previous value, from current output of the said time low-pass filtering step (step S350).

[0103] Next centering process is to subtract the average value from the signal output of the said innovation process (step S360). To calculate covariance from the output (step S370), to drive out the eigenvalue D and eigen matrix E of the covariance (step S380), then whitening process is performed using the eigenvalue D and eigen matrix E of the covariance (step S390), by calculating whitening matrix and dewhitening matrix as in the formula (18).

$$\begin{aligned} \text{whiteningMatrix} &= \text{inv}(\text{sqrt}(D)) * E' \\ \text{dewhiteningMatrix} &= E * \text{sqrt}(D) \end{aligned} \quad (18)$$

[0104] Using the said whitening matrix and the original data, a new vector V given in the form of whitening Matrix*original data is generated (step S400). From this, an arbitrary 2x2 matrix W is generated as in the formula (19) (step S410). And apply the result into the nonlinear function w^+ (step S420).

$$w^+ = w - E\{vg(w^T v)\} - E\{g(w^T v)\}w \quad (19)$$

[0105] Then the two channel data, when the matrix w and the nonlinear function w^+ is equal, can be outputted (step S430).

[0106] The whole flow chart of the present invention, according to an example, is in the following sequence.

[0107] First, the period is measured after storing the given number of data. The number of data can be chosen to be 2500.

[0108] Second, the data over 10 time of period, are used and the rest of those are returned. The present example uses the data over 10 time of period however, the number of data used is variable into a certain number.

[0109] Third, the preprocessing is performed, comprising of; interleaving process, time low pass filtering, innovation process.

[0110] Forth, centering process is performed.

[0111] Fifth, after calculating covariance with it's eigenvalue and eigen matrix, whitening is performed.

[0112] Sixth, using the repeating contrast Gaussian function, the demixing matrix W is calculated. When it is

repeated over the maximum repeating times, it is terminated and the result is substituted by the previous output.

[0113] Seventh, using the said fifth and sixth results, mixing matrix A is calculated.

[0114] Eighth, using the said matrix A and W, restore the original signal, compute R, and calculate Sp_{O_2} . At this process, the result of ICA can be outputted.

[0115] This eighth step is to decide PPG signal between separated PPG signal and noise signal using demixing matrix W; and then restoring the sign and gain of measured PPG signal using the mixing matrix A; calculating step to calculate the ratio R of the normalized transmitted amount of red and infrared lights, from the said matrix A; the step calculating the arterial oxygen saturation (Sp_{O_2}), using the said R, by the given formula (21).

[0116] Finally, the process is repeated from the first step, until the end of data.

[0117] FIG. 4 shows a given example of the result from interleaving process upon a measured PPG including motion artifact. FIG. 4(b) is auto-correlation of the measured PPG including motion artifact in FIG. 4(a). It is maximum at the very beginning, and has other maximum values with a regular interval. Therefore, the average of the maximum values over the threshold can be decided as period. Even though the signal is severely deteriorated due to the motion artifact injected over some interval, it can't influence the period measurement, because the data used for auto-correlation are over than 10 periods. FIG. 4(d) is the wave data before adopting time low pass filtering. The signal gets clearer than FIG. 4(c), which is the result of interleaving only, before the filtering. FIG. 4(e) is the result of innovation process for the time low pass filtered output, after restoring the original signal through re-interleaving. The spikes in FIG. 4(e) are interleaving error, and those can be separated as artifact component in ICA.

[0118] Next, the experimental result of the present invention compared to the conventional PPG measuring equipment and method, will be explained. The experiment was performed for the case of bending motion with small vibration in the up-down direction over a fixed wrist, and the case of random motion as artifact, respectively. The results are shown in the FIG. 5 to FIG. 8.

[0119] FIG. 5 is a given example of the result adopting the conventional ICA method only. In the figure, s1 is observed infrared(IR) light signal and s2 is for red light signal, and Sep1 and Sep2 is the separated signals according to wavelengths through ICA.

[0120] As shown in the FIG. 5, motion artifact and original PPG can not be separated clearly by the basic ICA method, on the contrary, it shows to be separated into PPG with artifact (FIG. 5(d)) and small level noise (FIG. 5(c)). These result proves that the original signal and motion artifact can be hardly separated, because of the correlation between the two signals.

[0121] FIG. 6 is an example of result separated through PCA including the preprocessing steps of the present invention. FIG. 6 is the result of PCA including the preprocessing steps of the present invention for the PPG with motion artifact, and s1 is infrared(IR) light signal and s2 is red light signal of given wavelengths, and PCA1 and PCA2 are the results taken through PCA.

[0122] FIG. 6(a) is for bending motion, and shows smoothed motion artifact. FIG. 6(b) is the case of random motion for 3 seconds as artifact, and shows PCA output is restored almost without deterioration.

[0123] FIG. 7 is a given example of the invention, the result processed to ICA, that is processed through preprocessing, PCA, and ICA. In FIG. 7, input1 is the observed infrared(IR) light signal, input2 is the observed red light signal, sep1 is original signal, and sep3 is separated noise signal. The waveform in FIG. 7 was taken through; preprocessing step comprising period measuring, time low pass filtering, innovation process; PCA; then primary components were separated one by one through repeated Gaussian nonlinear function. It shows that the signal level gets constant to a certain level, and the input is separated into PPG and motion artifact when input has no saturation.

[0124] But, looking over the separated signals through ICA as in FIG. 7, the waveform is restored only, while the gain and sign are not. As long as, PPG is an important factor not only to calculate the shape of AC component, but also to compute SpO₂, the present invention proposes a formula to compute SpO₂ using ICA.

[0125] In ICA model, the observed two variables can be expressed as in the formula (20).

$$\begin{bmatrix} x_1 \\ x_2 \end{bmatrix} = \begin{bmatrix} a_1 & a_2 \\ b_1 & b_2 \end{bmatrix} \begin{bmatrix} s_1 \\ s_2 \end{bmatrix} \quad (20)$$

[0126] When, letting X be the output with motion artifact, s₁ becomes original PPG, and S₂ can be assumed to be motion artifact. Without motion, S₂ is separated as random noise. Then a₁ contains the information of original signal for IR wavelength, a₂ becomes motion information over IR measurement. In the same way, b₁ contains the information of original signal for red light wavelength, and b₂ becomes motion information over red light measurement. Therefore, the value of R in the present invention establishes R=b₁/a₁. As for this value, only the AC part for gain control without the influence of DC component, was considered, the result is in a little bit decreased value. By the repeating experiment for the conventional formula to calculate SpO₂, the formula (2) (SpO₂(%)=110-25×R), the value of R is 0.48~0.56 for normal person within the 96%~98% SpO₂.

[0127] Meanwhile, the value of R computed in the present invention is within the range of 0.35~0.45, and the first term of the formula (2) can be approximated as formula (21) in accordance to 96~98(%) of SpO₂ value. In the formula (21), varying the gradient of b makes b=(0.45-0.35)/(0.56-0.48)=1.25, then 25×b=32. For a, the relation a=25×(0.48-0.35) results 110-a=107. Hence, the new formula for computing SpO₂ is approximated as formula (21).

$$\text{SpO}_2(\%)=a-bR \quad (21)$$

[0128] (where, 107 ≤ a ≤ 110, 25 ≤ b ≤ 32)

[0129] An example of formula (21) to compute SpO₂ is the formula (22).

$$\text{SpO}_2(\%)=107-25 \times R \text{ or } =110-32 \times R \quad (22)$$

[0130] In the formula (20), the information to be known additionally is that which one is the original PPG between s₁

and S₂. As long as the characteristics of ICA restores the shape of signal only, rather than the gain and sign, the separated signal of the first channel can be both of original signal and motion artifact.

[0131] This problem of indefiniteness is solved in the present invention, adopting demixing matrix W, given as S=WX. W can be generated from eigen vector and singular value decomposition, and can be taken through repeating projection and nonlinearity. So the matrix w means the importance of the information. Therefore, by comparing W[1][1] and W[2][1] to output larger value, the original signal can be decided.

[0132] In conclusion, when x₁=a₁×s₁+a₂×s₂, s₁ becomes original PPG and s₂ is motion artifact. Then a₂ can be substituted into zero, then x₁=a₁×s₁, x₂=b₁×s₁ established, so the signal can be restored.

[0133] FIG. 8 shows an example of the result measured by the SpO₂ measuring device of the present invention.

[0134] In the present invention, the original PPG was restored by separating the PPG and motion artifact signal from the motion added signal, by additive preprocessing step to the basic ICA algorithm. And the present invention adopted a new computational method to measure SpO₂ adopting mixing matrix into ICA.

[0135] Furthermore, the present invention enabled effective separation of signals by; calculating the period using auto-correlation; performing the interleaving over the period; softening the deteriorated signal through time low pass filtering; increasing the statistical independence between two components; and fast ICA algorithm.

[0136] The present invention guarantees excellent performance in reducing motion artifact compared to conventional PPG measuring equipment, and more of precise measuring is possible even under the motion artifact.

[0137] In addition, the present invention has effect to reduce motion artifact, added to PPG while the measurement performed upon the case in walking. And make it easier for the senior people to measure PPG at home, or in the field of sports medical science, the condition of the athletes can be easily and precisely measured.

[0138] In here, although the preferred embodiments of the present invention have been described, it will be understood by those skilled in the art that the present invention should not be limited to the described preferred embodiments, but various changes and modifications can be made within the spirit and scope of the present invention as defined by the appended claims.

What is claimed is:

1. The method to measure Photoplethysmography(PPG) signals comprising the steps wherein;

- (a) a light detecting step to detect dual wavelength illumination from a light detector;
- (b) A/D conversion step, converting the said detected analog signals into digital ones;
- (c) preprocessing step reducing noises from the each of outputs from the said A/D conversion step, and to increase independence between the signals;

- (d) centering process step to subtract the average value from the said outputs of preprocessing step;
 - (e) whitening process step to drive out whitening matrix, by calculating covariance, it's eigen value and eigen matrix from the outputs of the said centering process step;
 - (f) data restoring step to restore data from the output of whitening process setp.
2. The method to measure Photoplethysmography(PPG) signals comprising the steps wherein;

- (a) light detecting step to detect dual wavelength illumination from a light detector;
- (b) A/D conversion step, converting the said detected analog signals into digital ones;
- (c) preprocessing step reducing noises from the each of outputs from the said A/D conversion step, and to increase independence between the signals;
- (d) centering process step to subtract the average value from the said outputs of preprocessing step;
- (e) whitening process step to drive out whitening matrix, by calculating covariance, it's eigen value and eigen matrix from the outputs of the said centering process step;
- (f) calculating step for the matrix W, to calculate out a demixing matrix W, repeatedly adopting the contrast Gaussian function;
- (g) calculating step for a mixing matrix A, to calculate out using the outputs from the said whitening process step and the said calculating step for the matrix W;
- (h) data restoring step to restore data using the said calculating step for the matrix W and the said calculating step for the matrix A.

3. The method as claimed in claim 1 or claim 2, wherein the preprocessing step includes steps of;

- (a) period measuring step to drive out the period of Photoplethysmography(PPG) signals, from the output of the said A/D conversion step, using autocorrelation;
- (b) interleaving process step, to relocate data in a given sequence of amplitude according to the said calculated period;
- (c) time low-pass filtering step to transform over the all sampling points into the average value of current point, previous point, and next point;
- (d) the innovation process step to subtract the average up to the previous value, from current output of the said time low-pass filtering step.

4. The method as claimed in claim 2, wherein the data restoring step includes steps of;

- (a) step to decide Photoplethysmography(PPG) signal between separated Photoplethysmography(PPG) signal and noise signal using demixing matrix W, and then restore the sign and gain of measured Photoplethysmography(PPG) signal using the mixing matrix A;
- (b) calculating step to calculate the ratio R of the normalized transmitted amount of red and infrared lights, from the said matrix A;
- (c) the step calculating the arterial oxygen saturation (SpO_2), using the said R, by the given formula.

$$\text{arterial oxygen saturation } (SpO_2)(\%)=a-bR,$$

(where, $107 \leq a \leq 110$, $25 \leq b \leq 32$)

5. The Photoplethysmography(PPG) measuring device comprising the elements of;

- (a) light emitting unit composed of two LEDs(light emitting diodes) to emit dual beams of different wavelengths, and a driving circuit for said LEDs;
- (b) light detector unit to transform the said transmitted or reflected lights of dual wave lengths, into electrical signals;
- (c) input separating circuit to amplify the output from the said the light detector unit, and to reduce ambient artifact;
- (d) A/D converter unit to convert the output analog signals from the said input separating circuit, into digital signals;
- (e) digital signal processing unit to reduce motion artifact from the output of the said A/D converter unit;
- (f) computer unit to evaluate, store, and display the received output signal from the said digital signal processing unit.

6. The device as claimed in claim 5;

the communication between the said digital signal processing unit and the said computer unit, to transmit the output from the said digital signal processing unit to the said computer unit, is performed through wireless channel.

7. The device as claimed in claim 5;

the communication between the said digital signal processing unit and the said computer unit, to transmit the output from the said digital signal processing unit to the said computer unit, is performed through wire channel.

* * * * *

专利名称(译)	光电容积脉搏波 (PPG) 装置及其方法		
公开(公告)号	US20050058456A1	公开(公告)日	2005-03-17
申请号	US10/884957	申请日	2004-07-07
[标]申请(专利权)人(译)	裕善KOOK		
申请(专利权)人(译)	裕善KOOK		
当前申请(专利权)人(译)	硅MITUS INC.		
[标]发明人	YOO SUN KOOK		
发明人	YOO, SUN KOOK		
IPC分类号	A61B5/02 A61B5/00 H04B10/00		
CPC分类号	A61B5/7207 A61B5/14551		
优先权	1020030045673 2003-07-07 KR		
其他公开文献	US7336982		
外部链接	Espacenet USPTO		

摘要(译)

测量光电容积脉搏波 (PPG) 信号的方法可以包括检测来自光检测器的双波长照射, 以便提供检测信号, 将检测到的信号转换成数字信号, 以便提供数字信号, 减少来自数字信号的噪声并增加之间的独立性。数字信号, 以提供预处理信号, 从预处理信号中减去平均值, 以提供调整后的信号, 获得基于协方差的白化矩阵, 特征值和从调整后的信号中获得的特征矩阵, 并使用白化恢复数据矩阵。

