



US008874181B2

(12) **United States Patent**
Petersen et al.

(10) **Patent No.:** **US 8,874,181 B2**
(45) **Date of Patent:** **Oct. 28, 2014**

(54) **OXIMETER AMBIENT LIGHT CANCELLATION**

(58) **Field of Classification Search**

USPC 600/310, 322, 323, 336
See application file for complete search history.

(71) Applicant: **Covidien LP**, Boulder, CO (US)

(72) Inventors: **Ethan Petersen**, Castro Valley, CA (US);
William Shea, Livermore, CA (US);
Bradford B. Chew, San Ramon, CA (US)

(56) **References Cited**

U.S. PATENT DOCUMENTS

3,638,640 A 2/1972 Shaw
4,714,341 A 12/1987 Hamaguri et al.

(Continued)

FOREIGN PATENT DOCUMENTS

DE 19647877 5/1998
EP 194105 5/1991

(Continued)

OTHER PUBLICATIONS

U.S. Appl. No. 12/172,981, filed Jul. 14, 2008, Petersen.

(Continued)

(73) Assignee: **Covidien LP**, Mansfield, MA (US)

(*) Notice: Subject to any disclaimer, the term of this patent is extended or adjusted under 35 U.S.C. 154(b) by 0 days.

(21) Appl. No.: **13/663,244**

(22) Filed: **Oct. 29, 2012**

(65) **Prior Publication Data**

US 2013/0123593 A1 May 16, 2013

Related U.S. Application Data

(60) Continuation of application No. 12/172,981, filed on Jul. 14, 2008, now Pat. No. 8,315,684, which is a continuation of application No. 11/495,415, filed on Jul. 28, 2006, now Pat. No. 7,400,919, which is a division of application No. 10/787,854, filed on Feb. 25, 2004, now Pat. No. 7,190,985.

(51) **Int. Cl.**

A61B 5/1455 (2006.01)
A61B 5/0205 (2006.01)
A61B 5/00 (2006.01)
A61B 5/024 (2006.01)

(52) **U.S. Cl.**

CPC **A61B 5/14552** (2013.01); **A61B 5/0205** (2013.01); **A61B 5/14551** (2013.01); **A61B 5/7278** (2013.01); **A61B 5/725** (2013.01); **A61B 5/7203** (2013.01); **A61B 5/7228** (2013.01); **A61B 5/02416** (2013.01); **A61B 5/7225** (2013.01)

USPC **600/336**; **600/322**

Primary Examiner — Eric Winakur

(74) *Attorney, Agent, or Firm* — Fletcher Yoder PC

(57) **ABSTRACT**

A pulse oximeter method and apparatus which provides (1) a notch filter at a distance between a modulation frequency and a common multiple of commonly used power line frequencies (50, 60, 100 and 120) and also (2) a demodulation frequency greater than a highest pulse rate of a person and lower than any harmonic of 50, 60, 100 or 120 Hz, to filter ambient light interference, while choosing an optimum demodulation frequency that avoids interference from the notch filter or from harmonics of the line interference. Also, ambient light for any low frequency interference, such as power line interference, is measured both before and after each of the light emitter wavelengths and the average of the ambient light is then subtracted from the detected signal.

19 Claims, 3 Drawing Sheets

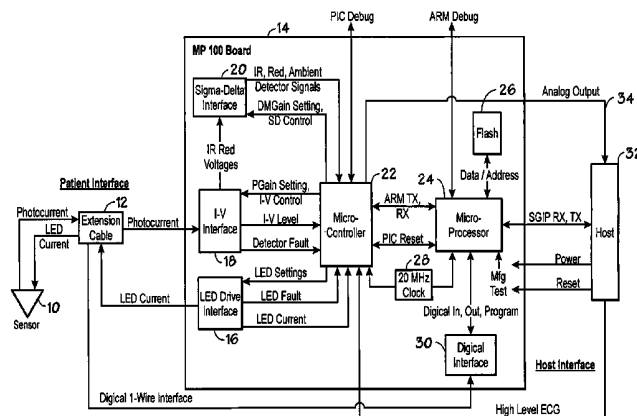

(56)

References Cited

U.S. PATENT DOCUMENTS

4,781,195 A	11/1988	Martin	5,919,134 A	7/1999	Diab
4,800,885 A	1/1989	Johnson	5,920,263 A	7/1999	Huttenhoff et al.
4,802,486 A	2/1989	Goodman et al.	5,921,921 A	7/1999	Potratz et al.
4,805,623 A	2/1989	Jöbbsis	5,924,979 A	7/1999	Swedlow et al.
4,807,630 A	2/1989	Malinouskas	5,954,644 A	9/1999	Dettling et al.
4,807,631 A	2/1989	Hersh et al.	5,995,855 A	11/1999	Kiani et al.
4,848,901 A	7/1989	Hood, Jr.	5,995,856 A	11/1999	Mannheimer et al.
4,863,265 A	9/1989	Flower et al.	5,995,859 A	11/1999	Takahashi
4,911,167 A	3/1990	Corenman et al.	6,011,985 A	1/2000	Athan et al.
4,913,150 A	4/1990	Cheung et al.	6,011,986 A	1/2000	Diab et al.
4,928,692 A	5/1990	Goodman et al.	6,064,898 A	5/2000	Aldrich
4,934,372 A	6/1990	Corenman et al.	6,081,742 A	6/2000	Amano et al.
4,936,679 A	6/1990	Mersch	6,088,607 A	7/2000	Diab et al.
4,938,218 A	7/1990	Goodman et al.	6,120,460 A	9/2000	Abreu
4,948,248 A	8/1990	Lehman	6,150,951 A	11/2000	Olejniczak
4,971,062 A	11/1990	Hasebe et al.	6,154,667 A	11/2000	Miura et al.
4,972,331 A	11/1990	Chance	6,163,715 A	12/2000	Larsen et al.
4,974,591 A	12/1990	Awazu et al.	6,181,958 B1	1/2001	Steuer et al.
5,028,787 A	7/1991	Rosenthal et al.	6,181,959 B1	1/2001	Schöllermann et al.
5,065,749 A	11/1991	Hasebe et al.	6,226,539 B1	5/2001	Potratz
5,084,327 A	1/1992	Stengel	6,229,856 B1	5/2001	Diab et al.
5,119,815 A	6/1992	Chance	6,230,035 B1	5/2001	Aoyagi et al.
5,122,974 A	6/1992	Chance	6,266,546 B1	7/2001	Steuer et al.
5,167,230 A	12/1992	Chance	6,285,895 B1	9/2001	Ristolainen et al.
5,190,038 A	3/1993	Polson et al.	6,312,393 B1	11/2001	Abreu
5,246,003 A	9/1993	DeLonzor	6,353,750 B1	3/2002	Kimura et al.
5,247,931 A	9/1993	Norwood	6,385,471 B1	5/2002	Mortz
5,263,244 A	11/1993	Centa et al.	6,397,091 B2	5/2002	Diab et al.
5,275,159 A	1/1994	Griebel	6,397,092 B1	5/2002	Norris et al.
5,279,295 A	1/1994	Martens et al.	6,415,236 B2	7/2002	Kobayashi et al.
5,297,548 A	3/1994	Pologe	6,419,671 B1	7/2002	Lemberg
5,348,004 A	9/1994	Hollub	6,438,399 B1	8/2002	Kurth
5,349,952 A	9/1994	Mccarthy et al.	6,449,501 B1	9/2002	Reuss
5,351,685 A	10/1994	Potratz	6,461,305 B1	10/2002	Schnall
5,355,880 A	10/1994	Thomas et al.	6,466,809 B1	10/2002	Riley
5,368,026 A	11/1994	Swedlow et al.	6,487,439 B1	11/2002	Skladnev et al.
5,368,224 A	11/1994	Richardson et al.	6,496,711 B1	12/2002	Athan et al.
5,372,136 A	12/1994	Steuer et al.	6,501,974 B2	12/2002	Huiku
5,385,143 A	1/1995	Aoyagi	6,501,975 B2	12/2002	Diab et al.
5,390,670 A	2/1995	Centa et al.	6,505,133 B1	1/2003	Hanna et al.
5,413,099 A	5/1995	Schmidt et al.	6,526,301 B2	2/2003	Larsen et al.
5,469,845 A	11/1995	DeLonzor et al.	6,544,193 B2	4/2003	Abreu
5,482,036 A	1/1996	Diab et al.	6,546,267 B1	4/2003	Sugiura et al.
5,483,646 A	1/1996	Uchikoga	6,549,795 B1	4/2003	Chance
5,533,507 A	7/1996	Potratz	6,580,086 B1	6/2003	Schulz et al.
5,553,614 A	9/1996	Chance	6,584,336 B1 *	6/2003	Ali et al. 600/323
5,555,882 A	9/1996	Richardson et al.	6,591,122 B2	7/2003	Schmitt
5,564,417 A	10/1996	Chance	6,594,513 B1	7/2003	Jobsis et al.
5,575,284 A	11/1996	Athan et al.	6,596,016 B1	7/2003	Vreman et al.
5,575,285 A	11/1996	Takanashi et al.	6,606,509 B2	8/2003	Schmitt
5,577,500 A	11/1996	Potratz	6,606,511 B1	8/2003	Ali et al.
5,611,337 A	3/1997	Bukta	6,615,064 B1	9/2003	Aldrich
5,630,413 A	5/1997	Thomas et al.	6,618,042 B1	9/2003	Powell
5,645,059 A	7/1997	Fein et al.	6,622,095 B2	9/2003	Kobayashi et al.
5,645,060 A	7/1997	Yorkey	6,643,530 B2	11/2003	Diab et al.
5,662,106 A	9/1997	Swedlow et al.	6,654,621 B2	11/2003	Palatnik et al.
5,676,141 A	10/1997	Hollub	6,654,624 B2	11/2003	Diab et al.
5,680,857 A	10/1997	Pelikan et al.	6,658,276 B2	12/2003	Kian et al.
5,692,503 A	12/1997	Keunstner	6,658,277 B2	12/2003	Wasserman
5,713,355 A	2/1998	Richardson et al.	6,662,030 B2	12/2003	Khalil et al.
5,730,124 A	3/1998	Yamauchi	6,668,183 B2	12/2003	Hicks et al.
5,746,697 A	5/1998	Swedlow et al.	6,671,526 B1	12/2003	Aoyagi et al.
5,758,644 A	6/1998	Diab et al.	6,671,528 B2	12/2003	Steuer et al.
5,779,631 A	7/1998	Chance	6,678,543 B2	1/2004	Diab et al.
5,782,757 A	7/1998	Diab et al.	6,684,090 B2	1/2004	Ali et al.
5,786,592 A	7/1998	Hök	6,690,958 B1	2/2004	Walker et al.
5,803,910 A	9/1998	Potratz	6,697,658 B2	2/2004	Al-Ali
5,830,136 A	11/1998	DeLonzor et al.	6,708,048 B1	3/2004	Chance
5,830,139 A	11/1998	Abreu	6,708,049 B1 *	3/2004	Berson et al. 600/323
5,831,598 A	11/1998	Kauffert et al.	6,711,424 B1	3/2004	Fine et al.
5,842,981 A	12/1998	Larsen et al.	6,711,425 B1	3/2004	Reuss
5,846,190 A	12/1998	Woehrle	6,731,274 B2	5/2004	Powell
5,871,442 A	2/1999	Madarasz et al.	6,748,253 B2	6/2004	Norris et al.
5,873,821 A	2/1999	Chance et al.	6,778,923 B2	8/2004	Norris et al.
5,885,213 A	3/1999	Richardson et al.	6,785,568 B2	8/2004	Chance
			6,793,654 B2	9/2004	Lemberg
			6,801,797 B2	10/2004	Mannheimer et al.
			6,801,798 B2	10/2004	Geddes et al.
			6,801,799 B2	10/2004	Mendelson

(56)

References Cited

U.S. PATENT DOCUMENTS

6,829,496 B2 12/2004 Nagai et al.
 6,850,053 B2 2/2005 Daalmans et al.
 6,863,652 B2 3/2005 Huang et al.
 6,873,865 B2 3/2005 Steuer et al.
 6,889,153 B2 5/2005 Dietiker
 6,898,451 B2 5/2005 Wuori
 6,930,608 B2 8/2005 Grajales et al.
 6,939,307 B1 9/2005 Dunlop
 6,947,780 B2 9/2005 Scharf
 6,949,081 B1 9/2005 Chance
 6,961,598 B2 11/2005 Diab
 6,983,178 B2 1/2006 Fine et al.
 6,993,371 B2 1/2006 Kiani et al.
 6,996,427 B2 2/2006 Ali et al.
 7,003,339 B2 2/2006 Diab et al.
 7,024,235 B2 4/2006 Melker et al.
 7,027,849 B2 4/2006 Al-Ali
 7,030,749 B2 4/2006 Al-Ali
 7,035,697 B1 4/2006 Brown
 7,047,054 B2 5/2006 Benni
 7,047,056 B2 5/2006 Hannula et al.
 7,062,307 B2 6/2006 Norris et al.
 7,127,278 B2 10/2006 Melker et al.
 7,162,306 B2 1/2007 Caby et al.
 7,190,985 B2 3/2007 Petersen et al.
 7,209,775 B2 4/2007 Bae et al.
 7,221,971 B2 5/2007 Diab et al.
 7,236,811 B2 6/2007 Schmitt
 7,263,395 B2 8/2007 Chan et al.
 7,272,426 B2 9/2007 Schmid
 7,302,284 B2 11/2007 Baker, Jr. et al.
 7,313,427 B2 12/2007 Benni
 7,315,753 B2 1/2008 Baker, Jr. et al.
 7,336,983 B2 2/2008 Baker, Jr. et al.
 7,373,193 B2 5/2008 Al-Ali et al.
 7,400,919 B2 7/2008 Petersen et al.
 7,500,950 B2 3/2009 Al-Ali
 2001/0002206 A1 5/2001 Diab et al.
 2001/0005773 A1 6/2001 Larsen et al.
 2001/0020122 A1 9/2001 Steuer et al.
 2001/0039376 A1 11/2001 Steuer et al.
 2001/0044700 A1 11/2001 Kobayashi et al.
 2002/0026106 A1 2/2002 Khalil et al.
 2002/0035318 A1 3/2002 Mannheimer et al.
 2002/0038079 A1 3/2002 Steuer et al.
 2002/0042558 A1 4/2002 Mendelson
 2002/0049389 A1 4/2002 Abreu
 2002/0062071 A1 5/2002 Diab et al.
 2002/0068859 A1 6/2002 Knopp
 2002/0111748 A1 8/2002 Kobayashi et al.
 2002/0128544 A1 9/2002 Diab et al.
 2002/0133068 A1 9/2002 Huiku
 2002/0156354 A1 10/2002 Larson
 2002/0161287 A1 10/2002 Schmitt
 2002/0161290 A1 10/2002 Chance
 2002/0165439 A1 11/2002 Schmitt
 2002/0198443 A1 12/2002 Ting
 2003/0023140 A1 1/2003 Chance
 2003/0028357 A1 2/2003 Noris et al.
 2003/0055324 A1 3/2003 Wasserman
 2003/0060693 A1 3/2003 Monfre et al.
 2003/0139687 A1 7/2003 Abreu
 2003/0144584 A1 7/2003 Mendelson
 2003/0220548 A1 11/2003 Schmitt
 2003/0220576 A1 11/2003 Diab
 2004/0010188 A1 1/2004 Wasserman
 2004/0054270 A1 3/2004 Pawzner et al.
 2004/0087846 A1 5/2004 Wasserman
 2004/0107065 A1 6/2004 Al-Ali
 2004/0127779 A1 7/2004 Steuer et al.
 2004/0152965 A1 8/2004 Diab et al.
 2004/0171920 A1 9/2004 Mannheimer et al.
 2004/0176670 A1 9/2004 Takamura et al.
 2004/0176671 A1 9/2004 Fine et al.
 2004/0230106 A1 11/2004 Schmitt et al.

2005/0020894 A1 1/2005 Norris et al.
 2005/0075548 A1 4/2005 Al-Ali et al.
 2005/0080323 A1 4/2005 Kato
 2005/0101850 A1 5/2005 Parker
 2005/0113651 A1 5/2005 Wood et al.
 2005/0113656 A1 5/2005 Chance
 2005/0143634 A1 6/2005 Baker, Jr. et al.
 2005/0168722 A1 8/2005 Forstner et al.
 2005/0177034 A1 8/2005 Beaumont
 2005/0192488 A1 9/2005 Bryenton et al.
 2005/0203357 A1 9/2005 Debreczeny et al.
 2005/0228248 A1 10/2005 Dietiker
 2005/0267346 A1 12/2005 Faber et al.
 2005/0283059 A1 12/2005 Iyer et al.
 2006/0009688 A1 1/2006 Lamego et al.
 2006/0015021 A1 1/2006 Cheng
 2006/0020181 A1 1/2006 Schmitt
 2006/0030763 A1 2/2006 Mannheimer et al.
 2006/0052680 A1 3/2006 Diab
 2006/0058683 A1 3/2006 Chance
 2006/0064024 A1 3/2006 Schnall
 2006/0195028 A1 8/2006 Hannula et al.
 2006/0224058 A1 10/2006 Mannheimer
 2006/0247501 A1 11/2006 Ali
 2006/0258921 A1 11/2006 Addison et al.
 2007/0225582 A1 9/2007 Diab et al.
 2008/0017800 A1 1/2008 Benni
 2008/0033265 A1 2/2008 Diab et al.

FOREIGN PATENT DOCUMENTS

EP 1491135 12/2004
 JP 3170866 7/1991
 JP 3238813 10/1991
 JP 7124138 5/1995
 JP 7136150 5/1995
 JP 3116255 12/2000
 JP 2002224088 8/2002
 JP 2003153881 5/2003
 JP 2003153882 5/2003
 JP 2003194714 7/2003
 JP 2003210438 7/2003
 JP 2004008572 1/2004
 JP 2004113353 4/2004
 JP 2004194908 7/2004
 JP 2004248819 9/2004
 JP 2004261364 9/2004
 JP 2004290545 10/2004
 JP 2004329928 11/2004
 WO WO9101678 2/1991
 WO WO9309711 5/1993
 WO WO9843071 10/1998
 WO WO9932030 7/1999
 WO WO0021438 4/2000
 WO WO2005009221 2/2005

OTHER PUBLICATIONS

U.S. Appl. No. 11/495,415, filed Jul. 28, 2006, Petersen.
 U.S. Appl. No. 10/787,854, filed Feb. 25, 2004, Petersen.
 Leahy, Martin J., et al.; "Sensor Validation in Biomedical Applications," *IFAC Modelling and Control in Biomedical Systems*, Warwick, UK; pp. 221-226 (1997).
 Barreto, Armando B., et al.; "Adaptive LMS Delay Measurement in dual Blood Volume Pulse Signals for Non-Invasive Monitoring," *IEEE*, pp. 117-120 (1997).
 East, Christine E., et al.; "Fetal Oxygen Saturation and Uterine Contractions During Labor," *American Journal of Perinatology*, vol. 15, No. 6, pp. 345-349 (Jun. 1998).
 Edrich, Thomas, et al.; "Can the Blood Content of the Tissues be Determined Optically During Pulse Oximetry Without Knowledge of the Oxygen Saturation?—An In-Vitro Investigation," *Proceedings of the 20th Annual International conference of the IEEE Engie in Medicine and Biology Society*, vol. 20, No. 6, p. 3072-3075, 1998.
 Such, Hans Olaf; "Optoelectronic Non-invasive Vascular Diagnostics Using multiple Wavelength and Imaging Approach," *Dissertation*, (1998).

(56)

References Cited

OTHER PUBLICATIONS

Todd, Bryan, et al.; "The Identification of Peaks in Physiological Signals," *Computers and Biomedical Research*, vol. 32, pp. 322-335 (1999).

Goldman, Julian M.; "Masimo Signal Extraction Pulse Oximetry," *Journal of Clinical Monitoring and Computing*, vol. 16, pp. 475-483 (2000).

Coetzee, Frans M.; "Noise-Resistant Pulse Oximetry Using a Synthetic Reference Signal," *IEEE Transactions on Biomedical Engineering*, vol. 47, No. 8, Aug. 2000, pp. 1018-1026.

Kaestle, S.; "Determining Artefact Sensitivity of New Pulse Oximeters in Laboratory Using Signals Obtained from Patient," *Biomedizinische Technik*, vol. 45 (2000).

Belal, Suliman Yousef, et al.; "A fuzzy system for detecting distorted plethysmogram pulses in neonates and paediatric patients," *Physiol. Meas.*, vol. 22, pp. 397-412 (2001).

Chan, K.W., et al.; "17.3: Adaptive Reduction of Motion Artifact from Photoplethysmographic Recordings using a Variable Step-Size LMS Filter," *IEEE*, pp. 1343-1346 (2002).

Cyrril, D., et al.; "Adaptive Comb Filter for Quasi-Periodic Physiologic Signals," *Proceedings of the 25th Annual International Conference of the IEEE EMBS*, Cancun, Mexico, Sep. 17-21, 2003; pp. 2439-2442.

Stetson, Paul F.; "Determining Heart Rate from Noisy Pulse Oximeter Signals Using Fuzzy Logic," *The IEEE International Conference on Fuzzy Systems*, St. Louis, Missouri, May 25-28, 2003; pp. 1053-1058.

Lee, C.M., et al.; "Reduction of motion artifacts from photoplethysmographic recordings using wavelet denoising

approach," *IEEE EMBS Asian-Pacific Conference on Biomedical Engineering*, Oct. 20-22, 2003; pp. 194-195.

A. Johansson; "Neural network for photoplethysmographic respiratory rate monitoring," *Medical & Biological Engineering & Computing*, vol. 41, pp. 242-248 (2003).

Addison, Paul S., et al.; "A novel time-frequency-based 3D Lissajous figure method and its application to the determination of oxygen saturation from the photoplethysmogram," *Institute of Physics Publishing, Meas. Sci. Technol.*, vol. 15, pp. L15-L18 (2004).

J. Huang, et al.; "Low Power Motion Tolerant Pulse Oximetry," *Abstracts*, A7, p. S103. (undated).

Hamilton, Patrick S., et al.; "Effect of Adaptive Motion-Artifact Reduction on QRS Detection," *Biomedical Instrumentation & Technology*, pp. 197-202 (undated).

Odagiri, Y.; "Pulse Wave Measuring Device," *Micromechatronics*, vol. 42, No. 3, pp. 6-11(undated) (Article in Japanese—contains English summary of article).

Cysewska-Sobusaik, Anna; "Metrological Problems With noninvasive Transillumination of Living Tissues," *Proceedings of SPIE*, vol. 4515, pp. 15-24 (2001).

Maletras, Francois-Xavier, et al.; "Construction and calibration of a new design of Fiber Optic Respiratory Plethysmograph (FORP)," *Optomechanical Design and Engineering, Proceedings of SPIE*, vol. 4444, pp. 285-293 (2001).

Relente, A.R., et al.; "Characterization and Adaptive Filtering of Motion Artifacts in Pulse Oximetry using Accelerometers," *Proceedings of the Second joint EMBS/BMES Conference*, Houston, Texas, Oct. 23-26, 2002; pp. 1769-1770.

R. Neumann, et al.; "Fourier Artifact suppression Technology Provides Reliable SpO₂," *Abstracts*, A11, p. S105. (undated).

* cited by examiner

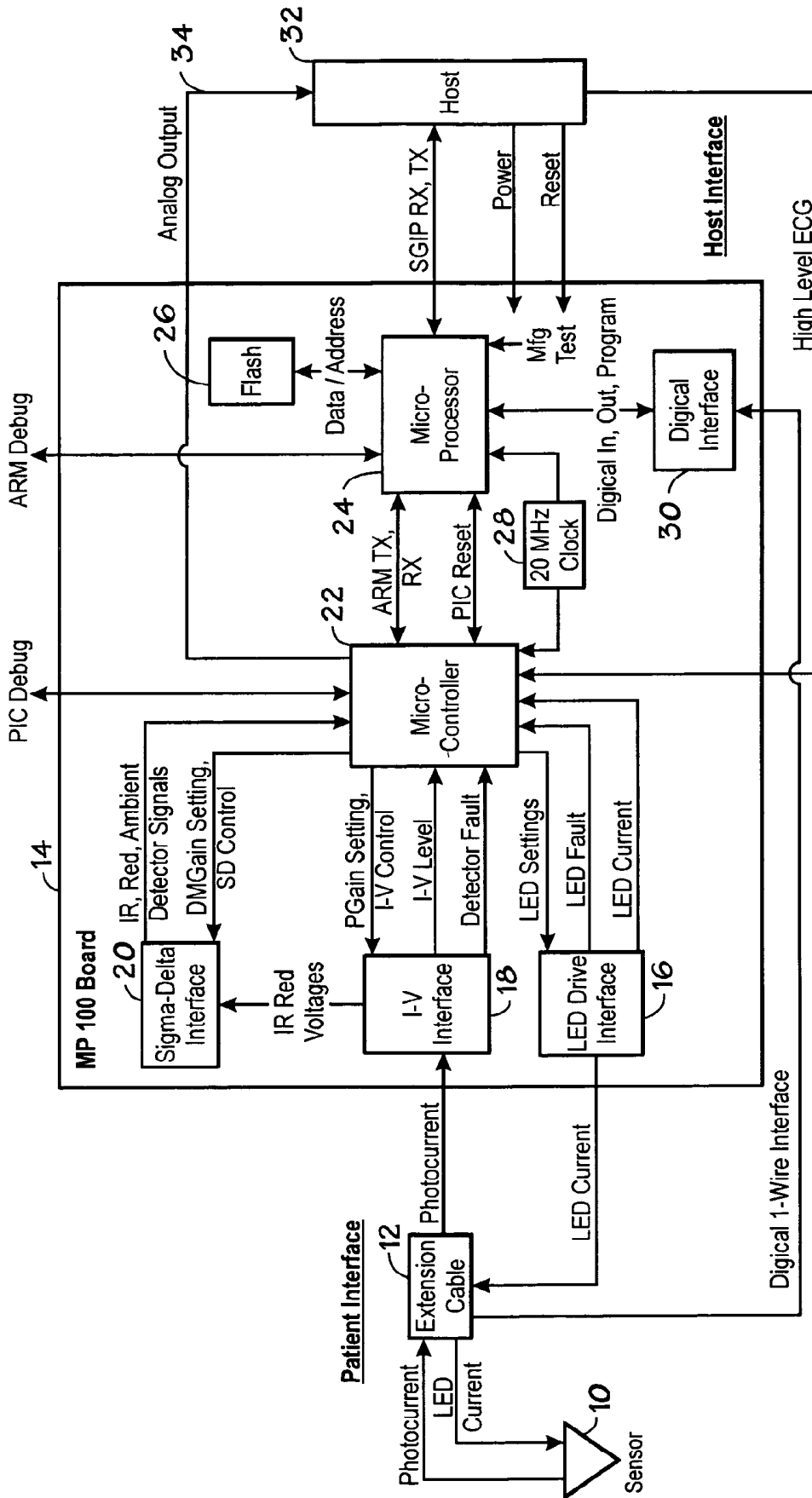

FIG. 1

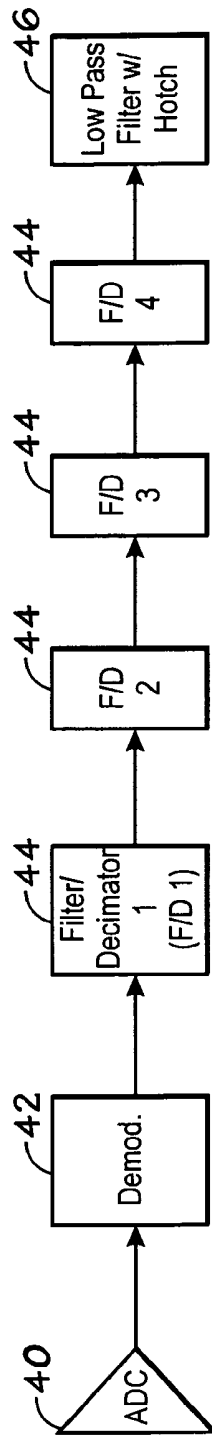
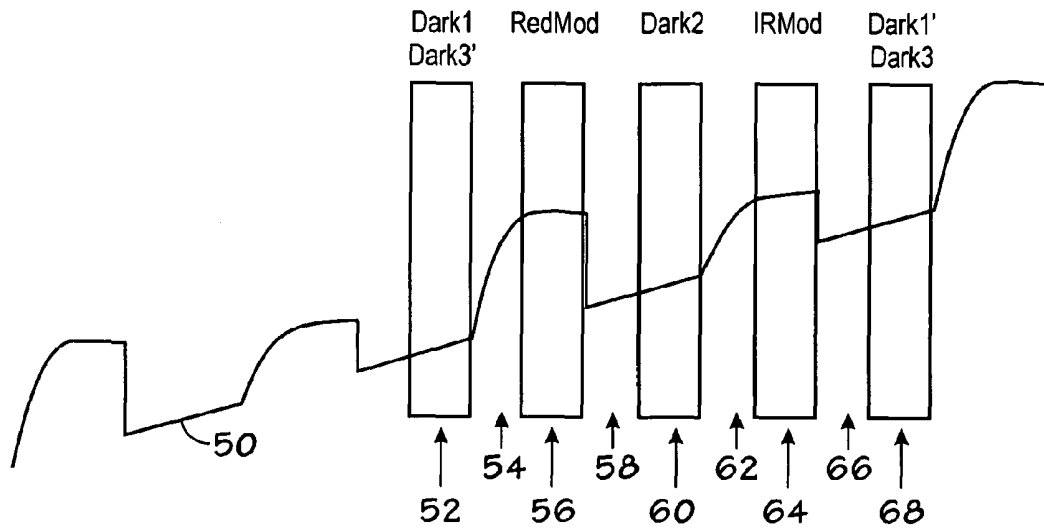

FIG. 2



$$Red = RedMod - \frac{Dark1 + Dark2}{2}$$

$$IR = IRMod - \frac{Dark2 + Dark3}{2}$$

FIG. 3

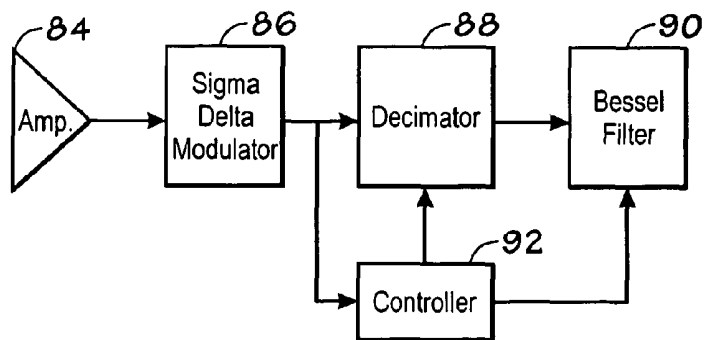

FIG. 4

OXIMETER AMBIENT LIGHT CANCELLATION

CROSS-REFERENCE TO RELATED APPLICATION

This application is a continuation of application Ser. No. 12/172,981, filed Jul. 14, 2008, in the name of Ethan Petersen, now U.S. Pat. No. 8,315,684 which granted on Nov. 20, 2012 and assigned to Covidien LP, which is a continuation of application Ser. No. 11/495,415, filed Jul. 28, 2006, in the name of Ethan Petersen, now U.S. Pat. No. 7,400,919 which granted on Jul. 15, 2008 and assigned to Covidien LP, which is a divisional of application Ser. No. 10/787,854, filed Feb. 25, 2004, in the name of Ethan Petersen, now U.S. Pat. No. 7,190,985, which granted on Mar. 13, 2007 and assigned to Covidien LP, which are incorporated herein by reference in their entirety.

BACKGROUND OF THE INVENTION

The present invention relates to oximeters, and in particular to techniques for ambient light cancellation in pulse oximeters.

Pulse oximetry is typically used to measure various blood flow characteristics including, but not limited to, the blood-oxygen saturation of hemoglobin in arterial blood, the volume of individual blood pulsations supplying the tissue, and the rate of blood pulsations corresponding to each heartbeat of a patient. Measurement of these characteristics has been accomplished by use of a non-invasive sensor which scatters light through a portion of the patient's tissue where blood perfuses the tissue, and photoelectrically senses the absorption of light in such tissue. The amount of light absorbed is then used to calculate the amount of blood constituent being measured.

The light scattered through the tissue is selected to be of one or more wavelengths that are absorbed by the blood in an amount representative of the amount of the blood constituent present in the blood. The amount of transmitted light scattered through the tissue will vary in accordance with the changing amount of blood constituent in the tissue and the related light absorption. For measuring blood oxygen level, such sensors have typically been provided with a light source that is adapted to generate light of at least two different wavelengths, and with photodetectors sensitive to both of those wavelengths, in accordance with known techniques for measuring blood oxygen saturation.

Known non-invasive sensors include devices that are secured to a portion of the body, such as a finger, an ear or the scalp. In animals and humans, the tissue of these body portions is perfused with blood and the tissue surface is readily accessible to the sensor.

One problem with oximeter measurements is that in addition to receiving the light that was directed at the tissue, ambient light is also detected by the photodetector. Attempts can be made to block out ambient light, but some amount of ambient light will typically be detected. One particular concern is the light at the power line frequency of fluorescent or other lights, which is 60 Hz in the United States and 50 Hz in Europe and other countries.

Since a single photodetector is typically used, the light of different wavelengths, such as red and infrared, is time multiplexed. The detected signal must be demultiplexed. The demultiplexing frequency must be high enough so that it is much larger than the pulse rate. However, choosing a demultiplexing frequency is also impacted by the ambient light

interference. One issue is the aliasing of harmonics of the AC power line frequency. U.S. Pat. No. 5,713,355 discusses a technique of altering the demultiplexing frequency depending upon the amount of ambient interference detected at each frequency.

U.S. Pat. No. 5,885,213 discusses subtracting a dark signal (detected ambient light) from the detected light signal. This is accomplished by leaving both the red and infrared light emitters off, in between turning them on, so that a "dark" signal supposedly composed of the ambient light present can be detected. This can then be subtracted from the desired signal. Other examples of patents dealing with the ambient light issue are U.S. Pat. Nos. 6,385,471, 5,846,190 and 4,781,195.

U.S. Pat. No. 6,449,501 discusses using a notch filter to filter out line frequency. However, the sampling rate is described as being set to twice the fundamental frequency of the power line interference, leaving higher harmonics of the power line interference as a problem, and it is unclear how the interference can be filtered without filtering the modulation frequency. Another example of a notch filter being used is set forth in U.S. Pat. No. 4,802,486, which uses a notch filter for the EKG signal.

BRIEF SUMMARY OF THE INVENTION

The present invention provides a pulse oximeter method and apparatus which provides (1) a notch filter at a distance between a demodulation frequency and a common multiple of commonly used power line frequencies (50, 60, 100, and 120) and also (2) a demodulation frequency greater than a highest pulse rate of a person and lower than any harmonic of 50, 60, 100, or 120 Hz. The invention thus allows the filtering of a significant source of ambient light interference, while choosing an optimum demodulation frequency that avoids interference from the notch filter or from harmonics of the power line interference.

In one embodiment, the common multiple is 1200, with the demodulation frequency being between 5 and 20 Hz away from 1200, preferably approximately 1211 in one embodiment.

In another aspect of the invention, dark signals, or ambient light, are measured both before and after each of the light emitter wavelengths (red and infrared in one embodiment). Instead of simply subtracting one of the dark levels, the two dark levels are averaged and then subtracted from the detected signal. This compensates for a variation in ambient light during the detected signal, reducing the effect of power line interference or any other low frequency interference.

In another aspect of the present invention, digital filtering and decimation are done in the digital domain. When there is a change in a gain setting on the front end hardware, or in the LED power, the filters are preloaded to put values in their memory to correspond to an estimate of the settled value of the output at the new gain or power settings. This preloading speeds up when valid data will be available at the output of the filter.

BRIEF DESCRIPTION OF THE DRAWINGS

FIG. 1 is a block diagram of an oximeter incorporating the present invention.

FIG. 2 is a block diagram of a portion of the digital manipulations in one embodiment of the invention, including a notch filter.

FIG. 3 is a diagram illustrating the multiple dark levels that are averaged in an embodiment of the invention.

FIG. 4 is a diagram illustrating the preloading of the digital filter and decimator according to an embodiment of the present invention.

DETAILED DESCRIPTION OF THE INVENTION

Overall System

FIG. 1 illustrates an embodiment of an oximetry system incorporating the present invention. A sensor 10 includes red and infrared LEDs and a photodetector. These are connected by a cable 12 to a board 14. LED drive current is provided by an LED drive interface 16. The received photocurrent from the sensor is provided to an I-V interface 18. The IR and red voltages are then provided to a sigma-delta interface 20 incorporating the present invention. The output of sigma-delta interface 20 is provided to a microcontroller 22. Microcontroller 22 includes flash memory for a program, and EEPROM memory for data. The oximeter also includes a microprocessor chip 24 connected to a flash memory 26. Finally, a clock 28 is used and an interface 30 to a digital calibration in the sensor 10 is provided. A separate host 32 receives the processed information, as well as receiving an analog signal on a line 34 for providing an analog display.

Notch Filter

FIG. 2 shows an analog-to-digital converter 40 which provides a digital signal to be manipulated by microcontroller 22 of FIG. 1. The microprocessor would include a demodulator 42, four stages of filter/decimators 44, a low pass filter with a notch 46, as well as other blocks for digital manipulation of the signals and calculation of oxygen saturation as is well known in the art. Only the red channel is shown after the demodulation, but a similar channel is used for the IR signal.

Notch filter 46 deals with power line interference which, in the United States, comes from lights which operate on 60 Hz or 120 Hz, depending upon the power requirements. Europe and other areas use 50 Hz and 100 Hz. A common multiple of 50, 60, 100, and 120 Hz is 1200 Hz. The modulation bandwidth is chosen to be higher than the highest possible human pulse rate, preferably higher than 5 Hz. At the same time, it is chosen to be lower than any harmonic of the power line interference signals. Twenty hertz is chosen as a desirable upper limit because a second harmonic of 2450 will alias in at 2025 Hz. In one embodiment, the modulation frequency chosen is 1211.23 Hz. This is 11.23 Hz distant from 1200 Hz. (within a range of 5-20 Hz). Accordingly, in a preferred embodiment, a zero is provided in the notch filter at 11.23 Hz. The low pass filter with notch (46), in one embodiment, is an 8 pole Bessel filter with a notch at 11.25 Hz.

The present invention thus provides an effective means of eliminating interference from power line interference, such as the ripple on fluorescent lights which can alias onto the detected signal. Although anti-aliasing filters have been provided in hardware before a demodulator, it is difficult to make these effective, and thus there will be some residual line interference in the detected signal to be dealt with in the digital domain.

Averaging Ambient Dark Levels to Reduce Low Frequency Interference

FIG. 3 illustrates another aspect of the present invention, reducing ambient interference by averaging the ambient dark levels before and after a sampling period to account for low frequency interference from power lines or other sources. FIG. 3 shows a signal at a sampling rate of 2400. The upward sloping line in FIG. 3 is due to 60 Hz power line interference. It is desirable to eliminate the effect of this upward slope (which will be downward on other parts of the 60 Hz (or 50 Hz, etc.) signal.

FIG. 3 shows a detected signal during different periods of modulation. The detected signal level is illustrated by a line 50. During a first dark period 52, neither the red nor IR LED are on, allowing a sampling of the dark, or ambient, light. After this sampling, during a time period 54, the red LED is turned on, with signal 50 rising during this period as the red LED comes on to its full intensity. During the time period 56, the detected signal corresponds to the red LED being on.

After the red LED is turned off and the signal decays during a period 58, a second dark period 60 is sampled.

Subsequently, the IR LED is turned on during a period 62, and sampled during a period 64. It is turned off and the signal decays during a period 66, with a third dark sample being taken during a period 68. The third dark sample also corresponds to the first dark period 52, as the process repeats itself.

As can be seen from FIG. 3, if only one of the dark levels is used, an inaccurate ambient level may be measured if the ambient level is varying, such as due to low frequency interference. By averaging the dark periods before and after the sampling period for a particular wavelength, a more accurate measurement of the ambient dark level signal is obtained. For example, the ambient interference during the red modulation period 56 is determined by measuring the dark 1 signal during period 52 and the dark 2 signal during period 60 and averaging these signals. Similarly, for the infrared modulation period 64, the dark 2 signal during period 60 and the dark 3 signal during period 68 are averaged and subtracted from the detected IR signal to eliminate the ambient interference. All of these calculations are done in the digital domain by microcontroller 22 of FIG. 1.

Preloading Decimation and Bessel Filters

FIG. 4 illustrates another aspect of the present invention where filters and software are preloaded. Before the analog input signal is processed through the sigma-delta modulator and multi-bit analog digital converter, it is typically amplified in a hardware amplifier 84. After processing by the sigma-delta modulator 86 and conversion into digital domain, it is decimated to reduce the sample rate by a decimator 88 and filtered by a Bessel filter 88. A controller 92 pre-loads the memories of the Bessel filter and decimator with an estimate of what the settled value of the output would be. This will significantly reduce the settling time of the filter after a step change in its input. Such a step change in the input can occur from a change in the gain settings of the amplifier 84. Alternately, a step change can be the result of a change in the particular LED being activated, the power of the LED, or other gain settings of the front end hardware. Since the controller 92 would be activating such changes, it will have the knowledge of when to pre-load the filter and decimator with the appropriate values.

Although these are shown as blocks in FIG. 4, it is understood that in the preferred embodiment this is done by a software program which functions as controller 92, filter 88 and decimator 90. This preloading of the filter and decimator provides that valid data is available sooner by shortening the settling time.

As will be understood by those skilled in the art, the present invention may be embodied in other specific forms without departing from the essential characteristics thereof. For example, more than two different wavelengths of light could be used. Alternately, a different demodulation frequency could be chosen. In addition, the notch filtering can be done either before or after other digital processing of the detected signal. Accordingly, the foregoing description is intended to be illustrative, but not limiting, of the scope of the invention which is set forth in the following claims.

What is claimed is:

1. A method for operating a pulse oximetry system, comprising:

alternately generating light with a sensor at two wavelengths using a modulation frequency that is a predetermined distance from a common multiple of 50, 60, 100, and 120, where the predetermined distance is greater than a highest pulse rate of a person and lower than a distance of any harmonic of 50, 60, 100, or 120;

receiving an analog sensor signal from the sensor that corresponds to received light;

amplifying the analog sensor signal to provide an amplified analog sensor signal;

modulating the amplified analog sensor signal with a sigma-delta modulator to provide a modulated signal;

converting the modulated signal into a digital signal with a multiple bit analog-to-digital converter;

decimating the digital signal with a decimator to provide a decimated signal;

filtering the decimated signal with a digital filter to provide a filtered signal; and

preloading the decimator and digital filter with an estimate of a settled output value.

2. The method of claim 1 wherein processing the received light signal comprises digitizing the processed signal.

3. The method of claim 1 wherein the common multiple comprises 1200.

4. The method of claim 1 wherein the predetermined distance is between 5 and 20 hertz.

5. The method of claim 1 wherein the predetermined distance is approximately 11 hertz.

6. The method of claim 1 comprising determining a physiological parameter based at least in part on the filtered signal.

7. The method, as set forth in claim 1, wherein amplifying comprises using a hardware amplifier.

8. The method, as set forth in claim 1, wherein filtering comprises using a Bessel filter.

9. The method, as set forth in claim 1, wherein preloading comprises using a controller.

10. A pulse oximetry system, comprising:
a first processor board, the first processor board comprising:

an interface for receiving an analog sensor signal;

a sigma-delta modulator configured to receive the sensor signal and to provide a modulated signal;

an analog-to-digital converter configured to convert the modulated signal into a digital signal;

a decimator configured to receive the digital signal and output a decimated signal operated on by a digital filter, wherein the first processor board comprises a controller is configured to preload the decimator and the digital filter;

a processor configured to receive the decimated signal and provide an output related to a physiological parameter; and

a second processor board comprising an interface for receiving the output related to the physiological parameter from the first processor board.

11. The pulse oximetry system, as set forth in claim 10, wherein the first processor board comprises a hardware amplifier configured to amplify the sensor signal.

12. The pulse oximetry system, as set forth in claim 10, wherein the controller is configured to preload the decimator and the digital filter after a step change in the decimated signal.

13. The pulse oximetry system, as set forth in claim 10, wherein the controller is configured to preload the decimator and the digital filter in response to a change in a gain setting of the amplifier.

14. The pulse oximetry system, as set forth in claim 10, wherein the controller is configured to preload the decimator and the digital filter in response to a change in an LED associated with the sensor signal being activated.

15. The pulse oximetry system, as set forth in claim 10, wherein the controller is configured to preload the decimator and the digital filter in response to a power change in an LED associated with the analog sensor signal.

16. The pulse oximetry system, as set forth in claim 10, wherein the controller is configured to preload the decimator and the digital filter in response to the controller changing a setting of the oximeter apparatus.

17. The pulse oximetry system, as set forth in claim 10, wherein first board comprises a processor comprising executable instructions configured to

control light to be alternately driven into a tissue site using a modulation frequency to alternate between a first period of time when a first wavelength is being generated, a dark period of time when no light is being generated, and a second period of time when a second wavelength is being generated;

estimate a first level of ambient light in a signal received from the tissue site during the first period of time by averaging detected light received during the dark periods before and after the first period;

estimate a second level of ambient light in the signal received from the tissue site during the second period of time by averaging detected light received during the dark periods before and after the second period;

calculate a total light signal by subtracting the first level of ambient light from the signal received from the tissue site generated during the first period of time and subtracting the second level of ambient light from the signal received from the tissue site generated during the second period of time; and

calculate at least one patient characteristic based on the total light signal.

18. A pulse oximetry system, comprising:

a first processor board, the first processor board comprising:

a first interface for receiving an analog sensor signal from a sensor;

a second interface for receiving calibration information from the sensor;

a sigma-delta interface configured to receive the sensor signal and to provide a modulated signal;

an analog-to-digital converter configured to convert the modulated signal into a digital signal;

a decimator configured to receive the digital signal and output a decimated signal operated on by a digital filter, wherein the first processor board comprises a controller configured to preload the decimator and the digital filter; a processor configured to receive the decimated signal and provide an analog output; and

a second processor board comprising a host interface for receiving the analog output from the first processor board.

19. The pulse oximetry system, as set forth in claim 18, comprising control circuitry for providing a display based at least in part on the analog output.

专利名称(译)	血氧计环境光消除		
公开(公告)号	US8874181	公开(公告)日	2014-10-28
申请号	US13/663244	申请日	2012-10-29
[标]申请(专利权)人(译)	柯惠有限合伙公司		
申请(专利权)人(译)	COVIDIEN LP		
当前申请(专利权)人(译)	COVIDIEN LP		
[标]发明人	PETERSEN ETHAN SHEA WILLIAM CHEW BRADFORD B		
发明人	PETERSEN, ETHAN SHEA, WILLIAM CHEW, BRADFORD B.		
IPC分类号	A61B5/00 A61B5/1455 A61B5/0205 A61B5/024		
CPC分类号	A61B5/7203 A61B5/7225 A61B5/725 A61B5/02416 A61B5/7228 A61B5/0205 A61B5/14552 A61B5/7278 A61B5/14551		
其他公开文献	US20130123593A1		
外部链接	Espacenet USPTO		

摘要(译)

一种脉冲血氧计方法和装置，其在调制频率和常用电力线频率（50,60,100和120）的公倍数之间的距离处提供（1）陷波滤波器，并且还提供（2）大于的解调频率。一个人的最高脉冲率，低于50,60,100或120 Hz的任何谐波，以滤除环境光干扰，同时选择最佳解调频率，避免陷波滤波器的干扰或线路干扰的谐波。此外，在每个光发射器波长之前和之后测量用于任何低频干扰（例如电力线干扰）的环境光，然后从检测到的信号中减去环境光的平均值。

