



US006540689B1

(12) **United States Patent**
Orr et al.

(10) **Patent No.:** **US 6,540,689 B1**
(45) **Date of Patent:** **Apr. 1, 2003**

(54) **METHODS FOR ACCURATELY, SUBSTANTIALLY NONINVASIVELY DETERMINING PULMONARY CAPILLARY BLOOD FLOW, CARDIAC OUTPUT, AND MIXED VENOUS CARBON DIOXIDE CONTENT**

FOREIGN PATENT DOCUMENTS

DE	28 49 217 A1	5/1980
WO	96/24285	8/1996
WO	98/12963	4/1998

OTHER PUBLICATIONS

H. Blomquist et al., *A Non-Invasive Technique for Measurement of Lung Perfusion*, Intensive Care Medicine 1986; 12:172.

R.J. Bosman et al, *Non-Invasive Pulmonary Blood Flow Measurement by Means of CO₂ Analysis Of Expiratory Gases*, Intensive Care Medicine 1991, 17:98-102.

A. Gedeon, *Non-Invasive Pulmonary Blood Flow for Optimal Peep*, ICOR AB, Ulvsundavagen 178 B, S-161 30 Bromma, Sweden, pp. 49-58.

(List continued on next page.)

Primary Examiner—Robert L. Nasser

(74) *Attorney, Agent, or Firm*—TraskBritt

(57) **ABSTRACT**

A method of noninvasively determining the pulmonary capillary blood flow or cardiac output of a patient, including the use of rebreathing techniques to measure the respiratory flow and carbon dioxide pressure of the patient's breathing. These measurements are used to calculate carbon dioxide elimination and an indicator of the carbon dioxide content of the patient's blood, such as the end-tidal pressure of carbon dioxide (PetCO₂), CaCO₂, or pCO₂. The location and orientation of a best-fit line through the carbon dioxide elimination data and the data of the indicator of carbon dioxide content is determined by linear regression or by plotting the carbon dioxide elimination data against the data of the indicator of carbon dioxide content. At least one set of the data is modified and at least one other determination of the best-fit line made to find a data set that correlates most closely to the best-fit line. The data may be modified by filtering or clustering. The slope of the best-fit line that correlates most closely to the data is then used to determine the pulmonary capillary blood flow or cardiac output of the patient. When the indicator of carbon dioxide content is CaCO₂, the negative of the slope of the best-fit line is equal to the pulmonary capillary blood flow of the patient.

(75) Inventors: **Joseph A. Orr**, Park City, UT (US);
Kai Küick, Hamburg (DE)

(73) Assignee: **NTC Technology, Inc.**, Wilmington, DE (US)

(*) Notice: Subject to any disclaimer, the term of this patent is extended or adjusted under 35 U.S.C. 154(b) by 0 days.

(21) Appl. No.: **09/510,702**
(22) Filed: **Feb. 22, 2000**

(51) **Int. Cl.**⁷ **A61B 5/00**
(52) **U.S. Cl.** **600/529; 600/532; 600/504**
(58) **Field of Search** 600/504, 529,
600/532; 128/204.23

(56) **References Cited**

U.S. PATENT DOCUMENTS

4,221,224 A	9/1980	Clark	
4,463,764 A	8/1984	Anderson et al.	
5,060,656 A	10/1991	Howard	
5,069,220 A	12/1991	Caparie et al.	
5,117,674 A	6/1992	Howard	
5,178,155 A	1/1993	Mault	
5,285,794 A	2/1994	Lynch	
5,299,579 A	4/1994	Gedeon et al.	
5,402,796 A	4/1995	Packer et al.	
5,632,281 A	5/1997	Rayburn	
5,836,300 A	11/1998	Mault	
5,971,934 A	10/1999	Scherer et al.	
6,059,732 A *	5/2000	Orr et al.	600/532
6,102,868 A	8/2000	Banner et al.	
6,135,107 A *	10/2000	Mault	600/532

(List continued on next page.)

114 Claims, 6 Drawing Sheets

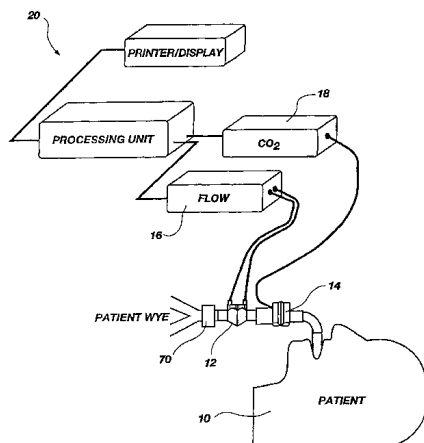

U.S. PATENT DOCUMENTS

6,200,271	B1 *	3/2001	Kuck et al.	600/532
6,210,342	B1 *	4/2001	Kuck et al.	600/504
6,217,524	B1 *	4/2001	Orr et al.	600/504
6,238,351	B1 *	5/2001	Orr et al.	600/532
6,394,962	B1 *	5/2002	Gama De Abreau et al.	600/532
6,402,697	B1 *	6/2002	Calkins et al.	600/532

OTHER PUBLICATIONS

Capek, J.M., *Noninvasive Measurement of Cardiac Output Using Partial CO₂ Rebreathing* [Dissertation], Rensselaer Polytechnic Institute (1988) 28:351 p. (due to large number of pages, only table of contents and abstract have been copied).

Capek, J.M., et al., *Noninvasive Measurement of Cardiac Output Using Partial CO₂ Rebreathing*, IEEE Trans. Biomed. Eng. (1988) 35(9):653-61.

Davies, Gerald G., et al., *Continuous Fick cardiac output compared to thermodilution cardiac output*, Critical Care Medicine (1986) 14(10):881-85.

Elliot, C. Gregory, et al., *Complications of Pulmonary Artery Catheterization in the Care of Critically Ill Patients*, Chest (1979) 76:647-52.

Fick, A., *Über die Messung des Blutquantums in den Herzventrikeln*, Sitzungsbericht der Physikalisch-Medizinischen Gesellschaft zu Würzburg (1870) 36 (2 pages).

Gama de Abreu, Marcelo, et al., *Measurement of Pulmonary Capillary Blood Flow for Trending Mixed Venous Blood Oxygen Saturation and Oxygen Delivery*, Crit. Care Med. (1998), vol. 26, No. 1 (Suppl.), A106, Abstract #238, (1 page).

Gama de Abreu, Marcelo, et al., *Is the Partial CO₂ Rebreathing Technique a Useful Tool for Trending Pulmonary Capillary Blood Flow During Adjustments of Peep?*, Crit. Care Med. (1998), vol. 26, No. 1 (Suppl.), A106, Abstract #237, (1 page).

Gama de Abreu, et al., *Partial carbon dioxide rebreathing: A reliable technique for noninvasive measurement of non-shunted pulmonary capillary blood flow*, Crit. Care Med. (1997) 25(4):675-83.

Gedeon, A., et al., *Noninvasive Cardiac Output Determined with a New Method Based on Gas Exchange Measurements and Carbon Dioxide Rebreathing: A Study in Animals/Pigs*, J. Clin. Monit. (1992) 8(4):267-78.

Gedeon, A., et al., *A new method for noninvasive bedside determination of pulmonary blood flow*, Med. & Biol. Eng. & Comput. (1980) 18:411-418.

Guyton, A.E., et al., *Measurement of cardiac output by the direct Fick method*, In: *Cardiac output and its regulation*, W.B. Saunders Company (1973) 21-39.

Kyoku, I., et al. *Measurement of cardiac output by Fick method using CO₂ analyzer Servo*, Kyobu Geka. Japanese Journal of Thoracic Surgery (1988) 41(12):966-70.

Lynch, J., et al., *Comparison of a modified Fick method with thermodilution for determining cardiac output in critically ill patients on mechanical ventilation*, Intensive Care Med. (1990) 16:248-51.

Mahutte, C. Kees, et al., *Relationship of Thermodilution Cardiac Output to Metabolic Measurements and Mixed Venous Oxygen Saturation*, Chest (1993) 104(4):1236-42.

Miller, D.M., et al., *A Simple Method for the Continuous Noninvasive Estimate of Cardiac Output Using the Maxima Breathing System. A Pilot Study*, Anaesth. Intens. Care (1997) 25(1):23-28.

Österlung, B., et al., *A new method of using gas exchange measurements for the noninvasive determination of cardiac output: clinical experiences in adults following cardiac surgery*, Acta Anaesthesiol Scand (1995) 39:727-32.

Sackner, Marvin A., *Measurement of cardiac output by alveolar gas exchange*, Handbook of Physiology—The Respiratory System IV, Chapter 13, 233-55.

Spalding, H.K., et al., *Carbon Dioxide (CO₂) Elimination Rate Accurately Predicts Cardiac Output*, Anesthesiology (1997) 87(3A) (1 page).

Sprung, Charles L., et al., *Ventricular Arrhythmias During Swan-Ganz Catheterization of the Critically Ill*, Chest (1981) 79:413-15.

Taskar, V., et al., *Dynamics of Carbon Dioxide Elimination Following Ventilator Resetting*, Chest (1995) 108:196-202.

Winkler, Tilo, et al., *Pulmonary Capillary Blood Flow by Partial CO₂ Rebreathing: A Simulation Study Using a Bicompartamental Model of Gas Exchange*, Crit. Care Med. (1998), vol. 26, No. 1 (Suppl.), A105, Abstract #234, (1 page).

International Search Report of Dec. 8, 2000.

* cited by examiner

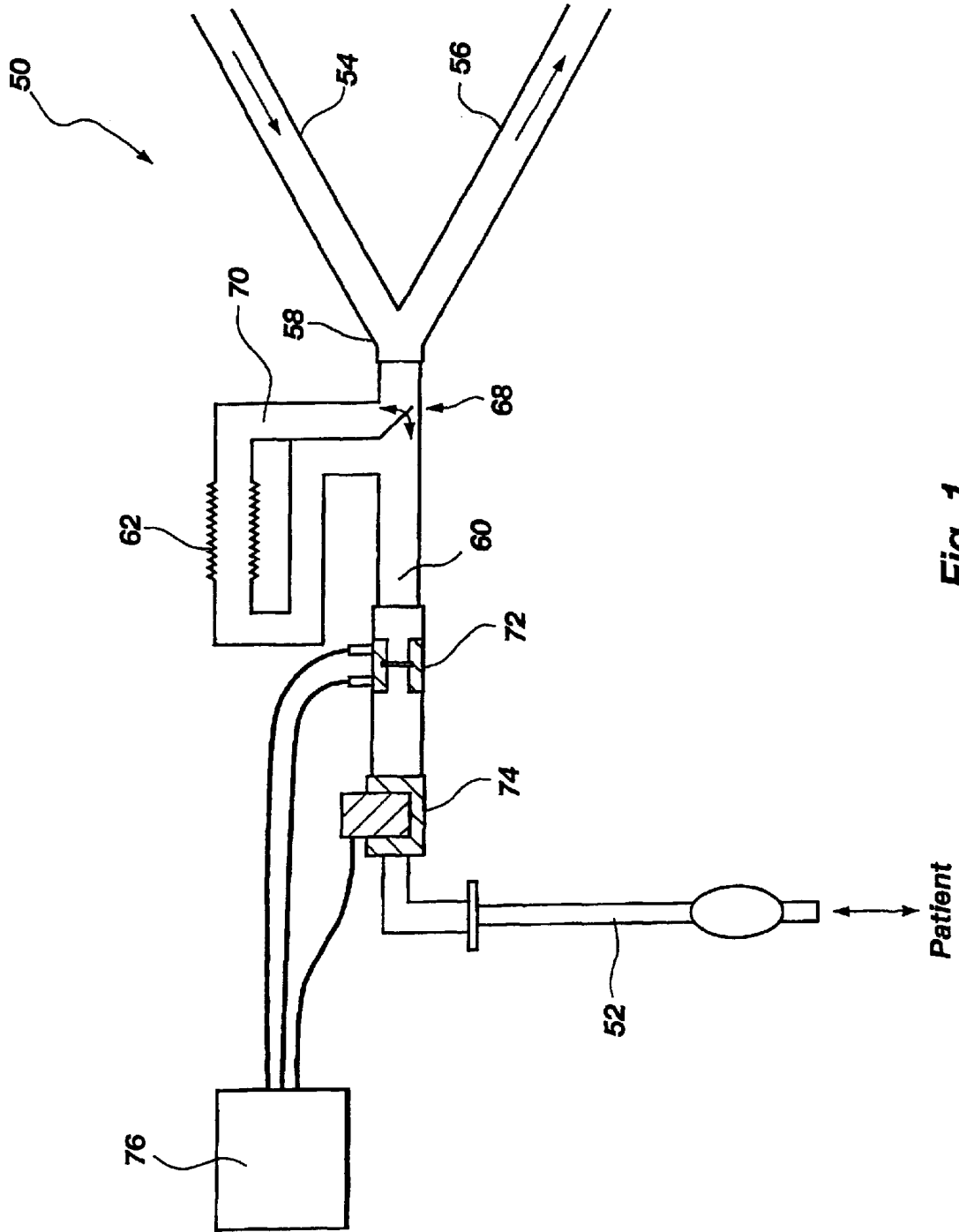

Fig. 1

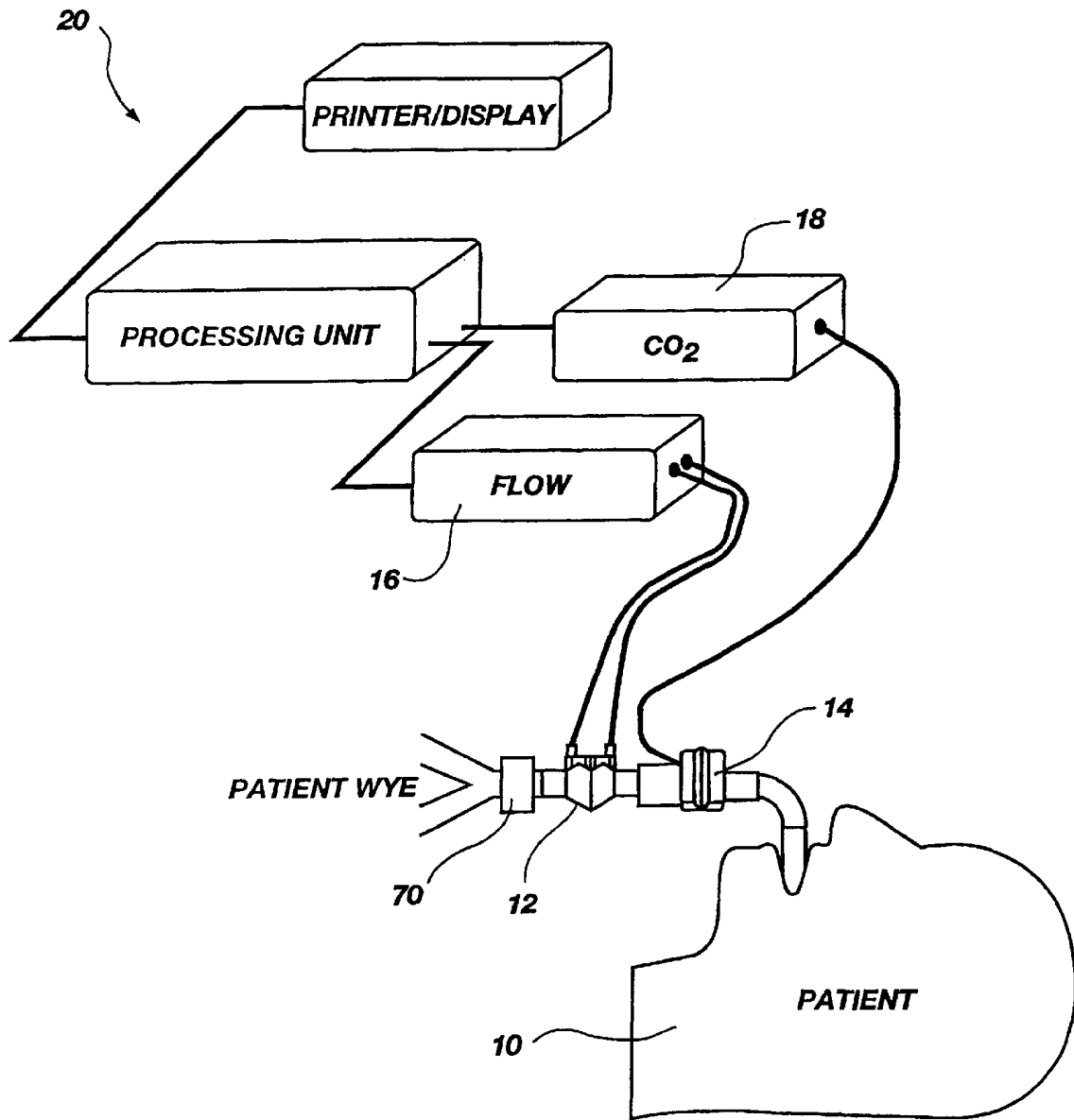

Fig. 2

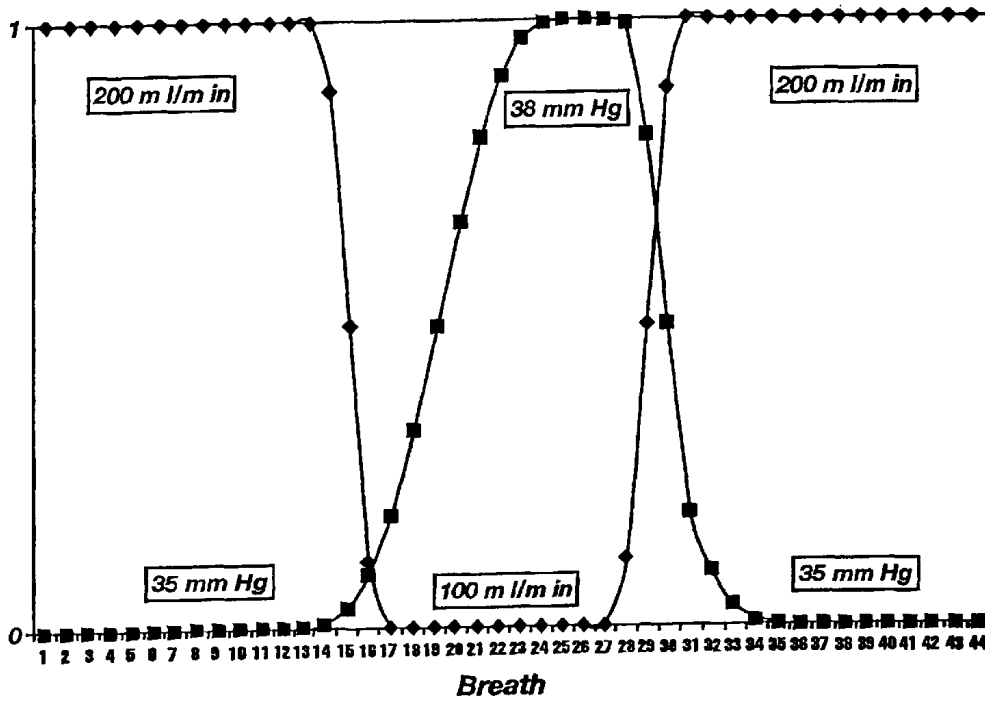

Fig. 3A

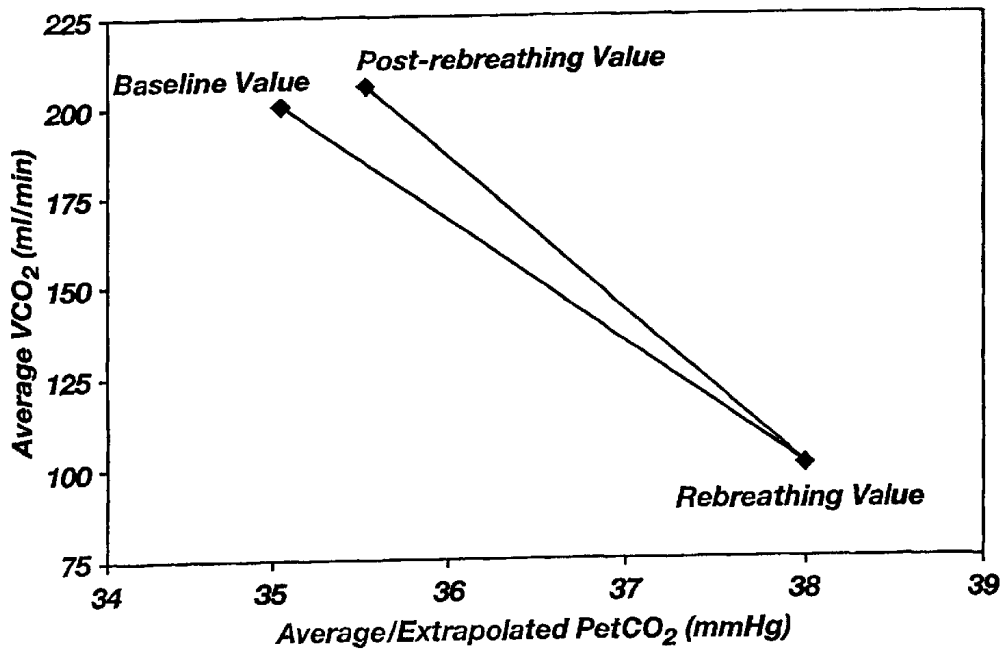

Fig. 3B

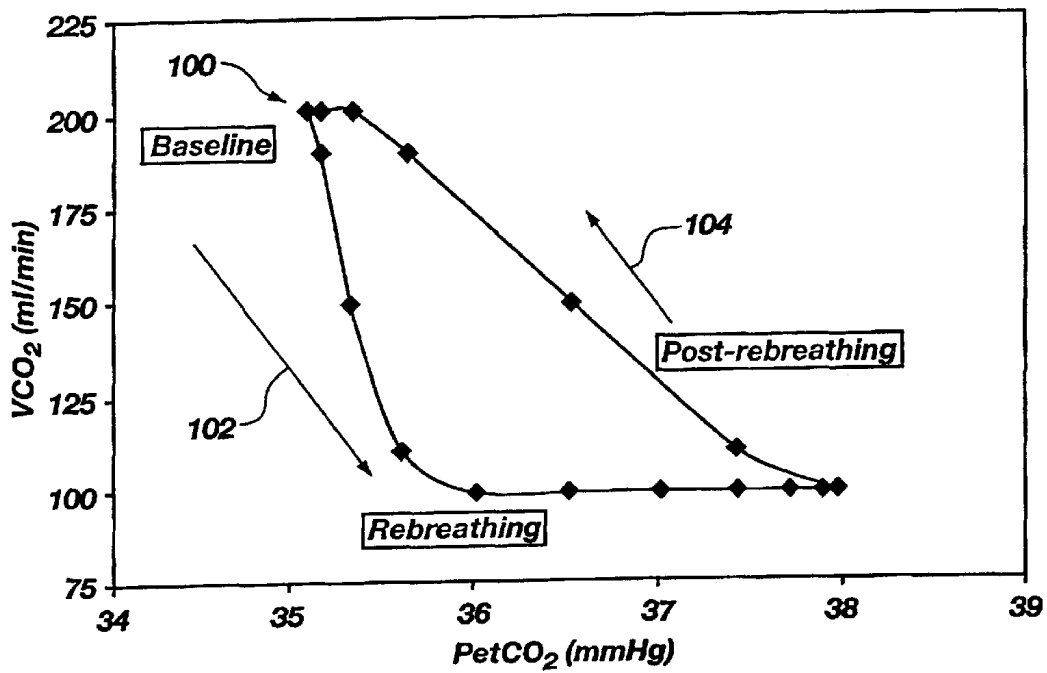

Fig. 3C

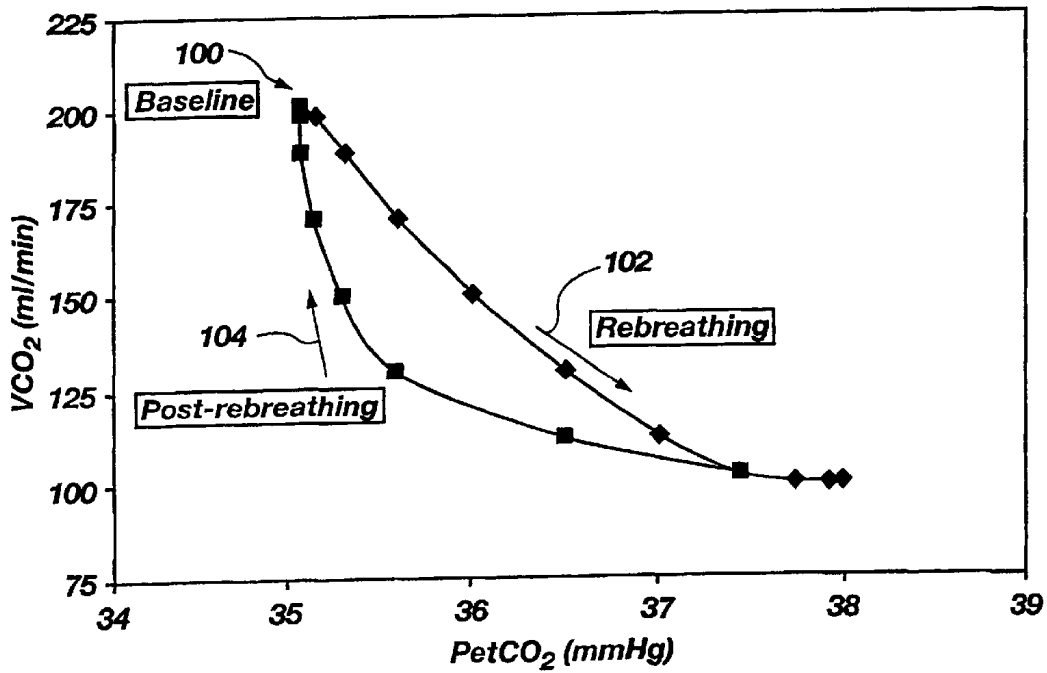

Fig. 3D

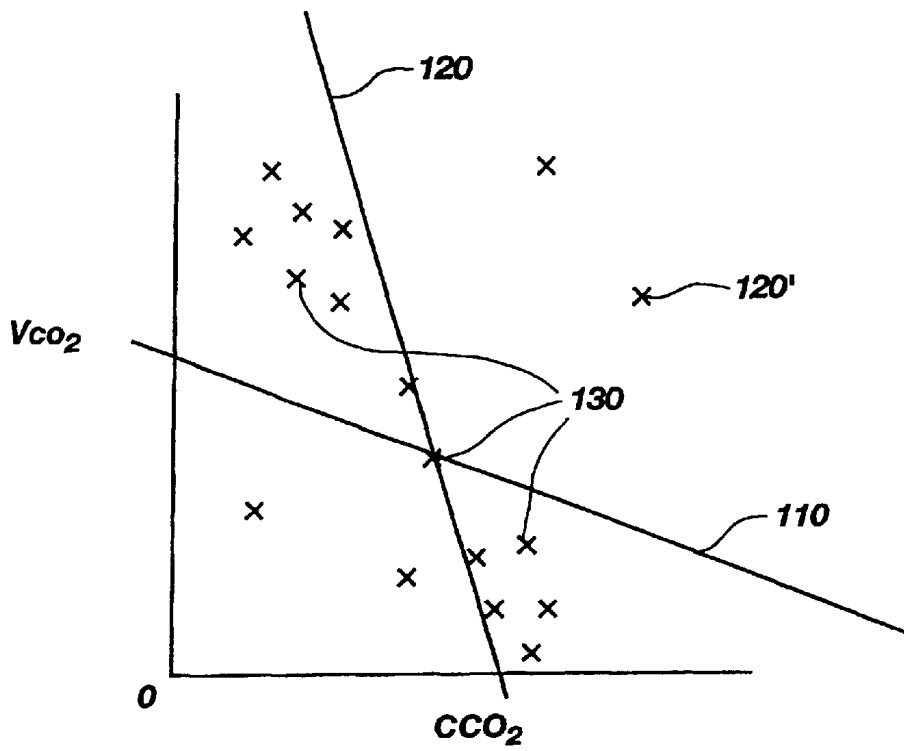

Fig. 4A

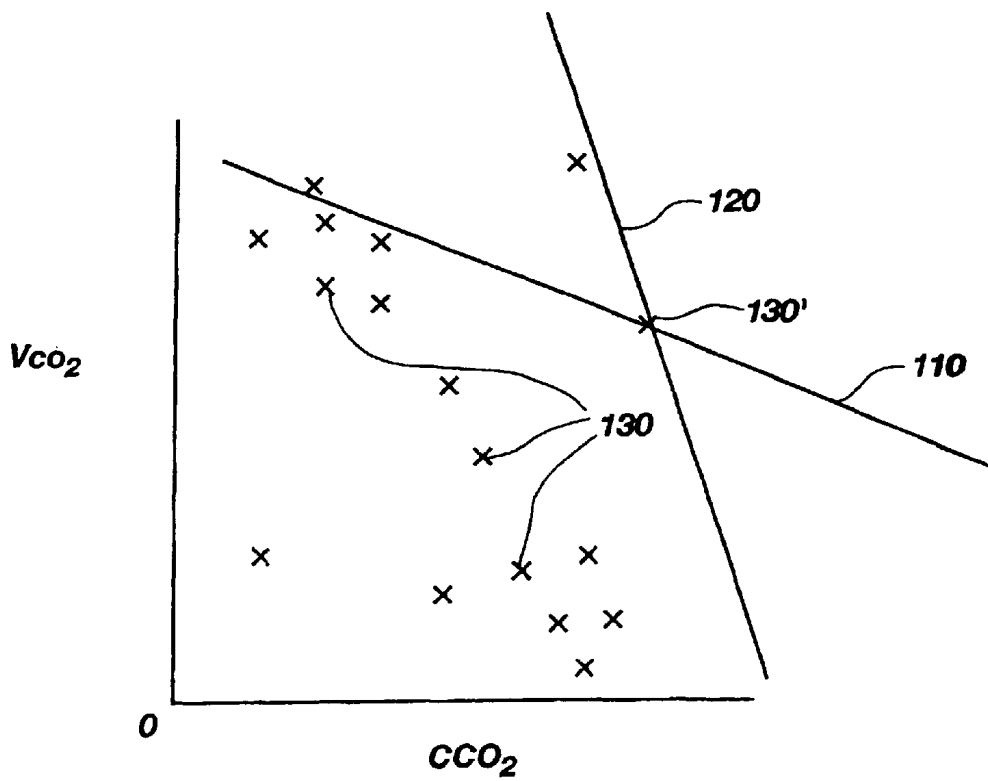

Fig. 4B

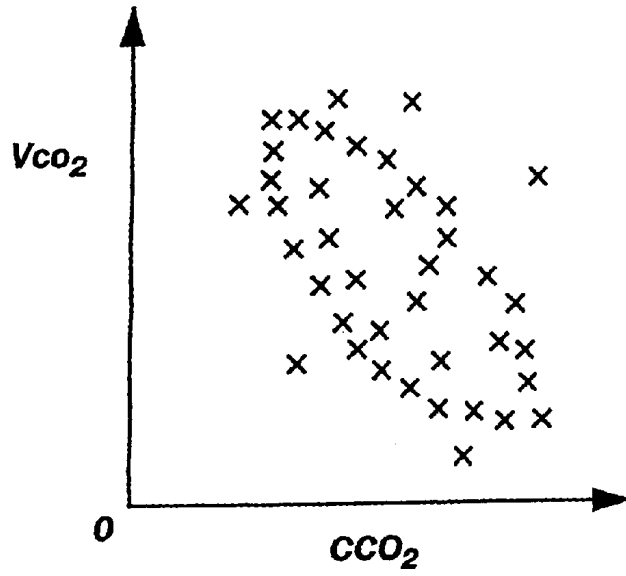

Fig. 5

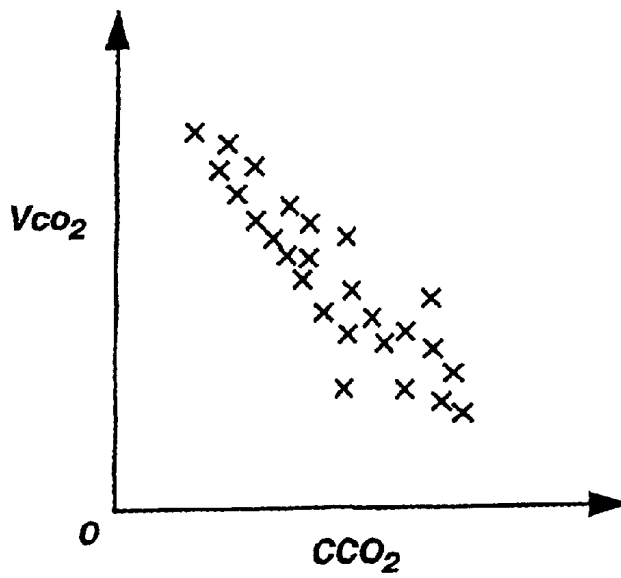

Fig. 6

**METHODS FOR ACCURATELY,
SUBSTANTIALLY NONINVASIVELY
DETERMINING PULMONARY CAPILLARY
BLOOD FLOW, CARDIAC OUTPUT, AND
MIXED VENOUS CARBON DIOXIDE
CONTENT**

BACKGROUND OF THE INVENTION

1. Field of the Invention

The present invention relates to methods for accurately, noninvasively measuring the pulmonary capillary blood flow (PCBF), cardiac output, and mixed venous carbon dioxide content of the blood of a patient. Particularly, the present invention relates to a method for noninvasively measuring pulmonary capillary blood flow or cardiac output that employs an algorithm to increase the accuracy of data upon which the pulmonary capillary blood flow or cardiac output measurement is based.

2. Background of Related Art

Carbon dioxide elimination (V_{CO_2}) is the volume of carbon dioxide (CO_2) excreted from the body of a patient during respiration. Conventionally, carbon dioxide elimination has been employed as an indicator of metabolic activity. Carbon dioxide elimination has also been used in rebreathing methods of determining pulmonary capillary blood flow and cardiac output.

The carbon dioxide Fick equation:

$$Q = V_{CO_2} / (C_vCO_2 - C_aCO_2), \quad (1)$$

where Q is cardiac output, C_vCO_2 is carbon dioxide content of the venous blood of the patient, and C_aCO_2 is the carbon dioxide content of the arterial blood of the patient, has been employed to noninvasively determine the pulmonary capillary blood flow or cardiac output of a patient. The carbon dioxide elimination of the patient may be noninvasively measured as the difference per breath between the volume of carbon dioxide inhaled during inspiration and the volume of carbon dioxide exhaled during expiration, and is typically calculated as the integral of the carbon dioxide signal, or the fraction of respiratory gases that comprises carbon dioxide, or "carbon dioxide fraction", times the rate of flow over an entire breath.

The partial pressure of end-tidal carbon dioxide ($P_{et}CO_2$ or $etCO_2$) is also measured in rebreathing processes. The partial pressure of end-tidal carbon dioxide, after correcting for any deadspace, is typically assumed to be approximately equal to the partial pressure of carbon dioxide in the alveoli (P_{ACO_2}) of the patient or, if there is no intrapulmonary shunt, the partial pressure of carbon dioxide in the arterial blood of the patient (P_aCO_2).

Rebreathing is typically employed either to noninvasively estimate the carbon dioxide content of mixed venous blood (as in total rebreathing) or to obviate the need to know the carbon dioxide content of the mixed venous blood (by partial rebreathing). Rebreathing processes typically include the inhalation of a gas mixture that includes carbon dioxide. During rebreathing, the carbon dioxide elimination of the patient decreases to a level less than during normal breathing. Rebreathing during which the carbon dioxide elimination decreases to near zero is typically referred to as total rebreathing. Rebreathing that causes some decrease, but not a total cessation of carbon dioxide elimination, is typically referred to as partial rebreathing.

Rebreathing is typically conducted with a rebreathing circuit, which causes a patient to inhale a gas mixture that

includes carbon dioxide. FIG. 1 schematically illustrates an exemplary rebreathing circuit 50 that includes a tubular airway 52 that communicates air flow to and from the lungs of a patient. Tubular airway 52 may be placed in communication with the trachea of the patient by known intubation processes, or by connection to a breathing mask positioned over the nose and/or mouth of the patient. A flow meter 72, which is typically referred to as a pneumotachometer, and a carbon dioxide sensor 74, which is typically referred to as a capnometer, are disposed between tubular airway 52 and a length of hose 60 and are exposed to any air that flows through rebreathing circuit 50. Both ends of another length of hose, which is referred to as deadspace 70, communicate with hose 60. The two ends of deadspace 70 are separated from one another by a two-way valve 68, which may be positioned to direct the flow of air through deadspace 70. Deadspace 70 may also include an expandable section 62. A Y-piece 58, disposed on hose 60 opposite flow meter 72 and carbon dioxide sensor 74, facilitates the connection of an inspiratory hose 54 and an expiratory hose 56 to rebreathing circuit 50 and the flow communication of the inspiratory hose 54 and expiratory hose 56 with hose 60. During inhalation, gas flows into inspiratory hose 54 from the atmosphere or a ventilator (not shown). During normal breathing, valve 68 is positioned to prevent inhaled and exhaled air from flowing through deadspace 70. During rebreathing, valve 68 is positioned to direct the flow of exhaled and inhaled gases through deadspace 70.

The rebreathed air, which is inhaled from deadspace 70 during rebreathing, includes air that has been exhaled by the patient (i.e., carbon dioxide-rich air).

During total rebreathing, substantially all of the gas inhaled by the patient was expired during the previous breath. Thus, during total rebreathing, the partial pressure of end-tidal carbon dioxide ($P_{et}CO_2$ or $etCO_2$) is typically assumed to be equal to or closely related to the partial pressure of carbon dioxide in the arterial (P_aCO_2), venous (P_vCO_2), or alveolar (P_{ACO_2}) blood of the patient. Total rebreathing processes are based on the assumption that neither pulmonary capillary blood flow nor the content of carbon dioxide in the venous blood of the patient (C_vCO_2) changes substantially during the rebreathing process. The partial pressure of carbon dioxide in blood may be converted to the content of carbon dioxide in blood by means of a carbon dioxide dissociation curve, where the change in the carbon dioxide content of the blood ($C_vCO_2 - C_aCO_2$) is equal to the slope (s) of the carbon dioxide dissociation curve multiplied by the measured change in end-tidal carbon dioxide ($P_{et}CO_2$) as effected by a change in effective ventilation, such as rebreathing.

In partial rebreathing, the patient inhales a mixture of "fresh" gases and gases exhaled during the previous breath. Thus, the patient does not inhale a volume of carbon dioxide as large as the volume of carbon dioxide that would be inhaled during a total rebreathing process. Conventional partial rebreathing processes typically employ a differential form of the carbon dioxide Fick equation to determine the pulmonary capillary blood flow or cardiac output of the patient, which do not require knowledge of the carbon dioxide content of the mixed venous blood. This differential form of the carbon dioxide Fick equation considers measurements of carbon dioxide elimination, C_vCO_2 , and the content of carbon dioxide in the alveolar blood of the patient (P_{ACO_2}) during both normal breathing and the rebreathing process as follows:

$$Q_{pctjBD} = \frac{V_{CO_{2B}} - V_{CO_{2D}}}{(CvCO_{2B} - CvCO_{2D}) - (CaCO_{2B} - CaCO_{2D})} \quad (2)$$

where $V_{CO_{2B}}$ and $V_{CO_{2D}}$ are the carbon dioxide production of the patient before rebreathing and during the rebreathing process, respectively, $CvCO_{2B}$ and $CvCO_{2D}$ are the content of CO_2 of the venous blood of the patient before rebreathing and during the rebreathing process, respectively, and $CaCO_{2B}$ and $CaCO_{2D}$ are the content of CO_2 in the arterial blood of the patient before rebreathing and during rebreathing, respectively.

Again, with a carbon dioxide dissociation curve, the measured $PetCO_2$ can be used to determine the change in content of carbon dioxide in the blood before and during the rebreathing process. Accordingly, the following equation can be used to determine pulmonary capillary blood flow or cardiac output when partial rebreathing is conducted:

$$Q = \Delta V_{CO_2} / s \Delta PetCO_2 \quad (3)$$

Alternative differential Fick methods of measuring pulmonary capillary blood flow or cardiac output have also been employed. Such differential Fick methods typically include a brief change of $PetCO_2$ and V_{CO_2} in response to a change in effective ventilation. This brief change can be accomplished by adjusting the respiratory rate, inspiratory and/or expiratory times, or tidal volume. A brief change in effective ventilation may also be effected by adding CO_2 , either directly or by rebreathing. An exemplary differential Fick method that has been employed, which is disclosed in Gedeon, A. et al. in 18 *Med. & Biol. Eng. & Comput.* 411-418 (1980), employs a period of increased ventilation followed immediately by a period of decreased ventilation.

The carbon dioxide elimination of a patient is typically measured over the course of a breath by the following, or an equivalent, equation:

$$V_{CO_2} = \int_{breath} V \times f_{CO_2} dt \quad (4)$$

where V is the measured respiratory flow and f_{CO_2} is the substantially simultaneously detected carbon dioxide signal, or fraction of the respiratory gases that comprises carbon dioxide or "carbon dioxide fraction".

Due to the measured respiratory constituents upon which V_{CO_2} and $PetCO_2$ calculations are made, V_{CO_2} typically responds to rebreathing about one breath before $PetCO_2$ for the same breath. Accordingly, a V_{CO_2} signal may lead a $PetCO_2$ signal by about one breath. Thus, at a particular point in time, the V_{CO_2} and $PetCO_2$ signals do not correspond to one another. As these values are often used to noninvasively determine pulmonary capillary blood flow or cardiac output, the lack of correspondence between these values may lead to inaccuracies in the pulmonary capillary blood flow or cardiac output determination.

In addition, measurements that are taken during spurious breaths, or breaths which do not provide information relevant to pulmonary capillary blood flow or cardiac output, may act as noise that introduces inaccuracy into the noninvasive pulmonary capillary blood flow or cardiac output determination.

When equation (4) is employed to calculate the carbon dioxide elimination of the patient from the respiratory flow and carbon dioxide fraction measurements over an entire breath, such miscorrelation or noise-induced inaccuracies in either the expiratory flow, the inspiratory flow, or both may cause inaccuracies in the carbon dioxide elimination determination or inconsistencies between carbon dioxide elimination determinations.

Accordingly, there is a need for a method of accurately, noninvasively calculating pulmonary capillary blood flow and cardiac output.

SUMMARY OF THE INVENTION

The present invention includes a method for noninvasively measuring pulmonary capillary blood flow and cardiac output. The present invention includes the use of known rebreathing techniques to substantially noninvasively obtain carbon dioxide elimination (V_{CO_2}) and partial pressure of end-tidal carbon dioxide ($PetCO_2$) measurements of a patient's breathing. These measurements may then be used to calculate pulmonary capillary blood flow or cardiac output of the patient by employing the following equation:

$$Q = \frac{\Delta V_{CO_2}}{\Delta CaCO_2} = \frac{\Delta V_{CO_2}}{s \Delta PetCO_2} \quad (5)$$

where s is the slope of a standard carbon dioxide (CO_2) dissociation curve, ΔV_{CO_2} is the change in the carbon dioxide elimination of the patient due to a change in effective ventilation, such as that caused by rebreathing, and $\Delta CaCO_2$ and $\Delta PetCO_2$ are the change in the content of carbon dioxide in the arterial blood of the patient and the change in the end-tidal partial pressure of carbon dioxide of the patient, respectively, due to the same change in effective ventilation. Alternatively, a standard carbon dioxide dissociation curve can be used to determine $\Delta CaCO_2$ on the basis of the measured $\Delta PetCO_2$.

As an alternative to the use of the above equations to determine pulmonary capillary blood flow or cardiac output, the substantially noninvasive V_{CO_2} and $CaCO_2$ measurements can be related to each other in a linear fashion. This can be visually diagramed by plotting the V_{CO_2} and $CaCO_2$ measurements against one another on a two-dimensional (X-Y) line graph. The negative slope ($-1 \times m$) of the best-fit line through the data is approximately equal to the pulmonary capillary blood flow. The appropriate location and orientation of such a best-fit line may be calculated by linear regression or least squares. Depending on the correlation between the calculated best-fit line and the measured data, it may also be desirable to modify the data to provide a best-fit line that closely corresponds to the data.

In one embodiment of the method of the present invention, the data can be modified by use of a known filter, such as a low-pass filter or a high-pass filter. Either digital or analog filters may be used. Either linear or nonlinear (e.g., median) filters may be used. By way of example, and not to limit the scope of the present invention, a low-pass filter may be applied to the measured V_{CO_2} signal. As another example, a high-pass filter may be applied to the measured $CaCO_2$ signal. Preferably, the filter and filter coefficient that are selected maximize the correlation between the measured V_{CO_2} and $CaCO_2$ signals.

In another embodiment of the method of the present invention, the data points can be modified by clustering. That is, the data points that are grouped closest to other data points are assumed to most accurately represent the true V_{CO_2} and $CaCO_2$ of the patient. For example, the measured data with at least a predetermined number of close, or similar (e.g., within a specified threshold), data points is retained, while measured data with less than the predetermined number of close data points is discarded. The retained data points are assumed to be located on or near the best-fit line. In clustering, only these closely grouped sets of data points are considered in recalculating the best-fit line for the

data and, thus, the negative slope (i.e., $-1 \times m$) of the best-fit line to determine the pulmonary capillary blood flow or cardiac output of the patient.

Another embodiment of the method of the present invention includes modifying the data points that are most likely to be closest to an accurately placed and oriented best-fit line. Each data point, which has a carbon dioxide elimination component (e.g., a y-ordinate component) and a component based on an indicator of carbon dioxide content (e.g., an x-ordinate component), is evaluated on the basis of a predetermined minimum expected pulmonary capillary blood flow and a predetermined maximum pulmonary capillary blood flow. Lines, or the equations therefor, for both minimum expected and maximum expected pulmonary capillary blood flows are located so as to intersect at each data point. Then, the number of the other data points that are located between the two pulmonary capillary blood flow lines or equations is determined for each data point. Only those data points with a threshold number of other data points between the two intersecting lines are used in the determination of the location and orientation of the best-fit line through the data.

Of course, any combination of methods of modifying data may be used to accurately determine the slope of the best-fit line through the measured V_{CO_2} and $P_{et}CO_2$ data and, thus, to determine the pulmonary capillary blood flow or cardiac output of a patient.

The best-fit line through carbon dioxide elimination and carbon dioxide content data may also be used to determine the mixed venous carbon dioxide content of the patient when partial rebreathing techniques are employed to obtain the data. As the mixed venous carbon dioxide content is assumed to equal the carbon dioxide content of the patient's blood when carbon dioxide elimination ceases (which does not occur during partial rebreathing), a best-fit line obtained by use of partial rebreathing techniques can be used to noninvasively determine carbon dioxide content and, thus, mixed venous carbon dioxide content when carbon dioxide elimination is set at zero.

Other features and advantages of the present invention will become apparent to those of ordinary skill in the art through a consideration of the ensuing description, the accompanying drawings, and the appended claims.

BRIEF DESCRIPTION OF THE DRAWINGS

FIG. 1 is a schematic representation of an exemplary rebreathing circuit that may be employed with the methods of the present invention;

FIG. 2 is a schematic representation which illustrates the componentry that may be utilized to measure respiratory profile parameters that are employed in the methods of the present invention;

FIG. 3A illustrates an idealized, bidirectional rebreathing cycle with V_{CO_2} values for different breaths depicted as diamonds and $P_{et}CO_2$ values for various breaths shown as squares;

FIG. 3B is a two-dimensional plot illustrating the use of a known, bidirectional rebreathing process to obtain three V_{CO_2} values and three values representative of the carbon dioxide content of the blood of a patient before, during, and after rebreathing; these three values have been used to substantially noninvasively determine the pulmonary capillary blood flow or cardiac output of the patient;

FIG. 3C is a two-dimensional plot of a number of V_{CO_2} values against the same number of carbon dioxide content values obtained over a single bidirectional rebreathing cycle;

FIG. 3D is an exemplary two-dimensional plot depicting V_{CO_2} and carbon dioxide content values from the same rebreathing cycle as that shown in FIG. 3C and modified in accordance with the method of the present invention;

FIGS. 4A and 4B are two-dimensional plots illustrating an embodiment of a method for modifying data to obtain an accurate best-fit line therethrough in accordance with teachings of the present invention;

FIG. 5 is a two-dimensional line graph illustrating a typical plot of V_{CO_2} on the y-axis and $CaCO_2$ on the x-axis; and

FIG. 6 is a two-dimensional line graph illustrating a plot of V_{CO_2} on the y-axis and $CaCO_2$ on the x-axis after the V_{CO_2} and $CaCO_2$ data have been modified in accordance with teachings of the present invention.

DETAILED DESCRIPTION OF THE INVENTION

The present invention includes use of the Fick equation to calculate pulmonary capillary blood flow or cardiac output as the ratio of a change in carbon dioxide elimination, or V_{CO_2} , to a change in the content of carbon dioxide, or $CaCO_2$, in the arterial blood of a patient:

$$Q = \frac{\Delta V_{CO_2}}{\Delta CaCO_2} \quad (6)$$

$CaCO_2$, or the content of carbon dioxide in the arterial blood of a patient, can be noninvasively estimated by determining the $P_{et}CO_2$, or partial pressure of carbon dioxide in the end-tidal respiration of a patient, and converting $P_{et}CO_2$ to $CaCO_2$ by use of a standard carbon dioxide dissociation curve, as is known in the art, as follows:

$$\Delta CaCO_2 = s \Delta P_{et}CO_2 \quad (7)$$

where s is the slope of the carbon dioxide dissociation curve and $\Delta P_{et}CO_2$ is a change in the end-tidal partial pressure of carbon dioxide of a patient effected by a change in ventilation. Thus, pulmonary capillary blood flow or cardiac output can also be calculated as follows:

$$Q = \Delta V_{CO_2} / s \Delta P_{et}CO_2 \quad (8)$$

Other indicators of the carbon dioxide content in the blood of a patient, such as pCO_2 , may be used in place of $P_{et}CO_2$ or $CaCO_2$ to determine the pulmonary capillary blood flow or cardiac output of a patient.

V_{CO_2} and $P_{et}CO_2$, $CaCO_2$, pCO_2 , or other indicators of the carbon dioxide content in the blood of a patient can be calculated or determined on the basis of substantially noninvasively obtained respiratory flow and respiratory carbon dioxide pressure data.

FIG. 2 schematically illustrates an exemplary method of substantially noninvasively monitoring the respiration of a patient and of measuring the flow rates and carbon dioxide concentration of gas mixtures that are inhaled and exhaled by a patient 10 over the course of the patient's breathing, such as during normal respiration or during known rebreathing techniques. A flow sensor 12 of a known type, such as the differential-pressure type respiratory flow sensors manufactured by Novamatrix Medical Systems Inc. ("Novamatrix") of Wallingford, Conn. (e.g., the Pediatric/Adult Flow Sensor (Catalog No. 6717) or the Neonatal Flow Sensor (Catalog No. 6718)), which may be operatively attached to a ventilation apparatus (not shown), as well as respiratory flow sensors based on other operating principles

and manufactured or marketed by others, may be employed to measure the flow rates of the breathing of patient 10.

A carbon dioxide sensor 14, such as the CAPNOSTAT® carbon dioxide sensor and a complementary airway adapter (e.g., the Pediatric/Adult Single Patient Use Airway Adapter (Catalog No. 6063), the Pediatric/Adult Reusable Airway Adapter (Catalog No. 7007), or the Neonatal/Pediatric Reusable Airway Adapter (Catalog No. 7053)), which are manufactured by Novamatrix, as well as main stream and side stream carbon dioxide sensors manufactured or marketed by others, may be employed to measure the carbon dioxide concentration of gas mixtures that are inhaled and exhaled by patient 10.

Flow sensor 12 and carbon dioxide sensor 14 are connected to a flow monitor 16 and a carbon dioxide monitor 18, respectively, each of which may be operatively associated with a computer 20 so that data from the flow and carbon dioxide monitors 16 and 18 representative of the signals from each of flow sensor 12 and carbon dioxide sensor 14 may be detected by computer 20 and processed according to programming (e.g., by software) thereof. Preferably, raw flow and carbon dioxide signals from the flow monitor and carbon dioxide sensor are filtered to remove any significant artifacts. As respiratory flow and carbon dioxide pressure measurements are made, the respiratory flow and carbon dioxide pressure data may be stored by computer 20.

Each breath, or breathing cycle, of patient 10 may be delineated as known in the art, such as by continuously monitoring the flow rate of the breathing of patient 10.

As use of the Fick equation to calculate pulmonary capillary blood flow or cardiac output requires that a change in V_{CO_2} and $CaCO_2$, $PetCO_2$, pCO_2 or another indicator of the carbon dioxide content in the blood of a patient be known, a change in effective ventilation is required. By way of example, and not to limit the scope of the present invention, rebreathing techniques, such as by use of a dead space 70 such as that provided by the rebreathing circuit illustrated in FIG. 1, may be employed to cause a change in effective ventilation. FIG. 3A illustrates the changes that may occur when a bidirectional rebreathing process, such as that disclosed in U.S. patent application Ser. No. 09/150,136, filed Sep. 9, 1998, and assigned to the same assignee as the present invention, is used to effect a change in effective ventilation. The graph of FIG. 3A illustrates the typical changes in the V_{CO_2} (shown as diamonds) and carbon dioxide content measurements (e.g., $PetCO_2$, shown as squares) that may occur between the baseline breathing (i.e., before rebreathing), during rebreathing, and the stabilization (i.e., after rebreathing) periods of an idealized (i.e., without noise) bidirectional rebreathing cycle. During rebreathing, V_{CO_2} changes from a baseline value (e.g., about 200 ml/min) to a during rebreathing plateau (e.g., of about 100 ml/min.) within about 3 or 4 breaths, whereas carbon dioxide content may take longer to change from a baseline value (e.g., 38 mmHg) to a plateau (e.g., about 35 mmHg).

FIG. 3B is a two-dimensional plot illustrating that one value, the plateau value, from each of the before, during, and after rebreathing phases of a bidirectional rebreathing process, such as that illustrated in FIG. 3A, was used to estimate pulmonary capillary blood flow or cardiac output. By way of contrast, in a method of determining pulmonary capillary blood flow or cardiac output incorporating teachings of the present invention, V_{CO_2} and carbon dioxide content data are continually measured, providing a plot such as that shown in FIG. 3C, with data at 100 being based on before rebreathing measurements, data along arrow 102 being based on during rebreathing measurements, and data

along arrow 104 being based on after rebreathing measurements. These data may be obtained by use of a single rebreathing cycle, over the course of a number of rebreathing cycles, at one or more discrete time intervals, or on a breath-by-breath basis, where data is continually measured, calculated, and analyzed in accordance with the method of the invention so as to continually update or monitor the pulmonary capillary blood flow or cardiac output of a patient.

When rebreathing or other known techniques are used to cause a change in effective ventilation so as to facilitate the substantially noninvasive determination of pulmonary capillary blood flow or cardiac output, respiratory flow and carbon dioxide pressure data are obtained during at least the before, during, and after stages of rebreathing. Total or partial rebreathing processes may be used in the method of the present invention. These respiratory flow and carbon dioxide pressure data are then used, as known in the art, to calculate V_{CO_2} and $PetCO_2$, as well as the changes in V_{CO_2} and $PetCO_2$ that occur with the change in effective ventilation.

The calculated V_{CO_2} and $PetCO_2$ data are then used to determine the pulmonary capillary blood flow or cardiac output of the patient, such as by use of the Fick equations presented above.

As an alternative, the pulmonary capillary blood flow or cardiac output of a patient can be determined over the course of a plurality of breaths by expressing the calculated V_{CO_2} data and $CaCO_2$ data or data of another indicator of the content of carbon dioxide in the blood of a patient, such as $PetCO_2$ or pCO_2 , in two dimensions, such as on a two-dimensional (X-Y) line graph, with V_{CO_2} data points being measured on the y-axis and $PetCO_2$ data points being measured on the x-axis, then identifying a line that best fits the data, which is also referred to herein as a best-fit line.

For example, the equation for the best-fit line is:

$$y=mx+b \quad (9)$$

or

$$m = \frac{y-b}{x}, \quad (10)$$

where y is the y-axis coordinate of a data point, x is the x-axis coordinate of the same data point, m is the slope of the line, and b is the offset value for the line. If V_{CO_2} is measured on the y-axis and $CaCO_2$ is measured on the x-axis, then

$$m = \frac{V_{CO_2} - b}{CaCO_2}. \quad (11)$$

The negative slope (i.e., $-1 \times m$) of the best-fit line through the V_{CO_2} - $CaCO_2$ data would be equal to the pulmonary capillary blood flow or cardiac output of the patient:

$$-m=Q. \quad (12)$$

The best-fit line for the V_{CO_2} and $CaCO_2$ data is preferably determined by use of known linear regression techniques or any other known methodology for determining the relationship between two variables. The method of linear regression provides an accurate pulmonary capillary blood flow or cardiac output value based on a large number of V_{CO_2} and $CaCO_2$ data obtained over the course of one or more changes in effective ventilation. When linear regres-

sion is used, the slope (m) of the best-fit line for the data is calculated as follows:

$$m=L_{xy}/L_{xx} \quad (13)$$

and the offset (b) of the line is calculated by the following equation:

$$b=\Sigma y/n-m\Sigma x/n, \quad (14)$$

where

$$L_{xx}=\Sigma x^2-(\Sigma x)^2/n, \quad (15)$$

$$L_{yy}=\Sigma y^2-(\Sigma y)^2/n, \quad (16)$$

$$L_{xy}=\Sigma xy-(\Sigma x\Sigma y)/n, \quad (17)$$

and where n is the number of data points in the plot, Σx is the sum of all x-coordinate (i.e., CaCO_2 content) values, Σy is the sum of all y-coordinate (i.e., VCO_2) values, Σx^2 is the sum of the square of all x-coordinate values, Σy^2 is the sum of the square of all y-coordinate values, and Σxy is the sum all paired x- and y-coordinate values multiplied by each other.

When linear regression is used to determine the location and orientation of a best-fit line, a correlation coefficient (r) that quantifies the accuracy with which the best-fit line correlates to the VCO_2 and CaCO_2 data can also be calculated as follows:

$$r=(L_{xy}\times L_{xy})/(L_{yy}\times L_{xx}). \quad (18)$$

Alternatively, any other measure of the quality of fit that quantifies the accuracy with which the best-fit line correlates to the VCO_2 and CaCO_2 data may be used.

Correlation coefficients range from 0 to 1.0, where a correlation coefficient of 0 indicates that no linear correlation exists between the x-ordinate and the y-ordinate data and a correlation coefficient of 1.0 indicates that the x-ordinate and y-ordinate data are perfectly linearly correlated (i.e., all of the VCO_2 - CaCO_2 data points are located on the same straight line).

The VCO_2 - CaCO_2 data points measured before and during rebreathing, however, are rarely located on the same straight line. One reason for this is that, during rebreathing maneuvers, the VCO_2 signal typically leads the PetCO_2 signal and, thus, the CaCO_2 by about one breath. In addition, VCO_2 is calculated on the basis of signal components that have higher frequencies than do the PetCO_2 signal. As a result, when the VCO_2 and CaCO_2 measurements calculated over a period of time are plotted against one another on a two-dimensional (X-Y) line graph, the result typically appears as an arc or a loop, as shown in FIGS. 3C and 5, rather than as a straight line, depending on the amount of data calculated and the duration of rebreathing. Moreover, VCO_2 and CaCO_2 measurements may be calculated on the basis of respiratory flow and carbon dioxide pressure data obtained during spurious breaths. Such data do not relate to the pulmonary capillary blood flow or cardiac output measurement. VCO_2 and CaCO_2 calculations that are based upon such spurious data act as noise that may result in miscalculation of a best-fit line through the calculated VCO_2 and CaCO_2 data. As a result, the correlation coefficient of a best-fit line to the data is typically much less than 1.0.

The measured respiratory flow and carbon dioxide pressure data or the calculated VCO_2 and CaCO_2 data can be modified to increase the correlation coefficient between the VCO_2 and CaCO_2 data and the best-fit line therefor. Preferably, a linear transform is used to increase the corre-

lation coefficient. A linear transform may be used to delay the calculation of a VCO_2 data point to accurately coincide therewith a CaCO_2 data point based on measurements taken during the same breath. The measured or calculated data may also be filtered by use of a linear transform.

In one embodiment of a method for increasing the correlation coefficient between the VCO_2 and CaCO_2 data and the best-fit line therefor, a filter is applied to the calculated VCO_2 or CaCO_2 data. Known analog or digital low-pass, high-pass, or band pass filters, including adaptive filters, may be employed. Linear or nonlinear filters may be employed. Preferably, a first order (single pole) infinite impulse response (IIR) digital filter is employed to filter the VCO_2 calculations in a manner that improves the correlation between the VCO_2 calculation and the lagging $\text{PetCO}_2/\text{CaCO}_2$ calculation. The equation for such a filter is:

$$\text{VCO}_2[n]=\alpha\times\text{VCO}_2[n-1]+(1-\alpha)\times\text{VCO}_2[n] \quad (19)$$

where $\text{VCO}_2[n]$ is the most recently calculated, unfiltered VCO_2 data point, $\text{VCO}_2[n-1]$ is the previous, filtered VCO_2 data point, $\text{VCO}_2'[n]$ is the new "filtered" value based on $\text{VCO}_2[n]$ and obtained by use of the filter, and α is the filter coefficient. The filter coefficient, α , has a range of 0 to 1.0. The greater the value of α , the more profoundly the most recently calculated data point is filtered and, conversely, the lower α values cause the most recently calculated data points to be filtered to a lesser degree. When α is equal to zero, the most recently calculated data point is not filtered.

Due to anatomical and physiological differences between different patients, different patients have differing optimal filter coefficients, α . In addition, as anatomical and physiological changes may occur in a patient over time, the optimum filter coefficients, α , to be used in filtering the VCO_2 or CaCO_2 values calculated from the patient's breathing may also vary over time. Accordingly, the selection of an optimal filter coefficient, α , is also within the scope of the present invention. Any known optimization method or search algorithm may be employed to select the optimal filter coefficient, α .

As an example of the way in which an optimal filter coefficient may be selected, α is first set to a default value (e.g., 0.85) and the calculated VCO_2 or CaCO_2 values are filtered on the basis of the default filter coefficient, α . The linear regression is then performed to obtain a best-fit line. If the correlation coefficient of best-fit line calculated with the just-filtered data is less than the correlation coefficient of the immediately preceding best-fit line, which was calculated with unfiltered data or with a prior filter coefficient, then a predetermined α adjustment value (e.g., 0.01) is changed by multiplying the α adjustment value by -1 and by modifying the filter coefficient by adding the modified α adjustment value thereto. Otherwise, the filter coefficient, α is modified by adding the unmodified α adjustment value thereto. The process of filtering the data based on a modified filter coefficient, obtaining a best-fit line for the data, comparing the correlation coefficient of the best-fit line to the correlation coefficient of the previous best-fit line, and adjusting the filter coefficient accordingly is then repeated a predetermined number of times (e.g., 50 times). The best-fit line with the greatest correlation coefficient, based on the unfiltered data and each set of filtered data, is selected to calculate the pulmonary capillary blood flow or cardiac output of the patient. When filtering is used, the VCO_2 - CaCO_2 plot preferably narrows, as depicted in FIGS. 3D and 6, to thereby increase the accuracy with which the location and orientation of a best-fit line can be established and, thus, to increase the accuracy of a pulmonary capillary blood flow or cardiac output determination based on the data.

Another embodiment of a method for increasing the correlation coefficient between the V_{CO_2} and $CaCO_2$ data and the best-fit line therefor, which is referred to herein as "clustering", includes the selection of data points that are grouped closely together. That is, the data points that are selected include those data points having a number of other data points within a predetermined range thereof. Data points that are not clustered are probably inaccurate or based on measurements taken during spurious breaths. As an accurate best-fit line through the data would likely be based on the clustered data, the data points that are not located in a cluster are not used in calculating the location and orientation of a best-fit line for the data.

Clustering of the data points may include normalization or transformation of the data such that ranges of the x-coordinate data (e.g., the $CaCO_2$ data) and the y-coordinate data (e.g., the V_{CO_2} data) are substantially the same. Without such normalization, the data group (e.g., the V_{CO_2} data or the $CaCO_2$ data) with the highest range would dominate; the other data group would be less significant.

An exemplary manner in which the data may be normalized includes use of the following normalization:

$$x=(x-\bar{x})/\sigma_x \quad (20)$$

where:

x is the raw value, \bar{x} is the mean value of all x-axis (e.g., $CaCO_2$) data in the plot, and σ_x is the standard deviation of all x-axis data in the plot. This normalization is applied to all x-axis values. A similar normalization scheme is applied to all of the y-axis values.

The normalized data may then be clustered by searching for a predetermined number (e.g., 5) of the closest data points (e.g., V_{CO_2} or $CaCO_2$ data points) to each of the data points in a group. The differences between the analyzed data point and each of the predetermined number of closest data points are then added together and compared to a predetermined threshold. If the sum of the differences exceeds the predetermined threshold, the analyzed data point is discarded. Of course, the use of other clustering techniques to identify the most accurate data and to disregard probable inaccurate data is also within the scope of the present invention.

Once clustering has been performed, the inverse of the normalization is calculated, or the normalization is undone, to provide an accurate determination of pulmonary capillary blood flow or cardiac output. An example of the manner in which the inverse of the normalization may be calculated includes use of the following equation:

$$x=x\sigma_x+\bar{x} \quad (21)$$

This inverse of the normalization is applied to all of the clustered x-axis (e.g., $CaCO_2$) values. A similar inverse normalization scheme is applied to all of the clustered y-axis data.

Clustering is one of many known techniques for determining outliers. Other known techniques for determining outliers may also be used in the method of the present invention.

Alternatively, or in addition to disregarding probable inaccurate data points, in order to enhance the accuracy of the data, clustering can be used to add synthetic data points. Synthetic data points may be added to increase the correlation coefficient of the best-fit line to the data points on which the best-fit line is based.

Another embodiment of the method for modifying data that incorporates teachings of the present invention is

depicted in FIGS. 4A and 4B. As with the filtering and clustering embodiments described previously herein, the present embodiment includes selection of data points that are most likely to facilitate an accurate determination of the location and orientation of a best-fit line and, thus, of the pulmonary capillary blood flow or cardiac output of a patient. This embodiment of the method for modifying data includes iteratively examining data points and the distribution of the remaining data points relative to the two lines representing the range of possible PCBF measurements.

As shown in FIGS. 4A and 4B, a line or the equation for a line 110 representing a minimum expected pulmonary capillary blood flow (i.e., $-m_{line}=PCBF_{min}$) and a line or the equation for a line 120 representing a maximum expected pulmonary capillary blood flow (i.e., $-m_{line120}=PCBF_{max}$) are positioned to intersect at a data point 130. For example, when the x-ordinate is based on $CaCO_2$, line 110 may have a slope of -0.5 , which represents a minimum expected pulmonary capillary blood flow of 0.5 L/min, and line 120 may have a slope of -20 , which represents a maximum pulmonary capillary blood flow of 20 L/min. Of course, the use of other pulmonary capillary blood flow values for lines 110 and 120 is also within the scope of the present invention.

Next, the number of other data points 130 located between lines 110 and 120 is determined. If the number of data points 130 between lines 110 and 120 is equal to or exceeds a threshold number, the analyzed data point 130 is retained for a subsequent determination of the location and orientation of a best-fit line through the data. Otherwise, the analyzed data point 130 is discarded. The threshold number of data points that must be located between line 110 and line 120 for an analyzed data point to be retained may be a predetermined value or determined by other means. As an example, the threshold number may be set to the median number of data points that are located between line 110 and line 120 when each data point 130 of a set of data points 130 has been evaluated in accordance with the present embodiment of the method for modifying data. This process is repeated until each data point 130 in a set of data points 130 has been so evaluated. FIG. 4A depicts use of the present embodiment of the data modification method on a data point 130 that will be retained, while FIG. 4B illustrates use of the present embodiment of the data modification method on another data point 130' that will not be retained.

FIGS. 3C and 3D and FIGS. 5 and 6 illustrate the effect of modifying data in accordance with teachings of the present invention to increase the accuracy with which the location and orientation of a best-fit line through the data may be determined. FIG. 5 illustrates a typical V_{CO_2} vs. $CaCO_2$ plot without such modification, where the plot appears as a loop. By way of contrast, FIG. 6 illustrates the closeness of the data when one or more of the embodiments of the method of the present invention are used to modify the data. FIGS. 3C and 3D illustrate plots of V_{CO_2} and $PetCO_2$ data before and after modification in accordance with the present invention, respectively. The increased closeness of the data points makes it possible to determine the orientation and location of a best-fit line therethrough with increased accuracy.

Once all of the data points have been examined, the location and orientation for the best-fit line through the remaining, clustered data are determined. Again, linear regression is preferably used to determine the location and orientation of the best-fit line. The negative slope (i.e., $-1 \times m$) of the best-fit line provides a pulmonary capillary blood flow measurement, which may then be used to determine cardiac output. A correlation coefficient can then be

calculated, as previously disclosed herein, to indicate the quality of the data used to determine pulmonary capillary blood flow or cardiac output. The correlation coefficient or a quality measure based thereon may then be communicated to the user (e.g., a doctor, nurse, or respiratory technician) or used to weight the resulting pulmonary capillary blood flow or cardiac output value in an output weighted average value.

One or a combination of the embodiments of the method for modifying data in accordance with the present invention may be performed on the measured or calculated data to increase the accuracy with which a best-fit line through the data or the pulmonary capillary blood flow or cardiac output of a patient can be determined.

As an example of the use of filtering and clustering together, the calculated VCO_2 data are grouped together as the y-axis data of a two-dimensional line graph and the calculated $CaCO_2$ data points are grouped together as x-axis data points. The data points in at least one of the groups are filtered to determine a best-fit line for the data having an optimum correlation coefficient. The data are also clustered, either before or after filtering, to further improve the correlation coefficient of the best-fit line to the calculated VCO_2 and $CaCO_2$ data. The remaining data is then used to determine (e.g., by linear regression) a best-fit line therefor, as well as a correlation coefficient for the best-fit line. The slope of the best-fit line is then calculated and used to determine pulmonary capillary blood flow or cardiac output. The correlation coefficient may also be used to indicate the reliability of the pulmonary capillary blood flow or cardiac output determination or to impart a specific weight to the pulmonary capillary blood flow or cardiac output determination in a weighted average thereof.

Once the location and orientation of an accurate best-fit line for the data has been determined, as disclosed previously herein, the pulmonary capillary blood flow of the patient can be calculated as the negative of the slope of the best-fit line. In addition, cardiac output can then also be determined by adding the pulmonary capillary blood flow of the patient to the intrapulmonary shunt flow of the patient, which can be determined by known processes.

In addition, the best-fit line can be used to estimate mixed venous carbon dioxide content of the patient. Conventionally, total rebreathing techniques have been required to substantially noninvasively measure mixed venous carbon dioxide content. When carbon dioxide elimination eventually ceases during total rebreathing, the partial pressure of carbon dioxide measured at the mouth of a patient may represent the mixed venous carbon dioxide content of the patient. When partial rebreathing techniques are used, the carbon dioxide elimination of the patient is reduced to levels lower than baseline, but is not reduced to zero. By employing teachings of the present invention to determine the best-fit line through data obtained by use of partial rebreathing techniques, the best-fit line can be extended to a point where carbon dioxide elimination would be equal to zero or effectively zero and thereby to determine the carbon dioxide content, or mixed venous carbon dioxide content, of the patient's blood at that point. Equation (11), which is a derivative of the equation for the best-fit line, can be rearranged in terms of carbon dioxide elimination as follows:

$$V_{CO_2} = m \times CaCO_2 + b. \quad (22)$$

When carbon dioxide elimination ceases, VCO_2 is equal to zero and equation (22) becomes:

$$0 = m \times CvCO_2 + b, \quad (23)$$

where $CvCO_2$ is the mixed venous carbon dioxide content, which can be rearranged as follows:

$$CvCO_2 = -b/m. \quad (24)$$

Accordingly, the present invention also includes a method for substantially noninvasively determining mixed venous carbon dioxide content when partial rebreathing techniques are employed.

Although the foregoing description contains many specifics, these should not be construed as limiting the scope of the present invention, but merely as providing illustrations of some of the presently preferred embodiments. Similarly, other embodiments of the invention may be devised which do not depart from the spirit or scope of the present invention. Features from different embodiments may be employed in combination. The scope of the invention is, therefore, indicated and limited only by the appended claims and their legal equivalents, rather than by the foregoing description. All additions, deletions and modifications to the invention as disclosed herein which fall within the meaning and scope of the claims are to be embraced thereby.

What is claimed is:

1. A method for noninvasively determining at least a pulmonary capillary blood flow of a patient, comprising:

determining a plurality of data comprising carbon dioxide elimination data and data of an indicator of carbon dioxide content in blood of the patient;

plotting said carbon dioxide elimination data against said data of said indicator of carbon dioxide content;

determining a best-fit line through said plotted data; and calculating at least the pulmonary capillary blood flow based on a slope of said best-fit line.

2. The method of claim 1, wherein said plotting comprises plotting said carbon dioxide elimination data against corresponding $CaCO_2$ data.

3. The method of claim 2, wherein said calculating at least the pulmonary capillary blood flow comprises multiplying said slope by -1 .

4. The method of claim 1, wherein said plotting comprises plotting said carbon dioxide elimination data against corresponding data of partial pressure of carbon dioxide in end tidal respiration of the patient.

5. The method of claim 1, wherein said plotting comprises measuring said carbon dioxide elimination data on a y-axis of a two-dimensional line graph and measuring said data of said indicator of carbon dioxide content on an x-axis of said two-dimensional line graph.

6. The method of claim 1, wherein said determining said best-fit line comprises use of linear regression.

7. The method of claim 1, further comprising determining a correlation coefficient indicative of a correlation between said carbon dioxide elimination data and said data of said indicator of carbon dioxide content.

8. The method of claim 1, further comprising filtering at least one of said carbon dioxide elimination data and said data of said indicator of carbon dioxide content.

9. The method of claim 8, wherein said filtering comprises employing a low-pass filter, a high-pass filter, or a band pass filter.

10. The method of claim 8, wherein said filtering comprises employing a linear or a nonlinear filter.

11. The method of claim 8, wherein said filtering comprises filtering said carbon dioxide elimination data.

12. The method of claim 11, wherein said filtering comprises employing a low-pass filter.

13. The method of claim 12, wherein said employing said low-pass filter comprises filtering said carbon dioxide elimi-

15

nation data to obtain filtered data on the basis of an infinite impulse response form.

14. The method of claim 13, wherein said filtering said carbon dioxide elimination data to obtain said filtered data on the basis of said infinite impulse response form comprises employing the equation:

$$V_{CO_2}[n]=\alpha \times V_{CO_2}[n-1]+(1-\alpha) \times V_{CO_2}[n],$$

where $V_{CO_2}[n]$ is the most recently obtained, unfiltered carbon dioxide elimination data point, $V_{CO_2}[n-1]$ is the previous, filtered carbon dioxide elimination data point, $V_{CO_2}[n]$ is the new "filtered" value based on $V_{CO_2}[n]$ and obtained by use of said low-pass filter, and α is a filter coefficient.

15. The method of claim 14, further comprising:

determining a correlation coefficient indicative of a correlation between said carbon dioxide elimination data and said data of said indicator of carbon dioxide content;

determining another best-fit line based on said filtered data;

determining another correlation coefficient between said filtered data; and

comparing said correlation coefficient and said another correlation coefficient.

16. The method of claim 15, further comprising adjusting said filter coefficient based on said comparing.

17. The method of claim 15, further comprising selecting a best-fit line with the highest correlation coefficient.

18. The method of claim 8, further comprising clustering said carbon dioxide elimination data and said data of said indicator of carbon dioxide content.

19. The method claim 1, further comprising selecting data points to use in said determining said best-fit line.

20. The method of claim 19, wherein said selecting comprises clustering said carbon dioxide elimination data and said data of said indicator of carbon dioxide content.

21. The method of claim 20, wherein said clustering is effected before said determining said best-fit line.

22. The method of claim 20, further comprising normalizing said carbon dioxide elimination data and said data of said indicator of carbon dioxide content.

23. The method of claim 22, wherein said normalizing is effected before said clustering.

24. The method of claim 22, wherein said normalizing comprises selecting substantially equal ranges for both said carbon dioxide elimination data and said data of said indicator of carbon dioxide content.

25. The method of claim 22, further comprising calculating an inverse of said normalizing following said clustering and before said determining said best-fit line.

26. The method of claim 25, wherein said calculating said inverse of said normalizing comprises setting ranges for said carbon dioxide elimination data and said data of said indicator of carbon dioxide content back to original values.

27. The method of claim 20, wherein said clustering comprises:

identifying a predetermined number of data points having values closest to an analyzed data point selected from one of said carbon dioxide elimination data and said data of said indicator of carbon dioxide content,

calculating differences between each of said predetermined number of data points and said analyzed data point;

summing said differences to obtain a sum;

16

comparing said sum to a threshold value; and disregarding said analyzed data point if said sum exceeds said threshold value.

28. The method of claim 20, further comprising filtering at least one of said carbon dioxide elimination data and said data of said indicator of carbon dioxide content.

29. The method of claim 19, wherein said selecting comprises:

intersecting a first line representing a minimum expected pulmonary capillary blood flow and a second line representing a maximum pulmonary capillary blood flow at an analyzed data point of said data points;

determining a number of others of said data points located between said first line and said second line;

comparing said number to a threshold number; and retaining said analyzed data point if said number is equal to or greater than said threshold number.

30. The method of claim 29, further comprising repeating at least said intersecting, said determining said number of others of said data points, and said comparing on at least one other data point of said data points.

31. The method of claim 29, further comprising repeating at least said intersecting, said determining said number of others of said data points, and said comparing on each of said data points.

32. The method of claim 31, further comprising determining said threshold number.

33. The method of claim 32, wherein said determining said threshold number comprises setting said threshold number equal to a median of said number of others of said data points located between said first line and said second line corresponding to each of said data points.

34. The method of claim 29, wherein said comparing comprises comparing said number to a predetermined threshold number.

35. The method of claim 29, further comprising discarding said analyzed data point if said number is less than said threshold number.

36. The method of claim 29, further comprising filtering at least one of said carbon dioxide elimination data and said data of said indicator of carbon dioxide content.

37. The method of claim 29, further comprising clustering said carbon dioxide elimination data and said data of said indicator of carbon dioxide content.

38. A method for noninvasively determining at least a pulmonary capillary blood flow of a patient, comprising:

determining a plurality of data comprising carbon dioxide elimination data and data of an indicator of carbon dioxide content in blood of the patient;

determining a slope of a best-fit line through said plurality of data; and

calculating at least the pulmonary capillary blood flow based on said slope.

39. The method of claim 38, further comprising plotting said carbon dioxide elimination data against said data of said indicator of carbon dioxide content.

40. The method of claim 39, wherein said plotting comprises plotting said carbon dioxide elimination data against $CaCO_2$ data.

41. The method of claim 40, wherein said calculating at least the pulmonary capillary blood flow comprises multiplying said slope by -1 .

42. The method of claim 39, wherein said plotting comprises plotting said carbon dioxide elimination data against corresponding data of partial pressure of carbon dioxide in end tidal respiration of the patient.

17

43. The method of claim 39, wherein said plotting comprises measuring said carbon dioxide elimination data on a y-axis of a two-dimensional line graph and measuring said data of said indicator of carbon dioxide content on the x-axis of said two-dimensional line graph.

44. The method of claim 38, wherein said determining said slope of said best-fit line comprises use of linear regression.

45. The method of claim 38, further comprising determining a correlation coefficient indicative of a correlation between said carbon dioxide elimination data and said data of said indicator of carbon dioxide content.

46. The method of claim 38, further comprising filtering at least one of said carbon dioxide elimination data and said data of said indicator of carbon dioxide content.

47. The method of claim 46, wherein said filtering comprises employing a low-pass filter, a high-pass filter, or a band pass filter.

48. The method of claim 46, where in said filtering comprises employing a linear filter or a nonlinear filter.

49. The method of claim 48, wherein said filtering comprises employing a low-pass filter.

50. The method of claim 49, wherein said employing said low-pass filter comprises filtering said carbon dioxide elimination data to obtain filtered data on the basis of an infinite impulse response form.

51. The method of claim 50, wherein said filtering said carbon dioxide elimination data to obtain filtered data on the basis of said infinite impulse response form comprises employing the equation:

$$V_{CO_2}[n]=\alpha \times V_{CO_2}[n-1]+(1-\alpha) \times V_{CO_2}[n]$$

where $V_{CO_2}[n]$ is the most recently obtained, unfiltered carbon dioxide elimination data point, $V_{CO_2}[n-1]$ is the previous, filtered carbon dioxide elimination data point, $V_{CO_2}[n]$ is the new "filtered" value based on $V_{CO_2}[n]$ and obtained by use of said low-pass filter, and α is a filter coefficient.

52. The method of claim 51, further comprising:
determining a correlation coefficient indicative of a correlation between said carbon dioxide elimination data and said data of said indicator of carbon dioxide content;

determining another best-fit line based on said filtered data;

determining another correlation coefficient between said filtered data; and

comparing said correlation coefficient and said another correlation coefficient.

53. The method of claim 52, further comprising adjusting said filter coefficient based on said comparing.

54. The method of claim 52, further comprising selecting a best-fit line with the highest correlation coefficient.

55. The method of claim 46, wherein said filtering comprises filtering said carbon dioxide elimination data.

56. The method of claim 46, further comprising clustering said carbon dioxide elimination data and said data of said indicator of carbon dioxide content.

57. The method of claim 38, further comprising selecting data to use in said determining said slope.

58. The method of claim 57, wherein said selecting comprises clustering said carbon dioxide elimination data and said data of said indicator of carbon dioxide content.

59. The method of claim 58, wherein said clustering is effected before said determining said slope of said best-fit line.

18

60. The method of claim 58, further comprising normalizing said carbon dioxide elimination data and said data of said indicator of carbon dioxide content.

61. The method of claim 60, wherein said normalizing is effected before said clustering.

62. The method of claim 60, wherein said normalizing comprises selecting substantially equal ranges for both said carbon dioxide elimination data and said data of said indicator of carbon dioxide content.

63. The method of claim 60, further comprising calculating an inverse of said normalizing following said clustering and before said determining said slope of said best-fit line.

64. The method of claim 63, wherein said calculating said inverse of said normalizing comprises setting ranges for said carbon dioxide elimination data and said data of said indicator of carbon dioxide content back to original values.

65. The method of claim 58, wherein said clustering comprises:

identifying a predetermined number of data points having values closest to an analyzed data point selected from one of said carbon dioxide elimination data and said data of said indicator of carbon dioxide content;

calculating differences between each of said predetermined number of data points and said analyzed data point;

summing said differences to obtain a sum;

comparing said sum to a threshold value; and

disregarding said analyzed data point if said sum exceeds said threshold value.

66. The method of claim 58, further comprising filtering at least one of said carbon dioxide elimination data and said data of said indicator of carbon dioxide content.

67. The method of claim 57, wherein said selecting comprises:

intersecting a first line representing a minimum expected pulmonary capillary blood flow and a second line representing a maximum pulmonary capillary blood flow at an analyzed data point of said plurality of data;

determining a number of others of said plurality of data located between said first line and said second line;

comparing said number to a threshold number; and

retaining said analyzed data point if said number is equal to or greater than said threshold number.

68. The method of claim 67, further comprising repeating at least said intersecting, said determining said number of others of said plurality of data, and said comparing on at least one other data point of said plurality of data.

69. The method of claim 67, further comprising repeating at least said intersecting, said determining said number of others of said plurality of data, and said comparing on each of said plurality of data.

70. The method of claim 69, further comprising determining said threshold number.

71. The method of claim 70, wherein said determining said threshold number comprises setting said threshold number equal to a median of said number of others of said plurality of data located between said first line and said second line corresponding to each of said plurality of data.

72. The method of claim 67, wherein said comparing comprises comparing said number to a predetermined threshold number.

73. The method of claim 67, further comprising discarding said analyzed data point if said number is less than said threshold number.

74. The method of claim 67, further comprising filtering at least one of said carbon dioxide elimination data and said data of said indicator of carbon dioxide content.

75. The method of claim 67, further comprising clustering said carbon dioxide elimination data and said data of said indicator of carbon dioxide content.

76. A method for noninvasively determining at least a pulmonary capillary blood flow of a patient, comprising:
 5 determining a plurality of data comprising carbon dioxide elimination data and data of an indicator of carbon dioxide content in blood of the patient;
 determining a correlation coefficient between said carbon dioxide elimination data and said data of said indicator of carbon dioxide content;
 10 modifying at least one of said carbon dioxide elimination data and said data of said indicator of carbon dioxide content to increase said correlation coefficient, and
 calculating at least the pulmonary capillary blood flow based on carbon dioxide elimination data and data of said indicator of carbon dioxide content providing a highest correlation coefficient.

77. The method of claim 76, wherein said determining said plurality of data comprises:

measuring a respiratory flow and a carbon dioxide pressure of respiration of the patient; and
 calculating carbon dioxide elimination and an indicator of carbon dioxide content of the blood of the patient based at least on said respiratory flow and said carbon dioxide pressure to provide said carbon dioxide elimination data and said data of said indicator of carbon dioxide content.

78. The method of claim 76, wherein said determining said data of said indicator of carbon dioxide content comprises determining CaCO_2 .

79. The method of claim 76, wherein said determining said correlation coefficient comprises employing linear regression on said carbon dioxide elimination data and said data of said indicator of carbon dioxide content.

80. The method of claim 76, wherein said modifying comprises filtering at least one of said carbon dioxide elimination data and said data of said indicator of carbon dioxide content.

81. The method of claim 80, wherein said filtering comprises employing a low-pass filter, a high-pass filter, or a band pass filter.

82. The method of claim 80, wherein said filtering comprises employing a linear filter or a nonlinear filter.

83. The method of claim 80, wherein said filtering comprises filtering said carbon dioxide elimination data.

84. The method of claim 83, wherein said filtering comprises employing a low-pass filter.

85. The method of claim 84, wherein said employing said low-pass filter comprises filtering said carbon dioxide elimination data to obtain filtered data on the basis of an infinite impulse response form.

86. The method of claim 85, wherein said filtering said carbon dioxide elimination data to obtain filtered data on the basis of said infinite impulse response form comprises employing the equation:

$$V_{\text{CO}_2}[n]=\alpha \times V_{\text{CO}_2}[n-1]+(1-\alpha) \times V_{\text{CO}_2}[n]$$

where $V_{\text{CO}_2}[n]$ is the most recently obtained, unfiltered carbon dioxide elimination data point, $V_{\text{CO}_2}[n-1]$ is the previous, filtered carbon dioxide elimination data point, $V_{\text{CO}_2}[n]$ is the new "filtered" value based on $V_{\text{CO}_2}[n]$ and obtained by use of said low-pass filter, and α is a filter coefficient.

87. The method of claim 86, further comprising:
 determining another correlation coefficient between said carbon dioxide elimination data and said data of an

indicator of carbon dioxide content based at least in part on said filtered data; and
 comparing said correlation coefficient and said another correlation coefficient.

88. The method of claim 87, further comprising adjusting said filter coefficient based on said comparing.

89. The method of claim 80, wherein said modifying further comprises clustering said carbon dioxide elimination data and said data of said indicator of carbon dioxide content.

90. The method of claim 76, wherein said modifying comprises selecting data points to use in said calculating.

91. The method of claim 89, wherein said selecting comprises clustering said carbon dioxide elimination data and said data of said indicator of carbon dioxide content.

92. The method of claim 91, wherein said clustering is effected before said calculating.

93. The method of claim 91, further comprising normalizing said carbon dioxide elimination data and said data of said indicator of carbon dioxide content.

94. The method of claim 93, wherein said normalizing is effected before said clustering.

95. The method of claim 93, wherein said normalizing comprises selecting substantially equal ranges for both said carbon dioxide elimination data and said data of said indicator of carbon dioxide content.

96. The method of claim 93, further comprising calculating an inverse of said normalizing following said clustering and before said calculating.

97. The method of claim 96, wherein said calculating said inverse of said normalizing comprises setting ranges for said carbon dioxide elimination data and said data of said indicator of carbon dioxide content back to original values.

98. The method of claim 91, wherein said clustering comprises:

identifying a predetermined number of data points having values closest to an analyzed data point selected from one of said carbon dioxide elimination data and said data of said indicator of carbon dioxide content;
 calculating differences between each of said predetermined number of data points and said analyzed data point;
 summing said differences to obtain a sum;
 comparing said sum to a threshold value; and
 disregarding said analyzed data point if said sum exceeds said threshold value.

99. The method of claim 91, further comprising filtering at least one of said carbon dioxide elimination data and said data of said indicator of carbon dioxide content.

100. The method of claim 91, wherein said selecting further comprises:

intersecting a first line representing a minimum expected pulmonary capillary blood flow and a second line representing a maximum pulmonary capillary blood flow at an analyzed data point of said plurality of data;
 determining a number of others of said plurality of data located between said first line and said second line;
 comparing said number to a threshold number; and
 retaining said analyzed data point if said number is equal to or greater than said threshold number.

101. The method of claim 100, further comprising repeating at least said intersecting, said determining said number of others of said plurality of data, and said comparing on at least one other data point of said plurality of data.

102. The method of claim 100, further comprising repeating at least said intersecting, said determining said number

21

of others of said plurality of data, and said comparing on each data point of said plurality of data.

103. The method of claim **102**, further comprising determining said threshold number.

104. The method of claim **103**, wherein said determining said threshold number comprises setting said threshold number equal to a median of said number of others of said plurality of data located between said first line and said second line corresponding to each data point of said plurality of data.

105. The method of claim **100**, wherein said comparing comprises comparing said number to a predetermined threshold number.

106. The method of claim **100**, further comprising discarding said analyzed data point if said number is less than said threshold number.

107. The method of claim **100**, further comprising filtering at least one of said carbon dioxide elimination data and said data of said indicator of carbon dioxide content.

108. The method of claim **100**, further comprising clustering said carbon dioxide elimination data and said data of said indicator of carbon dioxide content.

22

109. The method of claim **76**, wherein said calculating comprises determining a best-fit line through said plurality of data.

110. The method of claim **109**, wherein said determining said best-fit line comprises employing linear regression on said carbon dioxide elimination data and said data of said indicator of carbon dioxide content.

111. The method of claim **109**, wherein said determining said best-fit line comprises plotting said carbon dioxide elimination data against said data of said indicator of carbon dioxide content.

112. The method of claim **109**, further comprising determining a slope of said best-fit line.

113. The method of claim **112**, wherein said calculating is based on said slope.

114. The method of claim **113**, wherein said indicator of carbon dioxide content is CaCO_2 and said calculating comprises multiplying said slope by -1 .

* * * * *

UNITED STATES PATENT AND TRADEMARK OFFICE
CERTIFICATE OF CORRECTION

PATENT NO. : 6,540,689 B1
DATED : April 1, 2003
INVENTOR(S) : Joseph A. Orr and Kai Küick

Page 1 of 2

It is certified that error appears in the above-identified patent and that said Letters Patent is hereby corrected as shown below:

Title page.

Item [56] **References Cited**, "5,069,220 A", change "Caparie" to -- Casparie --

Drawings.

FIGURE 4A, change "120'" to -- 130' -- as shown below

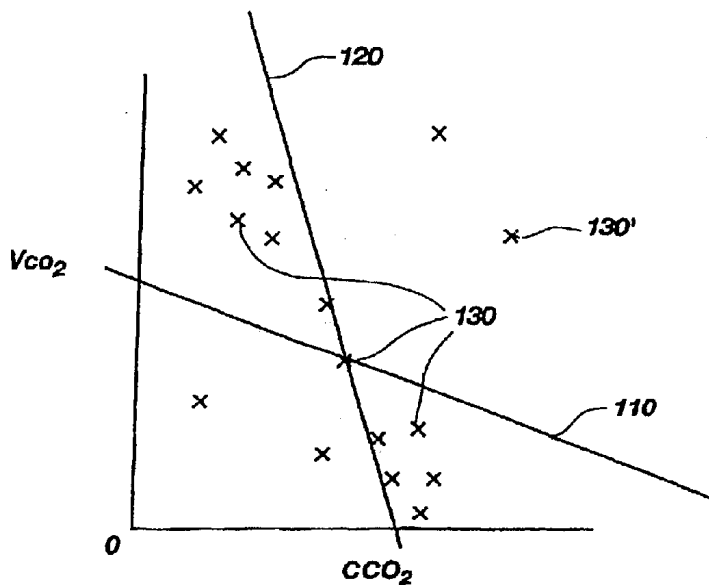

Fig. 4A

Column 1,

Line 50, change "(PACO₂)" to -- (PACO₂) --

Column 2,

Line 37, insert a space after "etCO₂" and before "is"

Line 40, change "(PACO₂)" to -- (PACO₂) --

Line 48, insert a space after "-CaCO₂" and before "is"

Line 66, change "(CACO₂)" to -- (CACO₂) -- and insert a space after "(CACO₂)"

Column 4,

Line 11, insert a space after "(PetCO₂)" and before "measurements"

Column 7,

Line 21, insert a period after "thereof"

UNITED STATES PATENT AND TRADEMARK OFFICE
CERTIFICATE OF CORRECTION

PATENT NO. : 6,540,689 B1
DATED : April 1, 2003
INVENTOR(S) : Joseph A. Orr and Kai Kück

Page 2 of 2

It is certified that error appears in the above-identified patent and that said Letters Patent is hereby corrected as shown below:

Column 9,

Line 19, insert a space after "VCO₂)" and before "values"

Column 10,

Line 52, change "a" to -- α --

Column 11,

Line 28, insert a space after "CaCO₂)" and before "data"

Line 53, insert a space after "CaCO₂)" and before "values"

Column 13,

Line 32, insert a period after "thereof"

Column 15,

Line 62, change the comma after "content" to a semicolon

Column 17,

Line 19, change "where in" to -- wherein --

Column 19,

Line 14, change the comma after "coefficient" to a semicolon

Column 20,

Line 13, change "89" to -- 90 --

Column 21,

Line 16, change "thresh old" to -- threshold --

Signed and Sealed this

Second Day of September, 2003



JAMES E. ROGAN
Director of the United States Patent and Trademark Office

专利名称(译)	用于准确，基本上非侵入性地确定肺毛细血管血流量，心输出量和混合静脉二氧化碳含量的方法		
公开(公告)号	US6540689	公开(公告)日	2003-04-01
申请号	US09/510702	申请日	2000-02-22
[标]申请(专利权)人(译)	NTC TECH		
申请(专利权)人(译)	NTC TECHNOLOGY, INC.		
当前申请(专利权)人(译)	RIC投资有限责任公司.		
[标]发明人	ORR JOSEPH A KUCK KAI		
发明人	ORR, JOSEPH A. KUCK, KAI		
IPC分类号	A61B5/08 A61B5/083 A61B5/026 A61B5/087 G01N1/22 A61B5/00		
CPC分类号	A61B5/029 G01N33/497 A61B5/0836 G01N2001/2244		
外部链接	Espacenet USPTO		

摘要(译)

一种非侵入性地确定患者的肺毛细血管血流量或心输出量的方法，包括使用再呼吸技术来测量患者呼吸的呼吸流量和二氧化碳压力。这些测量用于计算二氧化碳消除和患者血液中二氧化碳含量的指标，例如二氧化碳 (PetCO₂)，CaCO₂或pCO₂的呼气末压力。通过二氧化碳消除数据和二氧化碳含量指标的数据的最佳拟合线的位置和取向通过线性回归或通过二氧化碳消除数据与二氧化碳含量指标的数据作图来确定。修改至少一组数据并且对最佳拟合线进行至少一个其他确定以找到与最佳拟合线最紧密相关的数据集。可以通过过滤或聚类来修改数据。然后使用与数据最密切相关的最佳拟合线的斜率来确定患者的肺毛细血管血流量或心输出量。当二氧化碳含量的指标是CaCO₂时，最佳拟合线的斜率的负值等于患者的肺毛细血管血流量。

