



US006506608B2

(12) **United States Patent**
Mault

(10) **Patent No.:** **US 6,506,608 B2**
(45) **Date of Patent:** ***Jan. 14, 2003**

(54) **METHOD AND APPARATUS FOR RESPIRATORY GAS ANALYSIS EMPLOYING MEASUREMENT OF EXPIRED GAS MASS**

2,838,399 A 6/1958 Vogel, Jr. 99/48
2,869,357 A 11/1959 Kritz 73/32

(List continued on next page.)

FOREIGN PATENT DOCUMENTS

(75) **Inventor:** **James R. Mault**, Evergreen, CO (US)

DE 198 10 476 9/1998
EP 0459647 2/1991
EP 0 712 638 12/1995
GB 2323292 9/1998
WO WO 96/40340 12/1996

(73) **Assignee:** **Healthetech, Inc.**, Golden, CO (US)

(*) **Notice:** Subject to any disclaimer, the term of this patent is extended or adjusted under 35 U.S.C. 154(b) by 0 days.

OTHER PUBLICATIONS

This patent is subject to a terminal disclaimer.

Medical Progress Through Technology, vol. 9, No. 1, 1982 Berlin (D), pp. 27-32, R. Salminen et al., "Computerized Breath-By-Breath Analysis of Respiratory Variables During Exercise".

(List continued on next page.)

(21) **Appl. No.:** **09/933,515**

Primary Examiner—Jeffrey Snay

(22) **Filed:** **Aug. 20, 2001**

(74) *Attorney, Agent, or Firm*—Gifford, Krass, Groh, Sprinkle, Anderson & Citkowski, P.C.

(65) **Prior Publication Data**

US 2002/0013536 A1 Jan. 31, 2002

(57) **ABSTRACT**

Related U.S. Application Data

(63) Continuation of application No. 09/674,897, filed as application No. PCT/US99/17553 on Aug. 3, 1999, now Pat. No. 6,277,645.

The oxygen and carbon dioxide content of expired respiratory gas is determined by measuring the mass and volume of the expired breath. From the composition of the inspired gas which may either be assumed or measured, the mass of the inspired volume may be determined, and since the inspired and expired breaths contain the same mass of nitrogen, the oxygen and carbon dioxide content of the expired breath may be determined. Measurements of temperature and humidity may be required to account for temperature and humidity changes between the inhalation and the exhalation or the inhaled gas may be adjusted in temperature and humidity to equalize the inhaled and exhaled temperature and humidity conditions. The mass and volume of the expiration and the volume mass of the inhalations are determined by an ultrasonic transit time system and a gas density sensor.

(60) Provisional application No. 60/095,092, filed on Aug. 3, 1998.

(51) **Int. Cl.⁷** **A61B 5/083**

(52) **U.S. Cl.** **436/133**; 436/136; 422/84

(58) **Field of Search** 436/133, 136, 436/62, 900; 422/84, 98; 600/531, 532, 538

(56) **References Cited**

U.S. PATENT DOCUMENTS

2,630,798 A 3/1953 White et al. 128/2.07
2,826,912 A 3/1958 Kritz 73/194
2,831,348 A 4/1958 Kritz 73/861.28

26 Claims, 2 Drawing Sheets

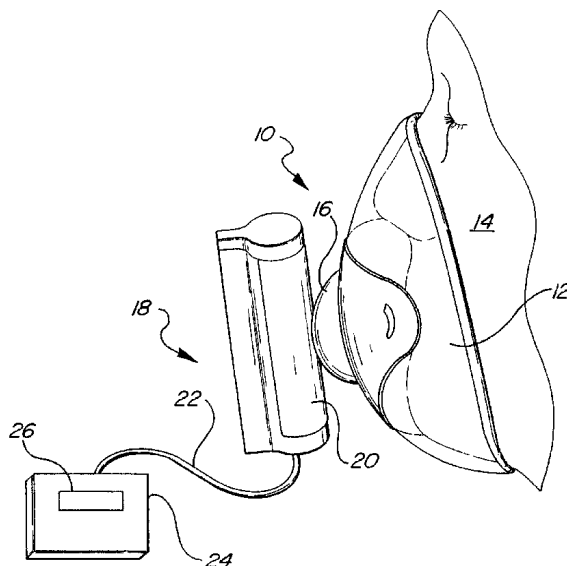

U.S. PATENT DOCUMENTS

2,911,825 A	11/1959	Kritz	73/194	5,072,737 A	12/1991	Goulding	128/718
2,920,012 A	1/1960	Sanders et al.	167/51.5	5,081,871 A	1/1992	Glaser	73/863.23
3,213,684 A	10/1965	Seaton et al.	73/190	5,095,900 A	3/1992	Fertig et al.	128/207.14
3,220,255 A	11/1965	Scranton et al.	73/204	5,095,913 A	3/1992	Yelderman et al.	128/719
3,250,270 A	5/1966	Bloom	128/2.07	5,117,674 A	6/1992	Howard	73/31.07
3,306,283 A	2/1967	Arp	128/2.07	5,119,825 A	6/1992	Huhn	600/529
3,523,529 A	8/1970	Kissen	128/2.07	5,178,155 A	1/1993	Mault	128/718
3,527,205 A	9/1970	Jones	128/2.08	5,179,958 A	1/1993	Mault	128/718
3,681,197 A	8/1972	Smith	195/63	5,214,966 A	6/1993	Delsing	73/861.28
3,726,270 A	4/1973	Griffis et al.	128/2.08	5,233,996 A	8/1993	Coleman et al.	600/529
3,797,480 A	3/1974	Williams	128/2.08	5,282,473 A	2/1994	Braig et al.	600/532
3,799,149 A	3/1974	Rummel et al.	128/2.07	5,285,794 A	2/1994	Lynch	128/719
3,814,091 A	6/1974	Henkin	128/188	5,293,875 A	3/1994	Stone	128/719
3,834,375 A	9/1974	Sanctuary et al.	128/2.07	5,299,579 A	4/1994	Gedeon et al.	600/532
3,895,630 A	7/1975	Bachman	128/2.07	5,303,712 A	4/1994	Van Duren	600/529
3,938,551 A	2/1976	Henkin	137/613	5,309,921 A	5/1994	Kisner et al.	600/532
3,962,917 A	6/1976	Terada	73/204	5,326,973 A	7/1994	Eckerbom et al.	250/343
4,003,396 A	1/1977	Fleischmann	137/83	5,355,879 A	10/1994	Brain	
4,051,847 A	10/1977	Henkin	128/145.6	5,357,972 A	10/1994	Norlien	128/725
4,078,554 A	3/1978	Lemaitre et al.	128/2.08	5,363,857 A	11/1994	Howard	600/531
4,186,735 A	2/1980	Henneman et al.	128/201.25	5,398,695 A	3/1995	Anderson et al.	600/532
4,188,946 A	2/1980	Watson et al.	128/204.22	5,402,796 A	4/1995	Packer et al.	128/719
4,197,857 A	4/1980	Osborn	600/531	5,419,326 A	5/1995	Harnoncourt	128/660.02
4,200,094 A	4/1980	Gedeon et al.	128/201.13	5,425,374 A	6/1995	Ueda et al.	600/532
4,211,239 A	7/1980	Raemer et al.	128/716	5,450,193 A	9/1995	Carlsen et al.	356/301
4,221,224 A	9/1980	Clark	128/718	5,468,961 A	11/1995	Gradon et al.	250/345
4,230,108 A	10/1980	Young		5,503,151 A	4/1996	Harnoncourt et al. ..	128/660.02
4,341,867 A	7/1982	Johansen	435/189	5,570,697 A	11/1996	Walker et al.	128/719
4,359,057 A	11/1982	Manzella	128/718	5,632,281 A	5/1997	Rayburn	128/719
4,368,740 A	1/1983	Binder	128/718	5,645,071 A	7/1997	Harnoncourt et al.	128/719
4,386,604 A	6/1983	Hershey	128/718	5,647,370 A	7/1997	Harnoncourt	128/725
4,428,805 A	1/1984	Ogura et al.	73/861.29	5,676,132 A	10/1997	Tillotson et al.	128/204.23
4,440,177 A	4/1984	Anderson et al.	600/532	5,705,735 A	1/1998	Acorn	73/23.3
4,444,201 A	4/1984	Itoh	128/716	5,728,585 A	3/1998	Yamamori et al.	436/133
4,463,764 A	8/1984	Anderson et al.	600/532	5,738,106 A	4/1998	Yamamori et al.	600/532
4,572,208 A	2/1986	Cutler et al.	128/718	5,754,288 A	5/1998	Yamamoto et al.	356/301
4,598,700 A	7/1986	Tamm	128/671	5,782,772 A	7/1998	Stegmann	600/520
4,608,995 A	9/1986	Linnarsson et al.	128/713	5,789,660 A	8/1998	Kofoed et al.	73/232
4,619,269 A	10/1986	Cutler et al.	128/719	5,796,009 A	8/1998	Delsing	73/861.28
4,648,396 A	3/1987	Raemer	600/534	5,800,360 A	9/1998	Kisner et al.	600/532
4,658,832 A	4/1987	Brugnoli	600/532	5,816,246 A	10/1998	Mirza	128/726
4,753,245 A	6/1988	Gedeon	128/718	5,831,175 A	11/1998	Fletcher-Haynes	73/861.28
4,756,670 A	7/1988	Arai	417/43	5,834,626 A	11/1998	DeCastro et al.	73/23.3
4,781,184 A	11/1988	Fife	128/205.12	5,836,300 A	11/1998	Mault	128/204.23
4,796,639 A	1/1989	Snow et al.	600/532	5,922,610 A	7/1999	Alving et al.	436/116
4,850,371 A	7/1989	Broadhurst et al.	600/532	5,932,812 A	8/1999	Delsing	73/861.02
4,856,531 A	8/1989	Merilainen	600/532	5,957,858 A	9/1999	Michaels et al.	600/532
4,909,259 A	3/1990	Tehrani	600/531	6,010,459 A	1/2000	Silkoff et al.	600/532
4,914,959 A	4/1990	Mylvaganam et al. ...	73/861.28	6,044,843 A	4/2000	O'Neil et al.	128/204.23
4,917,108 A	4/1990	Mault	128/718				
4,955,946 A	9/1990	Mount et al.	600/532				
4,986,268 A	1/1991	Tehrani	128/204				
4,998,018 A	3/1991	Kurahashi et al.	250/343				
5,022,406 A	6/1991	Tomlinson	128/719				
5,038,773 A	8/1991	Norlien et al.	128/205.23				
5,038,792 A	8/1991	Mault	128/718				
5,042,500 A	8/1991	Norlien et al.	600/532				
5,042,501 A	8/1991	Kenny et al.	600/532				
5,060,506 A	10/1991	Douglas	73/24.1				
5,060,655 A	10/1991	Rudolph	128/716				
5,060,656 A	10/1991	Howard	128/718				
5,069,220 A	12/1991	Casparie et al.	128/719				

OTHER PUBLICATIONS

British Journal Of Anaesthesia, vol. 49,1977 London (GB) pp. 575-587, J. A. Bushman et al. "Closed Circuit Anaesthesia".

IEEE Transactions On Biomedical Engineering, vol. 35, No. 9, Sep. 1988, pp. 653-659, Capek et al., "Noninvasive Measurement of Cardiac Output Using Partial CO₂ ReBreathing".

Clinics In Chest Medicine (Review), vol. 10, 1989, pp. 255-264, Heigenhauser et al., "Measurement of Cardiac Output by Carbon Dioxide Rebreathing Methods".

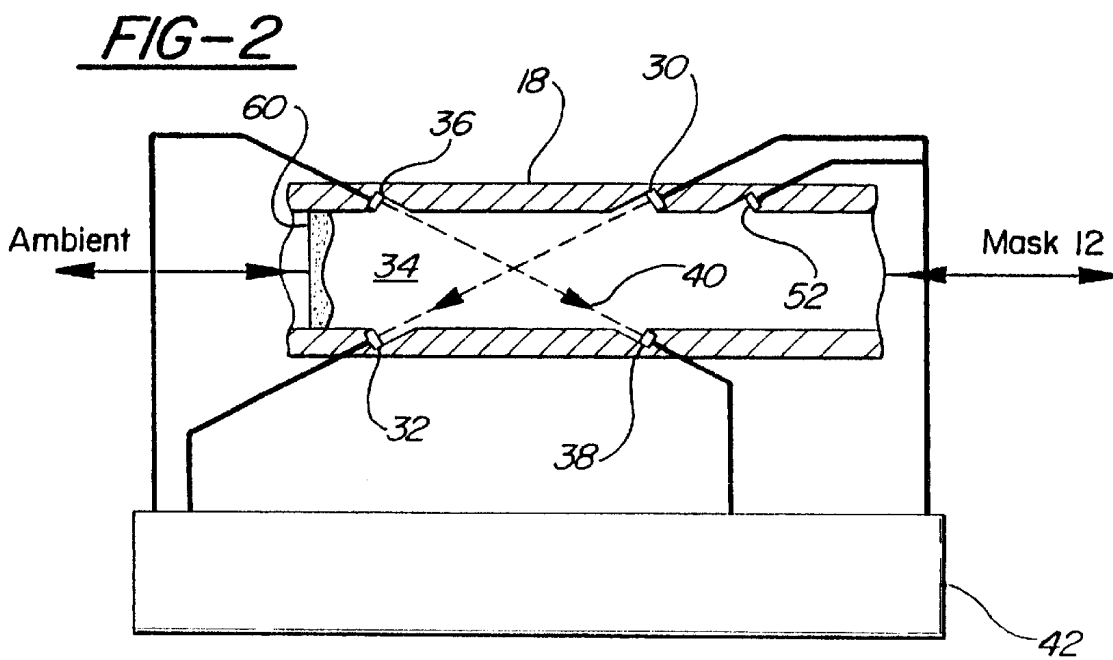
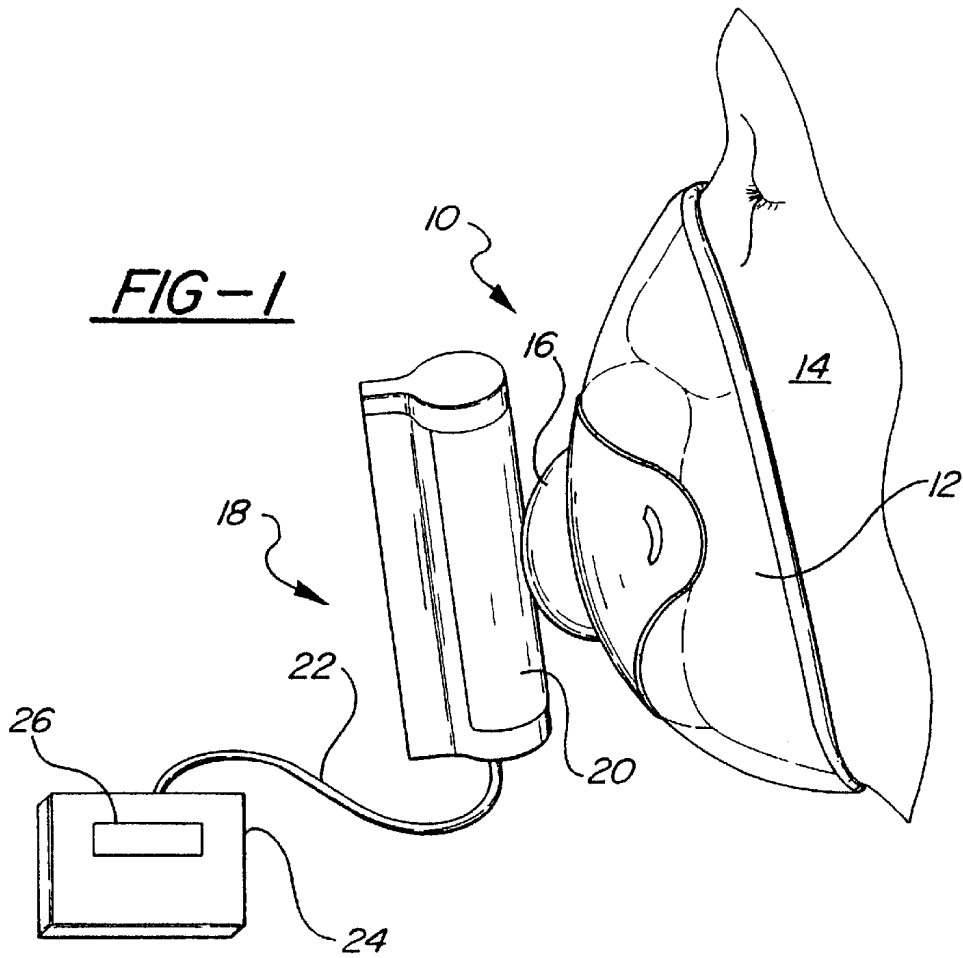

FIG-3

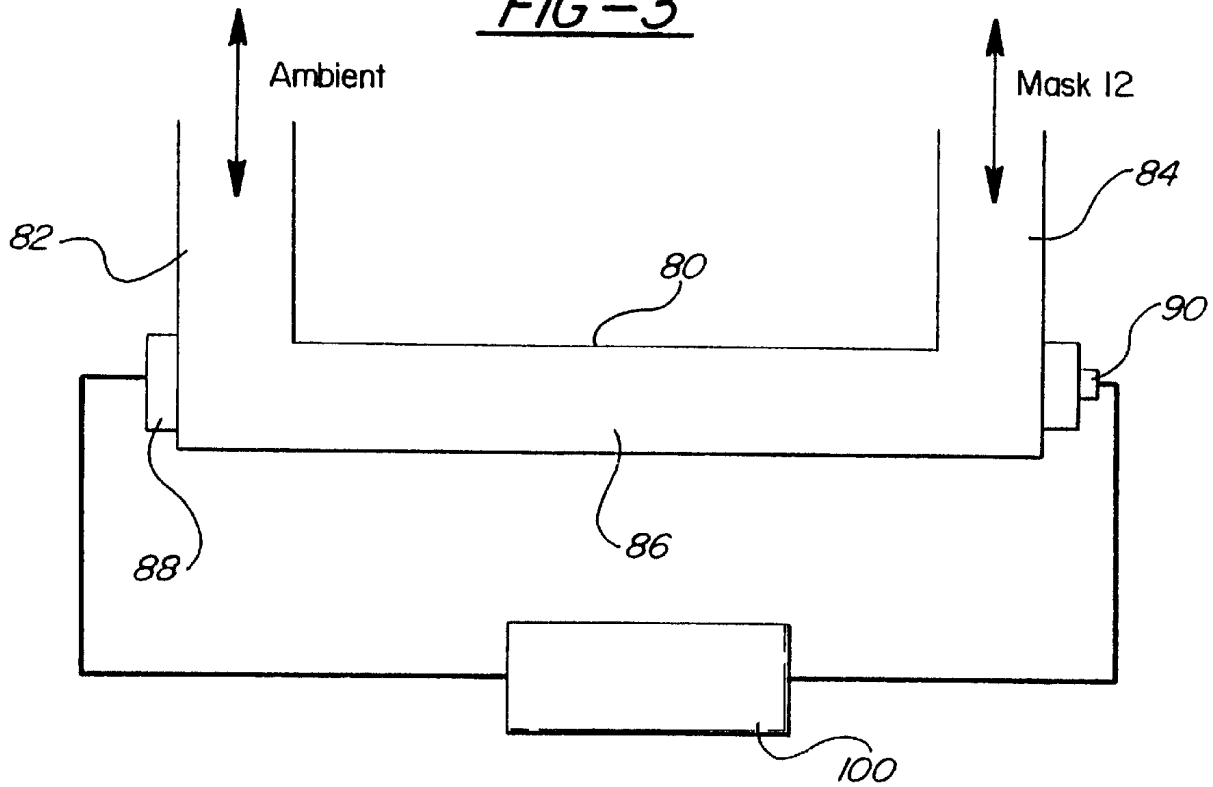
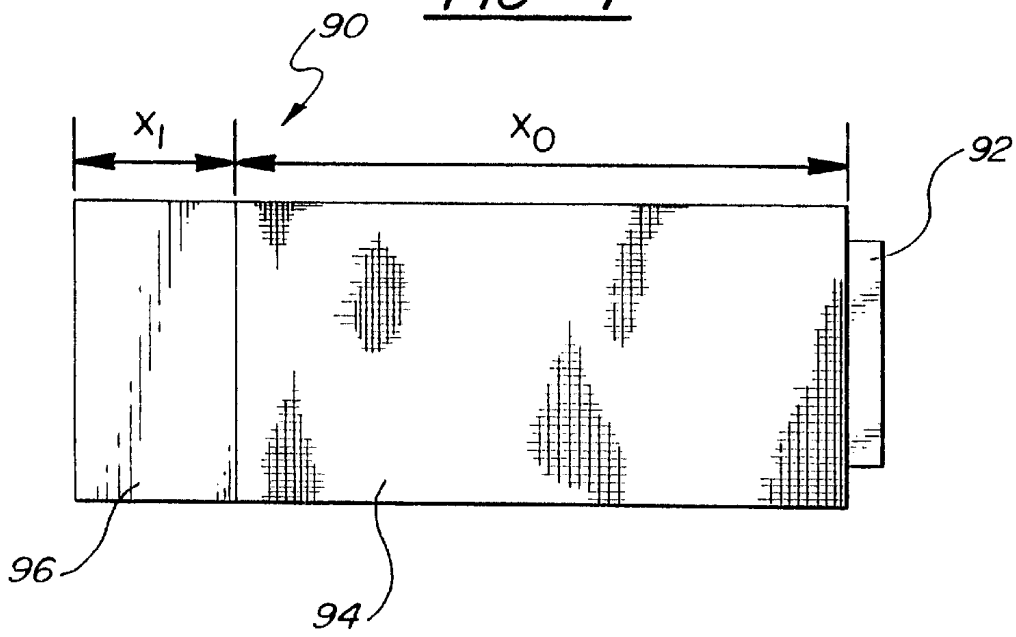

FIG-4



1

**METHOD AND APPARATUS FOR
RESPIRATORY GAS ANALYSIS
EMPLOYING MEASUREMENT OF EXPIRED
GAS MASS**

**CROSS REFERENCE TO RELATED
APPLICATIONS**

This application is a continuation of U.S. patent application Ser. No. 09/674,897, filed Nov. 7, 2000 now U.S. Pat. No. 6,277,645, which is a 371 of PCT/US99/17553, filed Aug. 3, 1999, which claims the benefit of U.S. Provisional Patent Application Serial No. 60/095,092, filed Aug. 3, 1998.

FIELD OF THE INVENTION

This invention relates to a method and apparatus for indirect calorimetry employing respiratory gas analysis and more particularly to a method and system which determines the oxygen and/or carbon dioxide content of the expired gas using measurements of mass and volume of the expired gas and mass and volume of the inspired gas as measured by transit time of ultrasonic pulses passed through the gas.

BACKGROUND OF THE INVENTION

I have a number of patents on respiratory calorimeters. Some of these operate by integrating the flow volume of a number of inhalations and exhalations over a period of time and by subtracting the CO₂ volume in the exhalation from the integral of the exhaled volume by scrubbing the CO₂ and then subtracting the exhaled flow volume less the CO₂ volume from the inhaled flow volume to determine oxygen consumption during the period. I also have a pending application that measures both inspired and expired volume and either O₂ or CO₂ content to determine oxygen consumption. The carbon dioxide scrubber is bulky and requires replenishment after a number of uses. Carbon dioxide or oxygen analyzers are also relatively expensive.

It has previously been proposed to determine the mass of a gas flowing through a conduit by determining the transit time of ultrasonic pulses passed through the gas in a direction having a component along the axis of flow so as to determine the flow rate of the gas, and additionally determining the density of the gas. U.S. Pat. No. 2,911,825 discloses such a system in which the acoustic impedance of the gas is measured to determine the density. U.S. Pat. No. 5,214,966 similarly employs the transit time of ultrasonic pulses to determine the flow rate and determines the density of the flowing gas through measurement of the velocity of sound through the gas. U.S. Pat. No. 5,645,071 uses the transit time of ultrasonic pulses to determine the flow rate and additionally makes temperature measurements which, with the flow rate, allow the determination of mass of the flowing gas. This latter patent also suggests the application of this device to pulmonary function diagnostics and discloses an additional gas analyzing sensor for determining the carbon dioxide and/or oxygen content of the flowing gas on an on-line, real time basis.

It would be desirable to provide a method of analysis which allows the determination of oxygen consumption, carbon dioxide production and related and derived respiratory factors without the need for any gas analyzers, such as O₂ and CO₂ analyzers. This would result in a low cost, high precision instrument suitable for a wide range of health care applications.

SUMMARY OF THE INVENTION

Accordingly, the present invention is directed toward a method and apparatus for analyzing respiratory gases to

2

determine oxygen consumption for indirect calorimetry purposes as well as CO₂ production and related respiratory factors, by measuring the mass and flow volume of expired gas without the need for additional analysis of the oxygen or CO₂ content of the expired gas, through use of measurements of the inhaled gas. In its simplest form, in which the constituents of the inhaled gas are known with sufficient precision, as is the case when the subject is breathing ambient air, and the temperature and humidity of the inspired and expired gases are the same as a result of passage through an artificial nose or the like, or are measured or assumed, the O₂ and CO₂ contents of the exhaled gases may be determined from measurements of the inhaled and exhaled flow volumes and the mass of the exhaled gases. Alternatively, the mass of the inhaled gas will also be measured. The measurements are preferably made by a subject breathing through the apparatus of the present invention for five to ten minutes with the measurements of the inhalations and exhalations being integrated over those periods.

To understand the method of the present invention and the system for implementing it, assume that the subject is breathing ambient air which has a composition of 79% nitrogen, 21% oxygen and 0.03% CO₂. By measuring the flow volume of the inhalations over the test period, the inhaled mass may be determined. Assuming that the exhalations are at the same humidity and temperature as the inhalations, from measurements of the integrated mass and flow volume of the exhalations the CO₂ and O₂ contents of the exhalations may be determined since the nitrogen content of the inhalations and exhalations will be the same, leaving only two unknowns, and after equalization for the differential in volumes between the inhaled gas the exhaled gas, the mass of the exhaled gas will vary linearly as a function of its CO₂ and O₂ content. The determination of the O₂ and CO₂ content of the expired volume is possible because CO₂ has a substantially higher density than O₂ and moles of O₂ and CO₂ occupy the same volume so that substitution of CO₂ in the exhaled gas for O₂ in the inhaled gas changes the gas mass but not the volume.

The system of the present invention preferably makes the flow measurements of the inhaled and exhaled volumes with known ultrasonic pulse transit time techniques and determines gas density with measurements such as acoustic impedance, speed of sound, or temperature. The same apparatus can measure the masses and flow volumes of the inhaled and exhaled gases.

BRIEF DESCRIPTION OF THE DRAWINGS

The invention will be further described in conjunction with the accompanying drawings, in which:

FIG. 1 is a perspective drawing of a preferred embodiment of the invention, being used by a subject to allow determination of the subject's respiratory parameters;

FIG. 2 is a cross sectional view of the flow tube forming part of the preferred embodiment of the invention, illustrating the associated electronics in block form;

FIG. 3 is a schematic drawing of an alternative embodiment of the invention; and

FIG. 4 is a drawing of an ultrasonic transducer capable of measuring the acoustic impedance of the flowing gas.

**DETAILED DESCRIPTION OF THE
PREFERRED EMBODIMENTS**

Referring to FIG. 1, a preferred embodiment of the invention comprises a calorimeter, generally indicated at 10,

having a mask **12** formed at one end which is adapted to engage the face of a user **14** so as to cover the nose and mouth. The mask connects via a conduit **16** to a test body **18** incorporating a flow tube **20**. One end of the flow tube **20** connects to the ambient air. As the user **14** inhales during a breathing test, which may last from two to ten minutes, ambient air is drawn in, passes through the flow tube **20** and to the user **14** through the mask **12**. As the user exhales, air moves from the mask **12**, through the conduit **16**, through the flow tube **20**, to the ambient air. In alternative embodiments of the invention, the source and sink for the respiratory gases may be conditioned air as used in forced respiratory apparatus.

A cable **22** connects to the test body **18** and carries electrical signals between the test body and a computation unit **24**. The computation unit preferably includes a display **26** which may be switched to display the various results of the test and instructions to the user such as "start test" and "stop test." The flow tube **20** and the mask **12** are preferably formed as a disposable unit so that they may be replaced between uses for hygienic purposes. The balance of the system including the test body **18** and computation unit **24** are preferably reusable. The breath under test only passes through the disposable portions of the system.

FIG. 2 illustrates the disposable flow tube **18** in cross section. The flow tube and its associated components are of the type illustrated in U.S. Pat. No. 2,911,825 which is operative to calculate the flow rate of the inhaled and exhaled respiratory gases through the tube **18** and to calculate the density of the gases via a determination of the acoustic impedance of the flowing gases. As illustrated in FIG. 2, the left end of the flow tube **18** connects to the atmosphere so that ambient air is drawn into the flow tube when the user inhales and exhaled air is returned to the ambient. The right hand end of the flow tube connects to the mask **12**. Thus, inhalations pass through the tube to the right and exhalations pass through the tube **18** to the left.

A pair of piezoelectric crystals **30** and **32** are mounted on opposite sides of the flow tube **18** at an angle to the central axis of the flow tube so that they face one another and ultrasonic pulses may be sent from the crystal **30** to the crystal **32** in the direction of the arrow **34**. Similarly, a pair of crystals **36** and **38** are supported on opposite sides of the tube so that they face one another, at an angle to the central axis of the tube, in the direction of the arrow **40**. Electrical connections are made from each of the crystals to an electronic control and computation circuit **42** which may be generally of the type illustrated in FIG. 1 of U.S. Pat. No. 2,911,825.

Additionally, another piezoelectric crystal transducer **52** is mounted in a wall of the flow tube **18** so as to contact the gases flowing through the tube. Signals from the transducer **30** are also provided to the computation and control unit **42**. Essentially, the control unit controls the crystals **30** and **36** to transmit ultrasonic pulses to the crystals **32** and **38** respectively. The circuitry for generating the pulses and to receive the detected pulses is contained in the unit **42**. Since the time of flight of these pulses between the transmitting and receiving crystals is a function of their separation and the rate of flow of gases through the tube, the flow rate may be calculated as a function of the difference between the transit times of the pulses between the two sets of crystals.

The transducer **52** forms one part of a resonance circuit controlled by an oscillator in the unit **42**. The frequency of the oscillator is adjusted until the transducer **30** is tuned to series resonance and the voltage drop across the transducer

52 is measured by circuitry contained in the unit **42**. This voltage is a measure of the acoustic impedance of the fluid. The density of the fluid is equal to the acoustic impedance divided by the wave propagation velocity through the fluid as fully explained in U.S. Pat. No. 2,869,357. Thus, the computation unit receives signals proportional to the flow rate of gases through the flow tube and the density of those gases and the mass can be calculated. Since the interior diameter of the flow tube **18** is known, the flow volume may be calculated.

The computation unit **42** thus measures the flow volume of the inhalations, the flow volume of the exhalations, and the mass of the exhaled volume.

The unit may incorporate a conventional artificial nose **60** which passes both the inhalations and exhalations and accumulates moisture from the exhalations and generally equalizes the temperature and humidity of the inhalations and exhalations. Alternatively, these temperatures and humidities may be measured or they may be conditioned by active elements such as a thermistor and humidifier.

Assuming that the temperature and humidity of the inhalations and exhalations are equal, the O₂ and CO₂ composition of the exhalation may easily be computed. The mass of the exhalations is first equalized on the basis of the flow volumes of the inhalations and exhalations. The mass of nitrogen in the inhalations is computed and that mass is subtracted from the mass of the exhaled gas. The remaining mass composed of O₂ and CO₂ and the mass will vary linearly depending on the proportions of those components so they can be computed or determined from a look-up table. The remaining mass is linearly related to the percentages of CO₂ and O₂ in the exhalation.

FIG. 2 illustrates the flow tube and associated circuitry of a second embodiment of the invention which uses the method and apparatus disclosed in U.S. Pat. No. 5,214,966 for the determination of the flow velocity and the sound velocity of the respiratory gases passing through the flow tube. The mass of the flowing gas may be calculated using the flow velocity and the sound velocity in the manner set forth in that patent. The flow tube **80** of the second embodiment of the invention is U-shaped with two legs **82** and **84** extending parallel to one another and at right angles to a central connecting section **86**. The leg **82** connects the central section **86** to a source and sink for respiratory gases which is preferably the ambient air. The leg **84** connects the other end of the section **86** to the mask **12** illustrated in FIG. 1 or another respiratory connector such a mouthpiece.

A first ultrasonic transducer **88** is disposed in the wall of the tube **80** at one end of the connecting section **86** in direct opposition to a second ultrasonic transducer **90** which is disposed at the opposite end so that the two face one another. Each of the two transducers **88** and **90** is formed with a piezoelectric crystal acting as both a transmitter and receiver of ultrasonic pulses. The transducer **90**, which is illustrated in detail in FIG. 4, is especially designed for measuring the density of the gases flowing through the flow tube **80**. As illustrated in FIG. 2, the transducer **90** consists of a piezoelectric transducer **92**, a first block **94** of a material having an acoustic impedance Z_0 and a length X_0 , and a second block **96** having an acoustic impedance Z_1 and a length X_1 . The two blocks **94** and **96** are disposed in such a manner that an ultrasonic pulse transmitted from the crystal **92** will transverse the two blocks **94**, **96** before reaching the gas. The first block **94** being disposed between and in contact with the crystal **92** and the second block **96**, and the second block **96** is disposed between and in contact with the first block **94**

and the gas flowing through the tube **80**. The two transducers **88** and **90** are connected to a computation and control unit **100** which contains control and computation electronics. The unit **100** includes sing-around electronic circuitry of a well known type and includes a microprocessor that calculates the flow velocity of gases passing through the section **86** of the flow tube **80**.

Simultaneously, the signals from the crystal **90** are used to determine the density of the gas flowing through the section **86** based on the reflection of pulses generated by the transducer **92** from the interface between the crystals **94** and **96**, the interface between the crystal **96** and the flowing gas, and the amplitude of those reflections. This is all done in the manner described in U.S. Pat. No. 5,214,966 and will not be repeated. Again, the mass of the exhalations may be calculated from the integrated flow volume density measurements. The flow volume of the inhalation may also be computed and used along with the exhaled volume to analyze the mass reading. The normalized mass will be a function of its complementary O₂ and CO₂ constituents.

In another embodiment only the expired mass and volume are measured. The expired O₂ concentration [O₂]_e and the expired CO₂ concentration [CO₂]_e are calculated from the expired mass and volume, and, knowing the inspired O₂ concentration [O₂]_i, then V_{o₂} is calculated by the following formula:

$$V_{O_2} = \frac{1 - [O_2]_e - [CO_2]_e}{1 - [O_2]_i} \times ([O_2]_i - [O_2]_e) V_e \times k$$

where k is a non-adiabatic correction constant to compensate for the non-ideal nature of the gases, determinable from the van der Waals equation.

The expired volume V_e is a summation of partial volumes attributable to each of the constituent gas making up the expired volume. Since the inhaled oxygen concentration is known or determinable independent of the present invention, the volume of oxygen in the exhalant is related to the exhalant mass change associated with the molar concentrations of oxygen and carbon dioxide relative to inhalant gas. CO₂ volume is calculated as:

$$V_{CO_2} = [CO_2]_e \times V_e$$

Where V_e is the total expiration volume.

Having thus described my invention I claim:

1. A method of analyzing exhaled breath produced by a subject over a measurement period, the method comprising:

determining an exhaled mass of the exhaled breath by integrating a plurality of flow rate determinations and a plurality of density determinations for the exhaled breath passing through a flow tube during the measurement period, wherein the plurality of flow rate determinations for the exhaled breath and the plurality of density determinations for the exhaled breath are determined by passing a plurality of ultrasonic pulses through at least part of the flow tube as the exhaled breath passes therethrough;

determining an exhaled volume of the exhaled breath by integrating a plurality of flow rate determinations for the exhaled breath passing through the flow tube during the measurement period;

determining an inhaled nitrogen mass using an inhaled volume of inhaled gases during the measurement period and an inhaled composition of inhaled gases, and determining an exhaled nitrogen mass as equal to the inhaled nitrogen mass;

subtracting the exhaled nitrogen mass from the exhaled mass of the exhaled breath, so as to determine a mass of residue exhaled gas, wherein the residue exhaled gas is substantially a mixture of carbon dioxide and oxygen; and

determining a composition of the residue exhaled gas from the exhaled volume of the exhaled gas and the mass of residue exhaled breath.

2. The method of claim **1**, wherein the measurement period extends over a plurality of breaths of the subject.

3. The method of claim **1**, further comprising the determination of an exhaled carbon dioxide volume from the composition of the residue exhaled gas and the exhaled volume of the exhaled gas.

4. The method of claim **1**, further comprising the determination an exhaled oxygen volume from the composition of the residue exhaled gas and the exhaled volume.

5. The method of claim **1**, further comprising, the determination of a consumed volume of oxygen by subtracting the exhaled oxygen volume from an inhaled oxygen volume inhaled during the measurement period.

6. The method of claim **1**, wherein the inhaled composition is equal to an atmospheric composition comprising substantially of 79% nitrogen and 21% oxygen.

7. The method of claim **1**, wherein the inhaled volume is determined by an integration of a plurality of flow rate determinations for inhaled breath passing through the flow tube during the measurement period.

8. The method of claim **1**, wherein the inhaled composition is determined by integrating a plurality of flow rate determinations and density determinations for inhaled breath passing through the flow tube during the measurement period.

9. The method of claim **1**, wherein the flow path has a cross-sectional area wherein the determination of exhaled mass and the determination of exhaled volume both include a step of multiplying by the cross-sectional area.

10. A method of analyzing the respiration of a subject during a multi-breath test, during which multi-breath test the subject inhales an inhaled volume of inhaled gas having an inhaled gas composition, and exhales an exhaled volume of exhaled gas having an exhaled mass, the method comprising:

determining the exhaled mass by integrating flow rate data and flow density data acquired during the multi-breath test, wherein the flow rate data are acquired by determining transit times of a plurality of ultrasonic pulses through the exhaled gas, and wherein the flow density data are acquired by determining speeds of sound or acoustic impedances relating to the exhaled gas;

subtracting a nitrogen mass from the exhaled mass so as to substantially determine a mass of exhaled carbon dioxide and oxygen, wherein the nitrogen mass is determined from the inhaled volume and the inhaled volume composition; and

determining an exhaled composition from the exhaled volume and the mass of exhaled carbon dioxide and oxygen.

11. The method of claim **10**, wherein the flow density data are acquired by determining speeds of sound relating to the exhaled gas.

12. The method of claim **10**, wherein the flow density data are acquired by determining acoustic impedances relating to the exhaled gas.

13. The method of claim **10**, further comprising the determination an exhaled carbon dioxide volume from the exhaled composition and the exhaled volume.

- 14. The method of claim 10, further comprising the determination an exhaled oxygen volume from the exhaled composition and the exhaled volume.
- 15. The method of claim 10, further comprising the determination of a consumed oxygen volume, by subtracting the exhaled oxygen volume from an inhaled oxygen volume.
- 16. A respiratory analyzer, comprising
 - a flow tube, through which inhaled gas and exhaled gas flow;
 - at least two ultrasonic transducers, adapted to communicate ultrasonic signals through at least part of the flow tube;
 - circuitry adapted to determine a flow velocity of gas passing through the flow tube, wherein the flow velocity is determined using signals received from the ultrasonic transducers;
 - means for determining a density of gas passing through the flow tube; and
 - a calculation module adapted to determine an exhaled mass from determinations of flow velocity and determinations of density for exhaled gas passing through the flow tube, further to determine an exhaled volume from determinations of flow velocity for exhaled gas passing through the flow tube, further to determine an inhaled nitrogen mass from the inhaled volume and an inhaled gas composition, and to determine the composition of the exhaled gas from the exhaled mass minus the inhaled nitrogen mass.
- 17. The analyzer of claim 16, wherein the calculation module is further adapted to determine the inhaled volume from flow velocity determinations for inhaled gas passing through the flow tube.
- 18. The analyzer of claim 16, wherein the calculation module is further adapted to determine an exhaled carbon dioxide volume from the composition of the exhaled gas and the exhaled volume.
- 19. The analyzer of claim 16, wherein the calculation module is further adapted to determine an exhaled oxygen volume from the composition of the exhaled gas and the exhaled volume.
- 20. The analyzer of claim 16, wherein the calculation module is further adapted to determine a consumed oxygen volume by subtracting the exhaled oxygen volume from and an inhaled oxygen volume, wherein the inhaled oxygen volume is determined from the inhaled volume of gas and the inhaled gas composition.

- 21. The analyzer of claim 16, wherein the means for determining a density of gas passing through the flow tube comprises an ultrasonic resonance circuit.
- 22. The analyzer of claim 16, wherein the means for determining a density of gas passing through the flow tube comprises at least two ultrasonic transducers configured to exchange ultrasonic pulses through at least part of the flow tube.
- 23. The analyzer of claim 16, further comprising a means for determining temperature.
- 24. The analyzer of claim 16, further comprising a means for determining humidity.
- 25. The analyzer of claim 16, wherein the ultrasonic transducers each comprise a piezoelectric crystal in contact with a first block, the first block being in contact with a second block, the second block being in contact with gas in the flow tube, the first and second blocks to having different acoustic impedances.
- 26. A respiratory analyzer, for use in a breath test during which a person inhales an inhaled volume of inhaled gas having an inhaled gas of exhaled gas having an exhaled mass, the apparatus comprising:
 - a flow path, through which the exhaled gas and the inhaled gas flow;
 - a pair of ultrasonic transducers, disposed so that an ultrasonic pulse transmitted by a first ultrasonic transducer is received by a second ultrasonic transducer, and so that the ultrasonic pulse passes through at least part of the flow path;
 - circuitry adapted to determine a flow rate and a speed of sound for gas within the flow path, wherein the flow rate and the speed of sound are determined using transit times of a plurality of ultrasonic pulses passed between the pair of ultrasonic transducers; and
 - a calculation unit adapted to determine the inhaled volume, the exhaled volume, the exhaled mass, an exhaled nitrogen mass, and an exhaled gas composition,
 wherein the exhaled nitrogen mass is determined from the inhaled volume and the inhaled gas composition, the exhaled gas composition is determined from the exhaled mass minus the exhaled nitrogen mass, and the exhaled mass is determined from a plurality of flow rate determinations and a plurality of speed of sound determinations acquired during times when exhaled breath passes through the flow path.

* * * * *

UNITED STATES PATENT AND TRADEMARK OFFICE
CERTIFICATE OF CORRECTION

PATENT NO. : 6,506,608 B2
DATED : January 14, 2003
INVENTOR(S) : Mault

Page 1 of 1

It is certified that error appears in the above-identified patent and that said Letters Patent is hereby corrected as shown below:

Column 1,

Line 11, replace "Aug." with -- September --.

Column 6,

Line 34, replace "are" with -- area --.

Column 8,

Line 16, replace "blocks to" with -- blocks --.

Line 20, after "inhaled gas" insert -- composition, and exhales an exhaled volumn --.

Signed and Sealed this

Twenty-second Day of July, 2003

A handwritten signature in black ink, appearing to read "James E. Rogan", with a horizontal line drawn underneath it.

JAMES E. ROGAN

Director of the United States Patent and Trademark Office

专利名称(译)	使用呼出气体质量测量的呼吸气体分析方法和装置		
公开(公告)号	US6506608	公开(公告)日	2003-01-14
申请号	US09/933515	申请日	2001-08-20
[标]申请(专利权)人(译)	詹姆士R.莫特		
申请(专利权)人(译)	MAULT JAMES R.		
当前申请(专利权)人(译)	HEALTHETECH INC.		
[标]发明人	MAULT JAMES R		
发明人	MAULT, JAMES R.		
IPC分类号	A61B5/087 A61B5/08 A61B5/083 G01F1/66 A61B5/00 A61B8/00 A61M16/00 G01H15/00 G01K17/00 G01N25/20 G01N29/024 G01N33/497		
CPC分类号	A61B5/083 A61B5/087 G01N29/024 G01F1/66 A61B5/01 A61M2016/0042 Y10T436/207497 G01N2291/02836 G01N2291/02881 G01N2291/02818 Y10T436/204998		
其他公开文献	US20020013536A1		
外部链接	Espacenet USPTO		

摘要(译)

呼出气体的氧气和二氧化碳含量通过测量呼出气体的质量和体积来确定。根据可以假定或测量的吸入气体的成分，可以确定吸气体积的质量，并且由于吸气和呼气呼吸包含相同质量的氮气，呼出气体的氧气和二氧化碳含量可以确定。可能需要测量温度和湿度以考虑吸入和呼气之间的温度和湿度变化，或者可以调节吸入的气体的温度和湿度以平衡吸入和呼出的温度和湿度条件。呼气的质量和体积以及吸入的体积质量由超声波传输时间系统和气体密度传感器确定。

