



US006438400B1

(12) **United States Patent**
Beard et al.

(10) **Patent No.:** **US 6,438,400 B1**
(45) **Date of Patent:** **Aug. 20, 2002**

(54) **ELECTRODE FOR EVALUATING CARDIAC FUNCTIONS VIA ESOPHAGUS**

(75) Inventors: **Lane Beard**, Waukesha, WI (US);
James P. Howard, Jefferson City, MO (US);
Donald J. Melnikoff, Franklin; **Robert L. Young**, Waukesha, both of WI (US)

(73) Assignee: **Heska Corporation**, Ft. Collins, CO (US)

(*) Notice: Subject to any disclaimer, the term of this patent is extended or adjusted under 35 U.S.C. 154(b) by 0 days.

(21) Appl. No.: **09/513,737**

(22) Filed: **Feb. 22, 2000**

Related U.S. Application Data

(63) Continuation-in-part of application No. 09/230,666, filed as application No. PCT/US98/08271 on Apr. 24, 1998, now Pat. No. 6,266,549, application No. 09/513,739, which is a continuation-in-part of application No. 09/020,475, filed on Feb. 9, 1998, now Pat. No. 6,322,518, which is a continuation-in-part of application No. 08/546,246, filed on Oct. 20, 1995, now Pat. No. 5,715,816, which is a continuation-in-part of application No. 08/412,287, filed on Mar. 28, 1995, now Pat. No. 5,743,261, which is a continuation-in-part of application No. 08/163,052, filed on Dec. 6, 1993, now Pat. No. 5,417,207.

(60) Provisional application No. 60/045,006, filed on Apr. 25, 1997, and provisional application No. 60/067,810, filed on Dec. 4, 1997.

(51) **Int. Cl.**⁷ **A61B 5/042**

(52) **U.S. Cl.** **600/380; 607/124**

(58) **Field of Search** **600/373-381; 607/115-122, 124, 137, 141; 606/41, 51**

(56) **References Cited**

U.S. PATENT DOCUMENTS

1,103,669 A * 7/1914 Gibbs 607/147
3,340,867 A 9/1967 Kubicek et al.
3,703,168 A 11/1972 Frink

3,951,136 A 4/1976 Wall
4,176,660 A 12/1979 Mylrea et al.
4,304,240 A 12/1981 Perlin
4,349,031 A 9/1982 Perlin
4,369,794 A 1/1983 Furler
4,450,527 A 5/1984 Sramek
4,476,872 A 10/1984 Perlin

(List continued on next page.)

FOREIGN PATENT DOCUMENTS

DE 2003138 * 7/1971 600/380
EP 0366127 A1 10/1989
GB 1454066 10/1976
WO WO 96/29927 10/1996
WO WO 98/48692 11/1998

Primary Examiner—Lee Cohen

(74) *Attorney, Agent, or Firm*—Snell & Wilmer L.L.P.

(57) **ABSTRACT**

An electrode useful for generating or receiving electrical signals generally comprises a base and more than one dome-like protuberance on an exterior surface of the base. The electrodes can be utilized in connection with various probe applications. For example, the electrodes can be utilized with an esophageal probe for invasively monitoring cardiac functions, including the ECG or cardiac output of a patient. To further minimize the differences in voltage potential as may be caused by electrolytes present at the point of contact, a gold-plated layer may be provided on the outer surface of the electrodes. An exemplary probe generally comprises a chassis with an electrical cable extending from the proximal end of the chassis and with the cable terminating at an electrical plug configured for connection to a cardiac monitor. The probe also includes an electrode assembly comprising the dome-like protuberances and configured to generate or receive electrical signals that are indicative of the cardiac functions of the patient. The probe may further include a deployment device attached to the chassis for stabilizing the probe within the esophagus. The probe may also be configured to include other sensing devices, for example, a temperature measuring device and an acoustic monitor.

23 Claims, 10 Drawing Sheets

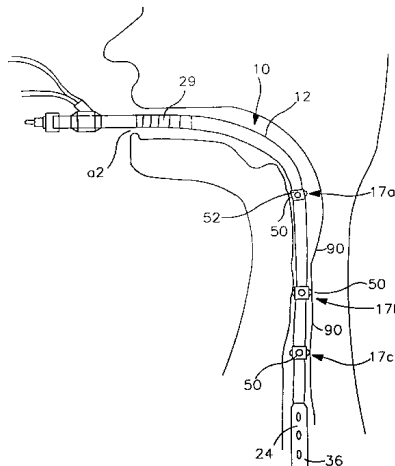

U.S. PATENT DOCUMENTS

4,522,205 A	*	6/1985	Taylor et al.	600/375	5,387,232 A	2/1995	Trailer	
4,559,951 A		12/1985	Dahl et al.		5,394,880 A	3/1995	Atlee, III	
4,706,688 A		11/1987	Michael et al.		5,395,363 A	*	3/1995	Billings et al. 606/41
4,817,611 A		4/1989	Arzbaecher et al.		5,423,326 A		6/1995	Wang et al.
4,819,647 A	*	4/1989	Byers et al.	607/116	5,431,696 A		7/1995	Atlee, III
4,836,214 A		6/1989	Sramek		5,443,073 A		8/1995	Wang et al.
4,890,623 A	*	1/1990	Cook et al.	607/122	5,556,425 A		9/1996	Hewson et al.
4,960,133 A	*	10/1990	Hewson	600/380	5,693,052 A	*	12/1997	Weaver
5,109,851 A		5/1992	Jadvar et al.		5,715,816 A		2/1998	Mainiero et al.
5,170,803 A		12/1992	Hewson et al.		5,722,401 A	*	3/1998	Pietroski et al. 607/122
5,197,491 A		3/1993	Anderson et al.		5,749,833 A		5/1998	Hakki et al.
5,199,433 A		4/1993	Metzger et al.		5,919,220 A	*	7/1999	Stieglitz et al. 607/118
5,275,162 A		1/1994	Edwards et al.		5,967,977 A	*	10/1999	Mullis et al. 600/380
5,309,917 A		5/1994	Wang et al.		6,052,608 A	*	4/2000	Young et al. 600/378
5,324,322 A	*	6/1994	Grill, Jr. et al.	607/118	6,256,540 B1	*	7/2001	Panescu et al. 607/122
5,357,954 A		10/1994	Shigezawa et al.		6,266,549 B1	*	7/2001	Melnikoff et al. 600/380

* cited by examiner

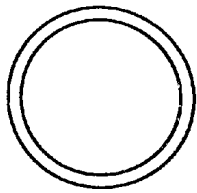

FIG. IB
PRIOR ART

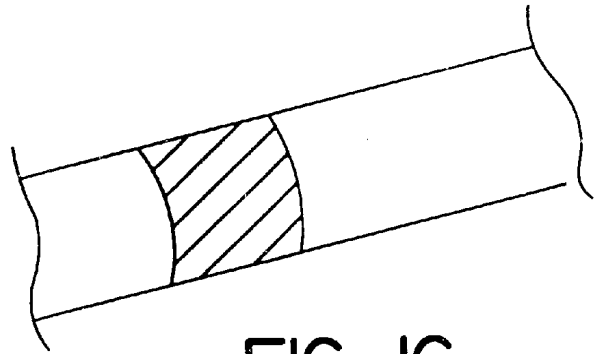

FIG. IC
PRIOR ART



FIG. IA
PRIOR ART

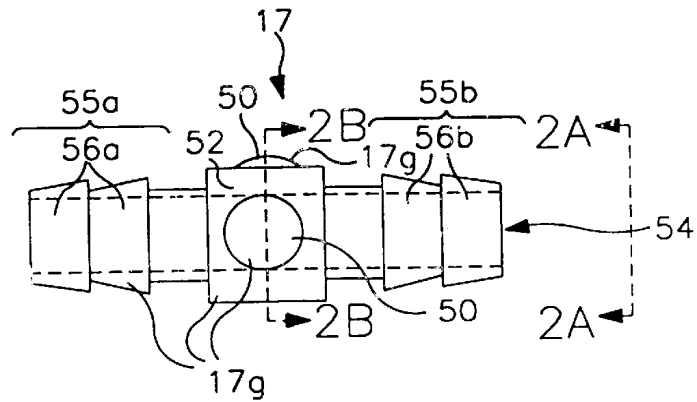

FIG. 2

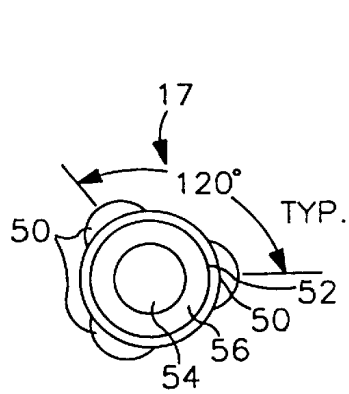

FIG. 2A

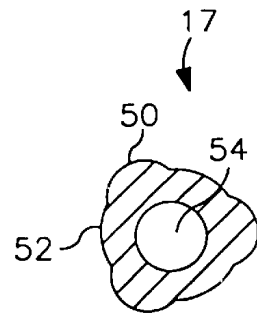

FIG. 2B

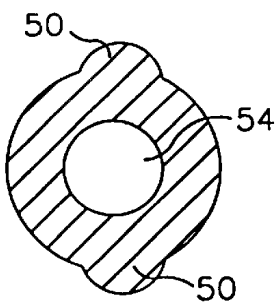

FIG. 3

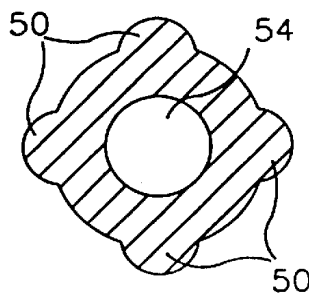

FIG. 4

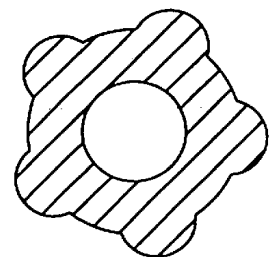

FIG. 5

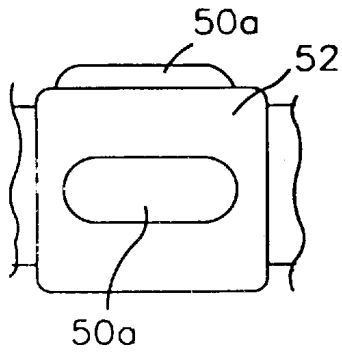

FIG. 6A

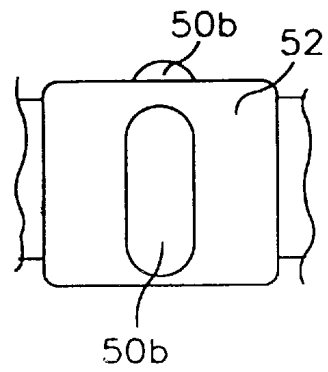

FIG. 6B

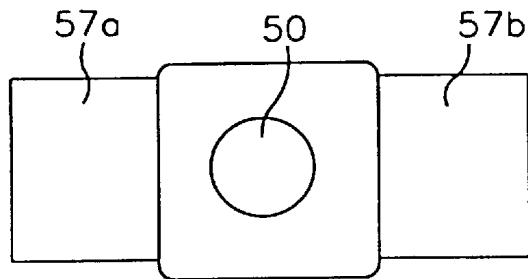

FIG. 7

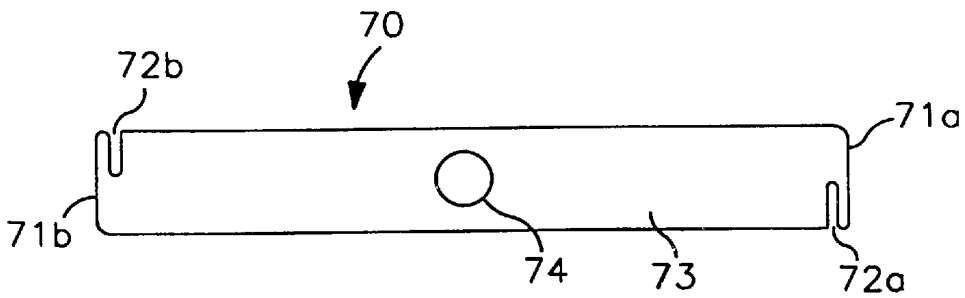

FIG. 8A

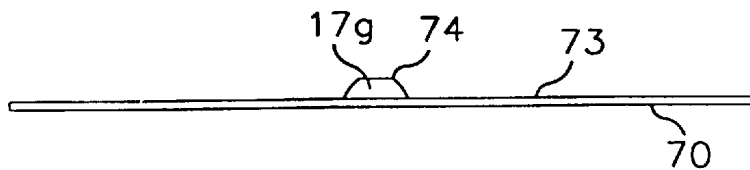

FIG. 8B

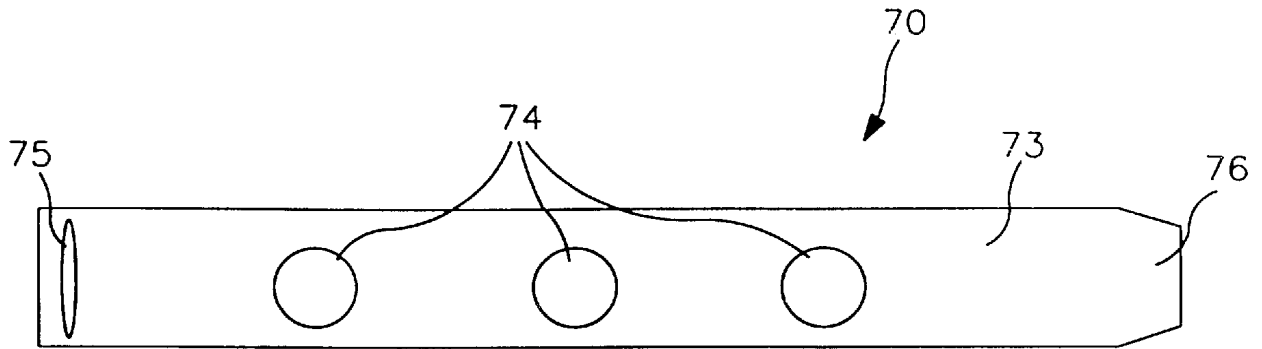

FIG. 9

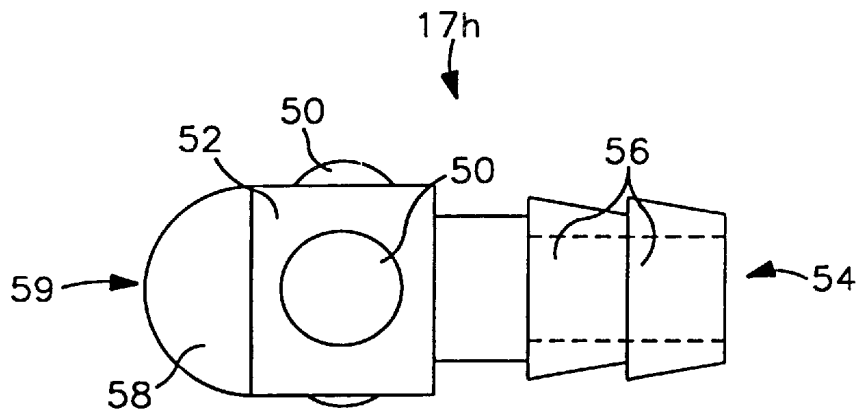
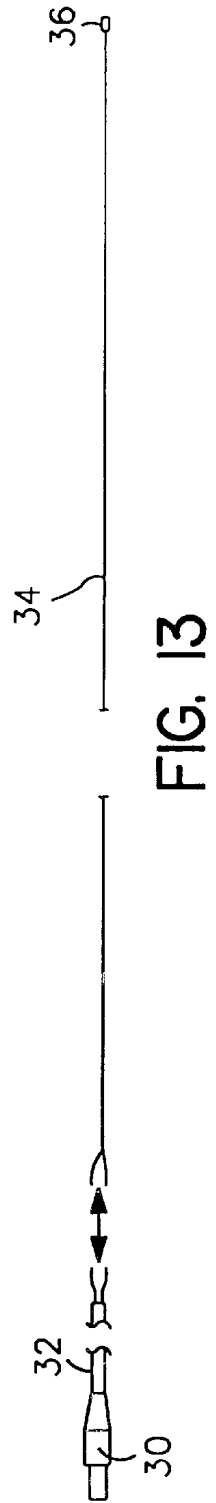
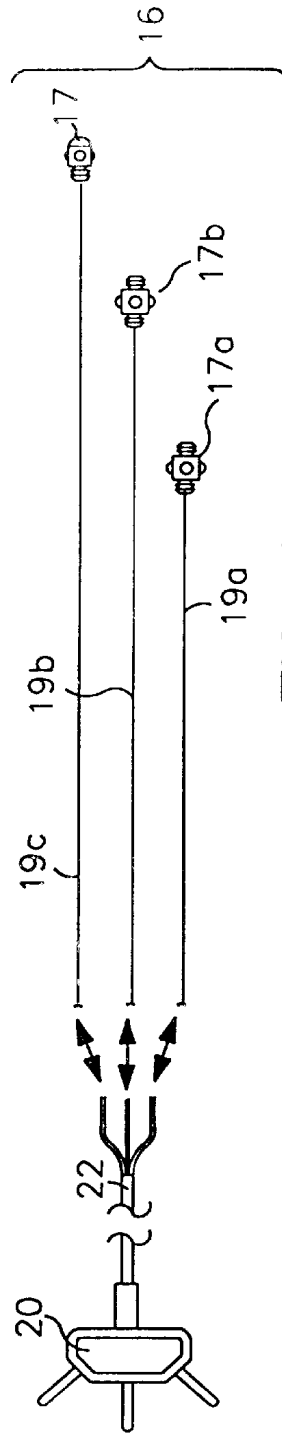
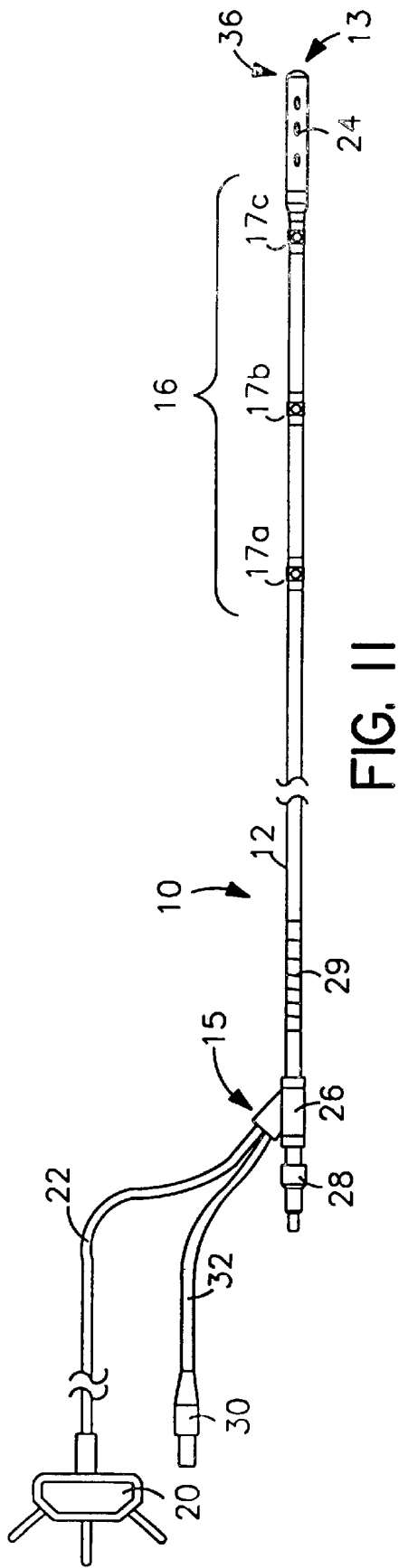

FIG. 10



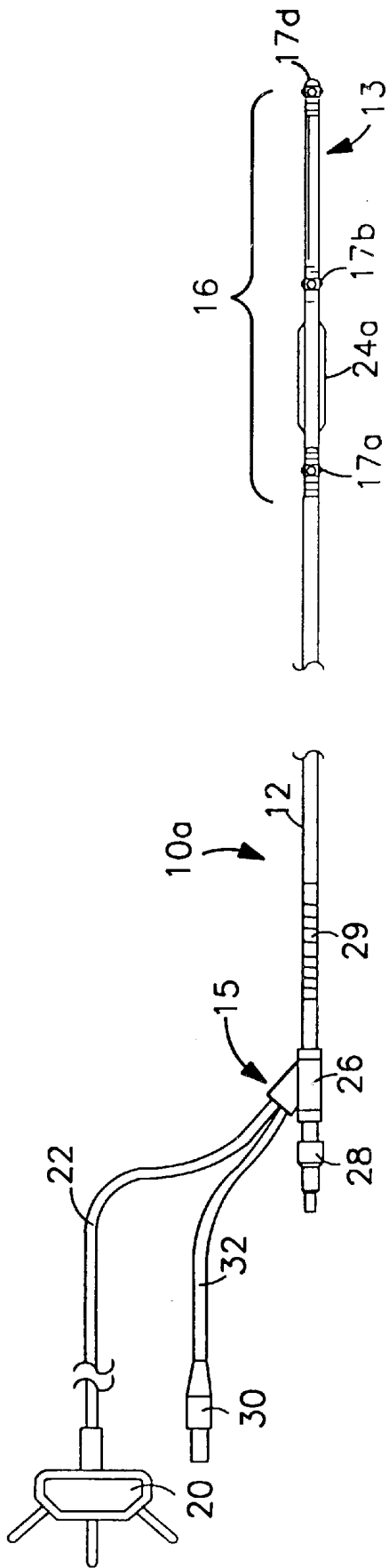

FIG. 14

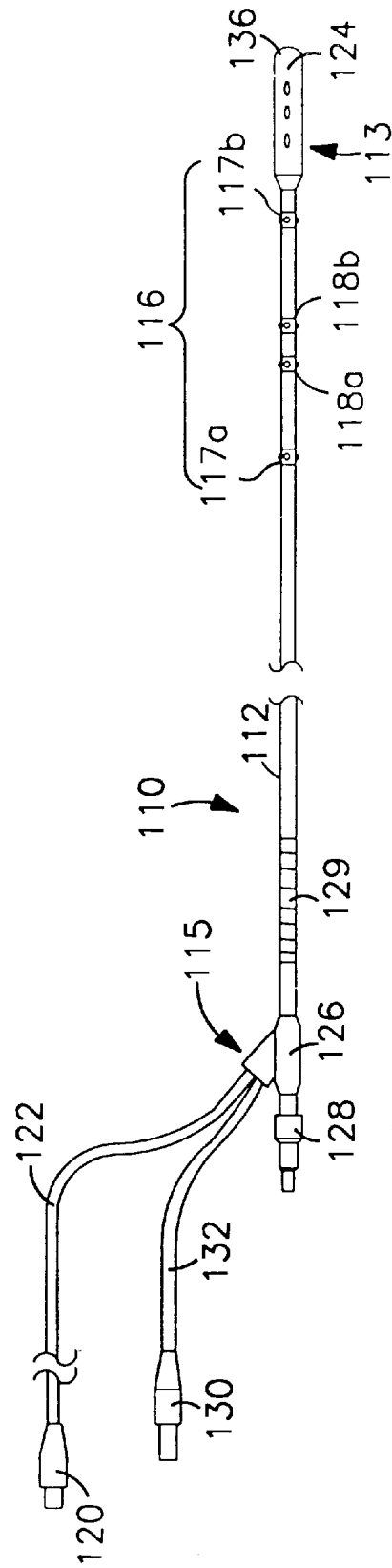

FIG. 16

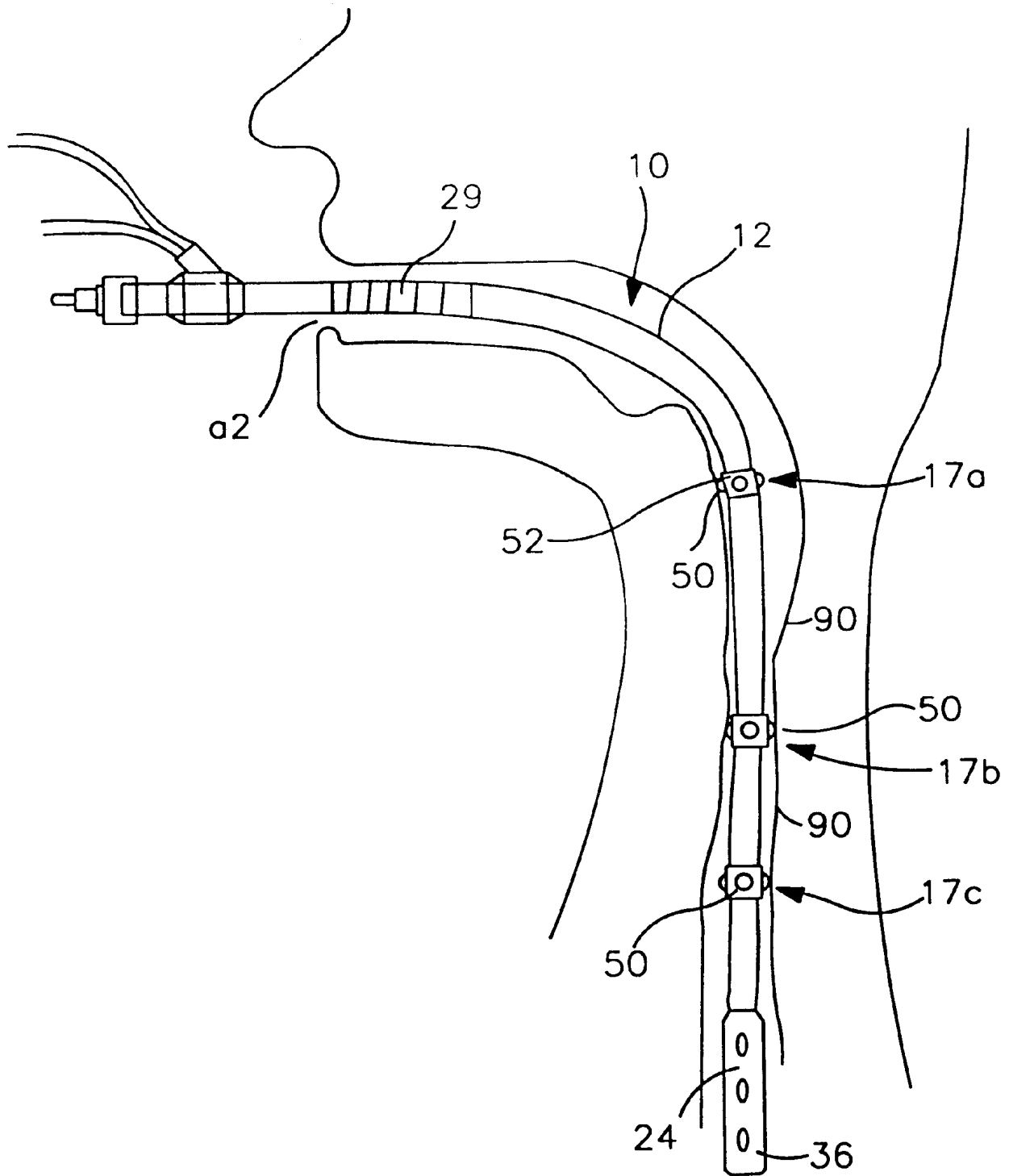

FIG. 15

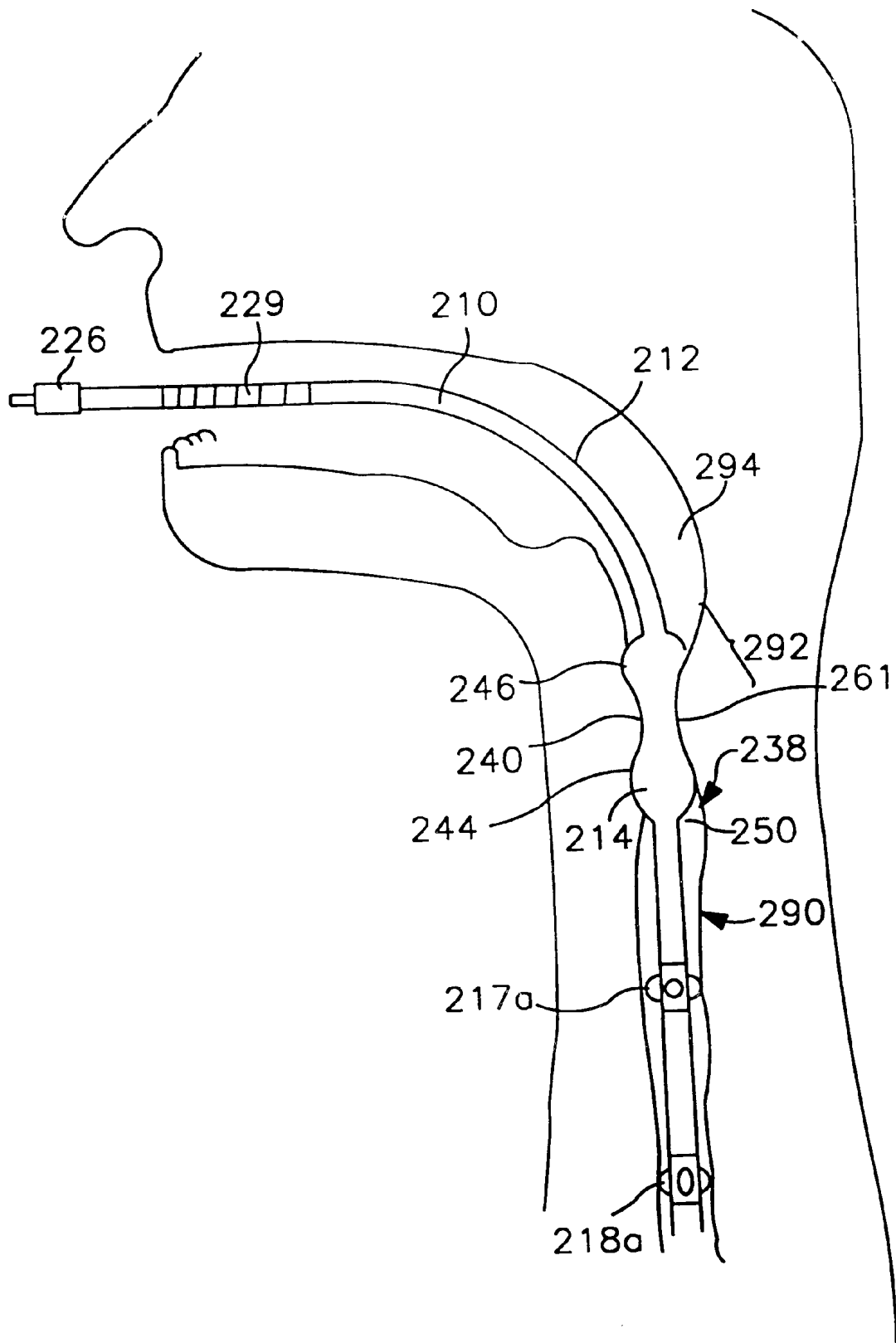

FIG. 17

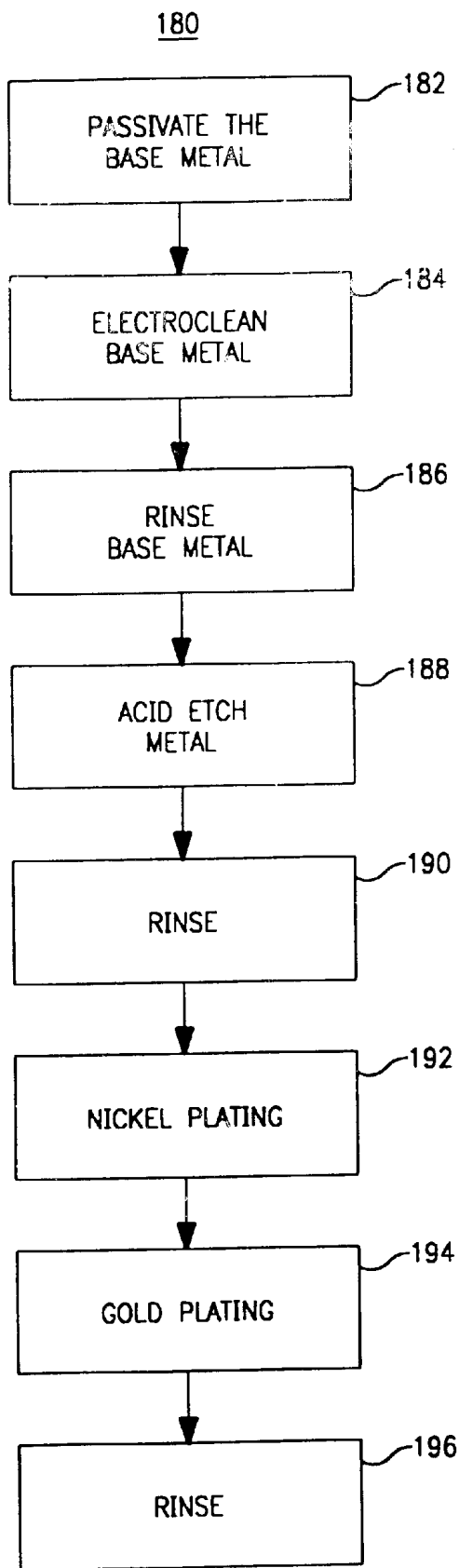

FIG. 18

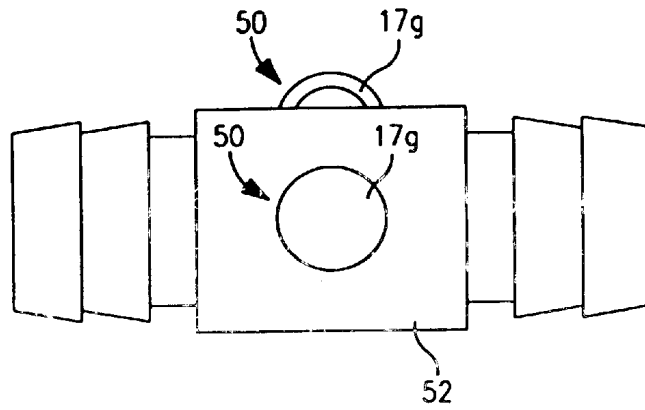

FIG. 19A

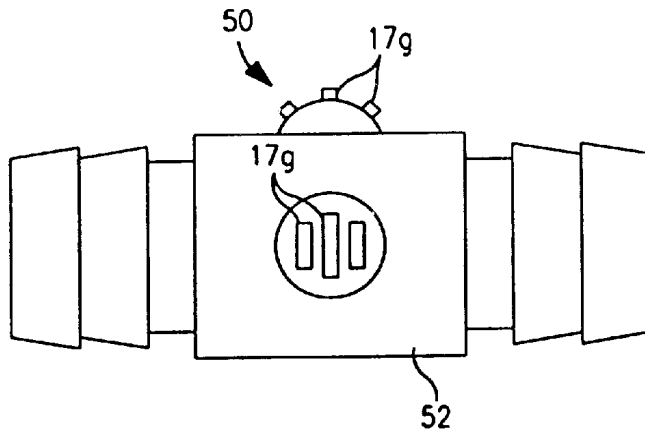

FIG. 19B

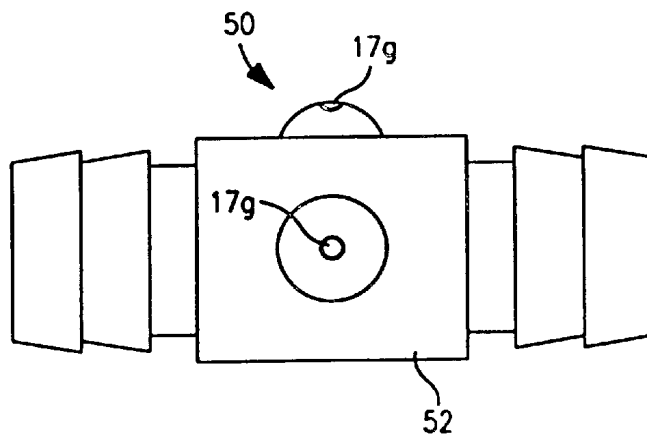

FIG. 19C

ELECTRODE FOR EVALUATING CARDIAC FUNCTIONS VIA ESOPHAGUS

CROSS-REFERENCE TO RELATED APPLICATIONS

This is a continuation-in-part application of U.S. Ser. No. 09/230,666 filed Jan. 29, 1999, now U.S. Pat. No. 6,266,549, which in turn was a National Stage application of PCT Application No. Pct/US98/08271 filed Apr. 24, 1998. Furthermore, this application is a continuation-in-part of prior pending U.S. Ser. No. 09/020,475 filed Feb. 9, 1998, now U.S. Pat. No. 6,322,518, which in turn was a continuation-in-part of U.S. Ser. No. 08/546,246 filed Oct. 20, 1995, now U.S. Pat. No. 5,715,816 issued Feb. 10, 1998, which in turn was a continuation-in-part of U.S. Ser. No. 08/412,287 filed Mar. 28, 1995, now U.S. Pat. No. 5,743,261 issued Apr. 28, 1998, which in turn was a continuation-in-part of U.S. Ser. No. 08/163,052 filed Dec. 6, 1993, now U.S. Pat. No. 5,417,207 issued May 23, 1995, furthermore, this is an application claiming priority on a prior pending Provisional Application, U.S. Ser. No. 60/045,006 filed Apr. 25, 1997 and a prior pending Provisional Application, U.S. Ser. No. 60/067,810 filed Dec. 4, 1997. The subject matter of each of these is incorporated herein by this reference.

TECHNICAL FIELD

The present invention relates, generally, to the evaluation of cardiac functions, and more particularly to the invasive determination of cardiac output and electrical activity via the use of electrodes placed within the esophagus region of a subject.

BACKGROUND OF THE INVENTION

Electrocardiography, or ECG, involving the collection and study of the electrical activity from the heart, has long been an effective method for the diagnosing of problems or irregularities related to the operation of the heart. Generally, ECG is used for two major purposes: (1) for diagnosing cardiac arrhythmia's, and (2) providing information on the status of the myocardium.

The early methods for obtaining an electrocardiogram or ECG included the placing of electrodes invasively through the skin or noninvasively attaching the electrodes to the surface of the patient's skin, such as the chest or limbs, by adhesion or clamping. However, certain anatomical disabilities of the human or animal physiology often obstruct the hearts electrical current from the measurement device and thus cause an inaccurate measurement. To avoid these problems, methods were developed for conducting invasive electrocardiograms via the esophagus.

Esophageal probes for monitoring a patient are, in general known. For example, U.S. Pat. No. RE 31,377, Mylrea et al., reissued Sep. 13, 1983, and U.S. Pat. Nos. 4,349,031 and 4,476,872, Perlin, issued Sep. 14, 1982 and Oct. 16, 1984, respectively, disclose catheters used for monitoring the patients electrocardiogram, heartbeat sounds and temperature. However, disadvantages exist with these probes due to the use of either pill or ring electrodes. Pill electrodes, as shown in FIG. 1A, which are electrodes capable of being swallowed by the patient in an attempt to position the electrodes in the esophagus at the level of the atria, have yielded results that were inconclusive because of variability in electrode placement. Ring electrodes, generally comprised of a conductive band wrapped around the circumference of the probes' flexible tubing, as shown in FIGS. 1B

and 1C, can float within the esophagus, and thus, have also yielded inconclusive results for similar reasoning. In particular, when the electrode is not in contact with the tissue wall of the esophagus directly, a fluid or mucosal connection affects the impedance of the received signals, and thus, detrimentally impacts the diagnostic quality of the signals.

Another example, U.S. Pat. No. 3,951,136, Wall, issued Apr. 20, 1976, also discloses an esophageal probe used for monitoring a patient's cardiac electrical activity, heart sounds and temperature wherein the probe disclosed utilizes a pair of spaced electrodes with domed-shaped outer heads. Although these electrodes purport to provide improved contact surface over previously described electrodes, the disclosed electrodes limit and restrict the rotational position of the probe within the esophagus. Moreover, the electrodes configuration suffers from other inherent design inadequacies, such as, for example, a potentially weak soldered connection to the wiring system. Further, like the other prior art esophageal probes, the distal end of the probe comprises a thin membrane or diaphragm that seals the end of the probe. As one skilled in the art will appreciate, these thin-walled diaphragms, while effective in allowing for temperature and sound measurements to be obtained, are quite fragile and are often damaged during insertion and use within the patient's esophagus.

Other methods for evaluating cardiac functions are known in the prior art. One particular example, impedance cardiography, is increasingly an important mechanism for determining a patient's cardiac condition both during and following medical procedures.

Impedance cardiography falls within the more general category of impedance plethysmography, which refers to the measurement of volume changes (and thereby flow) in the body, as derived from observing changes in electrical impedance. Impedance cardiography, generally, is a noninvasive bioimpedance method for measuring cardiac output. Specifically, cardiac output measurements are based on the principal that blood is a conductor of electricity and that the electrical impedance of the thorax will change during a cardiac cycle. This change in impedance is caused by the thoracic aortic blood flow which is directly related to the amount of blood ejected from the heart.

U.S. Pat. No. 3,340,867, now Re. 30,101, reissued September 1979 to Kubicek, et al., discloses a method for determining cardiac output by measuring the patient's heart stroke volume. There, an impedance plethysmograph employs two sets of electrodes placed on the neck and chests of patients, to provide an impedance difference signal from the two center electrodes. A constant, low-amplitude, high-frequency alternating current is applied to the outermost pair of electrodes while the innermost pair of electrodes senses the voltage levels above and below the patient's heart. Kubicek et al.'s method entails first determining the heart stroke volume from these impedance signals, based on the observation that resistance to a current passed through the chest varies with thoracic aortic blood flow, and from this determination of stroke volume, then estimating the cardiac output.

U.S. Pat. No. 4,450,527, issued to Sramek on May 22, 1984, generally discloses a similar apparatus, model and equation for relating impedance and stroke volume to determine cardiac output. U.S. Pat. No. 5,309,917, issued May 10, 1994, U.S. Pat. No. 5,423,326 issued Jun. 13, 1995, and U.S. Pat. No. 5,443,073 issued Aug. 22, 1995, all of which were issued to Wang, et al., each generally disclose variations of the Kubicek and Sramek methods.

Yet another model and method of impedance cardiography regarding the placement and spacing of electrodes has been proposed by Bernstein. According to Bernstein, stroke volume (SV) is related to the change in impedance (Z) as shown in Equation 1:

$$SV = \frac{\delta \times (0.17 H)^3 \times T_{LVE} \times (dZ/dt)_{\max}}{4.2 \times Z_0} \quad (1)$$

SV	= Stoke Volume
δ	= correction factor for patient weight
H	= Patient height (cm)
T_{LVE}	= left ventricular ejection time (sec)
$(dZ/dt)_{\max}$	= maximum value of the first derivative of Z, where Z is the change in impedance caused by thoracic aortic blood flow
Z_0	= mean baseline impedance of the thorax (ohm)

While each these methods can be helpful in determining cardiac output, the various types of non-invasive devices disclosed such as the outer skin electrodes of Kubicek and Sramek, often prove inefficient, for example when dealing with many surgical procedures or with skin abrasion patients. As one can imagine, these devices require a number of exposed connective wires and corresponding electrodes that may interfere with other surgical procedures. Furthermore, because the inner surface electrodes may receive impedance signals from various other regions within the patient due to the distance in placement of the electrodes from the thoracic aorta region, accuracy concerns have been raised. Additionally, incorrect electrode placement can result due to the changes in the patient's physiology of the thorax with respect to the placement of the electrodes on the sternum, as well as due to the size of the patient. Finally, as recognized in Equation 1, a correct factor for patient weight, δ , must be utilized in calculating cardiac output, and often if the weight cannot be accurately determined, the weight estimation can be another source of inaccuracy.

Several of the problems with prior art non-invasive devices have been addressed by more recent developments; however, these new developments still fall short in many critical areas. For example, U.S. Pat. No. 4,836,214, issued to Sramek on Jun. 6, 1989, generally relates to an esophageal probe comprised of an array of electrical bioimpedance ring electrodes provided on a hollow, flexible tube that is inserted into the esophagus of a patient and positioned proximate the descending thoracic aorta. The Sramek device, however, like other non-invasive prior art probes, still permits movement of the probe within the esophagus. As a result of this motion, artifact inaccuracies are possible. This problem is further attenuated by the use of the ring electrodes in that such electrodes often tend to float within the esophagus, as stated previously above.

U.S. Pat. No. 5,357, 954, issued to Shigezawa et al. on Oct. 25, 1994, generally relates to an esophageal blood oxygen saturation probe with temperature and sound sensing devices for invasively monitoring a patient. The patent discloses that the internal walls of the esophagus will tend to collapse onto the outer surface of the probe's chassis and sound sensor, such that the probe's sensors will not move appreciably with respect to the esophagus. The ability of the esophagus to prevent undesirable movement of the probe as so disclosed, particularly given the size of the probe, is questioned. Nevertheless, because the probe is not substantially fixed relative to the esophagus, there still exists an opportunity for undesirable movement which, as will be

appreciated by those skilled in the art, can lead to inefficient and less accurate results.

Motion limiting devices such as those disclosed in prior oximetry work of the present assignee are known; however, heretofore these teachings have not been used in cardiac evaluations, such as impedance cardiography applications. In this regard, the subject matter of application Ser. No. 60/045,006, application Ser. No. 09/020,475, application Ser. No. 08/546,246 (U.S. Pat. No. 5,715,816), application Ser. No. 08/412,287 (U.S. Pat. No. 5,743,261) and application Ser. No. 08/163,052 (U.S. Pat. No. 5,417,207) are incorporated herein by reference.

In addition, many surface or skin electrodes used for evaluating cardiac functions and other bio-potential measurements utilize electrolytes to improve the electrical conductivity between the electrodes and the patient at the point of contact, such as between the electrodes and the patient's skin. These surface electrodes typically use electrolyte gels to improve the electrical conductivity. However, while these electrolyte gels provide associated benefits, it should be noted that these electrolytic interfaces may cause a difference in voltage potentials to be applied between the ECG electrodes. For example, while a typical signal as used for ECG equipment may be approximately 1 mV peak-to-peak, and while the instruments for conducting the ECG measurements are generally configured for signals of no more than 5 mV peak-to-peak, it is possible for electrolytic junctions to build up or develop a DC bias voltage of hundreds of millivolts. Accordingly, it is desirable that the voltage difference between electrodes, i.e., the difference potential or DC bias voltage, be minimized in order to limit the tolerance for input offset voltage required by the ECG equipment. Moreover, the ECG equipment must be configured to tolerate the difference potential to, in effect, remove the detrimental features of the difference potential (DC bias voltage) from any ECG signals prior to displaying the results.

To minimize and delay the build up of these difference potentials, current standards for ECG and other bio-potential measuring equipment, such as ANSI EC13 standards, attempt to limit the allowable electrode-to-electrode currents. Typically, these standards require at least a ± 300 mV bias voltage tolerance capability for ECG and other bio-potential measuring equipment. Moreover, it is not uncommon for older ECG and other bio-potential measuring equipment still in use to have a limited tolerance of approximately ± 150 mV of bias voltage during operation.

Electrodes configured for internally evaluating cardiac functions and other bio-potential measurements can utilize naturally occurring electrolytes present within the anatomical canal of a patient to improve the electrical conductivity at the point of contact. For example, with respect to esophageal type electrodes, saliva and gastric fluids within the esophagus of the patient can provide the electrolytes that facilitate enhanced electrical conductivity between the electrodes and the esophageal wall or other internal regions of the patient. However, as a result of these electrolytes being present at the point of contact, problems can arise if there is an increase in the difference potential between electrodes, i.e., relatively large voltage difference potentials may be created at the point of contact between the electrode and the patient as a result of the electrolytes present within the esophagus of the patient. Accordingly, the corresponding magnitude of the difference of these voltage potentials must be tolerable to the ECG and other bio-measurement equipment. In other words, the difference potential must be tolerated by the input channel of the ECG measuring equipment and thus, should be minimized below 300 mV for new equipment and 150 mV for older equipment.

In addition to the above, other causes for difference potentials exist within the ECG equipment. For example, for many esophageal electrodes a small DC current is often provided between sensing electrodes to facilitate “lead off” detection. “Lead off” detection is the identification of whether the electrodes are suitably “in contact” with the patient’s esophageal wall, typically through the use of a small current transmitted between electrodes. This small DC detection current can approach 1 μA in many instances. However, due to the presence of electrolytes, a capacitive charge may build up at the electrode’s point of contact, to provide, in essence, an electrolytic capacitor. While limiting the DC detection current, such as to approximately 0.1 μA , can slow the rate and ultimate magnitude of the charge at the electrodes, the resulting electrolytic charge can still operate to increase the difference potential between electrodes.

Thus, there exists a long felt need, for an electrode configuration, such as for use in connection with an esophageal probe, which addresses the various deficiencies of the configurations shown in the prior art as discussed herein, including, among other things, inaccurate readings, difficulty in manufacture, reliability in use, fragile construction, and the like. Moreover, there exists a long felt need for an esophageal probe to provide electrodes that remove the variability of electrode placement and contact and provide a concise method of measurement from the esophagus region. Further, there exists a need for electrodes that minimize the detrimental effects of large voltage difference potentials at the point of contact with the patient, such as those differences in voltage potential that may be caused by electrolytic activity present within the esophagus region. Additionally, there exists a need for an esophageal probe that can obtain sound and temperature measurements while evaluating various cardiac functions without the potential for becoming damaged during insertion and use within the patient’s esophagus.

SUMMARY OF THE INVENTION

An electrode according to the present invention addresses many of the shortcomings of the prior art.

In accordance with the present invention, an electrode useful for generating or receiving electrical signals generally comprises a base and more than one dome-like protuberance arranged on an exterior surface of the base. Further, the electrodes may include connectors configured to enable attachment to a probe for insertion into an anatomical canal of a human or animal.

In accordance with one aspect of the present invention, an electrode assembly may be suitably disposed on an elongated, flexible chassis. The chassis is suitably configured for insertion into the esophagus of a patient. Furthermore, the electrode assembly includes the dome-like prominent-arena electrodes for the delivery of alternating current and the sensing of voltage abstract associated with a corresponding impedance variation of the thorax of a patient for determining cardiac output or alternatively for the receiving of electrical signals from the heart (i.e. ECG).

Still further, in accordance with another aspect, the electrodes may be configured with a gold-plated layer to minimize differences in voltage potential present at the point of contact between the electrodes and the patient, such as those difference potentials that may be caused by electrolytic activity. These gold-plated electrodes may comprise dome-like prominent-arena electrodes or ring electrodes and the like.

In accordance with a further aspect of the present invention, the probe is suitably configured for insertion in

the esophagus. In an exemplary embodiment, the probe may also include a deployment device suitably configured as a crico-pharyngeal (“CP”) “lock” which substantially secures the probe and the prominent-arena electrodes within the esophagus, greatly minimizing probe movement and enhancing the accuracy of measurement of bioimpedance signals. The CP lock also serves as an esophageal dioptr which serves to prevent fluids and other matter from passing-up and being aspirated by the patient.

In accordance with a further aspect of the present invention, the probe is suitably configured to include a temperature measuring device and an acoustic diaphragm for additional monitoring capabilities.

BRIEF DESCRIPTION OF THE DRAWING FIGURES

The present invention will be hereinafter described in conjunction with the appended drawing figures, wherein like designations denote like elements, and:

FIG. 1A is a side view of a pill electrode of the prior art;

FIG. 1B is an end view of a ring electrode of the prior art;

FIG. 1C is a side view of a ring electrode of the prior art;

FIG. 2 is a side view of an electrode in accordance with the present invention;

FIG. 2A is an end view of the electrode of FIG. 2 taken along the lines A—A of FIG. 2;

FIG. 2B is a cross-sectional view of the electrode of FIG. 2 taken along the lines B—B of FIG. 2;

FIG. 3 is a cross-sectional view of a further embodiment of an electrode in accordance with various aspects of the present invention;

FIG. 4 is a cross-sectional view of yet a further embodiment of an electrode in accordance with various aspects of the present invention;

FIG. 5 is a cross-sectional view of a still further embodiment of an electrode in accordance with various aspects of the present invention;

FIG. 6A is a side view of a still further embodiment of an electrode in accordance with the present invention;

FIG. 6B is a side view of yet another embodiment of an electrode in accordance with the present invention;

FIG. 7 is a side view of an electrode in accordance with the present invention which includes an alternative embodiment attachment mechanism;

FIG. 8A shows a top view of an electrode assembly of the present invention illustrating an alternative attachment mechanism.

FIG. 8B is a side view of the electrode assembly of FIG. 8A;

FIG. 9 shows an alternative configuration of the electrode of FIG. 8A in accordance with the present invention;

FIG. 10 is a side view of an alternative configuration of the electrode of FIG. 2 in accordance with the present invention;

FIG. 11 is a top view of a probe in accordance with one embodiment of the present invention;

FIG. 12 shows a schematic representation of an electrode assembly in accordance with the present invention;

FIG. 13 shows a schematic representation of a temperature measuring device in accordance with the present invention;

FIG. 14 is an alternative configuration of the probe in accordance with the present invention;

FIG. 15 shows a schematic representation of the probe of FIG. 2 within an anatomical canal (e.g. the esophagus) of a patient;

FIG. 16 is a top view of an alternative embodiment of an exemplary probe in accordance with the present invention;

FIG. 17 shows a schematic representation of the probe of FIG. 15 within an anatomical canal (e.g. the esophagus) of a patient;

FIG. 18 shows an illustrative process for providing a gold-plated layer onto an electrode in accordance with the present invention; and

FIGS. 19A–C shows a side view of additional embodiments of an electrode in accordance with the present invention.

DETAILED DESCRIPTION OF PREFERRED EXEMPLARY EMBODIMENTS

While the way in which the present invention addresses the disadvantages of the art will be described in greater detail hereinbelow, in general, the present invention provides a novel electrode having a configuration which affords many advantages over prior art configurations. As noted hereinabove, conventional ring electrodes are unsatisfactory for most applications in that they exhibit the tendency of being susceptible to errors due to, inter alia, motion artifact and the like. Attempts to address these disadvantages, such as the provision of domed shaped electrodes, for example of the type shown in the Wall '136 patent, are unsuitable because, inter alia, such configurations are susceptible to possible destruction or distortion of the signal due to the multi-component nature of the electrode and/or the inability of properly positioning the electrode within an anatomical canal to generate and/or receive appropriate electronic signals.

Therefore, in accordance with the present invention, and with reference to FIG. 2, the electrodes 17 useful in the context of the present invention preferably include more than one arena electrode dome 50 suitably arranged on a unitary base 52. Preferably, as shown in FIGS. 2, 2A and 2B, base 52 comprises an annular ring having an aperture 54 passing therein. As shown best in FIG. 2B, electrode domes 50 are integrally formed with ring 52, such that when used in connection with a probe configured for insertion into an anatomical canal of a human or animal, anatomical fluids are prevented from penetrating the juncture between dome 50 and ring 52. While in certain applications and aspects of the present invention such a unitary construction may not be necessary, in accordance with a preferred embodiment of the present invention, such construction addresses various of the shortcomings of prior art configurations.

In accordance with the present invention, dome(s) 50 and ring 52 are suitably comprised of a metal substrate with a desired hardness and corrosion resistance to provide durability. Preferably, dome 50 and ring 52 are comprised of a homogeneous metal that is effective in stabilizing the negative impact in signal quality that can result through the use of metals that are inherently unstable, e.g. an unstable metal can cause the dome 50 and ring 52 to develop different polarities which can lead to inaccurate measurements. In accordance with an exemplary embodiment, dome 50 and ring 52 may be comprised of a type 316 stainless steel which has proven durability and corrosion resistance qualities.

As discussed above, large difference potentials between electrodes which may be created at the point of contact can cause problems with the ECG and other bio-measurement. For example, the difference potential for electrodes having

a silver or nickel alloy outer surface, or a stainless steel outer surface can exceed the 150 mV bias voltage limit that is common for older ECG and bio-potential measurement equipment, and can often approach the 300 mV limit standards of new equipment. Accordingly, a need exist for electrodes that are configured to minimize the magnitude of the difference potential at the point of contact.

In accordance with one aspect of the present invention, it has been discovered that by providing an electrode with a suitably configured gold-plated layer which serves as an interface with the patient while the electrode is being exposed to electrolytes, the difference in voltage potential between electrodes can be greatly reduced. In accordance with this aspect, the gold-plated layer suitably comprises a layer of gold-like material of a thickness and weight such as may be utilized for the plating of electrical contact pins and terminals used in electrical circuit applications.

In accordance with a preferred embodiment of the present invention, the layer of gold-plating may be configured with an electrode 17 having a dome 50 and ring 52. For example, dome 50 and ring 52 may further include a gold-plated layer 17a. In an exemplary embodiment, gold-plated layer 17a is suitably configured on the outer surface of dome 50 and ring 52. For example, gold-plated layer 17a may encapsulate a homogeneous metal that comprises dome 50 and ring 52, or any other material comprising dome 50 and ring 52. However, as will be described below with reference to FIGS. 19A through 19C, gold-plated layer 17a may also be configured to encapsulate only dome 50 (FIG. 19A), or any portion of dome 50 (FIGS. 19B and C).

As a result of gold-plated layer 17a being configured on the outer surface of dome 50, it has been discovered that the magnitude of the difference in voltage potential at the point of contact, such as that caused by the electrolytic activity, can be suitably reduced below the 150 mV limit. In many instances, the magnitude of the difference in voltage potential can be reduced to approximately 70 mV, safely below the bias voltage limitations. Accordingly, electrode 17 can facilitate a more stable and accurate bio-potential reading of the patient during the conducting of ECG and other bio-potential measurements.

Gold-plated layer 17a suitably comprises a layer of gold of a varying amount of thickness and weight for plating, depending on any number of different design criteria. For example, gold-plated layer 17a may comprise a thickness and weight similar to that used for electrical contacts or terminals in various types of electrical circuits, or any other suitable thickness. Preferably, gold-plated layer 17a comprises a thickness between about 0.3 μm and about 6.0 μm , and more preferably between about 0.5 μm and about 1.5 μm . Moreover, the composition of gold-plated layer 17a may comprise a variety of mixtures of gold, for example, from approximately pure gold metal to an alloy having less than 20% gold by weight. Still further, gold-plated layer 17a may be configured to provide the entire structure of dome 50, or dome 50 and ring 52, e.g., dome 50 and ring 52 may be comprised entirely of gold or a gold mixture, without the use of another homogeneous metal base.

Although the encapsulating of substantially the entire outer surface of dome 50 may be preferable, gold-plated layer 17a may be configured in various other arrangements. As discussed above, gold-plated layer 17a may be configured to encapsulate dome 50, or dome 50 and ring 52. In addition, gold-plated layer 17a may be configured to encapsulate only a portion of dome 50. For example, with reference to FIG. 19, gold-plated layer 17a may be suitably

arranged in various manners to cover a portion of the outer surface of dome **50**, such as a plurality of segments (FIG. **19B**), or as a gold tip arranged on or within the center of the outer surface of dome **50** (FIG. **19C**). Accordingly, gold-plated layer **17a** may be suitably arranged in any manner that is configured to minimize the magnitude of the difference in voltage potential between any two electrodes.

In accordance with another aspect, gold-plated layer **17a** may be suitably applied in a variety of manners to a homogeneous metal base, such as stainless steel. One such method for applying gold-plated layer **17a** may include an electroplating process similar to that used to manufacture gold-plated electrical contacts and terminals for high reliability electrical connections. For example, with reference to a process **180** as illustrated in FIG. **18**, a homogeneous metal base, such as stainless steel, may be passivated in a step **182** to provide an thin, insoluble film on the outer metal surface. This passivation step **182** may be accomplished in various manners, such as by nitric acid or any other oxidizing acid and the like. Thereafter, in a step **184**, the metal base may be suitably electrocleaned, such as through the use of a heated caustic solution, and then rinsed in a step **186**. After electrocleaning, the metal base may be suitably etched in acid in a step **188**. This acid etching step **188** may comprise conventional methods for etching of metals. After etching, the metal base may be suitably rinsed in a step **190** prior to electroplating.

Continuing in accordance with this illustrative process for electroplating, the metal base may be suitably plated in a step **194** with a gold-layer of material, such as gold-plated layer **17a**. This plating step **194** may comprise conventional electroplating processes to suitably provide a gold-plated layer thickness between about $0.3\ \mu\text{m}$ and about $6.0\ \mu\text{m}$. In accordance with another aspect, illustrative process **180** may also include a nickel plating step **192** prior to gold-plating step **194**. In accordance with this aspect, a nickel-plated layer having a thickness between $3.0\ \mu\text{m}$ and $6.0\ \mu\text{m}$ may be suitably electroplated to the metal base prior to the electroplating of the gold layer in step **194**. Moreover, after applying the nickel-plated layer in step **192**, a gold-plated layer of between $0.5\ \mu\text{m}$ and $1.5\ \mu\text{m}$ may be suitably applied to the metal base through electroplating in step **194**. Thereafter, regardless of whether a nickel-plating step **192** is provided, the electroplated metal base may be suitably rinsed in a step **196** to complete the gold-plated electroplating process **180**.

Although the illustrative process **180** provides various processing steps, it should be noted that such steps may be modified or alternated in various other manners without departing from the scope of the present invention. For example, rinsing steps **186**, **190** and **196** may occur on a more frequent basis, such as immediately after passivation step **182**, during electrocleaning step **184** or acid etching step **188**, or may include only one occurrence of such rinsing steps, such as at the end of process **180**. Moreover, various types of oxidizing, non-oxidizing and caustic acids and solutions may be utilized to provide a gold-plated layer on an electrode in accordance with the present invention, and those described above are merely for illustrative purposes. Further, it should be noted that any method for providing electroplating of gold-plated layers to a homogeneous metal, now known or hereinafter devised, may be utilized in accordance with the present invention.

It should be noted that although a dome-like configuration is discussed above, various other configurations of electrodes may be suitably configured with a gold-plated layer to minimize the difference in voltage potential that may be

caused by electrolytes, such as those electrolytes provided through a gel applied to an outer surface of a patient or those provided by naturally occurring gastric juices, saliva and the like. For example, gold-plated layer **17a** may be suitably configured on conventional ring electrodes, or configured on ring electrodes having dome-like protuberances as are described below.

With continued reference to dome-like electrodes illustrated in FIGS. **2**, **2A** and **2B**, dome **50**, with or without gold-plated layer **17a**, preferably has a radius of curvature in the range of $0.050''$ to $0.090''$, and more preferably in the range of $0.065''$ to $0.070''$ for use in connection with most human and animal esophageal probes. Such a configuration enables the dome to have a sufficiently large surface area. The present inventors have found that domes of such a configuration enhance the reliability of signal data that can be obtained through use of such electrodes. That is, electrodes **17** including domes **50**, particularly more than one dome **50**, have increased surface area as compared to more conventional ring-type electrodes. As a result, electrodes **17** are better suited for receipt of or sending of signals to or from electrodes **17**.

As previously mentioned, electrode **17** preferably includes more than one dome **50**. As shown in FIGS. **2A** or **2B**, a preferred embodiment of electrode **17** includes three electrode domes **50** symmetrically spaced about the circumference of ring **52**. As those skilled in the art will appreciate, however, various other configurations are possible. For example, one and one-half domes to more than three domes can be utilized in the context of the present invention. Thus, electrode **17** may also be suitably configured in the form of electrode **17A** to include two domes **50** (as shown in FIG. **3**), or in the form of electrode **17B** to include four domes **50** (as shown in FIG. **4**) or five domes (as shown in FIG. **5**). As one skilled in the art will appreciate, the number of domes **50** for each electrode **17** is not limited in any manner.

As will be discussed in greater detail herein, the number, configuration and placement of domes **50** about the exterior surface of ring **52** may be selected depending upon any number of factors. For example, as the number of domes **50** about the circumference of ring **52** increase, the user is provided with greater accuracy in positioning electrode **17** within the particular anatomical canal. Stated another way, and as will be described in connection with a preferred embodiment of the present invention set forth below, when electrodes **17** are used in connection with an ECG or cardiac output probe, the incorporation of multiple domes **50** enable enhanced signal reception and quality.

Preferably, as shown in FIG. **2**, electrodes **17** are configured such that when observed from a top perspective view, dome **50** exhibits a generally circular dome shape. It should be appreciated, however, that other shapes, sizes or dimensions may be utilized. In accordance with one aspect of the present invention, dome(s) **50** may exhibit any configuration or shape which either enhances the available surface area of electrode **17** and/or enhances the ability of electrode **17** to contact the wall of the anatomical canal into which it is inserted. Thus, dome **50** may also be configured in various other shapes and/or configurations, including, for example, respective horizontal ellipses **50a** or respective vertical ellipses **50b**, as shown in FIGS. **6A** and **6B**. Moreover, dome **50** may include such a vertical ellipse **50b** that is configured substantially around the outer circumference of ring **52**. As one skilled in the art will appreciate, the available configurations in the shape of dome **50** are not limited in any manner.

In accordance with the present invention, electrode **17** is suitable for attachment to a probe which is configured for

insertion into a human or animal anatomical canal. In accordance with various aspects of the present invention, electrode 17 is suitably configured for attachment to or into such a probe. While various probe embodiments of the present invention will be described in greater detail, hereinbelow, in accordance with one aspect of the present invention, electrode 17 is configured to be attached within a multi-segment probe. For example, with reference to FIG. 2, electrode 17 may suitably comprise a first connector 55a and a second connector 55b located on opposing sides of ring 52. In accordance with this aspect, connectors 55a and 55b are also suitably configured to include an aperture 54 in alignment with aperture 54 of ring 52 (see FIG. 2). Connectors 55a and 55b are suitably configured to enable attachment of electrode 17 to a tube-like probe. While any variety of connection mechanism may be used, in accordance with one embodiment, and as shown in FIG. 2, connectors 55a, 55b are comprised of respective barbs 56a and 56b suitably configured to facilitate connection of electrode 17 to a chassis. Further, in accordance with a particularly preferred aspect, barbs 56a and 56b include multiple components or levels to suitably embed connectors 55a and 55b within a probe.

While in FIG. 2 two such "levels" are shown, it should be appreciated that any number of levels can be utilized. Alternatively, with reference to FIG. 7, instead of connectors 55a and 55b respective threaded sections 57a and 57b may be employed to facilitate connection of electrode 17 to a probe. Further, as one skilled in the art will appreciate, connectors 55a and 55b may also be comprised of various other press-fitting devices and the like to suitably facilitate connection of electrodes 17 to a probe. Still further, various other methods and devices, including, for example, use of adhesives or molding or snap-fitting connectors or any like manner may be utilized in the context of the present invention. As one skilled in the art will appreciate, the attachment devices or methods for connecting electrodes 17 to the probe is not limited in any manner.

In addition, first connector 55a and second connector 55b may comprise the same material as dome 50 and ring 52, such as stainless steel or any other homogeneous metal. Further, first connector 55a and second connector 55b may comprise a different material than dome 50 and ring 52. In accordance with an exemplary embodiment, first connector 55a and second connector 55b include a gold-plated layer 17a, i.e., the entire outer surface of electrode 17 or portions thereof, including dome 50, ring 52 and first connector 55a and second connector 55b, may be provided with gold-plated layer 17a.

Referring now to FIGS. 8A and 8B, and in accordance with another aspect of the present invention, electrode 17 may suitably comprise a band 70 having a first end 71a, a second end 71b, an outside surface 73, and a dome 74. In accordance with this aspect of the present invention, first end 71a and second end 71b each are suitably provided with respective slots 72a and 72b, designed to enable circumferential attachment of band 70 to a probe. In this fashion electrodes may be attached to, as opposed to being imbedded within, a portion of the probe. Band 70 may be either conductive or non-conductive; however, enhanced signal reception is generally available when band 70 is conductive.

Dome 74 is suitably configured to provide electrode 70 with an outer surface to facilitate and maintain direct contact with the esophagus region. In accordance with this preferred aspect, outside surface 73 may be comprised of a plastic-like substrate through which dome 74 comprising a metal material extends. Alternatively, dome 74 may be produced by a

mechanical punch formed from outside surface 73 which comprises a metal substrate, or contact surface 74 may be suitably formed and then attached to outside surface 73 of band 70 by any other means, such as, for example, by direct soldering to outside surface 73 of band 70.

Various modifications of this connectable band-type electrode will be readily discoverable to those skilled artisans in light of the disclosure thus provided. For example, with reference now to FIG. 9, band 70 may include a plurality of domes 74 such as, for example, three domes as shown. As one skilled in the art will appreciate, the number of domes in this preferred embodiment is not limited in any manner. Additionally, as is also shown in FIG. 9, alternative band attachment configurations may be utilized, such as, for example, by providing band 70 with a slot 75 and angled tab section 76, the insertion of tab 76 into slot 75 which facilitates circumferential attachment of band 70 to a probe. It should be appreciated that bands 70 may be formed in other configurations or attached to a probe in other manners, as is now known or hereafter devised by those skilled in the art.

In addition, dome 74 and outside surface 73 suitably comprise a homogeneous metal, such as that of dome 50 and ring 52. Preferably, dome 74 and outside surface 73 suitably include a gold-plated layer 17a as described above that facilitates the minimization of the difference in voltage potential caused by electrolytic activity at the point of contact.

In accordance with another aspect of the present invention, with reference to FIG. 10, an electrode 17d may be suitably configured to be locatable on the distal end of a probe. Such probes may be more suitable for insertion into the esophagus of a patient. Accordingly, electrode 17d configured for end-attachment preferably includes an end 59 which comprises a generally rounded-portion 58. In this embodiment, due to the durability and hardness of portion 58, the risk of damage to the distal end of the probes, as compared to various prior art probes, may be reduced. Further, electrode 17d may be comprised of a plurality of domes 50, such as is shown in FIG. 9, or alternatively a shown in FIGS. 3, 4 and 5 and previously described herein.

In accordance with the present invention, electrode 17 can be utilized in a variety of applications as will in light of the disclosure herein provided as are now known or may hereafter be devised by those skilled in the art. For example, electrodes of the present invention can be utilized in connection with various ECG, cardiac output or other probe applications.

Referring now to FIG. 11, in accordance with a preferred embodiment of the present invention, an exemplary probe assembly 10 suitably comprises a chassis 12 having a distal end 13 and a proximal end 15, and an electrode assembly 16. Preferably, electrode assembly 16 is comprised of one or more electrodes 17. In accordance with this preferred embodiment, probe 10 is preferably utilized for electrocardiography or ECG. Accordingly, electrode assembly 16 is suitably interfaced with an electrode plug assembly 20 which is suitably configured for interaction with an electrocardiogram monitor (not shown). Electrode plug assembly 20 may be advantageously attached to chassis 12 via a cable guide 26 which securely grasps an electrode cable 22, and thus, provides a sealed strain relief for connection of electrode cable 22 to corresponding one or more prominent-arena electrodes 17. For purposes of illustration, in this embodiment electrode assembly 16 includes respective electrodes 17a, 17b, and 17c.

13

As shown, such an exemplary probe assembly **10** may also include other features. In this regard, momentary reference is made to FIGS. **12** and **13**, each of which show, as will be described, the orientation of such components. For example, probe **10** preferably may include, in addition to the aforementioned elements, a temperature measuring device **36** and a functional diaphragm **24**, and/or various combinations thereof. As shown best in FIGS. **11** and **13**, temperature measuring device **36** may be suitably attached to probe **10** proximate distal end **13**. Preferably, device **36** comprises a thermistor, preferably of conventional configuration and design, and, as will be appreciated by those skilled in the art, is useful in determining internal body temperature of the patient. With continued reference to FIG. **13**, preferably thermistor **36** is suitably attached to a connector **30** for interface with a monitor (not shown) via respective cable sections **32** and **34**. As shown best in FIG. **10**, preferably section **34** is placed inside of chassis **12**, while section **32** preferably, extends exteriorly of chassis **12**; preferably, sections **32** and **34** are integrally connected.

Referring now to FIG. **12**, electrodes **17a** and **17b** and **17c** or **17d** are suitably connected to electrode wires, **19a**, **19b** and **19c**, respectively. Preferably, this connection to the electrode wires is by soldering. Furthermore, each electrode wire **19** is fed through chassis **12** and into cable guide **26** for further attachment to electrode cable **22**. In accordance with a particularly preferred aspect of this preferred embodiment, each electrode wire may be spiral wound into chassis **12**. Furthermore, electrode wires are located within cable **22** which suitably provides a biocompatible sheath for further protection.

With continued reference to FIG. **11**, a functional diaphragm **24** may also be provided, and in accordance with this embodiment is located at distal end **13**. Functional diaphragm **24** is preferably configured to serve as an acoustic monitor, and thus, is preferably comprised of a thin acoustic material which allows for the efficient transmission of acoustic signals through chassis **12** and into an acoustic adapter **28** located about proximal end **15** of probe. As shown best in FIG. **11**, acoustic adapter **28** is suitably mounted on proximal end **15** of probe **10** to interface with a standard medical microphone (not shown). In addition, diaphragm **24** is suitably configured to house thermistor **36** and to seal distal end **13** of probe **10**.

In accordance with another embodiment of the present invention, functional diaphragm **24a** may also be suitably positioned at various locations about the length of probe **10**. For example, as shown in FIG. **14**, a probe **10** may include a diaphragm **24** positioned between an electrode **17a** and a distal electrode **17d**, and preferably between respective electrodes **17a** and **17b**. In probe **10A** of FIG. **14**, elements similar to that of probe **10** shown in FIGS. **11**–**13** are designated by the same numeric or alphanumeric designation. In accordance with this embodiment, distal electrode **17d** facilitates the insertion of probe **10** into the esophagus region with less risk of damage than the probes of the prior art. Further, in accordance with this aspect, thermistor **36** and cable section **34** are suitably configured to be housed within the newly positioned diaphragm **24**.

In accordance with the above-described embodiments of the present invention, chassis **12** is suitably configured to be removably inserted into an anatomical canal (e.g. the esophagus) of a human or animal. Chassis **12** is suitably made from any desired biocompatible material, for example, polyurethane, polyethylene, PVC, PTFE, and/or the like. In accordance with a particularly preferred embodiment, chassis **12** is suitably comprised of a flexible resiliency to minimize the danger of lacerating the esophagus during insertion.

14

Preferably, chassis **12** is of sufficient length to position the various components thereon at optimal positions within the esophageal or other anatomical cavity. In accordance with various aspects of the present invention, chassis **12** evidences a length in the range of about 25 to about 75 cm, and preferably in the range of about 45 to about 65 cm, and most preferably in the range of about 52 to about 54 cm.

In accordance with the present invention, probe **10** is preferably configured such that prominent-arena electrodes **17** are positioned to maintain contact with the wall of the anatomical canal into which probe **10** is utilized. With momentary reference to FIG. **15**, for example, when probe **10** is inserted into the esophagus, the preferred configurations of probe **10** enable electrodes **17** to contact with the esophageal wall, generally irrespective of the rotational position of probe **10**.

With reference to FIGS. **11** and **15**, to aid in proper insertion of probe **10**, chassis **12** may include indicia **29** useful for visually determining when probe **10** has been fully and properly inserted into an anatomical canal. Thus, in accordance with a further aspect of the present invention, probe **10** comprises a depth marker **29** which can serve as an indicator as to when probe **10** is inserted a proper distance. Depth marker **29** suitably may be placed on chassis **12** such that when it is at the mouth area, electrodes **17** are deployed within the esophagus region, and acoustic diaphragm **24** and temperature measuring device **36** are in their appropriate locations. Depth marker **29** may comprise indicia, such as markings, surface impressions, etc., formed on chassis **12**. Preferably, depth marker **29** is positioned on chassis **12** a predetermined distance from proximal end **15** in the range of about 7 to about 20 cm, preferably about 10 to about 17 cm, and most preferably about 12 to about 14 cm.

Referring now to FIG. **16**, in accordance with another preferred embodiment of the present invention, an exemplary probe assembly **110** useful for measuring the cardiac output of a patient suitably comprises a chassis **112** having a distal end **113** and a proximal end **115**, and an electrode assembly **116**. Preferably, electrode assembly **116** is comprised of prominent-arena electrodes that include at least a pair of delivery electrodes **117a** and **117b**, and at least a pair of sensing electrodes **118a** and **118b**. Electrode assembly **116** is suitably interfaced with an electrode plug assembly **120** which is suitably configured for interaction with a cardiac output monitor (not shown) serving to deliver a constant, low-amplitude, high frequency alternating current to respective delivery electrodes **117a** and **117b** and receive corresponding voltage signals from respective sensing electrodes **118a** and **118b**.

In accordance with a preferred exemplary embodiment of the present invention, and similar to probe **10** as previously described above, probe assembly **110** may also include other features. For example, probe **10** preferably may include, in addition to the aforementioned elements, a temperature measuring device **136** and a functional diaphragm **124**, and/or various combinations thereof.

With continued reference to FIG. **16**, functional diaphragm **124** may be located at distal end **113**. Alternatively, functional diaphragm (not shown) may be suitably positioned between one or more of electrodes **117** and **118**.

Electrodes **117a** and **117b** and electrodes **118a** and **118b** are suitably configured to be integral with chassis **112** such that probe **110** can deliver alternating current and then detect a voltage abstract associated with an impedance variation of the thorax, with the results measured at a cardiac output monitor (not shown). Preferably, delivery electrode **117a** is

positioned near a mid-region of probe **110** while delivery electrode **117b** is positioned in proximity to distal end **113** of probe **110**. Furthermore, sensing electrodes **118a** and **118b** are positioned in between delivery electrodes **117a** and **117b**, and are spaced approximately equivalent to a patient's heart, to suitably receive the appropriate voltage abstract associated with the impedance variation of the thorax.

In accordance with the present embodiment of the present invention, electrodes **117a**, **117b**, **118a**, and **118b** are suitably comprised of the various embodiments for electrodes as set forth in FIGS. **2** through **8** above and previously described herein. Furthermore, in accordance with the present embodiment, other electrodes, as are now known or hereafter devised by those skilled in the art, may be suitably utilized in probe **10** in accordance with the present invention.

In accordance with the present invention, and as fully disclosed in commonly assigned pending application U.S. Ser. No. 08/546,246, entitled, "Improved Oximeter Probes and Methods for the Invasive Use Thereof", the probe assemblies of the present invention may be suitably configured to ensure that such probes are effectively stabilized within a body cavity. For example, by enlarging the diameter of the chassis **12** or otherwise deploying prominent-arena electrodes **17** and/or **18** of probe **10** into engagement with a wall of the anatomical canal into which the probe is inserted, a certain degree of stabilization may be obtained.

However, in accordance with another aspect of the present invention, the probes disclosed herein may be configured such that the prominent-arena electrodes are positioned and maintained in a region proximate the thoracic aorta. For example, the present inventors have found that locking the probe in a muscular region of a body canal enables the measurement of bioimpedance signals which is relatively unaffected by movements. In accordance with a preferred aspect, the muscle targeted comprises a sphincter-type muscle, such as, the crico-pharyngeal (CP) muscle in the esophagus. As will be appreciated, such sphincter-type muscles function, such as when food or other objects approach the muscle, to contract and dilate thereby allowing the objects to pass. After the objects pass, the muscle again relaxes and constricts.

Thus, in accordance with the various aspects of this embodiment of the invention, the probes disclosed herein may be suitably configured to take advantage of the dilation and constriction of such muscle, e.g. the CP or other similar muscle, to secure and stabilize the probe within the anatomical canal, thus tending to inhibit movement of the probe while obtaining reliable bioimpedance readings. Such a configuration also serves to act as an esophageal dioptr, preventing fluids and other matter from passing up and being aspirated by a patient. The use of deployment devices of this type in connection with esophageal oximetric applications is disclosed in U.S. Pat. No. 5,715,816 issued Feb. 10, 1998, the subject matter of which, as previously noted, is incorporated by reference herein. While the '816 does not describe use of such a device in connection with ECG or cardiac monitors of the type disclosed herein, the present inventors have found that such a device may have usefulness. In view of the incorporation of the subject matter of that reference into this document, the particulars of the deployment device will not herein be described. However, for purposes of illustration, an exemplary probe with use of such a deployment device will now be described. Specifically, referring now to FIG. **17**, and in accordance with a preferred aspect of this embodiment of the present invention, a probe **210** may be provided with a deployment device **214** of the type described in the '816 patent.

To aid in the description of this aspect of the present invention, and with continued reference to FIG. **17**, the use of device **214** will now be briefly described. When a probe **210** including deployment device **214** is inserted into an anatomical canal, e.g. the esophagus, leading edge **250** enters into a muscle region, e.g. the CP muscle region, thereby causing the CP muscle to contract and dilate. This dilation advantageously allows first segment **238** of deployment device **14** to enter the CP muscle region. Continued insertion of the probe, and thus device **14** into the canal, e.g. the esophagus, causes lobe **244** to contract and interact with the CP muscle; through appropriate dimensioning of lobe **244**, such interaction causes the CP muscle to relax and constrict. This constriction together with further insertion of the probe tends to cause the CP muscle to constrict further and substantially surround joining section **240** about region **261**. Further insertion of probe **10** thus tends to be inhibited, in large part due to the appropriate dimensioning of lobe **246**. With further movement inhibited, said pairs of delivery and sensing electrodes are suitably deployed into the esophagus. Lobes **244** and **246** thus prevent deployment device **214** from migrating up or down the esophagus once probe **210** is in place thereby allowing substantially stable bioimpedance measurements.

The various dimensions and configurations of the various surfaces of device **214** may be optimized from that which is disclosed in the '816 patent to aid in utilization of probe **210** including device **214**.

Specifically, it should be appreciated that device **214** suitably may evidence a wide variety of different configurations, providing such configurations also enable proper placement and securing of probe **210** in a suitable region of the anatomical canal in which probe **210** is inserted. Thus, alterations and modifications of the dimensions and configurations of the various segments and regions of device **214** may be made, as will be appreciated or as may be hereafter devised by those skilled in the art in light of this disclosure.

With reference again to FIG. **17**, in accordance with a preferred aspect of this embodiment of the present invention, device **214** is suitably employed in connection with probe **210** such that effective and reliable bioimpedance measurements are obtained when probe **210** is inserted into the esophagus; that is, insertion of probe **210** into the patient results in effective placement of electrode assemblies **17**, **18** proximate the esophagus.

To aid in proper insertion of probe **210**, chassis **212** may include indicia useful for visually determining when probe **210** has been fully and properly inserted into an anatomical canal including a depth marker **229**, as previously described herein, which can serve as an indicator as to when probe **10** is inserted a proper distance.

A preferred manner of inserting probe **210** into a patient will now be described with continued reference to FIG. **17**. In accordance with a preferred embodiment of the present invention, a person (e.g. doctor, technician, etc.) will insert probe **210** through the mouth and into an esophageal cavity **290** of a patient causing the leading edge (not shown) to pass down esophagus **290** to and through the CP muscle region **292**. As probe **210** is further inserted, deployment device **214** is directed toward CP muscle **292**. Because deployment device **214** is larger than chassis **212**, leading edge of deployment device **214** will generally stretch the membrane that precedes (i.e. is above) muscle **292**, thereby causing activation of the neurons in the muscle and thus relaxation (i.e. dilation) of muscle **292**. Continued insertion of probe

210 results in lobe 244 being passed through muscle 292, which in turn tends to cause muscle 292 to contract and generally surround segment 240 of device 214. While insertion of probe 210 may halt at that point, preferably probe 210 is further inserted such that lobe 246 is also passed through muscle 292. In accordance with this aspect of the present invention, to thus set deployment device 214 of probe 210 in place, the direction of probe 210 is thereafter reversed such that lobe 246 backs up through CP muscle 292. Such movement tends to cause CP muscle 292 to relax and constrict upon segment 240. This constriction of muscle 292 tends to "lock" device 214 in place thus tending to deploy said delivery and sensing electrodes in an ideal location. In addition, due to the orientation of the elements of probe 120, once device 214 is suitably positioned, acoustic diaphragm 24 and thermistor 36 will also be suitably positioned further within esophagus 90. This approximate positioning may be evident by alignment of a depth marker 29 within the mouth of the patient.

It will be understood that the foregoing description is of preferred exemplary embodiments of the invention, and that the invention is not limited to the specific forms shown. Various modifications may be made in the design and arrangement of the elements set forth herein without departing from the scope of the invention as expressed in the appended claims.

We claim:

1. An electrode useful for generating or receiving electrical signals, the electrode comprising:
 - a base having an outer circumference;
 - a protuberance unitarily arranged on said base, wherein said protuberance has a radius of curvature in the range of 0.050" to 0.090"; and
 - a gold-plated layer configured on an outer surface of said protuberance and said base.
2. An electrode in accordance with claim 1, wherein said protuberance is configured substantially around said outer circumference of said base.
3. An electrode useful for generating or receiving electrical signals, the electrode comprising:
 - an annular ring base having an exterior surface and an interior aperture;
 - a dome-like protuberance arranged on said exterior surface of said annular ring base, said dome-like protuberance having a radius of curvature in the range of 0.050" to 0.090"; and
 - a gold-plated layer configured on said exterior surface of said annular ring base and on said dome-like protuberance.
4. An electrode in accordance with claim 3, wherein said dome-like protuberance has a radius of curvature in the range of 0.065" to 0.070".
5. An electrode in accordance with claim 3, wherein said dome-like protuberance and said annular ring base comprise a homogeneous metal.
6. An electrode in accordance with claim 3, wherein said dome-like protuberance is integrally formed with said annular ring base, such that when used in connection with a probe configured for insertion into an anatomical canal of a human or animal, anatomical fluids are prevented from penetrating between a juncture defined by said dome-like protuberance and said annular ring base.
7. An electrode in accordance with claim 3, wherein said electrode further comprises an end having a rounded-portion configured for insertion into an anatomical canal of a human or animal.

8. An electrode in accordance with claim 7, wherein said electrode further comprises a connector located on a side opposing said rounded portion and configured to enable attachment of said electrode to a distal end of said tube-like probe.

9. An electrode for evaluating cardiac functions, the electrode comprising:

- an annular ring base having a first connector, a second connector, an exterior surface and an interior aperture, wherein said first and said second connectors are configured to enable attachment of said electrode to a tube-like probe;

- a dome-like protuberance unitarily arranged on said exterior surface of said annular ring base; and

- a gold-plated layer covering said exterior surface of said annular ring base and said dome-like protuberance.

10. An electrode in accordance with claim 9, wherein each of said first and said second connectors comprise at least one barb to facilitate attachment to said tube-like probe.

11. An electrode in accordance with claim 10, wherein each of said first and said second connectors comprise a threaded section to facilitate attachment to said tube-like probe.

12. An electrode useful for generating or receiving electrical signals, the electrode comprising:

- a band having an outside surface;

- a dome-like protuberance unitarily mounted on said outside surface, said dome-like protuberance having a radius of curvature in the range of 0.050" to 0.090"; and

- a gold-plated layer configured on said band and said dome-like protuberance.

13. An electrode in accordance with claim 12, wherein said electrode further comprises a means for facilitating circumferential attachment of said band to a probe.

14. An esophageal probe useful for invasively monitoring cardiac functions in the esophagus of a patient, the probe comprising:

- a chassis having a proximal end and a distal end; and

- at least one electrode configured on said chassis between said proximal end and said distal end, wherein said electrode comprises an annular ring and more than one dome unitarily arranged on said annular ring and configured for facilitating contact with a tissue wall of the esophagus of a patient.

15. An esophageal probe in accordance with claim 14, wherein said probe further comprises a deployment device attached to said chassis, wherein said deployment device is configured to stabilize the probe in the esophagus and limit movement of the probe within the esophagus.

16. An electrode for receiving electrical signals for cardiac measurement, said electrode comprising:

- a base portion having an exterior surface, said base portion being adapted to connect to a probe device; and

- a protruding member unitarily arranged on said exterior surface of said base portion, wherein said protruding member is configured substantially around an outer circumference of said base portion; and

- wherein each of said exterior surface of said base portion and said protruding member comprises a gold-plated layer adapted to reduce the difference in voltage potential between said electrode and another electrode.

17. An electrode of claim 16, wherein said base portion comprises an annular ring.

19

18. An electrode of claim 16, wherein said protruding member further comprises a radius of curvature in the range of 0.050" to 0.090".

19. An electrode of claim 18, wherein said radius of curvature is in the range of 0.065" to 0.070".

20. An esophageal probe useful for invasively monitoring cardiac functions in the esophagus of a patient, the probe comprising:

a chassis having a proximal end and a distal end; and at least one electrode, wherein said at least one electrode comprises,

an annular base having an exterior surface, and a protruding member having a radius of curvature in the range of 0.050" to 0.090";

wherein said exterior surface and said protruding member comprise a gold-plated layer adapted to reduce the difference in voltage potential between said at least one electrode and any other electrode configured on said chassis.

20

21. An esophageal probe according to claim 20, wherein said protruding member is configured substantially around an outer circumference of said annular base for facilitating contact with a tissue wall of the esophagus of a patient.

22. An esophageal probe according to claim 20, wherein said protruding member is integrally formed with said annular base, such that when used in connection with a probe configured for insertion into an anatomical canal of a human or animal, anatomical fluids are prevented from penetrating between a juncture defined by said protruding member and said annular base.

23. An esophageal probe according to claim 20, wherein said electrode further comprises a first connector and a second connector located on opposing sides of side annular base, said first and said second connectors configured to enable attachment of said electrode to said chassis.

* * * * *

专利名称(译)	用于通过食道评估心脏功能的电极		
公开(公告)号	US6438400	公开(公告)日	2002-08-20
申请号	US09/513737	申请日	2000-02-22
[标]申请(专利权)人(译)	希斯卡公司		
申请(专利权)人(译)	HESKA CORPORATION		
当前申请(专利权)人(译)	HESKA CORPORATION		
[标]发明人	BEARD LANE HOWARD JAMES P MELNIKOFF DONALD J YOUNG ROBERT L		
发明人	BEARD, LANE HOWARD, JAMES P. MELNIKOFF, DONALD J. YOUNG, ROBERT L.		
IPC分类号	A61B5/0408 A61B5/042 A61B5/00 A61B7/00 A61B7/02		
CPC分类号	A61B5/0421 A61B5/1459 A61B5/6852 A61B5/6853 A61B5/6855 A61B5/6859 A61B5/6885 A61B7/023 A61B2562/0209 A61B2562/043 A61M2205/3368		
审查员(译)	COHEN , LEE		
优先权	60/045006 1997-04-25 US 60/067810 1997-12-05 US		
外部链接	Espacenet USPTO		

摘要(译)

用于产生或接收电信号的电极通常包括基座和在基座的外表面上的多于一个的圆顶状突起。电极可以与各种探针应用结合使用。例如，电极可以与食道探针一起使用，用于侵入性地监测心脏功能，包括患者的ECG或心输出量。为了进一步最小化可能由接触点处存在的电解质引起的电压电位差，可以在电极的外表面上提供镀金层。示范性探针通常包括底盘，该底盘具有从底盘的近端延伸的电缆，并且电缆终止于配置用于连接到心脏监测器的电插头。该探针还包括电极组件，该电极组件包括圆顶状突起并且被配置为产生或接收指示患者的心脏功能的电信号。探针还可包括附接到底盘的展开装置，用于稳定食道内的探针。探针还可以配置为包括其他传感装置，例如温度测量装置和声学监测器。

