



US 20130158364A1

(19) **United States**

(12) **Patent Application Publication**  
**Hayn et al.**

(10) **Pub. No.: US 2013/0158364 A1**

(43) **Pub. Date: Jun. 20, 2013**

(54) **DEVICE EMBODIED TO MEASURE VITAL PARAMETERS OF A PATIENT**

*A61B 5/1455* (2006.01)

*A61B 5/08* (2006.01)

*A61B 7/02* (2006.01)

*A61B 5/00* (2006.01)

*A61B 5/021* (2006.01)

(71) Applicant: **Robert Bosch GmbH**, Stuttgart (DE)

(72) Inventors: **Henning Hayn**, Stuttgart (DE); **Ulrich Ladstaetter**, Weinstadt (DE)

(52) **U.S. Cl.**

CPC ..... *A61B 5/0205* (2013.01); *A61B 5/00* (2013.01); *A61B 5/1116* (2013.01); *A61B 5/1121* (2013.01); *A61B 5/1124* (2013.01); *A61B 5/01* (2013.01); *A61B 5/1072* (2013.01); *A61B 5/0402* (2013.01); *A61B 5/021* (2013.01); *A61B 5/14532* (2013.01); *A61B 5/087* (2013.01); *A61B 5/1455* (2013.01); *A61B 5/082* (2013.01); *A61B 7/02* (2013.01); *A61B 5/0059* (2013.01); *A61B 5/4872* (2013.01); *A61B 5/4875* (2013.01); *A61B 5/0004* (2013.01); *A61B 5/103* (2013.01)

(73) Assignee: **Robert Bosch GmbH**, Stuttgart (DE)

(21) Appl. No.: **13/711,697**

(22) Filed: **Dec. 12, 2012**

(30) **Foreign Application Priority Data**

Dec. 16, 2011 (DE) ..... 10 2011 088 817.9

USPC ..... **600/301**

**Publication Classification**

(51) **Int. Cl.**

*A61B 5/0205* (2006.01)  
*A61B 5/11* (2006.01)  
*A61B 5/01* (2006.01)  
*A61B 5/107* (2006.01)  
*A61B 5/0402* (2006.01)  
*A61B 5/103* (2006.01)  
*A61B 5/145* (2006.01)  
*A61B 5/087* (2006.01)

(57)

**ABSTRACT**

A measuring device includes a plurality of measuring modules and a control module. The plurality of measuring modules is configured to measure vital parameters of a patient, with at least two measuring modules of the plurality of measuring modules being configured to measure different vital parameters. The control module is configured to evaluate the measured vital parameters and/or to carry out calculations based on the measured vital parameters.

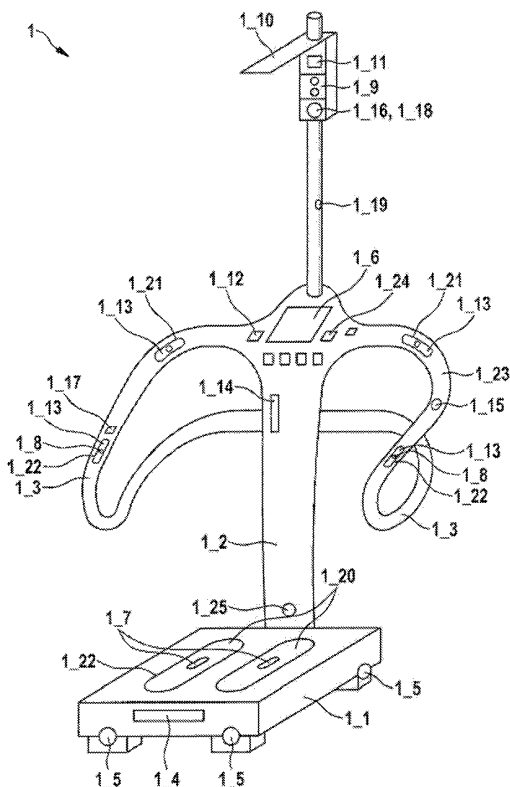

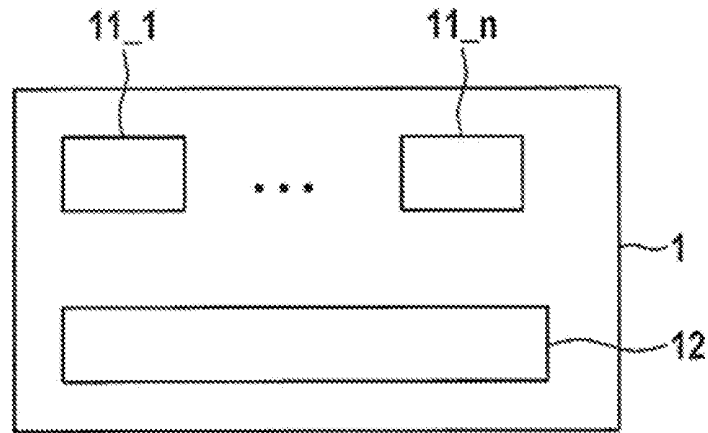

Fig. 1

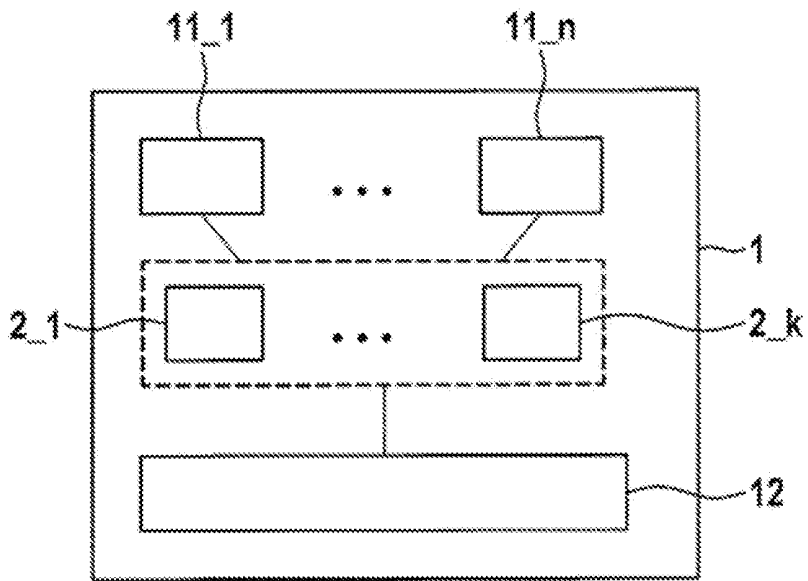

Fig. 2

one of the measuring modules 11<sub>1</sub> to 11<sub>n</sub>, for example via a (suitable) quick-release fastener. By way of example, at least one of the quick-release fasteners can be a plug-in connection, a sliding connection, a screw connection or a clamping connection, wherein use can also be made of other quick-release fasteners that are suitable for this. A person skilled in the art generally knows of quick-release fasteners.

**[0028]** The device 1 can have at least one interface for connecting the measuring modules 11<sub>1</sub> to 11<sub>n</sub> to the control module 12. This further design of the device 1 is shown in FIG. 2. The interfaces 2<sub>1</sub> to 2<sub>k</sub> can have different designs. Thus, for example, each measuring module 11<sub>1</sub> to 11<sub>n</sub> can be connected to the control module over a specific interface 2<sub>1</sub> to 2<sub>k</sub>. Furthermore, there can be interfaces 2<sub>1</sub> to 2<sub>k</sub> which connect a plurality of measuring modules 11<sub>1</sub> to 11<sub>n</sub> (i.e. more than one measuring module 11<sub>1</sub> to 11<sub>n</sub>) to the control module 12. Moreover, there can also be a single interface 2<sub>1</sub> to 2<sub>k</sub> for connecting the measuring modules 11<sub>1</sub> to 11<sub>n</sub> to the measuring module 11<sub>1</sub> to 11<sub>n</sub>. That is to say k is a natural number which is greater than or equal to one. The interfaces 2<sub>1</sub> to 2<sub>k</sub> serve to transfer data between the control module 12 and the measuring modules 11<sub>1</sub> to 11<sub>n</sub>. Here, the interfaces 2<sub>1</sub> to 2<sub>k</sub> are designed to transfer the vital parameters measured by the measuring modules 11<sub>1</sub> to 11<sub>n</sub> to the control module 12. According to one exemplary embodiment, the individual measuring modules 11<sub>1</sub> to 11<sub>n</sub> can communicate via a data bus (e.g. CAN bus). Here the control module 12 has interfaces 2<sub>1</sub> to 2<sub>k</sub> to the bus system for the measuring modules 11<sub>1</sub> to 11<sub>n</sub>. According to a further exemplary embodiment, the communication from the measuring modules 11<sub>1</sub> to 11<sub>n</sub> to the control module 12 can take place by means of e.g. interfaces 2<sub>1</sub> to 2<sub>k</sub>, of which at least one of the interfaces 2<sub>1</sub> to 2<sub>k</sub> can be one of the following interfaces: Bluetooth, ZigBee, infrared interface, cabled connection (e.g. USB, RS 232, other type of cabled connection). Here, it is also possible to use other interfaces 2<sub>1</sub> to 2<sub>k</sub> that are suitable and known to a person skilled in the art.

**[0029]** Furthermore, a mixed form of the two exemplary embodiments is also possible, i.e. some of the measuring modules 11<sub>1</sub> to 11<sub>n</sub> can be connected to the control module 12 via a data bus and some of the measuring modules 11<sub>1</sub> to 11<sub>n</sub> can be connected thereto via a different type of interface 2<sub>1</sub> to 2<sub>k</sub> (as listed above in an exemplary fashion). Moreover, the interfaces can be arranged in and/or on the control module 12, as shown in FIG. 3.

**[0030]** The device 1 can be designed to communicate with at least one further (medical) device 41. This is illustrated in FIG. 4 in an exemplary fashion, wherein the device 1 moreover can also be designed as illustrated in FIGS. 1 to 3 in an exemplary fashion. In order to communicate with further devices 41, the device 1 can have further interfaces 4<sub>1</sub> to 4<sub>m</sub>, which enable the communication between the device 1 and the at least one further device 41. These interfaces 4<sub>1</sub> to 4<sub>m</sub> can have a similar design to the above-described interfaces 2<sub>1</sub> to 2<sub>k</sub>. Thus, an interface 4<sub>1</sub> to 4<sub>m</sub> can connect one, some or all of the further (medical) devices 41 to the device 1 for the transmission of data. At least one of the interfaces 4<sub>1</sub> to 4<sub>m</sub> can be one of the following interfaces: Bluetooth, infrared interface, cabled connection (e.g. USB, RS 232, other type of cabled connection). It is also possible to use other interfaces which are suitable for this. A person skilled in the art is generally aware of such interfaces. The further interfaces 4<sub>1</sub> to 4<sub>m</sub> can be arranged in and/or on the

control module 12, as shown in FIG. 5 in an exemplary fashion, wherein the device 1 in FIG. 5 can also be designed as illustrated in an exemplary fashion in FIGS. 1 to 3.

**[0031]** The control module 12 can be designed to calculate characteristics and/or further information in respect of the patient, in respect of whom the measurements are carried out by the device 1, on the basis of the measured vital parameters.

**[0032]** Characteristics and the fundamentals of calculating the latter are well known. In general, a characteristic is an index serving to quantify the measured vital parameters. The characteristic is based on a prescription/definition for the quantitatively reproducible measurement of the measured vital parameters. The characteristics can be defined in the device 1 or in the control module 12. After measuring the vital parameters, the characteristics are calculated by the device 1 or the control module 12. The calculated characteristics can display further information in respect of the state of the patient and/or can be used to calculate further information in respect of the state of the patient. In the following text, a few characteristics and their use are listed in an exemplary (but not exhaustive) fashion. An exemplary characteristic can specify the BMI, which is calculated according to the following formula:  $BMI = m/l^2$ , where m specifies the body mass and l specifies the body height. At least one of the two values m and l can be measured as vital parameter by the measuring modules 1<sub>1</sub> to 1<sub>n</sub> of the measuring system, i.e. the device 1. The characteristic specifying the BMI can be calculated by the device 1 or the control module 12. A further exemplary characteristic can specify the Broca index, which can be calculated by means of the formula  $m_{norm} = (1-100) kg$ , with the Broca index defining the normal weight  $m_{norm}$  of a person via the height l and with it being possible for the height l, as a vital parameter, to have been measured by means of the measuring modules 1<sub>1</sub> to 1<sub>n</sub> of the device 1. According to the present disclosure, any number of further characteristics can be defined and/or calculated. Here, it is possible, for example, for the measured vital parameters to be put in relation to one another or in relation to the age and/or to other patient-specific factors, parameters, values and specifications. The characteristics can be compared to predetermined (limit) values, which can for example be stored (e.g. in tables) in the device 1 or in the control module 12, and can as a result of this display the state of the patient. Such further characteristics can display values which are generally used under the term fitness score. It is also possible to form characteristics from the relation of various gas components in the respiratory air. Furthermore, it is possible to define and/or calculate characteristics which reproduce a risk assessment of the patient. A characteristic formed from e.g. weight, body water percentage and blood pressure can provide an indication of an upcoming exacerbation in the case of patients with chronic obstructive pulmonary disease (COPD). A person skilled in the art is aware of the breadth of variation when defining and calculating characteristics. The present disclosure can therefore be used in respect of any suitable characteristic.

**[0033]** As already illustrated above in an exemplary fashion, it is possible, for example, to calculate the BMI as characteristic from the vital parameters such as weight and body height, or it is possible calculate corresponding blood concentrations as characteristics from the vital parameters such as the measured respiratory gas concentrations, which characteristics can be connected to further specifications of the state of the patient (e.g. there may be further risks in the case of a specific BMI). The further specifications for example

constitute such further information, with it also being possible to determine other information from the measured vital parameters. A person skilled in the art is well aware of how to calculate further information on the basis of the vital parameters.

**[0034]** As mentioned previously, the device **1** can be designed to communicate with at least one further device **41**. In the process, the device **1** can transmit the vital parameters, characteristics and/or other information calculated on the basis of the measured vital parameters to the further devices **41**. The further devices **41** can be designed to receive the vital parameters, characteristics and/or other information calculated on the basis of the measured vital parameters from the device **1** and moreover to store them, process them, evaluate them, use them for other calculations, display them and/or transfer them. The device **1** can furthermore be designed to receive data or information from the at least one further device **41**, wherein this data or information can be data or information relating to e.g. at least one patient, for example relating to the patient in respect of whom the device **1** carries out the measurements. This data or information can for example have predetermined limits in respect of the calculated characteristics and/or in respect of the measured vital parameters, which limits can also be e.g. patient-specific (e.g. related to the patient to be measured). As a result of the comparison of the characteristics and/or the vital parameters with the limits predetermined on a patient-individual basis (by means of the device **1** or by means of the control module **12**), the device **1** can immediately, and without first having to transfer data to the at least one further device **41**, give the patient feedback in respect of the measured values, e.g. by a suitable indication (e.g. visually, acoustically, speech).

**[0035]** As a result of measuring a plurality of vital parameters, it is also possible to carry out plausibility tests in respect of individual vital parameters and/or characteristics by means of the device **1** or by means of the control module **12**. By way of example, the concurrent increase of body weight and body water percentage can indicate water retention (e.g. in the case of COPD (chronic obstructive pulmonary disease) patients). The results of such plausibility tests, which calculate relationships between the vital parameters, the characteristics and/or the further information calculated from the vital parameters can be indicated by the device **1**, e.g. by means of a suitable indication (e.g. visually, acoustically, speech), and/or transferred to at least one further device **41**.

**[0036]** The device **1** or the control module **12** can be designed to identify the patient, on whom the measurements should be undertaken, on the basis of patient-specific characteristics which were calculated on the basis of the measured vital parameters in respect of the patient. By way of example, this is expedient when the device **1** is used by a plurality of patients/users. The identification of the user e.g. exclusively via the weight as one vital parameter is not always unique. As a result of the combination with other vital parameters, i.e. on the basis of calculated characteristics, the device **1** or the control module **12** can uniquely identify the patient (even without an additional biometric sensor). To this end, the device **1** can have an entry module, by means of which the respective characteristic identifying the patient can be entered. After identifying the patient, the device **1** or the control module **12** can be designed to link the measured vital parameters, the characteristics calculated from the measured vital parameters and/or further information to the identified patient, for whom the measurements were carried out.

**[0037]** FIG. **6** shows the device **1** for measuring vital parameters according to a further exemplary embodiment of the present disclosure, in which a more specific design of the device **1** with the modules **11\_1** to **11\_n** has been shown in an exemplary fashion. It is understood that, according to the present disclosure, other more specific designs of the device **1** with the modules **11\_1** to **11\_n** are also possible. The device **1** can also only have some of the modules from FIG. **6** and/or can have other modules as well.

**[0038]** According to the present exemplary embodiment, the device **1**, which is embodied as an integrated, modular measuring system for vital parameters, has a scales-like base module **1\_1**, which stands on the ground, and the following modules: a central column **1\_2**; handles **1\_3**; for the base module **1\_1**, respectively a force sensor or a force measuring module **1\_4** which can be designed to measure the weight; for the base module **1\_1**, a plurality of further force sensors or force measuring modules **1\_5**, which can be designed to measure the balance, body center of gravity, coordination; a human-machine interface **1\_6** (e.g. display, keys, loudspeakers); for lower extremities, temperature sensors or temperature measuring modules **1\_7** which can be installed in the base module **1\_1**; for upper extremities, temperature sensors or temperature measuring modules **1\_8** which can be installed in the handles **1\_3** of the device **1**; a temperature sensor or temperature measuring module **1\_9** for the forehead (e.g. contactless via infrared); a measuring apparatus for the body height **1\_10** (via a mechanical system or by optical means); an additional display or indication module **1\_11** (e.g. for installation into the measuring apparatus for the body height); an EKG module **1\_12** (e.g. with a connector for 12-channel electrodes); dry electrodes **1\_13** (e.g. for installation into the handles **1\_3** of the device **1**); a blood pressure measuring module **1\_14**; a blood sugar measuring module **1\_15**; a spirometry measuring module **1\_16**; a module for photometric blood analysis **1\_17** (e.g. a finger slot for pulse oximetry); a respiratory gas analysis module **1\_18**; a microphone **1\_19** (e.g. electronic stethoscope); for the lower extremities, an impedance sensor or an impedance measuring module **1\_20** which can be installed in the base module **1\_1**; for upper extremities, an impedance sensor or an impedance measuring module **1\_21** which can be installed in the handles **1\_3** of the device **1**; for optical feedback, a light source **1\_22** which can be installed in the handles **1\_3** or in the base module **1\_1** of the device **1**; for haptic feedback, actuators **1\_23** which can be installed in the handles **1\_3** or in the base module **1\_1** of the device **1**; a biometric sensor or a biometric measuring module **1\_24** for identifying and authenticating the user (e.g. a fingerprint sensor); a camera **1\_25** for the optical examination of skin or body parts on the basis of image-processing modules or units (e.g. for examining diabetic necrosis on the feet).

**[0039]** The base module **1\_1** in FIG. **6** corresponds to the control module **12** explained above. The base module **1\_1** in FIG. **6** or the control module **12** respectively is a central control unit of the device **1**. The base module **1\_1** or the control module **12** can respectively have: a control element (e.g. a microcontroller) for instrument and/or module control and for evaluating the measured vital parameters; an energy supply; interfaces **2\_1** to **2\_k** for the individual modules **1\_2** to **1\_25** and interfaces **4\_1** to **4\_m** for communication with further (medical) devices (e.g. a telemedical platform/device), wherein the communication can be implemented by means of Ethernet, modem, GSM, UMTS etc.

**[0040]** The modules 1\_1 to 1\_25 can, where necessary, be combined amongst themselves as desired, to the extent that this is possible from a construction point of view. If the body scales function is not required, the base module 1\_1 in FIG. 6 can also be placed or arranged elsewhere in the device 1 (e.g. not standing on the ground, as illustrated in FIG. 7 in an exemplary fashion). The base module 1\_1 can also be arranged in the device 1 and designed such that it is suitable for physically disabled patients (e.g. for wheelchair users). In the process, it is ensured that the implementation and/or the installation of the base module 1\_1 is such that the relevant measurement sites of the respective patient can be accessed.

**[0041]** According to the present exemplary embodiment, the temperature sensors or temperature measuring modules 1\_7 for the lower extremities (i.e. feet) can be arranged in the treads in the base module 1\_1. Using the surface temperatures of the extremities measured by the temperatures sensors and/or temperature measuring modules 1\_7, it is possible to draw conclusions, e.g. in the case of diabetes diseases, in respect of the perfusion of the lower extremities in order then to determine a lack of perfusion such as diabetic necrosis at an early stage. The conclusions can (at least in part) be drawn in the base module 1\_1 and/or in a further device (after the transmission of the measured temperatures and/or other relevant information, characteristics), such as e.g. a telemedical platform.

**[0042]** As shown in FIG. 6, the device 1 can, according to the present exemplary embodiment, have a biometric sensor or a biometric measuring module 1\_24 for the reliable identification of the patient (e.g. via fingerprints).

**[0043]** According to the present exemplary embodiment, the human-machine interface (HMI) 1\_6 can be arranged centrally at the upper end of the central column Said interface has a (e.g. LCD, TFT, OLED, etc.) display and optionally operating keys to execute inputs. The HMI 1\_6 can also be arranged differently in the device 1; here it should, in general, be positioned such that it can easily be reached and/or is visible by the patient and/or by the other operator of the device. The HMI 1\_6 can also have a touch display or touchscreen.

**[0044]** The patient/user can obtain (precise) instructions/indications by means of the HMI 1\_6 in respect of which measurement(s) is/are currently being carried out. Furthermore, the patient/user can obtain (precise) instructions/indications by means of the HMI 1\_6 in relation to the behavior in view of and/or during the measurement(s). The instructions/indications can, for example, be provided by acoustic, haptic and/or optical means (e.g. by text, videos and/or images, etc.).

**[0045]** The regions/areas of the sensors/measuring modules to be touched, such as e.g. the tread onto which the foot of the patient should be placed, the contact areas for the upper extremities, can for example be indicated by means of light sources 1\_22. By way of example, a light source 1\_22 can have LEDs, LEDs, incandescent lamps and/or glow lamps. Other embodiments of the light sources 1\_22 are also possible.

**[0046]** Placement and/or operating errors can be indicated graphically, haptically (e.g. by means of vibration etc.) and/or acoustically (e.g. by means of signal tone, speech output, etc.). By way of example, this can be brought about by means of the HMI 1-6. A correct or wanted placement and/or operation can also be indicated, e.g. by means of the HMI 1\_6 and/or the light sources 1\_22.

**[0047]** The central column 1\_2 can have an extendable design. By extending the central column 1\_2, it is possible to expand the device 1 by further sensors/measuring modules, e.g. by sensors/measuring modules for the body height 1\_10 and forehead temperature 1\_9, as shown in an exemplary fashion in FIG. 6. It should be noted here that the central column 1\_2 can be extended to complement the device 1 with other sensors/measuring modules as well. In order to expand the central column 1\_2 by further sensors/measuring modules, a carriage can be applied to the extension of the central column 1\_2. A bracket can be arranged on the central column 1\_2 and it can approach the head surface automatically by means of a drive or manually. A sensor can be used to stop the bracket just above the head or when it touches the head (e.g. via ultrasound, optical means etc.). The body height can be established from the position of the carriage on the central column (path sensors). A display can be integrated into the carriage and it is designed to display the measured body height (e.g. in cm, inches or in another unit). By way of example, the display can be an LCD, TFT, OLED or another type of displays or display devices.

**[0048]** Sensors/measuring modules can also be arranged in the carriage itself. Thus, for example, a holder device for an integrated temperature sensor and/or for an integrated temperature measuring module 1\_9 can be placed in the carriage. The temperature sensor or the temperature measuring module 1\_9 can detect/measure the surface temperature on the forehead of the patient by means of a thermometer (e.g. pyrometer).

**[0049]** FIG. 8 shows the device 1 for measuring vital parameters as per a further exemplary embodiment of the present disclosure. The design of the device 1 of FIG. 8 can substantially be similar to the device 1 of FIG. 6. Using the device 1 from FIG. 8, it is possible to measure the forehead temperature and the body height measurements from the central column 1\_2. The respective sensors/measuring modules 8 are arranged in the central column 1\_2. By way of example, the forehead temperature can be measured by means of a pyrometer 8. By way of example, the body height can be measured by means of a laser-distance sensor (or a laser-distance measuring module) and an associated calculation method or by means of an optical system (e.g. camera).

**[0050]** Furthermore, the base module 1\_1 with the central column 1\_2 can be complemented by a connection option for the blood pressure measurement 1\_14. The connector for measuring blood pressure 1\_14 can for example be a connector for receiving the measured value from peripheral equipment (e.g. a device which is built outside of the device 1, connected to the device 1 via the connector and designed to measure blood pressure) such as a Bluetooth connector or a connector for a pressure tube for the oscillatory measurement.

**[0051]** In the device 1, the base module 1\_1 can be expanded by the central column 1\_2, an EKG module 1\_12 and a blood pressure measuring module 1\_14 and by a module for carrying out a method for pulse transit time measurement. To this end, a slot 1\_17 for respectively one finger, for measuring pulse waves, can be embodied on the left-hand and right-hand sides of the handle frame.

**[0052]** The one, or both, slots 1\_17 can be designed to undertake or at least aid a photometric analysis of the blood. In the process, the following vital parameters, for example, can be captured/measured: oxygen saturation (SpO<sub>2</sub>); the carbon monoxide content in the blood (SpCO); level of meth-

emoglobin (SpMet); and/or further measurement or vital parameters, which can be captured by photometric means.

**[0053]** According to a further embodiment, the slot 1\_17 can be embodied as a further peripheral device, which can be clipped or attached to a finger and can therefore also be operated independently of the device 1. The slot 1\_17 designed as a peripheral device can be connected to the device 1 by means of e.g. Bluetooth, infrared, cabled connections (e.g. by means of USB, RS 232, etc.) or by means of plugging the photometric analysis equipment into a contact point of the device 1. By way of example, the contact point can be arranged in the handle frame of the device 1. In an exemplary fashion, FIG. 9 shows a finger-slot sensor or a finger-slot measuring module 9 as the slot 1\_17, which is embodied as a peripheral device. According to the exemplary embodiment of FIG. 9, the finger-slot measuring module 9 has the following components: a body 9\_1, a display or a screen 9\_2, a multifunction switch or a multifunction joint 9\_3, a slot 9\_4 for a finger, contact points 9\_5 and infrared diodes 9\_6, wherein the contact points 9\_5 and the infrared diodes 9\_6 can be arranged on the rear side 9\_7 of the finger-slot measuring module 9.

**[0054]** The base module 1\_1 with the central column 1\_2 and with the extension of the central column 1\_2 of the device 1 can be complemented by a height-adjustable respiratory gas analysis module 1\_18. The central column 1\_2 of the device can be designed such that the respiratory gas analysis module 1\_18 can be displaced manually or automatically on the central column 1\_2. FIG. 10 shows an exemplary respiratory gas analysis module 10 (provided with the reference sign 1\_18 in FIG. 6), as can be used to complement the device 1. According to the exemplary embodiment of FIG. 10, the respiratory gas analysis module 10 can have the following components: a housing 10\_1 with a receptacle hole 10\_3 for the mouthpiece 10\_4, a communication unit for data interchange with the base module 1\_1 and with the sensor unit. The respiration analysis carriage can be used to detect various respiratory gases, e.g. CO, CO<sub>2</sub>, H<sub>2</sub>, C<sub>2</sub>H<sub>6</sub>O and/or other relevant compounds, the detection of which in this context is known to a person skilled in the art. The respiratory gas analysis module 10 can have a display or a screen 10\_2 on which the measured values or vital parameters are indicated with specifications in respect of present respiratory gases (and the concentrations thereof) and/or on which there is an indication whether the blown-in amount of air is sufficient (e.g. by realizing a traffic-light system or in a similar fashion).

**[0055]** Furthermore, sub-regions of the handles 1\_3 or of the handle frame and/or parts of the platform of the device 1 can be made of solid metal, and so the whole surface of the parts formed from solid metal can be used as a dry electrode 1\_13. The electrodes can likewise be used for a body impedance measurement in order to determine water retention e.g. in the legs or in the lung and in order to determine the cardiac output.

**[0056]** In general, the device 1 can be adapted and optimized for various patient groups. The sensors or the measuring modules can be selected depending on the relevant disorders and/or the examinations to be carried out and can be used with the device 1. Furthermore, the device 1 can be designed for various patient groups, e.g. for patients unable to walk, patients who only have limited ability to walk and/or lying-down patients.

What is claimed is:

1. A measuring device, comprising:
    - a plurality of measuring modules configured to measure vital parameters of a patient, with at least two measuring modules of the plurality of measuring modules being configured to measure different vital parameters; and
    - a control module configured to evaluate the measured vital parameters and/or to carry out calculations on the basis of the measured vital parameters.
  2. The measuring device according to claim 1, wherein:
    - the measuring device has a modular configuration, the plurality of measuring modules are removable from the measuring device,
    - the plurality of measuring modules are replaceable, and/or at least one new measuring module is addable to the measuring device.
  3. The measuring device according to claim 1, further comprising:
    - a plurality of interfaces configured to connect the measuring modules to the control module.
  4. The measuring device according to claim 1, wherein the control module is further configured (i) to calculate characteristics based on the measured vital parameters, and/or (ii) to calculate further information in respect of the patient based on the measured vital parameters.
  5. The measuring device according to claim 4, wherein:
    - the control module is further configured to compare the calculated characteristics to predetermined limits, and
    - the measuring device is configured to display a result of the comparison.
  6. The measuring device according to claim 4, wherein the measuring device is further configured to identify the patient based on patient-specific characteristics which were calculated based on the measured vital parameters in respect of the patient.
  7. The measuring device according to claim 6, wherein the measuring device is further configured to link the measured vital parameters to the identified patient after the patient has been identified.
  8. The measuring device according to claim 1, wherein the plurality of measuring modules includes at least one of the following measuring modules:
    - a weight measuring module,
    - a balance measuring module,
    - a body center of gravity measuring module,
    - a coordination measuring module,
    - a temperature measuring module,
    - a body height measuring module,
    - an EKG measuring module,
    - a blood pressure measuring module,
    - a blood sugar measuring module,
    - a spirometry measuring module,
    - a measuring module for photometric blood analysis,
    - a measuring module for respiratory gas analysis,
    - a stethoscope,
    - an impedance measuring module, and
    - an optical examination module,
- the temperature measuring module is configurable to measure the temperature of the lower extremities, the upper extremities, or on the forehead,
- the impedance measuring module is configurable to measure the impedance of the lower extremities or upper extremities, and

the optical examination module is configured to examine skin and/or body parts using image-processing units.

9. The measuring device according to claim 1, wherein the vital parameters indicate at least one of the following items of information:

vital parameters measured by an EKG,  
temperature,  
weight,  
body fat percentage,  
body water percentage,  
height,  
balance,  
body center of gravity,  
sense of poise,  
coordination,  
blood pressure,  
concentration of constituents of the respiration, and  
blood sugar.

10. The measuring device according to claim 1, wherein:  
the measuring device is configured to transmit measured vital parameters, characteristics calculated based on the measured vital parameters, and/or further information in respect of the patient calculated based on the measured vital parameters to a further measuring device and/or to receive data from the further measuring device,  
the data comprises data directed at the patient and/or pre-determined limits in respect of the calculated characteristics, and  
the limits are specific to the patient.

\* \* \* \* \*

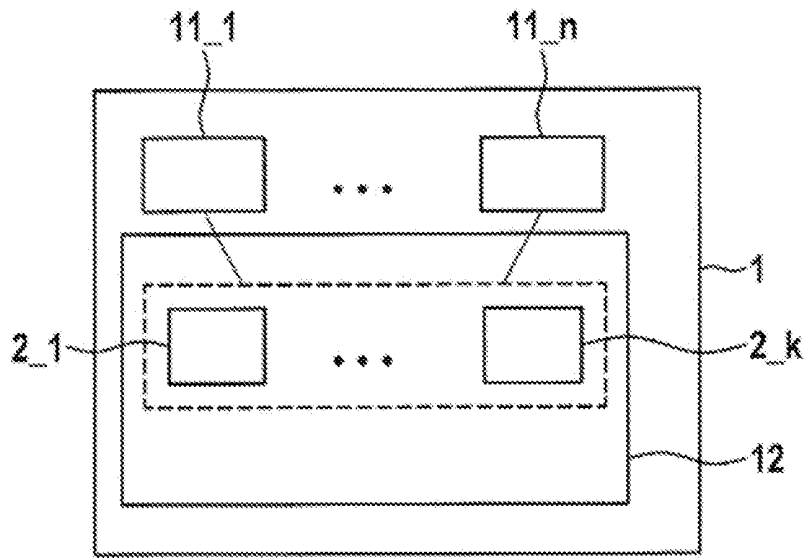

Fig. 3

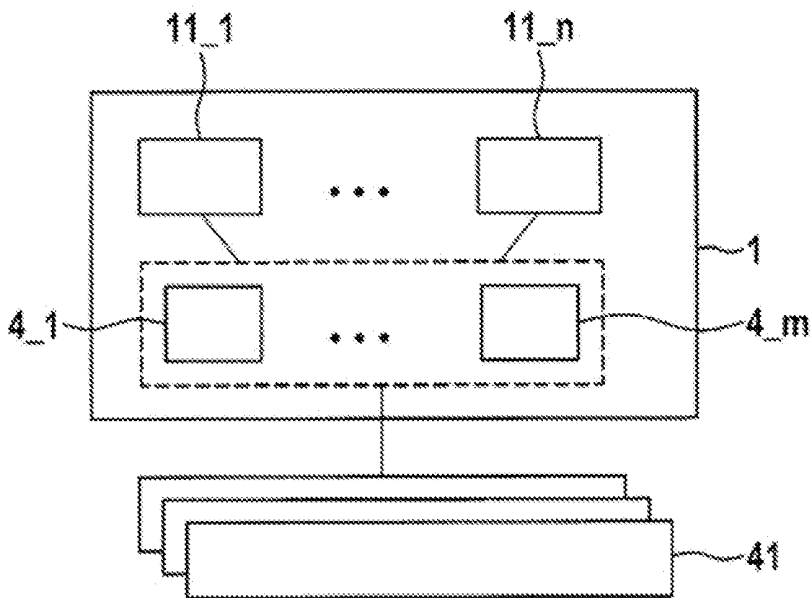

Fig. 4

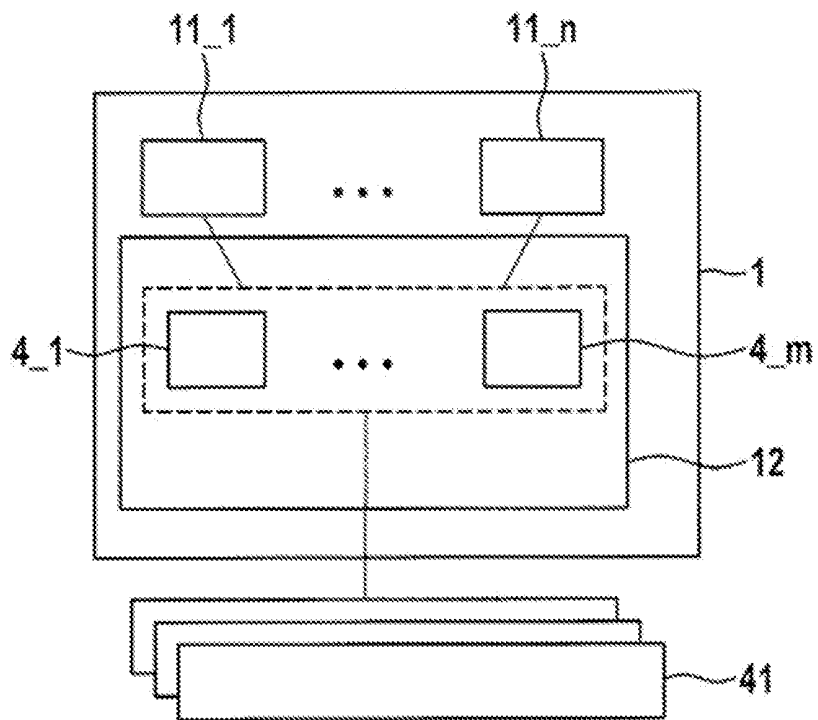

Fig. 5

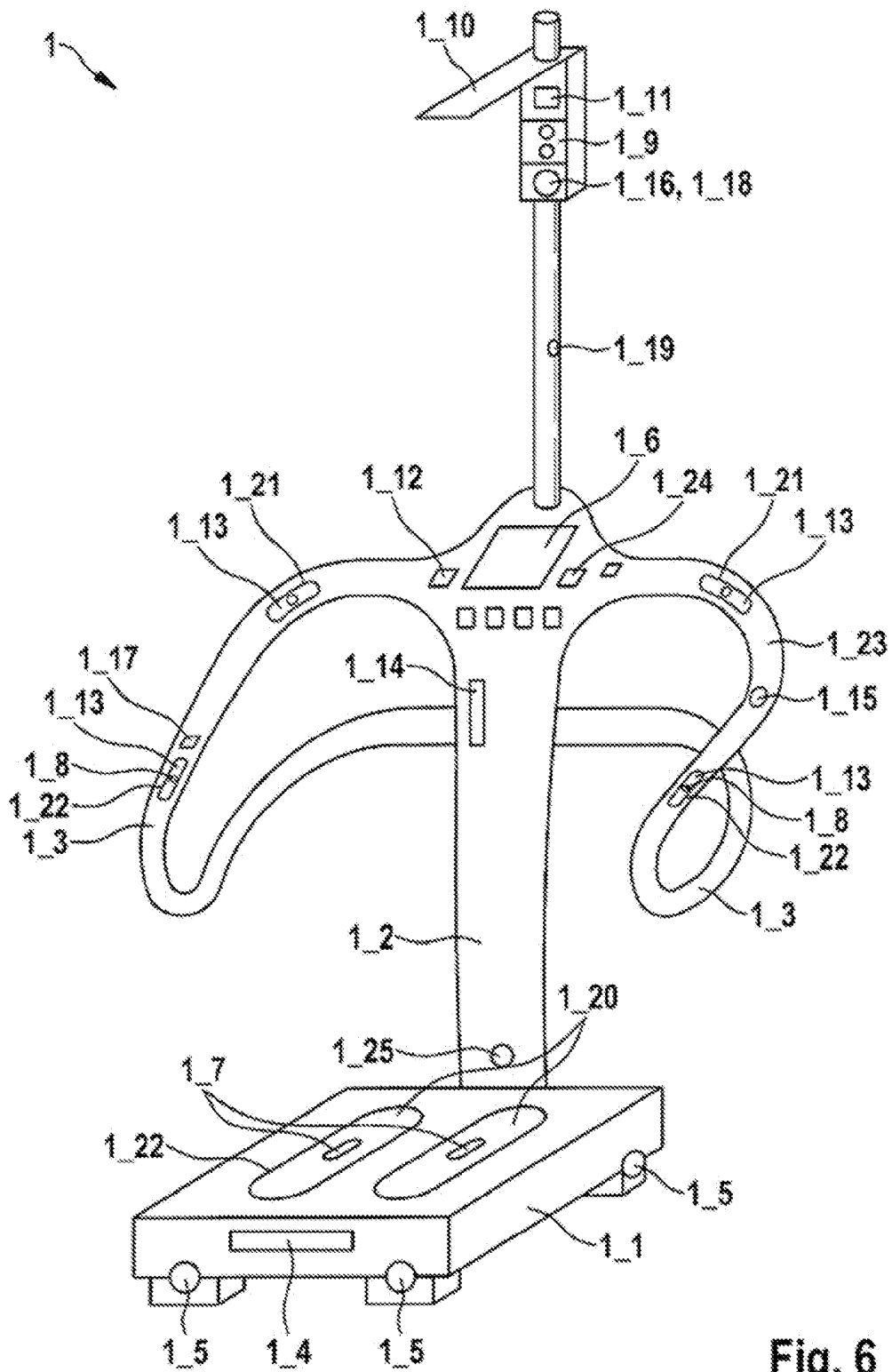

Fig. 6

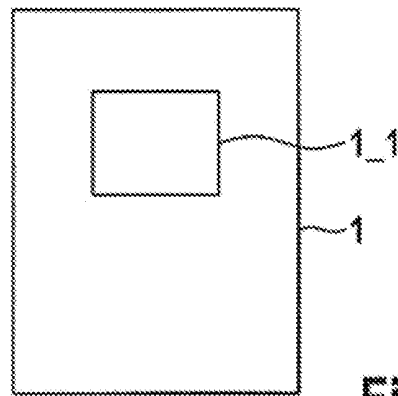

Fig. 7

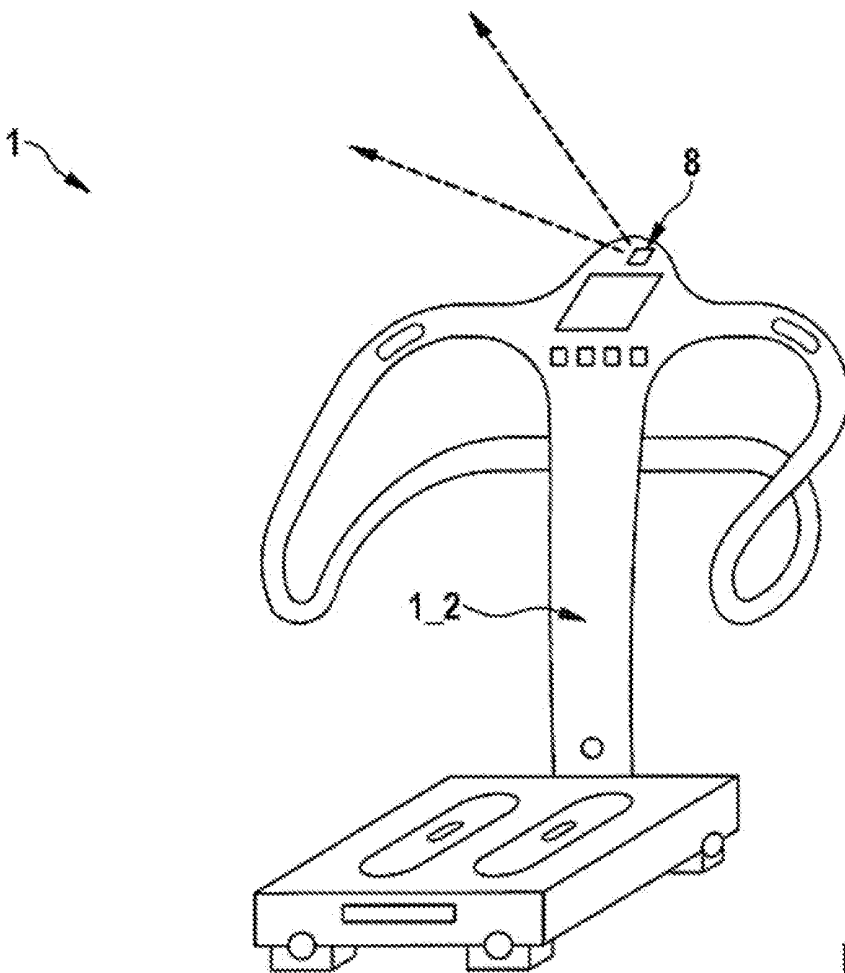

Fig. 8

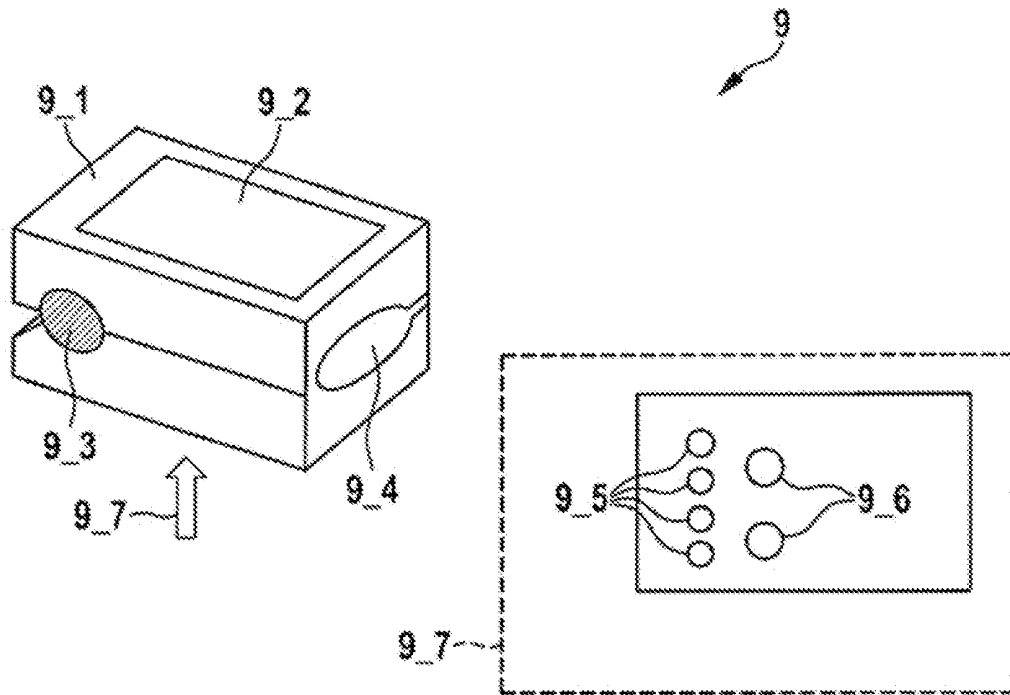

Fig. 9

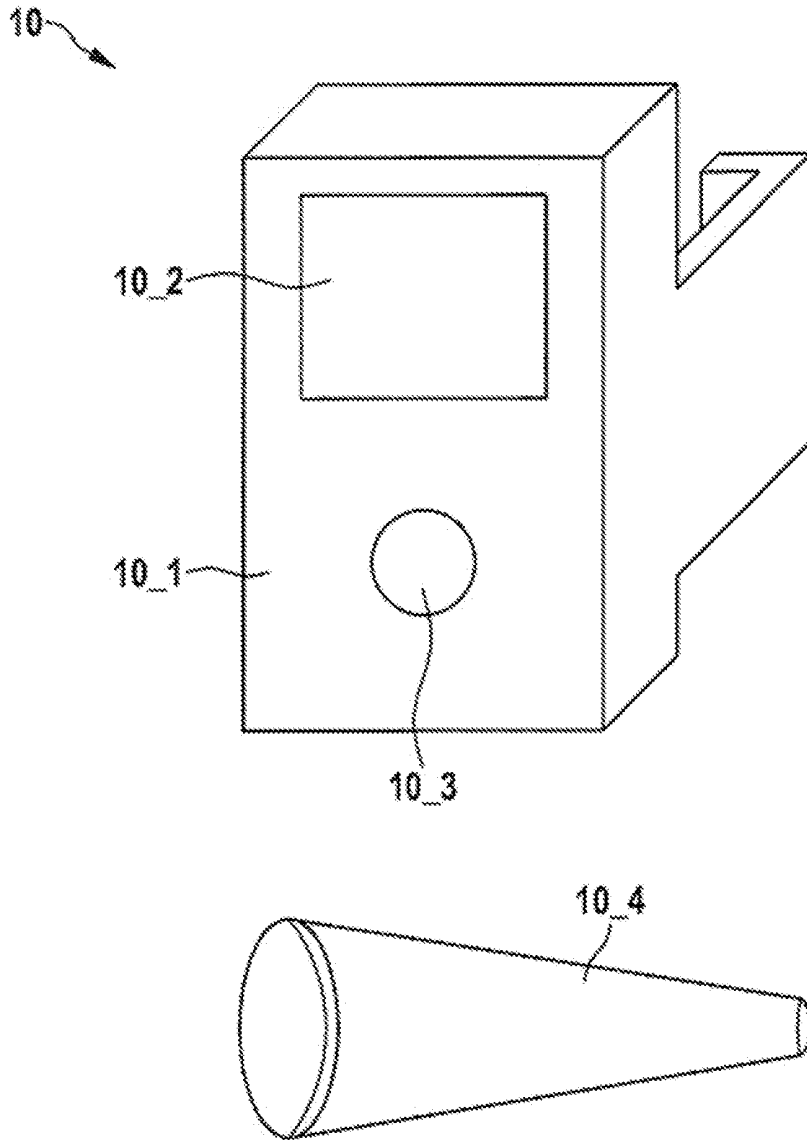

Fig. 10

## DEVICE EMBODIED TO MEASURE VITAL PARAMETERS OF A PATIENT

[0001] This application claims priority under 35 U.S.C. §119 to patent application no. DE 10 2011 088 817.9, filed on Dec. 16, 2011 in Germany, the disclosure of which is incorporated herein by reference in its entirety.

### BACKGROUND

[0002] The disclosure relates to a device which is embodied to measure vital parameters of a patient.

[0003] Known telemedical systems often consist of three components: the patient terminal; the interface for the medical specialist staff, for displaying data and for receiving inputs; and a server by means of which the patient data measured by the patient terminal is captured, processed and provided to the medical specialist staff via the interface. The patient terminals are often various items of peripheral equipment, which are connected to the telemedical system for capturing vital parameters. Vital parameters are well known and constitute indices which reflect the basic functions of the human body. In medicine, they are measured to monitor vital functions. Patient terminals can for example be blood pressure measuring equipment, blood sugar measuring equipment, spirometers, pulse oximeters, body scales, etc. Vital parameters are the data or values measured by the patient terminals. The vital parameters are read out from the patient terminals, transmitted to the server and subsequently made available to the specialist staff via the interface.

[0004] However, the problem of conventional telemedical systems is that the capture of vital parameters and the transmission thereof to the specialist staff is cumbersome for the patient and requires much time. There often is the need for painstaking individual configuration of the patient terminals, during which the patient terminals are personalized to the patient (e.g. by specifying the age, the sex, the body height, the weight, etc.). There can often be operating and/or input errors in a multiplicity of patient terminals. As a result of the multiplicity of necessary individual configurations and as a result of the multiplicity of patient terminals which can be operated and/or configured incorrectly, measurement errors which remain undetected often occur. Hence there still is a need for efficient, time-saving and flexible systems and devices, which enable error-free, efficient, flexible and time-optimized establishment and provision of patient data relating to the vital parameters.

### SUMMARY

[0005] The object of the present disclosure is to provide an improved device or an improved system, which is configured to establish, measure and/or calculate data relating to vital parameters, and to subsequently provide it.

[0006] The concept of the present disclosure lies in providing multifunctional measuring equipment or a multifunctional measuring device, which unifies a multiplicity of items of measuring equipment, measuring modules and/or sensors in one and moreover allows efficient, flexible, comprehensive and fast evaluation of the currently measured, evaluated data, with the data applying to a specific patient and relating to vital parameters.

[0007] The present disclosure provides a device, which enables error-free, fast and efficient measurements. Furthermore, the device also enables an error-free and effective evaluation of the measured data, which moreover relates to

correct and current information in respect of a patient. Moreover, the device can be designed and produced in a cost-effective manner when it enables and/or supports a modular design of the various measuring processes.

### BRIEF DESCRIPTION OF THE DRAWINGS

[0008] In the following figures, the disclosure will schematically be described in more detail on the basis of exemplary embodiments. Here, equivalent elements or elements having the same effect can be provided with the same reference sign for reasons of clarity.

[0009] FIG. 1 shows a device for measuring vital parameters according to one exemplary embodiment of the present disclosure;

[0010] FIG. 2 shows a device for measuring vital parameters according to one exemplary embodiment of the present disclosure;

[0011] FIG. 3 shows a device for measuring vital parameters according to one exemplary embodiment of the present disclosure;

[0012] FIG. 4 shows a device for measuring vital parameters according to one exemplary embodiment of the present disclosure;

[0013] FIG. 5 shows a device for measuring vital parameters according to one exemplary embodiment of the present disclosure;

[0014] FIG. 6 shows a device for measuring vital parameters according to one exemplary embodiment of the present disclosure;

[0015] FIG. 7 shows a device for measuring vital parameters according to one exemplary embodiment of the present disclosure;

[0016] FIG. 8 shows a device for measuring vital parameters according to one exemplary embodiment of the present disclosure;

[0017] FIG. 9 shows a finger-slot measuring module according to one exemplary embodiment of the present disclosure; and

[0018] FIG. 10 shows a respiratory gas analysis module according to one exemplary embodiment of the present disclosure.

### DETAILED DESCRIPTION

[0019] The figures relate to various aspects of the configuration of the device. It is therefore possible to combine together the exemplary embodiments of the device which are shown in the figures and described in the application. In the figures, this is clarified, inter alia, by the use of the same or similar reference signs.

[0020] FIG. 1 shows a device 1 for measuring vital parameters of a patient according to one exemplary embodiment of the present disclosure. Here the device 1 has a number of measuring modules 11\_1 to 11\_n, which are designed to measure vital parameters. According to the present exemplary embodiment, at least two measuring modules 11\_1 to 11\_n respectively measure different vital parameters. According to the present exemplary embodiment, the number of measuring modules 11\_1 to 11\_n is at least two measuring modules, i.e. n is a natural number greater than or equal to two. By way of example, vital parameters can be at least one of the following values measured at the patient: vital parameters measured by an electrocardiogram (EKG); temperature; weight; body fat percentage; body water percentage; (body)

height; balance; body center of gravity; sense of poise; coordination; blood pressure; concentration of constituents of the respiration; blood sugar. Here, according to the present disclosure, it is also possible to measure further vital parameters not listed above. Rather, the vital parameters listed above constitute an exemplary and not an exhaustive list. By way of example, measuring modules 11\_1 to 11\_n can have one of the following measuring modules or sensors: a weight measuring module; a balance measuring module; a body center of gravity measuring module; a coordination measuring module; a temperature measuring module, wherein the temperature measuring module can measure the temperature of the lower extremities, the upper extremities or on the forehead; a body height measuring module; an EKG measuring module; a blood pressure measuring module; a blood sugar measuring module; a spirometry measuring module; a measuring module for photometric blood analysis; a measuring module for respiratory gas analysis; a stethoscope; an impedance measuring module, wherein the impedance measuring module can measure the impedance of the lower extremities or upper extremities; an optical examination module (e.g. a camera), which can examine the skin and/or body parts using image-processing units. In this respect, it should be noted that the measuring modules 11\_1 to 11\_n listed above are only exemplary and have not been listed in an exhaustive fashion. Thus, the device 1 according to the present disclosure can also have further measuring modules 11\_1 to 11\_n, which are not listed above.

**[0021]** Furthermore, the device 1 according to the present exemplary embodiment has a control module 12, which is designed to evaluate the measured vital parameters and/or to carry out calculations on the basis of the measured vital parameters. Hence the evaluation of the measured information or vital parameters is respectively carried out in the device 1 itself without the need for respectively transmitting the information or vital parameters to a further device specifically designed to evaluate this data.

**[0022]** The measuring modules 11\_1 to 11\_n themselves can have various designs, with the design variety thereof being known to a person skilled in the art. By way of example, the weight measuring module can be a set of scales. By way of example, if use is made of medical scales, it is also possible to capture and measure the body height of a patient in addition to the weight of the patient. Overall, the device 1 or the control module 12 is able to capture or calculate further information or data in respect of the patient from the measured vital parameters. By way of example, the vital parameters weight and body height can be used to calculate the body mass index (BMI). If use is made of body-fat scales or body-water scales, it is also possible (e.g. using a bioelectric impedance analysis (BIA)) to establish or measure the percentage of the body water and of the body fat as further vital parameters, in addition to the weight. Furthermore, scales-like systems can be used as the weight measuring module. Such scales-like system can respectively have at least one integrated force sensor or at least one integrated force measuring module, in order to measure the body weight and the weight distribution as vital parameters. By way of example, it is possible to draw conclusions or determine or calculate information in respect of the body balance of the patient from the measured body weight and the measured weight distribution. The device 1 can also have a plurality of different measuring modules 11\_1 to 11\_n of the same type. By way of example, the device 1 can have a plurality of different sets of scales.

**[0023]** As presented above, a measuring module 11\_1 to 11\_n can measure more than one vital parameter. An EKG measuring module can, by means of further integrated sensors, for example additionally also measure vital parameters such as the oxygen saturation (SpO<sub>2</sub>), the carbon monoxide content (SpCO), the level of methemoglobin (SpMet), the expiratory carbon dioxide content (MetCO<sub>2</sub>) and/or the blood pressure (non-invasive/invasive (NIBP/IBP)).

**[0024]** The temperature measuring module or the thermometer can respectively likewise have various designs, for example in respect of how the measurement is taken. It is possible to carry out oral, axillary, rectal, vaginal, inguinal measurements using an analog or digital peak-value thermometer or measuring module. An ear thermometer makes it possible to carry out the measurement by measuring the infrared emissions from the eardrum. Furthermore, the temperature can also be measured by means of a contact measurement on the forehead or by means of a contactless surface thermometer (e.g. on the forehead).

**[0025]** By way of example, the design of the blood pressure measuring modules can depend on whether an invasive or non-invasive measuring method is used. In the case of invasive measurement of the blood pressure, there is arterial access to the bloodstream, with the access being secured by appropriately applying a catheter. The catheter is then connected to the blood pressure measuring module for measuring the blood pressure. In the case of a non-invasive measurement of the blood pressure, the measurement can be brought about by auscultation (by means of a blood pressure cuff that can be pumped manually and stethoscope), palpation (by means of a blood pressure cuff that can be pumped manually and by means of feeling the pulse), oscillation (electronically) or via the change in the pulse transit times.

**[0026]** Measuring modules for the respiratory gas analysis are designed to analyze the human respiratory air. In the process, it is possible to identify marker substances, which allow conclusions to be drawn in respect of the clinical state of a patient. By way of example, it is possible to determine concentrations of CO, CO<sub>2</sub>, H<sub>2</sub>, and C<sub>2</sub>H<sub>6</sub>O in the respiratory air. Each measured substance concentration can be considered to be a vital parameter. The measured concentrations can then be used to convert the respective respiratory gas concentrations into corresponding blood concentrations (as further information obtained from the vital parameters). According to the present exemplary embodiment, these calculations are carried out by the device 1 or by the control module 12. Measuring the concentrations themselves is well established and known to a person skilled in the art.

**[0027]** The device 1 can have such a modular design that the device permits the following: the removal of the measuring modules 11\_1 to 11\_n; the replacement of the measuring modules 11\_1 to 11\_n; and/or the addition of new measuring modules 11\_1 to 11\_n. As a result of this modular design, the device 1 can have a patient-individual design since not every patient requires all measuring modules 11\_1 to 11\_n. As a result, it is also possible to save costs when providing the measuring modules 11\_1 to 11\_n to a patient and/or when producing the device 1. If there is a change in the health situation (e.g. as a result of an occurring comorbidity or necessary temporary postoperative monitoring), additional measuring modules 11\_1 to 11\_n can be attached (also on a temporary basis) in a simple fashion. The measuring modules 11\_1 to 11\_n can likewise also be removed or replaced. The device 1 can be (modularly) connected or attached to at least

专利名称(译)	用于测量患者生命参数的装置		
公开(公告)号	<a href="#">US20130158364A1</a>	公开(公告)日	2013-06-20
申请号	US13/711697	申请日	2012-12-12
[标]申请(专利权)人(译)	罗伯特·博世有限公司		
申请(专利权)人(译)	罗伯特·博世有限公司,		
当前申请(专利权)人(译)	罗伯特·博世有限公司		
[标]发明人	HAYN HENNING LADSTAETTER ULRICH		
发明人	HAYN, HENNING LADSTAETTER, ULRICH		
IPC分类号	A61B5/0205 A61B5/11 A61B5/01 A61B5/107 A61B5/0402 A61B5/103 A61B5/145 A61B5/087 A61B5/1455 A61B5/08 A61B7/02 A61B5/00 A61B5/021		
CPC分类号	A61B5/1116 A61B7/04 A61B5/1124 A61B5/14532 A61B5/1455 A61B5/4872 A61B5/4875 A61B7/02 A61B5/00 A61B5/0004 A61B5/0059 A61B5/01 A61B5/0205 A61B5/021 A61B5/0402 A61B5/082 A61B5/087 A61B5/103 A61B5/1072 A61B5/0024 A61B5/0077 A61B5/02055 A61B5/0537 A61B5/0836 A61B5/14551 A61B5/4023 G01G19/44 A61B2560/0443 A61B5/1121		
优先权	102011088817 2011-12-16 DE		
外部链接	<a href="#">Espacenet</a> <a href="#">USPTO</a>		

摘要(译)

测量装置包括多个测量模块和控制模块。多个测量模块被配置为测量患者的生命参数，其中多个测量模块中的至少两个测量模块被配置为测量不同的生命参数。控制模块被配置为评估测量的生命参数和/或基于测量的生命参数执行计算。

