



US 20090182206A1

(19) **United States**

(12) **Patent Application Publication**
Najafi et al.

(10) **Pub. No.: US 2009/0182206 A1**

(43) **Pub. Date: Jul. 16, 2009**

(54) **WIRELESS DEVICE AND SYSTEM FOR MONITORING PHYSIOLOGIC PARAMETERS**

Publication Classification

(51) **Int. Cl.**
A61B 5/00 (2006.01)

(75) **Inventors:** **Nader Najafi**, Ann Arbor, MI (US);
Sonbol Massoud-Ansari, El Dorado Hills, CA (US); **Collin Anderson Rich**, Ypsilanti, MI (US)

(52) **U.S. Cl.** **600/301**

(57) **ABSTRACT**

Correspondence Address:
HARTMAN & HARTMAN, P.C.
552 EAST 700 NORTH
VALPARAISO, IN 46383 (US)

A system for monitoring blood pressure and other physiologic parameters is provided. The system is designed such that it can be delivered to the patient with ease and minimal invasion. The system contains at least one self contained implantable sensing device consisting of a sensor, an electrical circuit for signal conditioning and magnetic telemetry, a biocompatible outer surface and seal, an anchoring method, and an external readout device. The implant is small in size so that it may be delivered to the desired location and implanted using a catheter, although direct surgical implantation is also possible. The circuit, sensor, and antenna for telemetry are packaged together and sealed hermetically to the biologic environment. The larger readout unit remains outside the body but proximal to the implant for minimizing communication distance.

(73) **Assignee:** **INTEGRATED SENSING SYSTEMS, INC.**, Ypsilanti, MI (US)

(21) **Appl. No.:** **12/399,131**

(22) **Filed:** **Mar. 6, 2009**

Related U.S. Application Data

(62) Division of application No. 10/677,674, filed on Oct. 2, 2003.

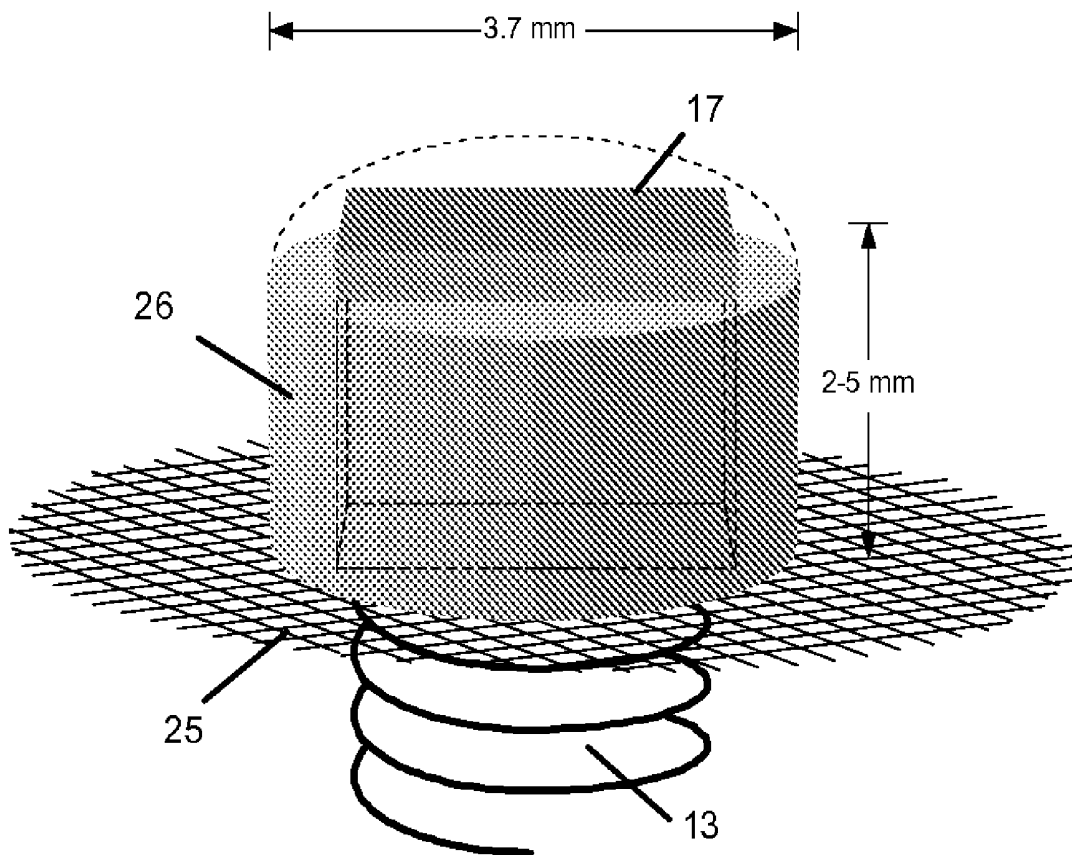

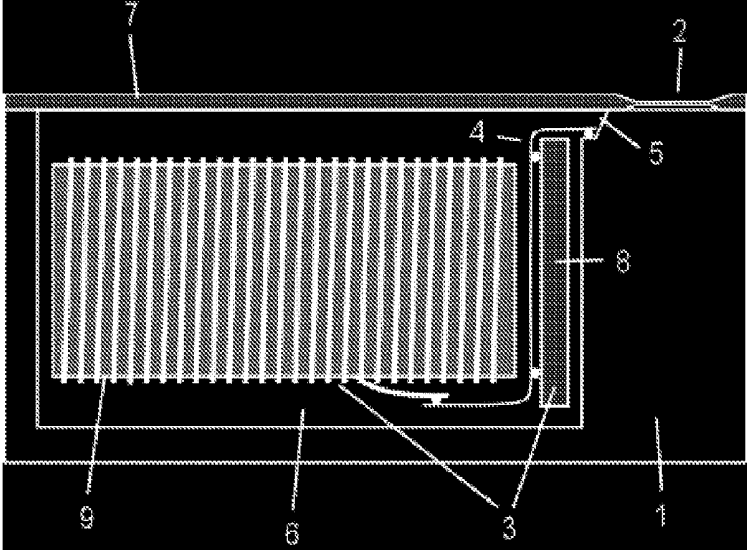

Figure 1

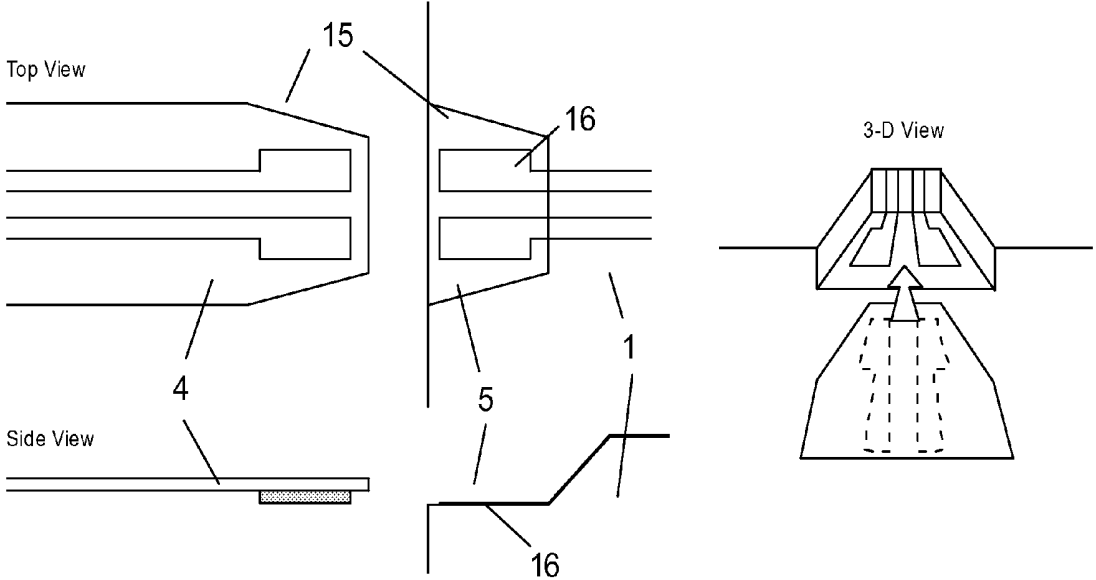

Figure 2

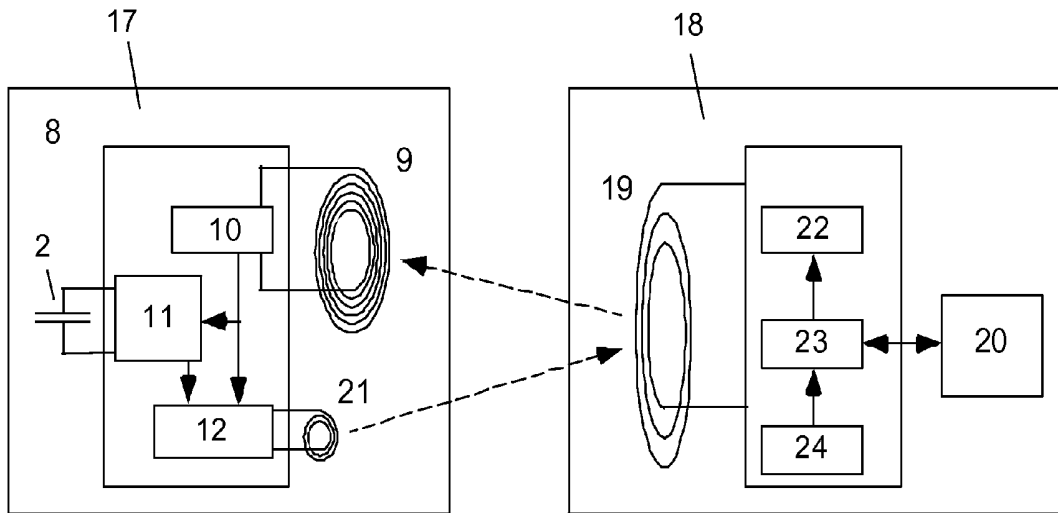

Figure 3

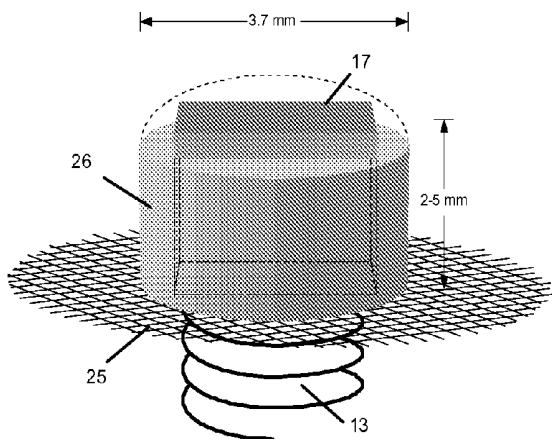

Figure 4

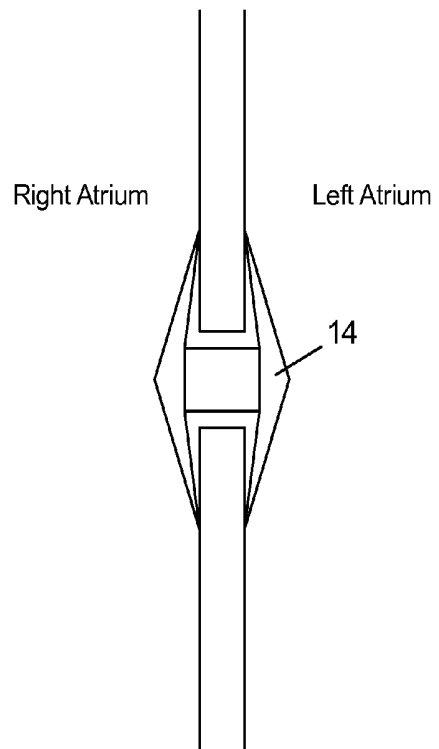

Figure 5

WIRELESS DEVICE AND SYSTEM FOR MONITORING PHYSIOLOGIC PARAMETERS

REFERENCE TO PREVIOUS APPLICATIONS

[0001] This application is a Division of co-pending U.S. patent application Ser. No. 10/677,674 filed Oct. 2, 2003.

FIELD OF THE INVENTION

[0002] This invention relates generally to medical devices monitoring blood pressure and other physiologic parameters.

BACKGROUND OF THE INVENTION

[0003] A number of different physiologic parameters are strong candidates for continuous monitoring, such as blood pressure or flow, cardiovascular pressure, intracranial pressure, intraocular pressure, glucose levels, etc. Wireless sensors in particular are highly desirable for biologic applications because the transcutaneous passage of wires (or other communication “tethers”) risks both infection to the patient and physical injury or device damage if the communication link experiences excessive pulling force.

[0004] A large number of proposed schemes for non-medical wireless communication rely on magnetic coupling between an electrical coil in an implanted device and a separate, external “readout” coil. One method of wireless communication well-known to those knowledgeable in the art is that of the LC tank resonator. A series-parallel connection of a capacitor and inductor has a specific resonant frequency ideally expressed as $1/\sqrt{LC}$, which can be measured from the impedance of the circuit. If one element of the inductor-capacitor pair varies with some physical parameter (e.g. pressure), while the other element remains at a known value, the physical parameter may be determined from the resonant frequency. For example, if the capacitor corresponds to a capacitive pressure sensor, the capacitance may be back-calculated from the resonant frequency. The sensed pressure may then be deduced from the capacitance by means of a calibrated pressure-capacitance transfer function.

[0005] The impedance of the LC tank may be measured directly or it may also be determined indirectly from the impedance of a separate readout coil that is magnetically coupled to the internal coil. The latter case is most useful for biologic applications in that the sensing device may be subcutaneously implanted, while the readout coil may be located external to the body, but in a location that allows magnetic coupling between the implant and readout coil. It is possible for the readout coil (or coils) to simultaneously excite the implant resonator and sense the impedance reflected back to the readout coil. Consequently, this architecture has the substantial advantage of requiring no internal power source, which greatly improves its prospects for long-term implantation (e.g. decades to a human lifetime).

[0006] Such devices have been proposed in various forms for many applications. Chubbuck (U.S. Pat. No. 4,026,276), Bullara (U.S. Pat. No. 4,127,110), and Dunphy (U.S. Pat. No. 3,958,558) disclose various devices initially intended for hydrocephalus applications (but also amenable to others) that use LC resonant circuits. The '276, '110, and '558 patents, although feasible, do not take advantage of recent advances in silicon (or similar) microfabrication technologies. Kensey (U.S. Pat. No. 6,015,386) discloses an implantable device for measuring blood pressure in a vessel of the wrist. This device

must be “assembled” around the vessel being monitored such that it fully encompasses the vessel, which may not be feasible in many cases. In another application, Frenkel (U.S. Pat. No. 5,005,577) describes an implantable lens for monitoring intraocular pressure. Such a device would be advantageous for monitoring elevated eye pressures (as is usually the case for glaucoma patients); however, the requirement that the eye’s crystalline lens be replaced will likely limit the general acceptance of this device.

[0007] In addition to the aforementioned applications that specify LC resonant circuits, other applications would also benefit greatly from such wireless sensing. Han, et al. (U.S. Pat. No. 6,268,161) describe a wireless implantable glucose (or other chemical) sensor that employs a pressure sensor as an intermediate transducer (in conjunction with a hydrogel) from the chemical into the electrical domain.

[0008] For example, the treatment of cardiovascular diseases such as Chronic Heart Failure (CHF) can be greatly improved through continuous and/or intermittent monitoring of various pressures and/or flows in the heart and associated vasculature. Porat (U.S. Pat. No. 6,277,078), Eigler (U.S. Pat. No. 6,328,699), and Carney (U.S. Pat. No. 5,368,040) each teach different modes of monitoring heart performance using wireless implantable sensors. In every case, however, what is described is a general scheme of monitoring the heart. The existence of a method to construct a sensor with sufficient size, long-term fidelity, stability, telemetry range, and biocompatibility is noticeably absent in each case, being instead simply assumed. Eigler, et al., come closest to describing a specific device structure although they disregard the baseline and sensitivity drift issues that must be addressed in a long-term implant. Applications for wireless sensors located in a stent (e.g., U.S. Pat. No. 6,053,873 by Govari) have also been taught, although little acknowledgement is made of the difficulty in fabricating a pressure sensor with telemetry means sufficiently small to incorporate into a stent.

[0009] Closed-loop drug delivery systems, such as that of Feingold (U.S. Pat. No. 4,871,351) have likewise been taught. As with others, Feingold overlooks the difficulty in fabricating sensors that meet the performance requirements needed for long-term implantation.

[0010] In nearly all of the aforementioned cases, the disclosed devices require a complex electromechanical assembly with many dissimilar materials, which will result in significant temperature- and aging-induced drift over time. Such assemblies may also be too large for many desirable applications, including intraocular pressure monitoring and/or pediatric applications. Finally, complex assembly processes will make such devices prohibitively expensive to manufacture for widespread use.

[0011] As an alternative to conventionally fabricated devices, microfabricated sensors have also been proposed. One such device is taught by Darrow (U.S. Pat. No. 6,201,980). Others are reported in the literature (see, e.g. Park, et al., *Jpn. J. Appl. Phys.*, 37 (1998), pp. 7124-7128; Puers, et al., *J. Micromech. Microeng.* 10 (2000), pp. 124-129; Harpster et al., *Proc. 14th IEEE Int'l. Conf. Microelectromech. Sys.* (2001), pp. 553-557).

[0012] Past efforts to develop wireless sensors have typically been limited to implant-readout separation distances of 1-2 cm, rendering them impractical for implantation much below the cutaneous layer. This would eliminate from consideration applications such as heart ventricle pressure monitoring or intracranial pressure monitoring, which require

separation distances in the range of 5-10 cm. In the present state-of-the-art, several factors have contributed to this limitation, including: 1) signal attenuation due to intervening tissue, 2) suboptimal design for magnetic coupling efficiency; and 3) high internal energy losses in the implanted device.

SUMMARY OF THE INVENTION

[0013] It is an object of this invention to provide a system for chronic monitoring of blood pressure and other physiological parameters.

[0014] It is also an object of this invention to provide a system including an implantable device for monitoring blood pressure and other physiologic parameters that is delivered to the patient with ease and minimal invasion.

[0015] It is also an object of this invention to provide a method for delivering an implantable device for monitoring blood pressure and other physiologic parameters that is delivered to the patient with ease and minimal invasion.

[0016] The above objects are achieved by providing at least a self contained implantable sensing device consisting of a sensor, an electrical circuit for signal conditioning and magnetic telemetry, a biocompatible outer surface and seal, an anchoring method, and an external readout device. The implant is small in size so that it may be delivered to the desired location and implanted using a catheter, although direct surgical implantation is also possible. The circuit, sensor, and antenna for telemetry are packaged together in a small volume and sealed hermetically to the biologic environment. The larger readout unit remains outside the body but proximal to the implant for minimizing communication distance.

BRIEF DESCRIPTION OF THE DRAWINGS

[0017] FIG. 1 is a side view of a miniature sensor module according to a preferred embodiment of the present invention.

[0018] FIG. 2 is a top, side, and perspective view of a flexible substrate to rigid substrate self aligning connection illustrating a preferred arrangement of electrical leads within a substrate cavity.

[0019] FIG. 3 is a block diagram of a magnetic telemetry based physiologic monitoring system according to a preferred embodiment of the present invention.

[0020] FIG. 4 is a perspective view of a sensor implant incorporating a screw anchoring mechanism.

[0021] FIG. 5 is a side view of a sensor implanted in the atrial septum according to a preferred embodiment of the present invention.

DETAILED DESCRIPTION OF PREFERRED AND ALTERNATE EMBODIMENTS OF THE INVENTION

[0022] The following description of preferred embodiments and methods provides examples of the present invention. The embodiments discussed herein are merely exemplary in nature, and are not intended to limit the scope of the invention in any manner. Rather, the description of these preferred embodiments and methods serves to enable a person of ordinary skill in the relevant art to make, use and perform the present invention.

[0023] The preferred communication scheme for the present invention, shown in FIG. 3, is based on magnetic telemetry. Without an external reader present, the implant device lays passive and without any internal means to power

itself. When a pressure reading is desired, the reader device is brought into a suitable range to the implant. The reader then creates an RF (Radio Frequency) magnetic field large enough to induce sufficient voltage across the implant coil. When such a sufficient voltage exists across the implant coil, the implant circuit may rectify the alternating waveform to create a direct voltage, which analog and/or digital circuitry may use as a power supply. At this point the implant can be considered alert and, in the preferred embodiment, also ready for commands from the reader.

[0024] Once the direct voltage in the implant has been established for the circuit operation, a number of techniques may be used to convert the sensor output into a form suitable for transmission back to the reader device. In the preferred embodiment, a capacitive pressure sensor and sigma delta conversion or capacitance to frequency conversion of the sensor output may be easily used. Capacitive sensors are preferred due to the small power requirements for electronics when reading capacitance values. Many pressure sensors are based on piezoresistive effects and, while suitable for some applications, do suffer in this application due to the higher power levels needed for readout. Sigma delta converters are preferred due to the tolerance of noisy supply voltages and manufacturing variations.

[0025] As those skilled in magnetic telemetry are aware, a number of modulation schemes are available for transmitting data via magnetic coupling. The preferred schemes include but are not limited to amplitude modulation, frequency modulation, frequency shift keying, phase shift keying, and also spread spectrum techniques. The preferred modulation scheme may be determined by the specifications of an individual application, and is not intended to be limited under this invention.

[0026] In addition to the many available modulation techniques are the many technologies developed that allow the implant to communicate back to the reader the signal containing pressure information. It is understood that the reader device may transmit either a continuous level of RF power to supply the implant's needed energy, or it may pulse the power allowing temporary storage in a battery or capacitor device. Similarly, the implant 17 of FIG. 3 may signal back to the reader 18 at any interval in time, delayed or instantaneous, during reader RF transmission or alternately in the absence of reader transmission. The implant 17 may include a single coil antenna 9 for both reception and transmission, or it may include two antennas, one each for transmission 21 and reception 9.

[0027] The preferred embodiment of the invention is based on a small inner package, preferably of glass and silicon, that can be fit with a number of shell options for various implantation methods. The cross-section in FIG. 1 illustrates a glass and silicon package for the miniature sensor module according to a preferred embodiment of the invention. As illustrated in FIG. 1, the submodule includes a substrate 1, a miniature sensor 2, and electronics 3 (both coil 9 and integrated circuit 8 included in electronics). A secondary and optional substrate 4 may be used for attaching the various electronic components to each other and to sensor connections. An alternative preferred method is to use a cylindrical shaped package, made from silicon, glass, ceramic, metal, plastic, or any combination thereof which houses the coil and the electronic components. The miniature sensor can either be fabricated separately and attached to the cylindrical package or may be directly fabricated onto the substrate. Note that the shell may

be a separately fabricated piece into which the sensor is placed; or it may be directly fabricated on the sensor submodule (or some portion thereof); or it may be integral to the inner package, being only defined by a change in material.

[0028] The purpose of the shell is to simplify fabrication by allowing different processes, process flows, materials, and/or structures to be used for the subassembly (e.g. MEMS technologies) and the shell (e.g. machining and/or molding of plastics, glass, metals, rubbers, polymers, etc.) In some applications, the material of the sensor submodule may be compatible with the environment, in which case a shell is not required and the submodule becomes the completed sensor.

[0029] The miniature sensor can be any suitable miniature sensor adapted to detect and/or monitor various physiological parameters. For example, the sensor can comprise a pressure sensor, a temperature sensor, a flow sensor, a velocity sensor, or a sensor adapted to measure specific chemistries such as gas content (e.g., O₂ and CO₂) and glucose levels. Various specific examples of these types of miniature sensors are known to those skilled in the art, and any one or more of these suitable sensors can be utilized in the sensor module of the present invention. While the specific type of sensor(s) chosen will depend on the application of the implantable system, the sensor(s) should be of a sufficiently small size in order to facilitate placement within a catheter for delivery and implantation.

[0030] In the preferred embodiment of the sensor shown in FIG. 1, the bottom substrate 1 defines a cavity 6 in which the electronics 3 may be placed. With cubic geometry, the rigid substrate cavity walls enclose the electronics on five of the six possible sides. Also in a preferred embodiment, at least part of the sensor is disposed on the top side of the bottom substrate 1. Connections to the sensor 2 may be made in a substrate recess 5 (recess is optional for increased clearance, and connection may alternately be co-planar with or above the plane of the substrate) adjoining the larger cavity 6, or through alternate lead transfer techniques in the substrate cavity.

[0031] The top substrate 7 is attached to the bottom substrate 1 to form a hermetic seal around the sensor and electronics. In a preferred embodiment, the physically interacting parts of the sensor are formed in the top substrate and complete the sensor structure after subsequent processing steps after bonding. The two substrates may be made of materials such as glass and silicon that are preferably anodically bonded together and provide excellent bond mechanical properties. Alternate methods of attachment include: fusion, frit, solder, laser welds, other welding, compression, thermal, thermal compression, eutectic, glue.

[0032] In a preferred arrangement, the electronic circuitry is connected together via a rigid or flexible substrate, which may be either the bottom substrate 1 or a separate substrate 4. The connection between the integrated circuit die 8 and substrate is preferably made with flip-chip process to avoid the more fragile wire bonds. The circuit die may include ASIC (Application Specific Integrated Circuits), capacitors, or diodes. The leads from the inductor 9 may fold over the substrate or preformed for soldering to the substrate with a preferably biocompatible solder such as gold-tin or silver-tin. The flexible substrate may also extend to the connections for the sensor, where the connection may be made with a number of methods such as silver epoxy, laser welding, solder, or other.

[0033] Aligning the flexible substrate 4 to the bottom substrate recess 5 is shown in FIG. 2. A preferred structure to

accommodate manufacturing tolerances matches the tapered recess in the bottom substrate to the flex circuit, ensuring that the electrical contacts are properly aligned. As the wedge 15 is inserted into the recess, the electrical connections 16 are forced to align themselves to avoid faulty connections. Furthermore, any variance in the width of the tapers will be accommodated by a small variation in the final, lateral depth of insertion of the flex circuit.

[0034] FIG. 3 illustrates a block diagram for the electronics 3 according to the present invention. The electronic circuit may consist of a receiving inductor coil 9, rectification circuitry 10, signal conditioning circuitry 11, and signal transmission circuitry 12.

[0035] A large number of possible geometries and structures are available for receiver coil and known to those skilled in the art. The coil conductor may be wound around a ferrite core to enhance magnetic properties, deposited on a flat rigid or flexible substrate, and formed into a long/skinny or short/wide cylindrical solenoid. The conductor is preferably made at least in part with a metal of high conductivity such as copper, silver, gold. The coil may alternately be fabricated on substrates 1, 4, or 8 (or any combination thereof) of FIG. 1. Methods of fabrication include sputtering, electroplating, lift-off, screen printing, and/or other suitable methods known to those skilled in the art.

[0036] The rectification circuitry 10 outputs a constant voltage level for the other electronics from an alternating voltage input. Efficient realizations of such circuitry are standard electronic techniques and may include full bridge diode rectifiers in the preferred embodiment. This rectification circuitry may include a capacitor for transient energy storage to reduce the noise ripple on the output supply voltage. This circuitry may be implemented on the same integrated circuit die with other electronics.

[0037] The signal conditioning circuit 11 processes an output signal from the sensor 2 and prepares it for transmission to an external receiving and/or analyzing device. For example, many pressure sensors output a capacitance signal that may be digitized for radio frequency (RF) transmission. Accordingly, the signal conditioning circuit places the output signal of the sensor into an appropriate form. Many different signal conditioning circuits are known to those skilled in the art. Capacitance to frequency conversion, sigma delta or other analog to digital conversion techniques are all possible conditioning circuits that may be used in a preferred embodiment.

[0038] The signal transmission circuitry transmits the encoded signal from the signal conditioning circuitry for reception by an external reader. Magnetic telemetry is again used for this communication, as the transmission circuitry generates an alternating electromagnetic field that propagates to the reader. Either the same coil 9 is used for signal reception and for transmission, or alternately a second coil 21 is dedicated for transmission only.

[0039] To limit the risk of thrombogenesis, the preferred embodiment has limited protrusion of volume into the blood stream, as both shape and size are factors in thrombogenesis. Another shell may be overmolded or preformed to house the glass/silicon module, and the outer shell contains the necessary apparatus for anchoring the implant. In a preferred embodiment, the outer shell may be formed with existing plastic injection technologies suitable for medical implanta-

tion. A coating, preferably of silicone, parylene and/or polymers provides a non-thrombogenic exterior for the biologic environment.

[0040] The implant may be located in various places depending on the blood pressure measurement of interest. For chronic heart failure the end-diastolic pressure may be of most importance, and therefore the left chambers of the heart or immediately attaching vessels may be preferred locations. Because the number of implants is not practically limited by the technology, multiple locations for blood pressure and/or other physiologic parameter measurements are easily established, including all chambers of the heart, major arteries and appendages. In the preferred embodiment, embedding the module in an area that does not significantly impede blood flow can minimize the thrombogenic effect of flow turbulence caused by this volume.

[0041] The implant may be modified with anchoring methods found on devices already used for implantation. Devices such as septal occluders, pacemaker leads, left atrial appendage occluders, etc. may be used as carriers for the current invention.

[0042] Pacemaker leads have a well-established history for implantation methods, and similar techniques are possible for the current invention. A screw **13** or barb may be used to attach the implant to a heart or vessel wall. In the first package option shown in FIG. 4, a screw may be molded into the device shell **26**, and screwed into the ventricle wall so that the screw buries below the wall surface. In addition, the package may have mesh **25** attached to the device to promote tissue growth and anchoring.

[0043] A second package option can be attached with a metal tine or barb placed with a catheter. These devices work well in tribeculated areas of the heart, and therefore are used often for implanting pacing leads in the right ventricle. Clips or expanding probes may also be used, both of which would penetrate the heart or vessel wall slightly.

[0044] Devices have been made and approved by the FDA to occlude atrial septum defects (a septal occluder) and other vascular holes. An umbrella structure **14** may be folded inside a catheter for delivery and then expanded for implantation. In a preferred embodiment, the present invention may be anchored to the septum with similar techniques, as shown in FIG. 5. An important aspect of this preferred embodiment is that the majority of the implantable sensing device is located in the right side of the heart, with minimum protrusion in the left side of the heart. This embodiment will greatly reduce the thrombogenicity.

[0045] The readout device **18** includes an inductor **19** for communicating with and powering the implant **17** via magnetic telemetry. Also included is signal reception **24**, signal processing **23**, and transmission circuitry **22** for data analysis and subsequent communication. FIG. 3 illustrates the system diagram and the blocks of the reader. There are many techniques for construction of the reader coil and processing electronics known to those skilled in the art. The reader may interface to a display, computer, or other data logging device **20**.

[0046] Note that in addition to sensing physiologic parameters, the described system could be augmented with various actuation functions. In such case, the implant device would be augmented with any of various actuators, including but not limited to: thermal generators; voltage or current sources, probes, or electrodes; drug delivery pumps, valves, or meters;

microtools for localized surgical procedures; radiation-emitting sources; defibrillators; muscle stimulators; pacing stimulators.

[0047] The foregoing disclosure includes the best mode devised by the inventors for practicing the invention. It is apparent, however, that several variations in the apparatuses and methods of the present invention may be conceivable by one skilled in the art. Inasmuch as the foregoing disclosure is intended to enable one skilled in the pertinent art to practice the instant invention, it should not be construed to be limited thereby, but should be construed to include such aforementioned variations.

We claim:

1. A miniature implant for measuring physiologic parameters for medical applications, comprising:

Implantable self-contained sensor module for measuring physiologic parameters wherein the module:

- senses physiologic parameters with a sensor;
- receives operating power from a magnetic field with an inductor coil;
- conditions a sensor signal;
- transmits a conditioned sensor signal to an external signal detection system via magnetic telemetry;
- outer shell to house sensor module fit with anchoring mechanism for implantation.

2. The system of claim 1 wherein said implantable sensing device is implanted using a minimally invasive outpatient technique

3. The miniature implant of claim 1 wherein the implant is delivered and implanted with a catheter.

4. The miniature implant of claim 1 wherein said anchoring mechanism passes through a septum wall and opens on either side of a septal wall, clamping the implant to the wall.

5. The system of claim 4 wherein said anchoring mechanism utilizes an anchor that passes through the atrial septum.

6. The system of claim 5 wherein said anchoring method is similar to anchoring of septum occluder devices, wherein two umbrella-shaped anchors one on each side which anchor the sensing device.

7. The system of claim 5 wherein the larger portion of said implantable sensing device is located in the right side of the heart and the smaller portion of said implantable sensing device is located in the left side.

8. The miniature implant of claim 1 wherein said anchoring mechanism is a helical screw.

9. The miniature implant of claim 1 wherein said anchoring mechanism is a tine that expands and catches on a tribeculated area of the heart.

10. The system of claim 1 wherein said anchoring mechanism is made from one or more or any combination thereof the following materials: nitinol, teflon, stainless steel, polymer, titanium, biocompatible metals.

11. The system of claim 1 wherein at least a portion of said sensor module is coated with one or more layers of thin coatings.

12. The system of claim 11 wherein said coating materials include but are not limited to one or more or any combination thereof: silicone, hydrogels, parylene, polymer, nitrides, oxides, nitric-oxide generating materials, carbides, silicides, titanium.

13. A wireless sensing system for medical applications, comprising:

Implantable self-contained sensor module for measuring physiologic parameters wherein the module:

- senses physiologic parameters with a sensor;
 receives operating power from a magnetic field with an inductor coil;
 conditions a sensor signal;
 transmits a conditioned sensor signal to an external signal detection system via magnetic telemetry;
 External readout unit wherein the unit:
 transmits magnetic field to power the sensor module;
 receives a signal from the implant module.
14. The wireless sensing system of claim 13 wherein said external readout unit communicates information to the implant.
15. The wireless sensing system of claim 13 wherein said external readout unit interfaces to a display for the user.
16. The wireless sensing system of claim 13 wherein said external readout unit interfaces to a computer for data storage.
17. The wireless sensing system of claim 13 wherein said computer interfaces with a computer network.
18. The wireless sensing system of claim 13 wherein said external readout unit processes the data for indicating urgency of medical attention.
19. The wireless sensing system of claim 13 wherein said external readout unit is capable of performing one or more of the following:
 remote monitoring of patients, including but not limited to home monitoring;
 monitoring of congestive heart failure patients with telephone-based (or similar method) data and information delivery;
 monitoring of patients with wireless telephone-based (or similar method) data and information delivery;
 monitoring of congestive heart failure patients with web-based (or similar method) data and information delivery;
 closed-loop drug delivery to treat diseases;
 closed-loop pacemaker parameter tuning to treat related diseases;
 warning systems for critical worsening of diseases and related conditions;
 portable or ambulatory monitoring or diagnostic systems;
 battery-operation capability;
 data storage;
 reporting global positioning coordinates for emergency applications;
 communication with other medical devices including but not limited to pacemakers, defibrillator, implantable cardioverter defibrillator, implantable drug delivery systems, non-implantable drug delivery systems, and wireless medical management systems.
20. The system of claim 13 wherein said readout unit includes a barometric pressure sensor.
21. The system of claim 20 wherein said barometric pressure sensor is used to compensate for variations in atmospheric pressure.
22. The system of claim 13 wherein said implantable sensing system is implanted using a minimally invasive outpatient technique.
23. The miniature implant of claim 13 wherein said implant is delivered and implanted with a catheter.
24. The miniature implant of claim 13 wherein said anchoring mechanism passes through a septum wall and opens on either side of a septal wall, clamping the implant to the wall.
25. The system of claim 13 wherein said anchoring mechanism utilizes an anchor that passes through the atrial septum.
26. The system of claim 25 wherein said anchoring method is similar to anchoring of septum occluder devices, wherein two umbrella-shaped anchors one on each side which anchor the sensing device.
27. The system of claim 25 wherein the larger portion of said implantable sensing device is located in the right side of the heart and the smaller portion of said implantable sensing device is located in the left side.
28. The miniature implant of claim 13 wherein said anchoring mechanism is a helical screw.
29. The miniature implant of claim 13 wherein said anchoring mechanism is a tine that expands and catches on a trabeculated area of the heart.
30. The system of claim 13 wherein said anchoring mechanism is made from one or more or any combination thereof the following materials: nitinol, teflon, stainless steel, polymer, titanium, biocompatible metals.
31. The system of claim 13 wherein at least a portion of said sensor module is coated with one or more layers of thin coatings.
32. The system of claim 31 wherein said coating materials include but are not limited to one or more or any combination thereof: silicone, hydrogels, parylene, polymer, nitrides, oxides, nitric-oxide generating materials, carbides, silicides, titanium.
33. The implant of claim 1 wherein said module is used for applications including but not limited to one or more of the following: cardiovascular diseases, congestive heart failure, congenital heart diseases, diseases related to intracranial pressure, abdominal aortic aneurysm, intraocular pressure for eye related diseases including but not limited to glaucoma, urinary diseases, gastrointestinal diseases.
34. The wireless sensing system of claim 13 wherein said module is used for applications including but not limited to one or more of the following: cardiovascular diseases, congestive heart failure, congenital heart diseases, diseases related to intracranial pressure, abdominal aortic aneurysm, intraocular pressure for eye related diseases including but not limited to glaucoma, urinary diseases, gastrointestinal diseases.
35. The sensor module of claim 1 wherein said sensor measures one or more of the following parameters pressure, temperature, flow, blood composition, blood gas content, chemical composition, acceleration, vibration.
36. The sensor module of claim 13 wherein said sensor measures one or more of the following parameters: pressure, temperature, flow, blood composition, blood gas content, chemical composition, acceleration, vibration.
37. The sensor module of claim 1 wherein one or more sensing devices are measuring one or more physiological parameters relating to one or more internal organs
38. The sensor module of claim 37 wherein said physiological parameters include pressure.
39. The sensor module of claim 37 wherein said internal organs include but are not limited to one or more of the following organs: heart, brain, kidney, lung, abdomen.
40. The sensor module of claim 38 wherein one or more sensing devices are measuring one or more of the following pressures: left ventricular end diastolic pressure, left atrium, left atrium appendage, mean left atrium pressure, left side of the heart, right side of the heart, right atrium, mean right atrium pressure, right ventricular end diastolic pressure, differential pressure between left and right atrium, intracranial pressure, intraocular pressure.

41. The sensor module of claim **13** wherein one or more sensing devices are measuring one or more physiological parameters relating to one or more internal organs

42. The sensor module of claim **41** wherein said physiological parameters include pressure.

43. The sensor module of claim **41** wherein said internal organs include but are not limited to one or more of the following organs: heart, brain, kidney, lung, abdomen.

44. The sensor module of claim **42** wherein one or more sensing devices are measuring one or more of the following pressures: left ventricular end diastolic pressure, left atrium, left atrium appendage, mean left atrium pressure, left side of the heart, right side of the heart, right atrium, mean right atrium pressure, right ventricular end diastolic pressure, differential pressure between left and right atrium, intracranial pressure, intraocular pressure.

* * * * *

专利名称(译)	用于监测生理参数的无线设备和系统		
公开(公告)号	US20090182206A1	公开(公告)日	2009-07-16
申请号	US12/399131	申请日	2009-03-06
申请(专利权)人(译)	集成传感系统, INC.		
当前申请(专利权)人(译)	集成传感系统, INC.		
[标]发明人	NAJAFI NADER MASSOUD ANSARI SONBOL RICH COLLIN ANDERSON		
发明人	NAJAFI, NADER MASSOUD-ANSARI, SONBOL RICH, COLLIN ANDERSON		
IPC分类号	A61B5/00		
CPC分类号	A61B5/0031 A61B2560/0219 A61B5/6882 A61B5/0215 A61N1/37223		
优先权	60/416407 2002-10-07 US 60/416406 2002-10-07 US 60/416409 2002-10-07 US 60/416408 2002-10-07 US 60/415538 2002-10-03 US 60/415537 2002-10-03 US		
其他公开文献	US9498130		
外部链接	Espacenet USPTO		

摘要(译)

提供了一种用于监测血压和其他生理参数的系统。该系统被设计成使得它可以容易地和最小的侵入地递送给患者。该系统包含至少一个自包含的可植入传感装置,其包括传感器,用于信号调节和磁遥测的电路,生物相容的外表面和密封,锚定方法和外部读出装置。植入物尺寸小,因此可以将其递送到期望的位置并使用导管植入,尽管也可以进行直接手术植入。用于遥测的电路,传感器和天线被封装在一起并密封在生物环境中。较大的读出单元保持在身体外部但接近植入物以最小化通信距离。

