



US 20080139894A1

(19) **United States**

(12) **Patent Application Publication**
Szydlo-Moore et al.

(10) **Pub. No.: US 2008/0139894 A1**
(43) **Pub. Date: Jun. 12, 2008**

(54) **DEVICES AND SYSTEMS FOR REMOTE
PHYSIOLOGICAL MONITORING**

Publication Classification

(76) Inventors: **Joanna Szydlo-Moore**, Everett,
WA (US); **Shawn H. Park**,
Cerritos, CA (US)

(51) **Int. Cl.**
A61B 5/00 (2006.01)
(52) **U.S. Cl.** **600/300**

Correspondence Address:
DUKE W. YEE
YEE & ASSOCIATES, P.C., P.O. BOX 802333
DALLAS, TX 75380

(57) **ABSTRACT**

Devices and systems are provided for the remote monitoring of physiological parameters of a patient. An exemplary wireless physiological monitoring device comprises a substrate formed of a flexible biocompatible material. The substrate has a surface for affixing to the skin of a patient. A wireless data transmission device, a biosensor, and a power source are integrated with the substrate. The biosensor is configured to measure a physiological parameter. Flexible conductors are integrated with the substrate and are configured to electrically couple the biosensor and the power source with the data transmission device.

(21) Appl. No.: **11/608,777**

(22) Filed: **Dec. 8, 2006**

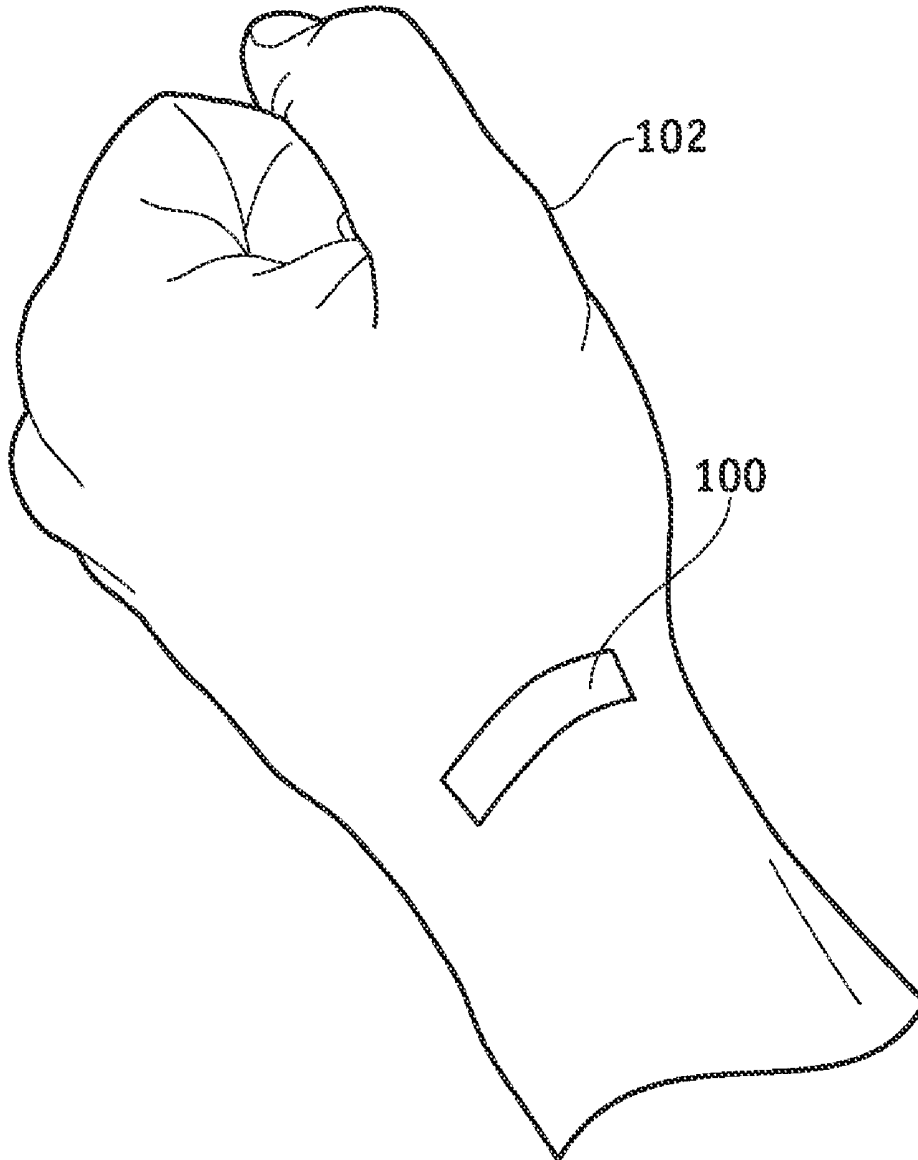

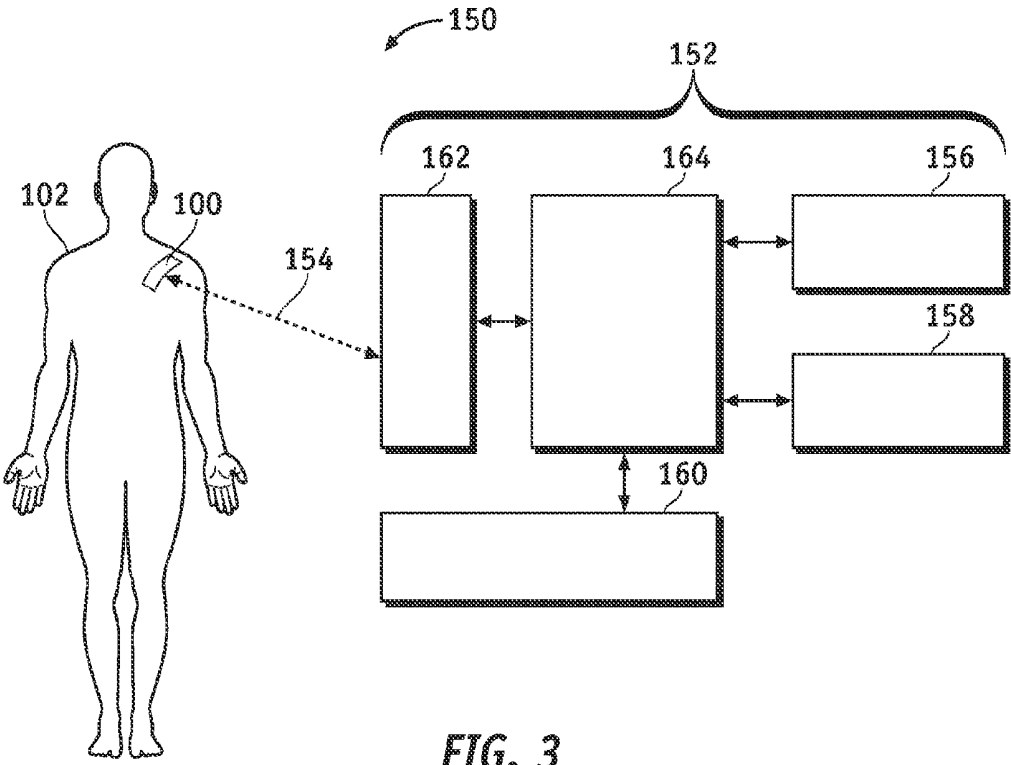
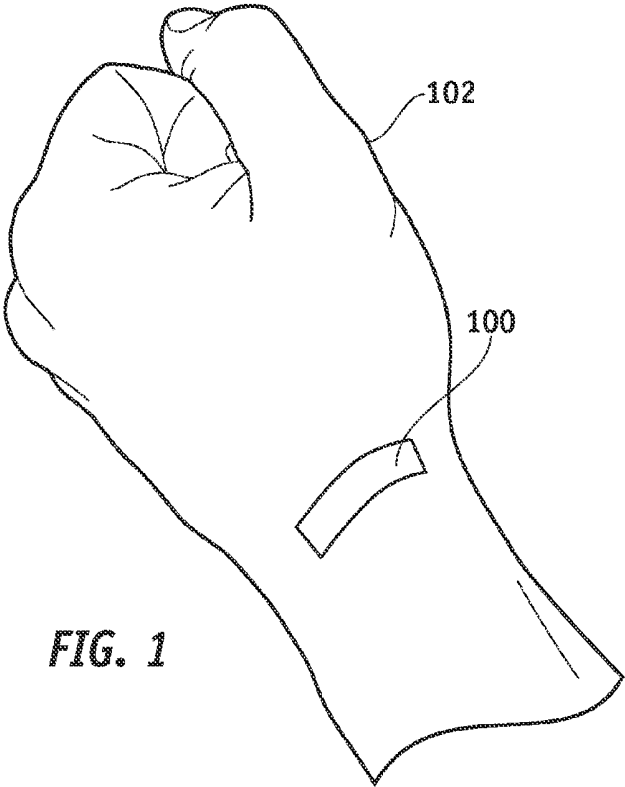

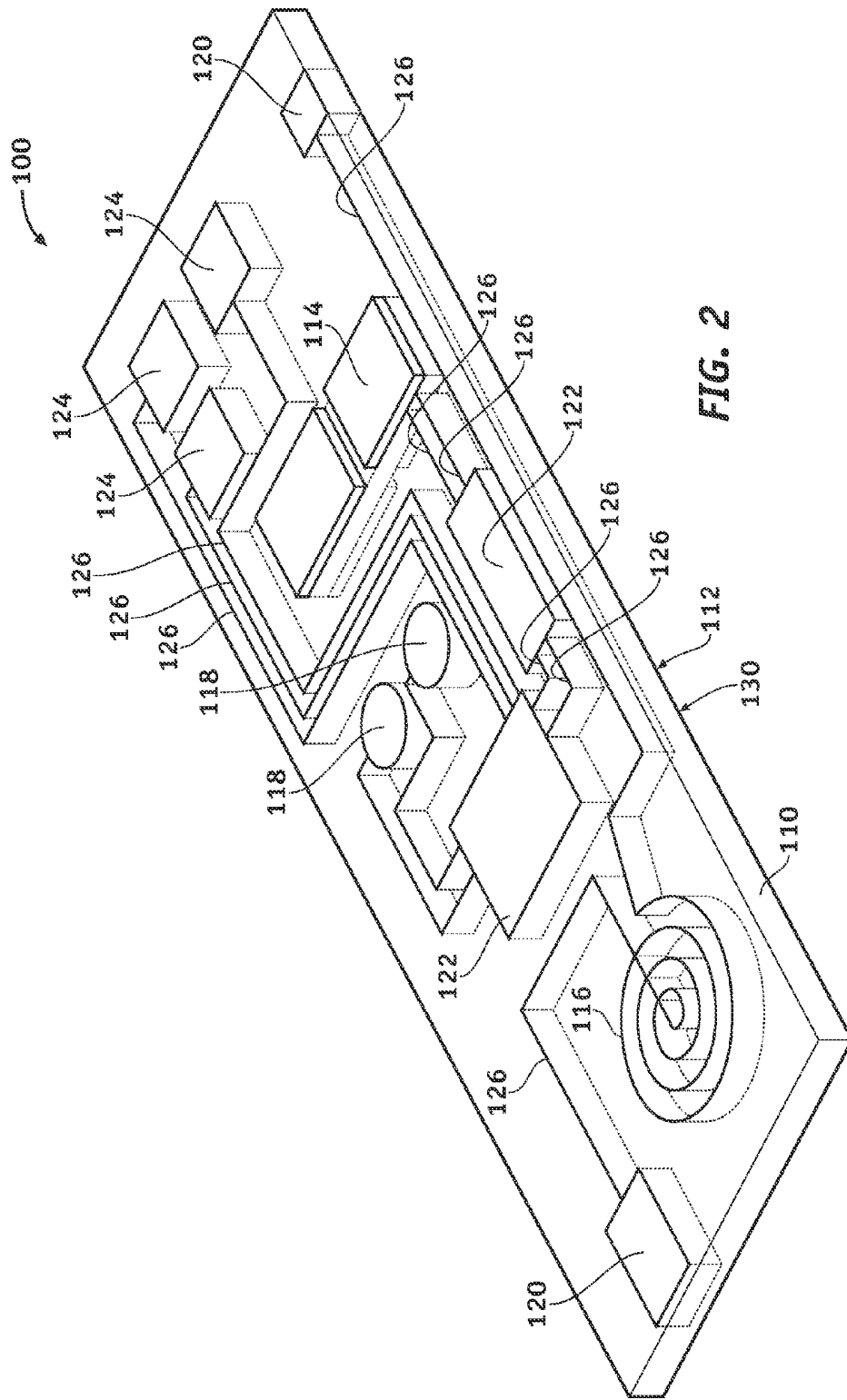

DEVICES AND SYSTEMS FOR REMOTE PHYSIOLOGICAL MONITORING

TECHNICAL FIELD

[0001] The embodiments described herein generally relate to physiological monitoring systems, and more particularly relate to portable, non-invasive devices for measuring and monitoring physiological parameters and to systems using such devices for remote monitoring.

BACKGROUND

[0002] Physiological monitoring of an animal, such as a human, typically includes the monitoring of vital signs, such as pulse, respiration, and blood pressure. Other physiological data of interest may include blood chemistry information, body temperature, hydration levels, sweat electrolyte information, electrocardiogram data, and the like. This information can be used to assess the health of the intended subject, the physical condition of the subject, or the subject's ability to participate in a given activity.

[0003] This physiological data can be relatively easy to measure and monitor in a doctor's or veterinarian's office or hospital. In those instances, the patient can be connected to physiological measurement devices directly coupled to central stations that monitor and record patient data. Such physiological measurement devices typically are dedicated devices that assess a single or related group of physiological parameters. However, various physiological data is often helpful, if not required, when a subject is not in a medical office or hospital and cannot be connected to central monitoring stations, such as when in transit, as from an emergency or accident, or when in a war zone site, where connection to cumbersome monitoring devices is not practical. For example, higher survival rates of soldiers may be possible if various physiological data could be remotely monitored by military medics when the soldiers are on battlefields and when being transported to medical facilities or extended care facilities.

[0004] Non-invasive and remote monitoring of various physiological parameters also is helpful to determine if a subject is in condition to perform a selected activity. For example, physiological data could aid in determining if a pilot's physical condition could inhibit her ability to safely fly an aircraft. Similarly, the non-invasive remote monitoring of physiological data of astronauts could indicate remedial measures that the astronauts could take to maintain or improve their health while in space. Non-invasive and remote physiological monitoring systems could also measure various physiological data of automobile drivers or other heavy-machinery operators and transmit that data to devices that would disable the engines of the machinery when high blood alcohol is indicated.

[0005] Non-invasive and remote monitoring also is useful to medical personnel to monitor a patient's physiological state while the patient is at home, at a senior center, or otherwise away from a hospital or doctor's office setting. Physiological parameters of the patient could be measured and transmitted to a remote medical office or veterinarian facility, thus minimizing the need for numerous doctor, veterinarian, or hospital visits. Remote monitoring also could indicate whether a patient, whose location is unknown, is dead or alive, such as when a patient is lost under rubble caused by an earthquake, hurricane, or man-made disaster.

[0006] However, to be practical in the above-described situations, a device capable of non-invasive and remote monitoring of a patient should be relatively small, comfortable, and wearable for the patient for extended periods. Present-day monitoring devices are often large, cumbersome, stiff, and restrictive and do not allow the patient to move comfortably. Such monitoring devices often extend multiple electronic or biosensor leads from a monitoring station to a patient or require cuffs or bands to be wrapped around the patient. To that end, present-day monitoring devices typically do not have their own power sources, and are required to be connected to an electronic wall socket or generator to operate. This prevents a patient from moving freely, as may be required on a battlefield, when undertaking to operate an aircraft, automobile, or heavy machinery, or even when at home.

[0007] Accordingly, it is desirable to provide a small, flexible, non-invasive device for physiological monitoring that permits a patient to move freely and comfortably. In addition, it is desirable to provide a wearable biocybernetic monitoring device that permits wireless remote monitoring of physiological parameters of a patient. It also is desirable to provide a physiological monitoring system that utilizes such devices. Furthermore, other desirable features and characteristics will become apparent from the subsequent detailed description of the embodiments and the appended claims, taken in conjunction with the accompanying drawings and the foregoing technical field and background.

BRIEF SUMMARY

[0008] In accordance with an exemplary embodiment, a wireless physiological monitoring device comprises a substrate formed of a flexible biocompatible material, wherein the substrate has a surface for affixing to the skin of a patient. A wireless data transmission device, a biosensor, and a power source are integrated with the substrate. The biosensor is configured to measure a physiological parameter. Flexible conductors are integrated with the substrate and are configured to electrically couple the biosensor with the data transmission device and the power source with the data transmission device.

[0009] In accordance with another exemplary embodiment, a wireless device for the remote monitoring of physiological parameters of a patient comprises a biocompatible substrate having a surface configured for the removable affixing to the skin of the patient. A data transmission system for wirelessly transmitting data to a remote data transceiver is physically coupled to the substrate. A power source is configured to supply power to the data transmission system and a light-emitting diode is integrated with the substrate and powered by the power source. Flexible conductors electrically couple the light-emitting diode and the data transmission system and electrically couple the power source and the data transmission system.

[0010] In accordance with a further embodiment, a physiological monitoring system comprises a central monitoring station having a transceiver for receiving data transmitted wirelessly and a wireless device for the monitoring of physiological parameters of a patient. The wireless device comprises a substrate formed of a flexible biocompatible material. The substrate has an adhesive surface for affixing to the skin of a patient. A wireless data transmission device is integrated with the substrate and is configured to wirelessly transmit data to the transceiver of the central monitoring station. A

biosensor is integrated with the substrate and configured to measure a physiological parameter. A power source is integrated with the substrate and flexible conductors are integrated with the substrate and are configured to electrically couple the biosensor and the power source with the data transmission device.

BRIEF DESCRIPTION OF THE DRAWINGS

[0011] Various embodiments will hereinafter be described in conjunction with the following drawing figures, wherein like numerals denote like elements, and wherein:

[0012] FIG. 1 is an isometric view of a patient wearing a physiological monitoring device, in accordance with an exemplary embodiment;

[0013] FIG. 2 is an isometric view of a patient monitoring device, in accordance with an exemplary embodiment; and

[0014] FIG. 3 is a schematic illustration of a physiological monitoring system, in accordance with an exemplary embodiment.

DETAILED DESCRIPTION

[0015] The following detailed description is merely exemplary in nature and is not intended to limit the described embodiments or the application and uses of the described embodiments. Furthermore, there is no intention to be bound by any expressed or implied theory presented in the preceding technical field, background, brief summary or the following detailed description.

[0016] Referring to FIG. 1, in accordance with an exemplary embodiment, a flexible, non-invasive device 100 for remote physiological monitoring of an animal, such as a human 102, is configured for affixing to the skin of the animal. While it will be understood that device 100 can be used to monitor physiological parameters of any animal that is large enough for affixing of device 100 thereto and from which physiological data may be obtained, such as an animal under veterinarian care or a human being, for convenience the animal will be referred to herein as "the patient". Device 100 may be affixed to any part of the patient from which a desired physiological parameter can be obtained. For example, if pulse of a human is a physiological parameter to be monitored, preferably device 100 is applied to a pulse point of the patient, such as the underside of the wrist or on the neck proximate to the jugular vein.

[0017] FIG. 2 is a close-up isometric view of device 100 and the components thereof, in accordance with an exemplary embodiment. Device 100 comprises a substrate 110 that is formed of a flexible, biocompatible material having low moisture permeability. Examples of materials from which to fabricate substrate 110 include biocompatible polymers, such as, for example, polyimide or polydimethylsiloxane (PDMS), or other biocompatible materials such as silicon. In a preferred exemplary embodiment, substrate 110 is formed of parylene, particularly parylene C. Parylene is a United States Pharmacopoeia (USP) Class VI biocompatible polymer that can be deposited through a highly conformal vapor deposition process. Parylene is strong and flexible (Young's modulus of approximately 4 GPa), has a low dielectric constant (approximately 3), has a high volume resistivity ($>10^{16}$ ohm-cm), has low moisture permeability, and is easily manipulated using standard microfabrication techniques such as reactive ion etching (RIE). Alternatively, substrate 110 can be formed of any combination of the above materials. Substrate 110 can

have any suitable shape, including rectangular, square, circular, oval, and the like. While substrate 110 can have any size suitable for supporting the various components of device 100, discussed in more detail below, preferably substrate 110 is of a size that is comfortable and non-irritating to the patient and that permits free movement of the patient for extended time periods.

[0018] Substrate 110 has a surface 112 that is configured so that device 100 can be affixed to the skin of a patient. For example, surface 112 may itself be adhesive or a biocompatible adhesive 130 may be disposed on surface 112. Biocompatible adhesives are well-known and, accordingly, will not be discussed in further detail herein. By affixing device 100 to the patient with an adhesive surface 112, substantial contact between device 100 and the skin of the patient can be made so that physiological parameters are accurately measured. In addition, the patient can comfortably wear the device without being restricted by cumbersome bands or straps. Further, device 100 can be easily removed from the patient when monitoring is complete or when the power source (described in more detail below) is depleted.

[0019] In an exemplary embodiment, device 100 comprises a power source 114 that is integrated with substrate 110. As used herein, the term "integrated with" substrate 110 means to be formed or embedded within substrate 110, to be disposed or formed on or overlying substrate 110, or otherwise to be physically coupled to substrate 110. Power source 114 can be any power source that can provide sufficient energy to power the various components of device 100 for a period of time over which the monitoring of physiological parameters is to be conducted. In one exemplary embodiment, power source 114 is one or more small batteries, such as, for example, one or more small lithium batteries. In another exemplary embodiment, power source 114 can include one or more kinetic energy converters, such as, for example, piezoelectric transducers, thermoelectric generators, such as those thermoelectric generators that generate electricity by using temperature difference between the wearer's skin and outside air, and/or electromagnetic generators, such as those electromagnetic generators that generate electricity from rotational torque. If the power source of patient monitoring device 100 is depleted and not recharged, device 100 can be configured as a disposable device that is easily removed from the patient and, optionally, replaced by a new patient monitoring device 100.

[0020] In accordance with another exemplary embodiment, device 100 comprises a data transmission system 116 for transmitting physiological parameter data to remote monitoring stations (not shown). Data transmission system 116 is integrated with substrate 110 and can be powered by power source 114. Preferably, data transmission system 116 is a flexible system that does not substantially interfere with or hinder the flexibility of substrate 110. Data transmission system 116 can be, for example, a radio-frequency (RF) system, such as a flexible RF coil system illustrated in FIG. 2, or an infrared (IR) communication system. A flexible RF coil system may be fabricated, for example, by sandwiching an insulating layer of polymer, such as parylene, between two metal layers with a polymer coating on each side of the metal layers. The polymer isolates the coil from the environment while at the same time insuring the material's biocompatibility. Data transmission system 116 also may be configured for power transmission to charge or recharge power source 114.

[0021] Device 100, in accordance with an exemplary embodiment, also may comprise any number and type of biosensors 118. For example, device 100 may comprise blood oxygenation/saturation detectors (blood oximeters) 118 that are integrated with substrate 110. The blood oximeters 118 can be powered by power source 114 and are in electrical communication with data transmission system 116. In this regard, when blood oxygen levels are measured by blood oximeters 118, the blood oxygen levels can be electronically transmitted to data transmission device 116 to be wirelessly transmitted to a remote central monitoring station (not shown). Alternatively, biosensors 118 may be sensors configured to measure one or more of body temperature, hydration levels, sweat electrolyte information, electrocardiogram data, heart rate, and the like.

[0022] In another exemplary embodiment, device 100 may comprise one or more flexible multi-electrode arrays 120 that are integrated with substrate 110 and powered by power source 114. The multi-electrode arrays 120 can be made with metal conductive lines sandwiched on each side by a flexible polymer, such as parylene. The electrode area can be exposed using standard photolithography and plasma-etching techniques, as are well known in the industry. The multi-electrode array 120 may be integral with a biosensor 118 or may be a stand-alone component. The multi-electrode arrays 120 can sense the biopotentials at the site of application of device 100 and from these biopotentials indicate physiological parameters. For example, a comparison and correlation of these biopotentials could generate heart rate information and/or determine hydration of the body through the analysis of the conductivity of the sweat underlying device 100. Accordingly, when two or more multi-electrode arrays are used, the arrays are separated from each other by a suitable distance so that the arrays can function properly.

[0023] Device 100 may further comprise analog/digital application-specific integrated circuits (ASICs) 122 manufactured to perform dedicated functions. For example, the ASICs 122 can be configured as biosensors to measure heart rate, body temperature, or other physiological parameter. The ASICs 122 are integrated with substrate 110, can be powered by power source 114, and are configured to electronically transmit the physiological parameters to data transmission system 116 for transmission to a remote monitoring station.

[0024] Device 100 may also comprise other discrete components that are integrated with substrate 110. For example, light-emitting diodes (LEDs) 124 may be integrated with substrate 110 to provide device functionality monitoring, visual health status, communication-link indication, and the like. Similar to the other components described above, LEDs 124 may be powered by power source 114 and may be in electrical communication with data transmission system 116. Other discrete components may include, for example, chip capacitors, central processing units (CPUs), microprocessors and/or controllers, memory modules, analog-to-digital converters, and the like.

[0025] The various components of device 110 may be interconnected by flexible conductors 126 integrated with substrate 110. The flexible conductors can be fabricated using any known flexible packaging technique, such as, for example, a chip-level integrated interconnect (CL-I²) technique. By using flexible conductors for interconnection of the components of device 100, device 100 maintains the flexibility of substrate 110, can conform to any suitable part of patient's body, and can be comfortably worn by the patient for

extended periods of time. While FIG. 2 illustrates an embodiment of a patient monitoring device 100 comprising various components and an arrangement of those components, it will be understood that various other embodiments of device are not so limited and may comprise any number and type of the above-described components arranged in any suitable configuration.

[0026] Referring to FIG. 3, a physiological monitoring system 150 for remote monitoring of physiological parameters of a patient includes a patient monitoring device 100 affixed to a patient 102, and a central or base station 152. Patient monitoring device 100 and central station 152 communicate via, for example, a wireless communication link, indicated by dotted line 154, such as a radio frequency (RF) or infrared (IR) communication system. Central station 152 typically includes a wireless transceiver 162, a display system 156, such as, for example, a computer monitor, a printing device 158, and a database system 160. During patient monitoring, physiological data, such as ECG, pulse, body temperature, hydration, blood chemistry, sweat electrolyte levels, and the like are measured by the various biosensors and other components of device 100 described above, and are transmitted wirelessly to central station 152 by wireless communication link 154. Once received by the wireless transceiver 162 of central station 152, the physiological data of patient 102 can be displayed on monitor 156 or printed on hard copy by printer 158 for viewing by medical personnel. The physiological data also can be stored in database system 160 for later retrieval or data manipulation. Central station 152 also can transmit power, instructions, or data to device 100 via wireless communications link 154.

[0027] Accordingly, a patient monitoring device and physiological monitoring system that provide for the remote monitoring of physiological parameters of a patient have been provided. The device is flexible and noninvasive, and permits free movement and mobility of the patient while also providing for the transmission of physiological parameters to a remote monitoring location. The physiological parameters can indicate the general health or physical condition of a patient to medical personnel that are not present with the patient. While at least one exemplary embodiment has been presented in the foregoing detailed description, it should be appreciated that a vast number of variations exist. It should also be appreciated that the exemplary embodiment or exemplary embodiments are only examples, and are not intended to limit the scope, applicability, or configuration of the described embodiments in any way. Rather, the foregoing detailed description will provide those skilled in the art with a convenient road map for implementing the exemplary embodiment or exemplary embodiments. It should be understood that various changes can be made in the function and arrangement of elements without departing from the scope as set forth in the appended claims and the legal equivalents thereof.

What is claimed is:

1. A wireless physiological monitoring device comprising:
 - a substrate formed of a flexible biocompatible material, wherein the substrate has a surface for affixing to the skin of a patient;
 - a wireless data transmission device integrated with the substrate;
 - a biosensor integrated with the substrate and configured to measure a physiological parameter;
 - a power source integrated with the substrate; and

- flexible conductors integrated with the substrate and configured to electrically couple the biosensor and the power source with the data transmission device.
2. The wireless physiological monitoring device of claim 1, wherein the substrate comprises polyimide, polydimethylsiloxane, parylene, or a combination thereof.
3. The wireless physiological monitoring device of claim 1, wherein the surface of the substrate comprises a biocompatible adhesive disposed thereon.
4. The wireless physiological monitoring device of claim 1, wherein the power source comprises a battery.
5. The wireless physiological monitoring device of claim 1, wherein the power source comprises a piezoelectric transducer, a thermoelectric generator, or an electromagnetic generator.
6. The wireless physiological monitoring device of claim 1, wherein the data transmission device is a radio-frequency system or an infrared communication system.
7. The wireless physiological monitoring device of claim 1, wherein the radio-frequency system is a flexible radio-frequency RF coil system.
8. The wireless physiological monitoring device of claim 1, wherein the biosensor is configured to measure blood oxygen levels, blood chemistry, heart rate, body temperature, hydration levels, sweat electrolyte information, electrocardiogram data, or any combination thereof.
9. The wireless physiological monitoring device of claim 1, further comprising a multi-electrode array integrated with the substrate and configured to measure a biopotential of a patient.
10. The wireless physiological monitoring device of claim 1, further comprising a light-emitting diode integrated with the substrate and powered by the power source.
11. The wireless physiological monitoring device of claim 1, further comprising an application-specific integrated circuit (ASIC).
12. A wireless device for the remote monitoring of physiological parameters of a patient, the device comprising:
 a biocompatible substrate having a surface configured for the removable affixing to the skin of the patient;
 a data transmission system for wirelessly transmitting data to a remote data transceiver, wherein the data transmission system is physically coupled to the substrate;
 a power source configured to supply power to the data transmission system;
 a light-emitting diode integrated with the substrate and powered by the power source; and
 flexible conductors that electrically couple the light-emitting diode and the power source with the data transmission system.
13. The wireless device of claim 12, further comprising a biocompatible adhesive disposed on the surface of the biocompatible substrate.
14. The wireless device of claim 12, wherein the biocompatible substrate comprises polyimide, polydimethylsiloxane, parylene, or a combination thereof.
15. The wireless device of claim 14, wherein the biocompatible substrate comprises parylene C.
16. The wireless device of claim 12, further comprising a biosensor integrated with the substrate.
17. The wireless device of claim 16, wherein the biosensor is configured to measure blood oxygen levels, blood chemistry, heart rate, body temperature, hydration levels, sweat electrolyte information, electrocardiogram data, or any combination thereof.
18. The wireless device of claim 12, further comprising a multi-electrode array configured to measure a biopotential of the patient.
19. A physiological monitoring system comprising:
 a central monitoring station having a transceiver for receiving data transmitted wirelessly; and
 a wireless device for the monitoring of physiological parameters of a patient, wherein the wireless device comprises;
 a substrate formed of a flexible biocompatible material, wherein the substrate has an adhesive surface for affixing to the skin of a patient;
 a wireless data transmission device integrated with the substrate and configured to wirelessly transmit data to the transceiver of the central monitoring station;
 a biosensor integrated with the substrate and configured to measure a physiological parameter;
 a power source integrated with the substrate; and
 flexible conductors integrated with the substrate and configured to electrically couple the biosensor and the power source with the data transmission device.
20. The physiological monitoring system of claim 19, wherein the wireless data transmission device is a radio-frequency transmission device or an infrared transmission device.
21. The physiological monitoring system of claim 19, wherein the substrate comprises polyimide, polydimethylsiloxane, parylene, or a combination thereof.
22. The physiological monitoring system of claim 19, further comprising a light-emitting diode integrated with the substrate and powered by the power source.

* * * * *

专利名称(译)	用于远程生理监测的装置和系统		
公开(公告)号	US20080139894A1	公开(公告)日	2008-06-12
申请号	US11/608777	申请日	2006-12-08
[标]申请(专利权)人(译)	SZYDLO MOORE JOANNA PARK SHAWN ^ h		
申请(专利权)人(译)	SZYDLO-MOORE JOANNA PARK SHAWN ^ h		
当前申请(专利权)人(译)	SZYDLO-MOORE JOANNA PARK SHAWN ^ h		
[标]发明人	SZYDLO MOORE JOANNA PARK SHAWN H		
发明人	SZYDLO-MOORE, JOANNA PARK, SHAWN H.		
IPC分类号	A61B5/00		
CPC分类号	A61B5/0002 A61B5/04085 A61B5/6832 A61B8/4236 A61B5/6833		
其他公开文献	US8979755		
外部链接	Espacenet USPTO		

摘要(译)

提供了用于远程监测患者的生理参数的装置和系统。示例性无线生理监测装置包括由柔性生物相容性材料形成的基板。基底具有用于固定到患者皮肤的表面。无线数据传输设备，生物传感器和电源与基板集成在一起。生物传感器配置为测量生理参数。柔性导体与基板集成在一起，并配置成将生物传感器和电源与数据传输装置电耦合。

