



(19) **United States**

(12) **Patent Application Publication**

Baker, JR. et al.

(10) **Pub. No.: US 2006/0135860 A1**

(43) **Pub. Date:**

Jun. 22, 2006

(54) **SIGNAL QUALITY METRICS DESIGN FOR QUALIFYING DATA FOR A PHYSIOLOGICAL MONITOR**

(52) **U.S. Cl.** 600/310; 600/323; 600/300

(76) **Inventors:** **Clark R. Baker JR.**, Castro Valley, CA (US); **Edward M. Richards**, Pleasanton, CA (US)

(57) **ABSTRACT**

Correspondence Address:
Michael G. Fletcher
FLETCHER YODER
P.O. Box 692289
Houston, TX 77269-2289 (US)

A method and a device for determining the quality of signal used for measuring a physiological parameter. One embodiment of the present invention is directed towards a pulse oximeter, where the measured physiological parameter includes a patient's pulse rate and blood oxygen saturation. The signal quality, which is indicative of the accuracy and reliability of the measured physiological parameter, is calculated by combining a plurality of signal quality indicators, each of which is an indicator of a quality of the measured signal. The value of the signal quality metric is compared to a threshold and based on this comparison various decisions are made by the medical device. One decision is directed towards deciding whether or not to display the measured physiological parameter, to ensure that only accurate measured values are displayed. Another decision is directed towards providing feedback to guide the clinician to adjust the location of the sensor to a more suitable tissue location.

(21) **Appl. No.:** 11/293,714

(22) **Filed:** Dec. 2, 2005

Related U.S. Application Data

(63) Continuation of application No. 10/341,318, filed on Jan. 10, 2003, now Pat. No. 7,006,856.

Publication Classification

(51) **Int. Cl.**
A61B 5/00 (2006.01)

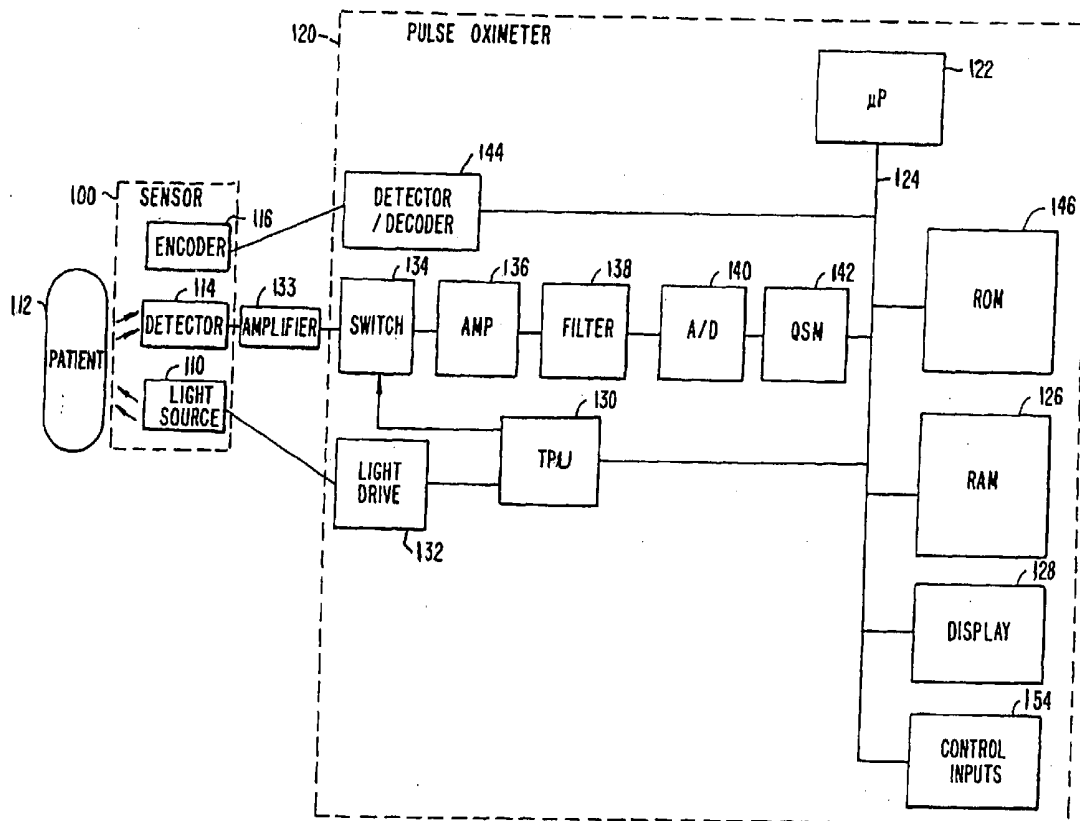

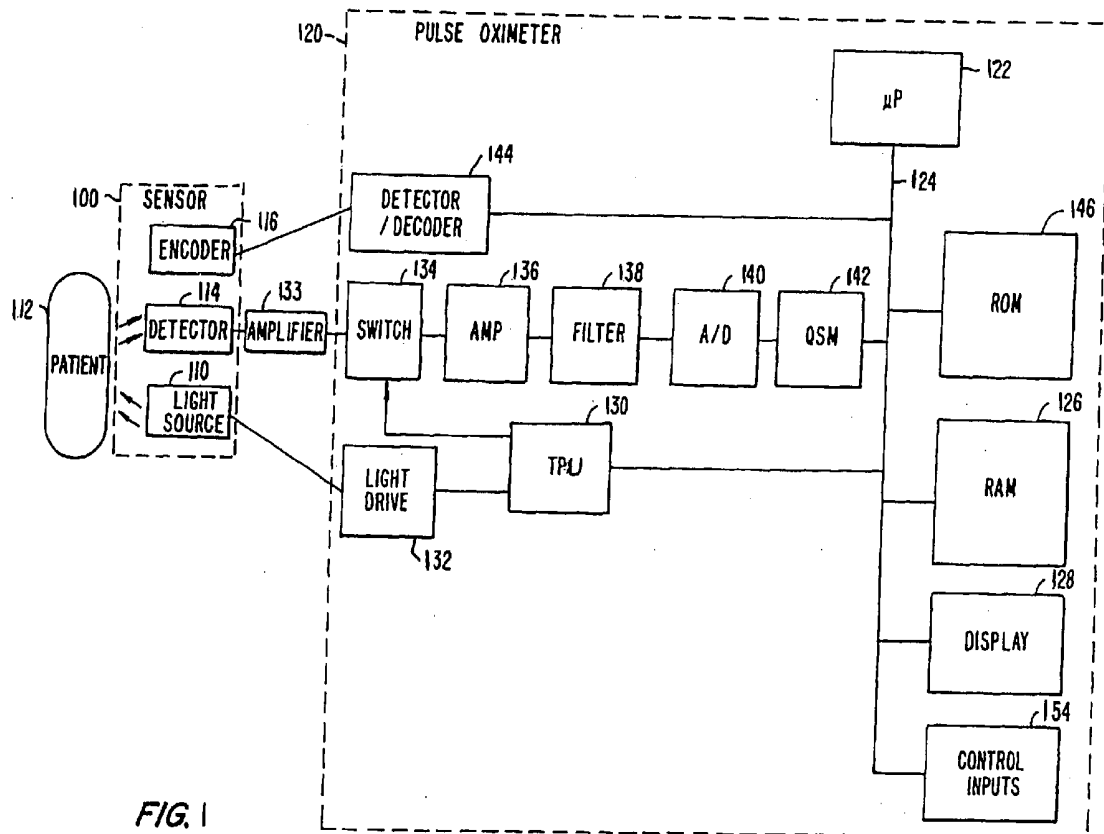

FIG. 1

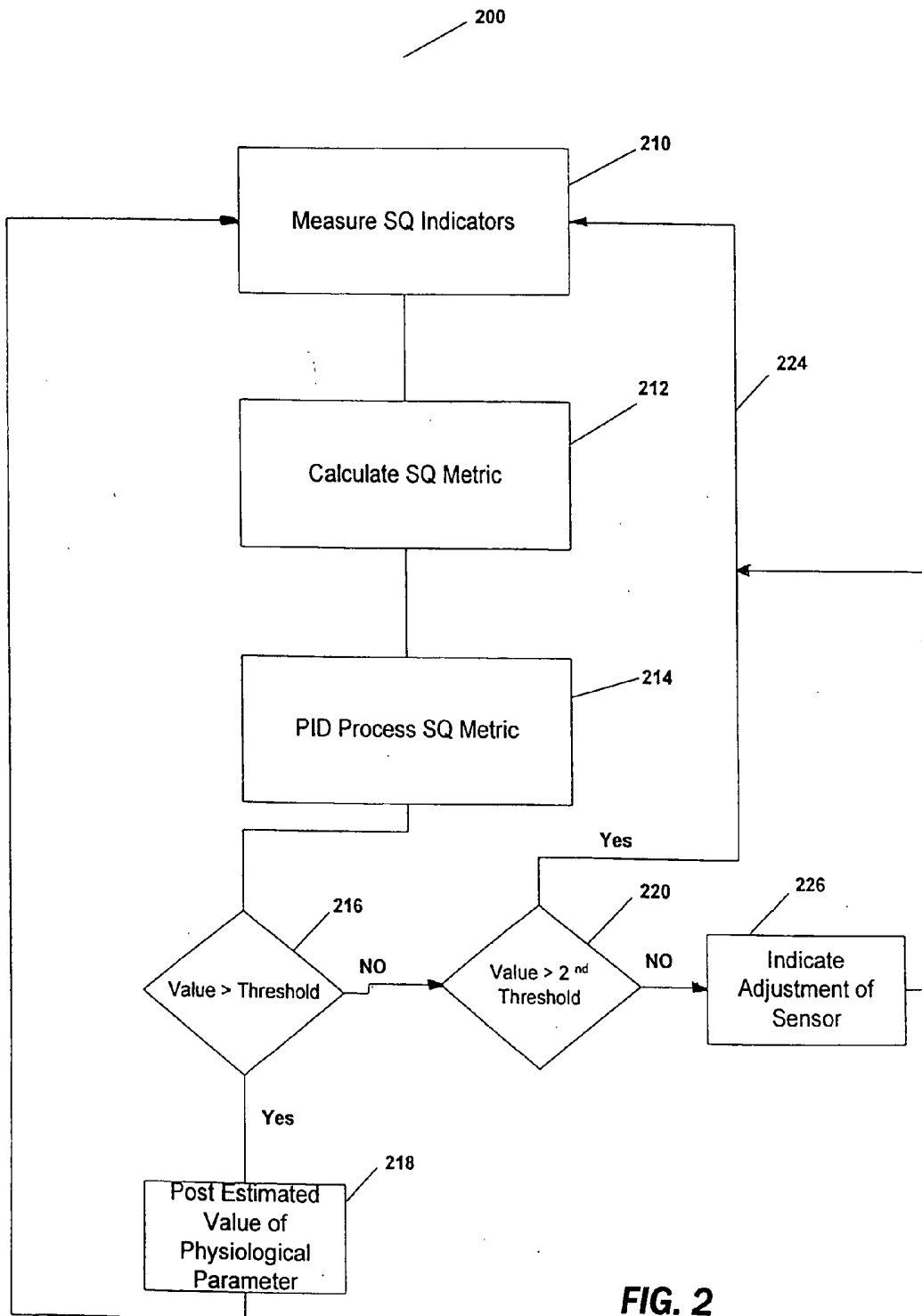

FIG. 2

SIGNAL QUALITY METRICS DESIGN FOR QUALIFYING DATA FOR A PHYSIOLOGICAL MONITOR

BACKGROUND OF THE INVENTION

[0001] The present invention relates to physiological monitoring equipment and, in particular, monitoring equipment that include processes for quantitatively estimating the quality of the detected signals corresponding to physiological measurements and which provide appropriate feedback to the clinician based on that estimate of signal quality.

[0002] Typically, for physiological monitoring instruments, the instrument is unable to accurately determine the accuracy and reliability, or a quality of a signal obtained from the sensor. An example of such physiological monitoring instrument is a pulse oximeter. Pulse oximetry is typically used to measure various blood characteristics including the blood oxygen saturation of hemoglobin in arterial blood and the pulse rate of the patient.

[0003] Measurement of these characteristics has been accomplished by use of a non-invasive sensor that passes light through a portion of a patient's blood perfused tissue and photo-electrically senses the absorption and scattering of light in such tissue. The amount of light absorbed and scattered is then used to estimate the amount of blood constituent in the tissue using various algorithms known in the art. The "pulse" in pulse oximetry comes from the time varying amount of arterial blood in the tissue during a cardiac cycle. The signal processed from the sensed optical measurement is the familiar plethysmographic waveform due to cyclic light attenuation.

[0004] The accuracy of the estimates of the blood flow characteristics depends on a number of factors. For example, the light absorption characteristics typically vary from patient to patient depending on their physiology. Moreover, the absorption characteristics vary depending on the location (e.g., the foot, finger, ear, and so on) where the sensor is applied, and whether there are objects interfering between the sensor and the tissue location (e.g., hair, nail polish, etc.). Further, the light absorption characteristics vary depending on the design or model of the sensor. Also, the light absorption characteristics of any single sensor design vary from sensor to sensor (e.g., due to different characteristics of the light sources or photo-detector, or both). The clinician applying the sensor correctly or incorrectly may also have a large impact in the results, for example, by loosely or firmly applying the sensor or by applying the sensor to a body part which is inappropriate for the particular sensor design being used.

[0005] The clinician needs to know how accurate or reliable a reading is being provided by the instrument. Moreover, the instrument should ideally provide measurements that are accurate and reliable. A measure of the reliability and accuracy of a physiological measurement can be the quality of the signal. Although quality is a rather nebulous term, generally speaking, high quality signals are indicative of more reliable and more accurate physiological measurements and conversely, low quality signals are indicative of less reliable and accurate signals.

[0006] Some oximeters devices qualify measurements before displaying them on the monitor, by comparing the

measured signals to various phenomenologically-derived criteria. These oximeters qualify the signal by making an assessment of its accuracy and only display values of estimated parameters when the signal quality meets certain criteria. The disadvantage of such approaches is that no feedback is provided to the clinician regarding what the clinician should do to improve the measurements. Worse yet, if the signal quality is deemed poor, and a decision is made by the device to not display the measured value, then the clinician is left with no more information than if the device was never used in the first place, which can be frustrating. Most typically, the clinician will end up removing the sensor from a particular tissue location to re-attach it to another location and heuristically repeats this process until more reliable measurements, deemed worthy of being displayed are provided by the instrument. The time duration where a measured value is displayed is known as the posting time. An ideal oximeter provides both accurate measurements and high posting times. While some instruments make estimates of signal quality, there still exists a need for improvements in this area; improvements that assess the quality of the signal while maintaining or increasing the posting times of the measured values. There is therefore a need for an improved and more quantitative assessment of signal quality. There is also a need for the monitoring equipment to guide the clinician to make necessary adjustments to improve the signal quality.

[0007] The issues related to obtaining high quality signals which are indicative of reliable and accurate measurements of critical physiological parameters, are further compounded when the sensor is "blindly" placed. A blindly placed sensor is one that is placed adjacent to a tissue location that is not readily observable by the clinician. An example of such a blind sensor placement is when a clinician uses a fetal pulse oximeter. The fetal pulse oximetry sensor is placed through the cervix during labor. The sensor, which is supposed to lie between the cheek of the fetus and the wall of the uterus, measures the fetus' blood oxygen levels. The sensor is connected to a monitor that displays the fetus' current blood oxygen levels. During the course of monitoring the quality of the signal obtained can vary significantly and rapidly. This change in the quality of the signal can be caused by sensor-to-fetus positioning irrespective of actual fetus physiological condition, resulting in spurious readings and interrupted posting times over relatively short time frames. Monitoring the heart rate of the fetus is an indirect way of assessing the amount of oxygen in the fetus' blood, which allows a clinician to determine whether the fetus is in distress during labor. Knowing the fetus' blood oxygen level during labor, and hence whether the fetus is in distress or not, allows a clinician to better decide as to whether to perform a cesarean versus letting the labor progress. Therefore, with a blindly placed sensor, and especially one used in a fetal pulse oximetry, the need for an improved assessment of signal quality is heightened. Moreover, just as in non-blindly placed sensors, there is also a need for the medical device to provide guidance to a clinician to improve the quality of the signal when the signal quality is so low as to indicate an inaccurate and/or unreliable estimate of a measured value.

BRIEF SUMMARY OF THE INVENTION

[0008] The present invention provides a method and a device for determining the quality of signal used for mea-

asuring a physiological parameter. One embodiment of the present invention is directed towards a pulse oximeter, where the measured physiological parameter includes a patient's pulse rate and blood oxygen saturation. The signal quality, which is indicative of the accuracy and reliability of the measured physiological parameter, is calculated by combining a plurality of signal quality indicators, each of which is an indicator of a quality of the measured signal. The value of the signal quality metric is compared to a threshold and based on this comparison various decisions are made by the medical device. One decision is directed towards deciding whether or not to display the measured physiological parameter, to ensure that only accurate measured values are displayed. Another decision is directed towards providing feedback to guide the clinician to adjust the location of the sensor to a more suitable tissue location.

[0009] In a pulse oximeter embodiment, the signal quality indicators of the present invention include: a signal measure indicative of the degree of similarity of an infrared and red waveforms; a signal measure indicative of a low light level; a signal measure indicative of an arterial pulse shape; a signal measure indicative of the high frequency signal component in the measure value; a signal measure indicative of a consistency of a pulse shape; a signal measure indicative of an arterial pulse amplitude; a signal measure indicative of modulation ratios of red to infrared modulations and a signal measure indicative of a period of an arterial pulse. These various indicators provide for an indirect assessments of the presence of known error sources in pulse oximetry measurements, which include optical interference between the sensor and the tissue location; light modulation by other than the patient's pulsatile tissue bed; physical movement of the patient and improper tissue-to-sensor positioning.

[0010] The signal quality is calculated periodically, and hence can vary significantly and rapidly. In order to temper the decision making algorithm's response to changes in the calculated signal quality, certain embodiments of the present invention base the decisions to display a measured value and/or the decisions to guide the clinician, by comparing a PID-processed (proportional, integral and derivative) signal quality value to a threshold. PID processing is known in the controls arena and provides several advantages. In the context of a medical device and specifically a pulse oximeter device, the use of PID processing will ensure that a small magnitude, short time change in signal quality signal is reacted to quickly, preventing spurious responses, or delayed responses that could result in the display of inaccurate information. Further, a large magnitude signal quality change is responded to in a shorter period of time, and a slower long term change in signal quality is responded to in an adequate time frame to give the clinician sufficient timely information to work with.

[0011] For a further understanding of the nature and advantages of the invention, reference should be made to the following description taken in conjunction with the accompanying drawings.

BRIEF DESCRIPTION OF THE DRAWINGS

[0012] **FIG. 1** is a block diagram of an exemplary oximeter.

[0013] **FIG. 2** is a flow chart showing an embodiment of the decision making algorithm of the present invention.

DETAILED DESCRIPTION OF THE INVENTION

[0014] Embodiments of the present invention describe a physiological monitor and sensor incorporating methods and systems that quantitatively estimate signal quality, and based on that estimate of signal quality decide whether to display the measured physiologic parameter and/or provide feedback to guide the clinician to adjust the location of the sensor. The signal quality estimate is based on the measurement of a plurality of signal quality indicators which when combined provide a quantitative measure of signal quality.

[0015] The invention is particularly applicable to and will be explained by reference to measurements of oxygen saturation of hemoglobin in arterial blood and patient heart rate, as in pulse oximeter monitors and pulse oximetry sensors. However, it should be realized the invention is equally applicable to any generalized patient monitor and associated patient sensor, such as ECG, blood pressure, temperature, etc., and is not limited to use only with oximetry or pulse oximetry. A brief description of pulse oximeters is provided below.

[0016] **Pulse Oximeters**

[0017] As described above, pulse oximeters are typically used to measure various blood flow characteristics including the blood oxygen saturation of hemoglobin in arterial blood and the heartbeat of a patient. Measurement of these characteristics has been accomplished by the use of a non-invasive sensor that passes light through a portion of a patient's blood perfused tissue and photo-electrically senses the absorption and scattering of light in such tissue.

[0018] The light passed through the tissue is typically selected to be of two or more wavelengths that are absorbed by the blood in an amount related to the amount of blood constituent present in the blood. The amount of transmitted light that passes through the tissue varies in accordance with the changing amount of blood constituent in the tissue and the related light absorption.

[0019] To estimate arterial blood oxygen saturation of a patient, conventional two-wavelength pulse oximeters emit light from two light emitting diodes (LEDs) into a pulsatile tissue bed and collect the transmitted light with a photo detector positioned on an opposite surface (i.e., for transmission pulse oximetry) or an adjacent surface (i.e., for reflectance pulse oximetry). The LEDs and photodetector are typically housed in a reusable or disposable oximeter sensor that couples to a pulse oximeter electronics and display unit. One of the two LEDs' primary wavelength is selected at a point in the electromagnetic spectrum where the absorption of oxyhemoglobin (HbO₂) differs from the absorption of reduced hemoglobin (Hb). The second of the two LEDs' wavelength is selected at a different point in the spectrum where the absorption of Hb and HbO₂ differs from those at the first wavelength. Commercial pulse oximeters typically utilize one wavelength in the near red part of the visible spectrum near 660 nanometers (nm) and one in the near infrared (IR) part of the spectrum in the range of 880-940 nm.

[0020] **FIG. 1** is a block diagram of one embodiment of a pulse oximeter that may be configured to implement the embodiments of the present invention. The filter embodiments of the present invention can be a data processing

algorithm that is executed by the microprocessor 122, described below. Light from light source 110 passes into patient tissue 112, and is scattered and detected by photodetector 114. A sensor 100 containing the light source and photodetector may also contain an encoder 116 which provides signals indicative of the wavelength of light source 110 to allow the oximeter to select appropriate calibration coefficients for calculating oxygen saturation. Encoder 116 may, for instance, be a resistor.

[0021] Sensor 100 is connected to a pulse oximeter 120. The oximeter includes a microprocessor 122 connected to an internal bus 124. Also connected to the bus is a RAM memory 126 and a display 128. A time processing unit (TPU) 130 provides timing control signals to light drive circuitry 132 which controls when light source 110 is illuminated, and if multiple light sources are used, the multiplexed timing for the different light sources. TPU 130 also controls the gating-in of signals from photodetector 114 through an amplifier 133 and a switching circuit 134. These signals are sampled at the proper time, depending upon which of multiple light sources is illuminated, if multiple light sources are used. The received signal is passed through an amplifier 136, a low pass filter 138, and an analog-to-digital converter 140. The digital data is then stored in a queued serial module (QSM) 142, for later downloading to RAM 126 as QSM 142 fills up. In one embodiment, there may be multiple parallel paths of separate amplifier filter and A/D converters for multiple light wavelengths or spectrums received.

[0022] Based on the value of the received signals corresponding to the light received by photodetector 114, microprocessor 122 will calculate the oxygen saturation using various algorithms. These algorithms require coefficients, which may be empirically determined, corresponding to, for example, the wavelengths of light used. These are stored in a ROM 146. The particular set of coefficients chosen for any pair of wavelength spectrums is determined by the value indicated by encoder 116 corresponding to a particular light source in a particular sensor 100. In one embodiment, multiple resistor values may be assigned to select different sets of coefficients. In another embodiment, the same resistors are used to select from among the coefficients appropriate for an infrared source paired with either a near red source or far red source. The selection between whether the near red or far red set will be chosen can be selected with a control input from control inputs 154. Control inputs 154 may be, for instance, a switch on the pulse oximeter, a keyboard, or a port providing instructions from a remote host computer. Furthermore any number of methods or algorithms may be used to determine a patient's pulse rate, oxygen saturation or any other desired physiological parameter. The pulse oximeter shown in FIG. 1 is shown for exemplary purposes and is not meant to limit the embodiments of the present invention. For example, the sensor can be replaced by other appropriate sensors for use at other tissue locations including the ear, foot, forehead and nose of adult, infant, neonatal and perinatal patients.

[0023] Oxygen saturation can be estimated using various techniques. In one common technique, the photo-current generated by the photo-detector is conditioned and processed to determine the modulation ratio of the red to infrared signals. This modulation ratio has been observed to correlate well to arterial oxygen saturation. The pulse

oximeters and sensors are empirically calibrated by measuring the modulation ratio over a range of in vivo measured arterial oxygen saturations (SaO₂) on a set of patients, healthy volunteers, or animals. The observed correlation is used in an inverse manner to estimate blood oxygen saturation (SpO₂) based on the measured value of modulation ratios of a patient. The estimation of oxygen saturation using modulation ratios or ratio of ratios is described in U.S. Pat. No. 5,853,364, entitled "METHOD AND APPARATUS FOR ESTIMATING PHYSIOLOGICAL PARAMETERS USING MODEL-BASED ADAPTIVE FILTERING", issued Dec. 29, 1998, and U.S. Pat. No. 4,911,167, entitled "METHOD AND APPARATUS FOR DETECTING OPTICAL PULSES", issued Mar. 27, 1990. The relationship between oxygen saturation and modulation ratio is further described in U.S. Pat. No. 5,645,059, entitled "MEDICAL SENSOR WITH MODULATED ENCODING SCHEME," issued Jul. 8, 1997. An electronic processor for calculating in vivo blood oxygenation levels using pulsed light is described in U.S. Pat. No. 5,348,004, entitled "ELECTRONIC PROCESSOR FOR PULSE OXIMETER," issued Sep. 20, 1994, and a display monitor for a pulse oximeter is described in U.S. Pat. No. 4,653,498, entitled "PULSE OXIMETER MONITOR," issued Mar. 31, 1987. All five patents are assigned to the assignee of the present invention and incorporated herein by reference.

[0024] The brief description of pulse oximeters, and associated electronic circuitry and algorithms described above serve as a contextual fabric for describing the method for estimating signal quality and the signal quality metrics design according to embodiments of the present invention, which are described below.

[0025] Signal Quality

[0026] While the methodologies described in the patents cited above are used to provide estimates of blood oxygen saturation and pulse rate, many intermediate signals are first obtained by the oximetry sensor which when finally processed through these circuits and algorithms conclude in determining these final estimates of blood oxygen saturation and pulse rate. A set of these intermediate signals is used for signal quality indicators. The signal quality indicators are then combined and processed to estimate a signal quality metric. The value of the signal quality metric is compared to a threshold and based on this comparison various decisions are made by the medical device. One decision is directed towards deciding whether or not to display the measured physiologic parameter. Another decision is directed towards providing feedback to guide the clinician to adjust the location of the sensor, when the signal quality metric is below a threshold.

[0027] A. Signal Quality Indicators

[0028] A signal quality indicator is a measured parameter that is capable of estimating the reliability and accuracy of a signal. For example, when measuring blood oxygen saturation using a pulse oximeter, a signal quality indicator is able to indirectly assess whether an estimate of a value of blood oxygen saturation is an accurate one. This determination of accuracy is made possible by a thorough and detailed study of volumes of measured values and various indicators to determine which indicators are indicative of signal quality and what, if any, is the correlation between the indicator and the accuracy of the estimated value. While a

particular indicator may be highly correlated to the accuracy of a measured value, it is determined that a combination of several indicators correlates better to the accuracy of measured value over a wider range of clinical conditions. A few of these indicators are referred to as the “OVERLAP,” “MIN-MAX-MIN,” “PATH LENGTH” and “IR nAv” indicators. These, as well as other indicators and their utilities in determining the signal’s quality and hence the accuracy of oxygen saturation estimates are each described below.

[0029] The “OVERLAP” indicator is a measure of the similarity of the pulse forms obtained from different wavelengths, such as for example, the infrared and red pulse forms. While many algorithms may be used to compute “OVERLAP,” one equation that may be used to compute it is as follows:

$$R = \frac{\ln(Red_{max} / Red_{min})}{(IR_{max} / IR_{min})}$$

$$Overlap = \frac{\sum \min(IR_t - IR_{min}, (Red_t - Red_{min}) / R)}{\sum IR_t - IR_{min}}$$

where IR_t and Red_t have been AC—coupled and normalized by their respective DC levels and the summations cover a timespan ranging from one to several seconds. This indicator is useful in determining the accuracy of the measured oxygen saturation value because it provides for an indirect method of sensing the extent to which the two wavelengths which are used by a sensor are probing the same tissue volume. It is known that errors in oxygen saturation measurements using pulse oximeters occur when the two light sources providing light at two wavelengths probe two different tissue locations. Thus when the two or more different pulse forms do not look the same, it is likely that photons are being modulated by different volumes of tissue, which is known to cause inaccurate measurements. On the other hand, when the two or more pulse forms (e.g., infrared and red) look the same, or “OVERLAP,” then this indicates that it is likely that the same tissue volume is being probed by the two different wavelengths of light, thus avoiding a known source of error.

[0030] The “MIN-MAX-MIN” indicator provides for a measure of the arterial pulse shape. The arterial pulse referred to herein is caused by a cardiac cycle commonly referred to a heartbeat. During a typical cardiac cycle, blood pressure rises from a minimum value (MIN) at diastole to a maximum (MAX) at systole. The “MIN-MAX-MIN” indicator is a ratio represented by a fraction having the time it takes the pulse to go from a MAX to a MIN as the numerator and having the time it takes the pulse to go from a MIN to a MAX as the denominator. This indicator provides an indication of the ratio of fall to rise times of arterial pulse. A fundamental fact of human physiology is that in a typical arterial pulse, it takes a shorter time to go from the diastole to systole (MIN to MAX) than it does to go from systole to diastole (MAX to MIN). Recognizing this fundamental physiological aspect, then if the “MIN-MAX-MIN” indicator shows that for a pulse, the rise time is bigger than the fall time, then this indicates that the sensor’s light is being modulated by other than an arterial pulse. The inventors have identified that when a pulse’s rise time is bigger than its fall time, the light is not modulated by pulsation of evenly

distributed arterial blood, but it is most likely that the observed pulse-like phenomenon is due to throbbing of underlying large blood vessels or physical movement of the sensor. It is known that either of these mechanisms may cause large errors in the calibration of the resulting oxygen saturation estimate. Therefore, by analyzing the shape of the arterial pulse, the “MIN-MAX-MIN” indicator determines whether the light modulation is due to a pulsation, or evenly distributed arterial blood, or other phenomenon such as motion.

[0031] The “PATH LENGTH” indicator is also indicative of the pulse shape. This indicator provides for a measure of the frequency content of the pulse waveform relative to the pulse rate. While many algorithms may be used to compute “PATH LENGTH,” one equation that may be used to compute it is as follows:

$$PathLength = \frac{\sum_{i=0}^{i=Samples_in_Pulse-1} |IR_{t-i} - IR_{t-i-1}|}{Pulse_Max - Pulse_Min}$$

[0032] High values of this metric indicate that a high proportion of the energy in the pulse is at frequencies higher than the pulse rate. High frequency components in the arterial pulse shape are an indication that light is being modulated by other than arterial pulsations. These high frequency components are also most likely to be caused by movement of the sensor. As described above, it is known that physical movement is a source of error when estimating blood oxygen saturation in pulse oximeters. Therefore, the “PATH LENGTH” indicator, is also a motion indicator, which is used to infer that signals that have high frequency components often lead to inaccurate estimates of pulse rate and/or blood oxygen saturation.

[0033] The “IR nAv” indicator provides for an infrared (IR) measure of the optical density of the tissue. This indicator represents a light level which has been normalized for the LED’s brightness. In other words, the “IR nAv” indicator is a low light level measure. It is recognized that the cause of a low light level measure is sensor misplacement, as in when a sensor is placed over hair or other medium interfering with the light path between the sensor and the probed tissue volume. Therefore, the “IR nAv” indicator is used to infer that the measured value is potentially inaccurate because of sensor misplacement.

[0034] In addition to the indicators described above, many other indicators also provide for estimates of signal quality and hence a measure of the accuracy of the physiological measurements. These include indicators that qualify: pulse shape; pulse amplitude; modulation ratios of the red to infrared signals, known as ratio of ratios and pulse period. Moreover, other indicators that trend the consistency of pulse shapes relative to each of these additional indicators are also viable as measures of signal quality.

[0035] The signal quality indicators described above, may be derived from any wavelength used by an oximeter. Further, these indicators may be derived after a variety of signal processing operations including filtering of the signal, such as low pass, high pass and comb filtering. Furthermore,

although the indicators described above are based on time-domain analyses, similar indicators are derivable in the frequency domain as is apparent to those knowledgeable in signal processing.

[0036] B. Algorithms for Determining an Overall Signal Quality (SQ) Metric

[0037] As stated above, the signal quality indicators are processed and combined to provide an overall value for a lumped signal quality (SQ) metric. Many algorithms may be used to arrive at the lumped SQ value. An example of such an algorithm is shown below, which may be described as a combination of the "OVERLAP," "MIN-MAX-MIN" and "IR nAv" indicators.

$SQ = SQ1 * (SQ2/100) * (SQ3/100)$, where

[0038] $SQ1 = 100 - 5 * (96 - \text{OVERLAP})$, clipped to between 0 and 100

[0039] $SQ2 = 100 - (\text{MIN-MAX-MIN} - 16000) / 70$, clipped to between 0 and 100

[0040] $SQ3 = 100 - 5 * (25 - \text{IR nAv})$, clipped to between 50 and 100,

[0041] For example, for this particular algorithm, SQ is updated on each qualified pulse. Alternate algorithms update the calculation of SQ at other periodic rates, ranging from once every 5 seconds to once every one tenth of a second. The particular choice of algorithm which is used to compute an SQ, is very dependent on the choice of indicators and the target value for the lumped SQ parameter. As shown here, only three of the indicators are used, namely, "OVERLAP," "MIN-MAX-MIN" and "IR nAv." Using this particular algorithm, the SQ value is configured to have a range between 0 and 100. The algorithm shown above is for exemplary purposes only, since many other algorithms can be derived which would also combine various indicators to arrive at an overall signal quality metric. The advantage of this particular algorithm is that it is a relatively simple one, only using three signal quality indicators. Further, this particular algorithm processes the signal quality indicators by scaling and clipping the indicators to values to derive a signal quality metric which has a very ordinary range of between 0 and 100. Most, if not all practitioners in the technical and scientific communities can appreciate that a value of 100 represents a high quality value and that a value of 0 represents a low quality value. Depending on the choice of indicators and the desired range of values for the final SQ metric, many alternate algorithms can be contemplated, each having various different advantages and disadvantages as compared to the exemplary algorithm described above.

[0042] C. Processing SQ

[0043] Having determined a signal quality (SQ) value by combining various signal quality indicators, the next task in determining whether a measured value is accurate and worthy of being displayed on a pulse oximeter's monitor is to compare the SQ value to a threshold. As described above, the SQ value is calculated periodically, and therefore it can also change periodically. This change in signal quality can occur due to both changes in physiological conditions of the patient as well as non-physiologically induced changes. Non-physiological changes in signal quality can be caused by such factors as motion of the sensor, changes in the sensor to tissue positioning and optical interference between

the sensor and the tissue location such as those caused by hair being placed in between the sensor and the tissue location. These non-physiological-based changes occur to a higher extent in perinatal pulse oximeters, where the sensor-to-fetus positioning can change rapidly as the fetus moves in the womb during the course of labor and delivery.

[0044] Algorithms that make the decision regarding whether or not to display a measured value of a physiological parameter on a display monitor of a pulse oximeter, must account for the potential rapid changes in signal quality. Thus, a small-magnitude, short-time change in signal quality should not be reacted to quickly, thus preventing annoying and spurious responses. On the other hand, small magnitude changes in signal quality should not cause a delayed response that could result in the display of inaccurate measurements. Therefore, to avoid erratic changes in the response of the diagnostic device, algorithms that decide whether or not a measured value is of a high enough quality, and algorithms that decide whether or not the value should be displayed preferably should act on a processed form of the SQ value.

[0045] The concept of tempering a system's response to an input is known in the automatic controls arena. This concept is related to various operations, including the proportional (P), integral (I) and derivative (D) control operations, with each operation having different attributes. A control operation using a combination of proportional, integral and derivative operations in response to an input is referred to as a PID control system. The embodiments of the present invention enhance the algorithms which are used to make decisions regarding whether or not to display a measured value on a display monitor by incorporating PID operations with these algorithms. Each of the proportional, integral and derivative operations as applied to the SQ-based algorithms is described below.

[0046] With proportional control, a change in response is made which is proportional to the change in input. For example, with proportional control, if the decision to display a measured value depends on the SQ being equal to or above a threshold value, the instant the SQ value exceeds the threshold, the measured value is displayed, and the very instant the SQ value drops below the threshold, the measured value is removed from the display. While a proportional control operation may be instantly responsive, it will also respond erratically to erratic changes in input. This potential of an erratic response is not ideal because short-lived excursions in SQ will cause short-lived responses which are, as described above, not desired.

[0047] With integral control, the input change is integrated over time and a change in response occurs when an integrated threshold value is met. Consider, for example if the integral threshold for removing a measured value from a display is set to a value of 10 SQ-seconds, beyond a threshold of SQ of 80. Under this scenario, a drop in SQ from 81 to 79 would cause the displayed value to be removed in 5 seconds, since the deviation of 2 SQ (81-79=2 SQ) times 5 seconds would equal 10 SQ-seconds. A bigger drop in SQ beyond the threshold value would remove the displayed value sooner, and conversely a smaller drop in the SQ beyond the threshold would remove the displayed value later. Thus, an integral control operation delays the decision by waiting for an integrated threshold to be met. In this

manner, an integral-based control operation is able to ride out short lived excursions and result in an overall smoother display operation for a pulse oximeter device.

[0048] Lastly, a derivative control system responds to the rate of change of the input parameter as opposed to the parameter itself, as in proportional control, or an integrated change in the parameter, as in integral control. A derivative-based system anticipates the change in the input parameter and is thus able to foresee when an increasing SQ value is nearing the SQ threshold. In other words, derivative control will cause a transition to display a measured value on the display monitor faster of SQ has improved over the last few sensing periods.

[0049] Thus, the diagnostic device's decision making directed to determining whether a measured value has a high enough SQ to be worthy of being displayed on an oximeter's monitor is based on comparing a PID processed SQ to a threshold value. The PID processed SQ value is achieved by operating on the SQ value using a combination of proportional, derivative and integral operations. For example, the decision to post may be made when the combination of the proportional, integral and derivative processed SQ value exceeds a threshold, as is shown below (i.e., display the measured value if P+I+D is greater than a threshold):

$$P+I+D > \text{Threshold, where}$$

$$P = P0 * (SQ - 75) / 25, \text{ where}$$

[0050] P0 is a proportional component scalar;

[0051] SQ is signal quality

$$I = \int (SQ - 50) dt, \text{ where}$$

[0052] the integral is updated each second; and

$$D = D0 * (SQ_1 - SQ_0) / 14, \text{ where}$$

[0053] SQ₁ is the current signal quality

[0054] SQ₀ is the signal quality one second before

[0055] D0 is the derivative component scalar

[0056] Thus, various algorithms are used to compute a signal quality metric for comparison to a threshold. Further, before comparing the calculated SQ value, an alternate embodiment processes the SQ value using PID operations. Once the PID processed or non-processed SQ value is compared to a threshold, various decisions are made by the medical device. As stated above, one decision is directed towards deciding whether or not to display the measured physiologic parameter. Another decision is directed towards providing feedback to guide the clinician to adjust the location of the sensor, when the signal quality metric is below a threshold.

[0057] D. Decision Algorithm

[0058] FIG. 2 is a flow chart 200 showing an embodiment of the above described decision making algorithm in accordance with the present invention. First a plurality of signal quality indicators are measured (step 210). Next, the signal quality indicators are processed and combined to calculate an SQ metric (step 212). As described above, the SQ value changes periodically, and may also change rapidly. To smooth out potential changes in the time-varying SQ value, it is PID processed (step 214). Next, the value of the PID processed SQ metric is compared to a threshold (step 216). If the value is at least equal to the threshold, the measured

physiological value is sent to be displayed by the device's monitor (step 218). For example, when the medical device is a pulse oximeter with a display monitor and the device is measuring oxygen saturation, once the PID processed SQ value exceeds the threshold, indicating that the measured value is reliable and accurate, the device makes the decision to display the oxygen saturation value on its display monitor. The measured value (i.e., oxygen saturation) remains displayed until the PID processed SQ value drops below a threshold.

[0059] On the other hand, if the PID processed value is below the threshold (step 216), the measured physiologic value is not displayed. Next, the PID processed SQ value is compared to another threshold (step 220). The threshold at step 220 may be equal to the threshold at step 216. Alternately the threshold at step 220 may be set to a different value if the PID processed SQ value exceeds the second threshold value, the decision loop is ended (step 224) and the process begins all over again (step 210). On the other hand, if the PID processed SQ value is lower than the second threshold, a diagnostic message is displayed (step 226) on the medical devices display monitor to appropriately guide the clinician. For example, a text message such as "ADJUST SENSOR" is posted on the display monitor to guide the clinician to adjust the sensor's positioning. Once the "ADJUST SENSOR" text message is displayed, it remains displayed until the sensor's location is adjusted. Alternately, the diagnostic message may be an audible or visual alarm indicating that the sensor location must be adjusted.

[0060] While the PID processing of the SQ value provides the advantages described above, it may lead to a delayed response, for example a PID processed SQ value with a large integral component- due to the required integration times. To avoid a potential delayed response, the PID algorithm is adjusted to reduce the significance of the integral component. Alternately, the algorithms are configured to base the decision making on a non-PID processed SQ signal.

[0061] Experiments conducted by the inventors show that pulse oximeter devices configured to use embodiments of the present invention described above, provide an increase in the overall posting time of the measures physiological values. Further, the improvements related to implementation of the embodiments of the present invention, provide for improvements in the accuracy of the displayed saturation values. Additionally, the "ADJUST SENSOR" feature leads to improved sensor placement. And lastly, with improved sensor placement, posting of the displayed signal begins sooner.

[0062] As will be understood by those of skill in the art, the present invention which is related to estimating the reliability and accuracy of a monitored value, and diagnostics algorithms based on that estimate, may be embodied in other specific forms without departing from the essential characteristics thereof. For example, variables other than oxygen saturation such as pulse rate, blood pressure, temperature, or any other physiological variable could be continuously or periodically tracked. Further, while the present embodiments have been described in the time-domain, frequency-based methods are equally relevant to the embodiments of the present invention. Accordingly, the foregoing

disclosure is intended to be illustrative, but not limiting, of the scope of the invention which is set forth in the following claims.

1. A method for evaluating a signal, comprising:
 - obtaining a signal quality metric based on a measured physiological parameter;
 - comparing the signal quality metric to a first threshold;
 - comparing the signal quality metric to second threshold if the processed signal quality metric is less than the first threshold; and
 - providing an indication of poor signal quality if the signal quality metric is less than the first threshold and the second threshold.
2. The method, as set forth by claim 1, comprising obtaining the signal quality metric from one or more signal quality indicators acquired with the measured physiological parameter.
3. The method, as set forth by claim 2, wherein the signal quality indicators comprise a similarity overlap between a first and a second electromagnetic signal, wherein the first and second electromagnetic signals differ in frequency.
4. The method, as set forth by claim 2, wherein the signal quality indicators comprise a measure based on a shape of an arterial pulse.
5. The method, as set forth by claim 2, wherein the signal quality indicators comprise a frequency content of a pulse waveform relative to pulse rate.
6. The method, as set forth by claim 1, comprising processing the signal quality metric using one or more of proportional (P), integral (I), or derivative (D) control operations.
7. The method, as set forth by claim 1, wherein the measured physiological parameter comprises pulse oximetry measurements.
8. The method, as set forth by claim 1, comprising remeasuring the physiological parameter if the signal quality metric is less than the first threshold and greater than the second threshold.
9. The method, as set forth by claim 1, wherein the indication comprises a text message indicating the poor signal quality.
10. The method, as set forth by claim 1, wherein the indication comprises an alarm indicating the poor signal quality.
11. A method for evaluating a physiological measurement, comprising the acts of:
 - obtaining a signal quality metric based on a physiological parameter acquired by a physiological sensor; and
 - directing an operator to reposition the physiological sensor if the signal quality metric is below a threshold value.
12. The method, as set forth by claim 11, wherein the sensor is a pulse oximetry sensor.
13. The method, as set forth by claim 11, comprising comparing the signal quality metric to the threshold value after the signal quality metric is processed by one or more of proportional (P), integral (I), or derivative (D) control operations.
14. The method, as set forth by claim 11, wherein directing the operator comprises providing one or more of a visual, audible, or temporal indication of signal quality.

15. The method, as set forth by claim 11, wherein the signal quality metric corresponds to dislocations of the sensor.

16. A tangible machine readable medium configured to evaluate a signal, comprising:

- code configured to obtain a signal quality metric based on a measured physiological parameter;
- code configured to compare the signal quality metric to a first threshold;
- code configured to compare the signal quality metric to a second threshold if the processed signal quality metric is less than the first threshold; and
- code configured to provide an indication of poor signal quality if the signal quality metric is less than the first threshold and the second threshold.

17. The tangible machine readable medium, as set forth by claim 11 comprising code configured to obtain the signal quality metric from one or more signal quality indicators acquired with the measured physiological parameter.

18. The tangible machine readable medium, as set forth by claim 17, comprising code configured to obtaining a measure based on the shape of an arterial pulse as one of the signal quality indicators.

19. The tangible machine readable medium, as set forth by claim 17, comprising code configured to obtain a frequency content of a pulse waveform relative to pulse rate as one of the signal quality indicators.

20. The tangible machine readable medium, as set forth by claim 17, comprising code configured to process the signal quality metric using one or more of proportional (P), integral (I), or derivative (D) control operations.

21. A tangible machine readable medium configured to evaluate a physiological measurement, comprising:

- code configured to obtain a signal quality metric based on a physiological parameter acquired by a physiological sensor; and
- code configured to direct an operator to reposition the physiological sensor if the signal quality metric is below a threshold value.

22. The tangible machine readable medium, as set forth by claim 17, comprising code configured to compare the signal quality metric to the threshold value after the signal quality metric is processed by one or more of proportional (P), integral (I), or derivative (D) control operations.

23. The tangible machine readable medium, as set forth by claim 17, comprising code configured to provide one or more of a visual, audible, or temporal indication of signal quality.

24. A system for evaluating a signal comprising:

- a sensor adapted to acquire a physiological parameter;
- a signal processor adapted to obtain a signal quality metric based on the physiological parameter, to compare the signal quality metric to a first threshold, and to compare the signal quality metric to a second threshold if the processed signal quality metric is less than the first threshold; and
- a device adapted to provide an indication of poor signal quality if the signal quality metric is less than the first threshold and the second threshold.

25. The system, as set forth by claim 24, wherein the sensor is a pulse oximetry sensor.

26. The system, as set forth by claim 24, wherein the signal processor is adapted to execute one or more of proportional (P), integral (I), or derivative (D) control operations.

27. The system, as set forth by claim 24, wherein the device is a monitor.

28. The system, as set forth by claim 24, wherein the device is an audible device.

29. A system for evaluating a physiological measurement, comprising:

a sensor adapted to acquire a physiological parameter;

a signal processor adapted to obtain a signal quality metric based on a physiological parameter and to compare the signal quality metric to a threshold value; and

an interface device configured to direct an operator to reposition the sensor if the signal quality metric is below the threshold value.

30. The system, as set forth by claim 29, wherein the physiological parameter is derived from pulse oximetry.

31. The system, as set forth by claim 29, wherein the processor is adapted to obtain the signal quality metric from signal quality indicators.

32. The system, as set forth by claim 29, wherein the interface device comprises at least one of a display or a speaker.

33. A method for evaluating a signal comprising:

obtaining signal quality indicators associated with the measurement of a physiological parameter; and

obtaining a signal quality metric associated with the signal quality indicators by non-neural network processes.

* * * * *

专利名称(译)	信号质量度量设计用于生理监测器的合格数据		
公开(公告)号	US20060135860A1	公开(公告)日	2006-06-22
申请号	US11/293714	申请日	2005-12-02
[标]申请(专利权)人(译)	BAKER JR CLARK - [R RICHARDS EDWARD中号		
申请(专利权)人(译)	BAKER CLARK - [R JR RICHARDS EDWARD中号		
当前申请(专利权)人(译)	COVIDIEN LP		
[标]发明人	BAKER CLARK R JR RICHARDS EDWARD M		
发明人	BAKER, CLARK R. JR. RICHARDS, EDWARD M.		
IPC分类号	A61B5/00 A61B5/024		
CPC分类号	A61B5/024 A61B5/145 A61B5/1455 A61B5/7239		
其他公开文献	US8095192		
外部链接	Espacenet USPTO		

摘要(译)

一种用于确定用于测量生理参数的信号质量的方法和设备。本发明的一个实施例涉及脉搏血氧计，其中测量的生理参数包括患者的脉搏率和血氧饱和度。通过组合多个信号质量指示符来计算指示所测量的生理参数的准确性和可靠性的信号质量，每个信号质量指示符是测量信号的质量的指示符。将信号质量度量的值与阈值进行比较，并且基于该比较，由医疗设备做出各种决定。一个决定是针对决定是否显示测量的生理参数，以确保仅显示准确的测量值。另一个决定是针对提供反馈以指导临床医生将传感器的位置调整到更合适的组织位置。

