



(19) **United States**

(12) **Patent Application Publication** (10) **Pub. No.: US 2004/0236189 A1**

**Hawthorne et al.**

(43) **Pub. Date: Nov. 25, 2004**

(54) **BIO-INFORMATION SENSOR MONITORING SYSTEM AND METHOD**

**Publication Classification**

(76) Inventors: **Jeffrey Scott Hawthorne**, Bennett, CO (US); **Michael Leonard Iiams**, Littleton, CO (US); **Glenn Charles Tubb**, Englewood, CO (US); **Richard A. Stoll**, Morrison, CO (US); **Gary Alan Shoffner**, Westminster, CO (US)

(51) **Int. Cl.<sup>7</sup>** ..... **A61B 5/00**  
(52) **U.S. Cl.** ..... **600/300**; 128/904; 600/309; 600/549; 600/529; 600/481

(57) **ABSTRACT**

A bio-information monitoring system passively monitors a patient with a remote portable bio-information unit that takes various bio-information measurements at selected time intervals as well as at random times without patient intervention. The measurements are converted to digital signals which are transmitted from the bio-information unit to a modem when the bio-information unit is in proximity to the modem. The signals are stored in the modem and uploaded to a central monitoring network. Automatic alerts may be sent from the central monitoring network to a treatment provider. The treatment provider may also access the information through secured dedicated websites via the Internet.

Correspondence Address:  
**Stanley J. Gradisar**  
**Gibson, Dunn & Crutcher LLP**  
**Suite 4100**  
**1801 California St.**  
**Denver, CO 80202 (US)**

(21) Appl. No.: **10/441,960**

(22) Filed: **May 19, 2003**

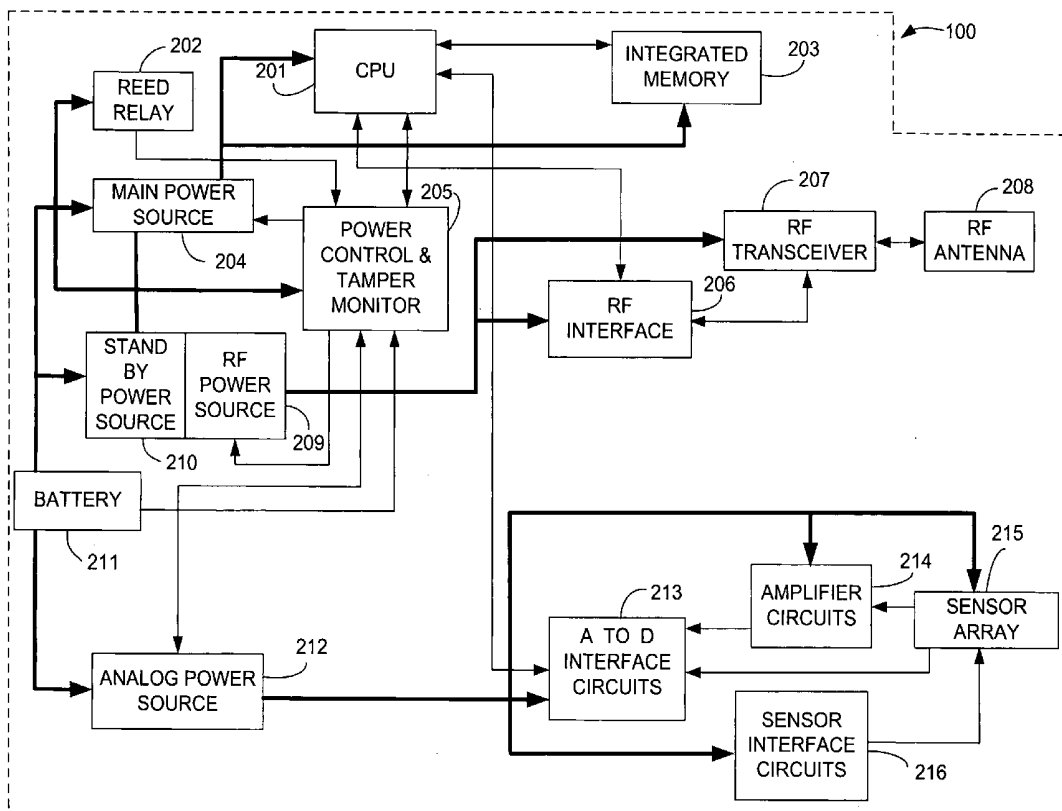

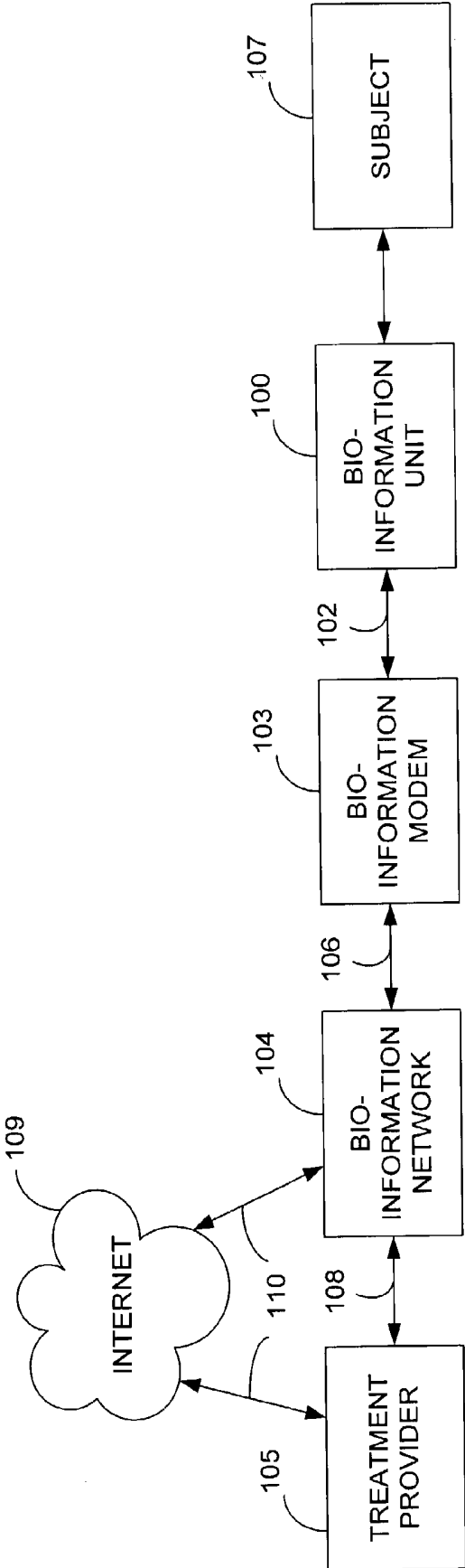
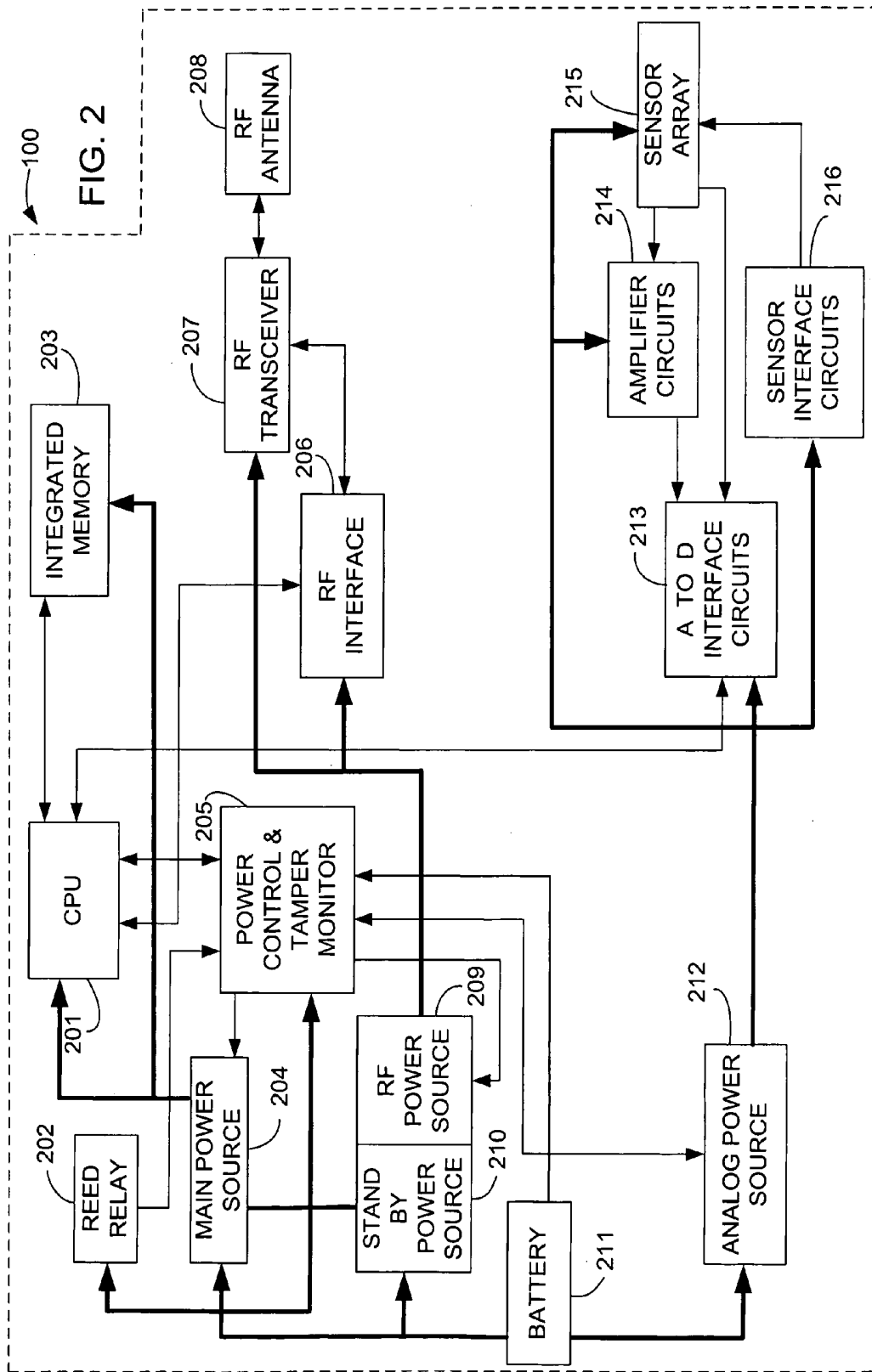

FIG. 1



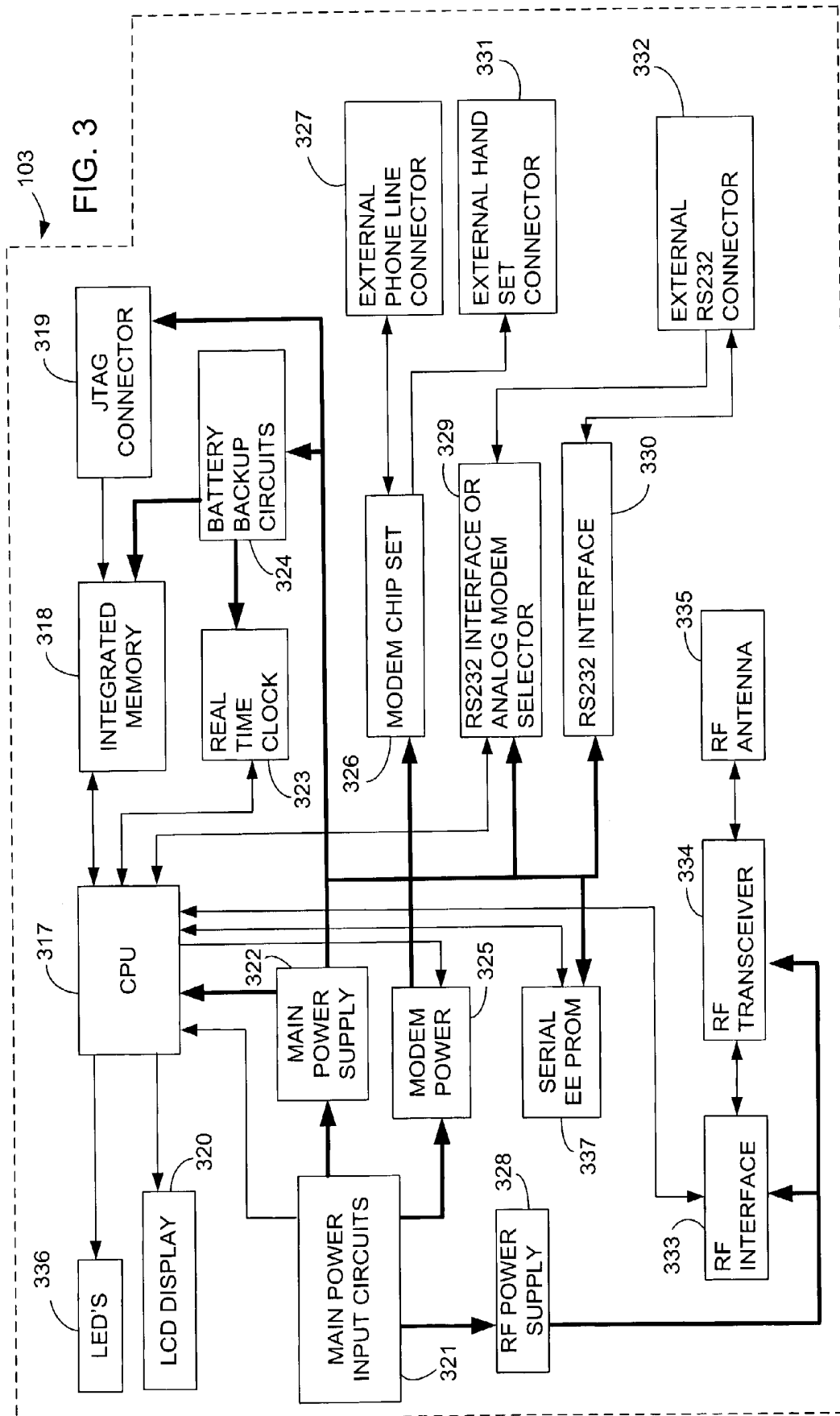

FIG. 4A

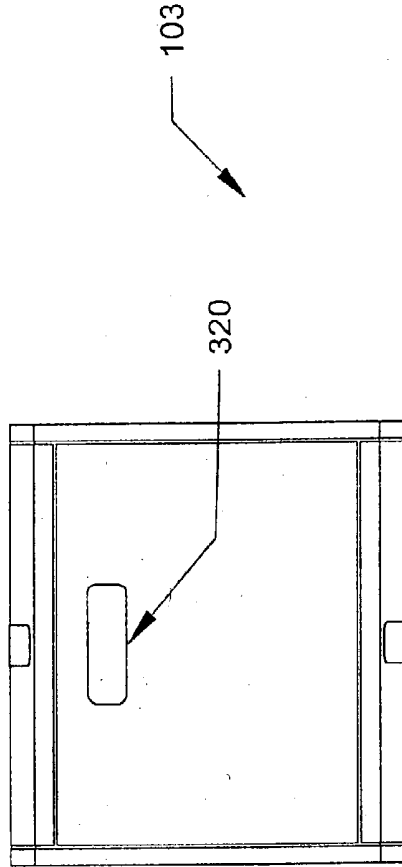

FIG. 4C

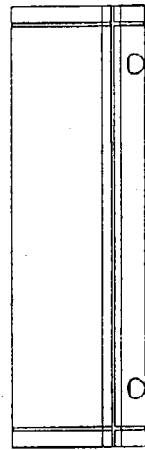

FIG. 4D

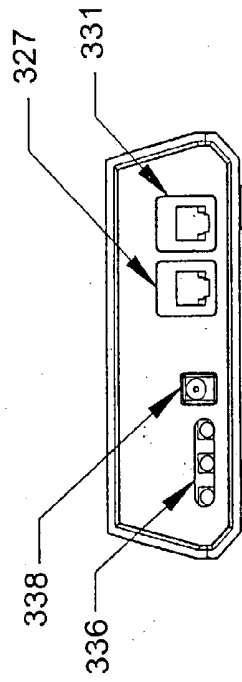
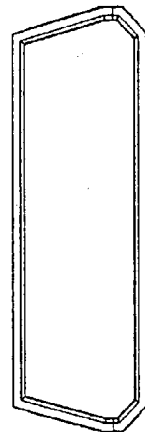

FIG. 4B



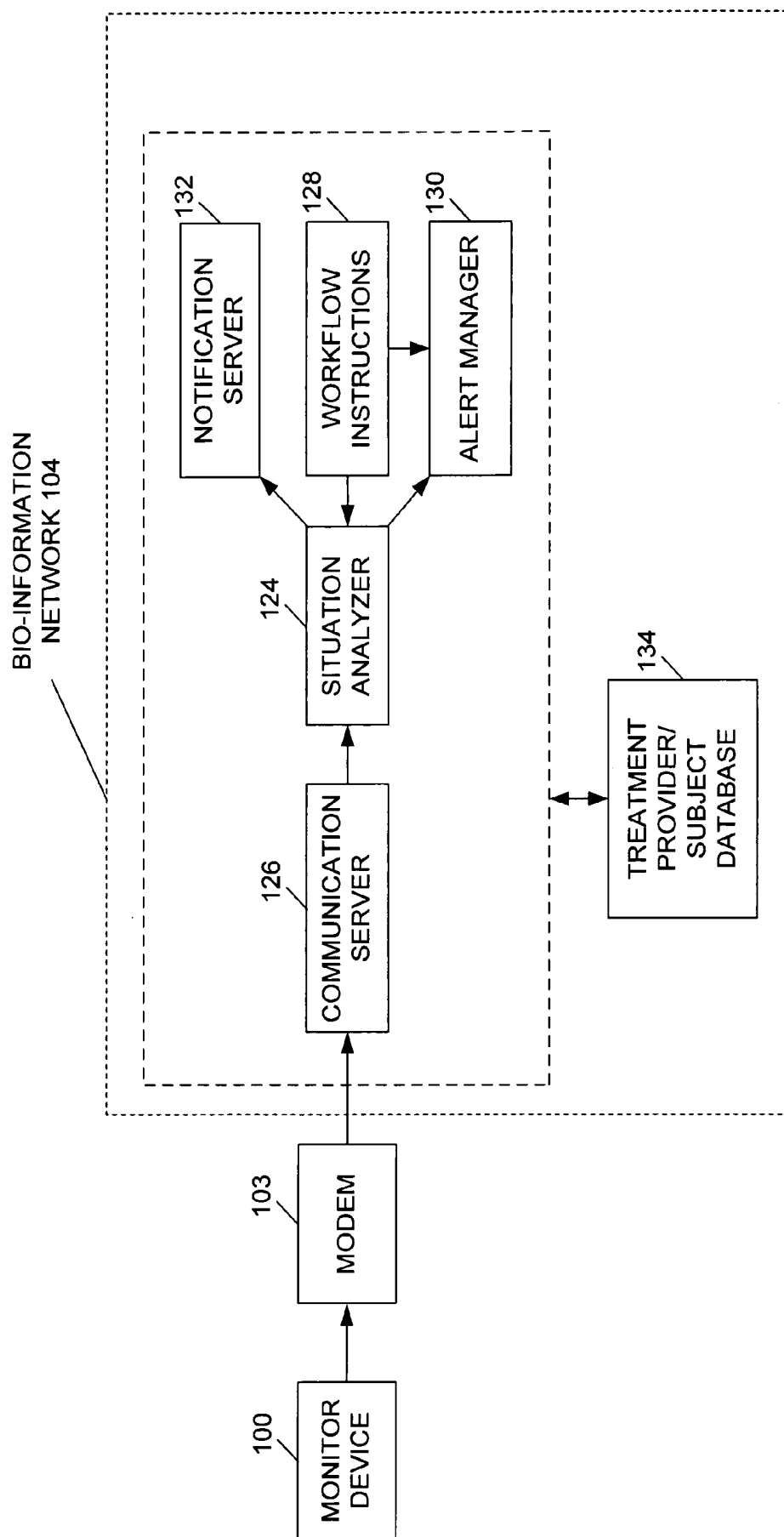

FIG. 5

## BIO-INFORMATION SENSOR MONITORING SYSTEM AND METHOD

### CROSS REFERENCE TO RELATED APPLICATION

[0001] This application is related to a co-pending patent application Ser. No. \_\_\_\_\_ by Hawthorne et al. titled "METHOD AND APPARATUS FOR REMOTE BLOOD ALCOHOL MONITORING" and filed on the same day herewith, which is owned by the same assignee of this invention.

### FIELD OF THE INVENTION

[0002] This invention relates to medical monitoring systems, and more particularly, relates to an improved passive method and system for monitoring bio-information of a subject.

### BACKGROUND OF THE INVENTION

[0003] In-home monitoring for the purpose of health management of chronic disease patients typically requires the patients to attach monitors of various kinds to their bodies, actuate the monitors to take various bio-information readings, and then hook up the monitor to a communication device, and then send the readings taken to a monitoring station or health care provider. Various types of monitors may be used to gather bio-information data regarding the patient. Such monitors may take the patient's blood pressure, temperature, pulse, SpO<sub>2</sub>, CO, ICG, ECG, respiration, blood glucose, and the like. Such information can provide valuable feedback on the health status of the patient to the health care provider. Current technology allows for patients to take regular measurements at home that get collected and transferred, typically via a standard telephone line, to a data collection system, or directly to a health care provider. This methodology is a significant improvement over techniques that require patients to keep written logs of measurements taken themselves. Such written logs are subject to errors or missing data, and are usually only reviewed by a healthcare provider during routine checkups. In addition, some patients do not want to cooperate and take the readings that are needed, posing an additional problem to the healthcare provider.

[0004] There is a need for a remote bio-information monitoring system which can be passively used by the patient that can take the various measurements at selected time intervals as well as at random times without patient intervention. There is also a need to be able to download the bio-information measurements to a monitoring station or healthcare provider without requiring any actions on the part of the patient being monitored, eliminating the need for the patient to personally record the measurements, or connect the monitoring device to a telephone line to download and transmit the data. The present invention meets these and other needs in the art.

### BRIEF DESCRIPTION OF THE DRAWINGS

[0005] FIG. 1 shows a block diagram of the bio-information sensor monitoring system of the present invention.

[0006] FIG. 2 shows a block diagram of the Bio-Information Unit 100 of FIG. 1.

[0007] FIG. 3 shows a block diagram of an embodiment of Bio-Information Modem 103.

[0008] FIGS. 4A-4D show a top view and three elevation views of the modem in an embodiment of the present invention.

[0009] FIG. 5 shows a block diagram of the monitor network in an embodiment of the present invention.

### DETAILED DESCRIPTION OF THE INVENTION

[0010] FIG. 1 shows a block diagram of the bio-information sensor monitoring system of the present invention. The system and method is designed to collect, store and forward the information measured, sensed, or otherwise captured by various bio-sensors to a central web-hosted database, where treatment providers can gain access to the data collected by the bio-sensors. The system and method provides a portable means for the bio-information to be collected. The system and method can be used to remotely monitor any biological data including, but not limited to, blood oxygen, blood carbon dioxide, insulin levels, heart rate, temperature, respiration, and any other biological data based on the specific bio-sensor(s) being used in the bio-information unit. The system allows for the one or more portable bio-sensors to be worn, attached, or otherwise utilized by a subject for an extended period of time in an untethered fashion. The data collected by the bio-information unit is wirelessly forwarded to a bio-information modem that in turn forwards the collected data to a central web-hosted database where treatment providers can easily access the data collected.

[0011] Referring now to FIG. 1, a portable Bio-Information Unit 100 is worn, attached, or otherwise utilized by Subject 107 being monitored. Bio-Information Unit 100 will take readings from the one or more bio-sensors associated with it at predetermined or random intervals 24 hours a day, 7 days a week, 365 days a year. Periodically Subject 107 with Bio-Information Unit 100 comes within range of Bio-Information Modem 103. When Bio-Information Unit 100 is within range of Bio-Information Modem 103, and the timer indicates that it is time to communicate with Bio-Information Modem 103, the Bio-Information Unit 100 will transfer all the data taken from the readings collected and stored, along with any error indicators and any other diagnostic data stored to Bio-Information Modem 103. Bio-Information Modem 103 then stores all of this information for transmission to Bio-Information Network 104. After receiving all of the information from Bio-Information Unit 100, Bio-Information Modem 103 will check the stored data for any readings or errors. Either of these, or a trigger from a predetermined time interval, will cause Bio-Information Modem 103 to communicate with Bio-Information Network 104, typically through the telephone system via Communication Link 106. Once Communication Link 106 is established between Bio-Information Modem 103 and Bio-Information Network 104, Bio-Information Modem 103 will transfer all of the readings, errors, and any other diagnostic data it has stored to Bio-Information Network 104. Bio-Information Network 104 then analyzes the data received and separates and groups the data into a number of separate categories for reporting to Treatment Provider 105. The data can then be accessed by the monitoring personnel of Treatment Provider 105 through the use of secured dedicated

websites through the Internet **109** and Internet Connections **110** to Bio-Information Network **104**.

[0012] The communication link between Bio-Information Unit **100** and Bio-Information Modem **103** is established through a bi-directional radio frequency ("RF") Communication Link **102**. RF Communication Link **102** provides a means for Bio-Information Modem **103** to set up the appropriate reading schedules and communication schedules for Bio-Information Unit **100**. The reading schedules and communications schedules are set up by Treatment Provider **105** through Bio-Information Network **104**. RF Communication Link **102** also provides a means for Bio-Information Modem **103** to monitor the status of the operating program of Bio-Information Unit **100**, and to update this program when needed. RF Communication Link **102** also provides a means for Bio-Information Unit **100** to upload its stored readings, errors, and diagnostic data to Bio-Information Modem **103**.

[0013] All of the communication between Bio-Information Modem **103** and Bio-Information Unit **100** is sent over RF Communication Link **102** in a proprietary RF encoded format. This format is similar to a standardized serial TCP/IP format with RF encoding. To ensure that the data being sent over RF Communication Link **102** is valid, each packet sent from Bio-Information Unit **100** to Bio-Information Modem **103** must be validated by Bio-Information Modem **103** before being erased from memory by Bio-Information Unit **100**. The validation process insures that no data will be lost during the transfer should the transfer be interrupted by some type of interference, or if Subject **107** moves out of range of Bio-Information Modem **103** during the transfer.

[0014] Once Bio-Information Modem **103** has received all of the data from Bio-Information Unit **100**, it stores the data and then checks to see if there is any information in the data received that needs to be transmitted immediately. If not, Bio-Information Modem **103** will transmit the data on scheduled times only. Bio-Information Modem **103** is equipped with a Real Time and date Clock ("RTC") used to monitor the calendar date and the current time. This provides a means for Bio-Information Modem **103** to check on programmable schedules to see when the data should be transmitted to Bio-Information Network **104**.

[0015] Once Bio-Information Modem **103** decides that it is time to transmit data to Bio-Information Network **104**, it will turn off RF Communication Link **102** if it is currently on. Bio-Information Modem **103** will then turn on Modem Chip Set **326** (see FIG. 3) which is connected via a telephone line to Communication Link **106**. Bio-Information Modem **103** will then check to see if a dial tone is available. If no dial tone is available, then Bio-Information Modem **103** will log an alarm indicating no dial tone, and wait a predetermined period of time, such as one minute, before attempting to dial again. Once a dial tone is established, Bio-Information Modem **103** will dial the number to connect to Bio-Information Network **104**. When Bio-Information Network **104** answers the call, Modem Chip Set **326** will establish a connection via Communication Link **106**. Bio-Information Network **104** will then establish communication with Bio-Information Modem **103**.

[0016] Bio-Information Network **104** will first execute a series of inquiries used to validate Bio-Information Modem **103**. Once Bio-Information Modem **103** is validated, Bio-Information Network **104** will then retrieve all of the infor-

mation stored in Bio-Information Modem **103**. Each data packet sent from Bio-Information Modem **103** must be validated by Bio-Information Network **104** before it is erased from memory by Bio-Information Modem **103**. This validation process makes sure that no data will be lost during the transfer from Bio-Information Modem **103** to Bio-Information Network **104** if Communication Link **106** should be interrupted for whatever reason.

[0017] After all of the information has been received, Bio-Information Network **104** will check the status of the program stored in Bio-Information Modem **103**, as well as the status of the program stored in Bio-Information Unit **100**. If either program is out of date, then Bio-Information Network **104** will send an updated program to Bio-Information Modem **103**, which will update the program stored in Bio-Information Unit **100** upon the next communication session with Bio-Information Unit **100**. Bio-Information Network **104** will then update all schedule information for Bio-Information Modem **103** and Bio-Information Unit **100**.

[0018] Bio-Information Network **104** will then sort all of the data into the appropriate categories and decide if any immediate notification action needs to be taken. If notification is needed, then Bio-Information Network **104** will perform the desired notification operations, such as sending out a page, an e-mail, a phone mail message, a fax, etc. to monitoring personnel at Treatment Provider **105** via Communication Link **108**.

[0019] Treatment Provider **105** can access the data which triggered the alert by accessing the Internet **109** through Internet Connections **110** and logging into the appropriate secure web site. From the secure web site, Treatment Provider **105** can then review the alert, print reports of the desired data, as well as change any schedules or make any adjustments to the equipment operation, or contact Subject **102** if necessary.

[0020] FIG. 2 shows a block diagram of the Bio-Information Unit **100** of FIG. 1 where thicker arrows represent power circuits, and thinner arrows represent signal circuits. Referring now to FIG. 2, Bio-Information Unit **100** contains a micro-controller that functions as a Power Controller **205**. Power Controller **205** controls all of the power in Bio-Information Unit **100**. When the Battery **211** is inserted into Bio-Information Unit **100**, Power Controller **205** is activated by Stand By Power Source **210**, which causes Bio-Information Unit **100** to operate at a low voltage level. Once Power Controller **205** is initialized and running, it will turn on the main power to Bio-Information Unit **100** by activating Main Power Source **204**. Power Controller **205** will then operate at the main power level with the rest of the circuits. Another function of Power Controller **205** is to monitor the output power level of Battery **211** that powers Bio-Information Unit **100**. This is accomplished by running the raw battery voltage through a resistive voltage divider and then connecting it directly to Power Controller **205**. Power Controller **205** also controls the power to the analog circuits and an optional analog board, (which may be present in some types of Bio-Information Units **100**) through Analog Power Source **212**. The optional analog board provides a means of adapting Bio-Information Unit **100** to a large assortment of bio-medical equipment. Analog Power Source **212** in turn provides the power to the Analog to Digital ("A to D") Interface Chip **213** and the Sensor Interface Circuits **216**, so

that the circuits are not powered up the entire time that Bio-Information Unit **100** is turned on.

[0021] Another function of Power Controller **205** is to provide a real time clock. The time and date are downloaded to CPU **201** from Bio-Information Modem **103** and are then communicated to Power Controller **205**. This Process synchronizes the Bio-Information Unit **100** with the Bio-Information Modem **103**. This process will occur every time the two devices communicate with each other. The Bio-Information Modem **103** also synchronizes it's time and date with the Bio-Information Network **104** each time that they communicate. Power Controller **205** will then keep track of the time and date and automatically turn on Main Power Source **204** at scheduled times, which can be programmed by CPU **201**.

[0022] Power Controller **205** monitors all of the inputs that can cause Bio-Information Unit **100** to wake up due to some kind of stimulant condition existing. One condition is if a magnet is passed near Reed Relay **202**. Passing a magnet near Reed Relay **202** is a method that may be employed to wake up Bio-Information Unit **100** in order to take a reading at an unscheduled time. Any such activation of Bio-Information Unit **100** is processed as an alert. Monitoring personnel can note in the records that the alert event recorded was a result of Subject **107** actions, thereby providing a means of verifying that Subject **107** took a manual reading at the appropriate time.

[0023] Passing a magnet near Reed Relay **202** will cause it to open and close creating a pulsing effect at the power controllers monitoring input. When Power Controller **205** detects this pulsing input it will immediately turn on Main Power Source **204** and activate Bio-Information Unit **100**.

[0024] Bio-Information Unit **100** also contains CPU **201** which is a stand alone processor which typically has no internal memory component. In another embodiment of the invention, CPU **201** and Integrated Memory **203** may be combined together in the same chip. CPU **201** retrieves all of its instructions and data from Integrated Memory **203**. Integrated Memory **203** is divided internally into several different memory segments. There is a small segment of the memory dedicated to the boot strap program. The boot strap program is used to initialize Bio-Information Unit **100** when power is first applied. The boot strap program is a very basic program that will initialize CPU **201** and then check the validity of the main operating program that is stored in a larger section of Integrated Memory **203**. The boot strap program also has the capability of establishing communications through RF Communication Link **102** if the main program is not valid.

[0025] RF Communication Link **102** is established through the use of a serial to RF Transceiver **207** and RF Antenna **208**. CPU **201** will command Power Controller **205** to turn on RF Power Source **209**. Power Controller **205** will then activate RF Power Source **209** and supply all the RF components with low voltage. CPU **201** is connected to RF Transceiver **207** through RF Interface **206** which allows the serial signal from CPU **201** to be converted to the proper voltage for the RF transceiver circuits. By establishing RF Communication Link **102** the main program can then be downloaded into Bio-Information Unit **100** by Bio-Information Modem **103** if required. Once the boot strap program has verified that the main program is valid, it will then

switch operation to the main program segment in Integrated Memory **203**. If the main operating program was verified, then Bio-Information Unit **100** will switch operation to the main program segment in Integrated Memory **203** instead of establishing RF Communication Link **102**.

[0026] A to D Interface Chip **213** is a programmable A to D converter in that it allows for amplifier gain to be applied to the signals that are being monitored through the use of internal Amplifier Circuits **214** and software stored in Integrated Memory **203**, instead of using external hardware to amplify the signals. CPU **201** can then use software stored in Integrated Memory **203** to change the gain of all the A to D channels at any time. A to D Interface Chip **213** is used to convert data captured by Sensor Array **215**. Sensor Array **215** may have one or more sensors designed to capture one or more types of bio-information as discussed above. The signals from Sensor Array **215** are input to A to D Interface Chip **213** in analog format and are then converted to a digital signal and communicated through a serial link to CPU **201**.

[0027] After Bio-Information Unit **100** has been activated by Power Controller **205**, and it has confirmed all of the memory functions are good, it will read Sensor Array **215** and record all of the resulting data from each type of sensor that is being monitored at the time. After Bio-Information Unit **100** has completed reading Sensor Array **215**, it will then activate the RF circuits and wait to see if a RF signal is received from Bio-Information Modem **103**. If a signal is received from Bio-Information Modem **103**, Bio-Information Unit **100** will then retrieve all of the information stored in Integrated Memory **203** and transmit it to Bio-Information Modem **103**. If no signal is received then Bio-Information Unit **100** will turn off until the next scheduled wake up time.

[0028] FIG. 3 shows a block diagram of an embodiment of Bio-Information Modem **103** where thicker arrows represent power circuits, and thinner arrows represent signal circuits. FIGS. 4A-4D show a top and three elevation views of an embodiment of Modem **104**. Referring now to FIG. 3 and FIGS. 4A-4D, Bio-Information Modem **103** is powered by an external dc power supply (not shown in FIG. 3 or FIGS. 4A-4D). The dc power supply can be configured to plug into either a 115V AC supply or an international type power outlet. The dc power supply is plugged into an external power source and then plugged into the back of Bio-Information Modem **103** at a Main Power Input **338**. Main Power Input **338** is connected to Main Power Input Circuits **321**. Main Power Input Circuits **321** filter the power and make sure that the polarity of the power is correct and then distributes the power to Main Power Supply **322**, Modem Power Supply **325**, and RF Power Supply **328**. Main Power Input Circuits **321** also monitor the power for AC power failures. This is accomplished by running the DC power input through a resistive divider and then into CPU **317**.

[0029] Main Power Supply **322** supplies the power to CPU **317**, RS232 Interface or Analog Modem Selector **329**, RS232 Interface **330**, Serial EE Prom **337**, Battery Backup Circuits **324** and JTAG Connector **319**. Battery Backup Circuits **324** supply the power to Integrated Memory **318** and Real Time Clock **323**. The main power is applied as soon as Bio-Information Modem **103** is plugged in. The fact that Bio-Information Modem **103** is on is reflected by at least one LED that is illuminated in LED's **336**. LCD Display **320**

is also used to display any special instructions or request of Subject **107** by the monitoring personnel. Test results and critical sensor information can also be displayed on LCD Display **320**. LCD Display **320** will also display any schedule information that Subject **107** may need to be aware of.

[0030] Integrated Memory **318** is divided internally into several different memory segments. There is a small segment of the memory dedicated to the boot strap program. The boot strap program is used to initialize Bio-Information Modem **103** when power is first applied. The boot strap is a very basic program that will initialize CPU **317** and then check the validity of the main operating program that is stored in a larger section of Integrated Memory **318**. There is also an additional RAM component that supplies extra data storage capabilities. Serial EE Prom **337** is used to store all of the critical information for Bio-Information Modem **103** such as the serial number, device identification information and the phone numbers that should be called to connect to Bio-Information Network **104**. Bio-Information Modem **103** will retrieve and validate all of the critical information and will then validate the main operational program. If the main operational program is valid, Bio-Information Modem **103** will switch operation from the bootstrap program to the main operational program. Once the switch is made Bio-Information Modem **103** will contact Bio-Information Network **104** and report the latest power fail. If the main operational program is not valid than Bio-Information Modem **103** will try to contact Bio-Information Network **104** and get the main operational program downloaded to itself. The JTAG Connector **319** also provides a means of programming both the modem boot strap program and the main operational program into Integrated Memory **318**.

[0031] To connect to Bio-Information Network **104**, Bio-Information Modem **103** will check the input from the RS232 Interface or Analog Modem Selector **329** and see if there is a serial cable attached to Bio-Information Modem **103** at External RS232 Connector **332**, which is accessible by opening up the cover of Bio-Information Modem **103**. If there is, then Bio-Information Modem **103** will go into slave mode waiting for serial communications to come in through RS232 Interface **330**. This mode provides a means of manually issuing commands and loading programs and or data to Bio-Information Modem **103**. If there is no serial cable attached to Bio-Information Modem **103**, then CPU **317** will turn on Modem Power Supply **325**. After allowing Modem Chip Set **326** to power up and stabilize, CPU **317** will check for a dial tone. If no dial tone is identified, then CPU **317** will hang up and generate an alarm to indicate that the telephone line is not connected at External Phone Line Connector **327**. Bio-Information Modem **103** will then try again after a predefined delay period. External Hand Set Connector **331** receives the telephone wire that comes from the telephone hand set.

[0032] Once a dial tone has been established, CPU **317** will dial the telephone number for Bio-Information Network **104**. CPU **317** will then monitor Modem Chip Set **326** for an indication that a connection has been established with Bio-Information Network **104**. If CPU **317** determines that the telephone line is busy, or that there is no answer, then CPU **317** will hang up and log an alarm indicating that a connection could not be established. Bio-Information Modem **103** will then wait a predefined delay period and try to make

the connection again. Once the connection is established, Bio-Information Network **104** becomes the master and Bio-Information Modem **103** becomes the slave. Bio-Information Network **104** will then extract all of the pertinent information that it needs to validate Bio-Information Modem **103** and to update its status. It will then update Real Time Clock **323** so that Bio-Information Modem **103** is set to the proper time for the time zone where Bio-Information Modem **103** is currently located. Bio-Information Network **104** will then upload all data that has been stored in Bio-Information Modem **103** since the last upload. Bio-Information Network **104** then has the ability to download any number of specific monitoring instructions that need to be sent to Bio-Information Unit **100**, along with all of the schedule information for Bio-Information Modem **103** and Bio-Information Unit **100**. Bio-Information Network **104** will then tell Bio-Information Modem **103** to hang up and start operations.

[0033] CPU **317** will hang up and turn off the power to Modem Chip Set **326**. CPU **317** will then activate the RF circuits and try to establish RF Communication Link **102**. RF Communication Link **102** is established through the use of a serial to RF Transceiver **334** and the RF antenna **335**. CPU **317** is connected to RF transceiver **334** through RF Interface **333** which allows the serial signal from CPU **317** to be converted to the proper voltage for the RF transceiver circuits. CPU **317** will start sending a standard message out over the RF Communication Link **102**. This message is addressed to Bio-Information Unit **100**, so if Bio-Information Unit **100** is within range of Bio-Information Modem **103** and Bio-Information Unit **100** is active, then Bio-Information Unit **100** will answer the message with a status message indicating that Bio-Information Unit **100** is active and operating. Bio-Information Modem **103** will then become the master and Bio-Information Unit **100** will become the slave. Bio-Information Modem **103** will extract all of the status information from Bio-Information Unit **100** and will validate the operating program and any pertinent operating data need by Bio-Information Unit **100**. Bio-Information Modem **103** will then update the real time clock in Bio-Information Unit **100** so that Bio-Information Unit **100** and Bio-Information Modem **103** are on the same time. Bio-Information Modem **103** will then extract any sensor reading information as well as any error information from Bio-Information Unit **100**. Bio-Information Modem **103** will then turn off the RF signal. When the RF signal is turned off, Bio-Information Unit **100** will turn itself off and return to normal monitoring mode.

[0034] CPU **317** will then scan through the data just received and determine if any of the data needs to be sent immediately to Bio-Information Network **104**. If not, then CPU **317** will wait a predefined delay period and then start the polling sequence again. If there is data that needs to be transmitted to Bio-Information Network **104** immediately, or if the time clock indicates that it is a scheduled time to call Bio-Information Network **104**, then Bio-Information Modem **103** will go through the connection process and connect to Bio-Information Network **104**.

[0035] FIG. 5 shows a more detailed block diagram of Bio-Information Network **104**. Alert/sensor information is constantly being generated and monitored by the bio-information system components of the present invention. The following description will describe how and why the infor-

mation is generated and how the information is handled and processed once it is generated.

[0036] Once Bio-Information Unit 100 has been adjusted properly for utilization by Subject 107, the battery pack is inserted into Bio-Information Unit 100. When the battery makes electrical contact upon being inserted into Bio-Information Unit 100, an alert is generated indicating that power has been applied to Bio-Information Unit 100. Normal occurrences of these alerts are generated each time Bio-Information Unit 100 is attached to Subject 107 or each time that the battery is changed. The power up alerts provide a means for the monitoring personnel to verify that the equipment is on Subject 107 at the appropriate times. If Subject 107 does not have the equipment on at the appropriate time the monitoring personnel can respond appropriately in case there is a problem with Subject 107. Once Bio-Information Unit 100 is operational Subject 107 simply needs to wear or attach the sensor array required and go about their normal activities. The bio-information data will be collected continuously, and transmitted automatically to the Bio-Information Modem 103.

[0037] The alert described previously will cause the Bio-Information Unit 100 to attempt to communicate with the Bio-Information Modem 103 as soon as possible, overriding the normal scheduled communications programmed into the Bio-Information Modem 103 and Bio-Information Unit 100. The bio-information system uses the scheduled communications times to ensure that all equipment is operational under normal conditions. During normal operation there should be no reason for the equipment to override the schedules, and it will only communicate when scheduled. If no schedules were used, there would be no communication and no validation that readings were being taken and stored by Bio-Information Unit 100. If Bio-Information Unit 100 does not communicate at a scheduled communications time, Bio-Information Modem 103 will generate an alert that Bio-Information Unit 100 failed to communicate on schedule, along with the present time and date. This alert will be labeled as a Communications Alert by Situation Analyzer 124. If Bio-Information Unit 100 does not communicate with Bio-Information Modem 103 for a period of 24 hours, Bio-Information Modem 103 will generate a No Communications alert, along with the present time and date. This will also be labeled as a Communications Alert by Situation Analyzer 124. Thus, the normal flow of communications between Bio-Information Unit 100 and Bio-Information Modem 103 must exist or there will be alerts generated to inform the treatment providers that something is wrong with the system. Bio-Information Modem 103 communicates with Bio-Information Network 104 through Communication Server 126. The normal communication between these two devices is controlled by schedules programmed into the particular Bio-Information Modem 103 utilized with the particular Bio-Information Unit 100. Bio-Information network 104 also monitors these schedules. If Bio-Information Modem 103 fails to communicate when scheduled, Bio-Information Network 104 will generate a Communications Alert indicating that Bio-Information Modem 103 failed to communicate when scheduled. Thus, if the normal communications cycle between Bio-Information Modem 103 and Communication Server 126 is broken, then alerts will be generated to inform the supervising personnel that something is wrong with the system. This type of system architecture provides the means for equipment at each level of the

communications chain to generate alarms. This guarantees that if a piece of equipment anywhere in the chain of communication fails, there will be an alarm to report it. This type of architecture also provides constant monitoring without any active participation by Subject 107 being monitored. Bio-Information Unit 100 automatically collects the information from Sensor Array 215 and transmits it to Bio-Information Modem 103 whenever possible, or whenever scheduled, depending on which mode of operation is programmed into Bio-Information Unit 100.

[0038] Data input and data management are handled by Treatment Provider/Subject Database 134. Treatment Provider/Subject Database 134 is actually a combination of databases that support all of the processes in the Bio-Information Network 104. Treatment Provider/Subject Database 134 includes input and management of the Bio-Information Network 104 data, the Treatment Provider/Subject data, and any specific information relating to Treatment Provider 105, and the subject or patient data, including their individual monitoring and communications schedules and the device information for the Bio-Information Modems 103 and Bio-Information Units 100 assigned to them. This information includes what type of sensor arrays are being monitored by Bio-Information Unit 100, along with the special programs needed for Bio-Information Modem 103 and Bio-Information Unit 100 to operate correctly with the desired sensor configuration. By storing the programs in Bio-Information Network 104, Bio-Information Unit 100 can be generic in nature until it is assigned to a Subject 107 and the specific sensors that are to be monitored are assigned. After assigning the sensors, Bio-Information Network 104 will then select the appropriate software program required for monitoring the sensors and use it to remotely re-program Bio-Information Unit 100, thereby specializing the unit for use with the appropriate sensors.

[0039] Treatment Provider/Subject Database 134 stores all of the readings, errors, and other information that is received from all Bio-Information Modems 103 and Bio-Information Units 100 as well as any device information that needs to be stored and monitored. Treatment Provider/Subject Database 134 provides a complete historical record of all readings and alerts for all Subjects 107 being monitored in the bio-information system.

[0040] The Situation Analyzer 124 is used to parse the data and apply a known set of rules and instructions for handling the raw data and parsing it into a limited number of categories. This includes applying any special instructions specific to the types of sensors being monitored. These categories can be broken down as follows:

[0041] Reading Data: Includes all information that has been read by the sensor arrays.

[0042] Equipment Alert: Includes Power up alarms received from the Bio-Information Unit 100, equipment failure alerts and any type of sensor malfunction information or equipment failure that is received.

[0043] Communication Alerts: Includes No Modem Communication, No Bio-Information Unit Communication, Modem missed scheduled call-in time alerts, and Bio-Information Unit missed scheduled call-in time alerts.

[0044] Equipment Maintenance: Includes alerts for scheduled maintenance, non-scheduled maintenance, and software downloads.

[0045] Equipment Assignment: Includes alerts for equipment now assigned to a subject and equipment removed from a subject.

[0046] Situation Analyzer 124 will make inquires to Workflow Instructions 128 to get direction on what is the default or specific action that should be applied to the message that was just received. Situation Analyzer 124 will then use those instructions and any historical data relating to similar messages to make a decision as to what to do with the message just received. Situation Analyzer 124 can also monitor historical data and escalate the severity of alert messages if there is a pattern emerging in the data that would require more immediate attention. Situation Analyzer 124 can also monitor historical data to detect trends in the data and then provide feedback to Subject 107 automatically by sending messages to Bio-information Modem 103 to display the feedback information on LCD Display 320. Once Situation Analyzer 124 has made its decision, it will pass the message to Alert Manager 130. Alert Manager 130 will inquire to Workflow Instructions 128 for direction on what should be done with this message. Alert Manager 130 will then present the alert information to the monitoring personnel upon request and prompt them for some type of action required to address the alert. The main categories of alert management can be broken down as:

[0047] Review/Report the information.

[0048] Take Action: by monitoring personnel or some other person in a monitoring role.

[0049] Snooze the alert.

[0050] Log all action that is required for the alert.

[0051] Change the Status of the Alert: by taking the appropriate action the alert can now be resolved. Once resolved, the database will reflect this status and remove the Alert from the new information screens.

[0052] Situation Analyzer 124 will then check to see if the message that is being dealt with requires any type of immediate notification of a treatment provider. If it does, then Situation Analyzer 124 will send the message to Notification Server 132. Notification Server 132 will then inquire to Supervising Agency/Subject Database 134 to see what method of notification is preferred by the monitoring person, and then execute the notification method, such as sending an e-mail sending a fax, sending a phone mail message, or sending a page to the appropriate person.

[0053] Thus, the method and system of the present invention offers multiple levels of alert ranging from alerts generated by Bio-Information Unit 100, from Bio-Information Modem 103, and from Bio-Information Network 104. The flexible and changeable scheduling at the Subject 107 level allows for more timely intervention for all of the Subjects 107 being monitored who are having problems.

[0054] Having described the present invention, it will be understood by those skilled in the art that many changes in construction and circuitry and widely differing embodiments

and applications of the invention will suggest themselves without departing from the scope of the present invention.

1. (Canceled)

2. A system for continuous passive monitoring of bio-information of a human subject comprising:

a bio-information unit attached to the human subject, wherein said bio-information unit takes a plurality of bio-sensor readings at predetermined times without active participation by the human subject;

a bio-information modem in communication with said bio-information unit, wherein said plurality of bio-sensor readings are communicated from said bio-information unit to said bio-information modem at predetermined time intervals through radio frequency signals;

a bio-information network in communication with said bio-information modem, wherein said plurality of bio-sensor readings are communicated from said bio-information modem to said bio-information network at predetermined time intervals through a first communication link, and further wherein said bio-information network analyzes said plurality of bio-sensor readings to determine if an alert condition exists; and

a treatment provider in communication with said bio-information network, wherein said bio-information network communicates an alert to said treatment provider through a second communication link when said alert condition exists.

3. The system according to claim 2 further comprising:

a plurality of bio-information units each of which is attached to a one of a plurality of human subjects, wherein each of said plurality of bio-information units takes a plurality of bio-sensor readings at predetermined times without active participation by said plurality of human subjects;

a plurality of bio-information modems, wherein each of said plurality of bio-information modems is paired with and in communication with a one of said plurality of bio-information units attached to said one of a plurality of human subjects, wherein said plurality of bio-sensor readings are communicated from each of said plurality of bio-information units to its paired said plurality of bio-information modems at predetermined time intervals through a plurality of radio frequency signals, and further wherein each of said plurality of bio-information modems is in communication with said bio-information network wherein said plurality of bio-sensor readings are communicated from said plurality of bio-information modems to said bio-information network at predetermined time intervals through a plurality of first communication links; and

a plurality of treatment providers in communication with said bio-information network, wherein each of said plurality of human subjects are associated with a one of said plurality of treatment providers, and each of said plurality of treatment providers can access through an internet connection to said bio-information network said plurality of bio-sensor readings for each of said plurality of human subjects associated with said one of said plurality of treatment providers.

4. The system according to claim 3 wherein said bio-information network communicates automatically or on a periodic basis to said plurality of treatment providers said plurality of bio-sensor readings communicated from each of said plurality of bio-information modems paired to said plurality of bio-information units for each of said plurality of human subjects associated with a one of said plurality of treatment providers.

5. The system according to claim 2 wherein said bio-information unit communicates to said bio-information modem through said radio frequency signals any errors and diagnostic data.

6. The system according to claim 5 wherein said bio-information modem, upon receiving at least a one of said plurality of bio-sensor readings, said errors, and said diagnostic data, or upon a predetermined time interval occurring, will establish said first communication link with said bio-information network and communicate said at least a one of said plurality of bio-sensor readings, said errors, and said diagnostic data to said bio-information network.

7. The system according to claim 6 wherein said bio-information network, upon said first communication link being established with said bio-information modem, executes a series of inquiries to validate said bio-information modem.

8. The system according to claim 5 wherein said bio-information network further comprises:

a web-hosted database server for storing said plurality of bio-sensor readings, said errors, and said diagnostic data.

9. The system according to claim 8 wherein said treatment provider accesses said web-hosted database server through an internet connection and a secure dedicated web site.

10. The system according to claim 5 wherein said bio-information network analyzes said plurality of bio-sensor readings, said errors, and said diagnostic data into a plurality of categories, and if any immediate notification action needs to be taken, said bio-information network performs a notification operation to a monitoring personnel associated with said treatment provider.

11. The system according to claim 10 wherein said notification operation is a one of an e-mail message, a facsimile transmission, a page to a pager, a text message, a call to a telephone, and a call to a cellular telephone.

12. The system according to claim 10 wherein said treatment provider, through said web-hosted database server through said internet connection, customizes a frequency of taking said plurality of bio-sensor readings and customizes a method of notification for said notification operation.

13. The system according to claim 2 wherein each of said plurality of bio-sensor readings are time and date stamped by said bio-information unit.

14. The system according to claim 2 wherein said bio-information modem can transmit to said bio-information unit through radio frequency signals at least a one of a reading schedule, a communication schedule, a sensor configuration data, and an other operational information.

15. The system according to claim 2 wherein said bio-information unit stores said plurality of bio-sensor readings in an integrated memory in said bio-information unit until said predetermined time interval for communicating said plurality of bio-sensor readings to said bio-information modem occurs.

16. The system according to claim 15 wherein when said communication of said plurality of bio-sensor readings from said bio-information unit to said bio-information modem fails at said predetermined time interval, said bio-information unit repeats said communication attempt after waiting a specified time period until confirmation of transfer of said plurality of bio-sensor readings is received from said bio-information modem.

17. The system according to claim 2 wherein said bio-information modem stores said plurality of bio-sensor readings received from said bio-information unit in an integrated memory in said bio-information modem until said predetermined time interval for communicating said plurality of bio-sensor readings to said bio-information network occurs.

18. The system according to claim 17 wherein when said communication of said plurality of bio-sensor readings from said bio-information modem to said bio-information network fails at said predetermined time interval, said bio-information modem repeats said communication attempt after waiting a specified time period until confirmation of transfer of said plurality of bio-sensor readings is received from said bio-information network.

19. The system according to claim 2 wherein the continuous passive monitoring of bio-information of a human subject may be done twenty-four hours a day, seven days a week, 365 days a year.

20. The system according to claim 2 wherein said plurality of bio-sensor readings are at least a one of a blood oxygen reading, blood carbon dioxide reading, insulin level reading, heart rate reading, temperature reading, respiration reading, and any other biological data reading based on a specific bio-sensor in the bio-information unit.

21. A method for continuous passive monitoring of bio-information of a human subject comprising the steps of:

- (a) attaching a bio-information unit to the human subject;
- (b) taking a plurality of bio-sensor readings by said bio-information unit at predetermined times without active participation by the human subject;
- (c) communicating said plurality of bio-sensor readings from said bio-information unit to a bio-information modem at predetermined time intervals through radio frequency signals;
- (d) communicating said plurality of bio-sensor readings from said bio-information modem to a bio-information network at predetermined time intervals through a first communication link;
- (e) analyzing said plurality of bio-sensor readings by said bio-information network to determine if an alert condition exists; and
- (f) communicating an alert to a treatment provider through a second communication link when said alert condition exists.

22. The method according to claim 21 further comprising the steps of:

- attaching each of a plurality of bio-information units to a one of a plurality of human subjects;
- taking a plurality of bio-sensor readings by said plurality of bio-information units at predetermined times without active participation by said plurality of human subjects;

communicating said plurality of bio-sensor readings from said plurality of bio-information units to a plurality of bio-information modems at predetermined time intervals through a plurality of radio frequency signals, wherein each of said plurality of bio-information modems is paired with and in communication with a one of said plurality of bio-information units attached to said one of a plurality of human subjects;

communicating said plurality of bio-sensor readings from said plurality of bio-information modems to a bio-information network at predetermined time intervals through a plurality of first communication links;

analyzing said plurality of bio-sensor readings from said plurality of bio-information modems by said bio-information network to determine if any alert conditions exist; and

communicating a plurality of alerts to a plurality of treatment providers through a plurality of second communication links when said alert conditions exist, wherein each of said plurality of human subjects are associated with a one of said plurality of treatment providers, and each of said plurality of treatment providers can access through an internet connection to said bio-information network said plurality of bio-sensor readings for each of said plurality of human subjects associated with said one of said treatment providers.

**23.** The method according to claim 22 further comprising the step of:

communicating by said bio-information network automatically or on a periodic basis to said plurality of treatment providers said plurality of bio-sensor readings communicated from each of said plurality of bio-information modems paired to said plurality of bio-information units for each of said plurality of human subjects associated with a one of said plurality of treatment providers.

**24.** The method according to claim 21 further comprising the step of:

communicating by said bio-information unit to said bio-information modem through said radio frequency signals any errors and diagnostic data.

**25.** The method according to claim 24 further comprising the steps of:

establishing said first communication link with said bio-information network upon receiving at least a one of said plurality of bio-sensor readings, said errors, and said diagnostic data, or upon a predetermined time interval occurring;

validating by said bio-information network said bio-information modem by executing a series of inquiries to said bio-information modem; and

upon successful validation, communicating said at least a one of said plurality of bio-sensor readings, said errors, and said diagnostic data to said bio-information network through said first communication link.

**26.** The method according to claim 25 further comprising the step of:

storing said plurality of bio-sensor readings, said errors, and said diagnostic data in a web-hosted database server in said bio-information network.

**27.** The method according to claim 26 further comprising the step of:

accessing said web-hosted database server by said treatment provider through an internet connection and a secure dedicated web site.

**28.** The method according to claim 27 further comprising the steps of:

analyzing by said bio-information network said plurality of bio-sensor readings, said errors, and said diagnostic data into a plurality of categories; and

applying a set of rules to said plurality of categories; and

communicating an automatic alert to a monitoring personnel associated with said treatment provider when a rule is satisfied.

**29.** The method according to claim 28 wherein said automatic alert is a one of an e-mail message, a facsimile transmission, a page to a pager, a text message, a call to a telephone, and a call to a cellular telephone.

**30.** The method according to claim 28 further comprising the step of:

customizing, by said treatment provider through said web-hosted database server through said internet connection, a frequency of taking said plurality of bio-sensor readings and a method of notification for said automatic alert.

**31.** The method according to claim 21 further comprising the step of:

time and date stamping by said bio-information unit each of said plurality of bio-sensor readings.

**32.** The method according to claim 21 further comprising the step of:

transmitting by said bio-information modem through radio frequency signals to said bio-information unit at least a one of a reading schedule, a communication schedule, a sensor configuration data, and an other operational information.

**33.** The method according to claim 21 further comprising the step of:

storing said plurality of bio-sensor readings in an integrated memory in said bio-information unit until said predetermined time interval for communicating said plurality of bio-sensor readings to said bio-information modem occurs.

**34.** The method according to claim 33 further comprising the step of:

when said communication of said plurality of bio-sensor readings from said bio-information unit to said bio-information modem fails at said predetermined time interval, repeating by said bio-information unit said communication attempt after waiting a specified time period until confirmation of transfer of said plurality of bio-sensor readings is received from said bio-information modem.

**35.** The method according to claim 21 further comprising the step of:

storing said plurality of bio-sensor readings in an integrated memory in said bio-information modem until

said predetermined time interval for communicating said plurality of bio-sensor readings to said bio-information network occurs.

**36.** The method according to claim 35 further comprising the step of:

when said communication of said plurality of bio-sensor readings from said bio-information modem to said bio-information network fails at said predetermined time interval, repeating by said bio-information modem said communication attempt after waiting a specified time period until confirmation of transfer of said plurality of bio-sensor readings is received from said bio-information network.

**37.** The method according to claim 21 wherein steps (b) through (f) may be performed twenty-four hours a day, seven days a week, 365 days a year.

**38.** A bio-information unit for continuous passive remote monitoring of a human subject comprising:

a processing means;

a configurable sensor array connectable to and controlled by said processing means for taking a plurality of bio-sensor readings of the human subject at predetermined times without active participation by the human subject; and

a radio frequency transceiver means connectable to and controlled by said processing means for transmitting said plurality of bio-sensor readings through radio frequency signals.

**39.** The bio-information unit of claim 38 further comprising:

a battery for supplying power to the bio-information unit; and

an attachment means for attaching the bio-information unit to the human subject.

**40.** The bio-information unit of claim 39 further comprising:

a bio-information modem in communication with the bio-information unit, wherein said bio-information unit communicates said plurality of bio-sensor readings to said bio-information modem through said radio frequency signals through said radio frequency transceiver.

**41.** The bio-information unit of claim 40 further comprising:

an integrated memory connectable to said processing means; and

a main program executable by said processing means for controlling the operation of the bio-information unit, wherein said main program is downloadable from said bio-information modem through said radio frequency signals to said radio frequency transceiver means through said processing means for storage in said integrated memory.

**42.** The bio-information unit of claim 41 further comprising:

a communication schedule stored in said integrated memory, wherein the bio-information unit attempts to communicate with said bio-information modem at times designated in said communication schedule, and

further wherein, when the bio-information unit fails to communicate with said bio-information modem at a scheduled communication time, said bio-information modem generates a communication alert along with a date and time of the failed communication, and further wherein, when the bio-information unit fails to communicate with said bio-information modem for a predetermined period of time, said bio-information modem generates a no bio-information unit communication alert along with a present date and time.

**43.** The bio-information unit of claim 42 further comprising:

a reed relay connectable to said processing means, wherein passing a magnet in proximity to said reed relay overrides said communication schedule and activates the bio-information unit to take another plurality of bio-sensor readings with said configurable sensor array, and the bio-information unit attempts to communicate said another plurality of bio-sensor readings through said radio frequency transceiver through said radio frequency signals to said bio-information modem.

**44.** The bio-information unit of claim 38 wherein the continuous remote monitoring of the human subject may be done twenty-four hours a day, seven days a week, 365 days a year.

**45.** The bio-information unit of claim 38 wherein said configurable sensor array further comprises:

at least one sensor, wherein said at least one sensor is designed to capture at least one of a blood oxygen reading, blood carbon dioxide reading, insulin level reading, heart rate reading, temperature reading, respiration reading, and any other biological data reading based on said at least one sensor's design.

**46.** A method for continuous remote bio-information monitoring of a human subject with a bio-information unit, the method comprising the steps of:

(a) taking a plurality of bio-sensor readings with a configurable sensor array of the bio-information unit at predetermined times without active participation by the human subject; and

(b) transmitting with a radio frequency transceiver of the bio-information unit through radio frequency signals said plurality of bio-sensor readings and diagnostic data.

**47.** The method according to claim 46 further comprising the step of:

performing steps (a) and (b) under the control of a central processing unit within the bio-information unit.

**48.** The method according to claim 47 further comprising the steps of:

inserting a battery within the bio-information unit; and

attaching the bio-information unit to the human subject.

**49.** The method according to claim 48 further comprising the steps of:

communicating said plurality of bio-sensor readings to a bio-information modem through said radio frequency signals through said radio frequency transceiver.

**50.** The method according to claim 48 further comprising the step of:

downloading a main program from said bio-information modem through said radio frequency signals to said radio frequency transceiver to said central processing unit for storage in an integrated memory connectable to said central processing unit, wherein said main program is executed by said central processing unit for controlling the operation of said configurable sensor array and said radio frequency transceiver.

**51.** The method according to claim 50 further comprising the step of:

storing a communication schedule in said integrated memory, wherein said bio-information unit attempts to communicate with said bio-information modem at times designated in said communication schedule.

**52.** The method according to claim 51 further comprising the steps of:

when the bio-information unit fails to communicate with said bio-information modem at a scheduled communication time of said communication schedule, generating a communication alert by said bio-information modem along with a date and time of the failed communication; and

overriding said communication schedule by the bio-information unit and attempting to communicate with said bio-information modem after waiting a specified time period until confirmation of said attempting to communicate is received from said bio-information modem.

**53.** The method according to claim 51 further comprising the step of:

when the bio-information unit fails to communicate with said bio-information modem for a predetermined period of time, generating a no bio-information unit communication alert by said bio-information modem along with a present date and time.

**54.** The method according to claim 51 further comprising the step of:

activating said bio-information unit and overriding said communication schedule by passing a magnet in proximity to a reed relay connectable to said central processing unit, wherein once activated, said bio-information unit takes a bio-sensor reading with said configurable sensor array, and attempts to communicate said bio-sensor reading through said radio frequency transceiver through said radio frequency signals to said bio-information modem.

**55.** The method according to claim 46 wherein steps (a) and (b) may be performed twenty-four hours a day, seven days a week, 365 days a year.

**56.** A bio-information modem for use with a continuous remote bio-information unit attached to a human subject, and for use with a bio-information network, the bio-information modem comprising:

a radio frequency transceiver for communicating bi-directional radio frequency signals with the continuous remote bio-information unit, wherein said radio frequency signals contain a plurality of data;

a central processing unit connectable to said radio frequency transceiver, wherein said central processing unit processes said plurality of data to determine if at least one alert condition exists; and

a bio-information modem chip set connectable to said central processing unit, wherein when said at least one alert condition exists, a communication link is established by said central processing unit through said bio-information modem chip set to the bio-information network, and further wherein said central processing unit communicates an alert over said communication link to the bio-information network.

**57.** The bio-information modem according to claim 56 wherein said central processing unit controls a plurality of processes, said plurality of processes comprising:

a schedule process that controls a plurality of communication events between the continuous remote bio-information unit and the bio-information modem, and between the bio-information modem and the bio-information network;

a monitoring process that monitors said bi-directional radio frequency signals, containing said plurality of data, between the continuous remote bio-information unit and the bio-information modem; and

an analysis process for analyzing said plurality of data for said at least one alert condition.

**58.** The bio-information modem according to claim 56 wherein said plurality of data further comprises:

a set of operating instructions;

a sensor configuration data;

an operating data;

a time and date synchronization information for the continuous remote bio-information unit; and

a plurality of monitoring data received from the continuous remote bio-information unit.

**59.** The bio-information modem according to claim 58 wherein said central processing unit communicates through said bio-information modem chip set to the bio-information network over said communication link at least a one of:

said plurality of monitoring data;

a time and date synchronization information;

a schedule information;

an operating data for the continuous remote bio-information unit;

a bio-information modem operating program information; and

a continuous remote bio-information unit operating program.

**60.** The bio-information modem according to claim 58 wherein said plurality of monitoring data further comprises:

a plurality of bio-sensor readings taken of the human subject;

a plurality of diagnostic data; and

when an error has been detected by the continuous remote bio-information unit, an error data.

61. The bio-information modem according to claim 56 wherein when said central processing unit communicates said alert to the bio-information network, said bio-information network analyzes said alert according to a rules-based database, and based on said analysis, said bio-information network may send an automatic alert to a treatment provider or to a designated individual over a new communication link.

62. The bio-information modem according to claim 56 further comprising:

an LCD display connectable to said central processing unit for displaying a plurality of status messages regarding the bio-information modem, wherein said plurality of status messages are instructions to the human subject that the continuous remote bio-information unit needs to communicate with the bio-information modem or perform a type of operation.

63. The bio-information modem according to claim 56 further comprising:

an integrated memory connectable to said central processing unit;

a main operating program stored in said integrated memory; and

a main power input circuits for receiving power from an external source, wherein when said power is first received, said main power input circuits provide power to said central processing unit, wherein said central processing unit checks a validity of said main operating program, wherein if said main operating program is invalid, said bio-information modem chip set attempts to establish a communication link to the bio-information network to download a valid version of said main operating program.

64. The bio-information modem according to claim 63 further comprising:

a real time clock connectable to said central processing unit, wherein said real time clock is updated when said communication link is established with the bio-information network, and further wherein the bio-information network uploads said plurality of data from the bio-information modem.

65. The bio-information modem according to claim 63 further comprising:

a phone line connected to the bio-information modem for establishing said communication link.

66. The bio-information modem according to claim 56 wherein the continuous remote bio-information unit monitoring of the human subject may be done twenty-four hours a day, seven days a week, 365 days a year.

67. A method for using a bio-information modem to process data received from a continuous remote bio-information unit attached to a human subject, and for use with a bio-information network, the method comprising the steps of:

(a) communicating bi-directionally with a radio frequency transceiver in the bio-information modem radio frequency signals with the continuous remote bio-information unit, wherein said radio frequency signals contain the data;

(b) processing by said central processing unit the data to determine if at least one alert condition exists;

(c) when said at least one alert condition exists, establishing a communication link by said central processing unit through a bio-information modem chip set to a bio-information network; and

(d) communicating by said central processing unit an alert over said communication link to said bio-information network.

68. The method according to claim 67 further comprising the steps of:

controlling by said central processing unit a schedule process for scheduling a plurality of communication events between the continuous remote bio-information unit and the bio-information modem, and between the bio-information modem and the bio-information network;

controlling by said central processing unit a monitoring process that monitors said radio frequency signals, containing the data, between the continuous remote bio-information unit and the bio-information modem; and

controlling by said central processing unit an analysis process for analyzing the data for said at least one alert condition.

69. The method according to claim 67 wherein the data further comprises:

a set of operating instructions;

a sensor configuration data;

an operating data;

a time and date synchronization information for the continuous remote bio-information unit; and

a plurality of monitoring data received from the continuous remote bio-information unit.

70. The method according to claim 69 further comprising the steps of:

communicating by said central processing unit through said bio-information modem chip set to the bio-information network over said communication link at least a one of said plurality of monitoring data, a time and date synchronization information, a schedule information, an operating data for the continuous remote bio-information unit, a bio-information modem operating program information, and a continuous remote bio-information unit operating program.

71. The method according to claim 69 wherein said plurality of monitoring data further comprises:

a plurality of bio-sensor readings taken of the human subject;

a plurality of diagnostic data; and

when an error has been detected by the continuous remote bio-information unit, an error data.

72. The method according to claim 67 further comprising the steps of:

analyzing by the bio-information network said alert according to a rules-based database; and

based on said analysis, sending an automatic alert to a treatment provider or to a designated individual over a new communication link.

**73.** The method according to claim 67 further comprising the step of:

displaying on an LCD display of the bio-information modem a plurality of status messages regarding the bio-information modem, wherein said plurality of status messages are instructions to the human subject that the continuous remote bio-information unit needs to communicate with the bio-information modem or perform a type of operation.

**74.** The method according to claim 67 further comprising the steps of:

connecting the bio-information modem to a power source;  
receiving power in said central processing unit;

checking by said central processing unit a validity of a bio-information modem main operating program for the bio-information modem stored in an integrated memory;

checking by said central processing unit a validity of a monitoring main operating program for the continuous remote bio-information unit stored in said integrated memory;

when at least a one of said bio-information modem main operating program and said monitoring main operating program is invalid, establishing a communication link by said bio-information modem chip set to a bio-information network;

downloading to the bio-information modem from the bio-information network a valid version of at least a one of said bio-information modem main operating program and said monitoring main operating program;

storing at least a one of said bio-information modem main operating program and said monitoring main operating program in said integrated memory;

updating a real time clock of the bio-information modem;  
and

uploading by the bio-information network the data from the bio-information modem.

**75.** The method according to claim 74 wherein said establishing step further comprises the steps of:

(1) checking by said central processing unit for a dial tone of a phone line connected to the bio-information modem;

(2) if no dial tone is detected, generating a no phone line connected alarm by said central processing unit;

(3) waiting by said central processing unit a predefined period of time; and

repeating steps (1) through (3) until a dial tone is detected.

**76.** The method according to claim 75 further comprising the steps of:

(4) when a dial tone is detected by said central processing unit, dialing a phone number for the bio-information network;

(5) monitoring by said bio-information modem chip set if said communication link is established to the bio-information network;

(6) if at least a one of a busy signal and a no answer is detected, generating a no connection alarm by said central processing unit;

(7) waiting by said central processing unit a predefined period of time; and

(8) repeating steps (4) through (7) until said communication link is established.

**77.** The method according to claim 76 further comprising the step of:

once said communication link is established, downloading a monitoring instructions, a schedule information for said bio-information modem, and a schedule information for the continuous remote bio-information unit for later delivery to the continuous remote bio-information unit; and

downloading a hang up instruction to the bio-information modem.

**78.** The method according to claim 77 further comprising the steps of:

once said hang up instruction is downloaded, hanging up by said central processing unit and powering off said bio-information modem chip set;

activating said radio frequency transceiver;

communicating a standard message over said radio frequency signals to the continuous remote bio-information unit;

when the continuous remote bio-information unit is within a range of the bio-information modem, receiving an answer message over said radio frequency signals sent from the continuous remote bio-information unit;

extracting by the bio-information modem the data from the continuous remote bio-information unit;

validating by the bio-information modem an operating program of the continuous remote bio-information unit;

updating by the bio-information modem a real time clock of the continuous remote bio-information unit;

downloading said schedule information for the continuous remote bio-information unit; and

terminating said radio frequency signals sent from the bio-information modem to the continuous remote bio-information unit.

**79.** The method according to claim 78 further comprising the step of:

when the continuous remote bio-information unit is not within said range of the bio-information modem, terminating said radio frequency signals; and

waiting a predefined period of time before recommunicating said standard message over said radio frequency signals to the continuous remote bio-information unit.

**80.** The method according to claim 78 further comprising the steps of:

scanning by said central processing unit the data to determine if an immediate alert needs to be communicated to the bio-information network;

when said immediate alert needs to be communicated, establishing a communication link to the bio-information network; and

when there is no said immediate alert to be communicated, waiting a predefined period of time before activating said radio frequency transceiver again.

**81.** The method according to claim 67 wherein steps (a) through (d) may be performed twenty-four hours a day, seven days a week, 365 days a year.

**82.** A bio-information network for use with a bio-information modem and a continuous remote bio-information unit attached to a human subject, the bio-information network comprising:

a communication server, wherein said communication server receives raw data over a communication link from the bio-information modem, wherein said raw data is gathered by the continuous remote bio-information unit attached to the subject and transmitted to the bio-information modem;

a situation analyzer connectable to said communication server, wherein said situation analyzer parses said raw data through a predetermined set of rules into a plurality of messages;

a workflow instructions connectable to said situation analyzer, wherein said situation analyzer queries said workflow instructions for an action to be applied to each of said plurality of messages;

a treatment provider/subject database connectable to said situation analyzer for storing said raw data, for storing information on the human subject, treatment provider, and a monitoring personnel monitoring the human subject, and for storing a method of notification predetermined by said monitoring personnel; and

a notification server connectable to said situation analyzer, wherein when said situation analyzer determines that said action to be applied to a one of said plurality of messages requires an immediate notification of said monitoring personnel, said situation analyzer will communicate said one of said plurality of messages to said notification server, and further wherein said notification server queries said treatment provider/subject database to determine a predetermined notification method, and executes said predetermined notification method to communicate a one of said plurality of messages to said monitoring personnel.

**83.** The bio-information network according to claim 82 wherein said communication server, upon establishment of said communication link with the bio-information modem, executes a series of inquiries to validate said bio-information modem.

**84.** The bio-information network according to claim 82 further comprising:

an alert manager connectable to said situation analyzer and to said workflow instructions, wherein said situation analyzer passes each of said plurality of messages

to said alert manager, and further wherein said alert manager categorizes each of said plurality of messages into a one of a plurality of alert management categories for presentation to a monitoring person at a monitoring station.

**85.** The bio-information network according to claim 84 wherein said plurality of alert management categories further comprises:

a review/report;

a take action;

a snooze alert;

a log action required; and

a change the status of alert.

**86.** The bio-information network according to claim 82 wherein said treatment provider/subject database further comprises:

a treatment center information for a treatment center associated with said treatment provider;

a historical record of all previously received raw data; and

a patient data for the human subject, said patient data further comprising a reading schedule, a communication schedule, a device information for the continuous remote bio-information unit, and a device information for the bio-information modem in communication with the continuous remote bio-information unit.

**87.** The bio-information network according to claim 82 wherein said situation analyzer categorizes said plurality of messages into a plurality of categories, said plurality of categories further comprising:

an equipment alert, including a power up alarm from the continuous remote bio-information unit, and an equipment failure alert;

a communication alert, including a no bio-information modem communication, a no continuous remote bio-information unit communication, a bio-information modem missed scheduled communication, and a continuous remote bio-information unit missed scheduled communication;

an equipment maintenance, including a scheduled maintenance, a non-scheduled maintenance, and a software download maintenance; and

an equipment assignment, including an equipment assigned and an equipment removed.

**88.** The bio-information network according to claim 87 wherein said situation analyzer, in categorizing said plurality of messages, analyzes historical data relating to similar messages in making categorization decisions.

**89.** The bio-information network according to claim 88 wherein said situation analyzer analyzes said historical data to detect data trends and provide feedback to the human subject by sending messages related to the data trends to the bio-information modem for output on an LCD display of the bio-information modem.

**90.** The bio-information network according to claim 82 wherein the continuous remote bio-information unit monitoring of a human subject is done twenty-four hours a day, seven days a week, 365 days a year.

**91.** The bio-information network according to claim 82 wherein said treatment provider/subject database further comprises:

a plurality of programs for monitoring a plurality of sensors in the continuous remote bio-information unit, wherein once a sensor configuration has been assigned to the continuous remote bio-information unit, said treatment provider/subject database selects from said plurality of programs a set of programs necessary for said sensor configuration, and downloads said set of programs to the bio-information modem, which in turn downloads said set of programs to the continuous remote bio-information unit.

**92.** A method for using a bio-information network to process raw data received via a bio-information modem from a continuous remote bio-information unit attached to a human subject, the method comprising the steps of:

- (a) receiving in a communication server in the bio-information network the raw data over a communication link from the bio-information modem, wherein the raw data is gathered by the continuous remote bio-information unit attached to the subject and is transmitted to the bio-information modem;
- (b) parsing with a situation analyzer said raw data through a predetermined set of rules into a plurality of messages;
- (c) determining with a workflow instructions an action to be applied to each of said plurality of messages;
- (d) storing in a treatment provider/subject database said raw data, an information on the human subject, an information on a treatment provider associated with the human subject, a predetermined notification method for notifying a monitoring personnel of said treatment provider associated with the human subject; and
- (e) when said action to be applied to a one of said messages requires an immediate notification of said monitoring personnel, executing with a notification server said predetermined notification method to communicate a one of said plurality of messages to said monitoring personnel.

**93.** The method according to claim 92 wherein said receiving step further comprises:

upon establishing said communication link, validating by said communication server said bio-information modem by executing a series of inquiries to said bio-information modem.

**94.** The method according to claim 92 wherein said predetermined notification method is a one of an e-mail message, a facsimile transmission, a page to a pager, a text message, a call to a telephone, and a call to a cellular telephone.

**95.** The method according to claim 92 further comprising the step of:

categorizing by an alert manager each of said plurality of messages into a one of a plurality of alert management categories for presentation to said monitoring personnel at a monitoring station, wherein said plurality of alert management categories is a one of a review/report, a take action, a snooze alert, a log action required, and a change the status of alert.

**96.** The method according to claim 95 further comprising the steps of:

analyzing by said situation analyzer a current message together with a historical raw data related to said current message; and

escalating said current message to a higher one of said plurality of alert management categories when a pattern is detected by said analyzing step that would require more immediate attention.

**97.** The method according to claim 95 further comprising the steps of:

downloading by the bio-information network said reading schedule and said communication schedule to said bio-information modem;

downloading by said bio-information modem said reading schedule and said communication schedule to the continuous remote bio-information unit;

when a scheduled communication between said communication server and said bio-information modem fails to occur, generating by said communication server a communication alert; and

communicating said communication alert to said monitoring station.

**98.** The method according to claim 92 further comprising the step of:

storing in said treatment provider/subject database a treatment center information for a treatment center associated with said treatment provider, a historical record of all previously received raw data, and a patient data for the human subject, said patient data further comprising a reading schedule, a communication schedule, a device information for the continuous remote bio-information unit, and a device information for the bio-information modem in communication with the continuous remote bio-information unit.

**99.** The method according to claim 92 wherein said parsing with a situation analyzer step further comprises the step of:

categorizing each of said plurality of messages into a one of a plurality of categories, wherein said plurality of categories is a one of an equipment alert, including a power up alarm from the continuous remote bio-information unit and an equipment failure alert; a communication alert, including a no bio-information modem communication, a no continuous remote bio-information unit communication, a bio-information modem missed scheduled communication, and a continuous remote bio-information unit missed scheduled communication; an equipment maintenance, including a scheduled maintenance, a non-scheduled maintenance, and a software download maintenance; and an equipment assignment, including an equipment assigned and an equipment removed.

**100.** The method according to claim 99 wherein said categorizing each of said plurality of messages into a one of a plurality of categories step further comprises:

analyzing historical data relating to similar messages in making categorization decisions.

**101.** The method according to claim 100 wherein said analyzing historical data step further comprises:

analyzing said historical data to detect a data trend; and based on said data trend, sending a message related to said data trend to the bio-information modem for output on an LCD display of the bio-information modem to provide feedback to the human subject.

**102.** The method according to claim 92 wherein steps (a) through (e) may be performed twenty-four hours a day, seven days a week, 365 days a year.

**103.** The method according to claim 92 further comprising the steps of:

assigning by said treatment provider/subject database a sensor configuration to the continuous remote bio-information unit for the human subject;

selecting by said treatment provider/subject database, based upon said sensor configuration, a set of programs from a plurality of programs stored in said treatment provider/subject database, wherein a plurality of sensors in the continuous remote bio-information unit are monitored by a one of said plurality of programs, and further wherein said set of programs are necessary for monitoring said sensor configuration;

downloading by said treatment provider/subject database said set of programs to the bio-information modem; and

downloading by the bio-information modem said set of programs to the continuous remote bio-information unit.

\* \* \* \* \*

专利名称(译)	生物信息传感器监测系统和方法		
公开(公告)号	<a href="#">US20040236189A1</a>	公开(公告)日	2004-11-25
申请号	US10/441960	申请日	2003-05-19
[标]申请(专利权)人(译)	HAWTHORNE JEFFREY SCOTT IIAMS MICHAEL LEONARD TUBB 格伦夏尔 STOLL 理查德 SHOFFNER GARY ALAN		
申请(专利权)人(译)	HAWTHORNE JEFFREY SCOTT IIAMS MICHAEL LEONARD TUBB 格伦夏尔 STOLL RICHARD A. SHOFFNER GARY ALAN		
当前申请(专利权)人(译)	HAWTHORNE JEFFREY SCOTT IIAMS MICHAEL LEONARD TUBB 格伦夏尔 STOLL RICHARD A. SHOFFNER GARY ALAN		
[标]发明人	HAWTHORNE JEFFREY SCOTT IIAMS MICHAEL LEONARD TUBB GLENN CHARLES STOLL RICHARD A SHOFFNER GARY ALAN		
发明人	HAWTHORNE, JEFFREY SCOTT IIAMS, MICHAEL LEONARD TUBB, GLENN CHARLES STOLL, RICHARD A. SHOFFNER, GARY ALAN		
IPC分类号	A61B5/00		
CPC分类号	G06F19/3412 G06F19/3418 Y10S128/92 A61B5/0022 G16H40/40 G16H40/67		
其他公开文献	US7311665		
外部链接	<a href="#">Espacenet</a> <a href="#">USPTO</a>		

#### 摘要(译)

生物信息监测系统利用远程便携式生物信息单元被动地监测患者，该远程便携式生物信息单元在选定的时间间隔以及随机时间进行各种生物信息测量而无需患者干预。当生物信息单元接近调制解调器时，测量结果被转换成数字信号，该数字信号从生物信息单元发送到调制解调器。信号存储在调制解调器中并上传到中央监控网络。可以从中央监控网络向治疗提供者发送自动警报。治疗提供者还可以通过互联网通过安全的专用网站访问信息。

