

US009482927B2

(12) **United States Patent**  
**Carralero et al.**

(10) **Patent No.:** **US 9,482,927 B2**  
(45) **Date of Patent:** **Nov. 1, 2016**

(54) **OPTICAL SENSOR INTERROGATION SYSTEM**

USPC ..... 385/12, 13, 15, 16, 125  
See application file for complete search history.

(75) Inventors: **Michael Carralero**, Huntington Beach, CA (US); **Ty A. Larsen**, Everett, WA (US)

(56) **References Cited**

(73) Assignee: **The Boeing Company**, Chicago, IL (US)

U.S. PATENT DOCUMENTS

(\* ) Notice: Subject to any disclaimer, the term of this patent is extended or adjusted under 35 U.S.C. 154(b) by 951 days.

4,492,121 A 1/1985 Lehto  
6,075,915 A \* 6/2000 Koops et al. .... 385/125  
6,222,954 B1 4/2001 Riza  
6,301,420 B1 \* 10/2001 Greenaway et al. .... 385/126  
6,691,007 B2 2/2004 Haugse et al.  
7,062,140 B2 \* 6/2006 Bjarklev et al. .... 385/125

(Continued)

(21) Appl. No.: **12/589,668**

FOREIGN PATENT DOCUMENTS

(22) Filed: **Oct. 26, 2009**

CN 2663979 Y 12/2004  
JP H0368815 A 3/1991

(65) **Prior Publication Data**

US 2011/0097031 A1 Apr. 28, 2011

(Continued)

(51) **Int. Cl.**

**G02B 6/12** (2006.01)  
**G02B 6/42** (2006.01)  
**G02B 6/26** (2006.01)  
**G02F 1/295** (2006.01)  
**A61B 5/00** (2006.01)  
**G01N 21/55** (2014.01)  
**G01D 5/26** (2006.01)  
**G01N 21/47** (2006.01)  
**G01B 9/02** (2006.01)  
**G02B 6/122** (2006.01)

OTHER PUBLICATIONS

International Search Report and Written Opinion of PCT/US2010/050921; Sep. 21, 2011; 16 pages.

(Continued)

*Primary Examiner* — Thomas A Hollweg

*Assistant Examiner* — Mary El Shammaa

(74) *Attorney, Agent, or Firm* — Armstrong Teasdale LLP

(52) **U.S. Cl.**

CPC ..... **G02F 1/295** (2013.01); **A61B 5/0066** (2013.01); **G01D 5/268** (2013.01); **G01N 21/55** (2013.01); **A61B 5/0059** (2013.01); **G01B 9/02091** (2013.01); **G01B 2290/45** (2013.01); **G01N 21/4795** (2013.01); **G01N 2201/068** (2013.01); **G01N 2201/088** (2013.01); **G02B 6/1225** (2013.01)

(57) **ABSTRACT**

Apparatus and a method for monitoring various conditions of a vehicle structure including an optical sensor comprising an optical fiber bearing a photonic crystal mounted to one end, an interrogation system including an optical signal generator interfacing with one or more of the optical sensors located remotely from the interrogation module, and a method of monitoring the vehicle structural health using the interrogation system.

(58) **Field of Classification Search**

CPC A61B 5/0066; A61B 5/0059; G01B 9/0291; G02B 2290/45; G01N 21/4795

**10 Claims, 4 Drawing Sheets**

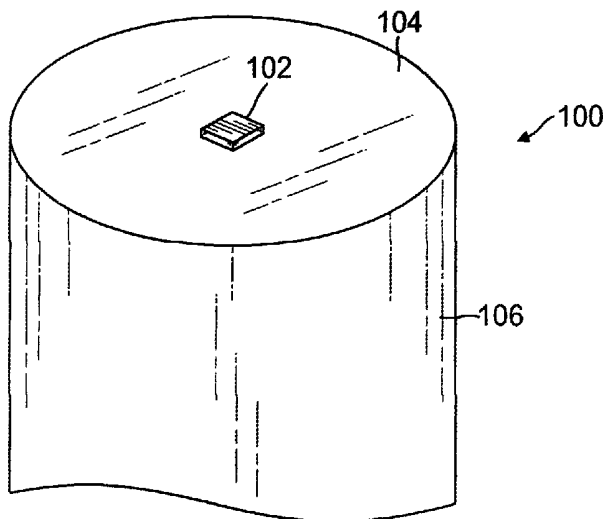

(56)

References Cited

U.S. PATENT DOCUMENTS

7,289,221	B2 *	10/2007	Wang et al. ....	356/477
7,359,587	B2 *	4/2008	Beausoleil et al. ....	385/14
7,379,648	B1	5/2008	Brooks et al.	
2001/0054681	A1 *	12/2001	Hamada .....	250/227.11
2003/0077058	A1 *	4/2003	Russell et al. ....	385/125
2004/0208449	A1 *	10/2004	Chen et al. ....	385/39
2005/0053352	A1 *	3/2005	McKain et al. ....	386/46
2005/0175274	A1 *	8/2005	Gunn, III .....	385/16
2005/0201660	A1 *	9/2005	Grot et al. ....	385/12
2008/0129980	A1 *	6/2008	Dhawan et al. ....	356/12
2009/0208163	A1 *	8/2009	Kilic et al. ....	385/12
2009/0263079	A1 *	10/2009	Shapira et al. ....	385/16

FOREIGN PATENT DOCUMENTS

JP	2004117041	A	4/2004
JP	2006524793	A	11/2006
JP	2007232509	A	9/2007
JP	2007293259	A	11/2007
WO	2008086448	A2	7/2008

OTHER PUBLICATIONS

Jung, I. et al; Photonic Crystal Fiber Tip Sensor for Precision Temperature Sensing; Leos 2009 22nd Annual Meeting of the IEEE Lasers and Electro-Optics Society; Oct. 4-8, 2009; pp. 761-762; Belek-Antala, Turkey.

Jung, I. et al.; Monolithic Silicon Photonic Crystal Slab Fiber Tip Sensor; 2009 IEEE/Leos International Conference on Optical Memos and Nanophotonics. Opt Memos 2009; Aug. 17-20, 2009; pp. 19-20; Clearwater, FL.

Third Office Action for Chinese Application No. 201080048010.2, May 25, 2015, 25 pages.

Canada Office Action for related application 2,772,453 dated Sep. 9, 2015; 4 pp.

JPO Office Action for related application 2014-192655 dated Sep. 1, 2015; 4 pp.

Fifth Office Action for Chinese Application No. 201080048010.2, Apr. 20, 2016, 10 pages.

JPO Office Action for related application 2014-192655 dated May 17, 2016; 3 pp.

\* cited by examiner

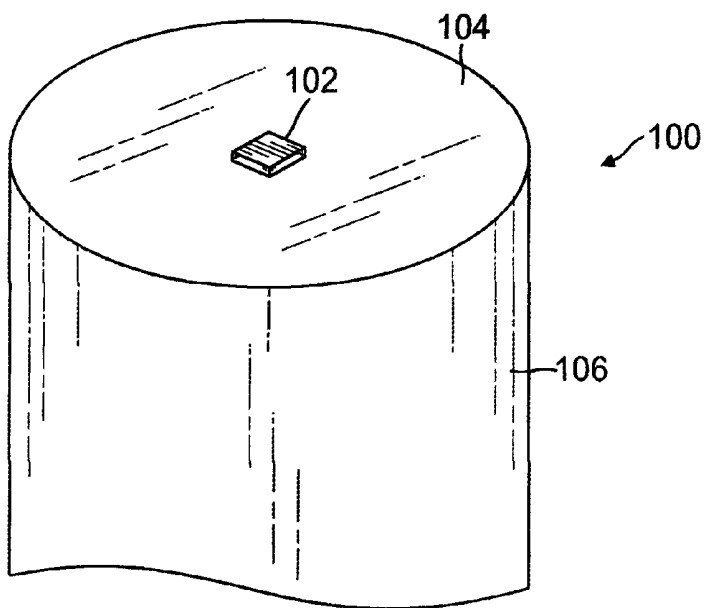

FIG. 1

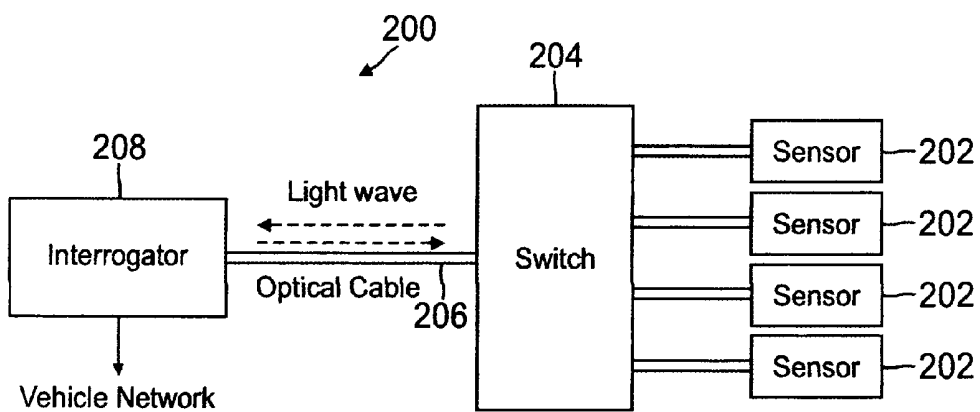

FIG. 2

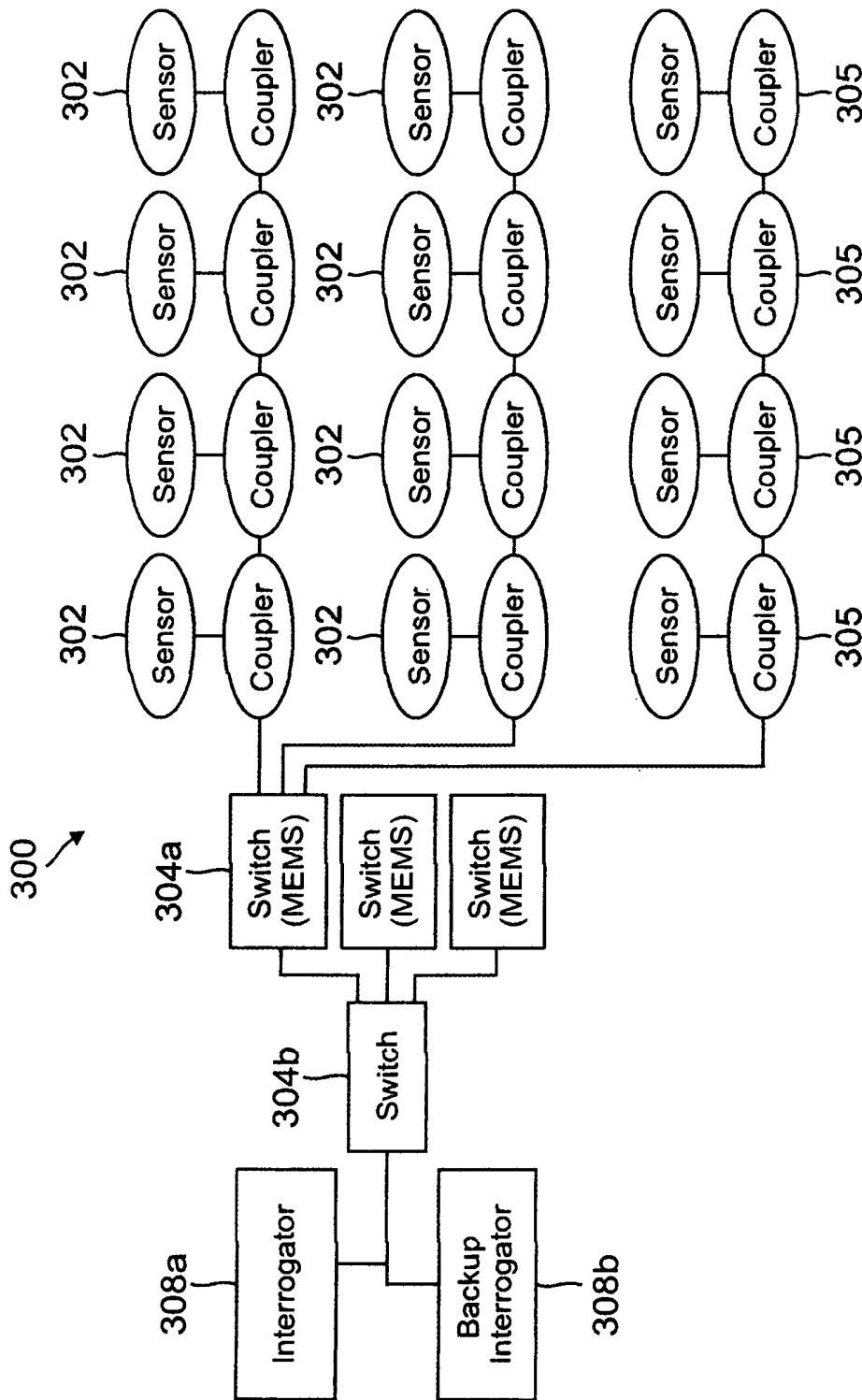

FIG. 3

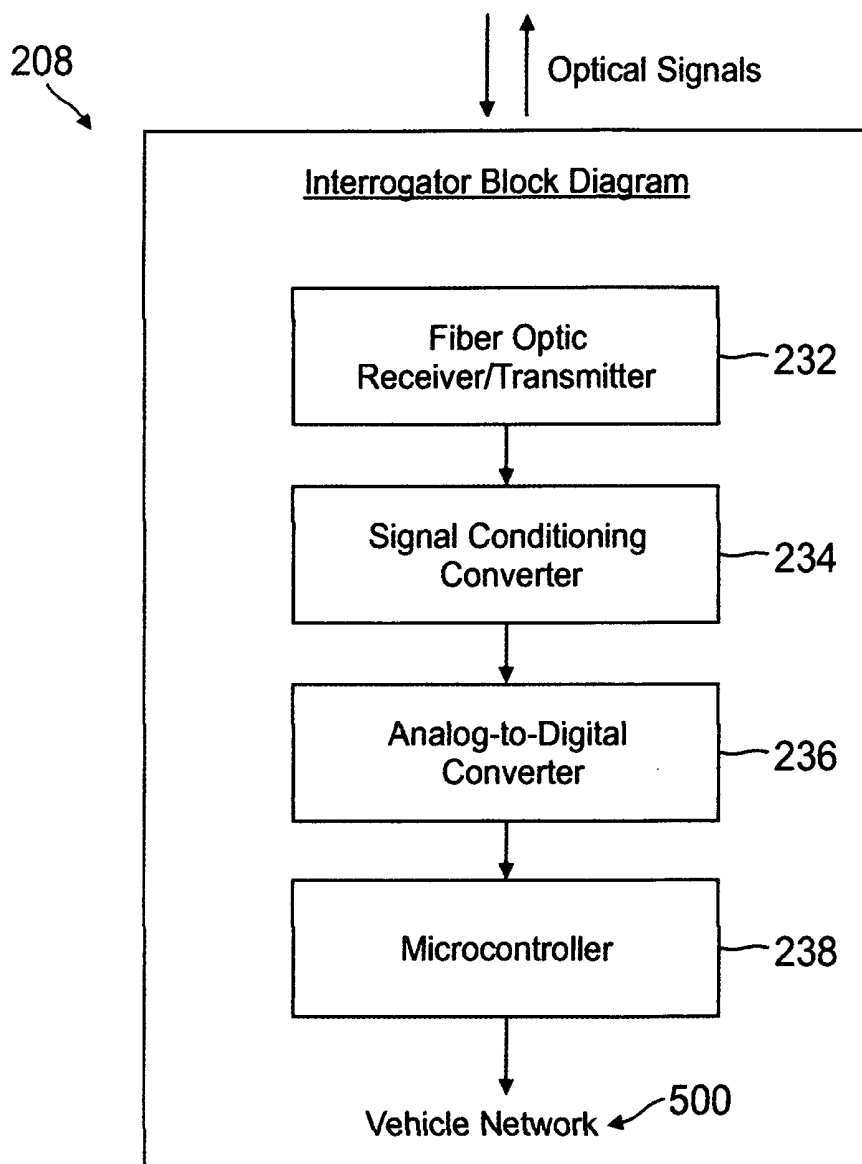

FIG. 4

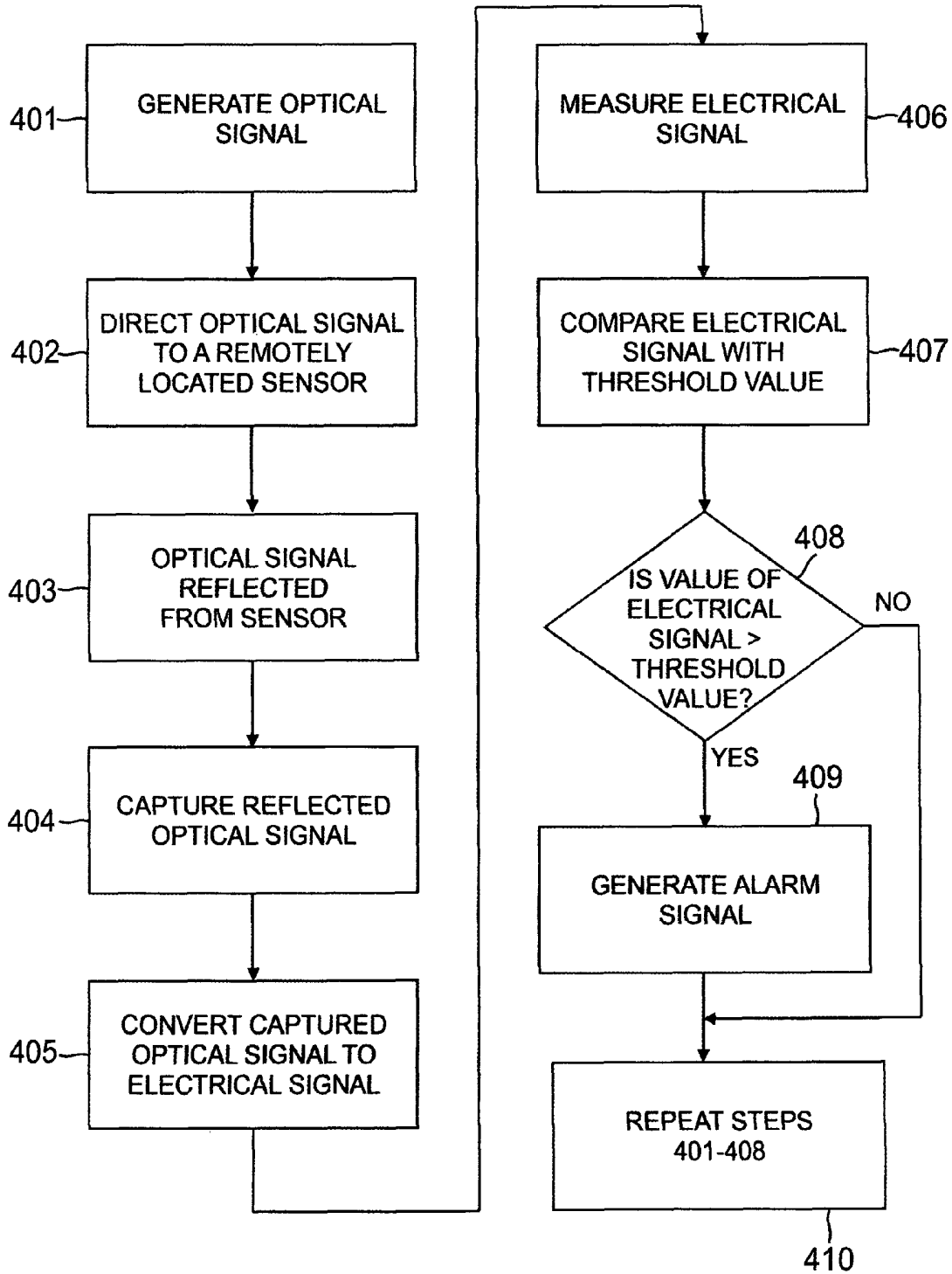

FIG. 5

## OPTICAL SENSOR INTERROGATION SYSTEM

### FIELD OF THE DISCLOSURE

The present disclosure relates generally to the field of fiber optic structural health monitors and, more particularly, to an optical sensor interrogation system, including one or more photonic crystal-based sensors for detecting changes in the properties of the materials or systems being monitored, an optical interrogator module that converts optical signals to electrical signals for use in analyzing the status of the sensors, and to a method of using the interrogation system, and even more particularly to a miniaturized optical sensor interrogation system that is light-weight and simple in construction.

### BACKGROUND OF THE DISCLOSURE

Aerospace vehicles and systems are typically equipped with instruments that monitor the health of various systems by acquiring, exchanging and analyzing data, and the communication networks in such arrangements must be robust enough to withstand repetitive and potentially destructive forces and conditions, while transmitting and processing the data collected.

In recent years, there has been a trend to use optical apparatus in lieu of electrical or mechanical devices for the purpose of monitoring the health of such systems. Optical interrogation systems are integral components in health monitoring systems used in chemical, biological, temperature and pressure sensing environments. Optical sensing techniques are highly desirable for aerospace applications due to the lighter weight and EMI continuity, but to date such sensor systems have proven too costly or complicated to deploy.

Various solutions have been proposed and tried, including Fiber Bragg Grating (FBG) type sensor systems, fiber optic path sensing, piezoelectric transducers, comparative vacuum monitors, strain gauge based systems, ultrasonic systems, and visual indicators, but each has challenges.

Currently, while Fiber Bragg Grating devices are preferred in many fields of Structural Health Monitoring, such devices require careful modification of fiber optic cable to operate as well as complicated methods for determining wavelength shifts and other phenomena. Such systems also appear to be affected by temperature changes, requiring additional equipment to compensate.

Fiber optic path sensing is extremely attractive due to its simplicity (e.g., a loop of fiber), but the resulting system can become quite complex as monitoring for breakage or changes will typically require additional equipment such as Time Domain Reflectance equipment.

Piezoelectric devices tend to be quite expensive, due to the nature of the materials used in their construction. Such devices will also typically have features of other electrical based systems (susceptibility to EMI/Lightning) as well as the need for dual wire connections for each individual sensor. Further, such devices tend to be sensitive to certain frequencies, and may require a considerable amount of baseline data measurements in order to operate properly.

Comparative Vacuum Monitoring (CVM) makes use of very fine pressure cells and looks for pressure variations which signify cracks; this appears to make for a simple and affordable sensor design. However, CVM appears to require

tubing and pressure systems in order to operate, and known CVM equipment appears to require the use of handheld systems in order to be used.

Strain Gauges are an older technology that looks at resistance changes. The sensors are quite simple, being in most cases just copper traces on a flexible substrate. Installing and reading such sensors accurately can be difficult however, and also has issues similar to the piezoelectric designs mentioned above.

Ultrasonic inspection is a technique currently being used, and requires installation of a field device run across structures and equipment in order to operate properly. Attempting to scale down such a system to an embedded type design would most likely result in a system very similar to a piezoelectric type system.

Visual inspection is the standard sensing method used at this time, and involves highly trained individuals inspecting and attempting to gauge failures of material, and estimating how long structures can last in service.

U.S. Pat. No. 6,691,007, issued to Haugse et al. on Feb. 10, 2004 and assigned to the assignee of the present disclosure, describes a system and method for monitoring conditions of a vehicle and generating a maintenance plan according to the monitored conditions. The patent discloses the use of conventional optical sensors, such as Fabry-Perot interferometric, long-period grating, and fiber Bragg grating sensors, none of which are small enough to permit miniaturization or diminished cost of the interrogator system.

A light-weight, miniaturized, and efficient optical interrogation apparatus is therefore needed to survey data from one or more optical sensors for the purpose of monitoring and reporting on the structural health of vehicle structures and systems.

### SUMMARY OF THE DISCLOSURE

In one embodiment of the disclosure, an optical sensor includes a finite length of optical fiber having a free end, and a photonic crystal mounted to the free end of the optical fiber. The optical fiber free end includes a surface that is polished, and the crystal is secured to the polished surface. The photonic crystal is coated with a material that protects the crystal from destructive environmental influences. The reflectance properties of the optical sensor can be altered by applying a range of voltages to the crystal.

In another embodiment of the disclosure, an optical interrogation system for collecting information from at least one optical sensor in a structure includes an optical signal generator for communicating with the at least one optical sensor, and optical signal receiving apparatus for collecting optical signals returned by the at least one optical sensor, where each optical sensor comprises a fiber optic strand and a photonic crystal wafer mounted on the fiber optic strand. The fiber optic strand is provided with a polished end face, and the photonic crystal wafer is secured onto the polished end face of the fiber optic strand. The photonic crystal wafer detects changes in the reflectivity spectrum of a range of wavelengths. The optical interrogation system further includes switching mechanisms arranged between the optical signal generator and the optical signal receiving apparatus, whereby two or more optical signals can be transmitted or received at the same time. The switching mechanisms may include wavelength division multiplex switches or MEMS switches. The optical signal generator may be a laser or an LED. The optical fiber may take the form of a side-scattering light guide, and include a length of photonic crystal material carried on the end of the optical fiber that is

monitored by the optical fiber. The optical interrogation system may further include a voltage altering apparatus coupled with the photonic crystal to control the reflectance properties of the crystal. The optical sensor may detect at least one of pressure, temperature, chemical materials or biological materials.

In still another embodiment of the disclosure, a method for monitoring the structural health of a vehicle includes the steps of generating an optical signal, directing the optical signal at an optical sensor located remotely from the optical signal generator, the optical sensor including a photonic crystal wafer optically interacting with the optical signal and an environmental condition, capturing a reflected optical signal returned from the optical sensor, and analyzing the reflected optical signal to determine a change in the environmental condition. The method further includes the step of sending an alarm signal to a control apparatus when the analyzed reflected optical signal indicates an unacceptable change in the environmental condition of the vehicle structure. The method further includes a step of first converting the optical signal to an electrical signal before analyzing the signal.

Further aspects of the apparatus and the method of using the apparatus are disclosed herein. The features as discussed above, as well as other features and advantages of the present disclosure will be appreciated and understood by those skilled in the art from the following detailed description and drawings.

#### BRIEF DESCRIPTION OF THE DRAWINGS

FIG. 1 is a perspective view of an optical sensor according to the present disclosure;

FIG. 2 is a schematic diagram that shows the structure of the optical interrogation system according to the present disclosure;

FIG. 3 is a schematic diagram showing a failure tolerant optical switching system according to the present disclosure;

FIG. 4 is a block diagram of the optical interrogator according to the present disclosures, and

FIG. 5 is a block diagram illustrating steps of a method of monitoring conditions of a vehicle using an optical sensor, as has been described herein.

#### DETAILED DESCRIPTION OF THE DISCLOSURE

Embodiments of the present invention now will be described more fully hereinafter with reference to the accompanying drawing. However, many different embodiments are contemplated and the present disclosure should not be construed as limited to the embodiments set forth herein; rather, these embodiments are provided so that this disclosure will be thorough and complete and better convey the scope of the disclosure to those skilled in the art.

In its broadest sense, this disclosure presents a system for monitoring conditions in a vehicle and providing data representative of such conditions to a health management system residing in the vehicle. The system includes one or more optical sensors, and an optical interrogation apparatus located within the vehicle. The optical interrogation apparatus converts optical signals into electrical signals that can be used by the vehicle integrated health management system to monitor the status of the systems of the vehicle.

This disclosure further presents a structural health monitoring system that includes one or more optical sensors, an optical interrogation apparatus, and optically responsive

infrastructure located between the sensor(s) and the interrogation apparatus. The health monitoring system is able to withstand extreme environments, and can be applied to chemical sensing, biological sensing, and temperature or pressure sensing.

Referring to FIG. 1, an optical sensor 100 includes a photonic crystal 102 mounted on, and secured to, the end face 104 of a single mode optical fiber 106. The photonic crystal, in its simplest form, is made from a single layer of semiconductor material, but can include several layers of semiconductor material mounted on the end of the fiber strand 106. The sensor principle is based on detecting changes in the reflectivity spectrum of photonic crystals. The single layer photonic crystal has a sharp reflection resonance in the wavelength range that is being monitored. Preferably, the photonic crystal sensor is fabricated in a silicon foundry using standard fabrication processes, and will meet the requirements for size, interface characteristics, and robustness for operation in the harshest operating environments. Depending on the material construction, various effects can be monitored, as for example, pressure against the tip of the fiber. A more complicated buildup, for example applying a range of voltages to the photonic crystal to change reflectance properties, can allow a "smart" component to use the photonic crystal or wafer as a low powered communications device by modifying light reflectance that can be read by the optical interrogator. Another possible implementation would be to use the fiber as a side-scattering light guide, with a series of photonic crystal patches or a length of photonic crystal material monitored by a single fiber.

Photonic crystal sensors are also far less complicated to use and manufacture than the Fiber Bragg Grating sensors discussed earlier in this disclosure. Fiber Bragg Grating sensors are currently made by stripping the coating off of existing single mode fibers (from 125 micrometer glass fiber), "writing" the Bragg Grating into the fiber, and then recoating with a replacement material. Writing the grating into the fiber can be accomplished through the use of a laser and phase mask, as well as other methods. Selection of cladding replacement, writing process, and fiber composition can all have an effect on the final sensor performance. This is a complicated process to perform.

The Fiber Bragg Sensors can be highly sensitive which is a benefit, and they lend themselves to in-line construction along the length of a single fiber, capable of simultaneously reading data from 20 or more sensors. However, such devices operate by changing the wavelength of reflected light (short wavelength typically) across its length. This drives a lot of the complexity of the system into the interrogation equipment of the sensors, as it must be capable of reading extremely small changes (interference effects of all the fringe) in wavelength at very low amplitudes of reflected light. This, it appears, is a direct result of a great deal of variability introduced during fabrication which can complicate construction.

Additionally, Fiber Bragg Grating sensor operation requires a change along its length (e.g., stretching, bending, pressure, etc.). In some cases this is advantageous, but in most others, where a single point of interest needs to be monitored, it can be a liability. This also tends to make the sensors naturally sensitive to temperature changes (due to the flexing or stretching of the fiber sections) which must be compensated for.

In contrast, photonic crystals offer mass manufacturing capability, repeatability, and a highly controlled sensing area. These devices also act more as a pure reflector, with a greater return of incident light. Crystal lattices are fabricated

using existing semiconductor techniques. These devices can then be cut out of wafers in much the same way as integrated circuits are. For a basic installation, a fiber end is polished using existing telecomm type equipment, and a lattice wafer is adhered to its surface. This element may be left bare, or it can be coated with a material that protects the crystal from destructive environmental conditions, depending on the intended application. The use of photonic crystals significantly reduces the weight and complexity of the components that make up the interrogator system of the present disclosure, thereby permitting miniaturization of the system.

Referring to FIG. 2, the optical interrogation system 200 of the present disclosure is seen to include a plurality of optical sensors 202, an optical switch 204, optical cables 206, and an optical interrogator 208. Each sensor 202 comprises the fiber-plus-photonic-crystal (FPPC) structure 100 described above.

The optical switch 204 may be an integrated, all-solid-state device that is small, lightweight, and capable of withstanding a wide range of vibrations. This device, which may include one or more microelectromechanical system switches (MEMS), is reliable in harsh environments, is failure tolerant, and is easily serviceable. The optical network shown in FIG. 2 integrates fast-tunable semiconductor lasers with optical passive wavelength routers, such as waveguide routers. The lasers enable the use of high capacity, low power consumption optical packet switches and a light weight interrogator.

The optical interrogator 208, which converts optical signals to electrical signals that are used by the vehicle health management system to monitor the status of the system sensors located at remote locations in the vehicle, is similar to but replaces the conventionally used Fiber Bragg Grating sensor systems.

FIG. 3 depicts another system 300 according to the present disclosure emphasizing a redundant architecture that offers failure tolerance to the vehicle network. A plurality of optical sensors 302 of the type shown in FIG. 1 are each connected to a MEMS switch 304a through a coupler 305. The MEMS switches 304a provide connections to a back-up switch 304b, so that the on-board optical network can operate with minimum delay in the case of failure of the fiber-optic cables or the wave guide grating routers. The MEMS switches 304a are small, wavelength-insensitive, and optically transparent, and thus are simple to install and operate. Further, their switching time is on the order of tens of microseconds, which is sufficiently fast for recovery of most functions given the proper redundancy management implementation. The system further includes a primary interrogator 308a and a backup interrogator 308b.

FIG. 4 is a block diagram illustrating the components that make up the optical interrogator 208 of the present disclosure. Interrogator 208, which provides an interface between the optical sensors and the control and data acquisition systems of the vehicle network 500, includes a fiber optic receiver/transmitter 232, a signal conditioning converter 234, an analog to digital converter 236, and a microcontroller 238. The fiber optic receiver 232 converts the light intensity from an optical fiber into an electrical signal, which is amplified and passed to a filter circuit that conditions the signal for input to the analog-to-digital converter 236. From there, the digitized signal is sent for analysis to the microcontroller 238, the latter monitoring the signal to determine if it falls below a specified threshold. If such is determined, the microcontroller sends a warning signal to the vehicle network 500.

FIG. 5 is a block diagram showing steps of a method for monitoring the structural health of a vehicle according to the present disclosure. In block 401, a first step entails generating an optical signal, as for example, by a laser or LED. Next, as shown in block 402, the optical signal is directed at a remotely located optical sensor in the vehicle. The sensor includes a fiber optic cable with a photonic crystal mounted to an end surface of the cable, as described above in connection with FIG. 1. In block 403, the optical signal is reflected from the sensor, and is returned and captured by optical signal receiving apparatus, as shown in block 404. In the step represented by block 405, the optical signal is converted to an electrical signal, and any signal conditioning, such as filtering and/or amplifying the signal is then carried out. In the step represented by block 406, the attributes of interest of the electrical signal is measured. Attributes of the signal which might be of interest include its amplitude, its frequency, its wavelength, etc. In the step shown in block 407, the measured attribute(s) of the electrical signal is/are compared to a pre-selected threshold value, which may represent an acceptable upper limit value of the measured attribute. Next, as shown in block 408, the method executes a decision as to whether the value of the electrical signal attribute exceeds the respective threshold values. If the value of the electrical signal attribute exceeds the threshold value, an alarm signal is generated (at block 409) and the method proceeds to block 410 where the steps of blocks 401-408 may be repeated in accordance with the requirements of the monitoring process schedule. On the other hand, if the value of the electrical signal attribute does not exceed the threshold value, then the method proceeds directly to block 410 where steps 401-408 are repeated according to the monitoring process schedule. It is to be understood that the monitoring process schedule might call for a single interrogation of the optical sensors at user predetermined intervals, continuous interrogation, repeated sets of interrogation at user selected intervals, or any combination of interrogations and intervals. Any of the attributes of the electrical signal that may be of interest may be measured and evaluated, and compared against a corresponding threshold value, preferably determined and established before installation in the vehicle.

An optical interrogation system according to the present disclosure is light-weight and miniaturized, and can withstand extreme environments. The system can be applied to chemical sensing, bio sensing, and temperature, pressure sensing. Also, it can be embedded in an aircraft fuselage and where health monitoring is desired. The sensor interrogation system of this disclosure penetrates into the most demanding environments, e.g. engines and weight-bearing structures; their packaging and electronic integration are designed to tolerate extremes of temperature, mechanical vibration, corrosive materials and electromagnetic interference, while retaining a small overall volume and non-intrusive operation so as to not adversely affect operation of the systems that are monitored.

The apparatus of this disclosure will allow for the addition of switch type devices in order to increase the reuse of the interrogator hardware. Current state of the art Fiber Bragg Grate Sensor systems appear to focus on the use of splitters and couplers almost exclusively. While this arrangement can provide extremely fast access to sensor data, as the system is essentially connected to everything at once, it appears to complicate the interrogation device design as all of the simultaneous reflections must be "decoded" at once. The Fiber Bragg Grate sensors also appear to only be capable of

light modification in a very narrow spectral band, which requires additional sensitivity in the interrogator.

The photonic crystal approach permits switching devices to operate in the micro-, to milli-, second range dependent on size. In cases such as structural health monitoring, an aircraft may in fact not need to have its sensing network activated except in certain conditions where the system must be polled every few seconds, minutes, or even hours. Taking advantage of this, it should be possible to reduce the complexity, cost and size of the interrogator system while also increasing redundancy that may be built into the system.

For the illumination source, laser and tunable laser systems currently appear to be the best interrogation apparatus. CCD type equipment may be used as the sensing devices; however, filtered light sensors in arrays may also be used. While this apparatus is already used for the Fiber Bragg Grate Sensors, the use of photonic crystal based materials makes design of the system far easier, and could enable the use of lower quality light sources, such as LEDs, which may also be of use in this sensor system as more light energy will be reflected and there is less need to worry about delicate wavelength shifts.

Additionally, this sensing approach may lend itself to even lower cost sensing solutions. For example, it may in fact be possible to make use of this approach with much cheaper plastic fiber cable, standard light emitting diodes for light sources, and cheaper light sensors. In this way the same sensing system can be adapted for low cost use in areas such as panel switching, simple proximity sensing (doors), and low quality pressure type applications (occupancy weight sensing systems such as are used in automobiles) and other applications where a low weight, low cost, and yet EMI immune system would be of benefit. Such scalability between low reliability-need systems and high reliability systems appears attractive from a research standpoint.

While the disclosure has been made with reference to a preferred embodiment, it will be understood by those skilled in the art that various changes may be made and equivalents may be substituted for elements thereof without departing from the scope of this disclosure.

The invention claimed is:

**1.** An optical interrogation system comprising:

an optical signal generator configured to transmit a first signal;

an optical sensor oriented to receive the first signal and transmit at least one optical signal associated with the first signal, the optical sensor comprising a fiber optic strand and a photonic crystal wafer attached directly against a terminating end surface of a core of the fiber optic strand;

optical signal receiving apparatus for collecting the at least one optical signal transmitted by the at least one optical sensor and converting the at least one optical signal to an electrical signal; and

switching mechanisms arranged between the optical signal generator and the optical signal receiving apparatus, such that two or more optical signals may be transmitted or received at the same time.

**2.** The optical interrogation system of claim 1, wherein the end portion comprises a polished end face.

**3.** The optical interrogation system of claim 2, wherein the photonic crystal wafer detects changes in the reflectivity spectrum of a range of wavelengths.

**4.** The optical interrogation system of claim 1, wherein the switching mechanisms comprise wavelength division multiplex switches.

**5.** The optical interrogation system of claim 1, wherein the optical signal generator comprises a laser.

**6.** The optical interrogation system of claim 1, wherein the optical signal generator comprises an LED.

**7.** The optical interrogation system of claim 1, and further including voltage altering apparatus coupled with the photonic crystal to control the reflectance properties of the crystal.

**8.** The optical interrogation system of claim 1, wherein the optical sensor detects at least one of pressure, temperature, chemical materials and biological materials.

**9.** An optical interrogation system comprising:

an optical signal generator configured to transmit a first signal;

an optical sensor oriented to receive the first signal and transmit at least one optical signal associated with the first signal, the optical sensor comprising a fiber optic strand and a photonic crystal wafer attached directly against a terminating end surface of a core of the fiber optic strand;

optical signal receiving apparatus for collecting the at least one optical signal transmitted by the at least one optical sensor and converting the at least one optical signal to an electrical signal; and

MEMS switches arranged between the optical signal generator and the optical signal receiving apparatus, such that two or more optical signals may be transmitted or received at the same time.

**10.** An optical interrogation system comprising:

an optical signal generator configured to transmit a first signal;

an optical sensor oriented to receive the first signal and transmit at least one optical signal associated with the first signal, the optical sensor comprising a fiber optic strand, a side-scattering light guide, and a length of photonic crystal material carried on an end of the fiber optic strand is monitored by the fiber optic strand; and

optical signal receiving apparatus for collecting the at least one optical signal transmitted by the at least one optical sensor and converting the at least one optical signal to an electrical signal.

\* \* \* \* \*

专利名称(译)	光学传感器询问系统		
公开(公告)号	<a href="#">US9482927</a>	公开(公告)日	2016-11-01
申请号	US12/589668	申请日	2009-10-26
[标]申请(专利权)人(译)	波音公司		
申请(专利权)人(译)	波音公司		
当前申请(专利权)人(译)	波音公司,		
[标]发明人	CARRALERO MICHAEL LARSEN TY A		
发明人	CARRALERO, MICHAEL LARSEN, TY A.		
IPC分类号	G02B6/12 A61B5/00 G02B6/42 G02B6/26 G01D5/26 G01N21/55 G02F1/295 G02B6/122 G01N21/47 G01B9/02		
CPC分类号	G02F1/295 A61B5/0066 G01D5/268 G01N21/55 A61B5/0059 G01B9/02091 G01B2290/45 G01N21 /4795 G01N2201/068 G01N2201/088 G02B6/1225		
其他公开文献	US20110097031A1		
外部链接	<a href="#">Espacenet</a> <a href="#">USPTO</a>		

摘要(译)

用于监测车辆结构的各种状况的装置和方法，包括光学传感器，包括安装在一端的承载光子晶体的光纤，包括光学信号发生器的询问系统，所述光学信号发生器与远离所述光学传感器的一个或多个光学传感器询问模块以及使用询问系统监测车辆结构健康的方法。

